

01D TO VPN1006SDFW-V1

DIP TREATED OVERLAP PENT 10X6 SINGLE DOOR FIXED WINDOW

BEFORE YOU START PLEASE READ INSTRUCTIONS CAREFULLY

- Check the pack and make sure you have all the parts listed.
- When you are ready to start, make sure you have the right tools at hand (not supplied) including a Phillips screwdriver, Stanley knife, Wood saw, Step ladder, Hammer and a Drill with 2mm bit.
- Ensure there is plenty of space and a clean dry area for assembly.

LOCATION FOR YOUR GARDEN BUILDING

A minimum of 60cm should be left around the perimeter of your garden building to allow access for maintenance, annual treatment and to allow air flow around the building.

Where possible you should avoid placing your garden building underneath large trees to prevent the tree causing damage to the building.

TIMBER

As with all natural materials, timber can be affected during various weather conditions. For the duration of heavy or extended periods of rain, swelling of the wood panels may occur. Warping of the wood may also occur during excessive dry spells due to an interior moisture loss. Unfortunately, these processes cannot be avoided but can be helped. It is suggested that the outdoor building is sprayed with water during extended periods of warm sunshine and sheltered as much as possible during rain or snow.

Once your garden building has been installed it will need to be treated as soon as possible and annually to prevent the timber from deteriorating and to waterproof it. This is required to maintain the anti-rot guarantee.

Dip Treated buildings - Require a preservative treatment to protect against rot and decay and a waterproof treatment to prevent water ingress

Pressure Treated buildings - Require a waterproof treatment to prevent water ingress

Log Cabins - Are supplied untreated and require a preservative and waterproofing treatment.

BUILDING A BASE

When thinking about where the building and base is going to be constructed: Ensure that there will be access to all sides for maintenance work and annual treatment.

Ensure the base is level and is built on firm ground, to prevent distortion. Refer to diagrams for the base dimensions, The base should be slightly smaller than the external measurement of the building, i.e. The cladding should overlap the base, creating a run off for water. It is also recommended that the floor be at least 25mm above the surrounding ground level to avoid flooding.

TYPES OF BASE

- Concrete 75mm laid on top of 75mm hard-core.
- Slabs laid on 50mm of sharp sand.

Whilst all products manufactured are made to the highest standards of Safety and in the case of childrens products independently tested to EN71 level, we cannot accept responsibility for your safety whilst erecting or using this product.



x2 All buildings should be erected by two adults



Winter = High Moisture = Expansion
Summer = Low Moisture = Contraction



2mm Drill bit

For ease of assembly, you **MUST** pilot drill all screw holes and ensure all screw heads are countersunk.



CAUTION

Every effort has been made during the manufacturing process to eliminate the prospect of splinters on rough surfaces of the timber. You are strongly advised to wear gloves when working with or handling rough sawn timber.



For ease of assembly, you will need a tape measure to check dimensions of components.

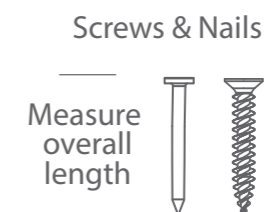

Measure overall length

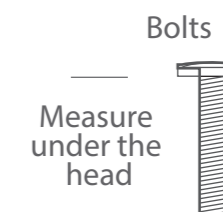

Measure under the head

Bolts

To identify the fixings required for each step use a measuring tape.

****Protim Aquatan T5 (621)****

Your building has been dip treated with **Aquatan**.

Aquatan is a water-based concentrate which is diluted with water, the building has been treated by the correct application of Aquatan solution and then allowed to dry.

Aquatan is a decorative finish to colour the wood, which is applied industrially to timber fence panels and garden buildings.

Aquatan undiluted contains: boric acid, sodium hydroxide 32% solution, aqueous mixture of sodium dioctyl sulphosuccinat and alcohols: 2, 4, 6-trichlorophenol.



REGISTER FOR YOUR
ANTI-ROT
GUARANTEE TODAY

PLEASE SCAN HERE:



For assistance please contact customer care on: 01636 821215

Mercia Garden Products Limited,
Sutton On Trent,
Newark,
Nottinghamshire,
NG23 6QN

www.merciagardenproducts.co.uk



01D TOVPN1006SDFW-V1

Please retain product label and instructions for future reference

Overall Dimensions:

Width = 2974mm
Depth = 1891mm
Height = 2007mm

Base Dimensions:

Width = 2912mm
Depth = 1753mm

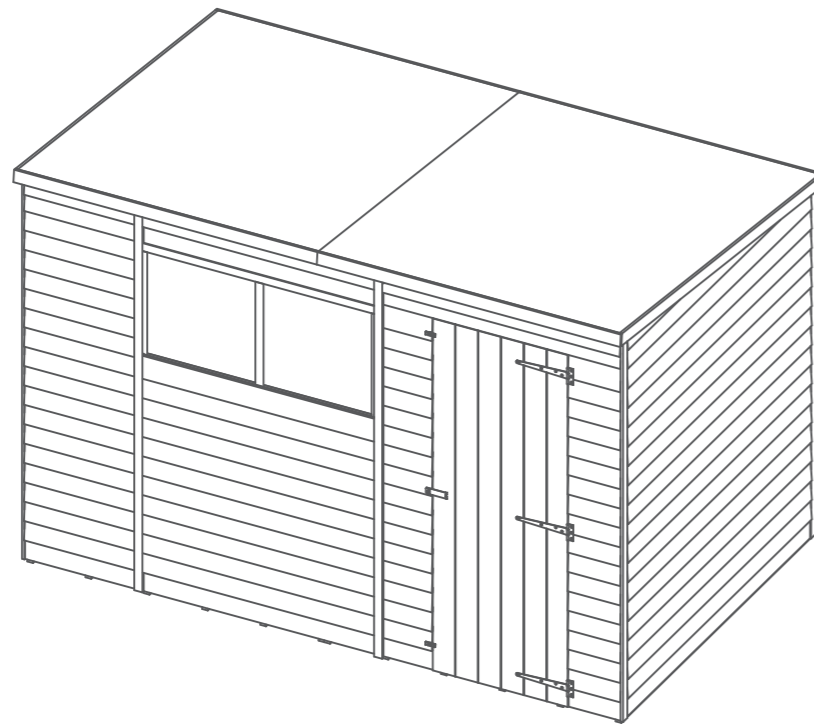

1

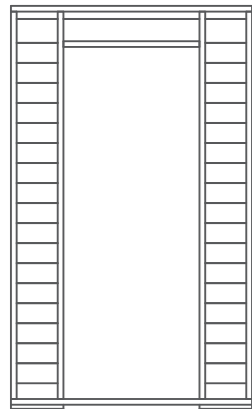

Door Panel QTY 1
AI-01R11OVSD1180X1972-V1

2

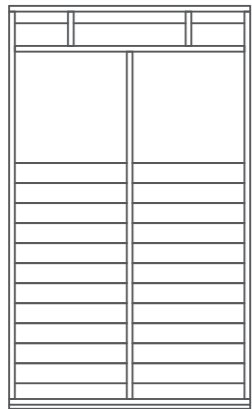

Window Panel QTY 1
AI-01R11OV2CW1180X1972-V1

3

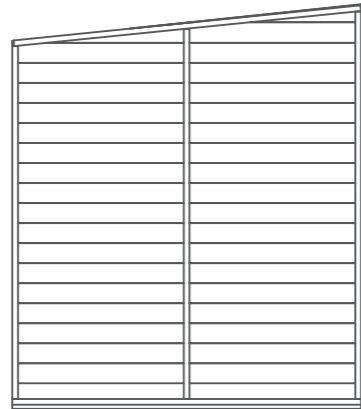

Right Gable QTY 1
AI-01R11OVLPG1707X1980-V1

4

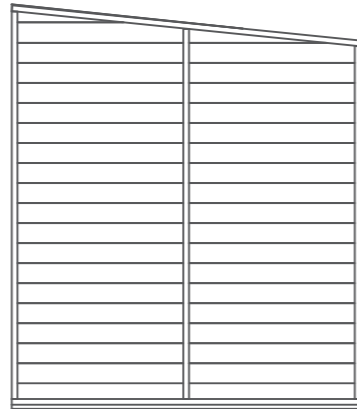

Left Gable QTY 1
AI-01R11OVLPL1707X1980-V1

5



Plain Panel 1
562x1799mm QTY 1
AI-R11OVPP562X1799-V1

6

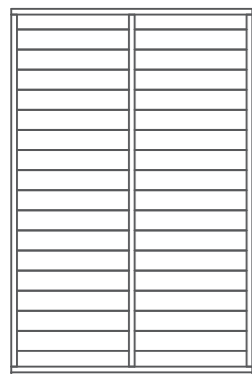

Plain Panel 2
1180x1799mm QTY 2
AI-R11OVPP1180X1799-V1

7

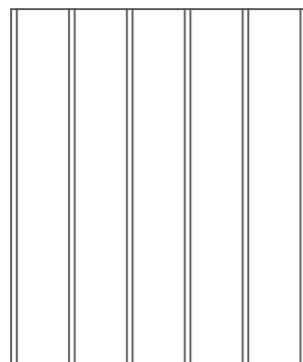

Floor QTY 2
AI-R11OSBF1753X1456-V1

8



Roof QTY 2
PI-03-0258 TEMP

9

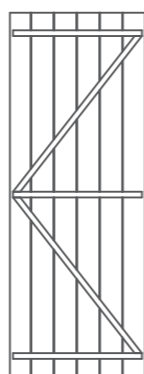

Door QTY 1
AI-R11FBMBZBD661X1780-V1

10



Plain Panel 3
562x1972mm QTY 1
AI-R11OVPP562X1972-V1

11



Ridge Bar 27x44x1712mm QTY 3
F2744-1712mm

12



Door Block 28x28x150mm QTY 1
F2828-150mm

13

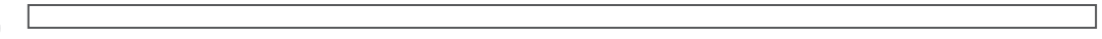

Eaves Framing 28x28x1475mm QTY 4
F2828-1475mm

14



Window Strips 12x28x580mm QTY 4
S1228-580mm

15



Window Cover Trims 12x40x518mm QTY 3
S1240-518mm

16



Window Cover Trim 12x40x1180mm QTY 1
S1240-1180mm

17



Back Cover Trims 12x40x1798mm QTY 4
S1240-1798mm

18



Front Cover Trims 12x40x1970mm QTY 4
S1240-1970mm

19



Fascias 12x60x1487mm QTY 4
S1260-1487mm

20



Fascias 12x60x1870mm QTY 2
S1260-1870mm

21



Door Beading Strip 12x28x1720mm QTY 2
S1228-1720mm

22



Styrene QTY 2
PI-05-0114

23



Window Cill QTY 1
PI-08-0013

24



Turn Button QTY 2
PI-07-0034

25



Hasp and Staple QTY 1
PI-07-0207

26



Felt QTY 1
PI-01-0016

27

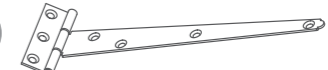

T-Hinge QTY 3
PI-07-0021

Nail Bag

There may be extra screws present in the nail bag



60mm Screw x 6



30mm Screw x 148



50mm Screw x 36



20mm Screw x 3



40mm Screw x 28



Felt Tacks x 130

Pre Assembly

Before assembling remove the transportation blocks from the bottom of each panel.

Take care removing the blocks as to not damage the panels. Tap with a flat headed screwdriver and hammer.

Dispose of the blocks once removed.

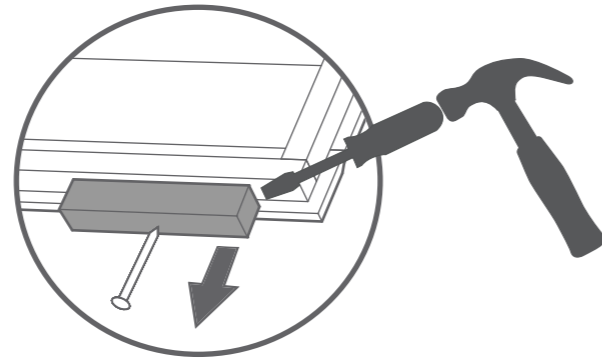

Step 2

Place the assembled floors (**No.7**) on a firm and level base, ensure the base has suitable drainage free from areas where standing water can collect. See the front page for base requirements.

IMPORTANT: Pre-drill before fixing screws.

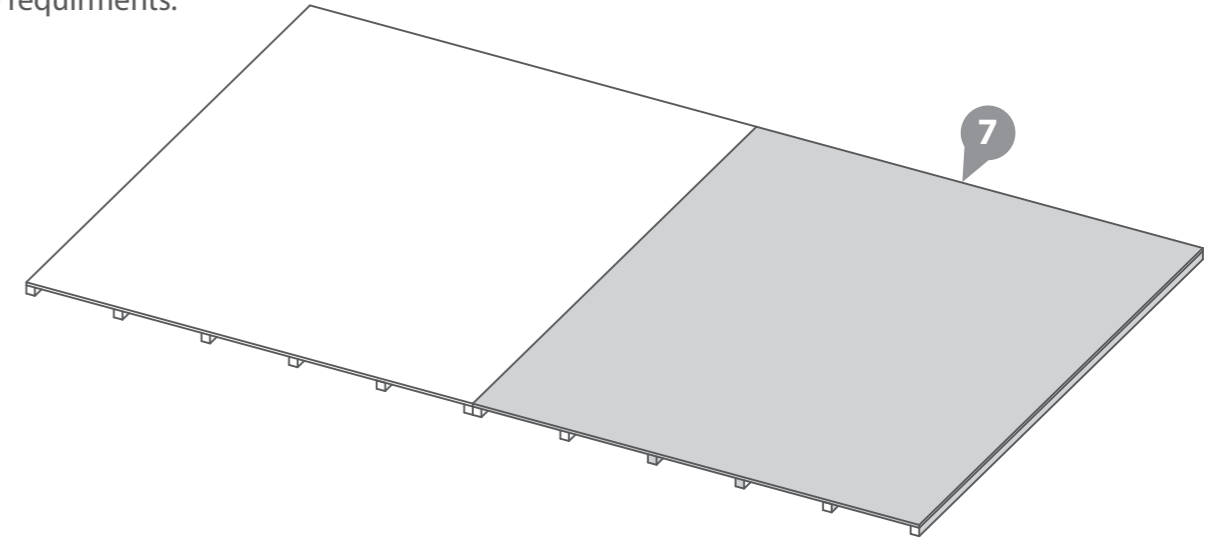

Step 1

Parts Needed - No.7 QTY 2

Secure the floors (**No.7**) together through framing to framing using 10x50mm screws

10x50mm Screws



Pre drill hole

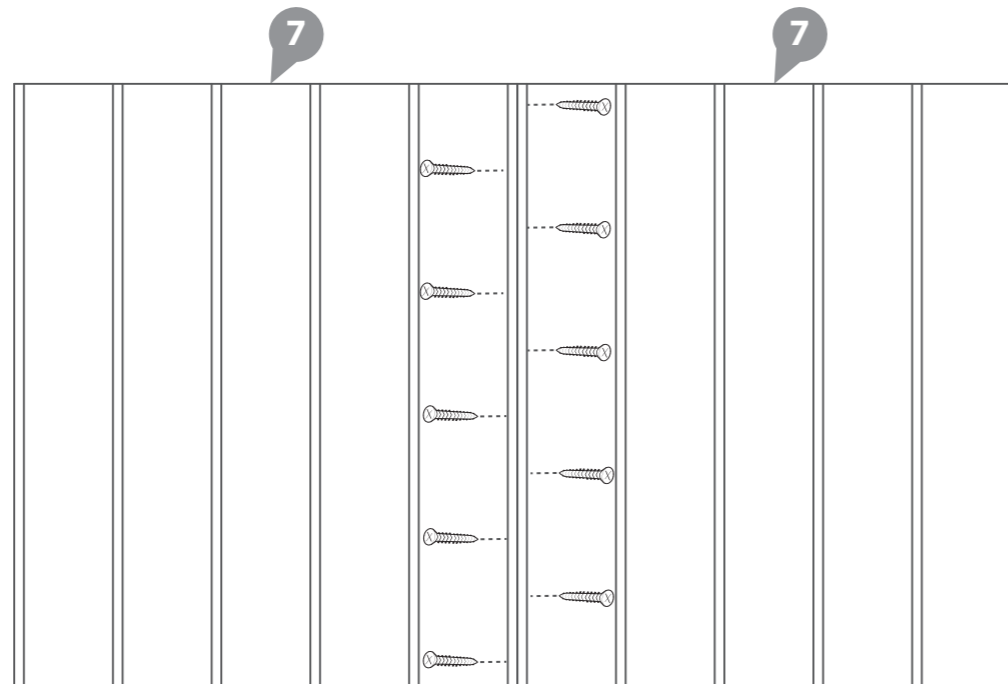

Step 3

Parts needed - No. 1 QTY 1
 No. 9 QTY 1
 No. 27 QTY 3

Place the door (No.9) within the Door Panel (No. 1). Fix the T Hinges (No. 27) onto the door and Door Panel as shown (taking into account on which side of the Door Panel opening you want the Door to open). Ensure that the screws go through the cladding and into the framing behind.

21x30mm Screws



****PLEASE NOTE**** Before fitting the hinges, ensure the door is in the correct position depending on which side you want the door to open. See external illustrations below which show the doors internal framing.

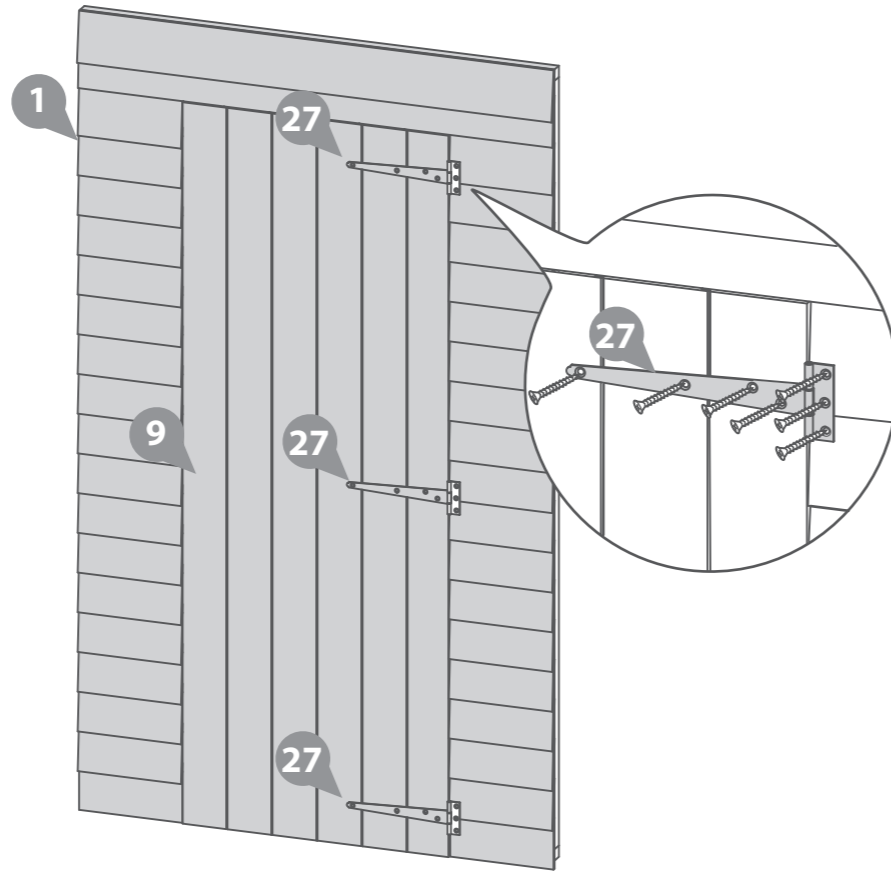

Opens from the Left

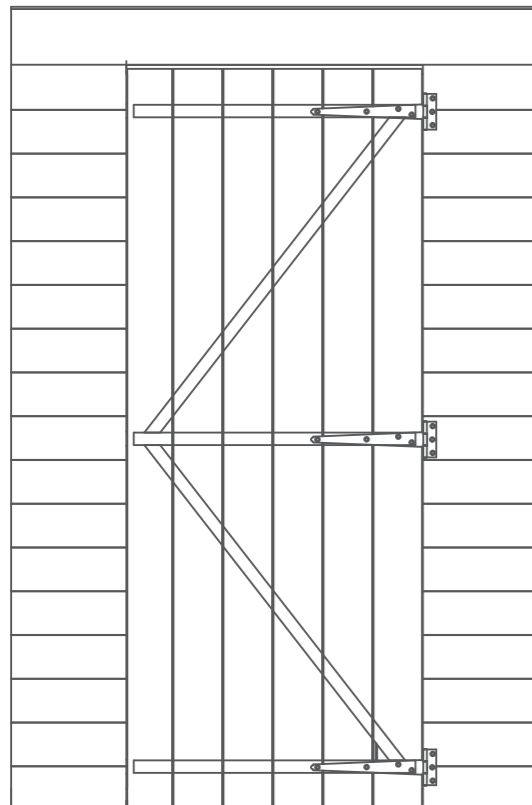

Opens from the Right

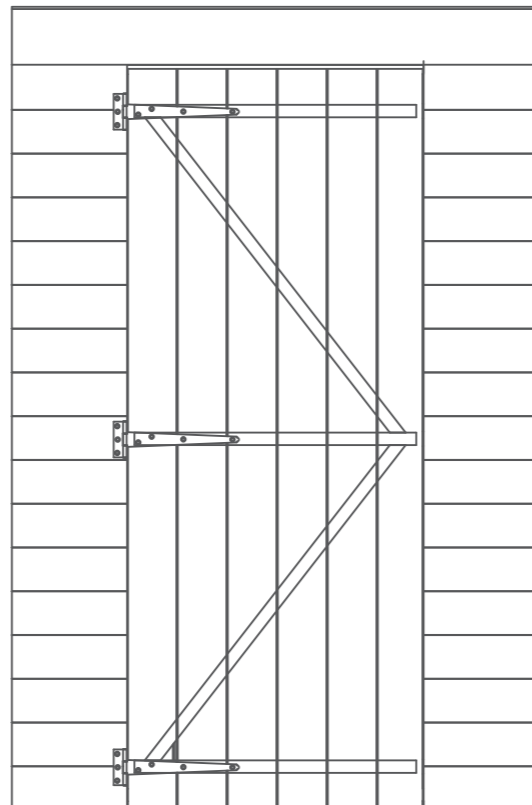

Step 4

Parts Needed - No.4 QTY 1
 - No.5 QTY 1
 - No.10 QTY 1

Place the Left Gable (No.4) and the Plain Panel 1 (No.5) onto the floor. Secure the gable to the plain panel at the corner using 3x50mm screws.

Fix the Plain Panel 3 (No.10) to the Left gable using 3x50mm screws.

Do not secure the building to the floor until the roof is fitted.

Position the panels so there is equal spacing between the floor and cladding

6x50mm Screws

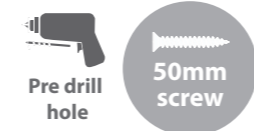

****Please note: the back panels are interchangeable and can be positioned on either side of the building. Decide which works best before assembly****

IMPORTANT: Pre-drill before fixing screws.

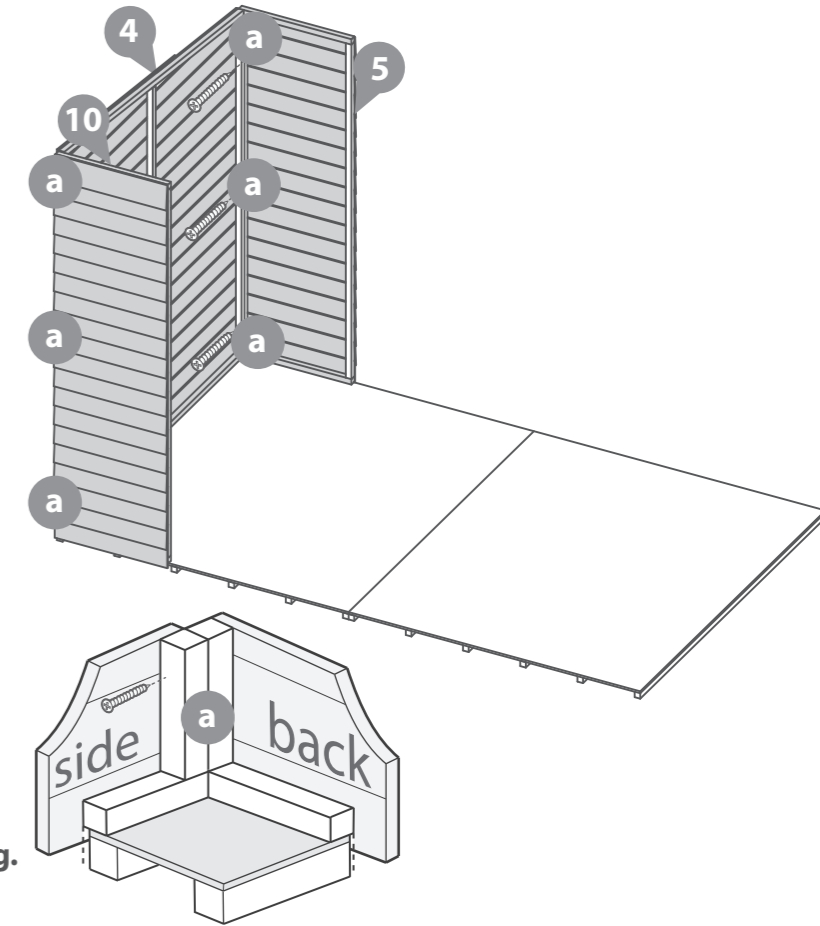

Step 5

Parts Needed - No.6 QTY 2

Fix the Plain Panel 2 (No.6) to the Plain panel 1 using 3x50mm screws in an alternating pattern, repeat for the second Plain panel 2.

Do not secure the building to the floor until the roof is fitted.

Position the panels so there is equal spacing between the floor and cladding

6x50mm Screws



****Please note: the back panels are interchangeable and can be positioned on either side of the building. Decide which works best before assembly****

IMPORTANT: Pre-drill before fixing screws.

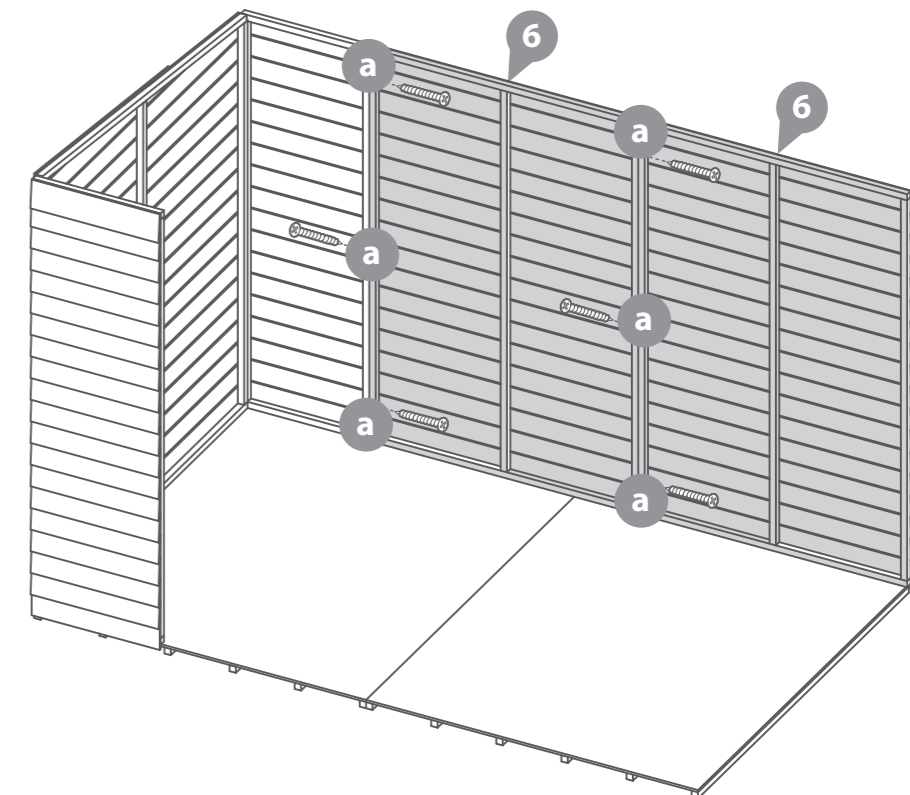

Step 6

Parts Needed - No.2 QTY 1
- No.3 QTY 1

Place the Window Panel (No.2) and the Right Gable (No.3) onto the floor, secure at the corners using 3x50mm screws per corner.

Do not secure the building to the floor until the roof is fitted.

Position the panels so there is equal spacing between the floor and cladding

6x50mm Screws



****Please note: the front panels are interchangeable and can be positioned on either side of the building. Decide which works best before assembly****

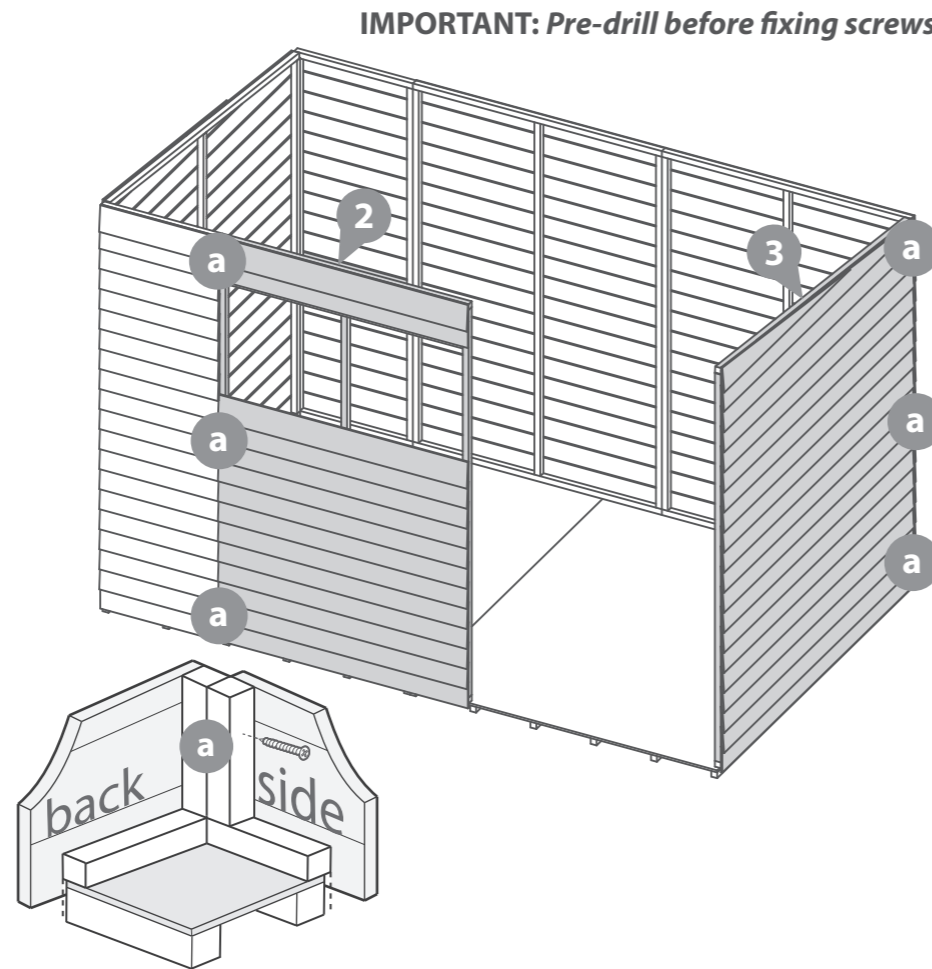

Step 8

Parts needed - No.11 QTY 3

Align the ridge bars (No.11) between the front and back of the building, align the middle ridge bar central to the building. Secure 2x60mm screws per Ridge bar, ensuring to go through the panel framing and into the ridge bar.

***Ensure the ridge bar is flush with the top framing of the gable tops.**

6x60mm Screws

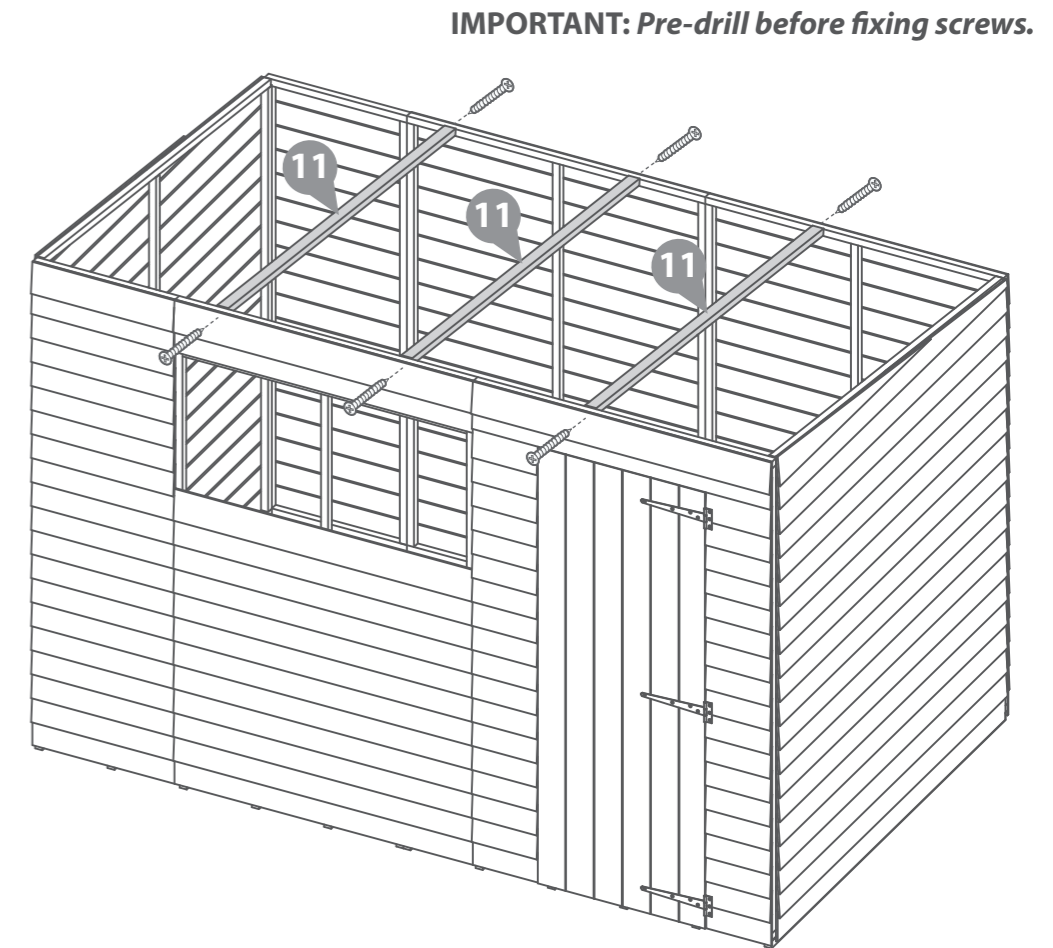

Step 7

Parts Needed - No.1 QTY 1

Place the Door panel (No.1) onto the floor and fix at the corner using 3x50mm screws. Fix the Door panel to the Window panel using 3x50mm screws in an alternating pattern.

Do not secure the building to the floor until the roof is fitted.

Position the panels so there is equal spacing between the floor and cladding

6x50mm Screws



****Please note: the front panels are interchangeable and can be positioned on either side of the building. Decide which works best before assembly****

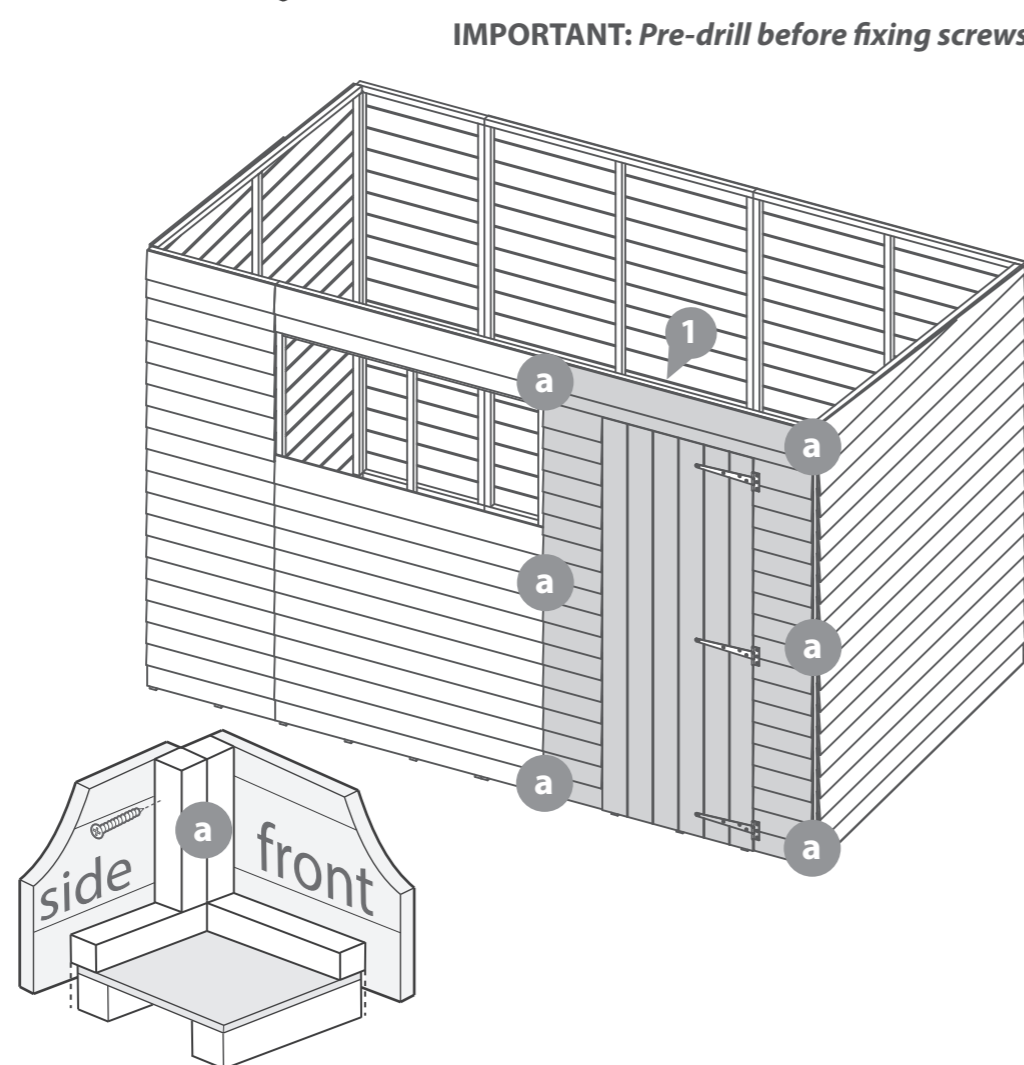

Step 9

Parts Needed - No.8 QTY 2
- No.13 QTY 4

Fix the Eaves framing (No.13) to the roof sheets (No.8) using 4x30mm screws per eaves frame. The framing should finish flush with the edge of the roof sheet

16x30mm Screws

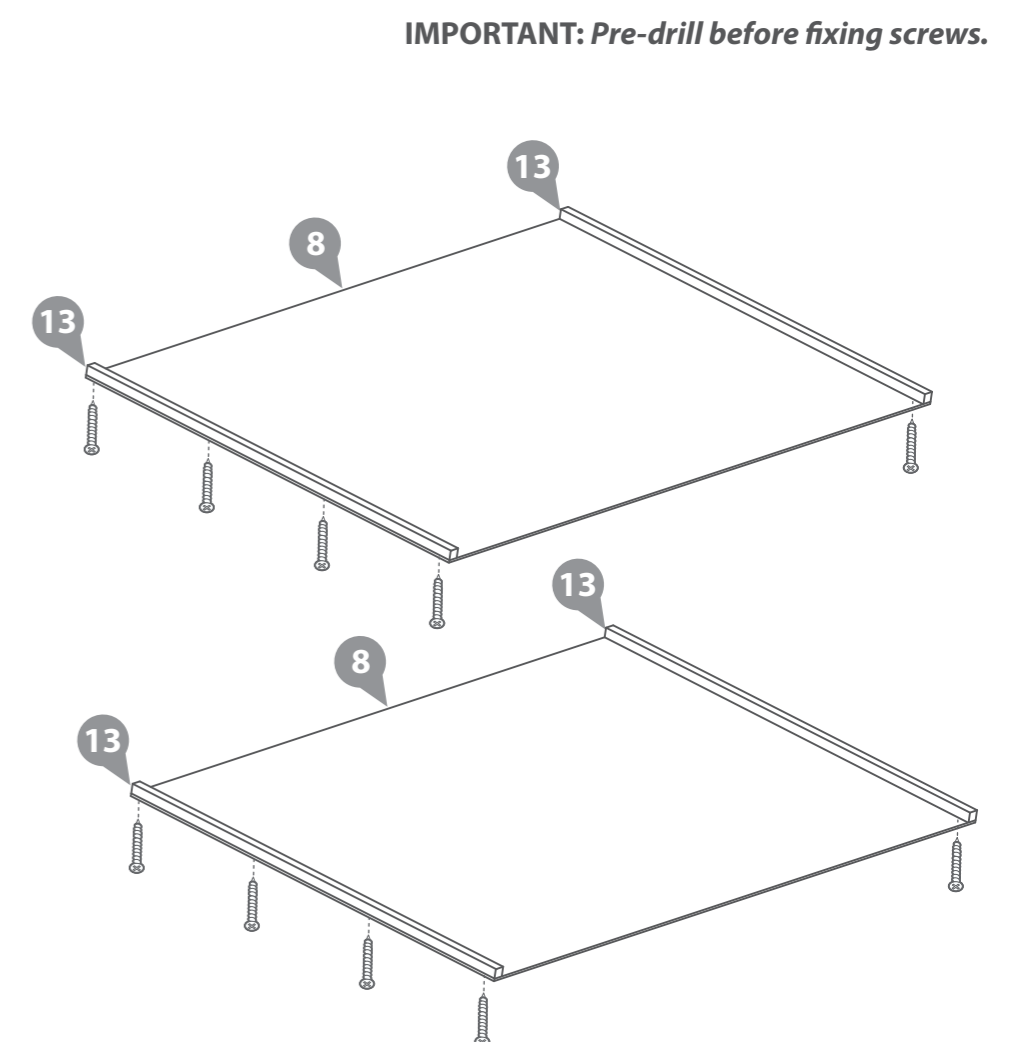

Step 10

Parts Needed - No.8 QTY 2

Fix the roof panels onto the top of the building using 28x30mm screws, ensuring to be flush on the sides and equal spacing at the front and back of the building

28x30mm Screws

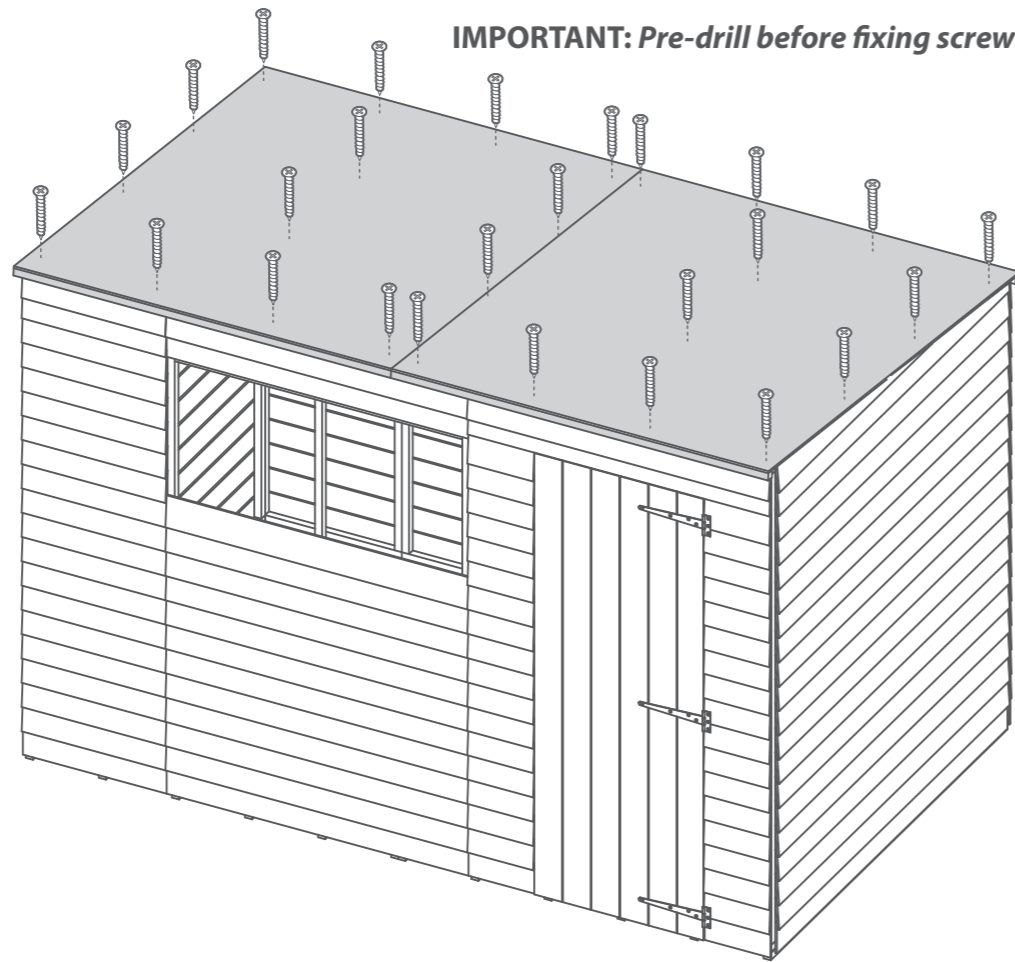
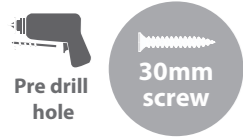

IMPORTANT: Pre-drill before fixing screws.

Step 12

Parts Needed - No.26 QTY 1

Cut the felt (No.26) into 2 sheets of 3050mm and lay onto roof as shown in diagram ensuring there is a 50mm overhang around each side. Nail using felt tacks

130xFelt tacks

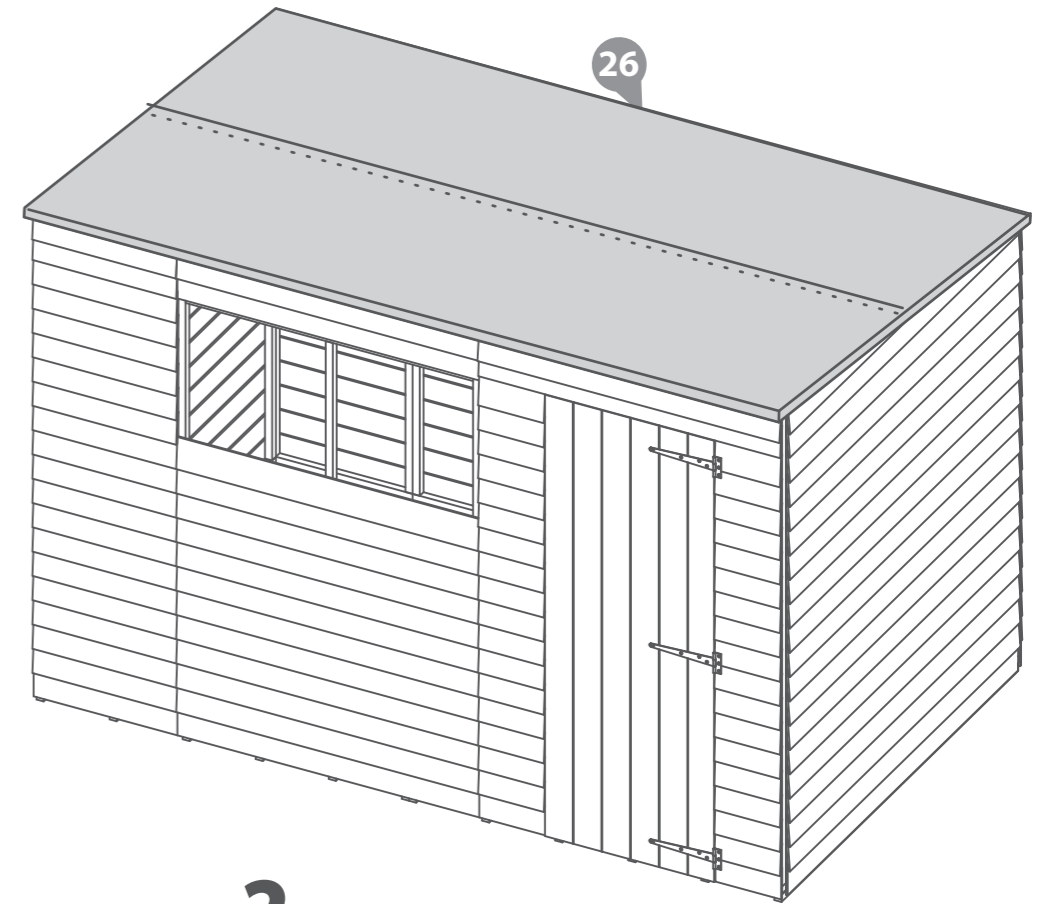

IMPORTANT: Pre-drill before fixing screws.

Step 11

Fix the building to the floor using 28x40mm screws, ensuring to go through the panel framing and into the floor

28x40mm Screws

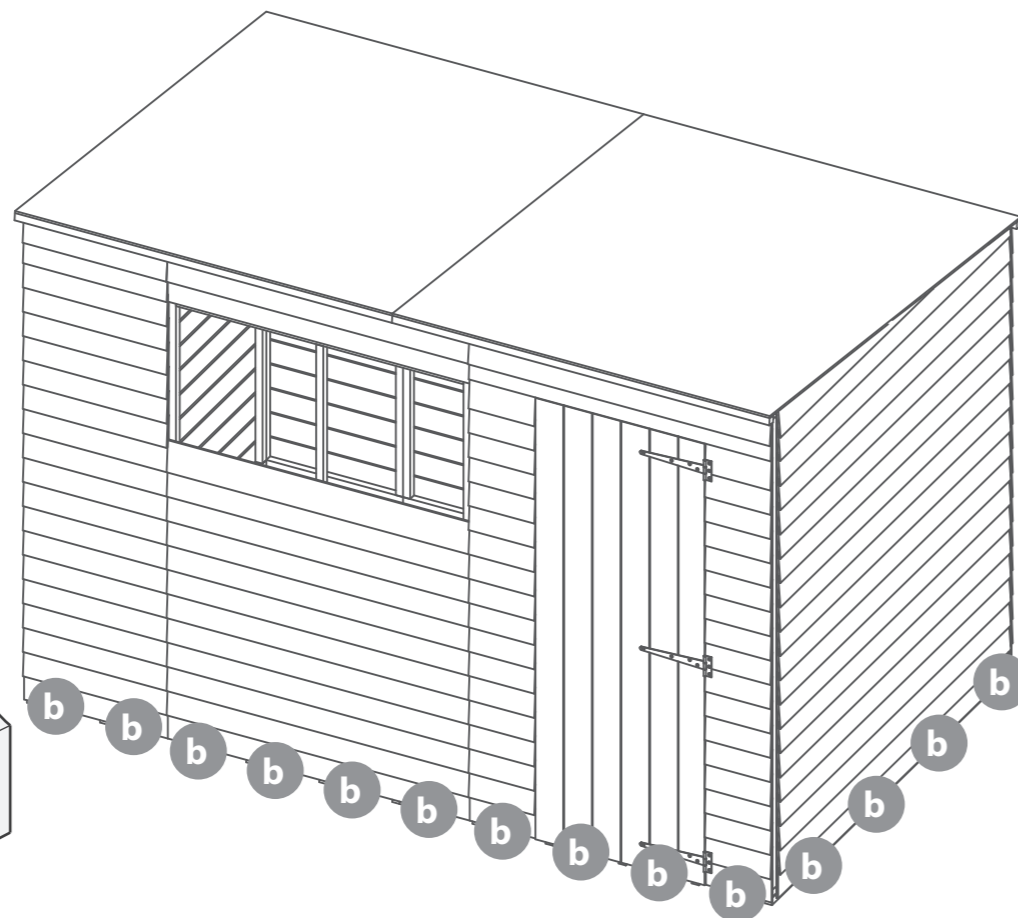
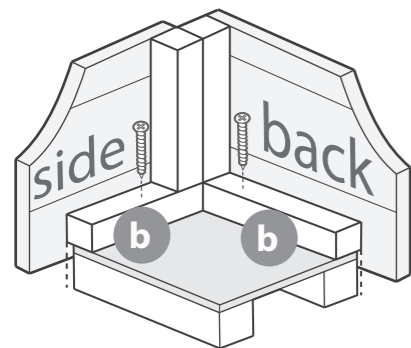
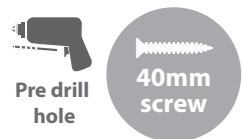

IMPORTANT: Pre-drill before fixing screws.

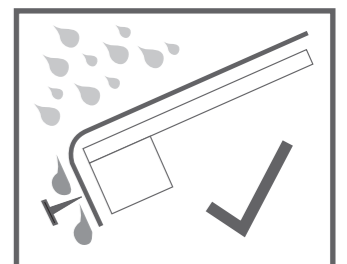
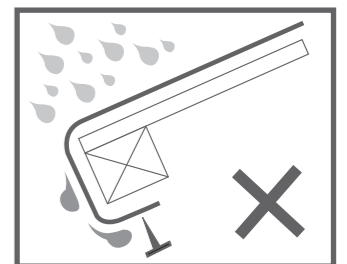
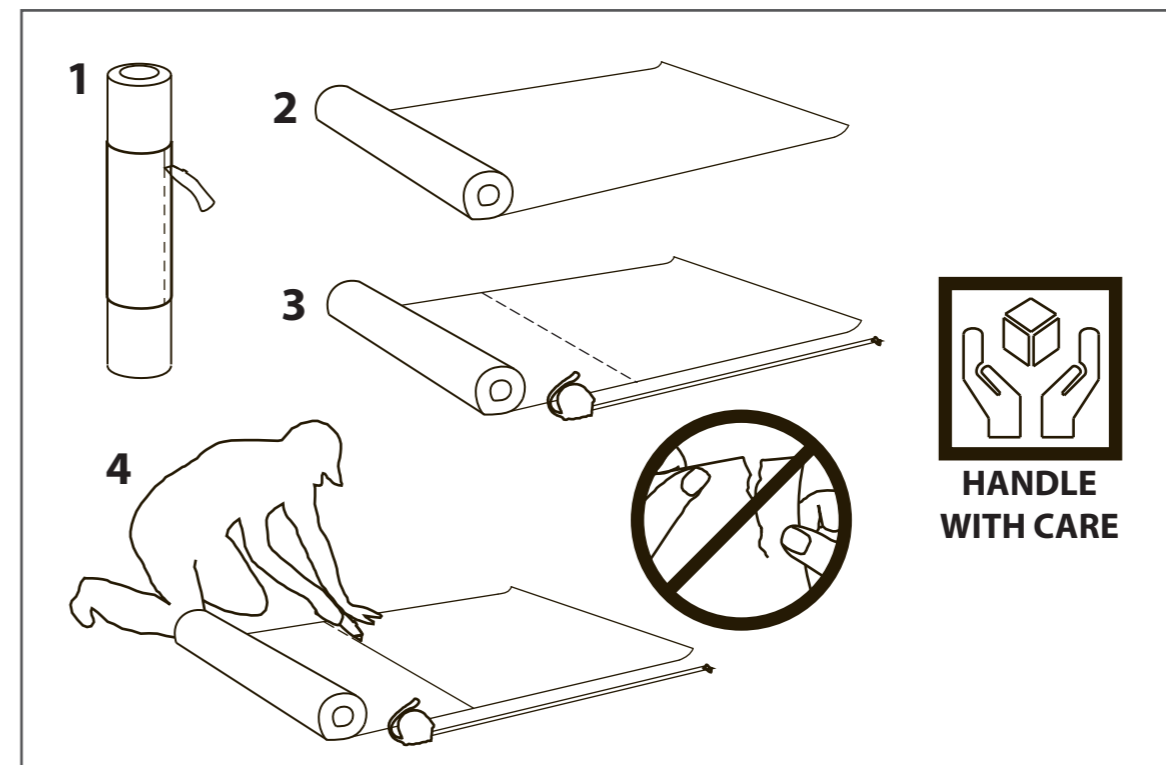
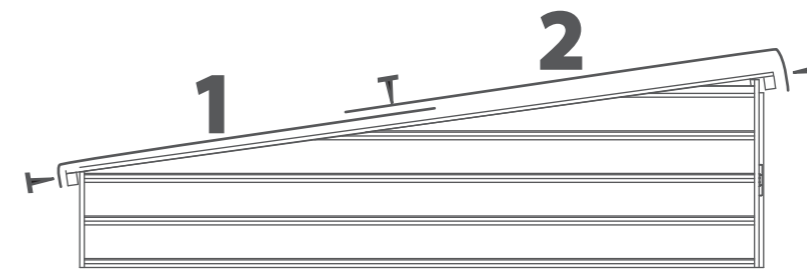

Step 13

- Parts Needed** - No.14 QTY 4
 - No.15 QTY 3
 - No.16 QTY 1
 - No.22 QTY 2
 - No.23 QTY 1

- a** Fix 4x Window strips (No.14) to the framing along the outside edge of the window gap using 3x30mm screws per strip.
- b** Place the Plastic cill (No.23) into the window panel as shown in the illustration. Fix to framing using 3x20mm screws
- c** Fit the Styrene sheets (No.22) on top of the window cill.

**For added weather protection fit your windows using silicone sealant around the outside edges.*

***When positioning the styrene sheets ensure there is an equal distance on all sides.*

- d** Attach the 4x Window Cover trims (No.15 and No.16) to either side of the windows and the centre. Secure into place using 3x30mm screws per strip.

3x20mm Screws
24x30mm Screws

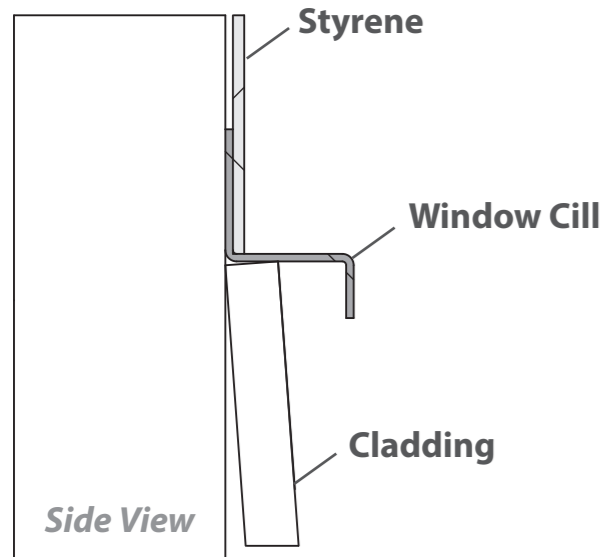
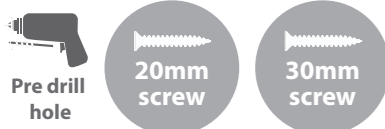

IMPORTANT: Pre-drill before fixing screws.

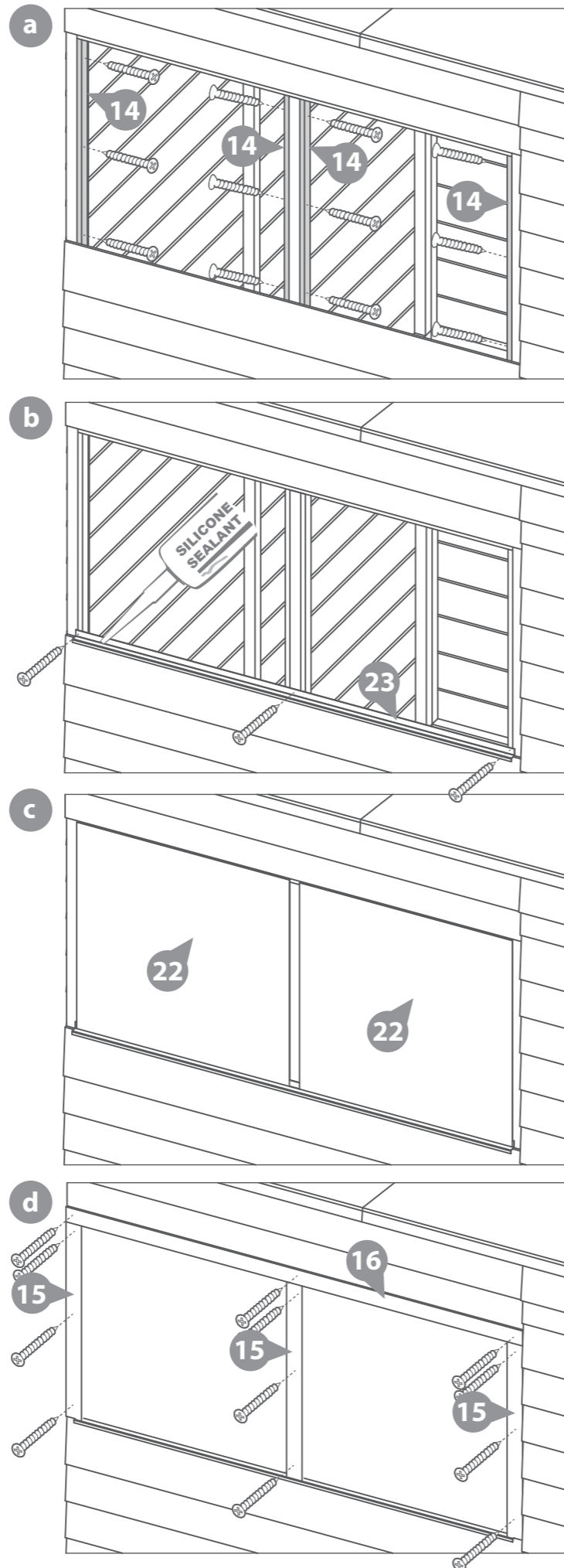

Step 14

- Parts Needed** - No.17 QTY 4
 - No.18 QTY 4

Fix the cover trims (No.17 and No.18) to the corners and the joins of the building, secure using 3x30mm for each cover trim

24x30mm Screws



IMPORTANT: Pre-drill before fixing screws.

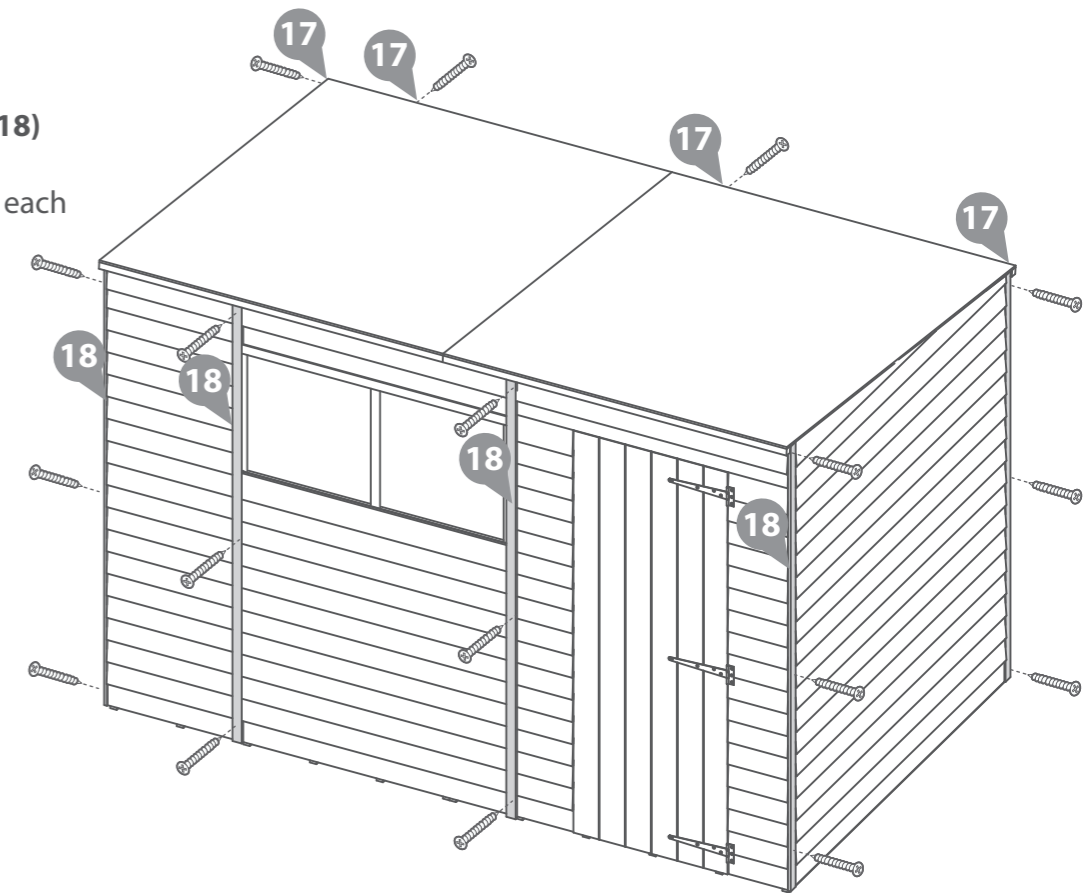

Step 15

- Parts Needed** - No.19 QTY 4
 - No.20 QTY 2

Fix the Fascias (No.19 and No.20) to each side of the building, secure using 3x30mm Screws per fascia.

18x30mm Screws



IMPORTANT: Pre-drill before fixing screws.

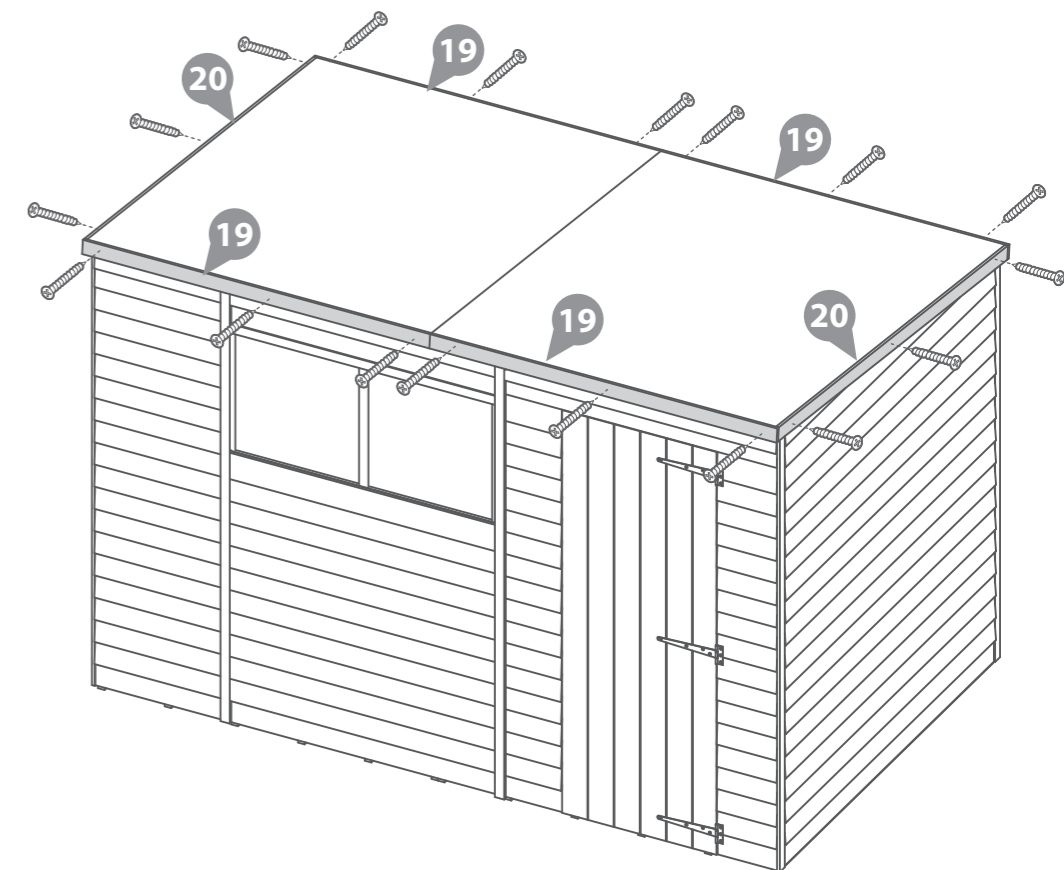

Step 16

Parts Needed - No.12 QTY 1
- No.21 QTY 2

Fix the Door Beading strips (No.21) to the door panel framing, secure using 4x30mm Screws per strip.

Fix the door block (No.12) onto the door framing using 2x50mm Screws

8x30mm Screws
2x50mm Screws

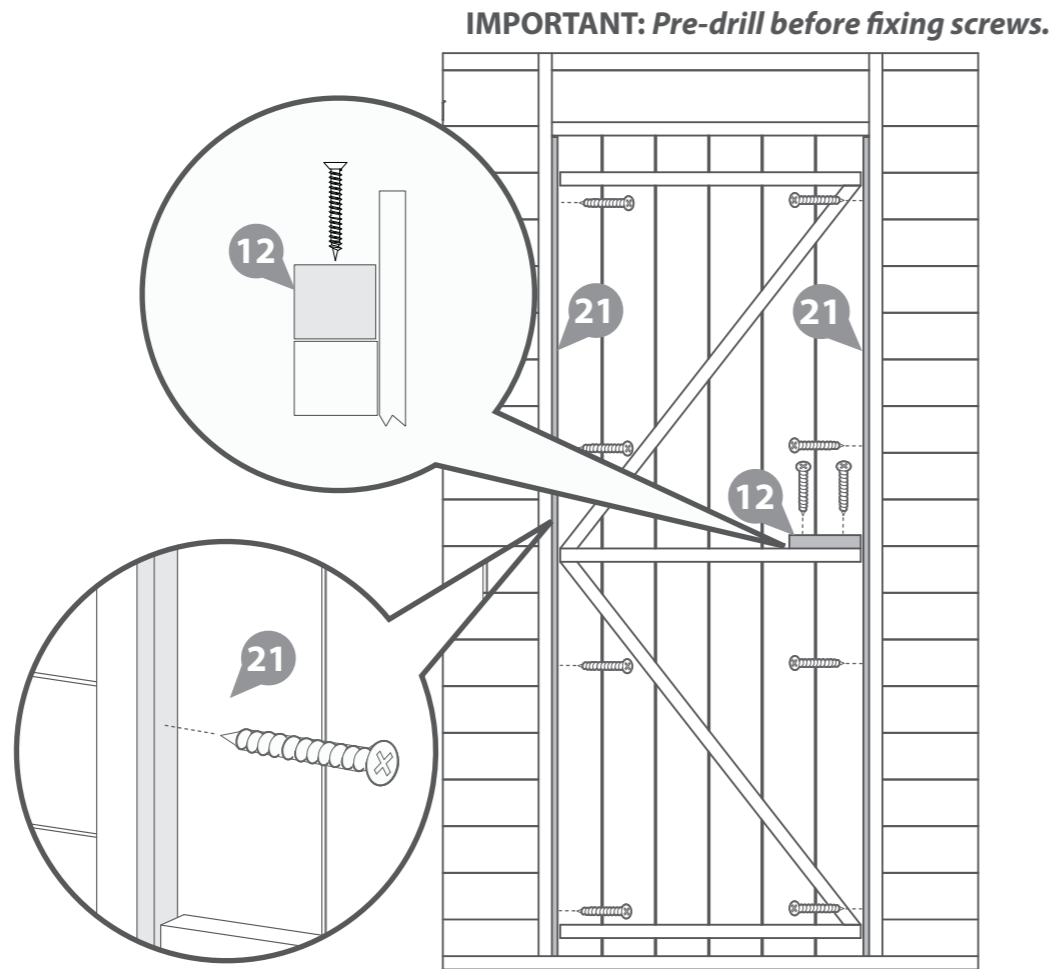
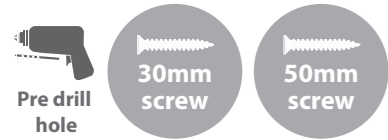

Step 17

Parts Needed - No.24 QTY 2
- No.25 QTY 1

Fix the Turn Buttons (No.24) to the door panel, ensuring that the turn buttons catch the door, secure using 2x30mm screws

Fix the Hasp and Staple (No.25) onto the door and door panel, secure using 7x30mm screws, ensuring the screws go through the framing

9x30mm Screws

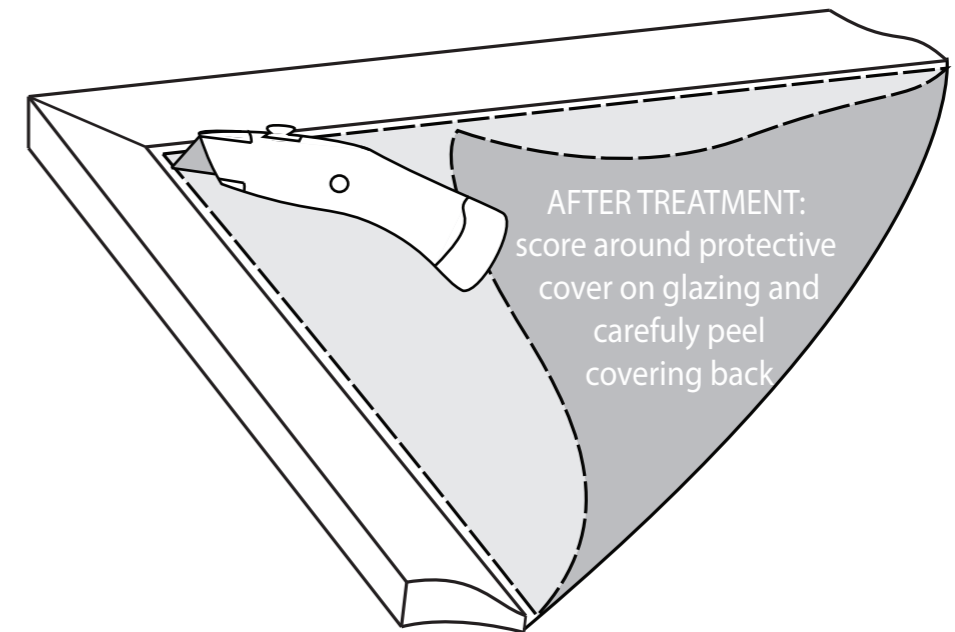
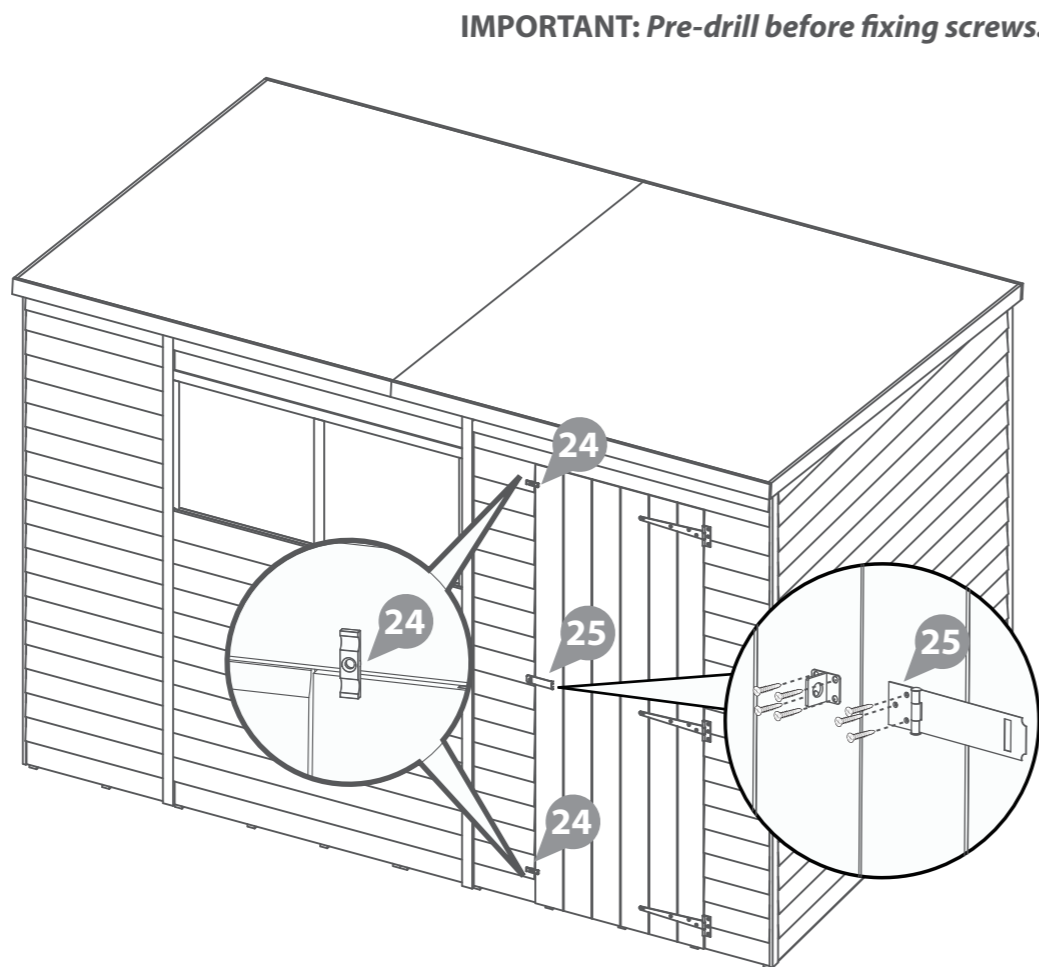
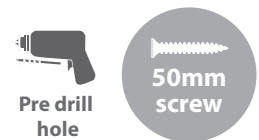

All our garden buildings have been designed and manufactured with care and attention to be the perfect addition to your outdoor space. To ensure you do get the best out of your new garden building and to increase the longevity we advise that you follow the product instructions and our manufacturer's recommendations as detailed below. Thank you for choosing a Mercia Garden product!

1 Choosing the most suitable location for your garden building...

A minimum of 60cm should be left around the perimeter of your garden building to allow access for maintenance, annual treatment and to allow air flow around the building.

Where possible you should avoid placing your garden building underneath large trees to prevent the tree causing damage to the building.

2 Preparing the base for your garden building...

All our buildings must be built on a firm, level base to ensure the longevity of the building and prevent the wood from distorting. We recommend either concrete, concrete slabs or a wooden base, such as our 'Portabase'.

The base should be slightly smaller than the external measurement of the building, i.e. the cladding should overlap the base, creating a run off for water and preventing water from pooling underneath the building.

We also recommend that the floor of the garden building is a minimum of 25mm above the surrounding ground level to avoid flooding.

3 After installation...

Once your garden building has been installed it will need to be treated as soon as possible and annually to prevent the timber from deteriorating and to waterproof it. This is required to maintain the anti-rot guarantee.

Dip Treated buildings - Require a preservative treatment to protect against rot and decay and a waterproof treatment to prevent water ingress

Pressure Treated buildings - Require a waterproof treatment to prevent water ingress

Log Cabins/Insulated Garden Rooms - Are supplied untreated and require a preservative and waterproofing treatment

We also recommend using a silicon sealant on the inside and outside of the windows as soon as possible after assembly and treatment to fully seal the windows.

Roofing felt/covering should be checked annually and replaced or fixed accordingly.

4 General maintenance and wood characteristics

As wood is a natural material it may be affected by the following:

Shrinkage and warping - The timber used in the construction of your garden building will have retained some of its natural moisture content. The moisture content of the timber will vary, depending upon prevailing environmental conditions, which will result in the components either naturally expanding or contracting. As the components dry out shrinkage may occur. A good waterproofing treatment from the start is the best protection to minimise the effect of moisture loss/intake.

In extended periods of very warm weather getting some moisture to the building will help the overall balance. You can do this by spraying it down lightly with a garden hose. In contrast after snow fall try to remove the snow as best as possible from the roof to prevent moisture intake and to remove the extra weight.

Top tip - using a garden brush will help you to reach the highest part of the building to remove snow and any debris left from bad weather.

Damp and mould - During the winter months, cold and damp conditions can result in an increased amount of moisture within your garden building, especially when used infrequently. Condensation can form on the timber and other items stored within your garden building. If left this moisture is likely to cause mould and mildew. To prevent the build-up of moisture, we recommend leaving the door or windows of your building open from time to time, to allow the fresh air to circulate. We also advise against storing wet or damp items in your garden building as this will also increase the level of moisture in the building. If mould or mildew does start to form within your building we recommend using an anti-mould cleaner to remove it and to prevent it spreading, which if left untreated could permanently damage your garden building.

Splits, cracks and knots - You may notice small splits and cracks in some components or holes may appear where knots shrink and fall out. This will not affect the structure of your Garden building however if you wish to fill them this can be easily done using any good quality wood filler.

Sap - is naturally occurring in wood and may appear in some boards of your garden building. If you wish to remove the sap, we advise waiting until it is dry and then using a sharp knife to carefully remove it. If the removal of the sap causes a hole in the timber, we recommend using a good quality wood filler to fill it.

For more handy hints and tips on how to care and maintain your garden building please refer to the MGP Customer Portal at www.mgplogistics.co.uk

Any further questions?

Contact our
Customer Service
Team on:
01636 821215

1 Manufacturer's Warranty

All Mercia Garden Products are supplied with a 1 year warranty on all parts against manufacturing defects.

This warranty does not cover movement, warping or splitting of timber products over time.

This warranty will be voided if any of the following occur:

1. The building has been customised or modified/adapted in any way.
2. The person claiming is not the original purchaser of the building.
3. Any damage has been caused by or as a result of misuse.
4. The building has not been maintained and cared for in accordance to our advisories and manufacturer's recommendations.
5. The building has not been treated annually or as per the manufacturer's recommendations, please ensure receipts are kept to validate this claim.
6. The building has not been erected, fitted or installed as per the supplier instructions.
7. The building has not been erected on a suitable sized firm flat, solid level concrete/slab base or placed on pressure treated bearers.
8. The building is or has been placed with 2 feet (60cm) of any obstructions (walls, trees, plants, fences etc.) which can allow moisture to penetrate the timber.
9. The roofing felt has been incorrectly fitted or damaged allowing water ingress, or not properly maintained.
10. Any windows and joints have not been sealed, inside and out, with silicone or other watertight sealant.
11. Any timber has been cut, pierced or drilled without subsequent application of approved cut-end treatment.

2 Anti-rot Guarantee

Mercia Garden Products offer a 10 year anti-rot guarantee on all dip treated (a preparatory treatment) and 15 years on all pressure treated products. This guarantee covers solid timber against rot, decay, blue stain and insect attack.

To validate the guarantee the building must be treated with a recognised wood preserver/water proof top coat (as detailed within manufacturer's recommendations) as soon as possible after assembly and annually thereafter.

This guarantee does not cover movement, warping or splitting of timber products over time.

This guarantee will be voided if any of the following occur:

1. The building has been customised or modified/adapted in any way.
2. The person claiming is not the original purchaser of the building.
3. Any damage is caused by or as a result of misuse.
4. The building has not been maintained and cared for in accordance to our advisories and manufacturer's recommendations.
5. The building has not been treated annually or as per the manufacturer's recommendations, please ensure receipts are kept to validate this claim.
6. The building has not been erected, fitted or installed as per the supplier instructions.
7. The building has not been erected on a suitable sized firm flat, solid level concrete/slab base or placed on pressure treated bearers.
8. The building is or has been placed with 2 feet (60cm) of any obstructions (walls, trees, plants, fences etc.) which can allow moisture to penetrate the timber.
9. The roofing felt has been incorrectly fitted or damaged allowing water ingress, or not properly maintained.
10. Any windows and joints have not been sealed, inside and out, with silicone or other watertight sealant.
11. Any timber has been cut, pierced or drilled without subsequent application of approved cut-end treatment.