

General Instructions

Please retain product label and instructions for future reference

01DTPRMSHPN1206DDOP-V1

DIP TREATED PREMIUM SHIPLAP PENT 12X6 DOUBLE DOOR OPENING WINDOW

BEFORE YOU START PLEASE READ INSTRUCTIONS CAREFULLY

- Check the pack and make sure you have all the parts listed.
- When you are ready to start, make sure you have the right tools at hand (not supplied) including a Phillips screwdriver, Stanley knife, Wood saw, Step ladder, Hammer and a Drill with 2mm bit.
- Ensure there is plenty of space and a clean dry area for assembly.

LOCATION FOR YOUR GARDEN BUILDING

A minimum of 60cm should be left around the perimeter of your garden building to allow access for maintenance, annual treatment and to allow air flow around the building.

Where possible you should avoid placing your garden building underneath large trees to prevent the tree causing damage to the building.

TIMBER

As with all natural materials, timber can be affected during various weather conditions. For the duration of heavy or extended periods of rain, swelling of the wood panels may occur. Warping of the wood may also occur during excessive dry spells due to an interior moisture loss. Unfortunately, these processes cannot be avoided but can be helped. It is suggested that the outdoor building is sprayed with water during extended periods of warm sunshine and sheltered as much as possible during rain or snow.

Once your garden building has been installed it will need to be treated as soon as possible and annually to prevent the timber from deteriorating and to waterproof it. This is required to maintain the anti-rot guarantee.

Dip Treated buildings - Require a preservative treatment to protect against rot and decay and a waterproof treatment to prevent water ingress

Pressure Treated buildings - Require a waterproof treatment to prevent water ingress

Log Cabins - Are supplied untreated and require a preservative and waterproofing treatment.

BUILDING A BASE

When thinking about where the building and base is going to be constructed: Ensure that there will be access to all sides for maintenance work and annual treatment.

Ensure the base is level and is built on firm ground, to prevent distortion. Refer to diagrams for the base dimensions, The base should be slightly smaller than the external measurement of the building, i.e. The cladding should overlap the base, creating a run off for water. It is also recommended that the floor be at least 25mm above the surrounding ground level to avoid flooding.

TYPES OF BASE

- Concrete 75mm laid on top of 75mm hard-core.
- Slabs laid on 50mm of sharp sand.

Whilst all products manufactured are made to the highest standards of Safety and in the case of childrens products independently tested to EN71 level, we cannot accept responsibility for your safety whilst erecting or using this product.

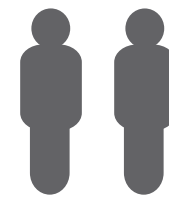

x2

All buildings should be erected by two adults



Winter = High Moisture = Expansion
Summer = Low Moisture = Contraction



2mm Drill bit

For ease of assembly, you **MUST** pilot drill all screw holes and ensure all screw heads are countersunk.



CAUTION

Every effort has been made during the manufacturing process to eliminate the prospect of splinters on rough surfaces of the timber. You are strongly advised to wear gloves when working with or handling rough sawn timber.



For ease of assembly, you will need a tape measure to check dimensions of components.

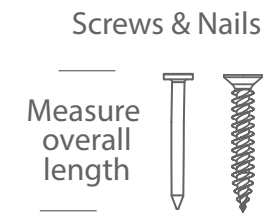

Measure overall length

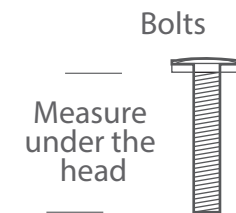

Measure under the head

To identify the fixings required for each step use a measuring tape.

****Protim Aquatan T5 (621)****

Your building has been dip treated with **Aquatan**.

Aquatan is a water-based concentrate which is diluted with water, the building has been treated by the correct application of Aquatan solution and then allowed to dry.

Aquatan is a decorative finish to colour the wood, which is applied industrially to timber fence panels and garden buildings.

Aquatan undiluted contains: boric acid, sodium hydroxide 32% solution, aqueous mixture of sodium dioctyl sulphosuccinat and alcohols: 2, 4, 6-trichlorophenol.



REGISTER FOR YOUR
ANTI-ROT
GUARANTEE TODAY

PLEASE SCAN HERE:



For assistance please contact customer care on: 01636 821215

Mercia Garden Products Limited,

Sutton On Trent,

Newark,

Nottinghamshire,

NG23 6QN

www.merciagardenproducts.co.uk



mercia
GARDEN PRODUCTS
LTD







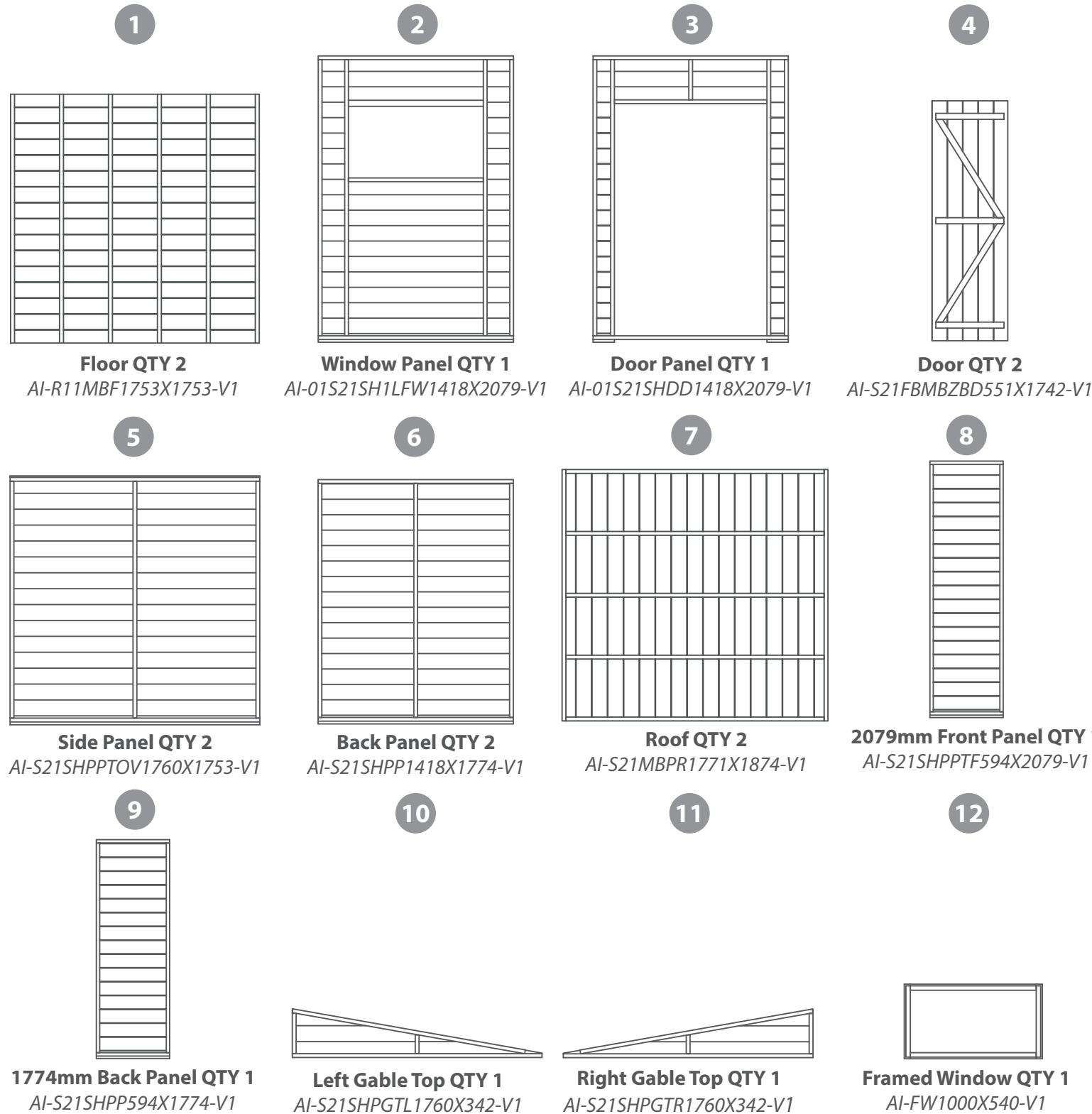
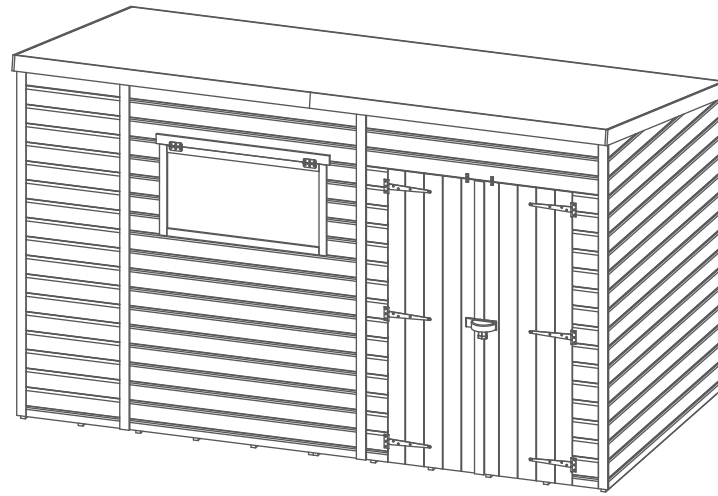

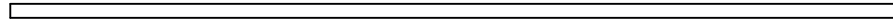
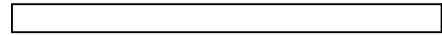
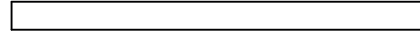
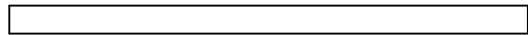
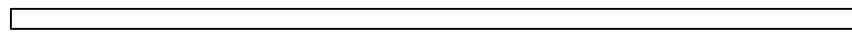

01DTPRMSHPN1206DDOP-V1

Please retain product label and instructions for future reference

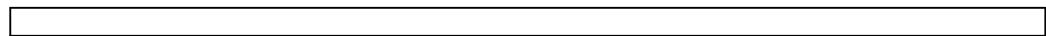
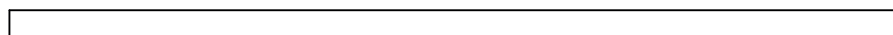
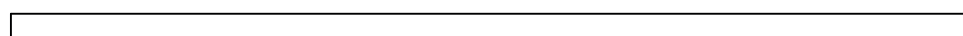
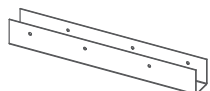
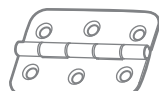
Overall Dimensions:
 Width = 3566mm
 Depth = 1885mm
 Height = 2170mm

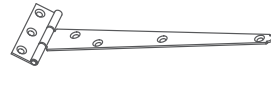
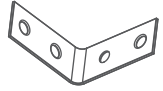
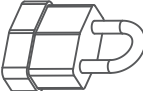
Base Dimensions:
 Width = 3506mm
 Depth = 1753mm

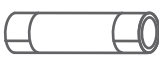

- 13  **Door Block 27x44x160mm QTY 4**
F2744-160MM
- 14  **Ridge Bar 27x70x1715mm QTY 2**
F2770-1715MM
- 15  **Eaves Framing 28x28x1771mm QTY 4**
FS2828-1771MM
- 16  **Door Cover Trims 12x56x860mm QTY 1**
S1256-860MM
- 17  **Door Cover Trims 12x56x820mm QTY 1**
S1256-820MM
- 18  **Window Cover Trim 12x56x1038mm QTY 1**
S1256-1038MM
- 19  **Door Beading Strips 12x40x1686mm QTY 2**
S1240-1686MM
- 20  **Cover Trims 12x56x1770mm QTY 4**
S1256-1770MM
- 21  **Cover Trims 12x5x2072mm QTY 4**
S1256-2072MM
- 22  **Fascias 12x90x1771mm QTY 4**
S1290-1771MM
- 23  **Fascias 12x90x1898mm QTY 2**
S1290-1898MM
- 24  **U-Channel QTY 1**
PI-07-0013
- 25  **Butt Hinge QTY 2**
PI-07-0066
- 26  **Turn Button QTY 4**
PI-07-0034
- 27  **T-Hinge QTY 6**
PI-07-0021
- 28  **Corner Brace QTY 2**
PI-07-0012
- 29  **Padlock QTY 1**
PI-07-0222
- 30  **Lock Hasp QTY 1**
PI-07-0221
- 31  **Casement Stay QTY 1**
PI-07-0007
- 32  **Green Felt QTY 1**
PI-01-0016
- 33  **4m Capping Felt QTY 1**
PI-01-0020

Nail Bag

There may be extra screws present in the nail bag

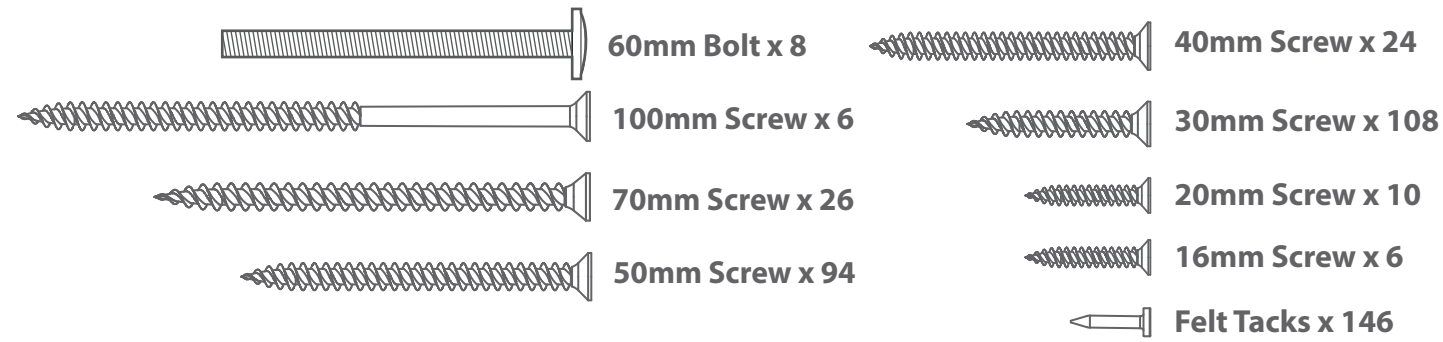

Pre Assembly

Before assembling remove the transportation blocks from the bottom of each panel.

Take care removing the blocks as to not damage the panels. Tap with a flat headed screwdriver and hammer.

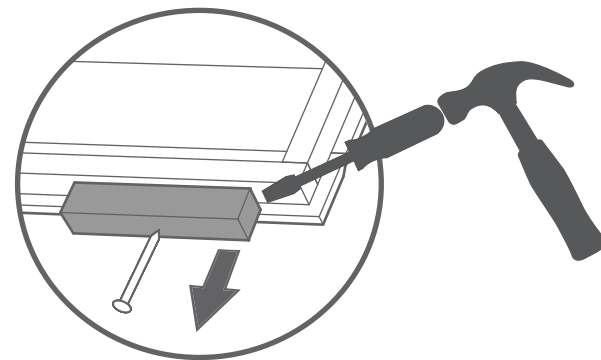

Dispose of the blocks once removed.

Step 1

Parts needed - No.1 QTY 2

Place the Floor Panels (No. 1) upside down onto a firm and level base. Ensure the base has suitable drainage, free from areas where standing water can collect.

Secure the floors together using 12x50mm screws through the floor bearers in an alternating pattern.

Once fixed together turn the floor back the right way up.

10x50mm Screws



Step 2

Parts needed- No.3 QTY 1
-No.4 QTY 2
-No.27 QTY 6

Fix the T Hinges (No.27) onto the doors (No.4) and Door Panel (No.3) as shown using 7x30mm screws per t-hinge

Ensure that the screws go through the cladding and into the framing behind.

42x30mm Screws

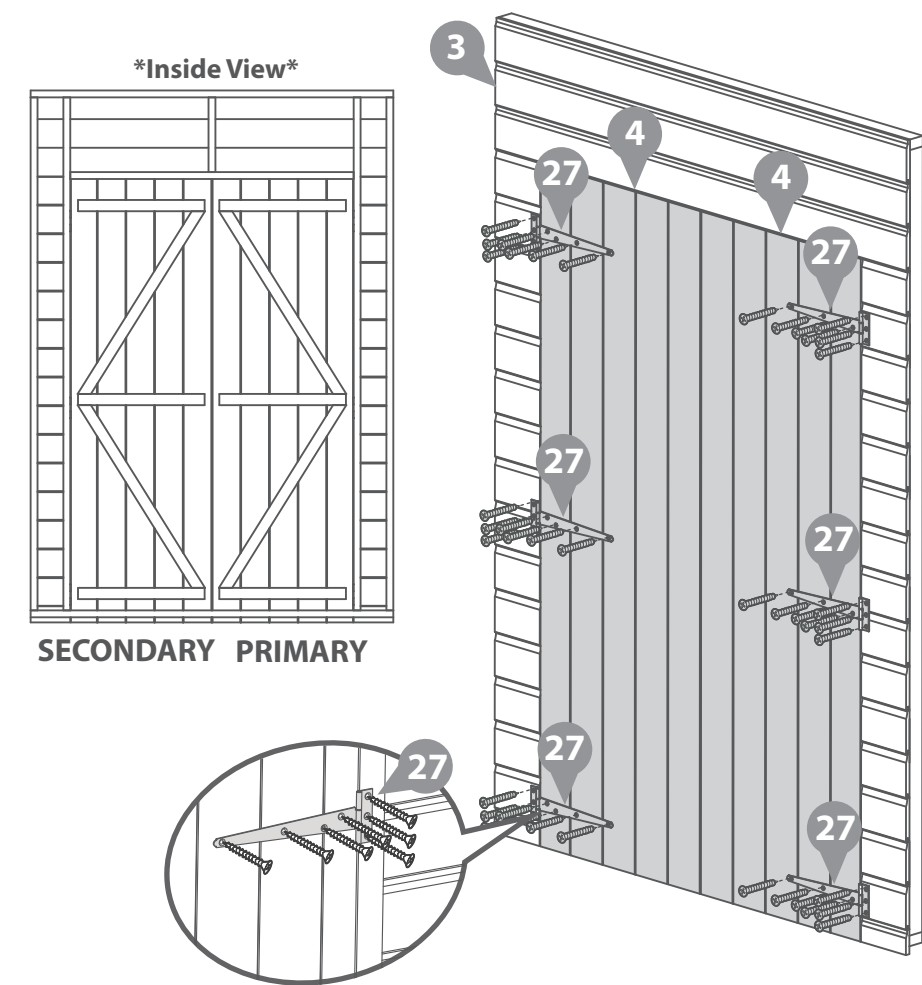
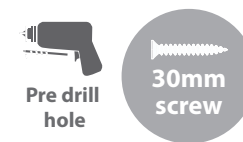

Step 3

Parts needed - No.5 QTY 1
- No.9 QTY 1

Place the Side panel (No.5) and the 1774mm Back Panel (No.9) onto the floor, Fix the panels at the corner using 3x50mm Screws

Do not secure the building to the floor until the roof has been fitted.

Position the panels so there is equal spacing between the floor and cladding on all sides.

3x50mm Screws

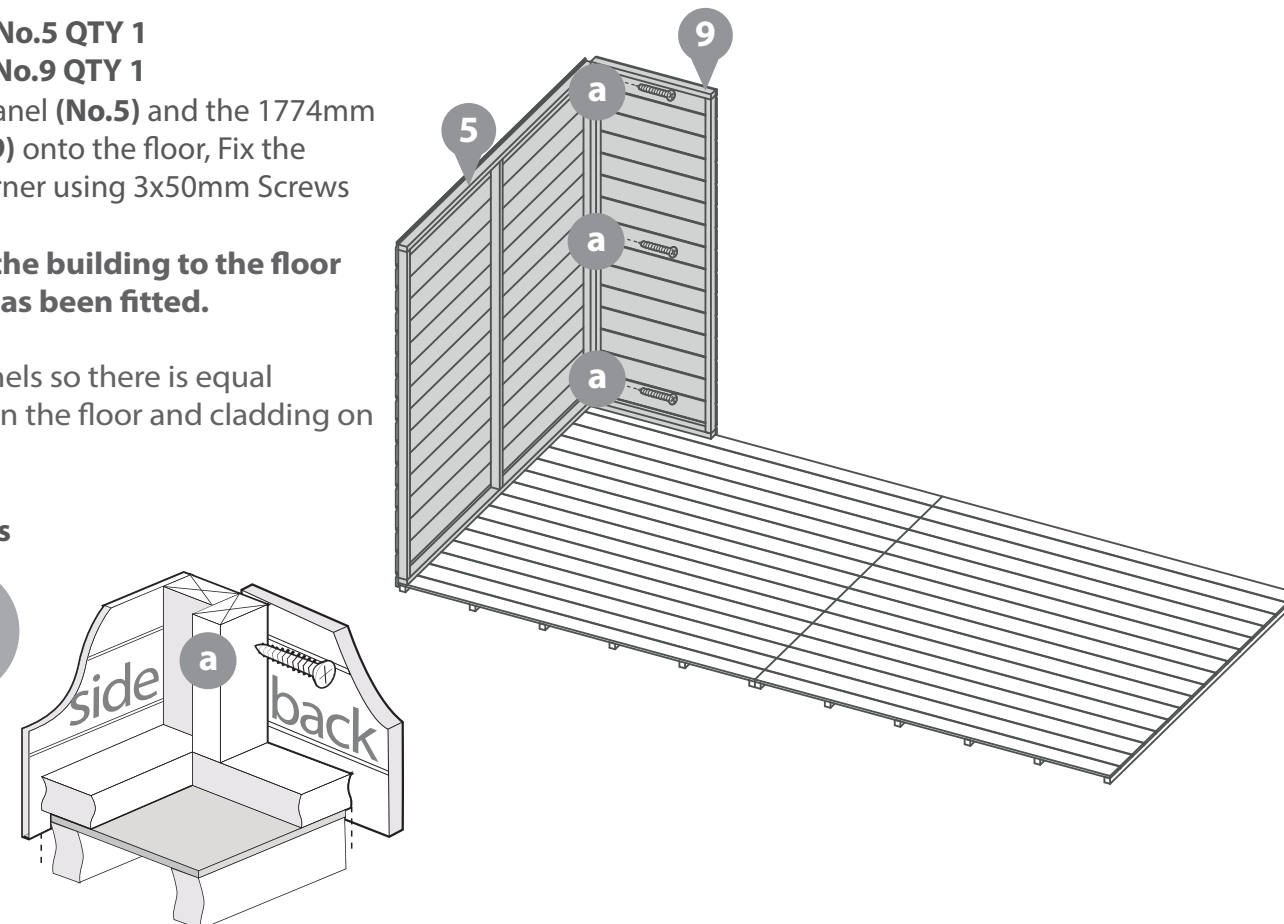
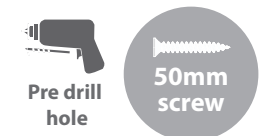

Step 4

Parts needed - No.6 QTY 2

Place the next two Back panel (No.6) onto the floor. Fix the panel to the end of the already standing Small Back Panel using 3x50mm Screws.

Do not secure the building to the floor until the roof has been fitted.

Position the panels so there is equal spacing between the floor and cladding on all sides.

6x50mm Screws

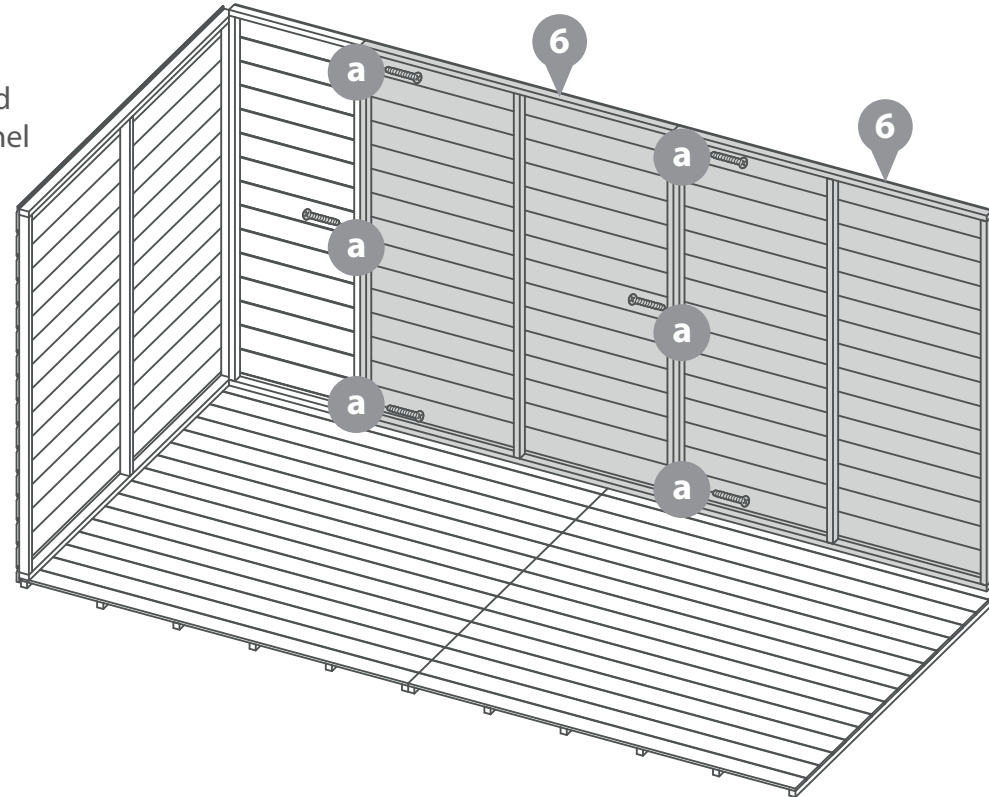
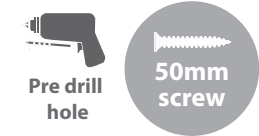

Step 6

Parts needed - No.3 QTY 1

Place the Door panel (No.3) onto the floor, Fix the panel at the corners using 3x50mm Screws

Do not secure the building to the floor until the roof has been fitted.

Position the panels so there is equal spacing between the floor and cladding on all sides.

6x50mm Screws

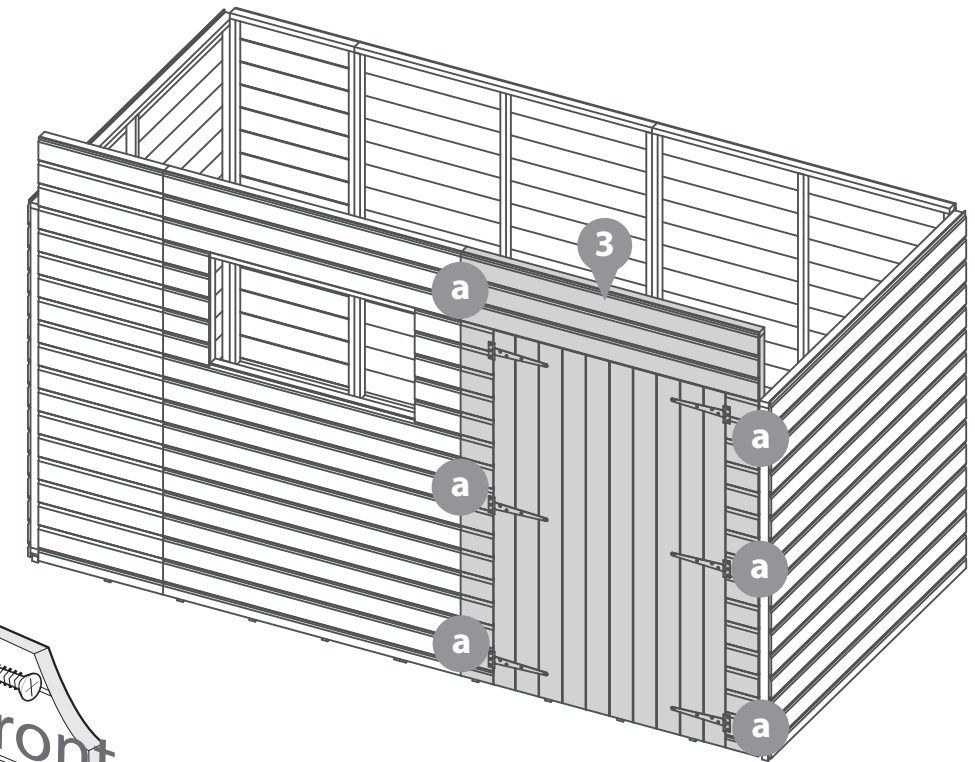
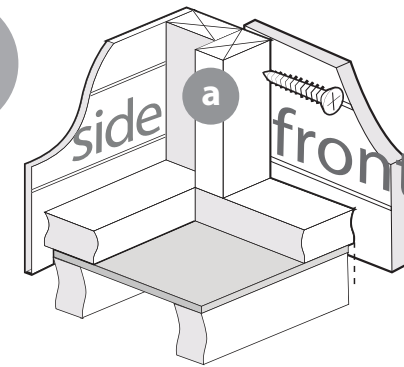

Step 5

Parts needed - No.2 QTY 1
- No.5 QTY 1
- No.8 QTY 1

Place the 2079mm Front Panel (No.8) and the Side panel (No.5) onto the floor, Fix the panels at the corner using 3x50mm Screws.

Place the Window Panel (No.2) along side the 2079mm Front Panel (No.8) and fix at the ends using 3x50mm screws.

Do not secure the building to the floor until the roof has been fitted.

Position the panels so there is equal spacing between the floor and cladding on all sides.

9x50mm Screws

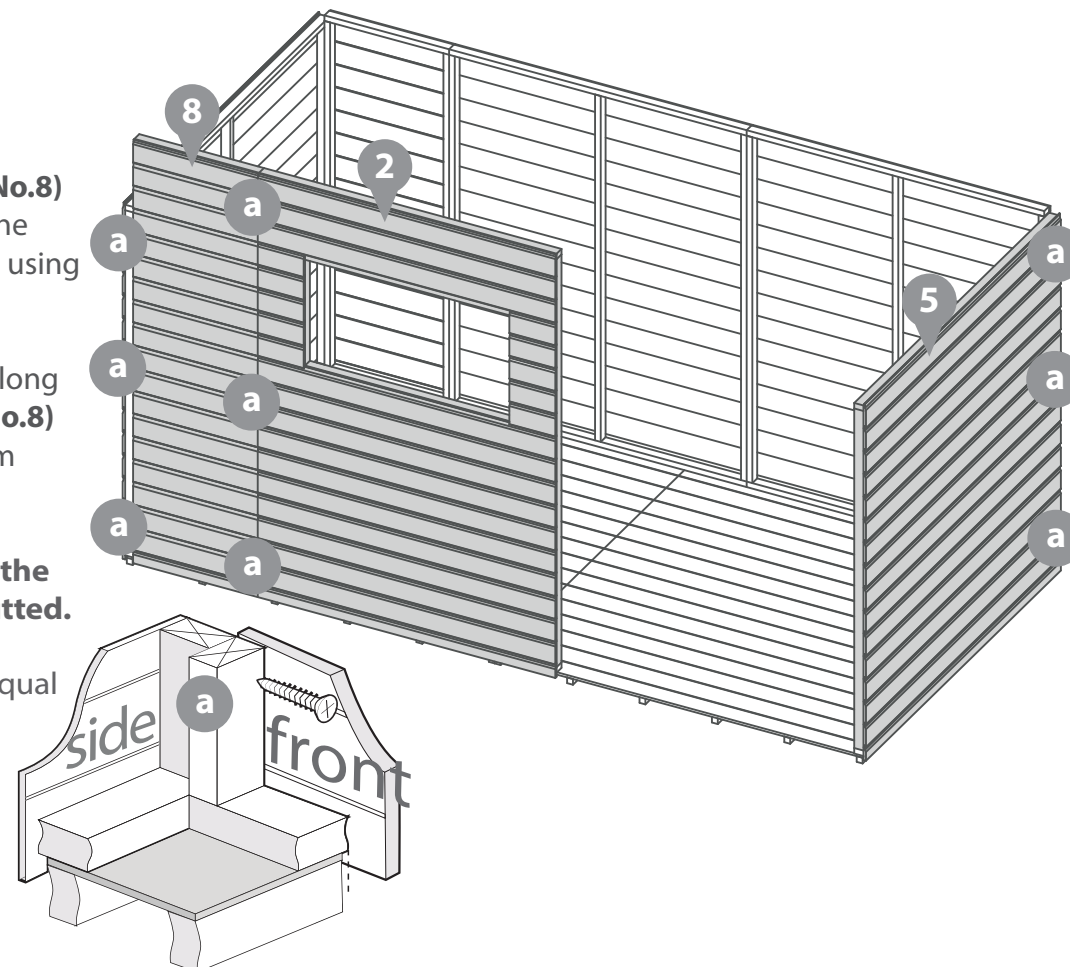

Step 7

Parts needed - No.10 QTY 1
- No.11 QTY 1

Place the Left Gable (No.10) and the Right Gable (No.11) onto the side panels, ensuring the boards interlock.

Secure in place using 4x50mm screws per gable top, screwing in an alternating pattern.

Using 2x50mm screws, fix gables to the front panels at the corners.

12x50mm Screws

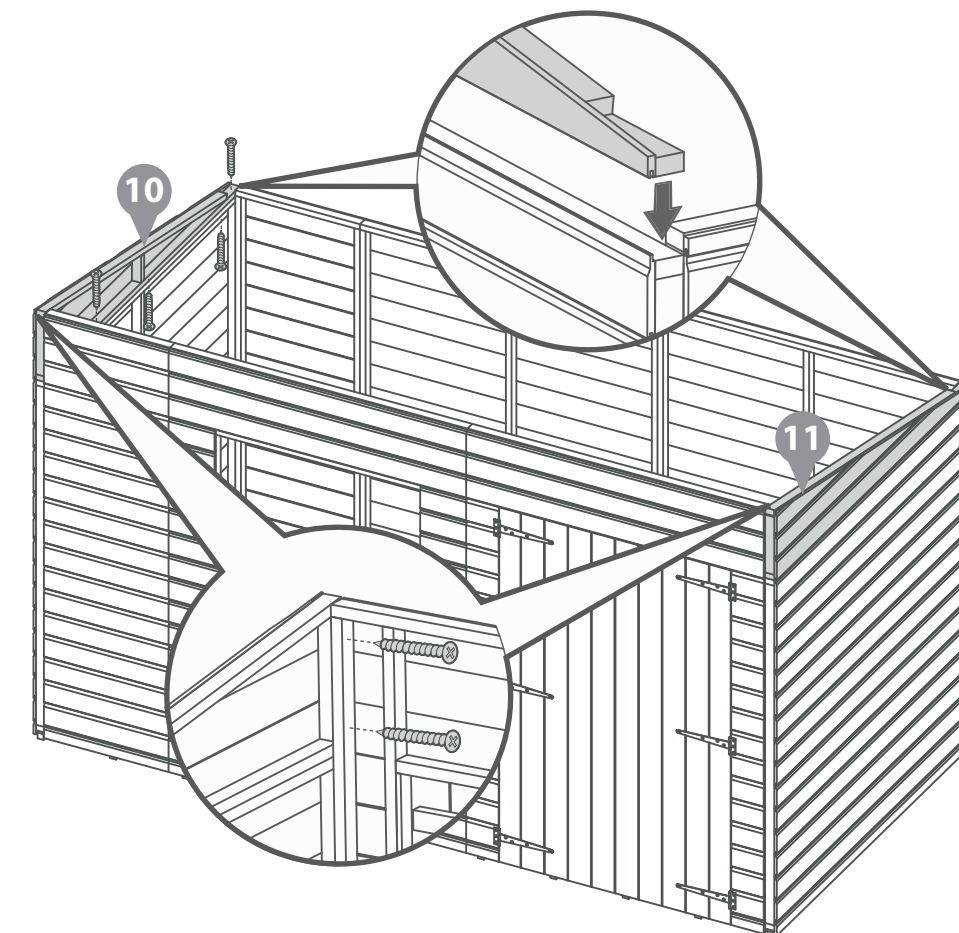
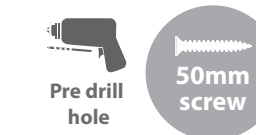

Step 8

Parts Needed - No.14 QTY 2
- No.24 QTY 1
- No.28 QTY 2

Connect the ridge bars (**No.14**) together with the metal "U" (**No.24**) channel, using 10x30mm screws. Ensure the ridge bar sits into the U-channel with equal spacing on each side.

Attach the "L" (**No.28**) brackets to each end of the Ridge support with 2x30mm screws per bracket.

**Ensure the bracket are flush with the ends of the ridge bar.*

14x30mm Screws

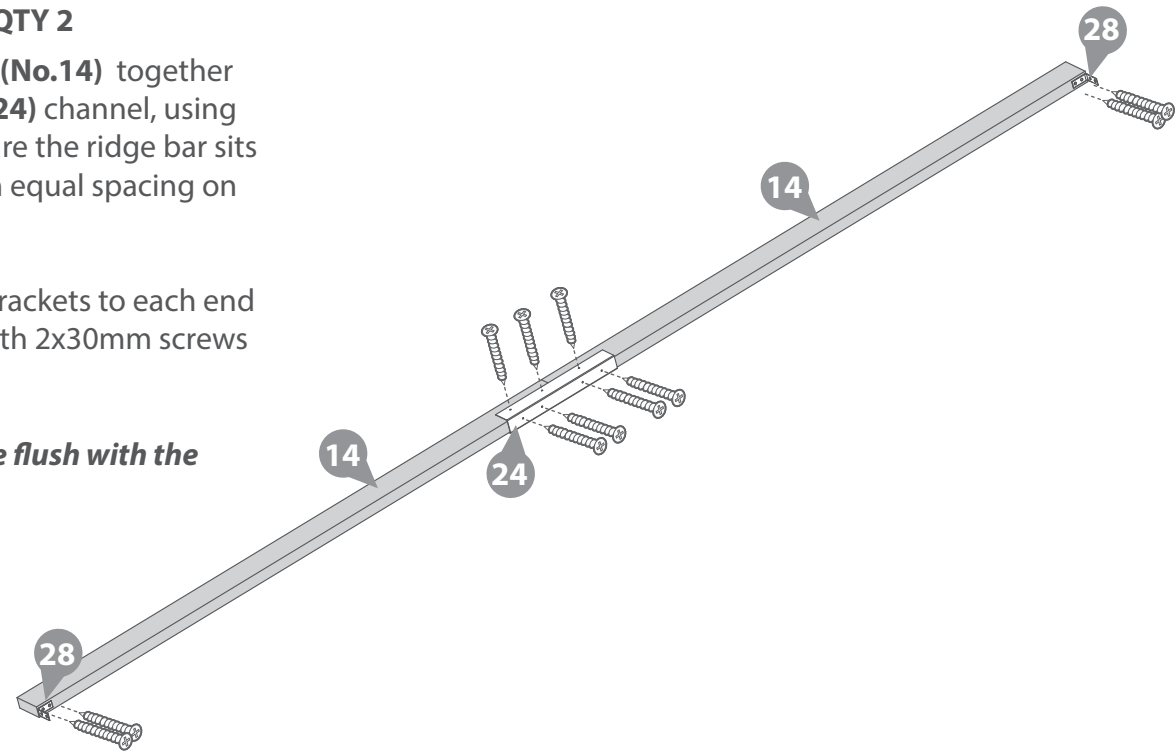
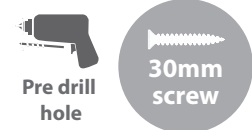

IMPORTANT: Pre-drill before fixing screws.

Step 10

Parts needed - No.7 QTY 2
- No.15 QTY 4

Fix the Eaves framing (**No.15**) to the roof (**No.7**) using 5x50mm screws per eaves framing, screwing through the eaves framing and into the roof framing.

Ensure the eaves framing is flush to the edges of the roof framing before securing

20x50mm Screws

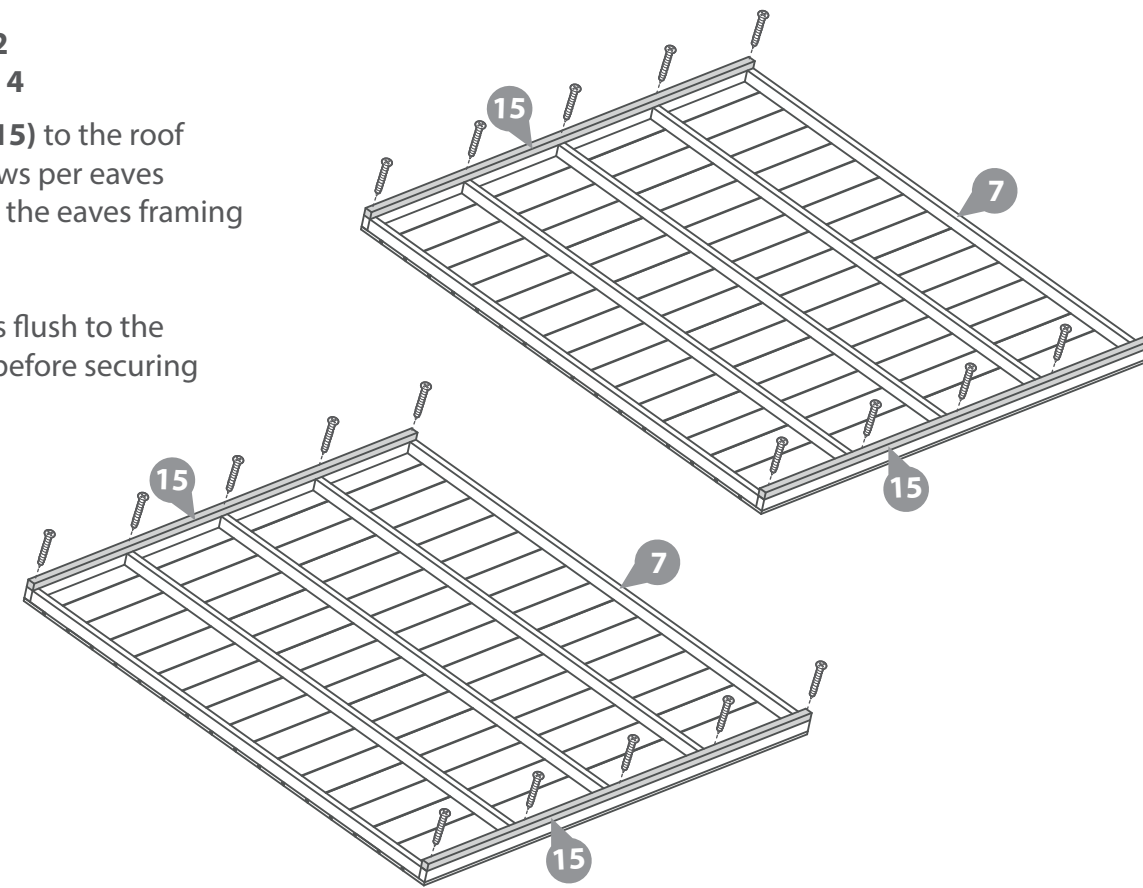
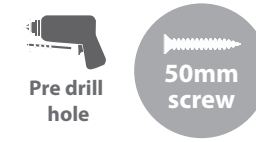

Step 9

Parts needed - No.14 QTY 2
- No.28 QTY 2

Align the ridge bar (**No.14**) between the gables and secure to the central uprights with 2x30mm screws per bracket (**No.28**), as shown in the illustration.

**Ensure the ridge bar is flush with the top framing of the gable tops.*

4x30mm Screws

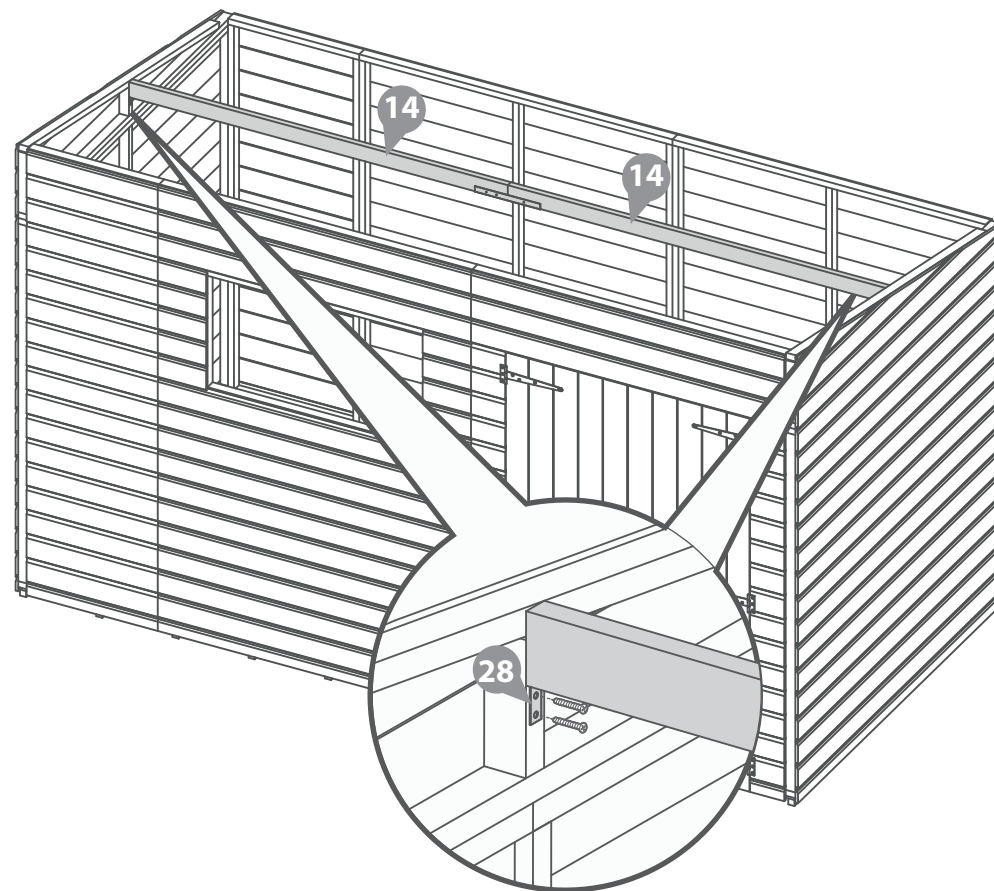
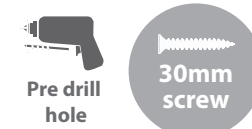

Step 11

Parts needed- No.7 QTY 2

Place the Roofs (**No.7**) onto the top of the building, ensuring the side edges are flush with the building and there is equal spacing at the front and back.

Fix the Roofs together internally, using 4x50mm screws in alternating sides as shown in the diagram.

4x50mm Screws

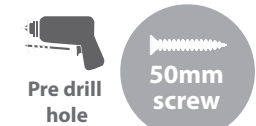

internal view

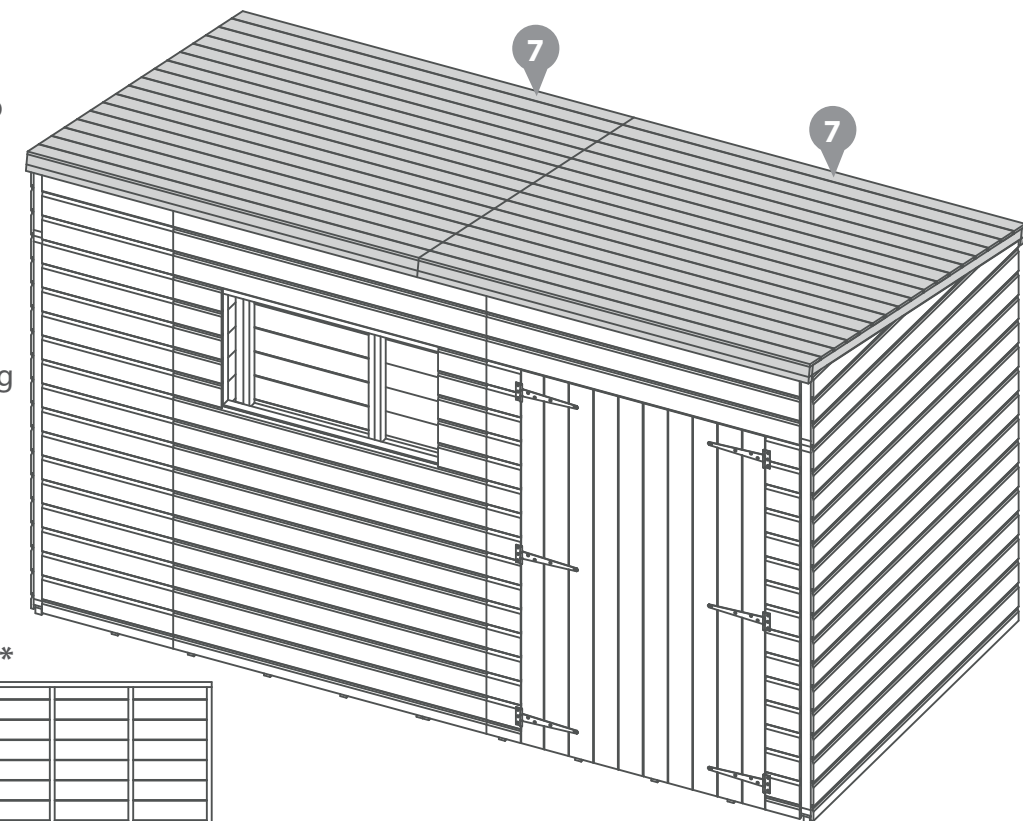
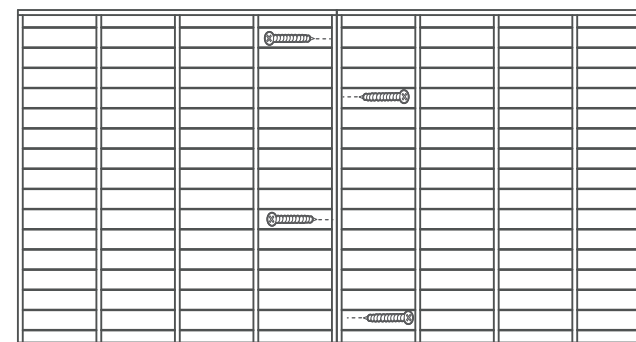

Step 12

Fix the roofs (**No.7**) to the top of the building, ensuring the side edges are flush with the building and there is equal spacing at the front and back.

Using 26x70mm Screws, fix the roof (**No.7**) around each edge, ensuring the screws go through to the panel framing below.

HINT - Follow the nailing line of the framing on the roof panels so that you are more likely to fix through the roof framing into the panel framing below.

26x70mm Screws

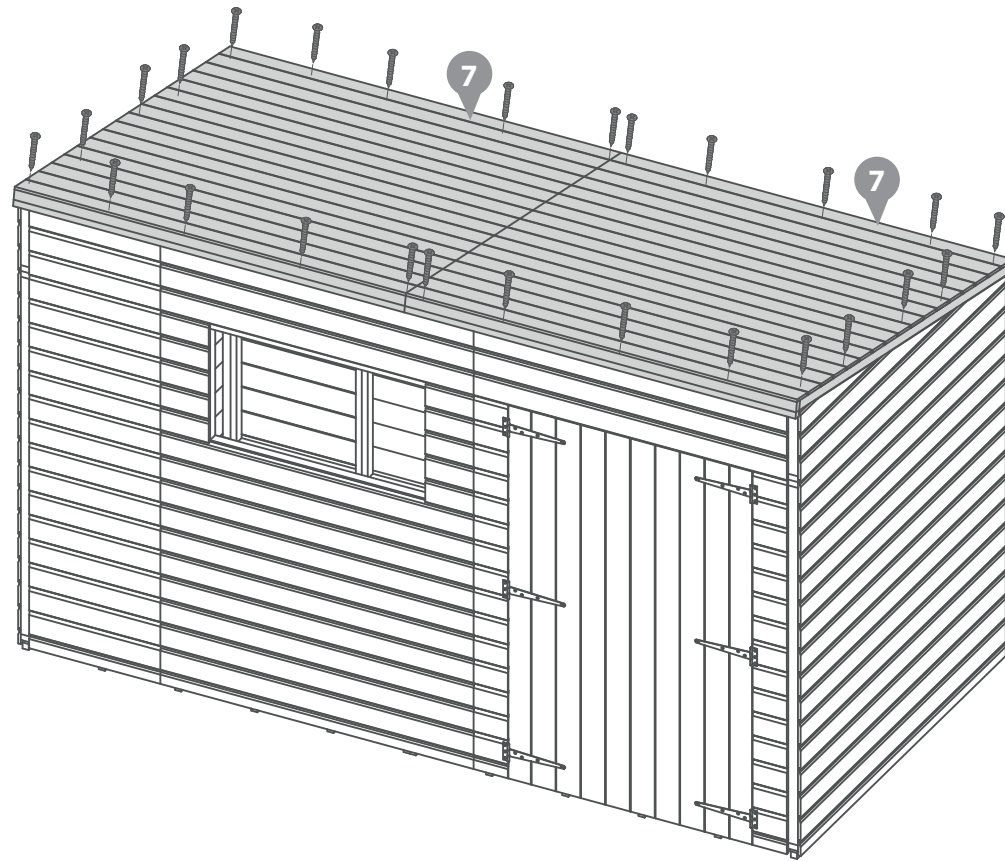
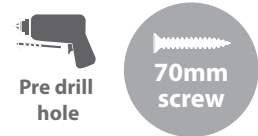

Step 14

Once the roof is fixed, attach the building to the floor with 50mm screws.

Ensure the screws go through the panel into the floor framing

24x50mm Screws

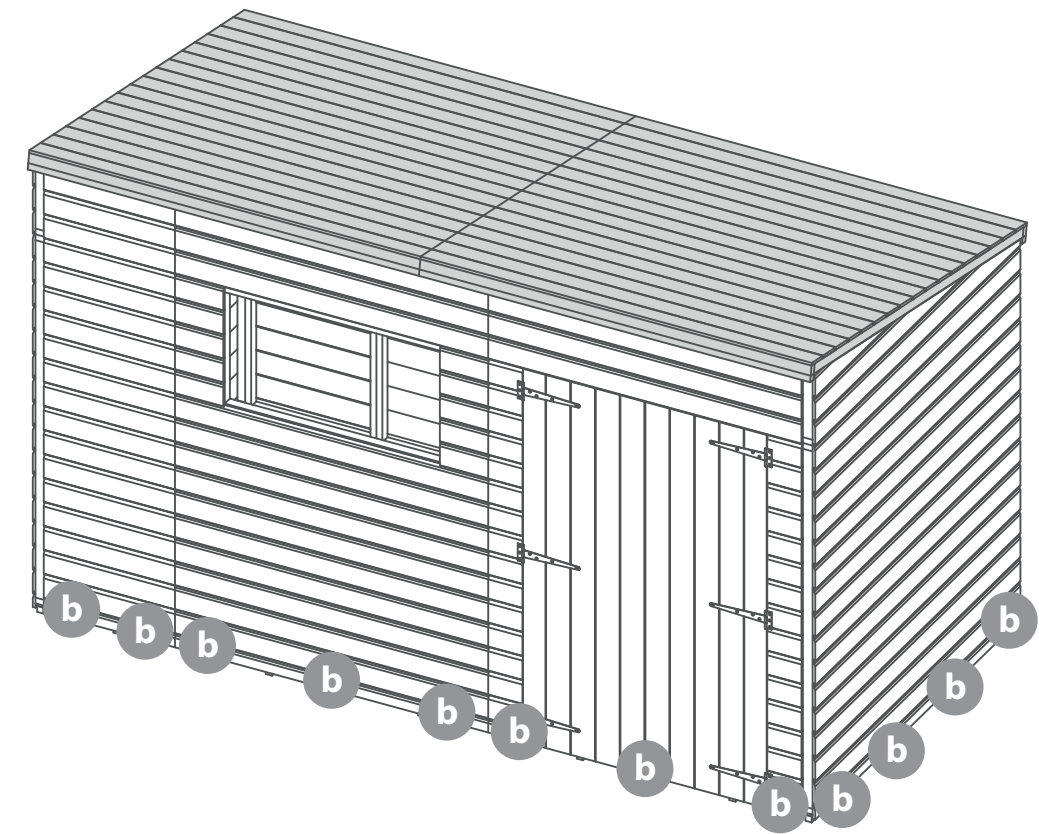
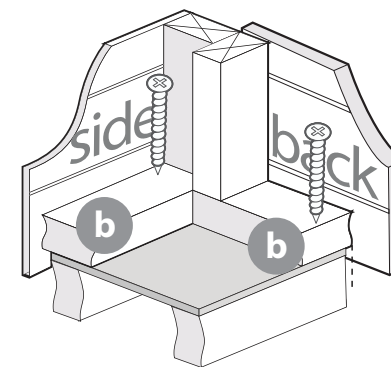

Step 13

Using 6x100mm screws, fix the roof (**No.7**) onto the ridge bar (**No.14**), ensuring to go through the roof framing and into the ridge bar.

6x100mm Screws

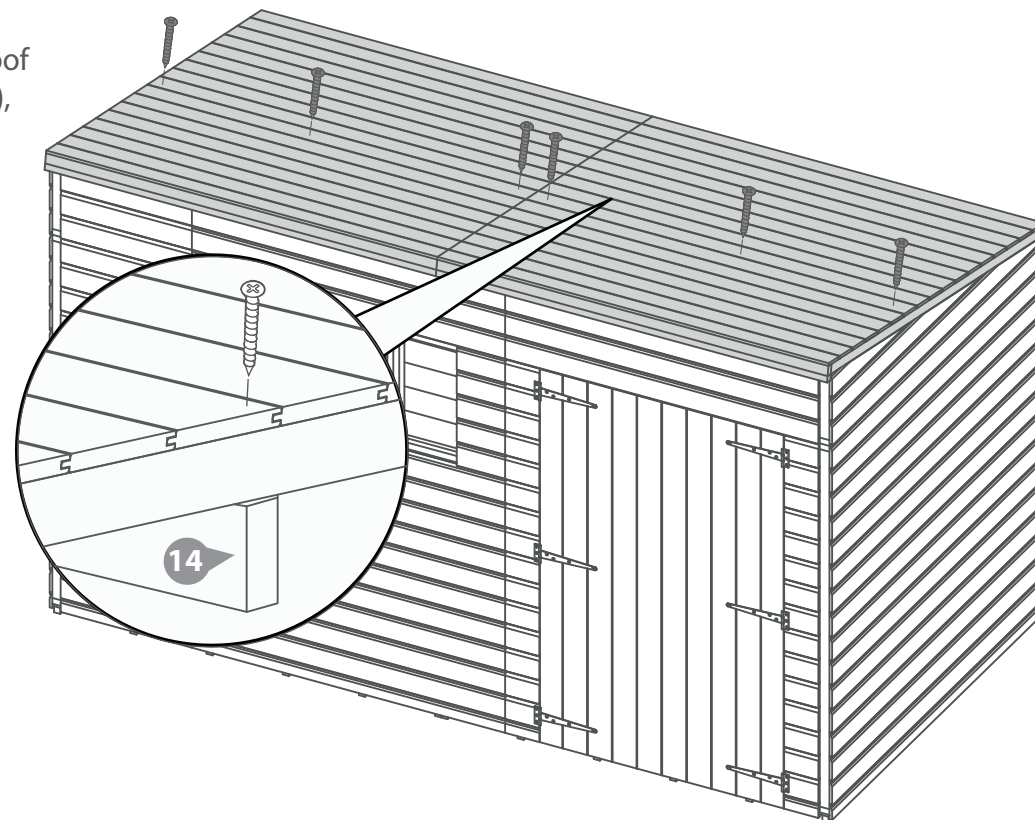

Step 15

Parts needed - **No.16 QTY 1**
 - **No.17 QTY 1**
 - **No.26 QTY 2**

Fix the Door Cover trims (**No.16 & No.17**) to the Primary door (**Left side**), Ensure the cover trims are flush to the top and bottom of the door. secure using 2x20mm screws per cover trim.

Fix the Turn buttons (**No.26**) above each door using 2x30mm screws, Ensure the turn buttons hold the door.

4x20mm Screws
 2x30mm Screws

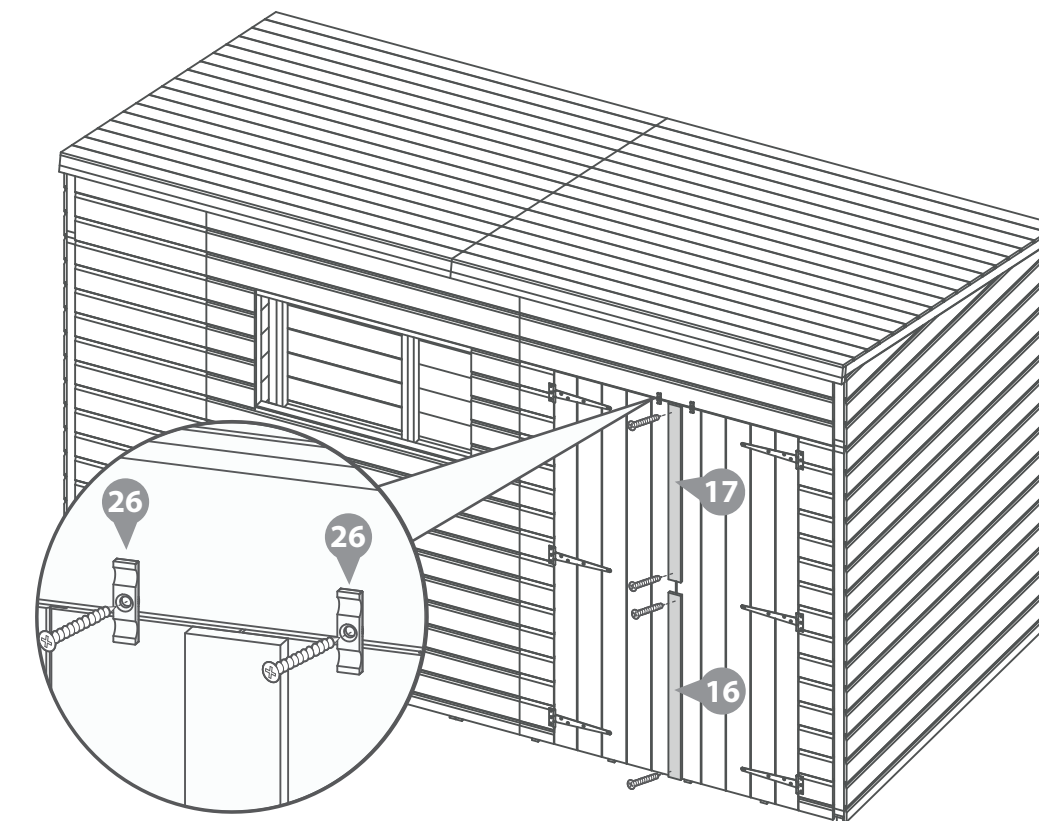

Step 16

Parts needed - No.12 QTY 1
 - No.18 QTY 1
 - No.25 QTY 2

Opening Window

Place the Window Cover Trim (No.18) 11mm over the window opening and fix in place with 3x30mm screws per trim.

3x30mm Screws

If you would like the window (No.12) to be opening use the butt hinges (No.25) to attach the window to the trim. Fix the hinges to the trim using 30mm screws and 16mm to fit the hinges to the window frame.

6x16mm Screws
 6x30mm Screws

Fixed Window

If you would like the window (No.12) to be fixed instead of opening, secure the window to panel using 4x30mm screws per window.

4x30mm Screws

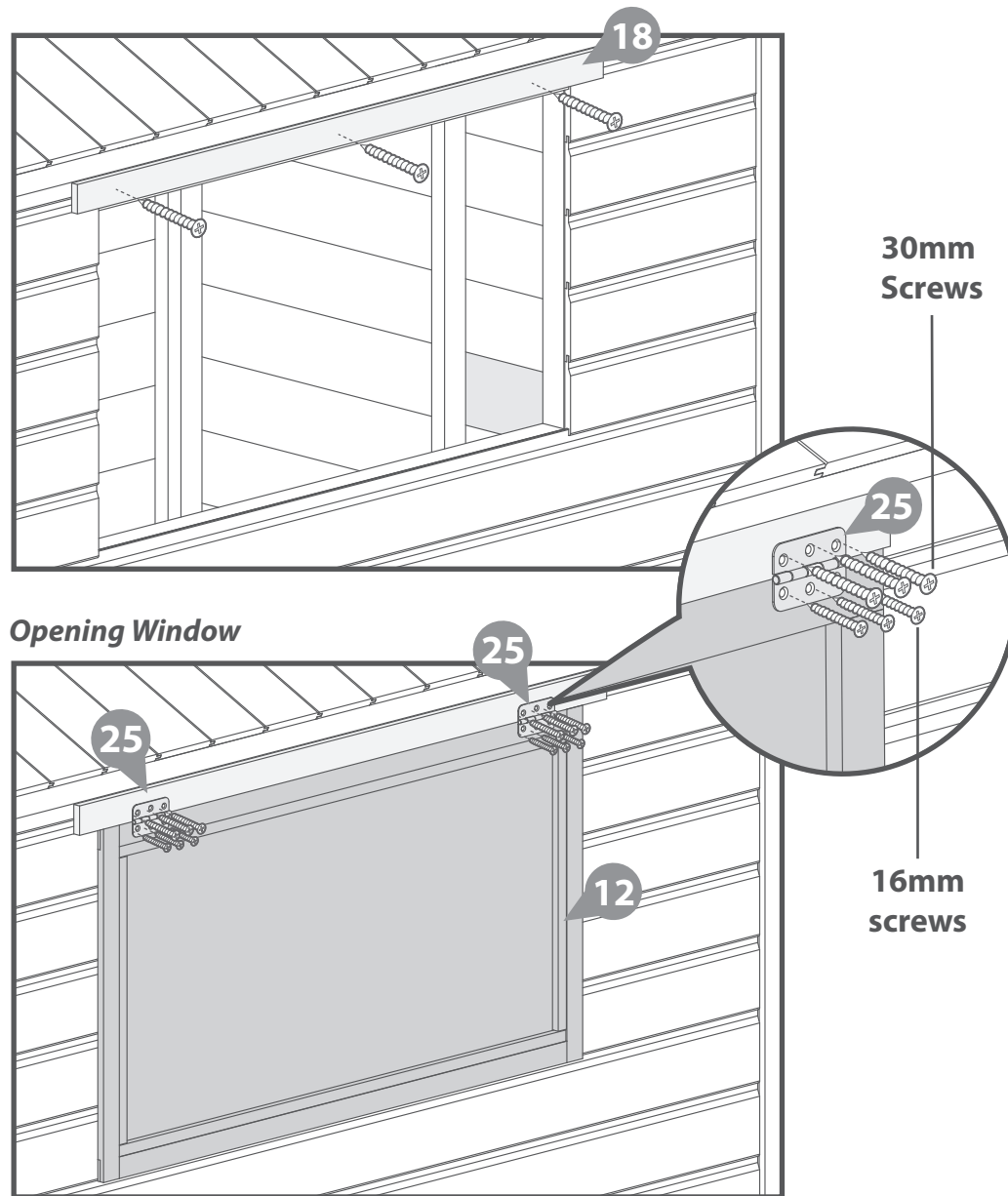

Opening Window

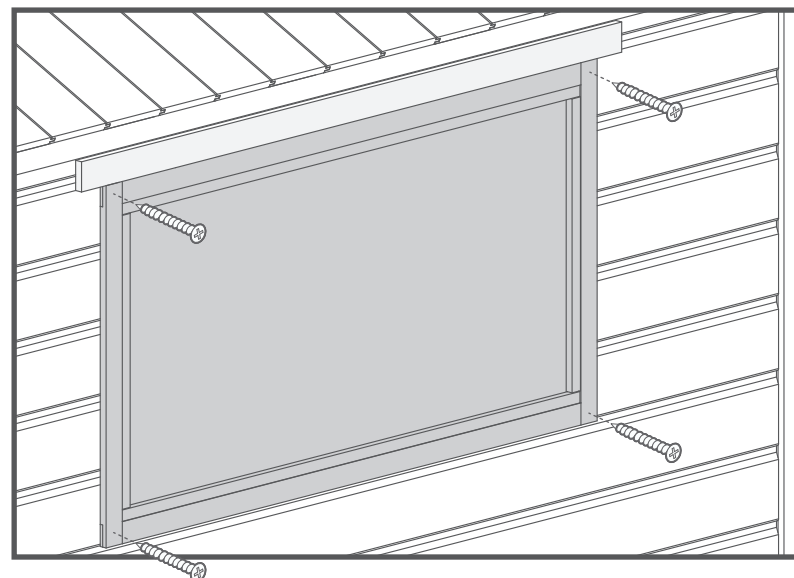

Fixed Window

Step 17

Parts needed- No.31 QTY 1

Fix the casement stay (No.31) to the window and then align the fixings to the window panel framing. Ensure the casement stay fits onto the fixings when closed before securing in place.

6x20mm Screws

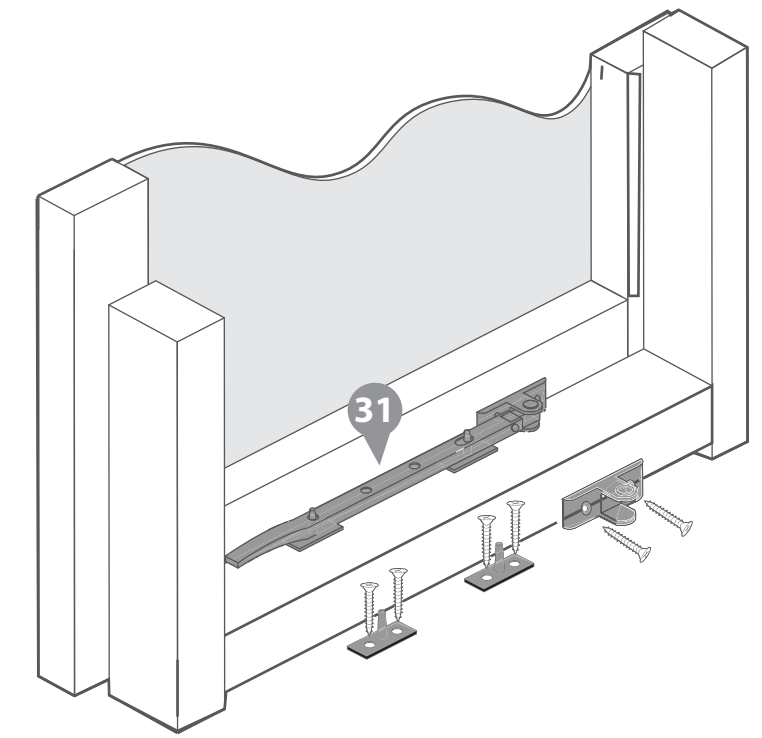

Step 18

Parts needed - No.13 QTY 4
 - No.19 QTY 2
 - No.26 QTY 2

- Fix the Door block (No.13) onto the inside of the top and bottom of the door next to the framing within the Door Panel, secure using 2x40mm screws going through the front of the door boards and into the blocks. Secure the turn button (No.26) onto the door block (No.13) using 1x30mm screw.
- Fix the Door blocks (No.13) along the central framing on the inside of each door as shown in the diagram, using 2x40mm screws through the door cladding and into the block.
- Fix the Door Beading strips (No.19) to the door framing and secure using 4x30mm screws per strip.

9x30mm Screws
 6x40mm Screws

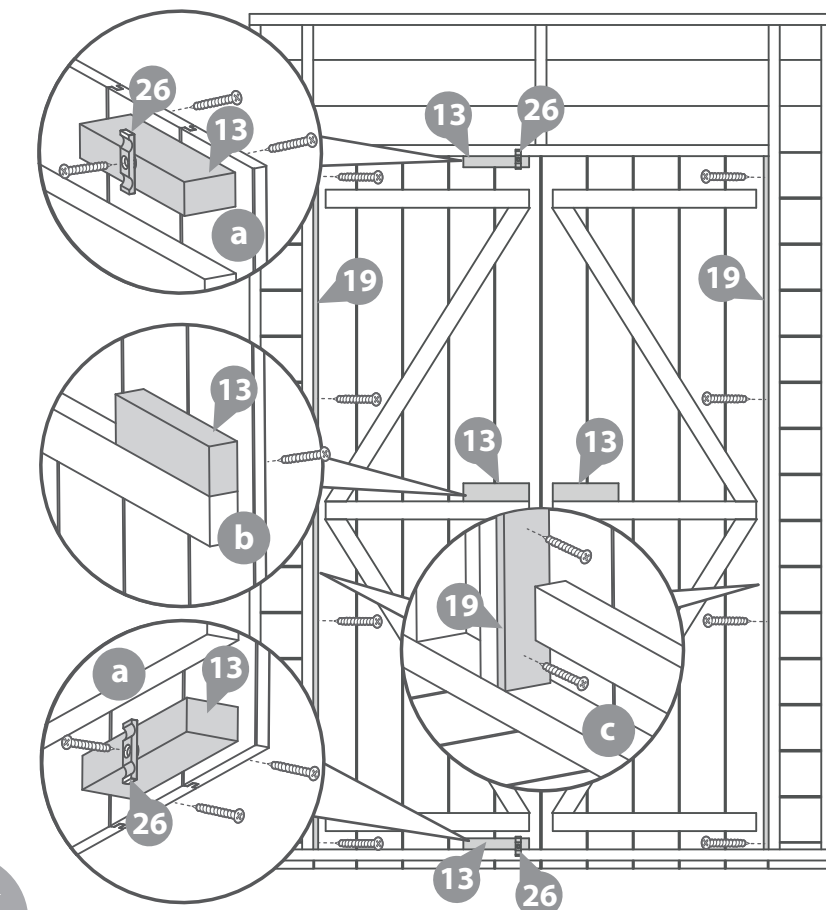

Step 19

Parts needed- No.32 QTY 1
No.33 QTY 1

Cut the Felt (No.32) and the Capping Felt (No.33) in to sheets at 3650mm each. Lay onto roof as shown in diagram ensuring there is a 50mm overhang around the sides.

Apply the felt tacks with a 100mm space per tack.

146xFelt tacks

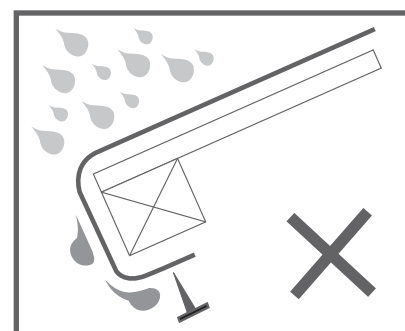
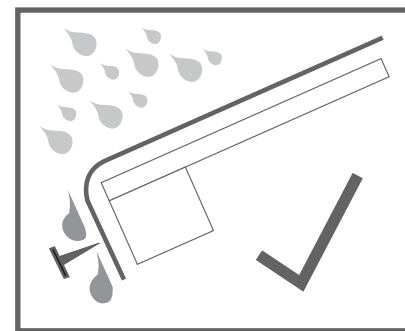
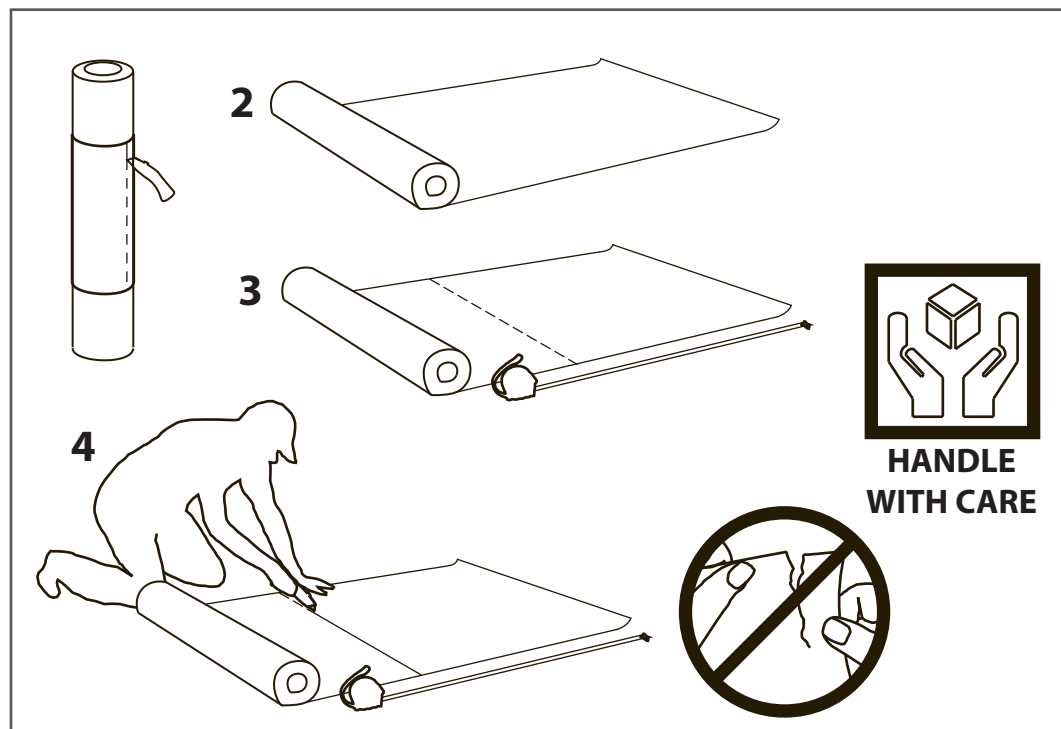
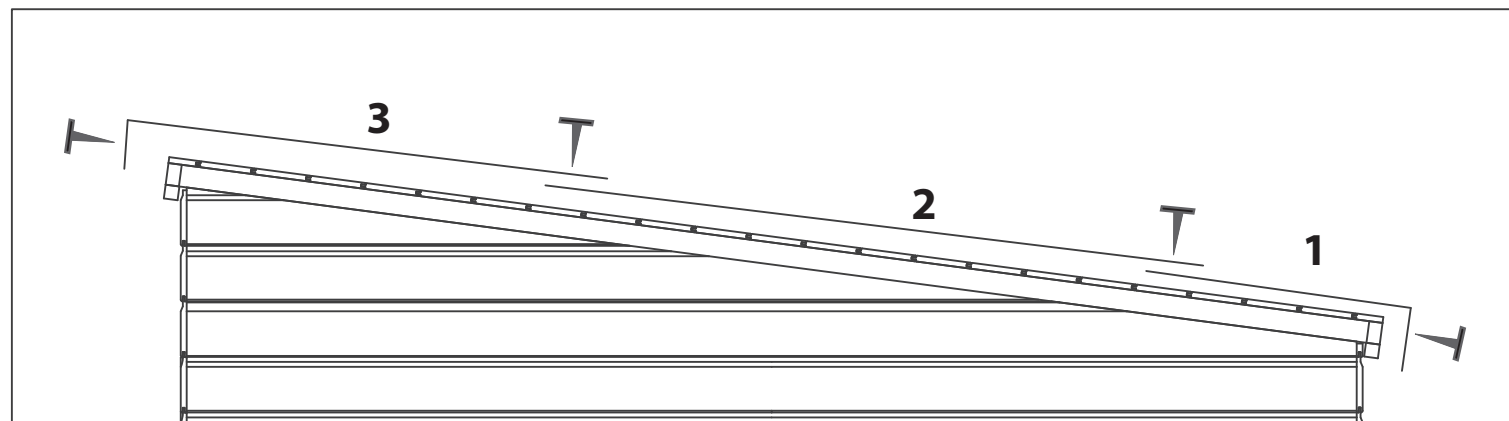
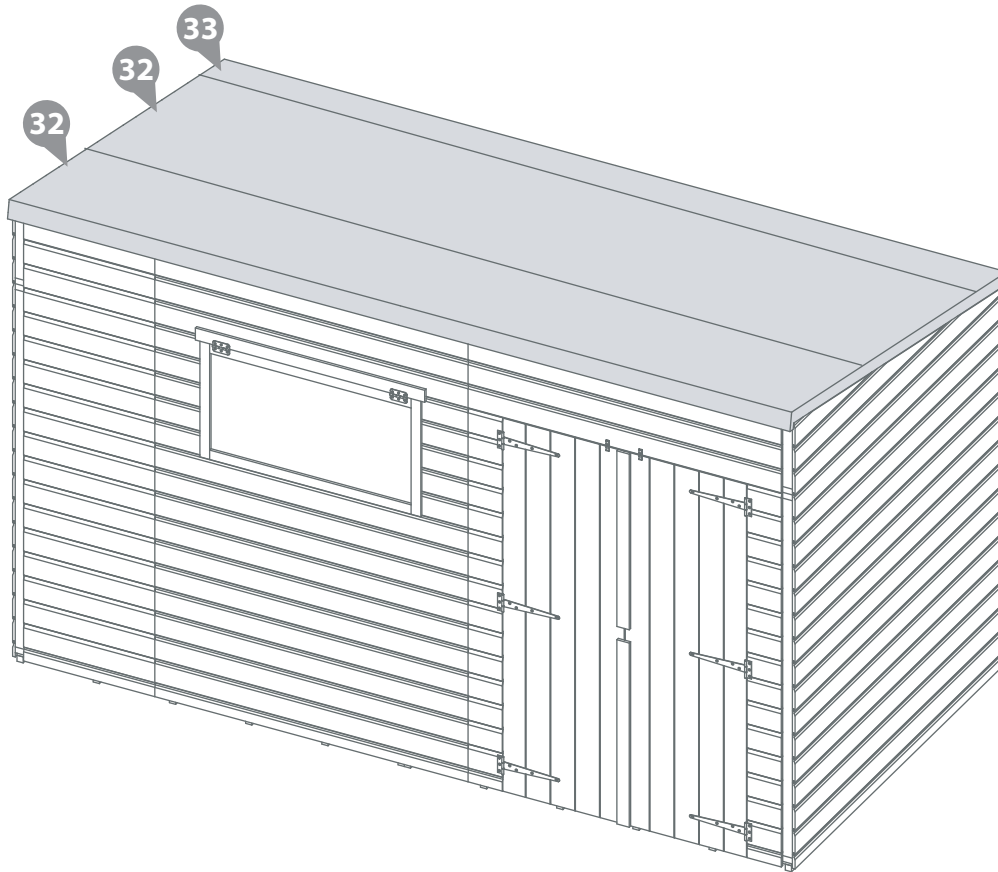

Step 20

Parts needed- No.30 QTY 1

Align the lock (No.30) to the door, ensuring equal spacing between the cover trims and across the doors.

Measure and mark the holes of the lock (No.30) and drill through the boards and through the framing and door blocks

Fix the lock onto the door using 8x60mm Carriage Bolts and Nuts

8x60mm Carriage Bolts and Nuts

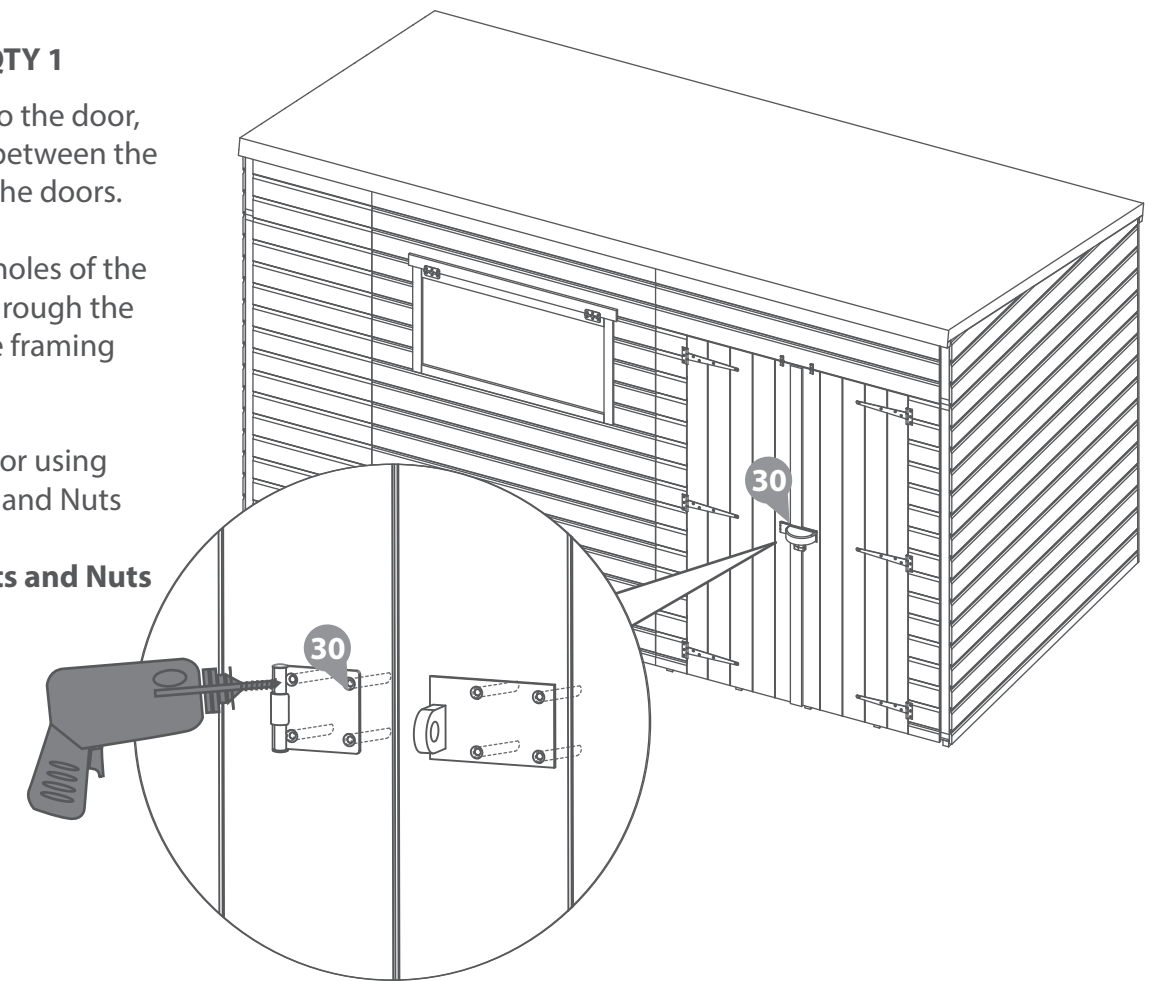

Step 21

Parts needed -No.20 QTY 4
-No.21 QTY 4

Fix the Cover trims (No.20 & No.21) to the corners and across each join of the building as shown, secure to the building using 3x30mm screws per cover trim.

24x30mm Screws

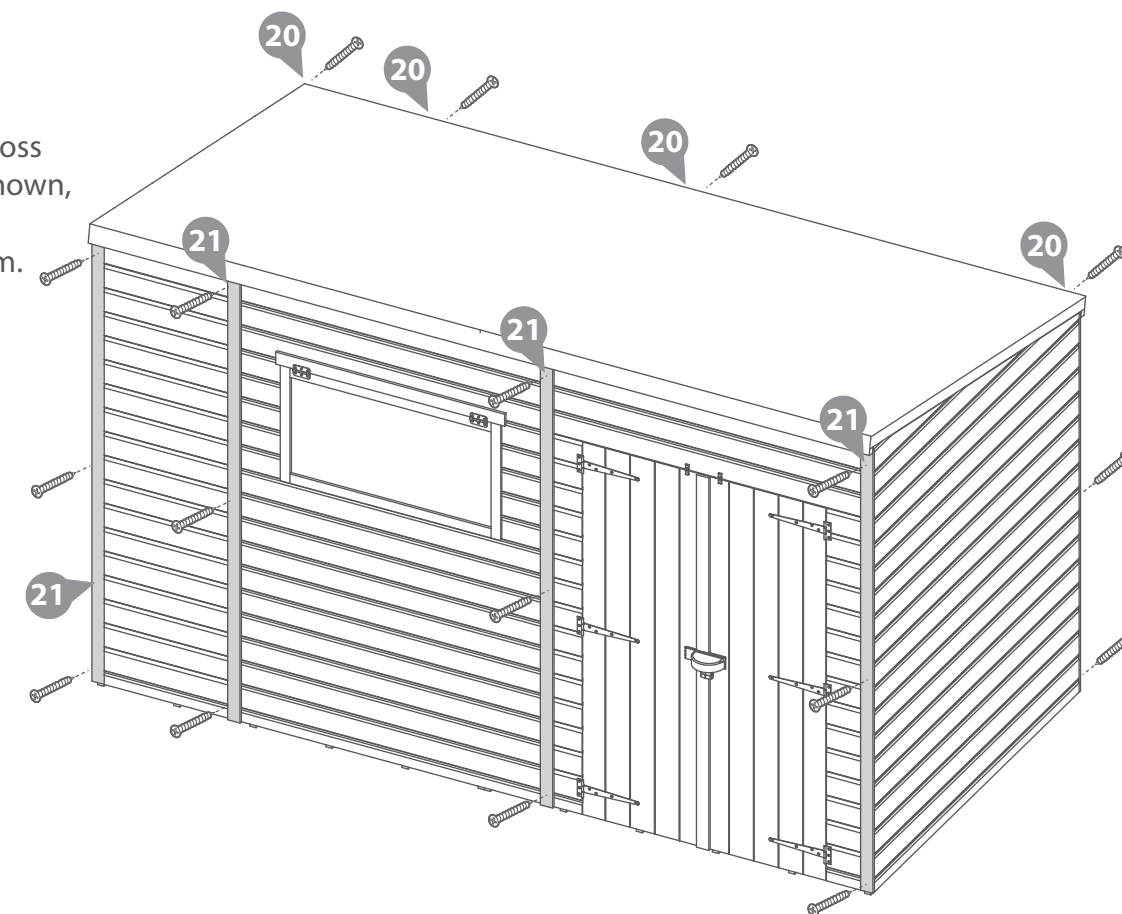

Step 22

Parts needed- No.22 QTY 4
-No.23 QTY 2

Fix the Fascias (No.22 and No.23)
to each side of the building,
ensuring they are flush to the top
of the building, secure using
3x40mm screws per fascia.

18x40mm Screws



40mm
screw

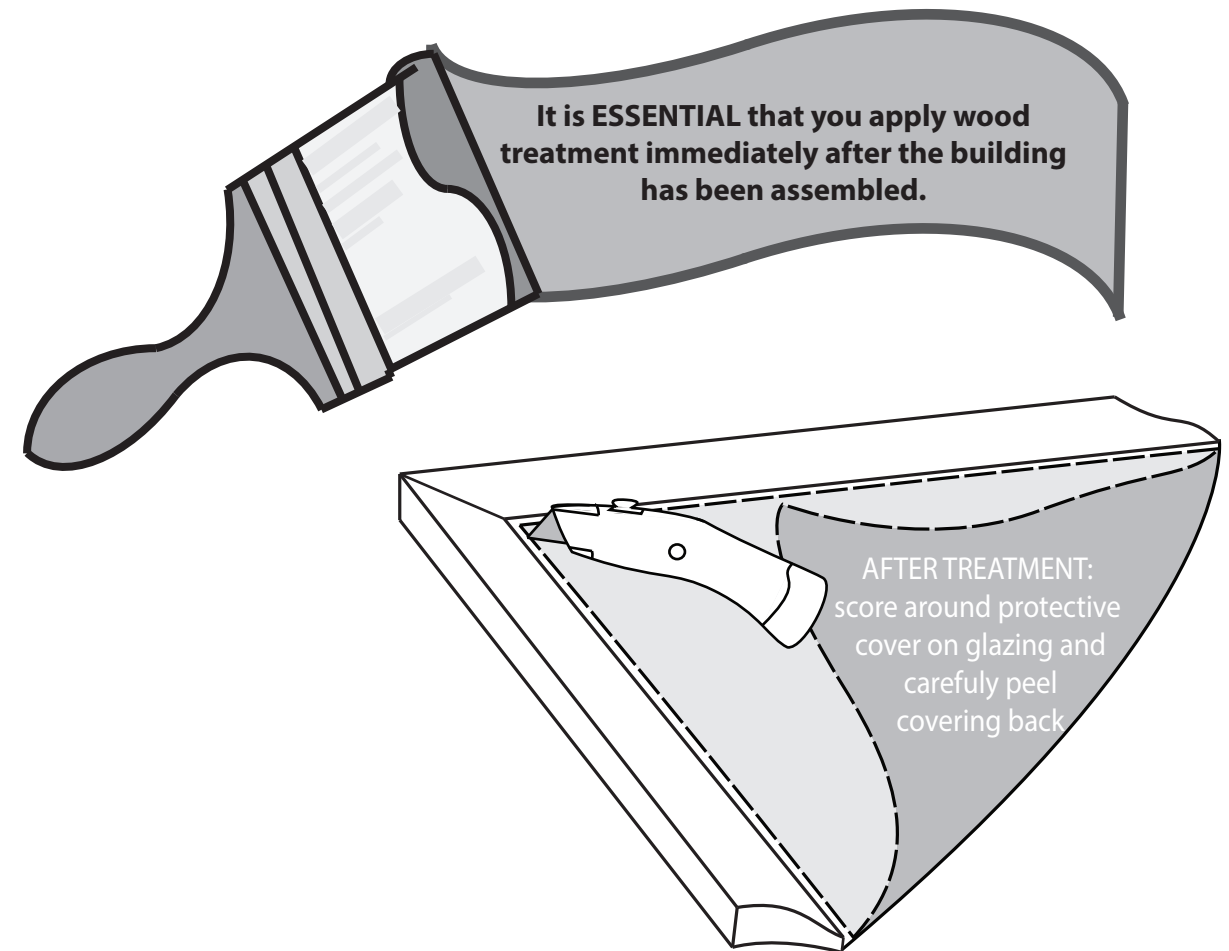
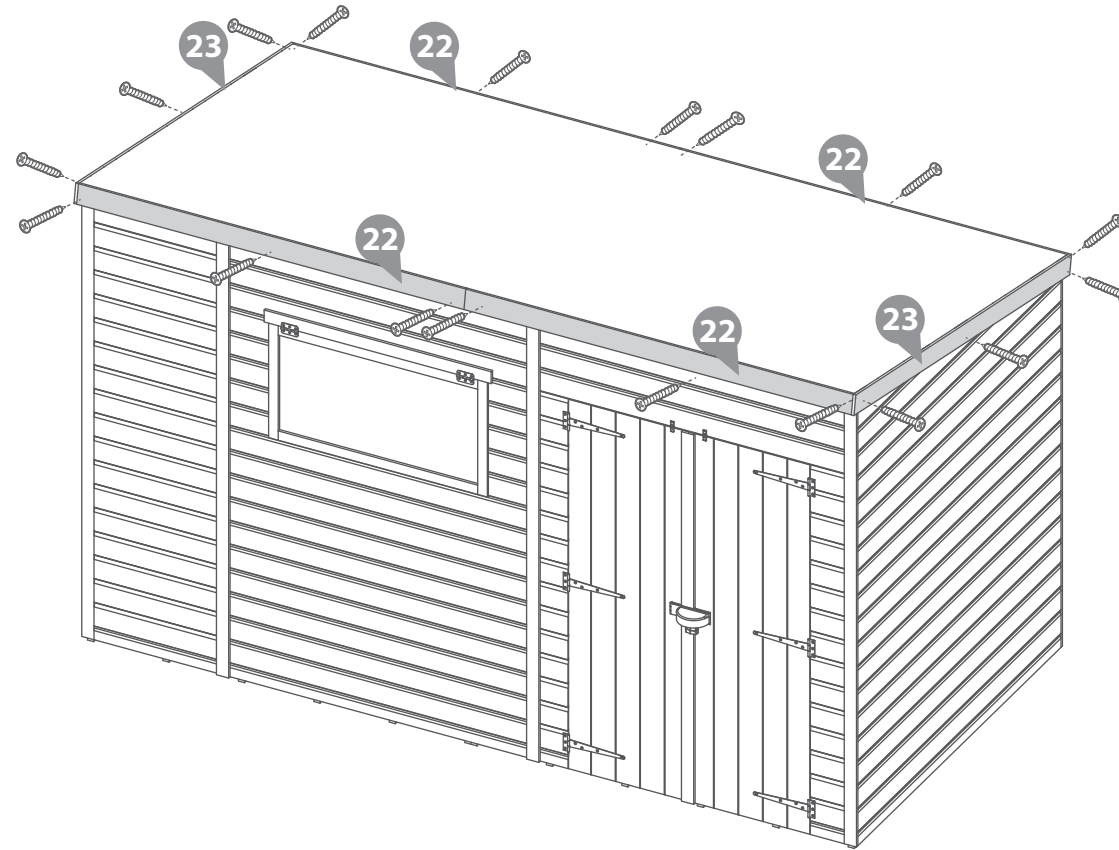

All our garden buildings have been designed and manufactured with care and attention to be the perfect addition to your outdoor space. To ensure you do get the best out of your new garden building and to increase the longevity we advise that you follow the product instructions and our manufacturer's recommendations as detailed below. Thank you for choosing a Mercia Garden product!

1 Choosing the most suitable location for your garden building...

A minimum of 60cm should be left around the perimeter of your garden building to allow access for maintenance, annual treatment and to allow air flow around the building.

Where possible you should avoid placing your garden building underneath large trees to prevent the tree causing damage to the building.

2 Preparing the base for your garden building...

All our buildings must be built on a firm, level base to ensure the longevity of the building and prevent the wood from distorting. We recommend either concrete, concrete slabs or a wooden base, such as our 'Portabase'.

The base should be slightly smaller than the external measurement of the building, i.e. the cladding should overlap the base, creating a run off for water and preventing water from pooling underneath the building.

We also recommend that the floor of the garden building is a minimum of 25mm above the surrounding ground level to avoid flooding.

3 After installation...

Once your garden building has been installed it will need to be treated as soon as possible and annually to prevent the timber from deteriorating and to waterproof it. This is required to maintain the anti-rot guarantee.

Dip Treated buildings - Require a preservative treatment to protect against rot and decay and a waterproof treatment to prevent water ingress

Pressure Treated buildings - Require a waterproof treatment to prevent water ingress

Log Cabins/Insulated Garden Rooms - Are supplied untreated and require a preservative and waterproofing treatment

We also recommend using a silicon sealant on the inside and outside of the windows as soon as possible after assembly and treatment to fully seal the windows.

Roofing felt/covering should be checked annually and replaced or fixed accordingly.

4 General maintenance and wood characteristics

As wood is a natural material it may be affected by the following:

Shrinkage and warping - The timber used in the construction of your garden building will have retained some of its natural moisture content. The moisture content of the timber will vary, depending upon prevailing environmental conditions, which will result in the components either naturally expanding or contracting. As the components dry out shrinkage may occur. A good waterproofing treatment from the start is the best protection to minimise the effect of moisture loss/intake.

In extended periods of very warm weather getting some moisture to the building will help the overall balance. You can do this by spraying it down lightly with a garden hose. In contrast after snow fall try to remove the snow as best as possible from the roof to prevent moisture intake and to remove the extra weight.

Top tip - using a garden brush will help you to reach the highest part of the building to remove snow and any debris left from bad weather.

Damp and mould - During the winter months, cold and damp conditions can result in an increased amount of moisture within your garden building, especially when used infrequently. Condensation can form on the timber and other items stored within your garden building. If left this moisture is likely to cause mould and mildew. To prevent the build-up of moisture, we recommend leaving the door or windows of your building open from time to time, to allow the fresh air to circulate. We also advise against storing wet or damp items in your garden building as this will also increase the level of moisture in the building. If mould or mildew does start to form within your building we recommend using an anti-mould cleaner to remove it and to prevent it spreading, which if left untreated could permanently damage your garden building.

Splits, cracks and knots - You may notice small splits and cracks in some components or holes may appear where knots shrink and fall out. This will not affect the structure of your Garden building however if you wish to fill them this can be easily done using any good quality wood filler.

Sap - is naturally occurring in wood and may appear in some boards of your garden building. If you wish to remove the sap, we advise waiting until it is dry and then using a sharp knife to carefully remove it. If the removal of the sap causes a hole in the timber, we recommend using a good quality wood filler to fill it.

For more handy hints and tips on how to care and maintain your garden building please refer to the MGP Customer Portal at www.mgplogistics.co.uk

Any further questions?

Contact our
Customer Service
Team on:
01636 821215

1 Manufacturer's Warranty

All Mercia Garden Products are supplied with a 1 year warranty on all parts against manufacturing defects.
This warranty does not cover movement, warping or splitting of timber products over time.

This warranty will be voided if any of the following occur:

1. The building has been customised or modified/adapted in any way.
2. The person claiming is not the original purchaser of the building.
3. Any damage has been caused by or as a result of misuse.
4. The building has not been maintained and cared for in accordance to our advisories and manufacturer's recommendations.
5. The building has not been treated annually or as per the manufacturer's recommendations, please ensure receipts are kept to validate this claim.
6. The building has not been erected, fitted or installed as per the supplier instructions.
7. The building has not been erected on a suitable sized firm flat, solid level concrete/slab base or placed on pressure treated bearers.
8. The building is or has been placed with 2 feet (60cm) of any obstructions (walls, trees, plants, fences etc.) which can allow moisture to penetrate the timber.
9. The roofing felt has been incorrectly fitted or damaged allowing water ingress, or not properly maintained.
10. Any windows and joints have not been sealed, inside and out, with silicone or other watertight sealant.
11. Any timber has been cut, pierced or drilled without subsequent application of approved cut-end treatment.

2 Anti-rot Guarantee

Mercia Garden Products offer a 10 year anti-rot guarantee on all dip treated (a preparatory treatment) and 15 years on all pressure treated products. This guarantee covers solid timber against rot, decay, blue stain and insect attack.

To validate the guarantee the building must be treated with a recognised wood preserver/water proof top coat (as detailed within manufacturer's recommendations) as soon as possible after assembly and annually thereafter.

This guarantee does not cover movement, warping or splitting of timber products over time.

This guarantee will be voided if any of the following occur:

1. The building has been customised or modified/adapted in any way.
2. The person claiming is not the original purchaser of the building.
3. Any damage is caused by or as a result of misuse.
4. The building has not been maintained and cared for in accordance to our advisories and manufacturer's recommendations.
5. The building has not been treated annually or as per the manufacturer's recommendations, please ensure receipts are kept to validate this claim.
6. The building has not been erected, fitted or installed as per the supplier instructions.
7. The building has not been erected on a suitable sized firm flat, solid level concrete/slab base or placed on pressure treated bearers.
8. The building is or has been placed with 2 feet (60cm) of any obstructions (walls, trees, plants, fences etc.) which can allow moisture to penetrate the timber.
9. The roofing felt has been incorrectly fitted or damaged allowing water ingress, or not properly maintained.
10. Any windows and joints have not been sealed, inside and out, with silicone or other watertight sealant.
11. Any timber has been cut, pierced or drilled without subsequent application of approved cut-end treatment.



REGISTER FOR YOUR
ANTI-ROT
GUARANTEE TODAY

PLEASE SCAN HERE:

