

General Instructions

Please retain product label and instructions for future reference

01DTSHRAX0604SDFW-V1

DIP TREATED SHIPLAP REVERSE APEX 6X4 SINGLE DOOR FIXED WINDOW

BEFORE YOU START PLEASE READ INSTRUCTIONS CAREFULLY

- Check the pack and make sure you have all the parts listed.
- When you are ready to start, make sure you have the right tools at hand (not supplied) including a Phillips screwdriver, Stanley knife, Wood saw, Step ladder, Hammer and a Drill with 2mm bit.
- Ensure there is plenty of space and a clean dry area for assembly.

LOCATION FOR YOUR GARDEN BUILDING

A minimum of 60cm should be left around the perimeter of your garden building to allow access for maintenance, annual treatment and to allow air flow around the building.

Where possible you should avoid placing your garden building underneath large trees to prevent the tree causing damage to the building.

TIMBER

As with all natural materials, timber can be affected during various weather conditions. For the duration of heavy or extended periods of rain, swelling of the wood panels may occur. Warping of the wood may also occur during excessive dry spells due to an interior moisture loss. Unfortunately, these processes cannot be avoided but can be helped. It is suggested that the outdoor building is sprayed with water during extended periods of warm sunshine and sheltered as much as possible during rain or snow.

Once your garden building has been installed it will need to be treated as soon as possible and annually to prevent the timber from deteriorating and to waterproof it. This is required to maintain the anti-rot guarantee.

Dip Treated buildings - Require a preservative treatment to protect against rot and decay and a waterproof treatment to prevent water ingress

Pressure Treated buildings - Require a waterproof treatment to prevent water ingress

Log Cabins - Are supplied untreated and require a preservative and waterproofing treatment.

BUILDING A BASE

When thinking about where the building and base is going to be constructed: Ensure that there will be access to all sides for maintenance work and annual treatment.

Ensure the base is level and is built on firm ground, to prevent distortion. Refer to diagrams for the base dimensions, The base should be slightly smaller than the external measurement of the building, i.e. The cladding should overlap the base, creating a run off for water. It is also recommended that the floor be at least 25mm above the surrounding ground level to avoid flooding.

TYPES OF BASE

- Concrete 75mm laid on top of 75mm hard-core.
- Slabs laid on 50mm of sharp sand.

Whilst all products manufactured are made to the highest standards of Safety and in the case of childrens products independently tested to EN71 level, we cannot accept responsibility for your safety whilst erecting or using this product.



x2

All buildings should be erected by two adults



Winter = High Moisture = Expansion
Summer = Low Moisture = Contraction



2mm Drill bit

For ease of assembly, you **MUST** pilot drill all screw holes and ensure all screw heads are countersunk.



CAUTION

Every effort has been made during the manufacturing process to eliminate the prospect of splinters on rough surfaces of the timber. You are strongly advised to wear gloves when working with or handling rough sawn timber.



For ease of assembly, you will need a tape measure to check dimensions of components.

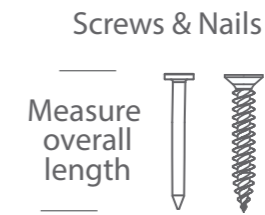

Measure overall length

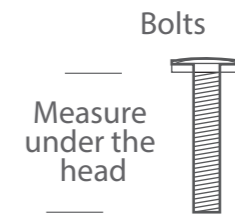

Measure under the head

To identify the fixings required for each step use a measuring tape.

****Protim Aquatan T5 (621)****

Your building has been dip treated with **Aquatan**.

Aquatan is a water-based concentrate which is diluted with water, the building as been treated by the correct application of Aquatan solution and then allowed to dry.

Aquatan is a decorative finish to colour the wood, which is applied industrially to timber fence panels and garden buildings.

Aquatan undiluted contains: boric acid, sodium hydroxide 32% solution, aqueous mixture of sodium dioctyl sulphosuccinat and alcohols: 2, 4, 6-trichlorophenol.



REGISTER FOR YOUR
ANTI-ROT
GUARANTEE TODAY

PLEASE SCAN HERE:



For assistance please contact customer care on: 01636 821215

Mercia Garden Products Limited,

Sutton On Trent,

Newark,

Nottinghamshire,

NG23 6QN

www.merciagardenproducts.co.uk



Overall Dimensions:

Width = 1313mm
 Depth = 1838mm
 Height = 2159mm

Base Dimensions:

Width = 1175mm
 Depth = 1753mm

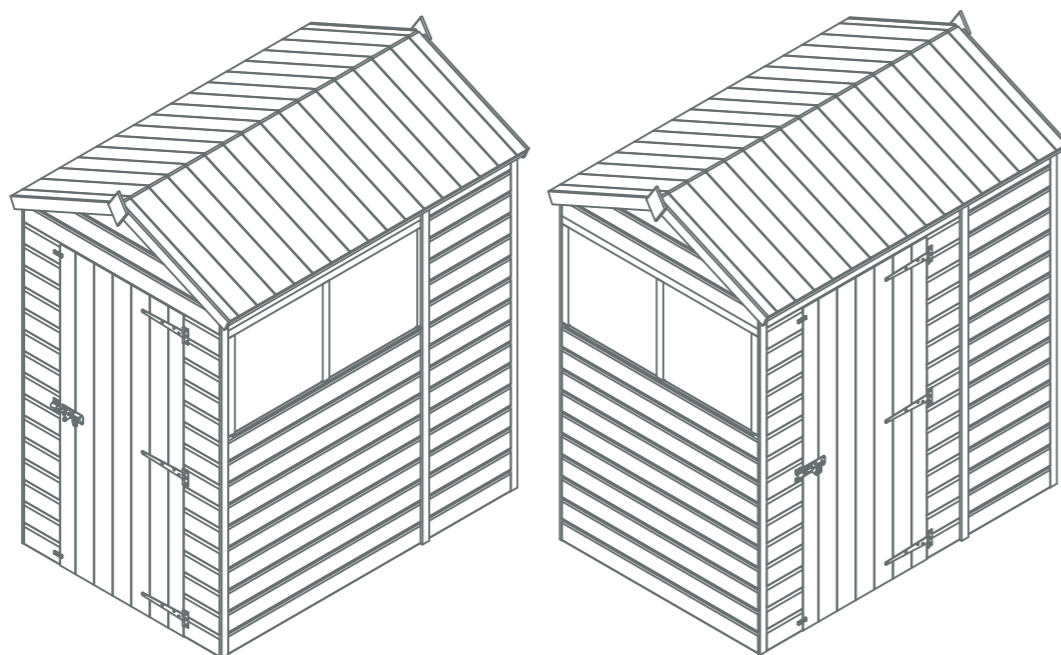

The building that you have purchased can be built as an Apex or a Reverse Apex. Also you can choose in which arrangement you wish to have your panels set up. See these images on display to give you an idea of which set up is most suitable for you.

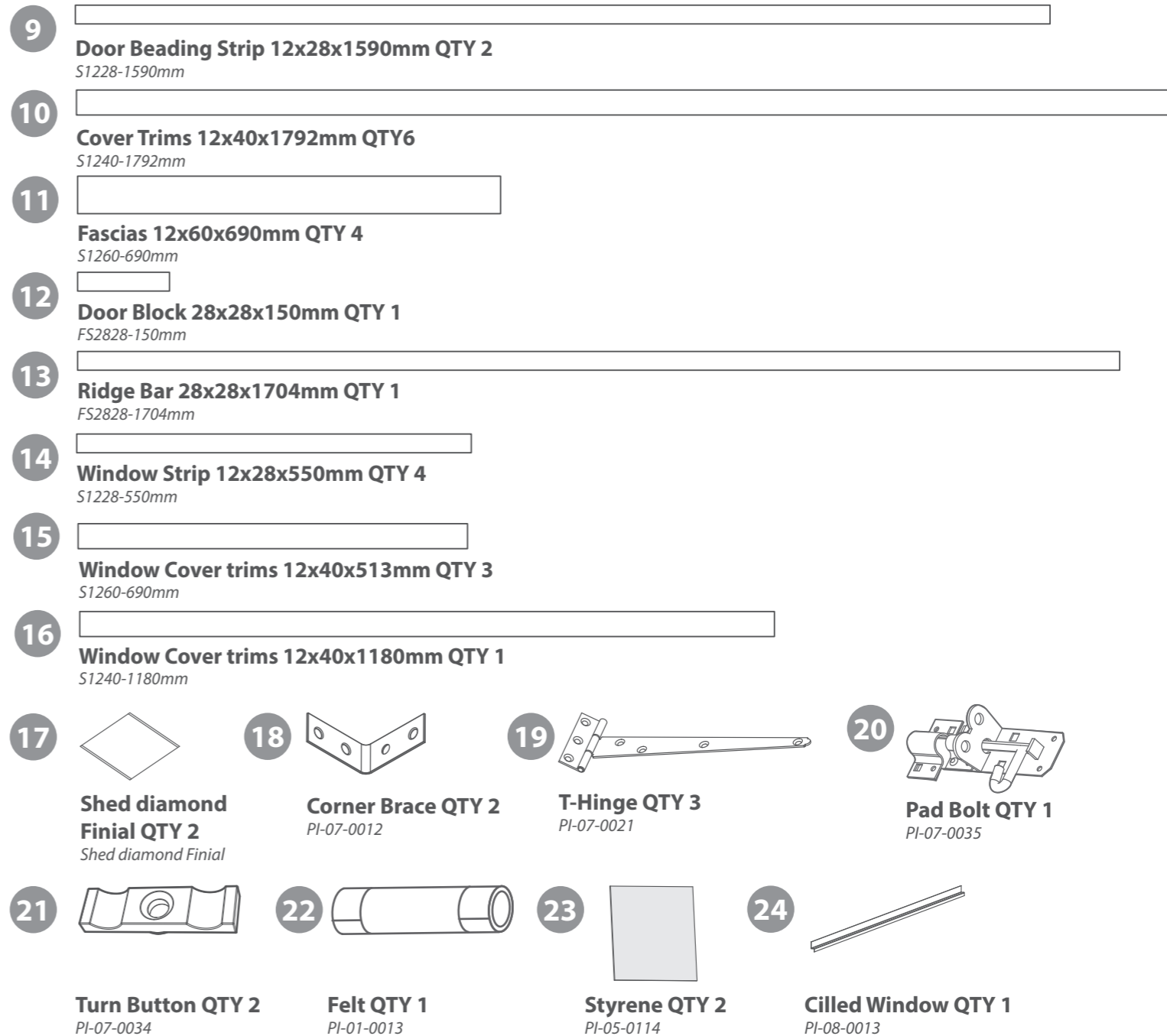
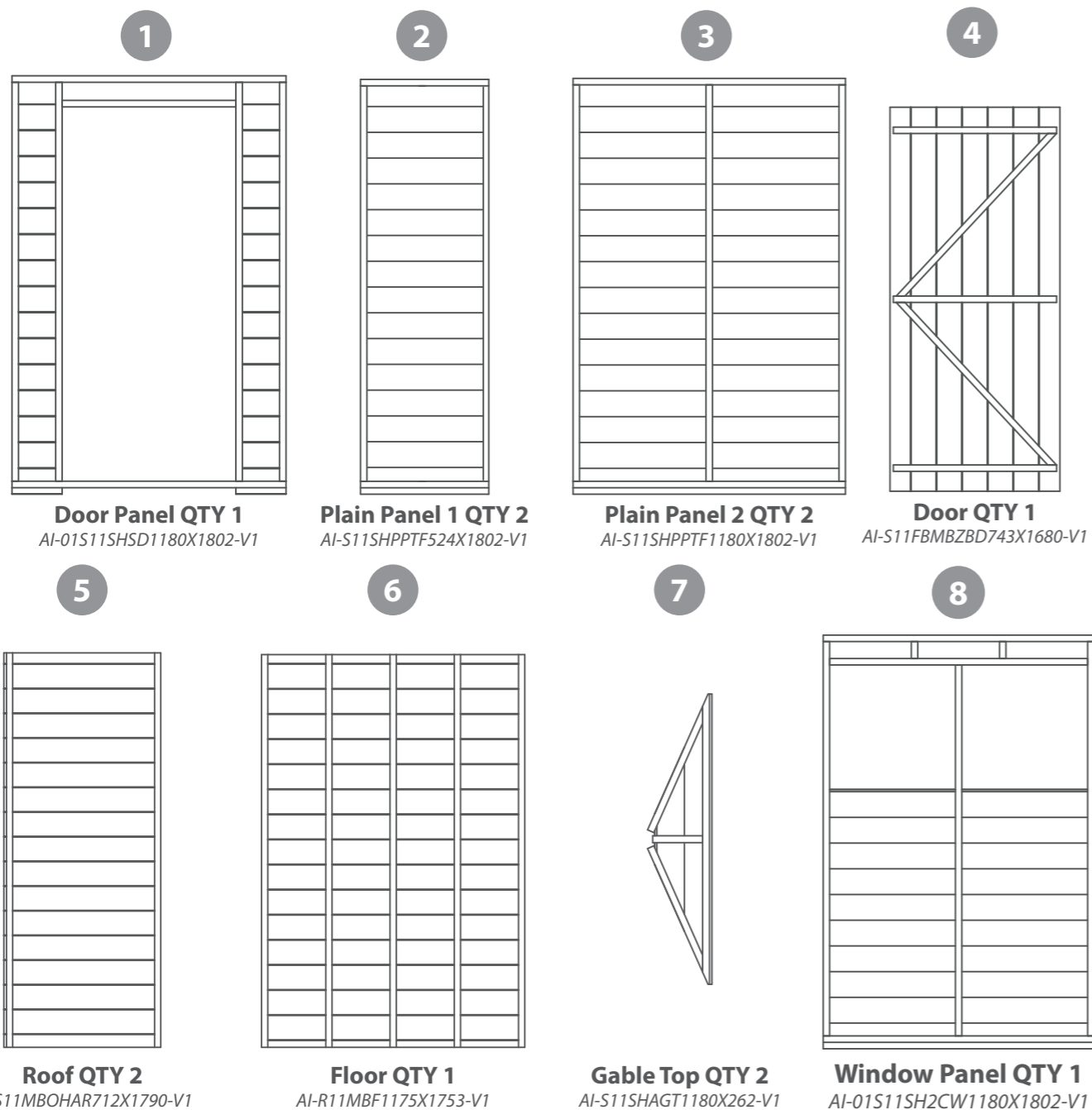

Nail Bag

There may be extra screws present in the nail bag

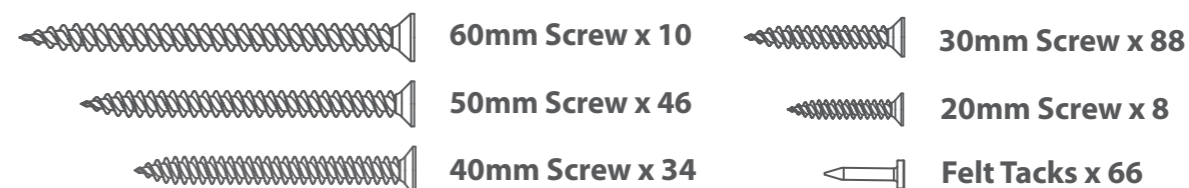

Pre Assembly

Before assembling remove the transportation blocks from the bottom of each panel.

Take care removing the blocks as to not damage the panels. Tap with a flat headed screwdriver and hammer.

Dispose of the blocks once removed.

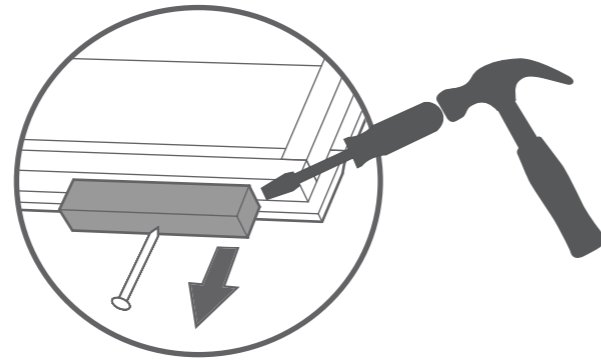

Step 2

Parts needed - No. 1 QTY 1
No. 4 QTY 1
No. 19 QTY 3

Place the door (No. 4) within the Door Panel (No. 1). Fix the T Hinges (No. 19) onto the door and Door Panel as shown (taking into account on which side of the Door Panel opening you want the Door to open). Ensure that the screws go through the cladding and into the framing behind.

21x30mm Screws



****PLEASE NOTE**** Before fitting the hinges, ensure the door is in the correct position depending on which side you want the door to open. See external illustrations below which show the doors internal framing.

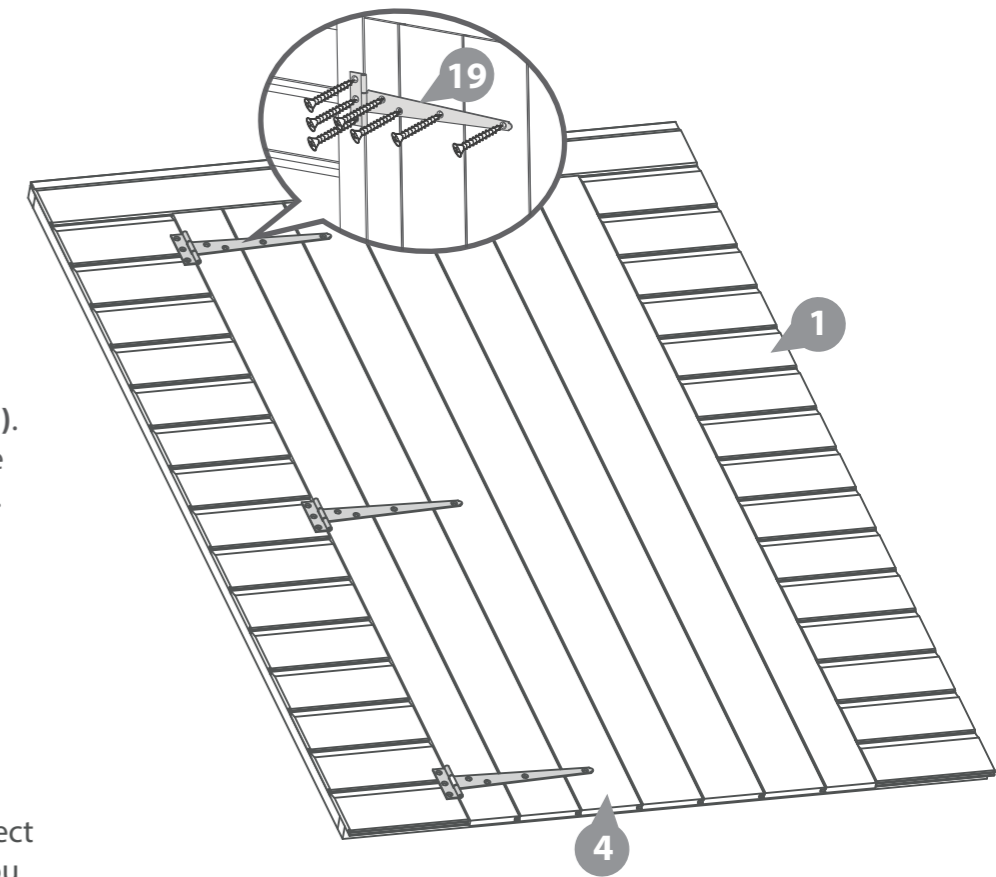

Step 1

Parts needed - No. 6 QTY 1

Place the floor panel (No. 6) onto a firm and level base. Ensure the base has suitable drainage, free from areas where standing water can collect. See front page for base requirements.

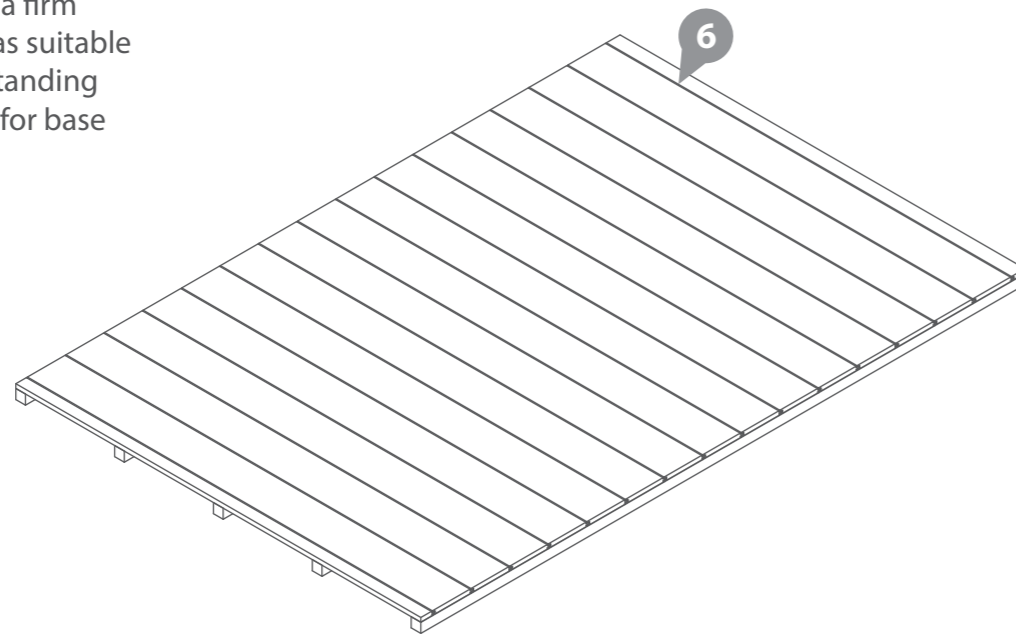

Opens from the Left

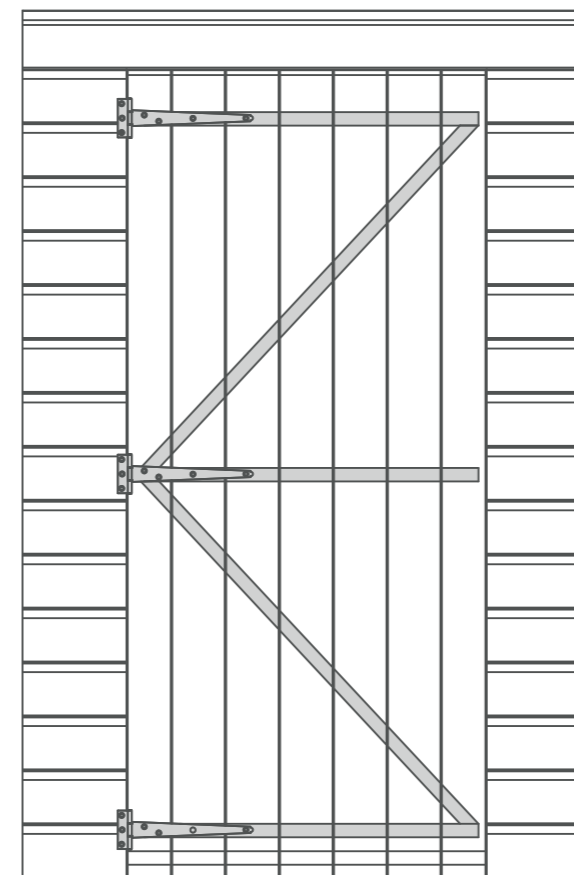

Opens from the Right

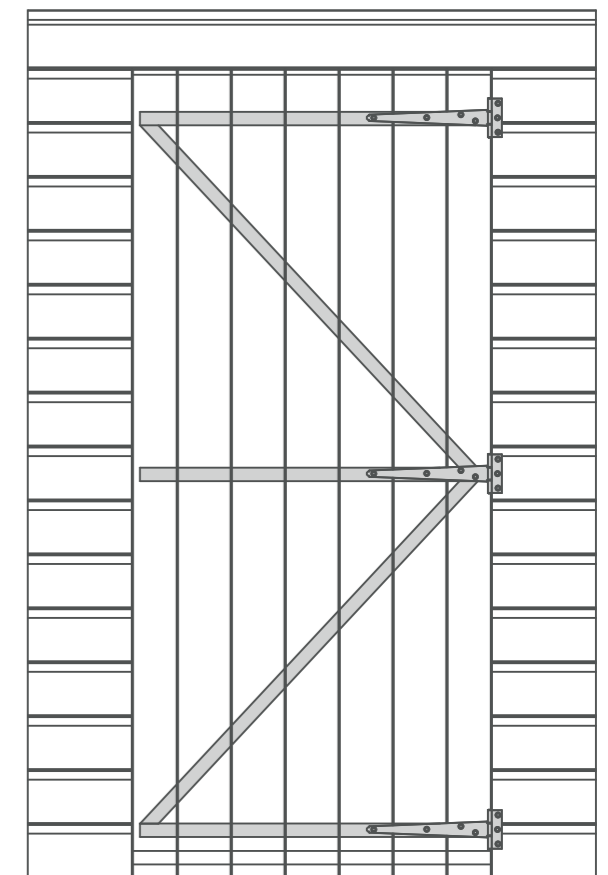

Step 3

Parts needed - No. 2, (or 1, or 3, or 8) QTY 1
No. 3 (or 8) QTY 1

****Please note: The side panels are all interchangeable and can be positioned in a variety of configurations. Decide which works best before assembly. See Page 2 for suggested options.****

Fix the corners of the Plain panel 2 (No. 2) and a Plain Panel 1 (No. 2) (or panel of your choice) with 50mm screws as shown in diagram.

Do not secure the building to the floor until the roof has been fitted,

Position the panels so there is equal spacing between the floor and cladding on all sides.

3x50mm Screws

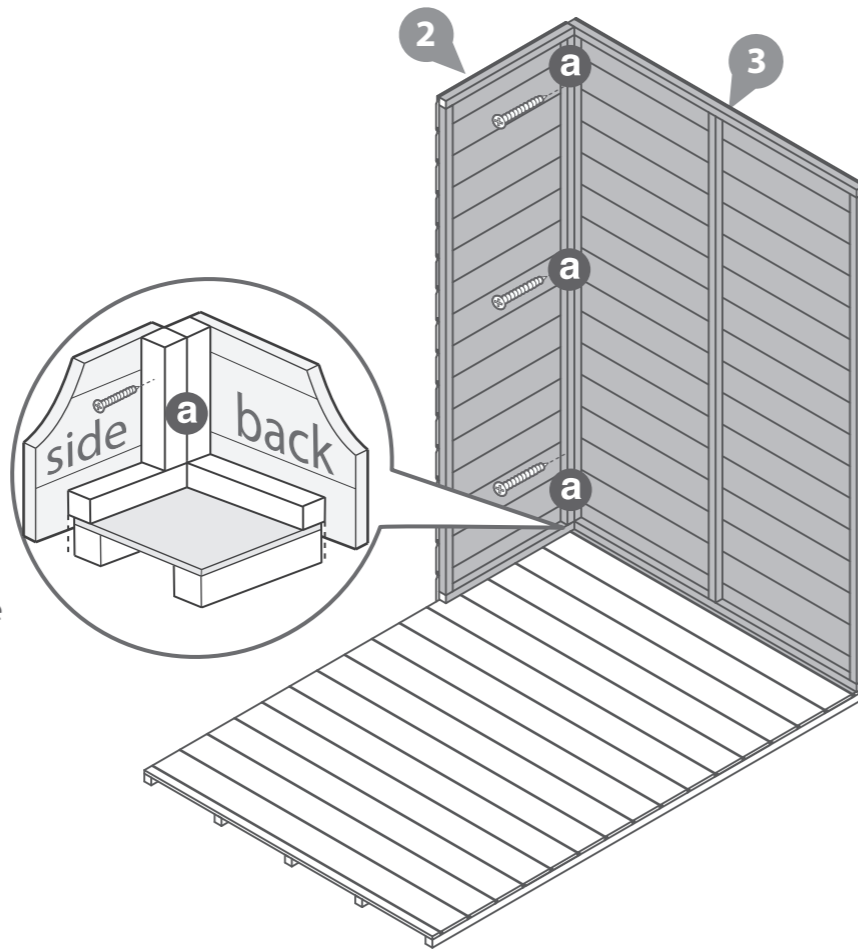
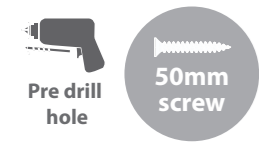

Step 5

Parts needed - No. 8 QTY 1

Fix the end of the Window Panel (No. 8) (or panel of your choice) to the already standing chosen panel with 50mm screws as shown in diagram.

Do not secure the building to the floor until the roof has been fitted,

Position the panels so there is equal spacing between the floor and cladding on all sides.

3x50mm Screws

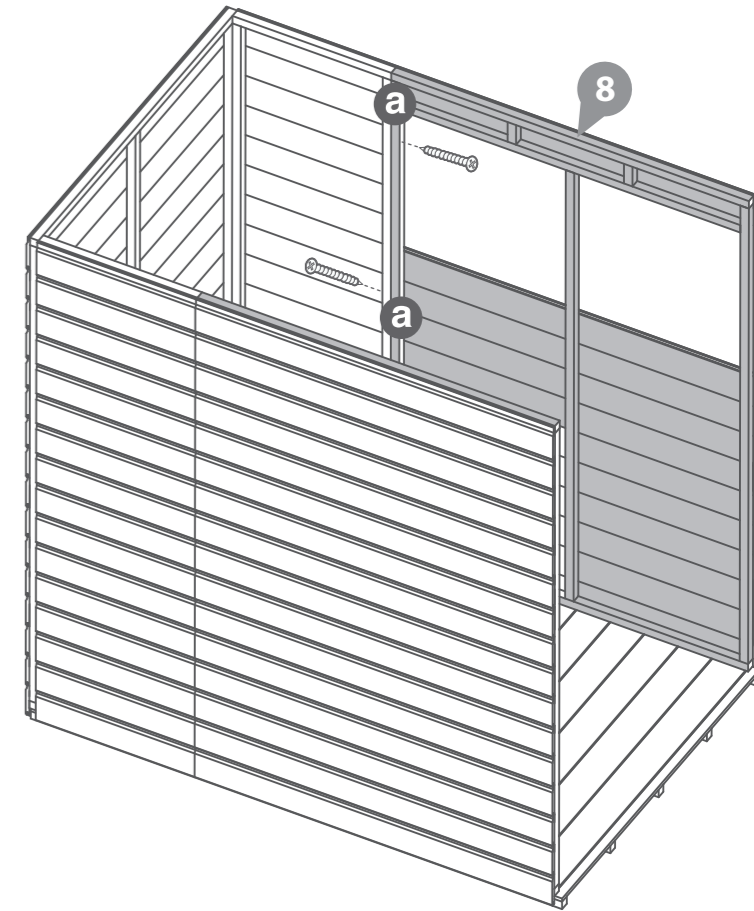
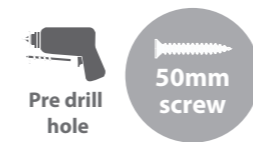

Step 4

Parts needed - No. 2, (or 1, or 3, or 8) QTY 1
No. 3, (or 1, or 8) QTY 1

Fix the corners of the Plain panel 1 (No. 2) (or panel of your choice) and the Plain panel 2 with 50mm screws as shown in diagram.

Fix the end of the Plain Panel 2 (No. 3) (or panel of your choice) to the already standing chosen panel with 50mm screws as shown in diagram.

Do not secure the building to the floor until the roof has been fitted,

Position the panels so there is equal spacing between the floor and cladding on all sides.

6x50mm Screws

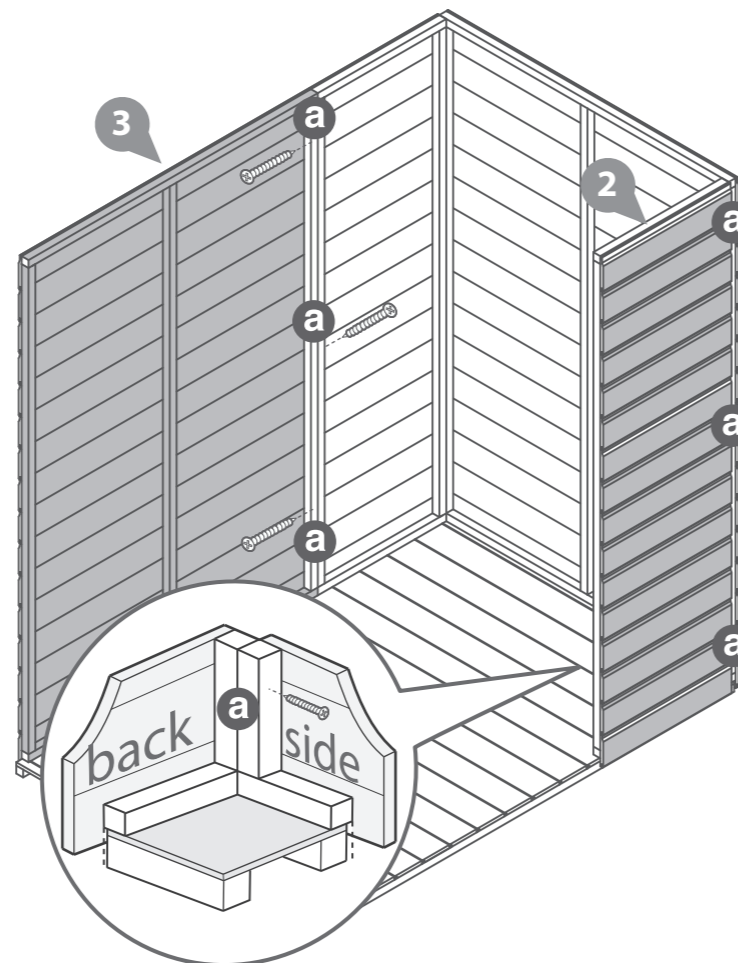
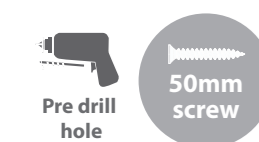

Step 6

Parts needed - No. 1, (or 3, or 8) QTY 1

Fix the corners of the Door Panel (No. 1) (or panel of your choice) to the plain panels (No. 2 or 3) with 50mm screws as shown in diagram.

Do not secure the building to the floor until the roof has been fitted,

Position the panels so there is equal spacing between the floor and cladding on all sides.

6x50mm Screws

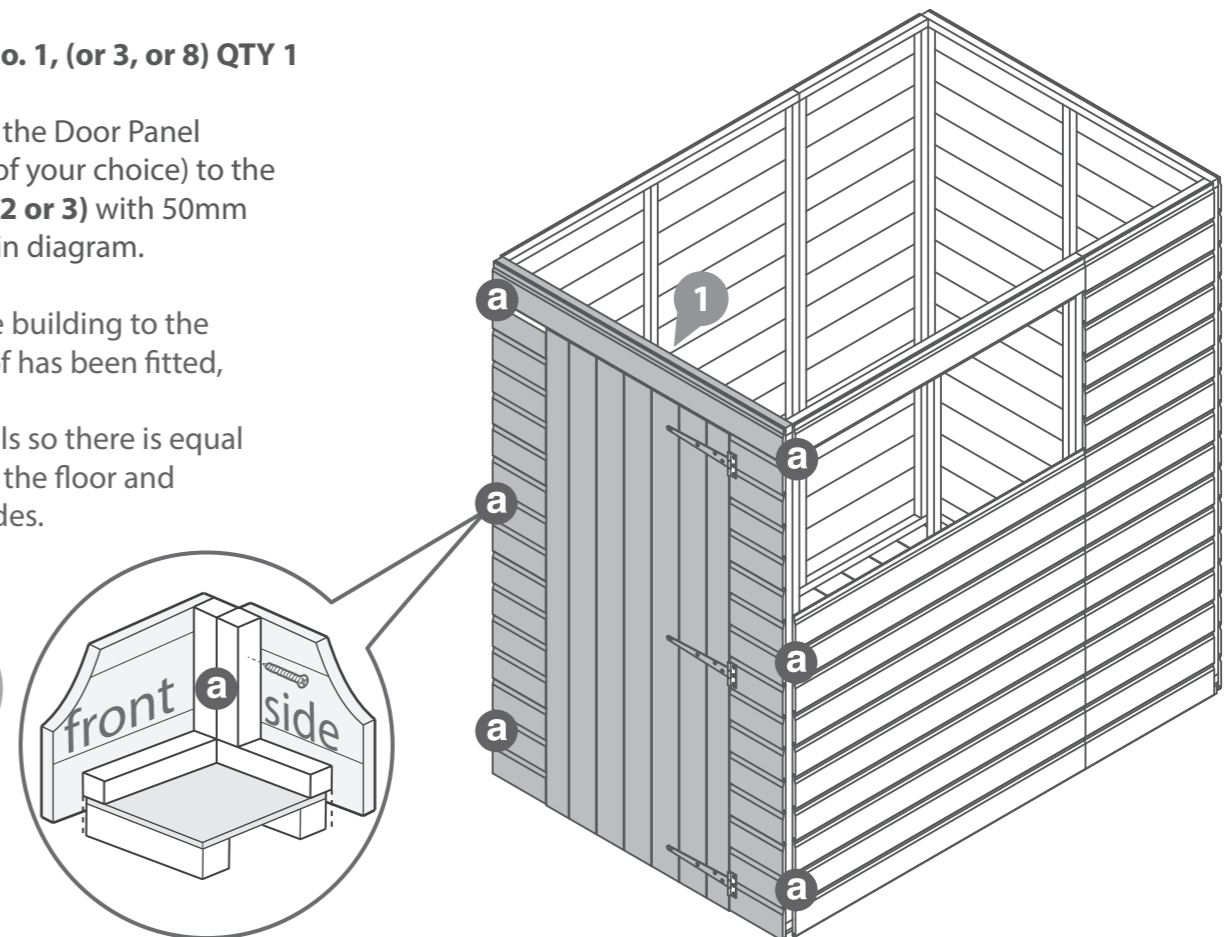

Step 7

Parts needed - No. 7 QTY 2

Place the Gable Tops (No. 7) central over the end panels. Make sure that the cladding slots together and fix into position using 50mm screws.

Fix together using 8x50mm screws staggering the screws so they don't collide.

8x50mm Screws

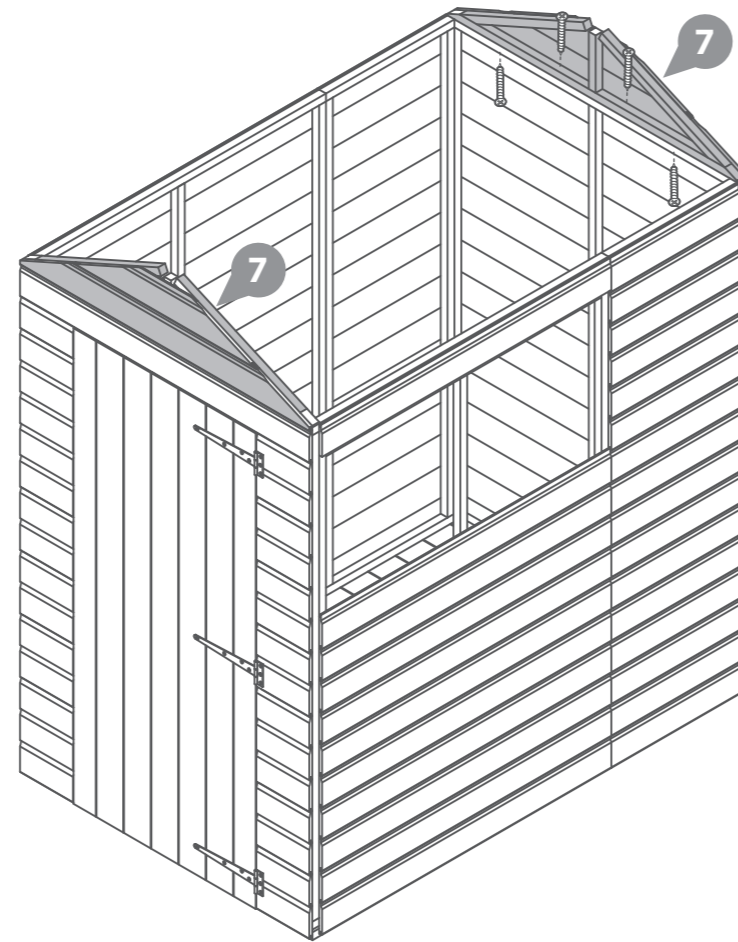
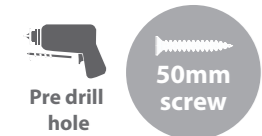

Step 8

Parts needed - No. 13 QTY 1
No. 18 QTY 2

Place the ridge bar (No. 13) in between the Gable Tops (No. 7) in line with the central framing of the gable tops.

Fix the ridge bar to the gable using one L bracket (No. 18) for each end. Fix with 4x20mm screws each.

8x20mm Screws

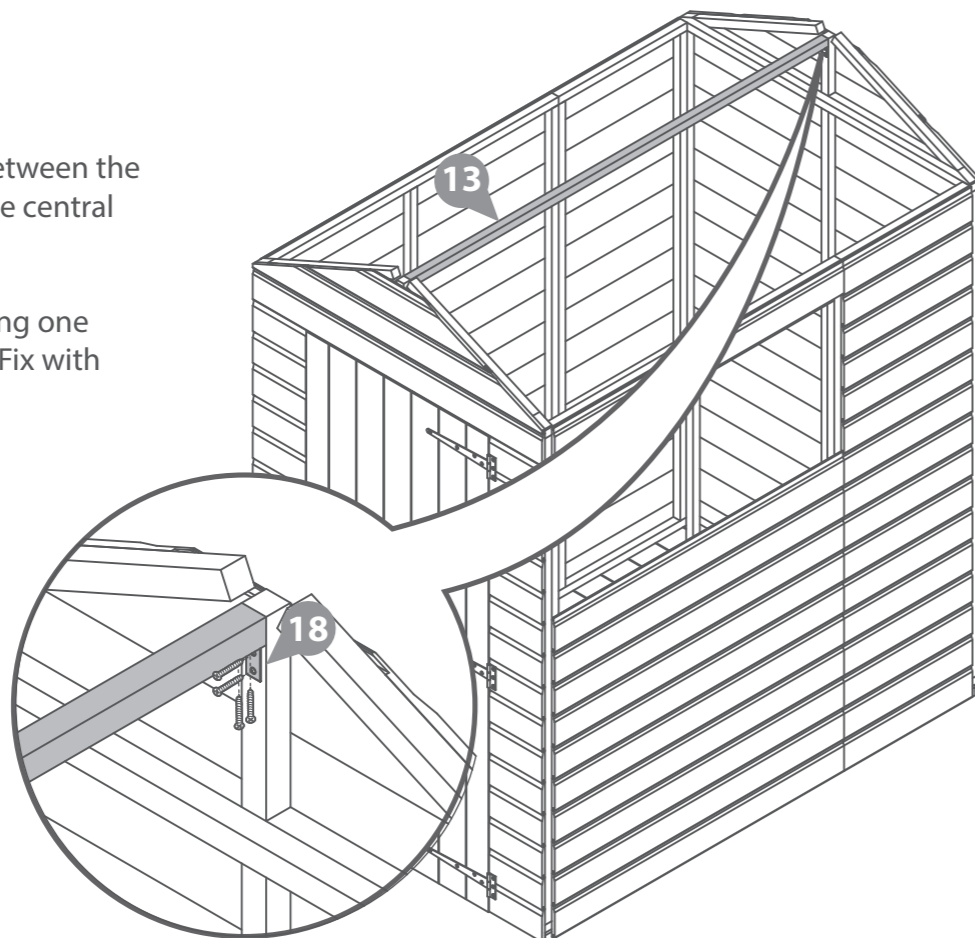

Step 9

Parts needed - No. 5 QTY 2

Place the Roof Panels (No. 5) on top of the building making sure the framing in the roof panels sits firmly within the Gable Tops (No. 7) and on top of the Ridge Bar (No. 13).

****Make sure that you have got the roof panels the correct way round with the recess at the top of the apex as shown in the diagram.****

****The edges of the roof panels must be flush with the outer cladding of the Gable Tops (No. 7).****

From the top, fix directly through the roof panels (No. 5) and into the ridge bar (No. 13) below using 5x60mm screws per roof panel.

It is essential that the ridge bar (No. 13) and roof panel (No. 5) framing pull together when fixed with 60mm screws. You may require another person pushing the ridge bar (No. 13) up from below to achieve this.

HINT - Follow the nailing line of the framing on the roof panel so that you are more likely to fix into the ridge bar below.

10x60mm Screws

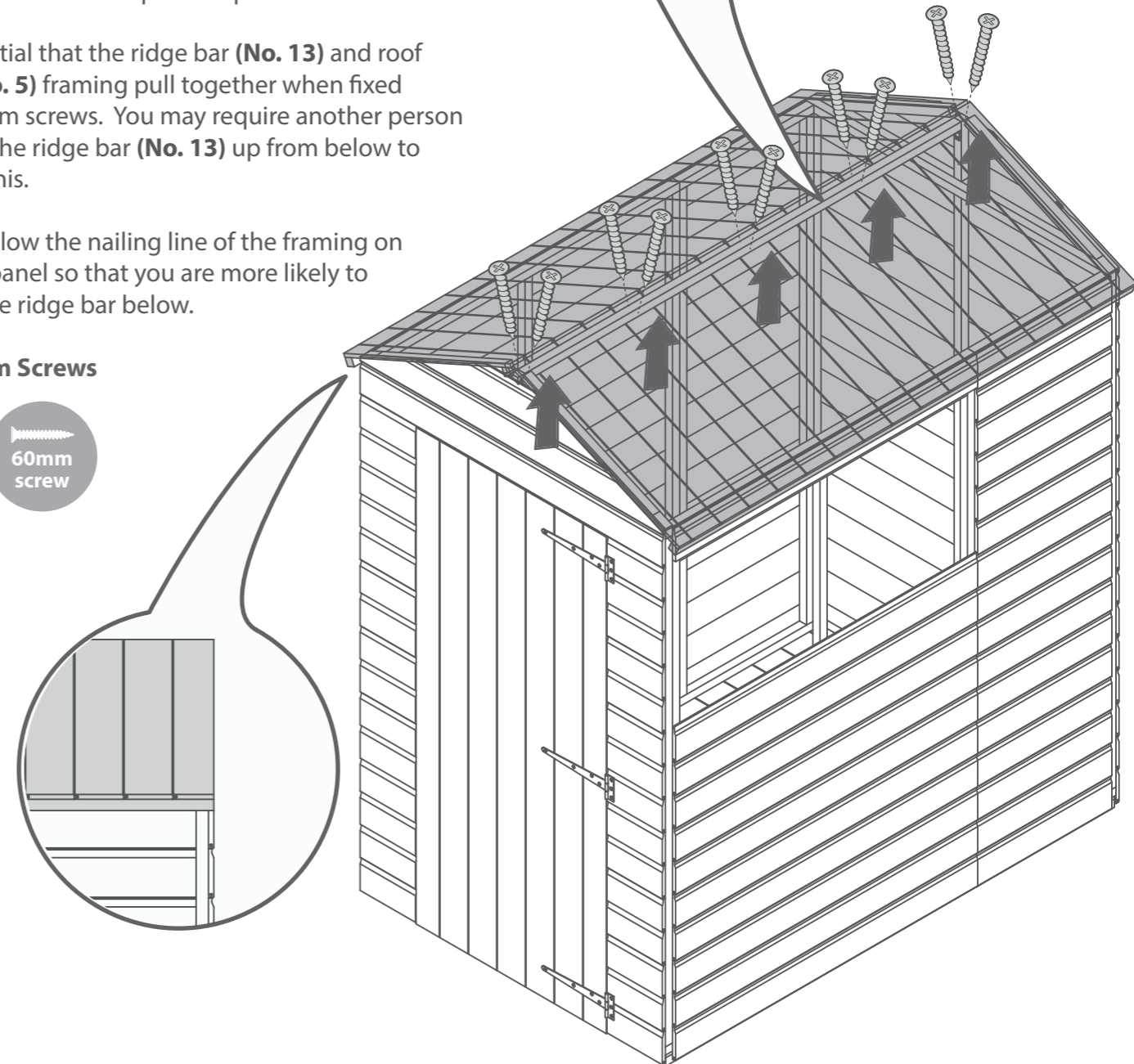

Step 10

Use 40mm screws to fix the roof (No. 5) down the sides and at the bottom being sure that the screws attach into the framing below.

18x40mm Screws

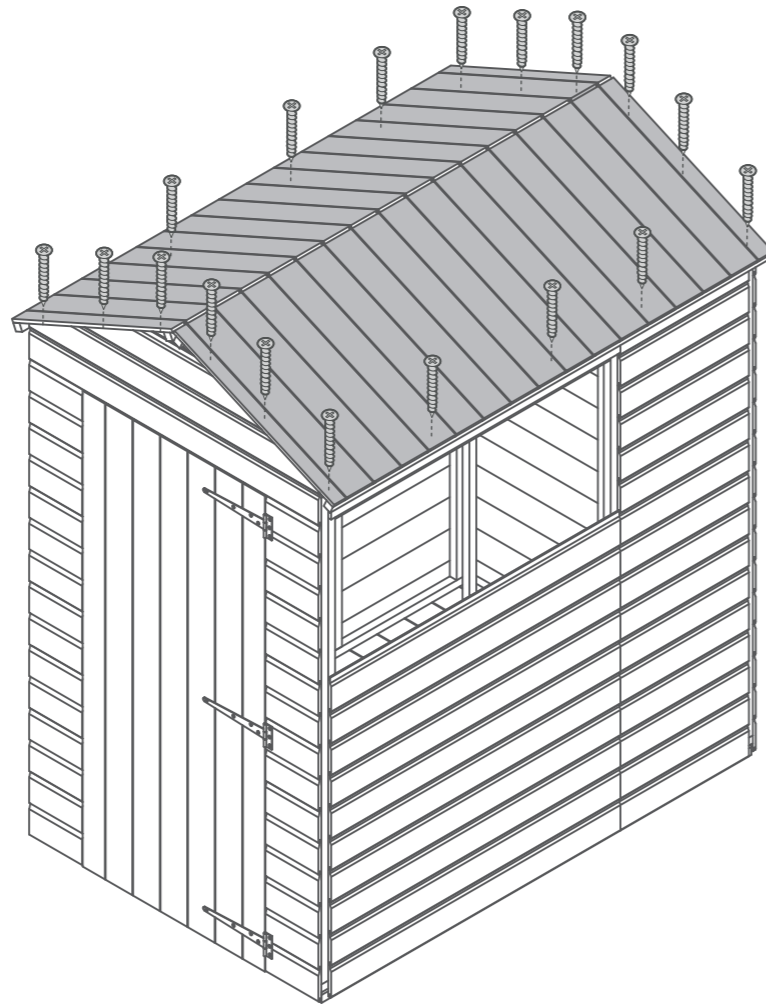

Step 11

Once the roof is fixed, attach the building to the floor with 50mm screws.

Ensure the screws go through the panel into the floor framing

20x50mm Screws

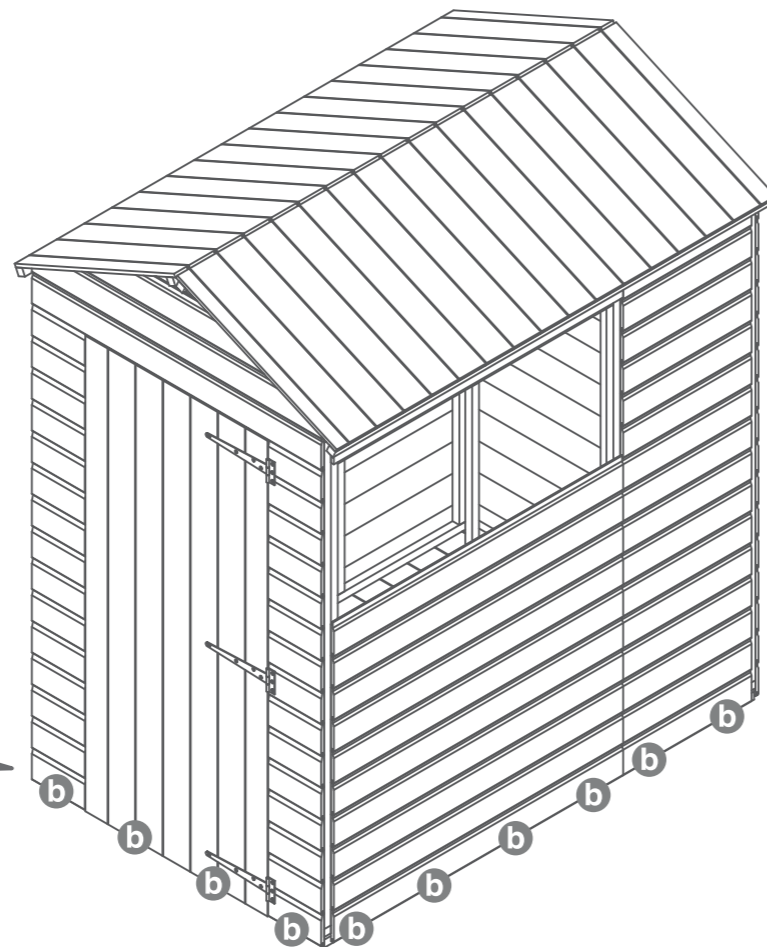
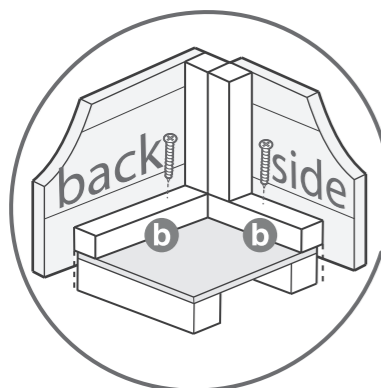

Step 12

Parts needed - No. 14 QTY 4
No. 15 QTY 3
No. 16 QTY 1
No. 23 QTY 2
No. 24 QTY 1

- Fix 4x Inner Window Strip (No. 14) to the sides of the framing exposed in the window gap of the Window Panel (No. 8) using 3x30mm screws per Strip .
- Place the Plastic Window Cill (No. 24) into the window panel (No. 1) opening as shown in the illustration. Fix screws through cill for extra support using 3x30mm screws.
- Fit the styrene sheets (No. 23) on top of the Plastic Window Cill (No. 24).

**For added weather protection fit your windows using silicone sealant around the outside edges.*

***When positioning the styrene sheets ensure there is an equal distance on all sides.*

- Attach 1x Outer Window Strip (No. 16) along the top of the window opening. Followed by attaching 3x Outer Window Strips (No. 15) to either side of the windows and the centre. Secure into place using 3x30mm screws per strip. ****You may need to cut these to fit.****

Repeat this process for the other Window Panel

27x30mm Screws



*Cut down trims to fit

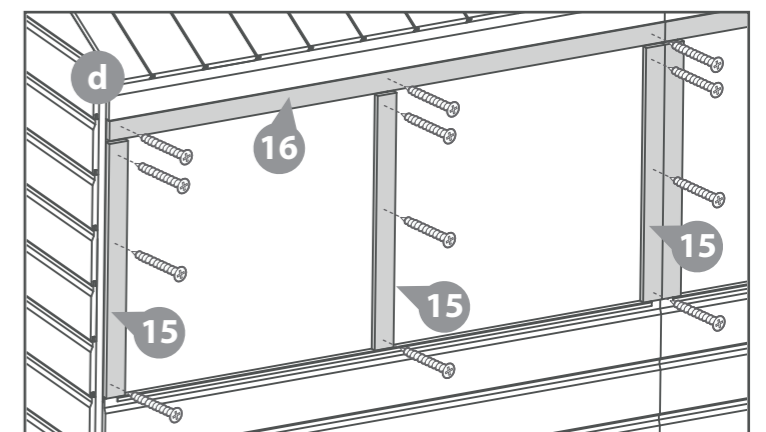
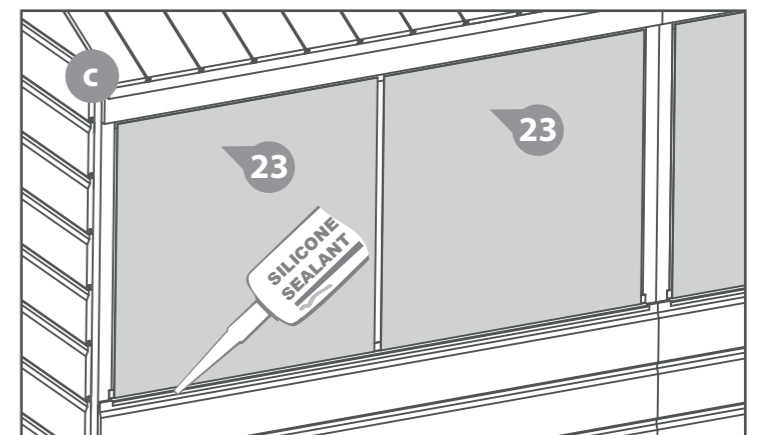
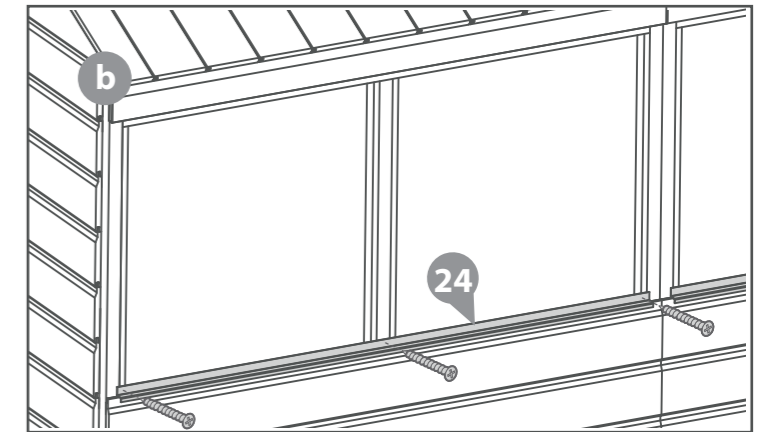
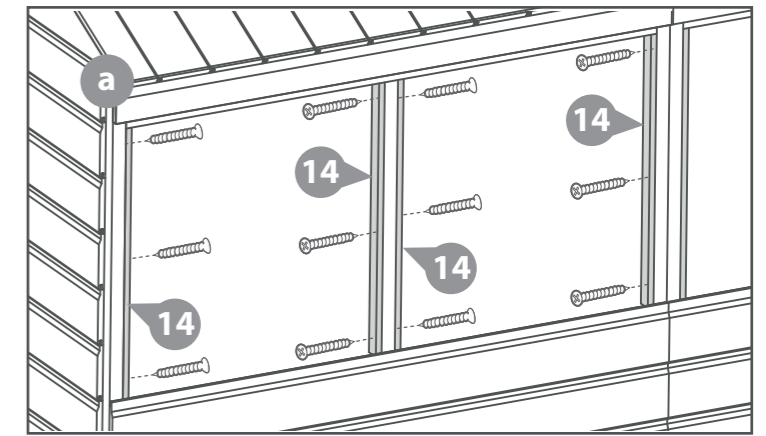
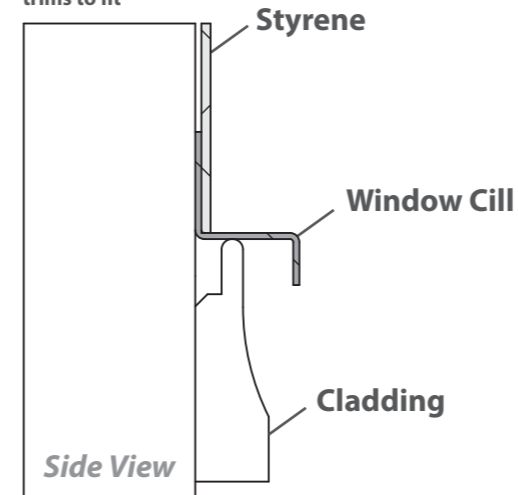

Step 13

Parts needed - No. 22 QTY 1

Cut the felt (No. 22) into two sheets at 1900mm. Lay onto roof as shown in diagram ensuring there is a 50mm overhang around the sides.

Apply the felt tacks with a 100mm space per tack.

66x Tacks

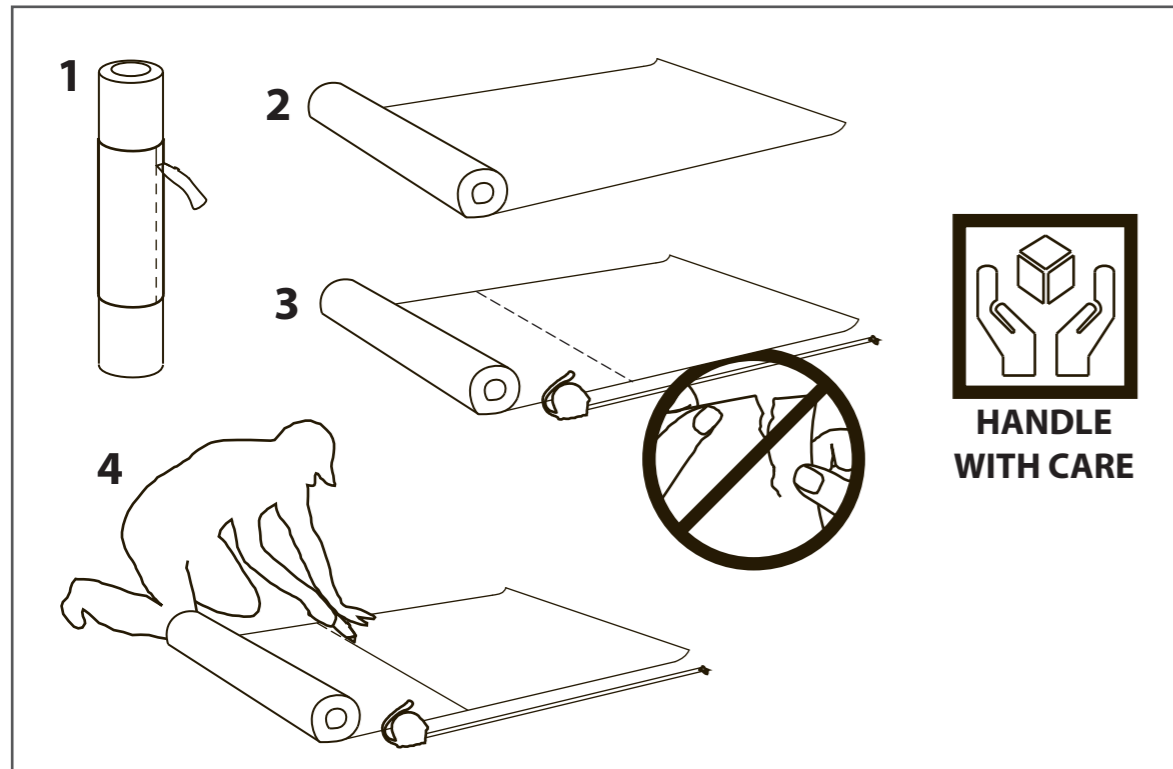
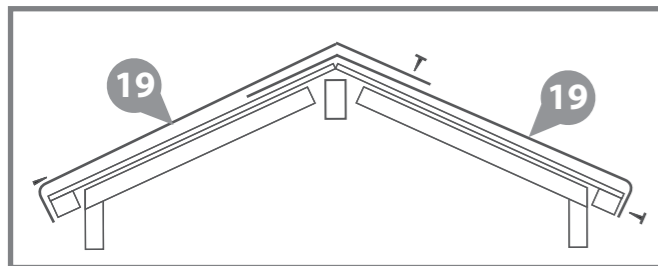
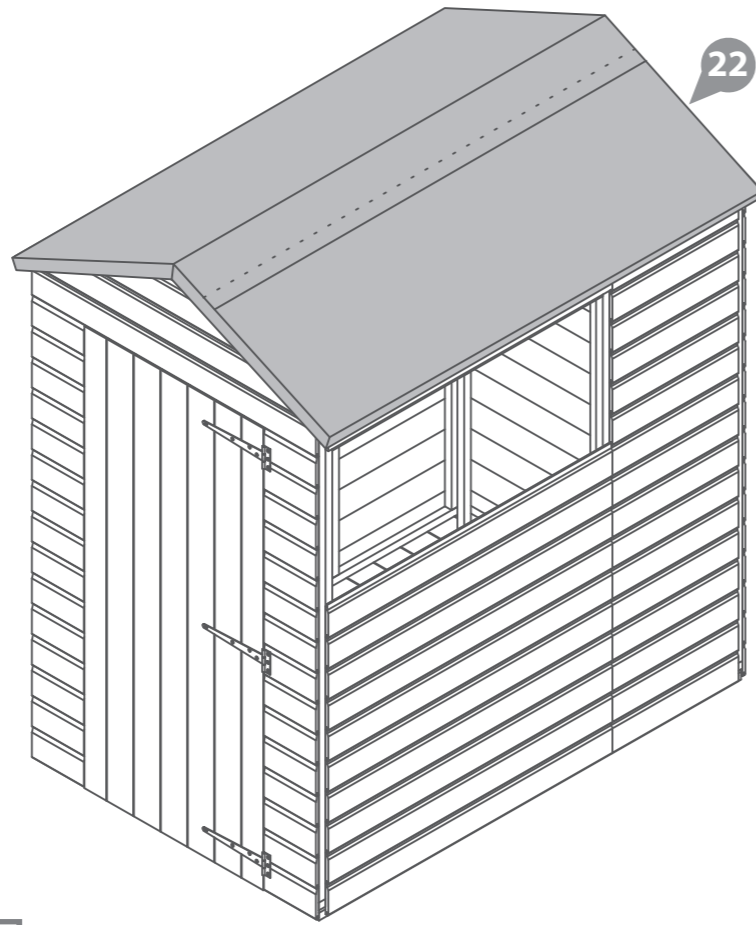
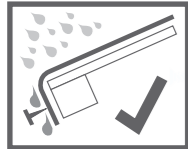

Step 14

Parts needed - No. 10 QTY 6

Fit the Cover Trims (No. 10) over each panel joint and corner of the building as shown in the illustration using 30mm screws. Pre drill to avoid splitting.

18x30mm Screws

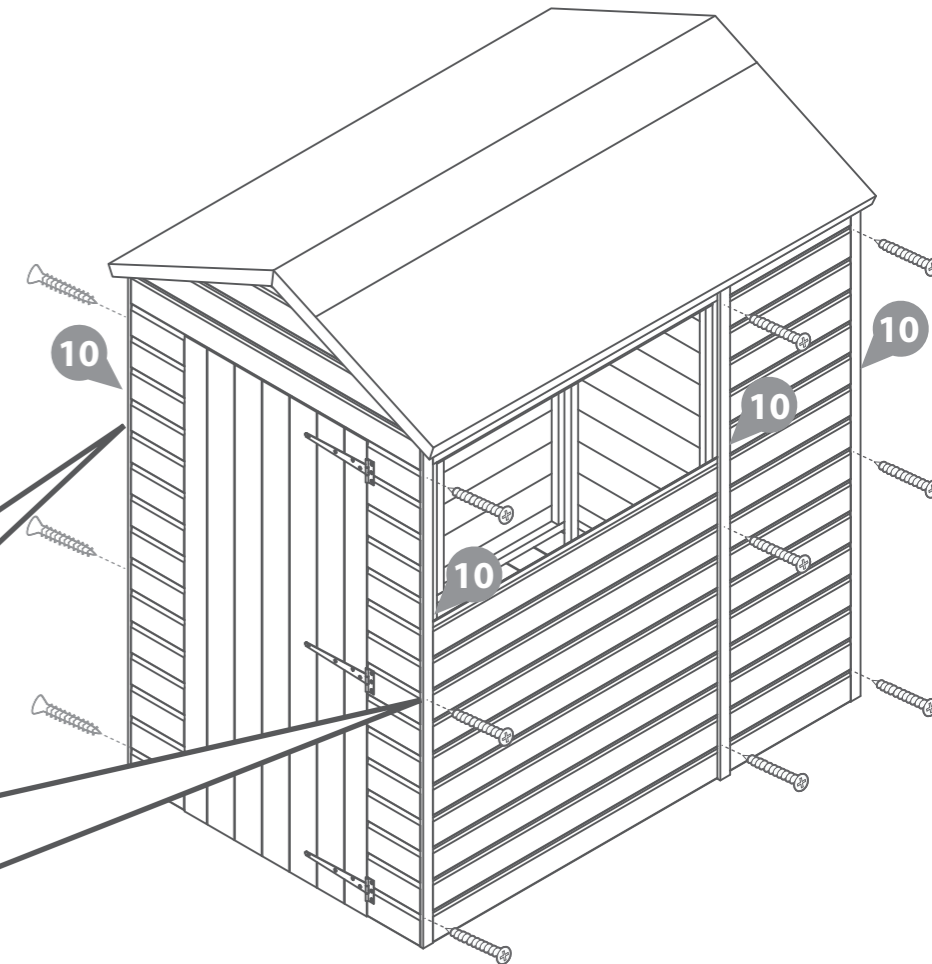
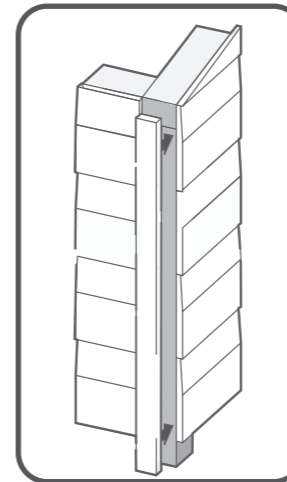

Step 15

Parts needed - No. 11 QTY 4
No. 17 QTY 2

Fit the Fascias (No. 11) to the roof over the felt and secure in place with 40mm screws as shown. Pre drill to avoid splitting.

Followed by adding the Finials (No. 17) over the Fascias using x2 40mm screws per Finial.

16x40mm Screws

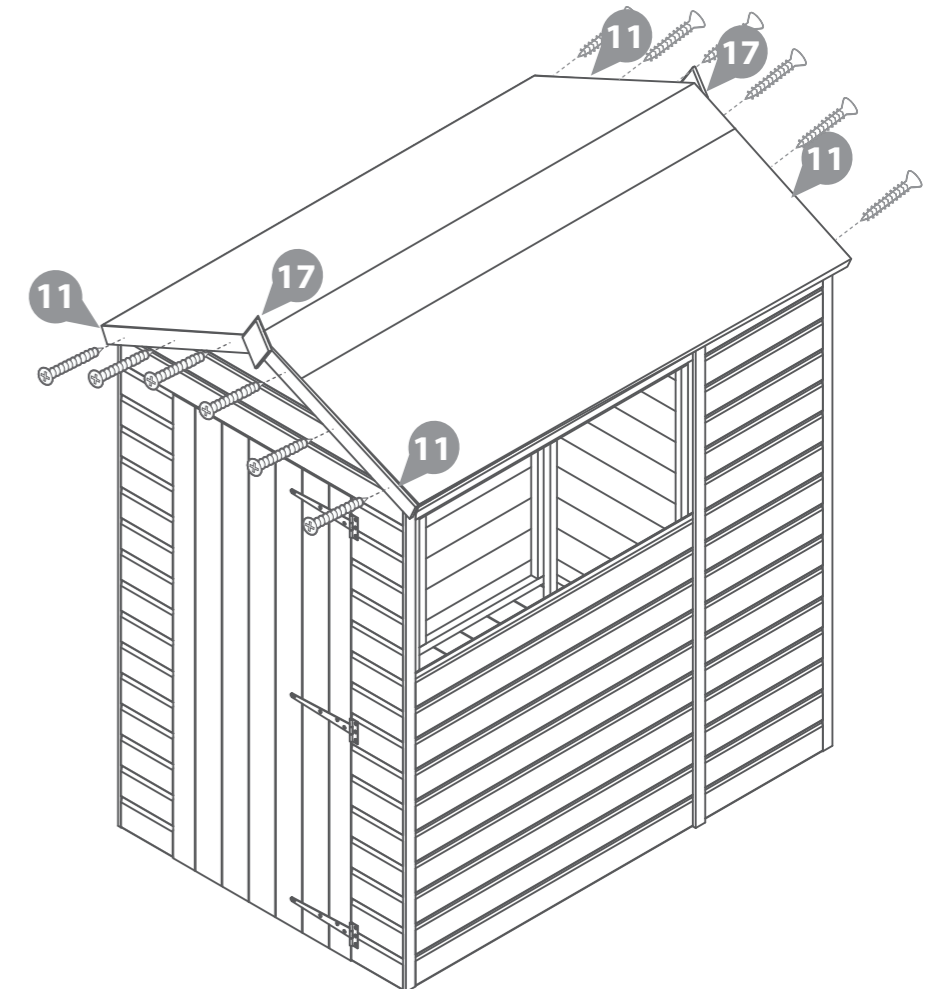
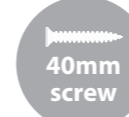

Step 16

Parts needed - No. 9 QTY 2
No. 11 QTY 1

- a** Use 4x30mm Screws to fix each beading strips (No. 9) onto the insides of the Door Panel (No. 1) opening. Ensure that the screw is parallel with the door frame when fixing the strip to the Door Panel as shown in the close up view.

8x30mm Screws



30mm screw

- b** Attach the Inner Door Block (No. 12) to the door (No. 4) using 2x30mm screws, in the positions illustrated. Screw through the door cladding into the blocks using 30mm screws

2x30mm Screws



30mm screw

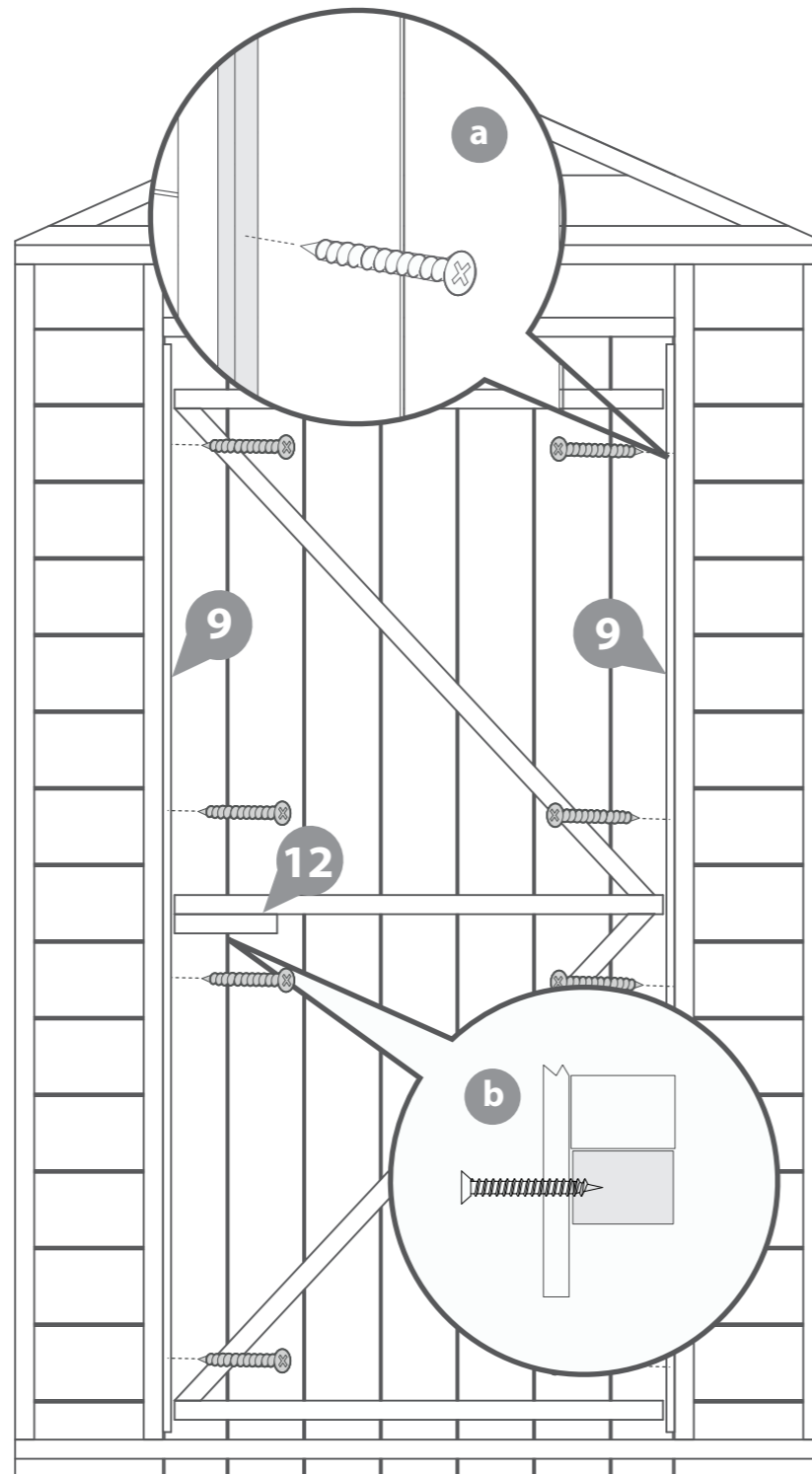

Step 17

Parts needed - No. 20 QTY 1

Screw the Pad Bolt (No. 20) on to the door (No. 4) and the retainer to the door panel (No. 1) using 10x30mm screws. Make sure that you screw into the framing behind.

10x30mm Screws.



30mm screw

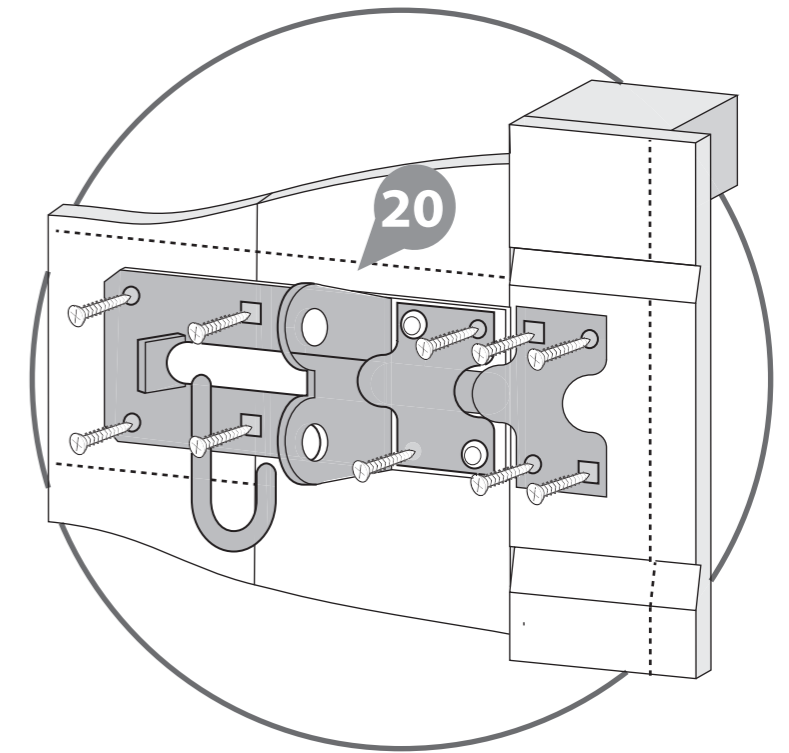

Step 18

Parts needed - No. 21 QTY 2

Fix the Turn Button (No. 21) onto the Door Panel (No. 1) using 1x30mm screw for each one.

These turn buttons help to keep your doors straight during high and low levels of moisture content in the air.

2x30mm Screws



30mm screw

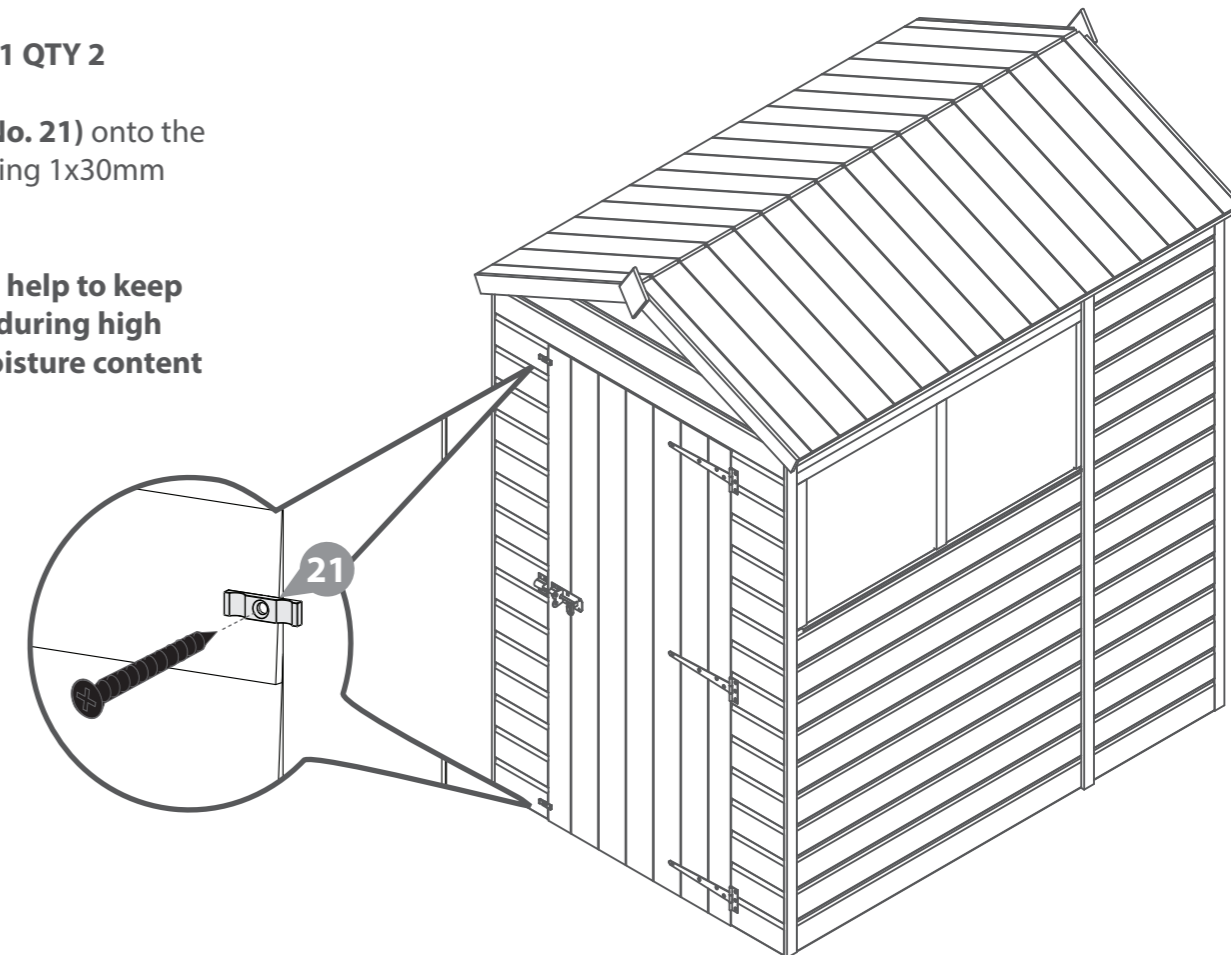

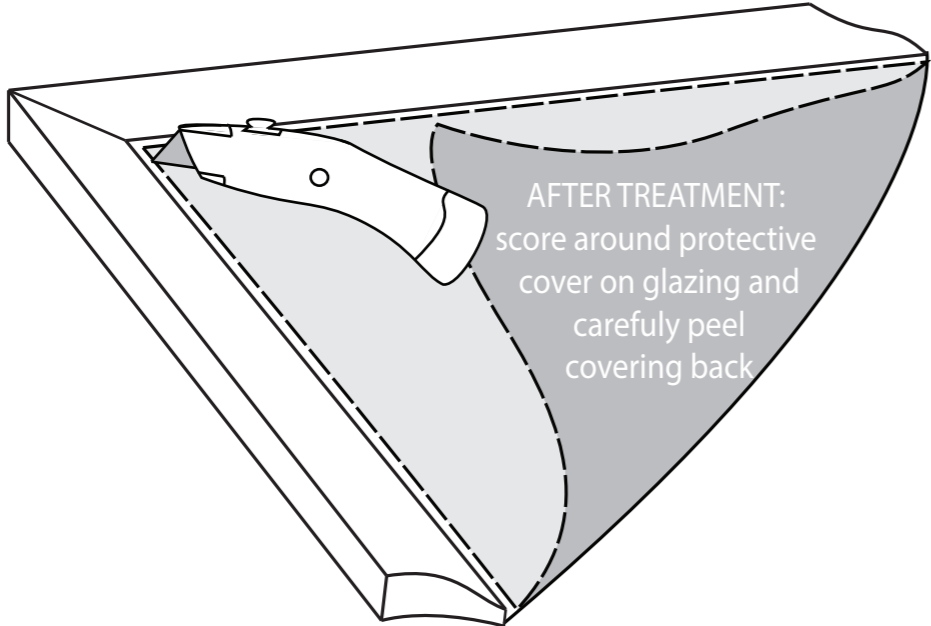

All our garden buildings have been designed and manufactured with care and attention to be the perfect addition to your outdoor space. To ensure you do get the best out of your new garden building and to increase the longevity we advise that you follow the product instructions and our manufacturer's recommendations as detailed below. Thank you for choosing a Mercia Garden product!

1 Choosing the most suitable location for your garden building...

A minimum of 60cm should be left around the perimeter of your garden building to allow access for maintenance, annual treatment and to allow air flow around the building.

Where possible you should avoid placing your garden building underneath large trees to prevent the tree causing damage to the building.

2 Preparing the base for your garden building...

All our buildings must be built on a firm, level base to ensure the longevity of the building and prevent the wood from distorting. We recommend either concrete, concrete slabs or a wooden base, such as our 'Portabase'.

The base should be slightly smaller than the external measurement of the building, i.e. the cladding should overlap the base, creating a run off for water and preventing water from pooling underneath the building.

We also recommend that the floor of the garden building is a minimum of 25mm above the surrounding ground level to avoid flooding.

3 After installation...

Once your garden building has been installed it will need to be treated as soon as possible and annually to prevent the timber from deteriorating and to waterproof it. This is required to maintain the anti-rot guarantee.

Dip Treated buildings - Require a preservative treatment to protect against rot and decay and a waterproof treatment to prevent water ingress

Pressure Treated buildings - Require a waterproof treatment to prevent water ingress

Log Cabins/Insulated Garden Rooms - Are supplied untreated and require a preservative and waterproofing treatment

We also recommend using a silicon sealant on the inside and outside of the windows as soon as possible after assembly and treatment to fully seal the windows.

Roofing felt/covering should be checked annually and replaced or fixed accordingly.

4 General maintenance and wood characteristics

As wood is a natural material it may be affected by the following:

Shrinkage and warping - The timber used in the construction of your garden building will have retained some of its natural moisture content. The moisture content of the timber will vary, depending upon prevailing environmental conditions, which will result in the components either naturally expanding or contracting. As the components dry out shrinkage may occur. A good waterproofing treatment from the start is the best protection to minimise the effect of moisture loss/intake.

In extended periods of very warm weather getting some moisture to the building will help the overall balance. You can do this by spraying it down lightly with a garden hose. In contrast after snow fall try to remove the snow as best as possible from the roof to prevent moisture intake and to remove the extra weight.

Top tip - using a garden brush will help you to reach the highest part of the building to remove snow and any debris left from bad weather.

Damp and mould - During the winter months, cold and damp conditions can result in an increased amount of moisture within your garden building, especially when used infrequently. Condensation can form on the timber and other items stored within your garden building. If left this moisture is likely to cause mould and mildew. To prevent the build-up of moisture, we recommend leaving the door or windows of your building open from time to time, to allow the fresh air to circulate. We also advise against storing wet or damp items in your garden building as this will also increase the level of moisture in the building. If mould or mildew does start to form within your building we recommend using an anti-mould cleaner to remove it and to prevent it spreading, which if left untreated could permanently damage your garden building.

Splits, cracks and knots - You may notice small splits and cracks in some components or holes may appear where knots shrink and fall out. This will not affect the structure of your Garden building however if you wish to fill them this can be easily done using any good quality wood filler.

Sap - is naturally occurring in wood and may appear in some boards of your garden building. If you wish to remove the sap, we advise waiting until it is dry and then using a sharp knife to carefully remove it. If the removal of the sap causes a hole in the timber, we recommend using a good quality wood filler to fill it.

For more handy hints and tips on how to care and maintain your garden building please refer to the MGP Customer Portal at www.mgplogistics.co.uk

Any further questions?

Contact our
Customer Service
Team on:
01636 821215

1 Manufacturer's Warranty

All Mercia Garden Products are supplied with a 1 year warranty on all parts against manufacturing defects.

This warranty does not cover movement, warping or splitting of timber products over time.

This warranty will be voided if any of the following occur:

1. The building has been customised or modified/adapted in any way.
2. The person claiming is not the original purchaser of the building.
3. Any damage has been caused by or as a result of misuse.
4. The building has not been maintained and cared for in accordance to our advisories and manufacturer's recommendations.
5. The building has not been treated annually or as per the manufacturer's recommendations, please ensure receipts are kept to validate this claim.
6. The building has not been erected, fitted or installed as per the supplier instructions.
7. The building has not been erected on a suitable sized firm flat, solid level concrete/slab base or placed on pressure treated bearers.
8. The building is or has been placed with 2 feet (60cm) of any obstructions (walls, trees, plants, fences etc.) which can allow moisture to penetrate the timber.
9. The roofing felt has been incorrectly fitted or damaged allowing water ingress, or not properly maintained.
10. Any windows and joints have not been sealed, inside and out, with silicone or other watertight sealant.
11. Any timber has been cut, pierced or drilled without subsequent application of approved cut-end treatment.

2 Anti-rot Guarantee

Mercia Garden Products offer a 10 year anti-rot guarantee on all dip treated (a preparatory treatment) and 15 years on all pressure treated products. This guarantee covers solid timber against rot, decay, blue stain and insect attack.

To validate the guarantee the building must be treated with a recognised wood preserver/water proof top coat (as detailed within manufacturer's recommendations) as soon as possible after assembly and annually thereafter.

This guarantee does not cover movement, warping or splitting of timber products over time.

This guarantee will be voided if any of the following occur:

1. The building has been customised or modified/adapted in any way.
2. The person claiming is not the original purchaser of the building.
3. Any damage is caused by or as a result of misuse.
4. The building has not been maintained and cared for in accordance to our advisories and manufacturer's recommendations.
5. The building has not been treated annually or as per the manufacturer's recommendations, please ensure receipts are kept to validate this claim.
6. The building has not been erected, fitted or installed as per the supplier instructions.
7. The building has not been erected on a suitable sized firm flat, solid level concrete/slab base or placed on pressure treated bearers.
8. The building is or has been placed with 2 feet (60cm) of any obstructions (walls, trees, plants, fences etc.) which can allow moisture to penetrate the timber.
9. The roofing felt has been incorrectly fitted or damaged allowing water ingress, or not properly maintained.
10. Any windows and joints have not been sealed, inside and out, with silicone or other watertight sealant.
11. Any timber has been cut, pierced or drilled without subsequent application of approved cut-end treatment.