

# General Instructions

Please retain product label and instructions for future reference

## 6X4 OVERLAP APEX

### BEFORE YOU START PLEASE READ INSTRUCTIONS CAREFULLY

- Check the pack and make sure you have all the parts listed.
- When you are ready to start, make sure you have the right tools at hand (not supplied) including a Phillips screwdriver, Stanley knife, wood saw, step ladder and drill with 2mm bit.
- Ensure there is plenty of space and a clean dry area for assembly.

### TIMBER

As with all natural materials, timber can be affected during various weather conditions. For the duration of heavy or extended periods of rain, swelling of the wood panels may occur. Warping of the wood may also occur during excessive dry spells due to an interior moisture loss. Unfortunately, these processes cannot be avoided but can be helped. It is suggested that the outdoor building is sprayed with water during extended periods of warm sunshine and sheltered as much as possible during rain or snow.

Once your garden building has been installed it will need to be treated as soon as possible and annually to prevent the timber from deteriorating and to waterproof it. This is required to maintain the anti-rot guarantee.

Dip Treated buildings - Require a preservative treatment to protect against rot and decay and a waterproof treatment to prevent water ingress

Pressure Treated buildings - Require a waterproof treatment to prevent water ingress

Log Cabins - Are supplied untreated and require a preservative and waterproofing treatment.

### BUILDING A BASE

When thinking about where the building and base is going to be constructed: Ensure that there will be access to all sides for maintenance work and annual treatment.

Ensure the base is level and is built on firm ground, to prevent distortion. Refer to diagrams for the base dimensions, The base should be slightly smaller than the external measurement of the building, i.e. The cladding should overlap the base, creating a run off for water. It is also recommended that the floor be at least 25mm above the surrounding ground level to avoid flooding.

### TYPES OF BASE

- Concrete 75mm laid on top of 75mm hard-core.
- Slabs laid on 50mm of sharp sand.

**Whilst all products manufactured are made to the highest standards of Safety and in the case of childrens products independently tested to EN71 level, we cannot accept responsibility for your safety whilst erecting or using this product.**

Refer to the instructions pages for you specific product code



x2

All building's should be erected by two adults



Winter = High Moisture = Expansion  
Summer = Low Moisture = Contraction



2mm Drill bit

For ease of assembly, you **MUST** pilot drill all screw holes and ensure all screw heads are countersunk.



### CAUTION

Every effort has been made during the manufacturing process to eliminate the prospect of splinters on rough surfaces of the timber. You are strongly advised to wear gloves when working with or handling rough sawn timber.

### \*\*Protim Aquatan T5 (621)\*\*

Your building has been treated with **Aquatan**.

Aquatan is a water-based concentrate which is diluted with water, the building as been treated by the correct application of Aquatan solution and then allowed to dry.

Aquatan is a decorative finish to colour the wood, which is applied industrially to timber fence panels and garden buildings.

**Aquatan undiluted contains:** boric acid, sodium hydroxide 32% solution, aqueous mixture of sodium dioctyl sulphosuccinat and alcohols: 2, 4, 6-trichlorophenol.

For assistance please contact customer care on: 01636 880514

**Mercia Garden Products Limited,  
Sutton On Trent,  
Newark,  
Nottinghamshire,  
NG23 6QN**

[www.mercia garden products.co.uk](http://www.mercia garden products.co.uk)

### Overall Dimensions:

Length = 1794mm  
Width = 1199mm  
Height = 1863mm

### Base Dimensions:

Length = 1763mm  
Width = 1180mm

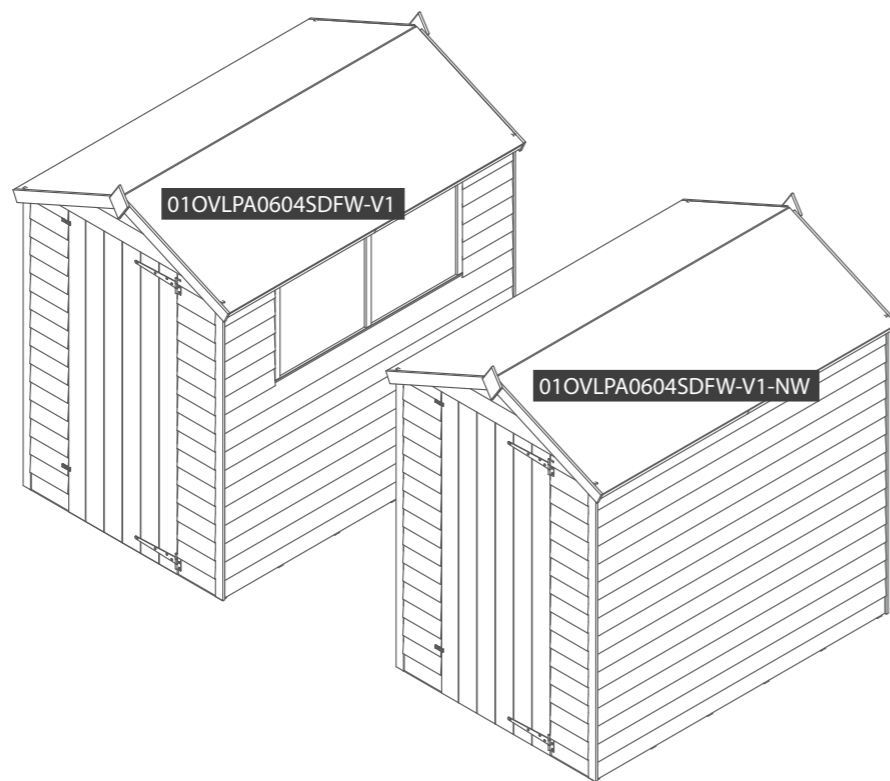

Before assembly please make sure you have a suitable base ready to erect your building



MADE IN GREAT BRITAIN

### Pre Assembly

Remove transportation blocks from the bottom of each panel before beginning assembly. Each Panel should have two

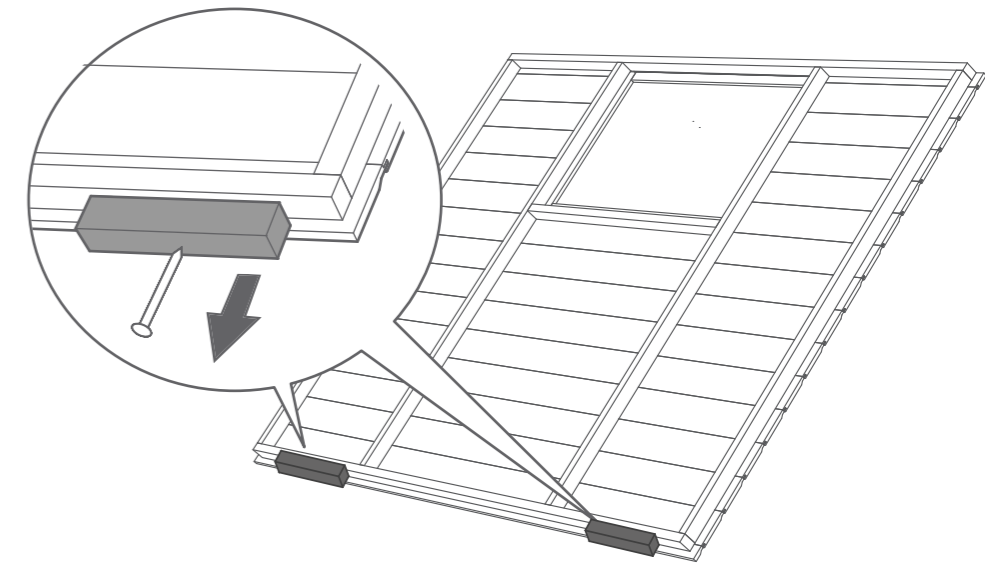

### Building Content:

- 1 **Door Gable**  
AI-01OVLDPG1832X1130-V1
- 2 **Back Gable**  
AI-01OVLPPG1832X1330-V1
- 3 **Plain Side QTY 2 (NW ONLY)**  
AI-01OVLPPS1763X1567-V1
- 4 **Window Panel (FW ONLY)**  
AI-01OVLPPWS1763X1567-V1
- 5 **Floor**  
AI-01OVLPPF1753X1175-V1
- 6 **Roof QTY 2**  
PI-03-0222
- 7 **Door QTY 2**  
AI-01MBDR1600X663-V1
- 8 **Fascia 12x60x694mm QTY 4**  
S1260-694mm
- 9 **Fixed Window Strip 12x30x546mm QTY 5 (FW ONLY)**  
S1230-546mm
- 10 **Cover Trims 12x45x1575mm QTY 4**  
S1245-1575mm
- 11 **Door Beading Strip 12x28x1541mm QTY 2**  
S1228-1541mm
- 12 **Ridge Bar 28x28x1707mm QTY 1**  
F2828-1707mm
- 13 **Eaves Frame 28x28x897mm QTY 4**  
F2828-897mm
- 14 **Finial QTY 2**  
SHED DIAMOND FINIAL
- 15 **T Hinge QTY 2**  
PI-02-1041
- 16 **Plastic Window Cill FW-V1 ONLY**  
PI-08-0013
- 17 **Turn Button QTY 2**  
PI-07-0034
- 18 **Felt**
- 19 **Styrene QTY 2 (FW ONLY)**  
PI-05-0114
- 20 **L-Bracket QTY 2**  
PI-07-0012

- | Nail Bag |                      |
|----------|----------------------|
|          | Felt Tacks x 72      |
|          | 20mm Screw x 8       |
|          | 30mm Black Screw x 2 |
|          | 30mm Screw x 62      |
|          | 40mm Screw x 48      |
|          | 50mm Screw x 41      |

Fix the T Hinges onto the doors and door frame as shown. Ensure that the screws go through the cladding and into the framing behind.

14x30mm screws

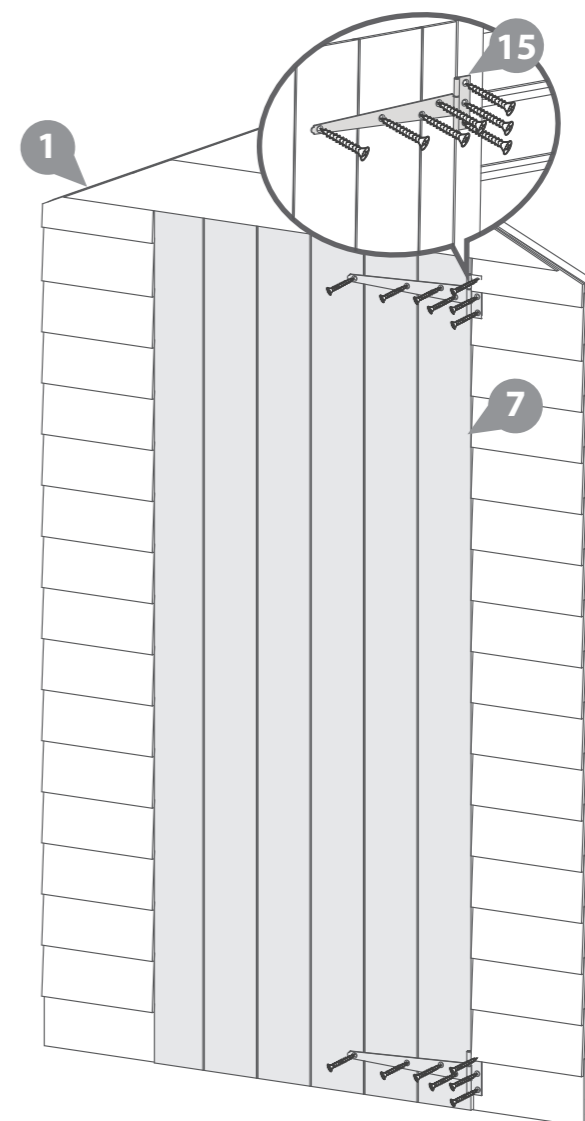

# Step 1

Place the floor on a firm and level base, ensure the base has suitable drainage free from areas where standing water can collect. See the front page for base requirements.

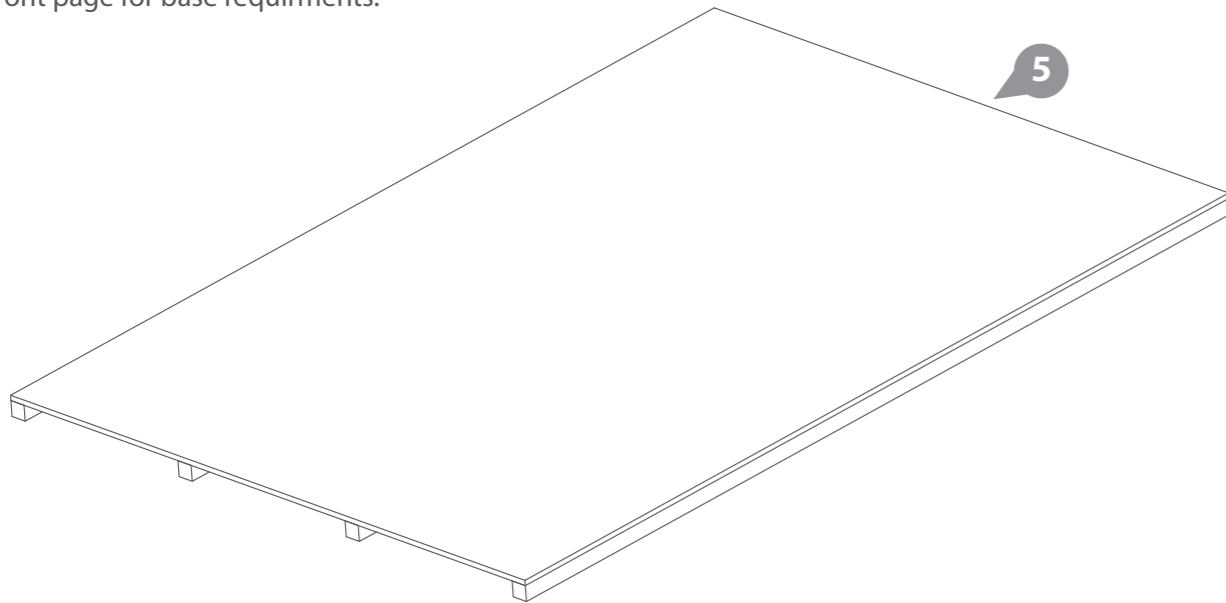

# Step 2

Fix the corners with 50mm screws as shown in diagram.

Do not secure the building to the floor until the roof is fitted. Fix the panels onto the floor using 50mm screws in alignment with the floor joists

Position the panels so there is equal spacing between the floor and cladding on all 4 sides

**3x50mm Screws**

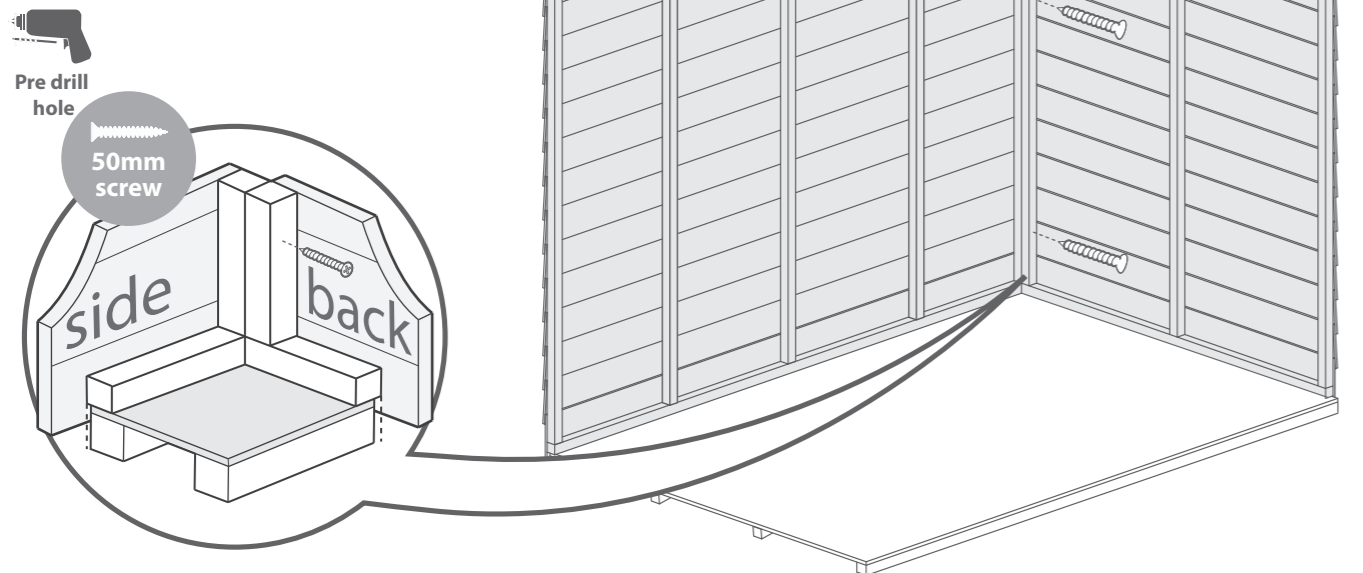

# Step 3

Fix the corners with 50mm screws as shown in diagram.

**9x50mm Screws**

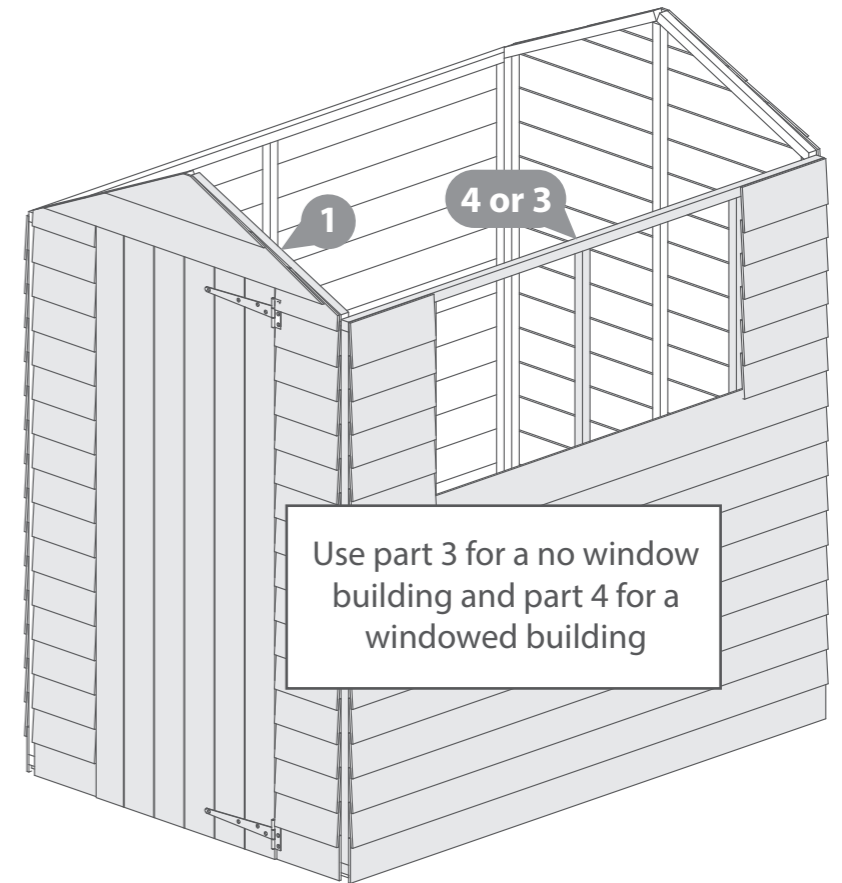
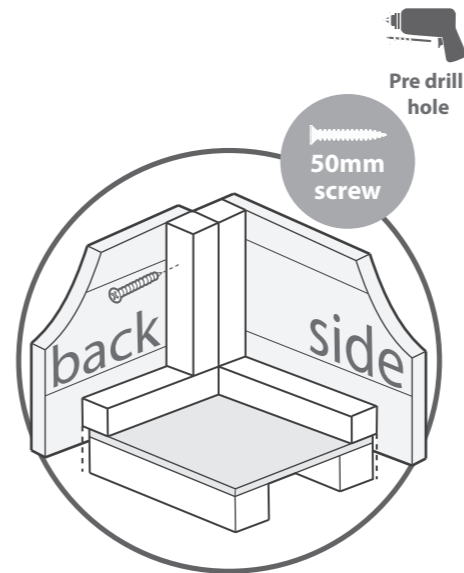

# Step 4

Place the ridge bar in between the front and back gables. Ensure the top corners of the ridge bar sit flush with the top points of the door gable. Fix the ridge bar to the gable using one L bracket for each end.

Fix with 4x20mm screws each

**8x20mm Screws**

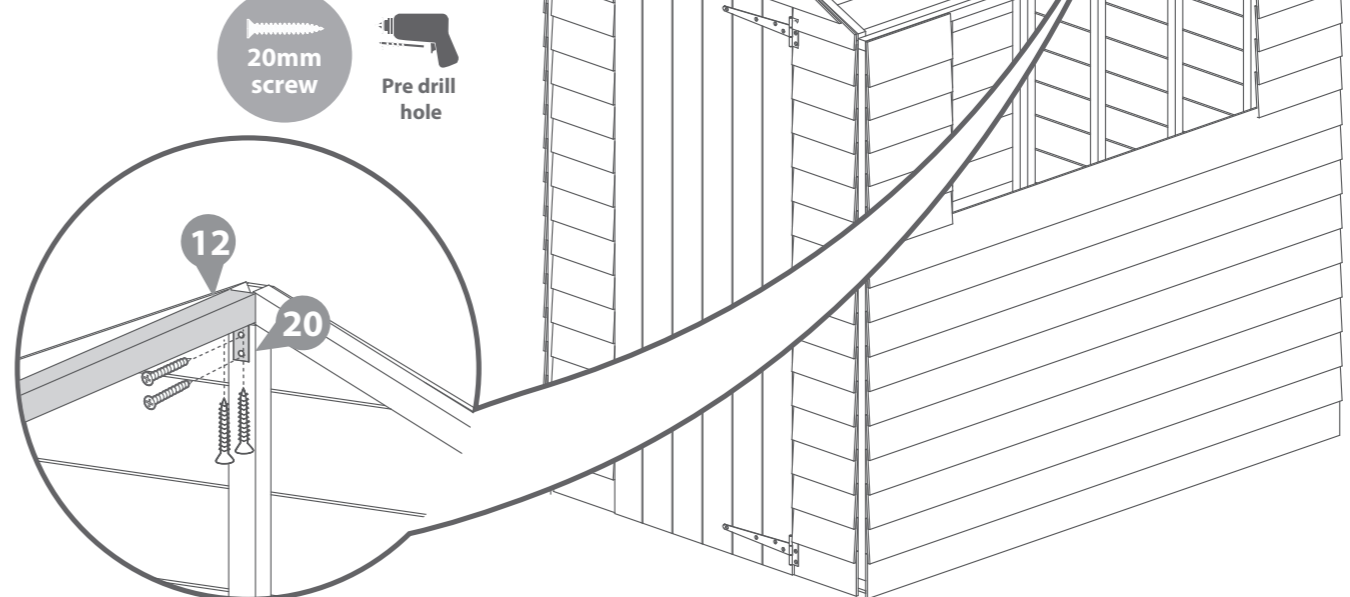

## Step 5

Fix two eaves frames to each roof sheet using 3x30mm screws per eave.

Fix the roof sheets to the roof ensuring they come together at the top using 40mm screws directly through the roof sheet at the top. Make sure to attach the roofs to the ridge bar.

**12x 30mm Screws**  
**28x 40mm Screws**

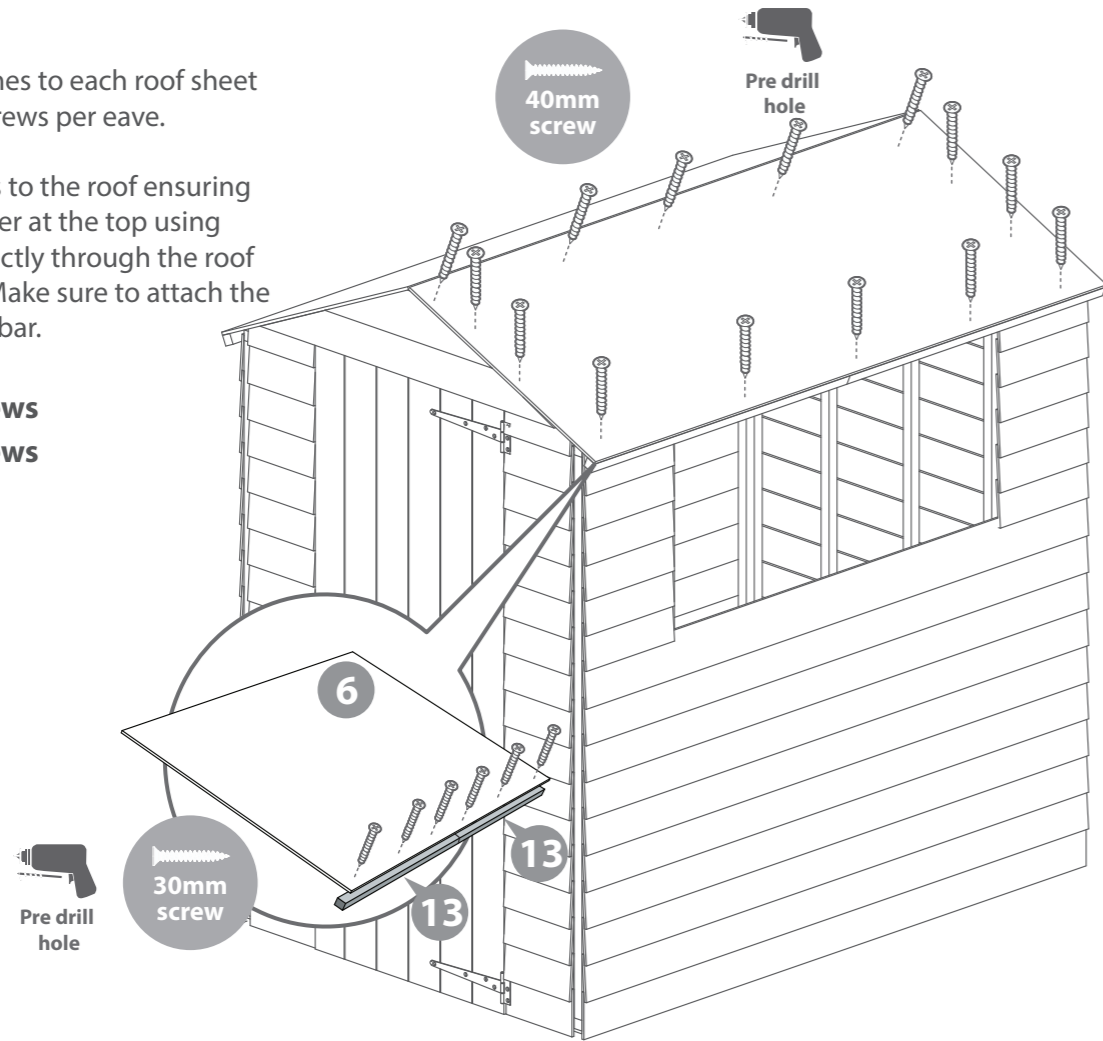

## Step 6

**b** Once the roof is fixed attach the building to the floor with 50 mm screws.

**16x 50mm Screws**

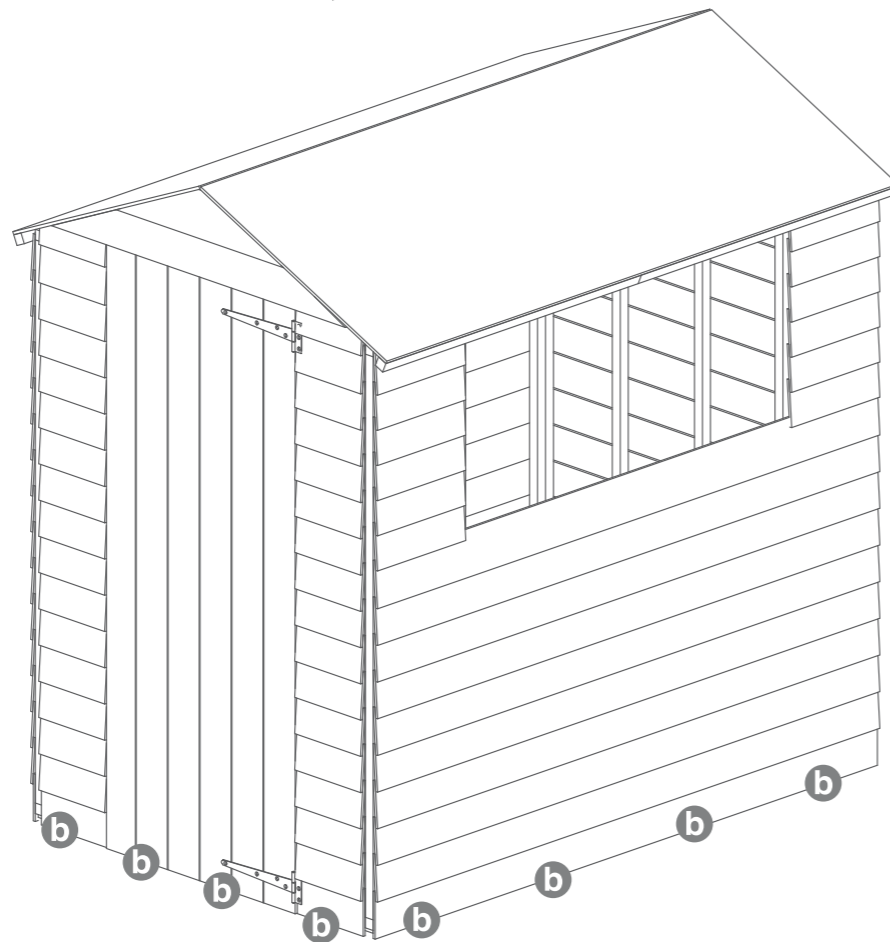

## Step 7

Cut the felt into 2 sheets at 1894mm and fix onto the roof using felt tacks as shown in diagram ensuring there is 50mm overhang around the sides.

**72x Tacks**

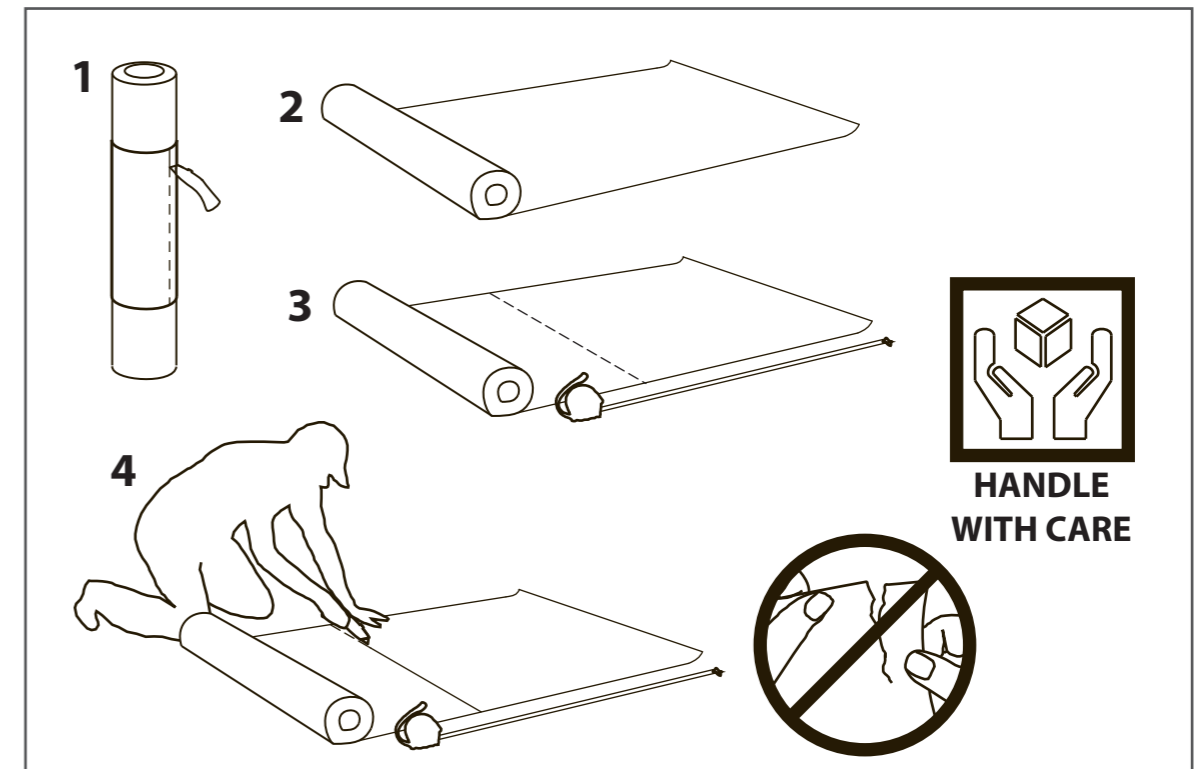
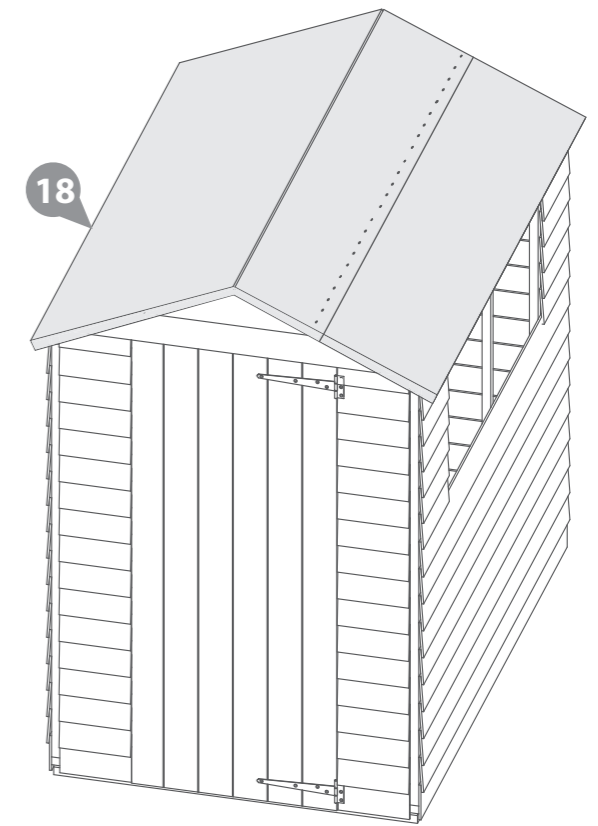
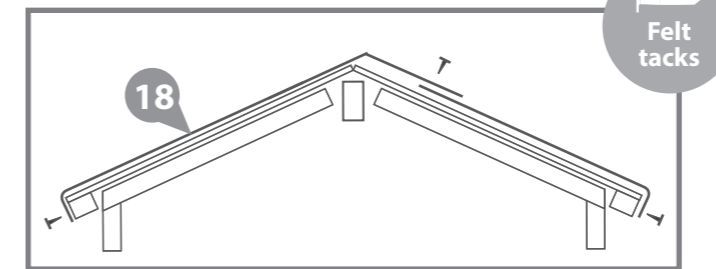
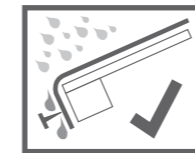

## Step 8

Fit the Cover Trims to the front and back of the building as shown in the illustration using 30mm screws. Trim the length of the cover trims to the required size before fitting if necessary. Pre drill to avoid splitting.

**12x30mm Screws**

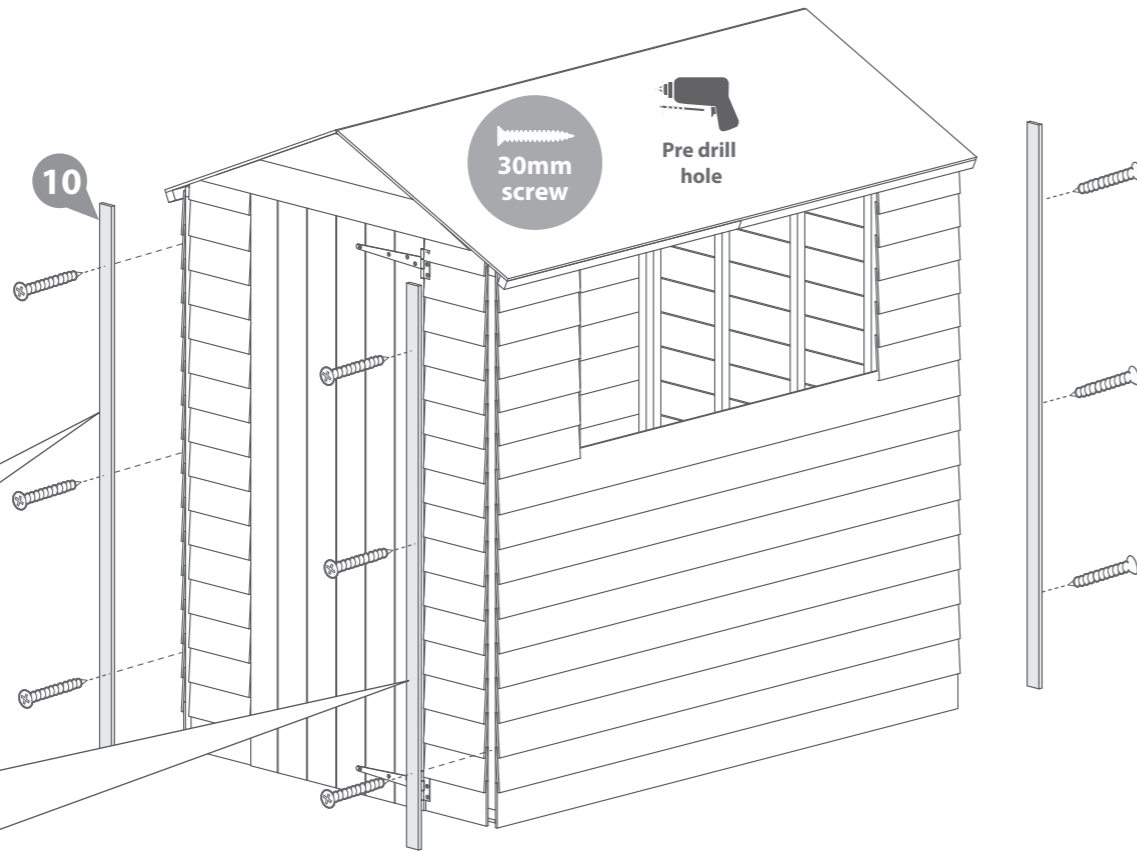
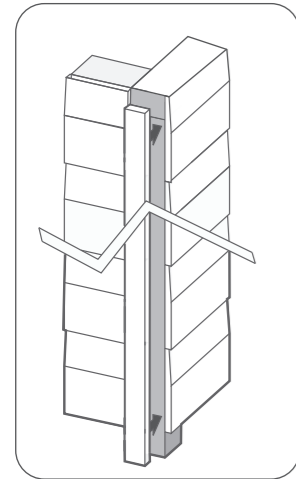

## Step 9

Attach the fascias to the roof leaving a slight overhang at the top.

Fit the fascias to the roof over the felt and secure in place with 40mm screws as shown. Pre drill to avoid splitting.

**16x40mm Screws**

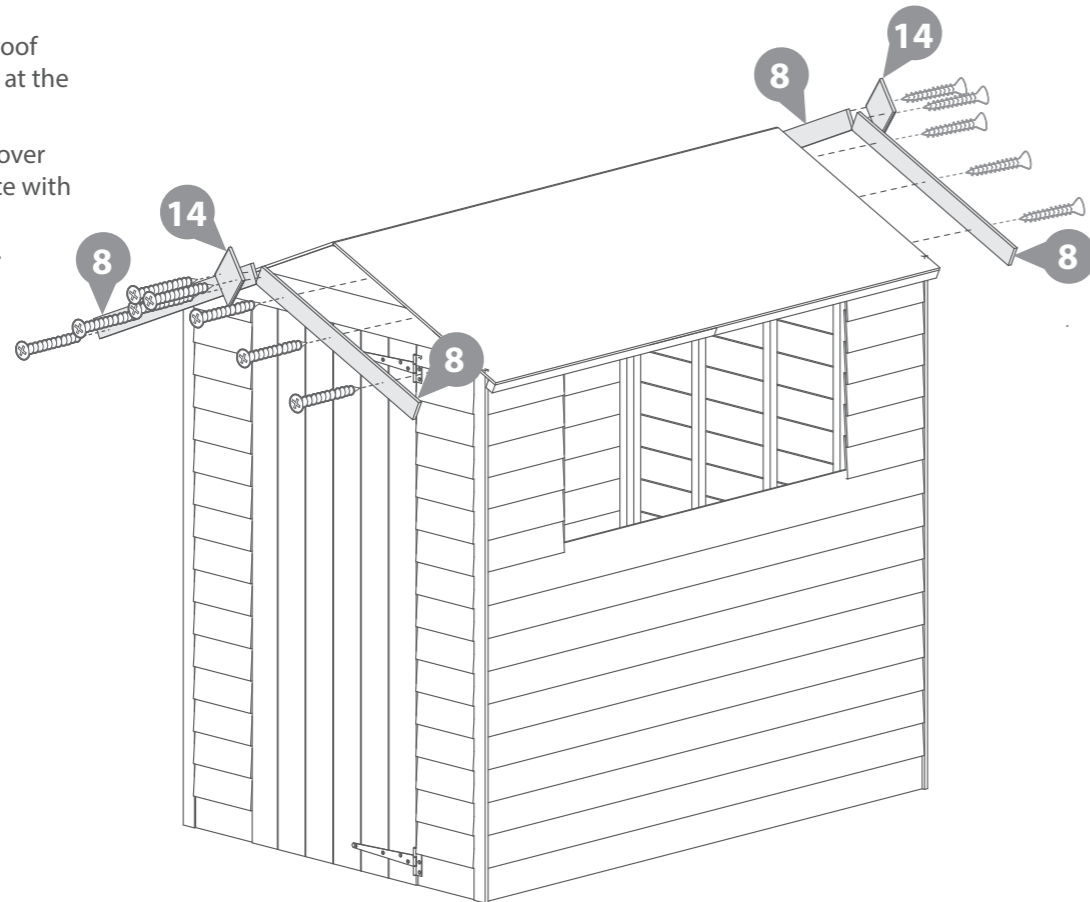
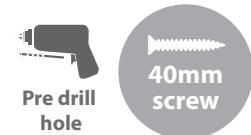

## Step 10

For the no window version go to step 11

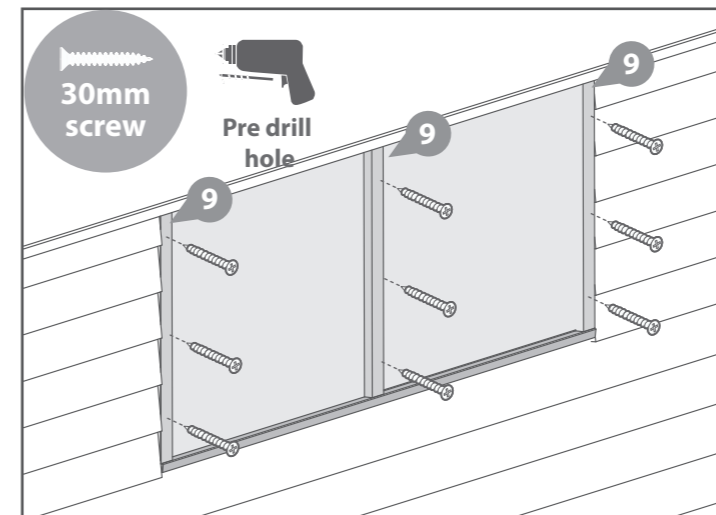
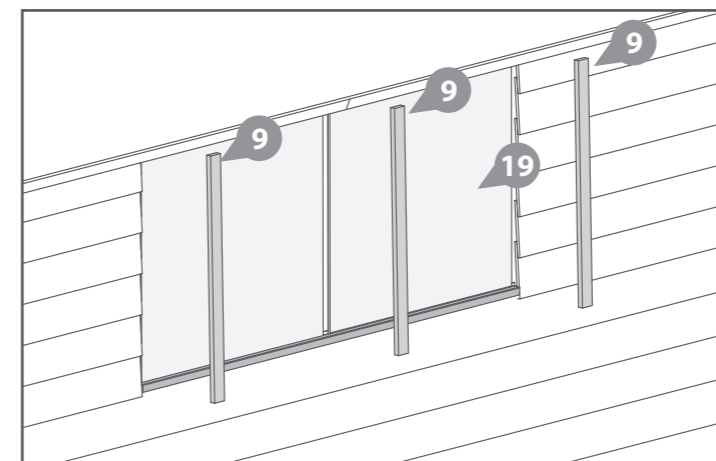
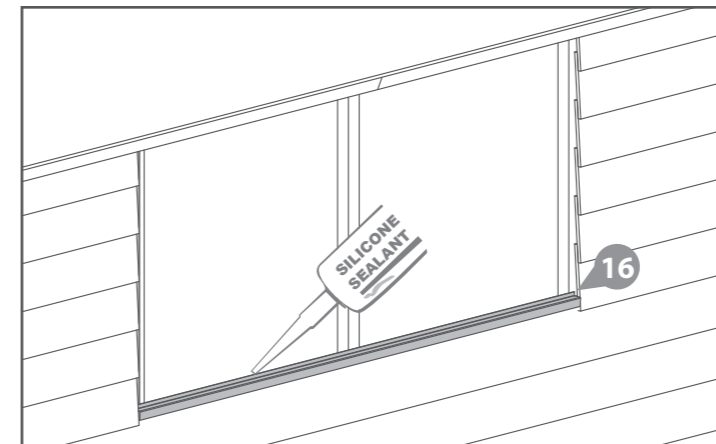
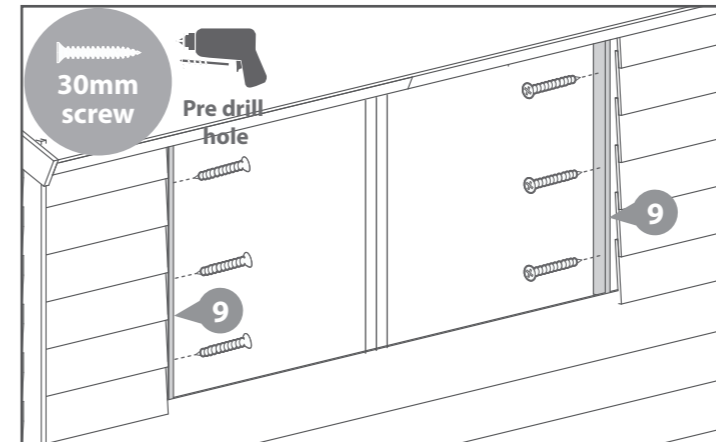

Fix the window strips to the two pieces of framing that sit alongside the outside edges of the window with 3x30mm screws for each strip.

**6x30mm Screws**

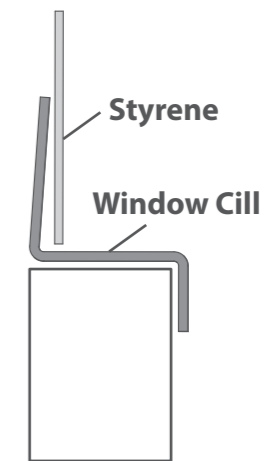

*Side View*

Place the plastic window cill onto the Window Panel and silicone in place as shown on both diagrams to the left.

Fit the styrene sheets on top of the window cill.

When positioning the styrene sheets ensure there is an equal distance between them and at either side of the windows.

Attach the three window strips at either side of the windows using 3x30mm screws each. Make sure the screws enter the framing in the window panel and not the styrene.

**9x30mm Screws**

## Step 11

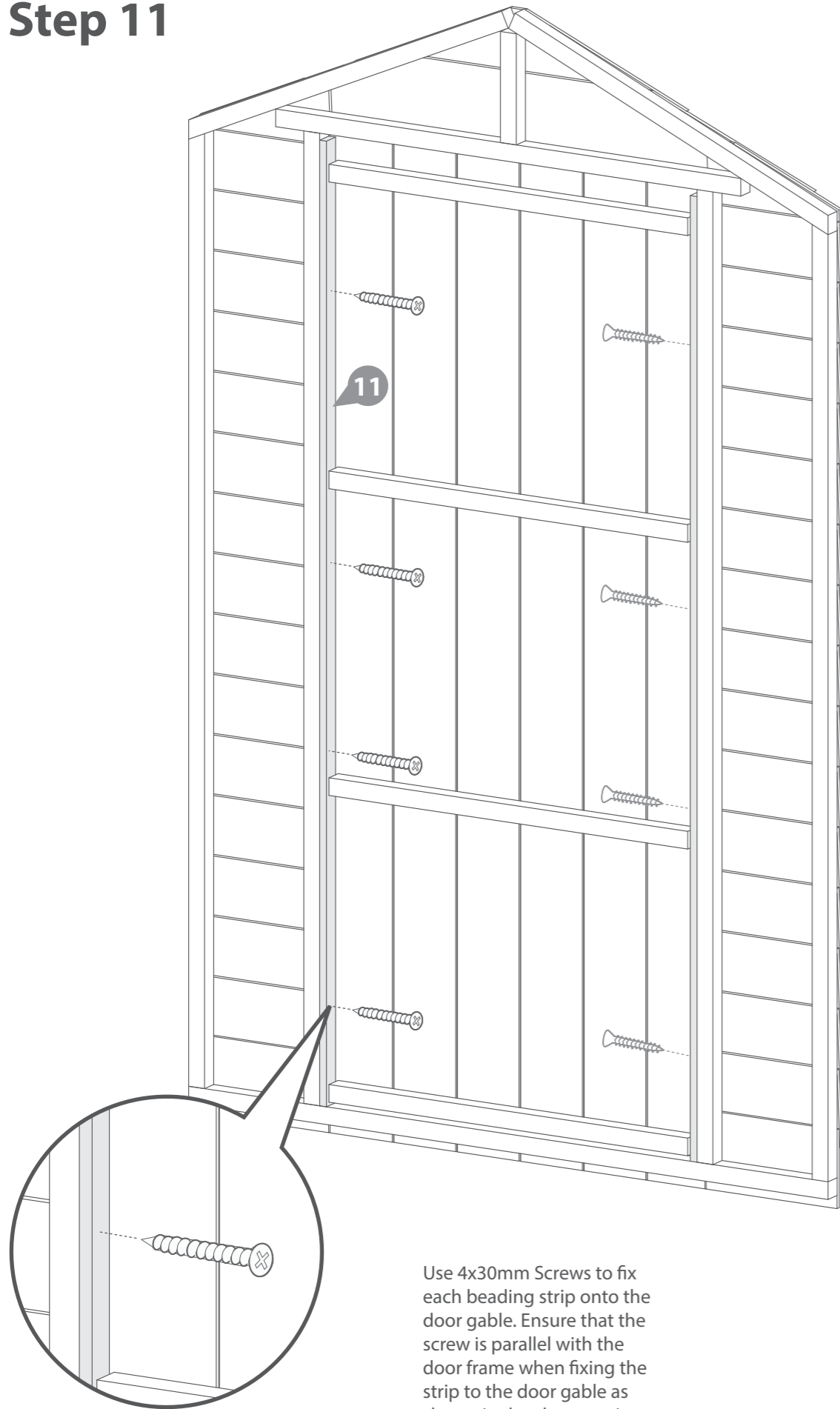

Use 4x30mm Screws to fix each beading strip onto the door gable. Ensure that the screw is parallel with the door frame when fixing the strip to the door gable as shown in the close up view.

**8x30mm Screws**

## Step 12

Fix the Turn Button onto the door gable using 1x30mm black screw for each one.

**2x 30mm Black Screw**

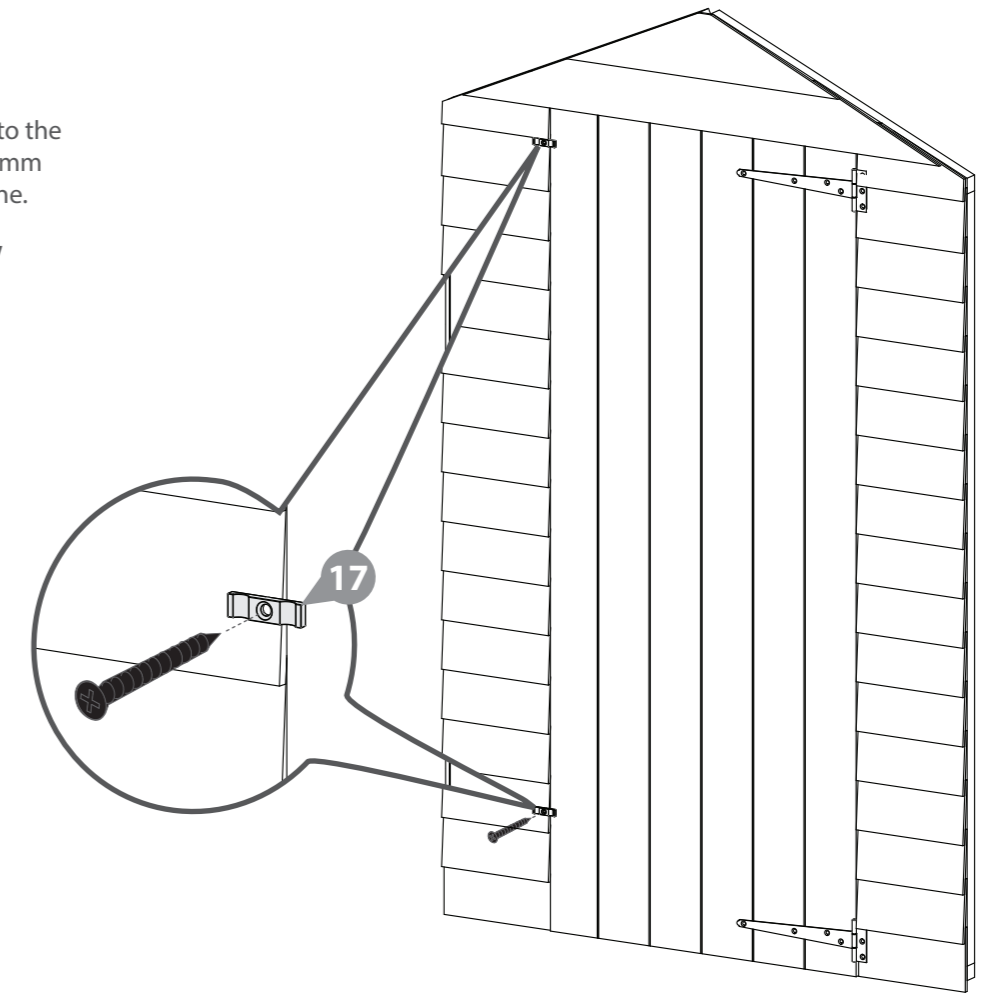
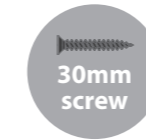

**It is ESSENTIAL that you apply wood treatment immediately after the building has been assembled.**

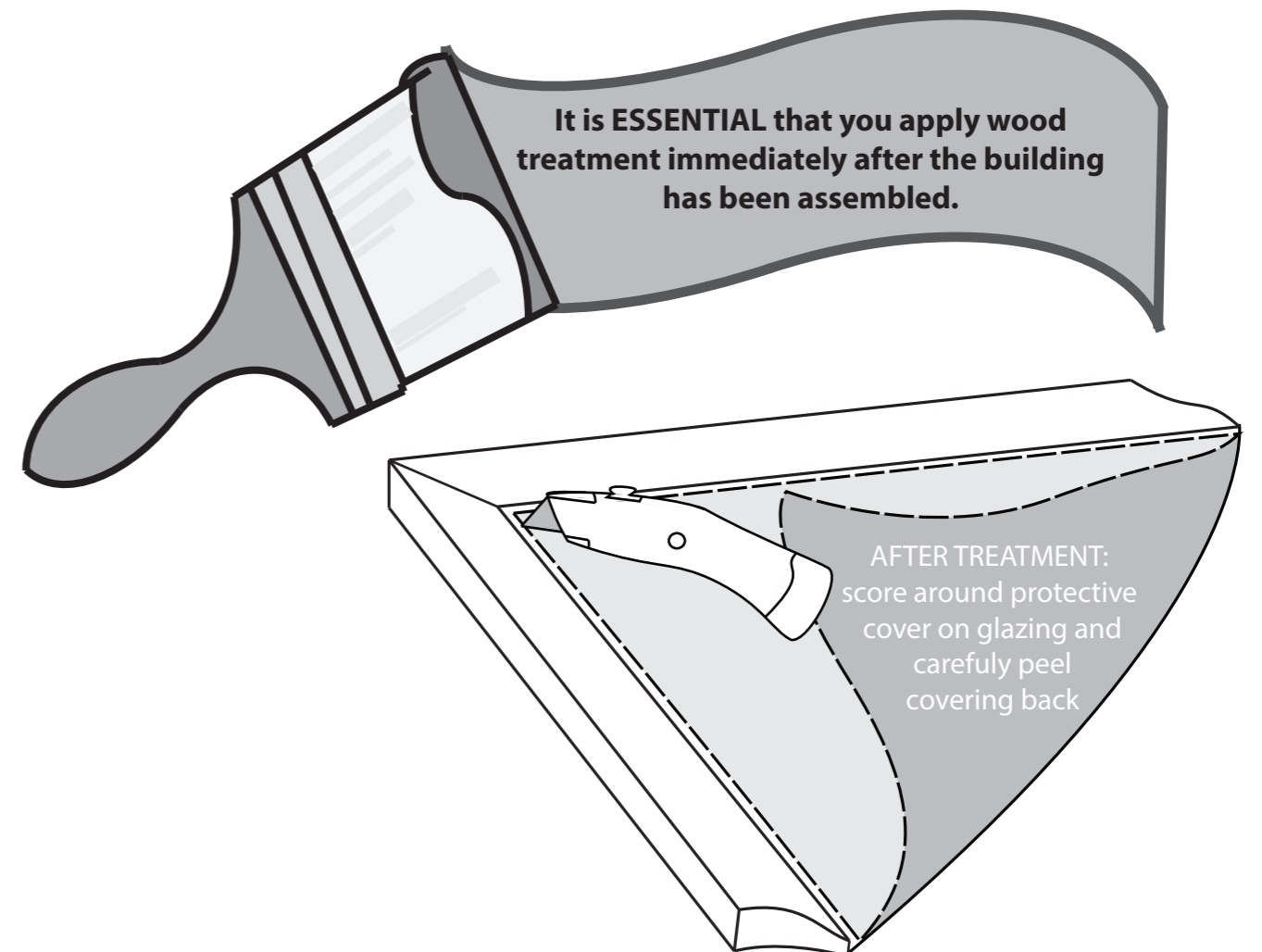

**AFTER TREATMENT:**  
score around protective cover on glazing and carefully peel covering back