

General Instructions

Please retain product label and instructions for future reference

03DTSHPN1208FGC32TWSA-V1

DIP TREATED SHIPLAP PENT 12FT X 8FT FULLY GLAZED CONCENTINA 3 2 TALL WINDOW

BEFORE YOU START PLEASE READ INSTRUCTIONS CAREFULLY

- Check the pack and make sure you have all the parts listed.
- When you are ready to start, make sure you have the right tools at hand (not supplied) including a Phillips screwdriver, Stanley knife, Wood saw, Step ladder, Hammer and a Drill with 2mm bit.
- Ensure there is plenty of space and a clean dry area for assembly.

LOCATION FOR YOUR GARDEN BUILDING

A minimum of 60cm should be left around the perimeter of your garden building to allow access for maintenance, annual treatment and to allow air flow around the building.

Where possible you should avoid placing your garden building underneath large trees to prevent the tree causing damage to the building.

TIMBER

As with all natural materials, timber can be affected during various weather conditions. For the duration of heavy or extended periods of rain, swelling of the wood panels may occur. Warping of the wood may also occur during excessive dry spells due to an interior moisture loss. Unfortunately, these processes cannot be avoided but can be helped. It is suggested that the outdoor building is sprayed with water during extended periods of warm sunshine and sheltered as much as possible during rain or snow.

Once your garden building has been installed it will need to be treated as soon as possible and annually to prevent the timber from deteriorating and to waterproof it. This is required to maintain the anti-rot guarantee.

- Dip Treated buildings - Require a preservative treatment to protect against rot and decay and a waterproof treatment to prevent water ingress
- Pressure Treated buildings - Require a waterproof treatment to prevent water ingress
- Log Cabins - Are supplied untreated and require a preservative and waterproofing treatment.

BUILDING A BASE

When thinking about where the building and base is going to be constructed: Ensure that there will be access to all sides for maintenance work and annual treatment.

Ensure the base is level and is built on firm ground, to prevent distortion. Refer to diagrams for the base dimensions, The base should be slightly smaller than the external measurement of the building, i.e. The cladding should overlap the base, creating a run off for water. It is also recommended that the floor be at least 25mm above the surrounding ground level to avoid flooding.

TYPES OF BASE

- Concrete 75mm laid on top of 75mm hard-core.
- Slabs laid on 50mm of sharp sand.

Whilst all products manufactured are made to the highest standards of Safety and in the case of childrens products independently tested to EN71 level, we cannot accept responsibility for your safety whilst erecting or using this product.



x2

All buildings should be erected by two adults



Winter = High Moisture = Expansion
Summer = Low Moisture = Contraction



2mm Drill bit

For ease of assembly, you **MUST** pilot drill all screw holes and ensure all screw heads are countersunk.



CAUTION

Every effort has been made during the manufacturing process to eliminate the prospect of splinters on rough surfaces of the timber. You are strongly advised to wear gloves when working with or handling rough sawn timber.



For ease of assembly, you will need a tape measure to check dimensions of components.

Screws & Nails



Measure overall length

Bolts



Measure under the head

To identify the fixings required for each step use a measuring tape.

Protim Aquatan T5 (621)

Your building has been dip treated with **Aquatan**.

Aquatan is a water-based concentrate which is diluted with water, the building as been treated by the correct application of Aquatan solution and then allowed to dry.

Aquatan is a decorative finish to colour the wood, which is applied industrially to timber fence panels and garden buildings.

Aquatan undiluted contains: boric acid, sodium hydroxide 32% solution, aqueous mixture of sodium dioctyl sulphosuccinat and alcohols: 2, 4, 6-trichlorophenol.



REGISTER FOR YOUR
ANTI-ROT
GUARANTEE TODAY

PLEASE SCAN HERE:



For assistance please contact customer care on: 01636 821215

Mercia Garden Products Limited,
Sutton On Trent,
Newark,
Nottinghamshire,
NG23 6QN

www.merciagardenproducts.co.uk



03DTSHPN1208FGC32TWSA-V1

Please retain product label and instructions for future reference

Overall Dimensions:

Width = 3618mm
Depth = 2471mm
Height = 2162mm



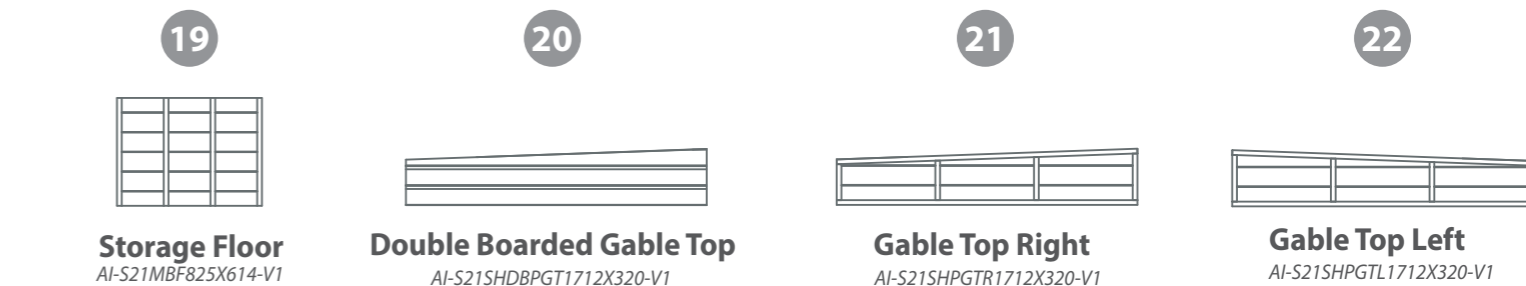
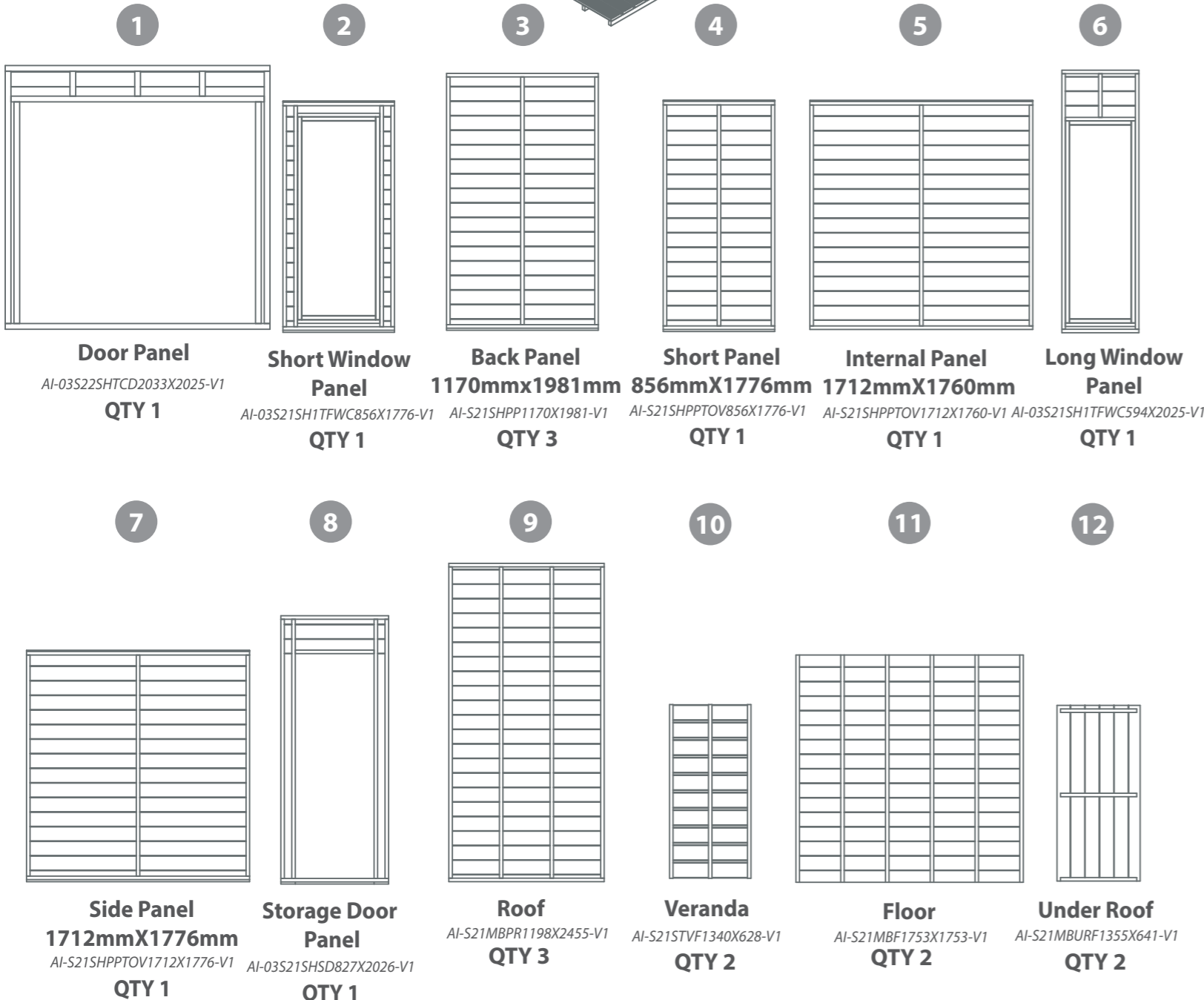
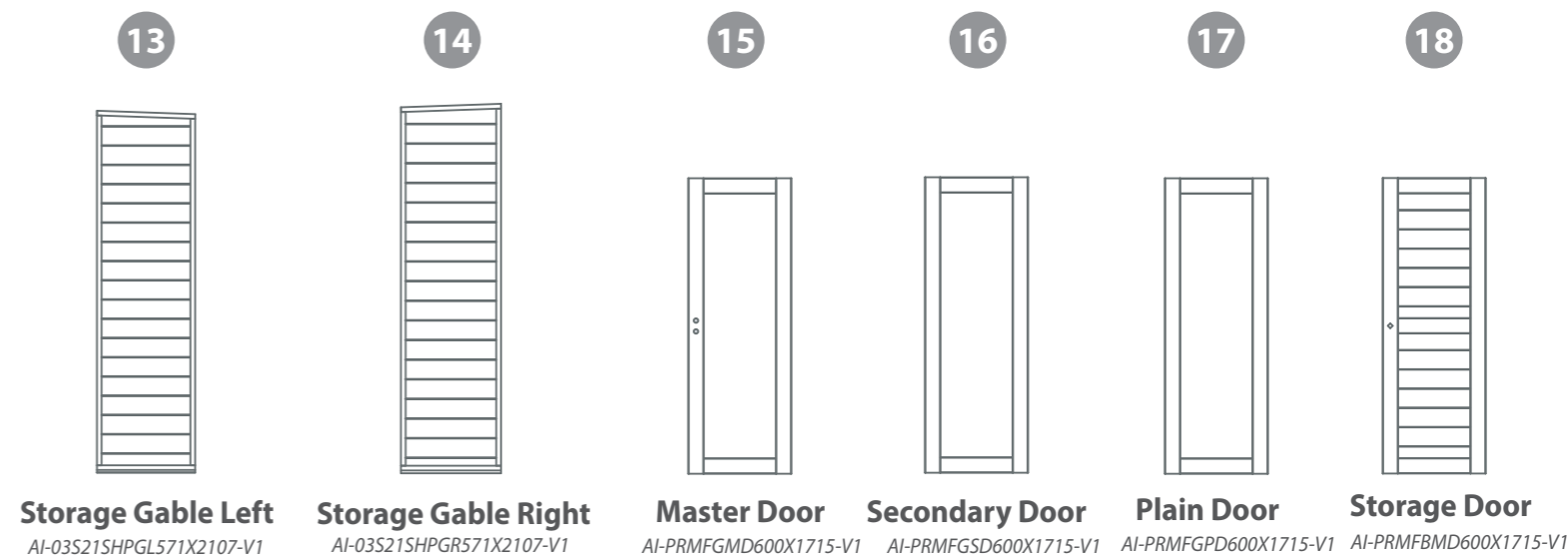
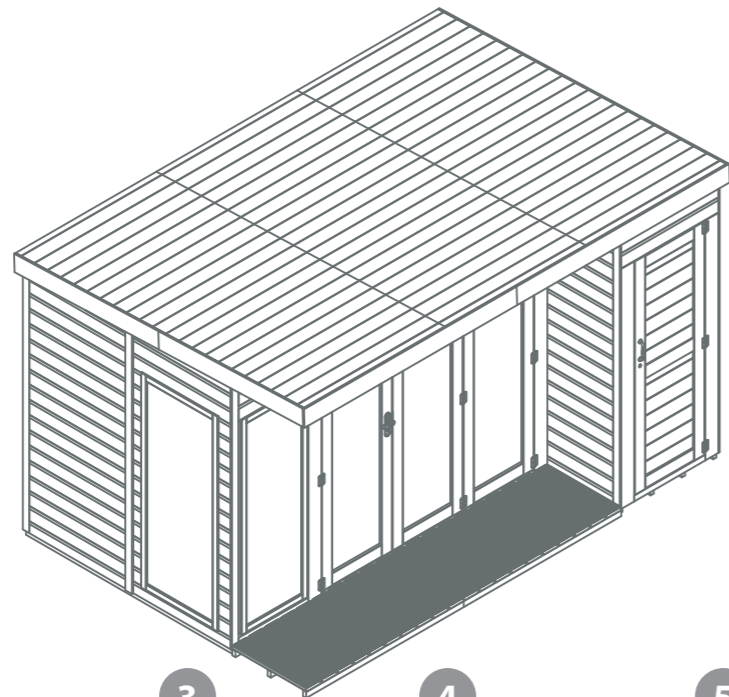

Base Dimensions:

Width = 3517mm
Depth = 2395 mm





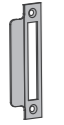



Fixing Kit continues on P3

Fixing kit cont..

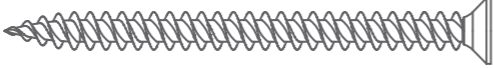
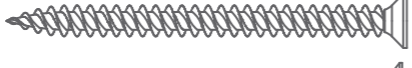
- 41  **Mortice Lock QTY 1**
PI-07-0017
- 42  **Butt Hinge QTY 12**
PI-07-0066
- 43  **Key Plate QTY 1**
PI-07-0017
- 44  **Turn Button QTY 4**
PI-07-0034

Nail Bag

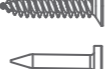
There may be extra screws present in the nail bag

-  **70mm Screw x 9**
-  **50mm Screw x 136**
-  **40mm Screw x 8**
-  **30mm Screw x 139**
-  **25mm Screw x 18**
-  **10mm Screw x 16**
-  **Felt Tacks x 150**

This building can be built with the shed on the LEFT hand side. Follow the same steps but be aware to position panels to the opposite side.

Step 2

Parts Needed - No. 23 QTY 3

Secure the floor (**No. 11**) to the Floor Blocks (**No. 23**) using 2x30mm screws per Floor Block.

6x30mm Screws



IMPORTANT: Pre-drill before fixing screws.

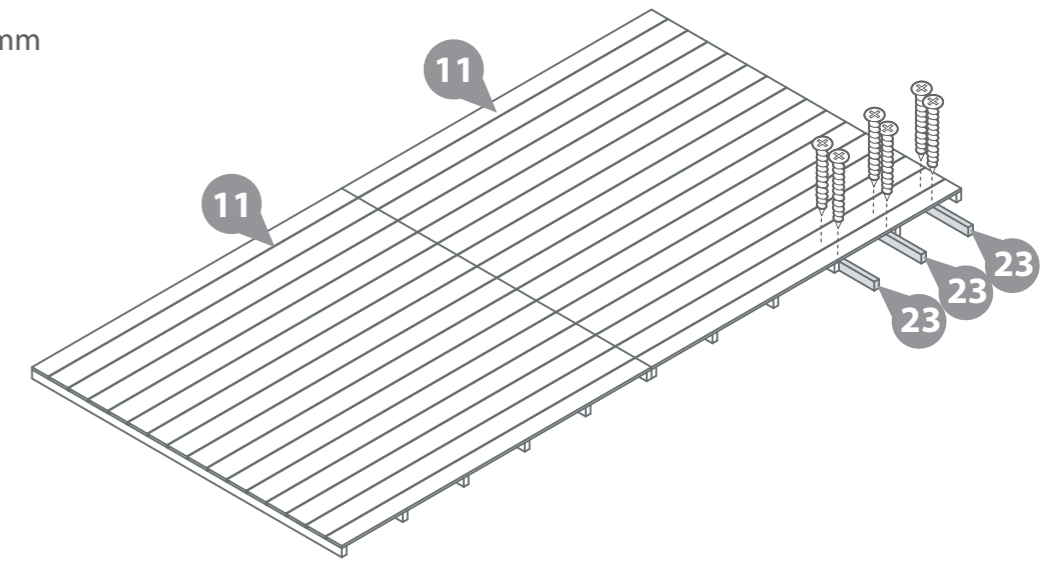

Pre Assembly

Before assembling remove the transportation blocks from the bottom of each panel.

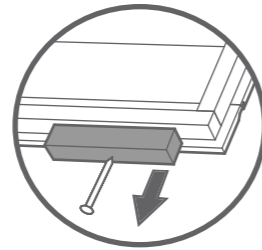

This building can be built with the shed on the LEFT hand side. Follow the same steps but be aware to position panels to the opposite side.

Step 1

Parts needed - No. 11 QTY 2

Place floors (**No. 11**) on a firm and level base, ensure base has suitable drainage free from areas where standing water can collect. (See front page on base requirements). Fix the two floor panels together as shown using 50mm screws at an angle and alternate the positions.

10x50mm Screws

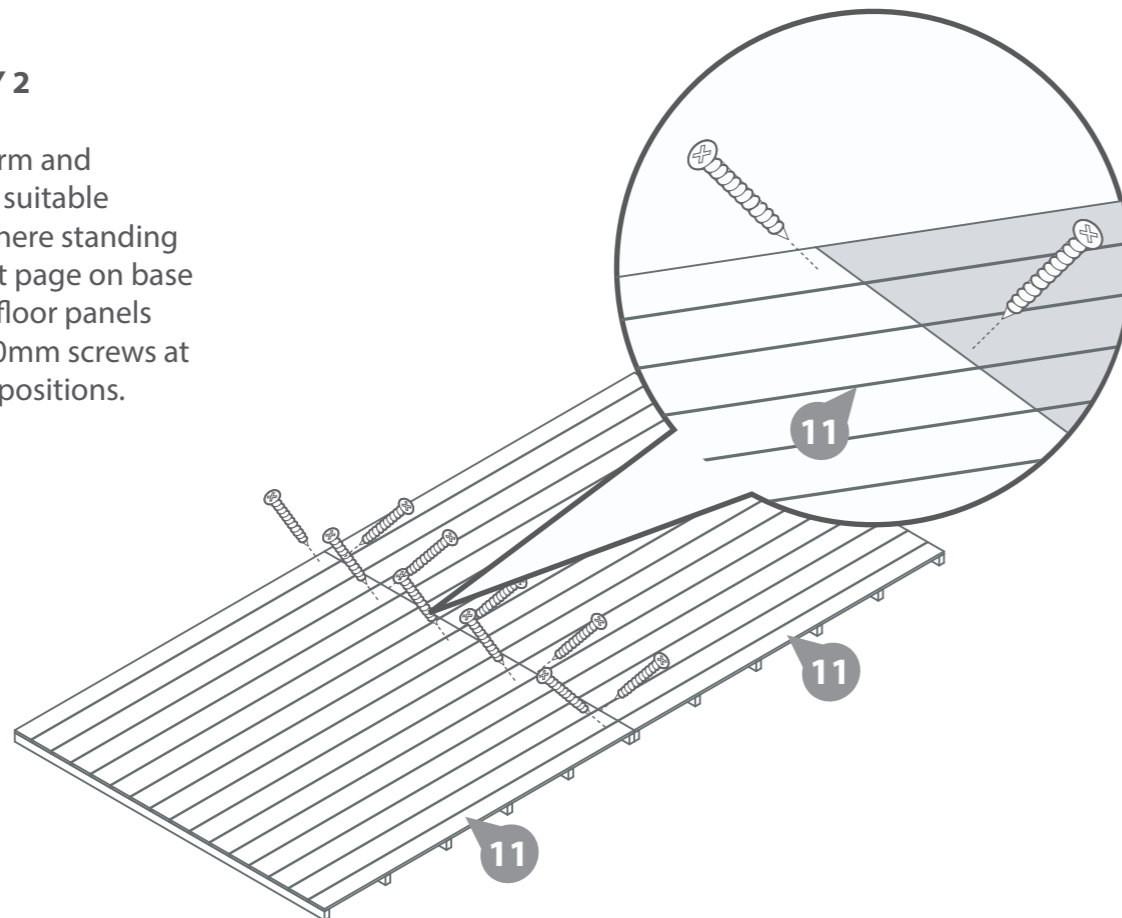
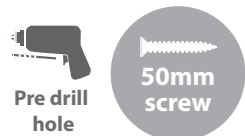

IMPORTANT: Pre-drill before fixing screws.

Step 3

Parts Needed - No. 19 QTY 1

Secure the Storage Floor (**No. 19**) to the assembly from Step 2, using 2x30mm screws per Floor Block.

6x30mm Screws



IMPORTANT: Pre-drill before fixing screws.

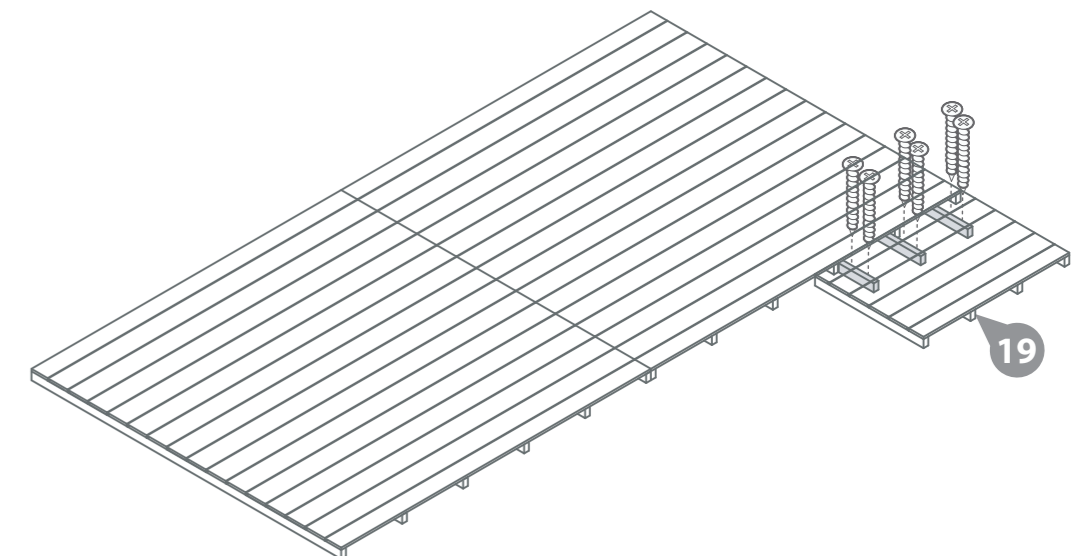

Step 4

Parts Needed - No. 3 QTY 1
- No. 4 QTY 1

Fix the side of the short panel (No. 4) against the framing of the back panel (No. 3) with 3x50mm screws as shown in diagram.

Do not secure the building to the Floor until the roof is fitted.

3x50mm Screws

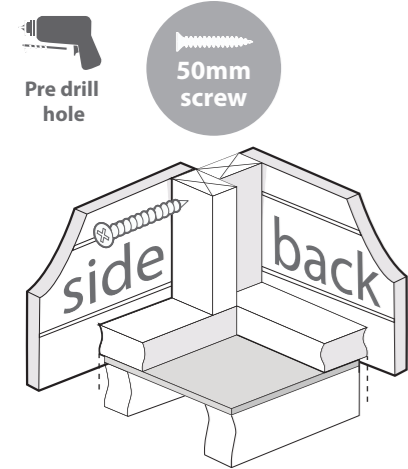

IMPORTANT: Pre-drill before fixing screws.

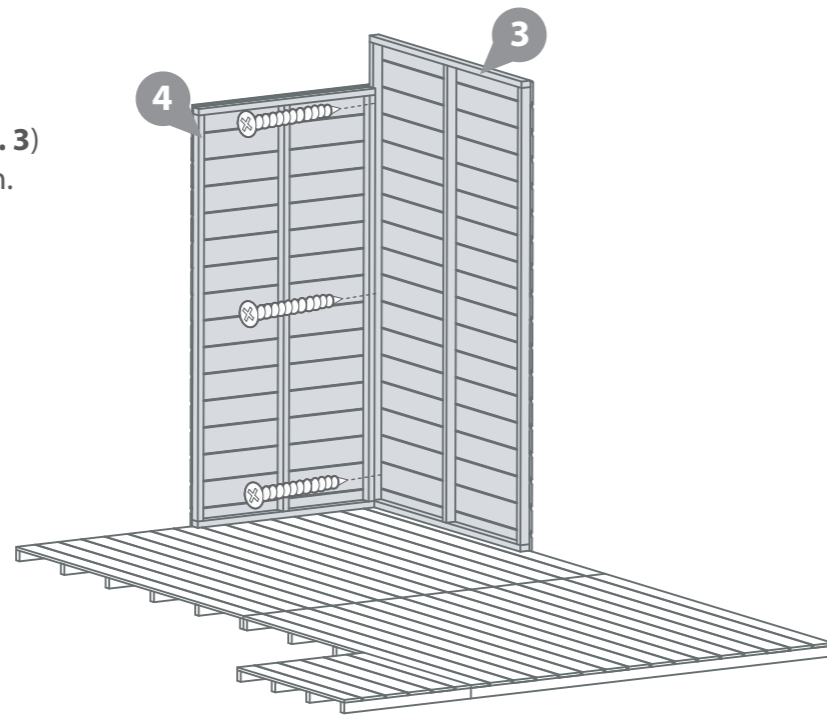

Step 6

Parts Needed - No. 6 QTY 1

Place the Long Window Panel (No. 6) onto the assembly next to the Short Window Panel (No. 2). Fix with 3x70mm screws as shown in diagram externally. Make sure that the Framing is flush with other Framing, not the cladding.

Do not secure the building to the Floor until the roof is fitted.

3x70mm Screws

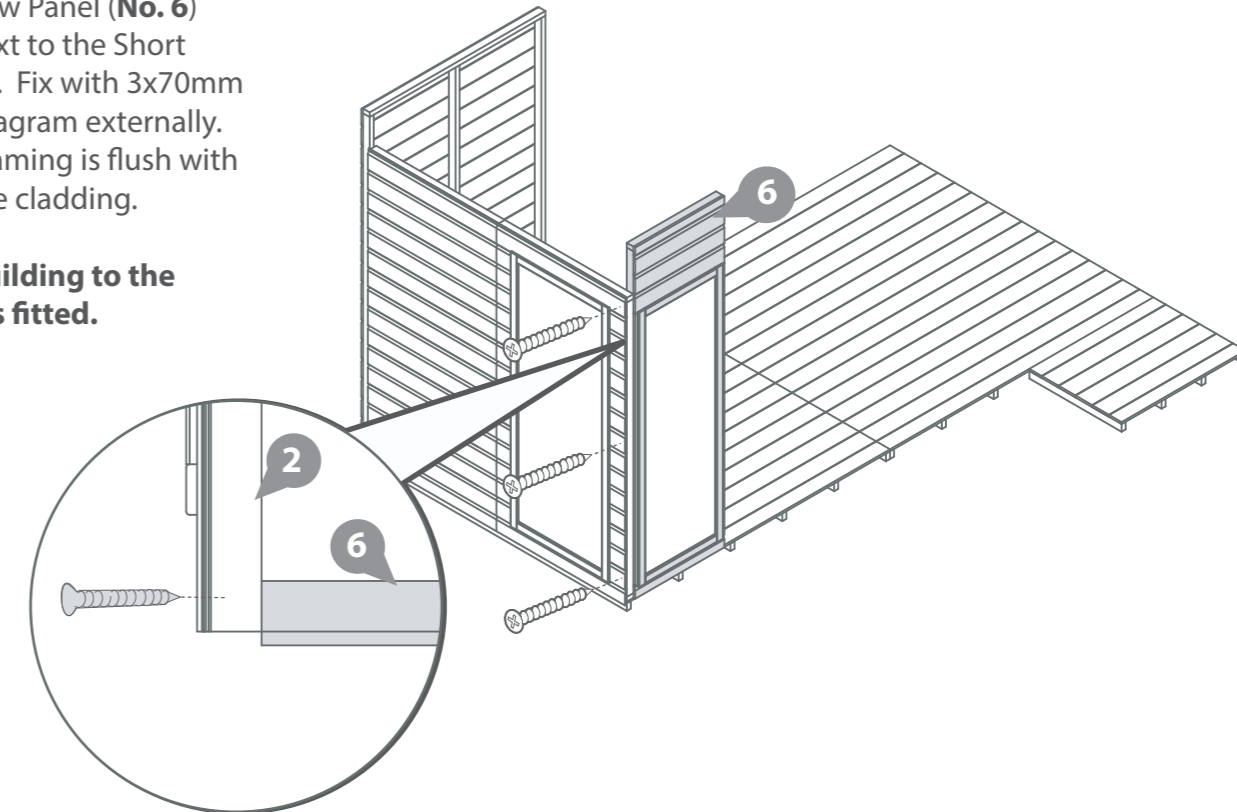

Step 5

Parts Needed - No. 2 QTY 1

Fix the side of the Short Panel (No. 4) against the side of the Short Window Panel (No. 2) with 4x50mm screws as shown in diagram.

Do not secure the building to the Floor until the roof is fitted.

4x50mm Screws

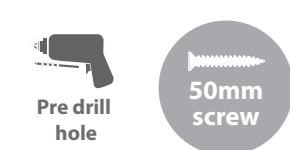

IMPORTANT: Pre-drill before fixing screws.

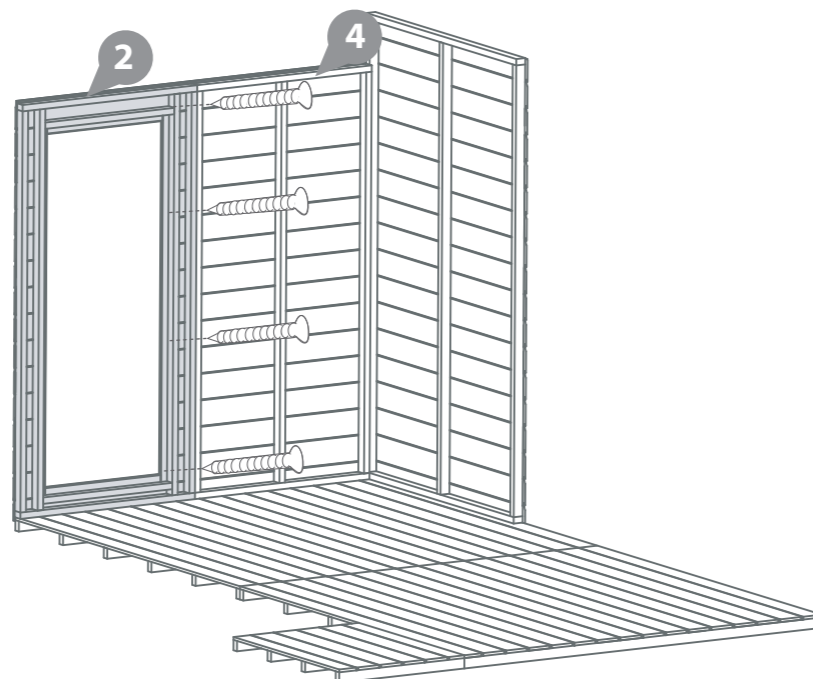

Step 7

Parts Needed - No. 3 QTY 2

Fix the side of the Back Panel (No. 3) against the side of the other Back Panel (No. 3) with 4x50mm screws as shown in diagram. Repeat this for the remaining Back Panel.

Do not secure the building to the Floor until the roof is fitted.

8x50mm Screws

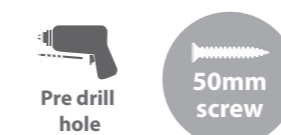

IMPORTANT: Pre-drill before fixing screws.

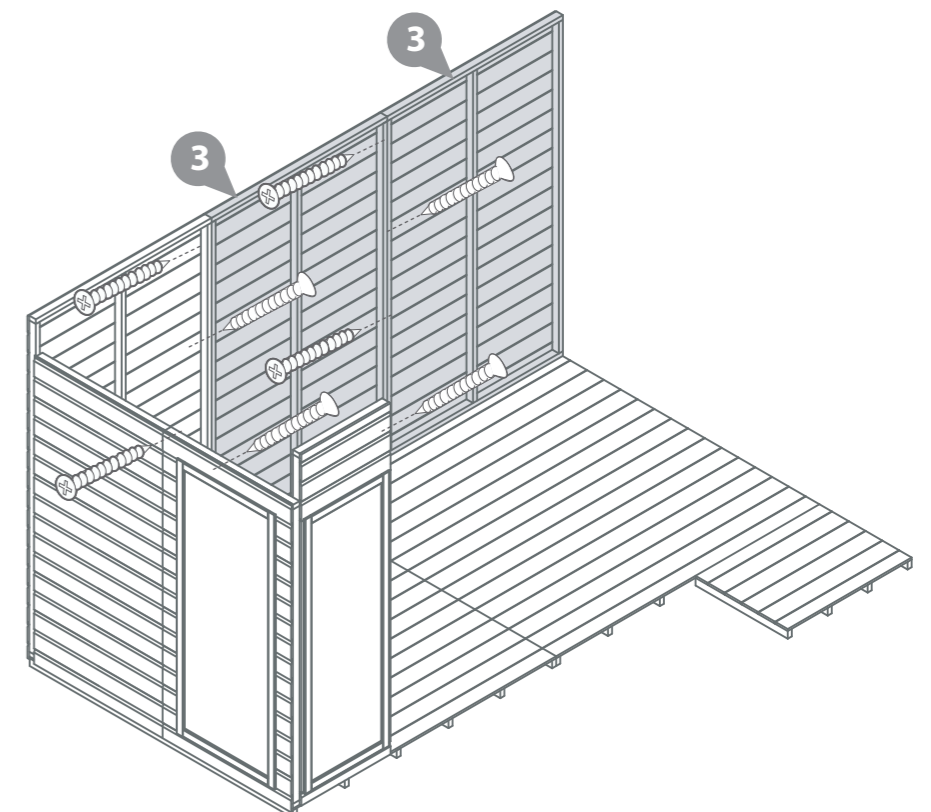

Step 8

Parts Needed - No. 1 QTY 1

Place the Door Panel (No. 1) onto the assembly next to the Long Window Panel (No. 6). Fix with 4x50mm screws as shown in diagram internally.

Do not secure the building to the Floor until the roof is fitted.

4x50mm Screws

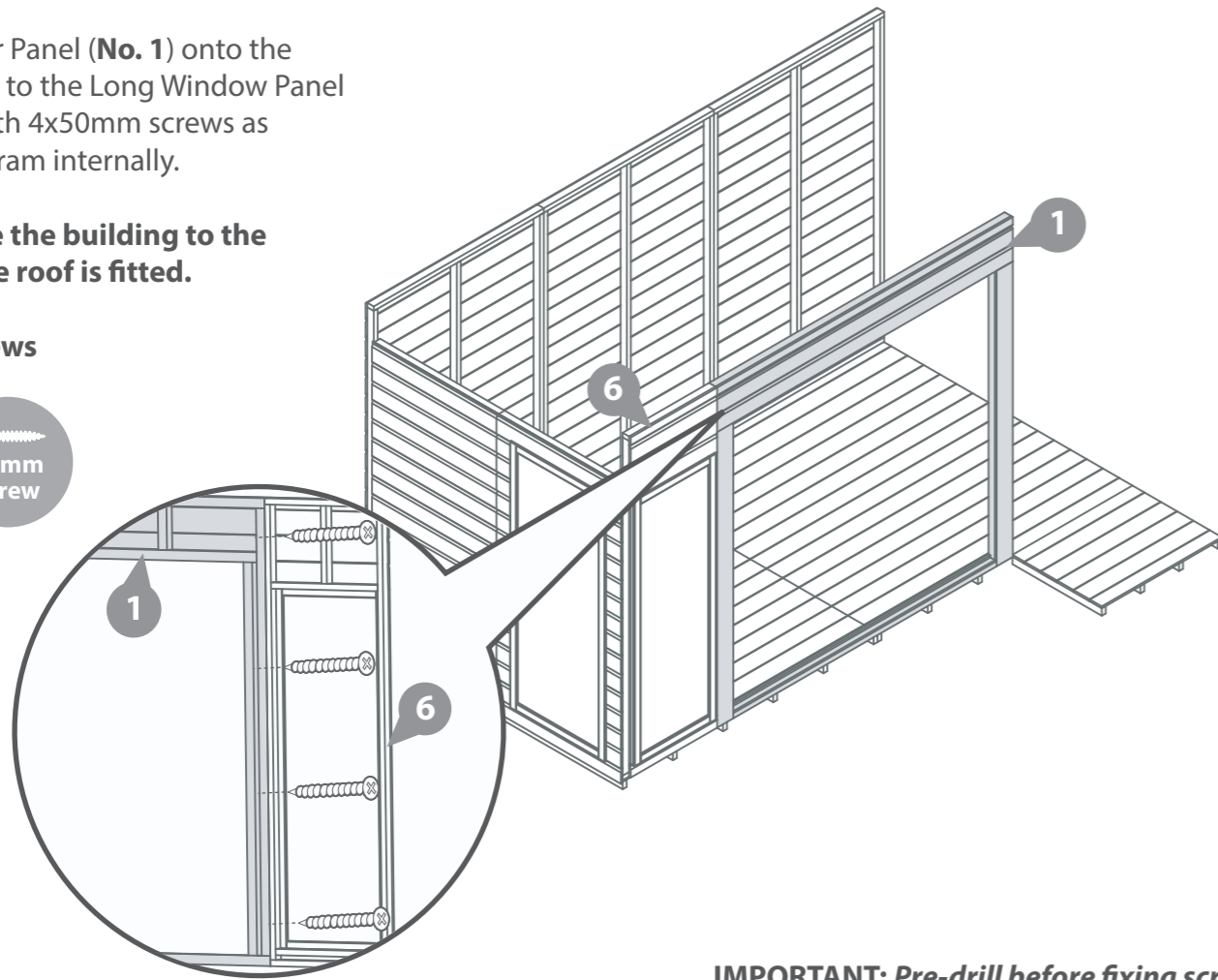

IMPORTANT: Pre-drill before fixing screws.

Step 10

Parts Needed - No. 21 QTY 1
- No. 22 QTY 1

Place the Gable Top Left/Right (No. 21/No. 22) upon the top of the side panels, slotting the groove of the boarding on the gable into the tongue of the side panel as shown and screw internally.

Fix with 4x50mm screws per gable top as shown in diagram.

8x50mm Screws

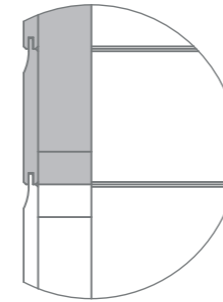
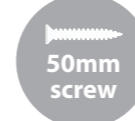

IMPORTANT: Pre-drill before fixing screws.

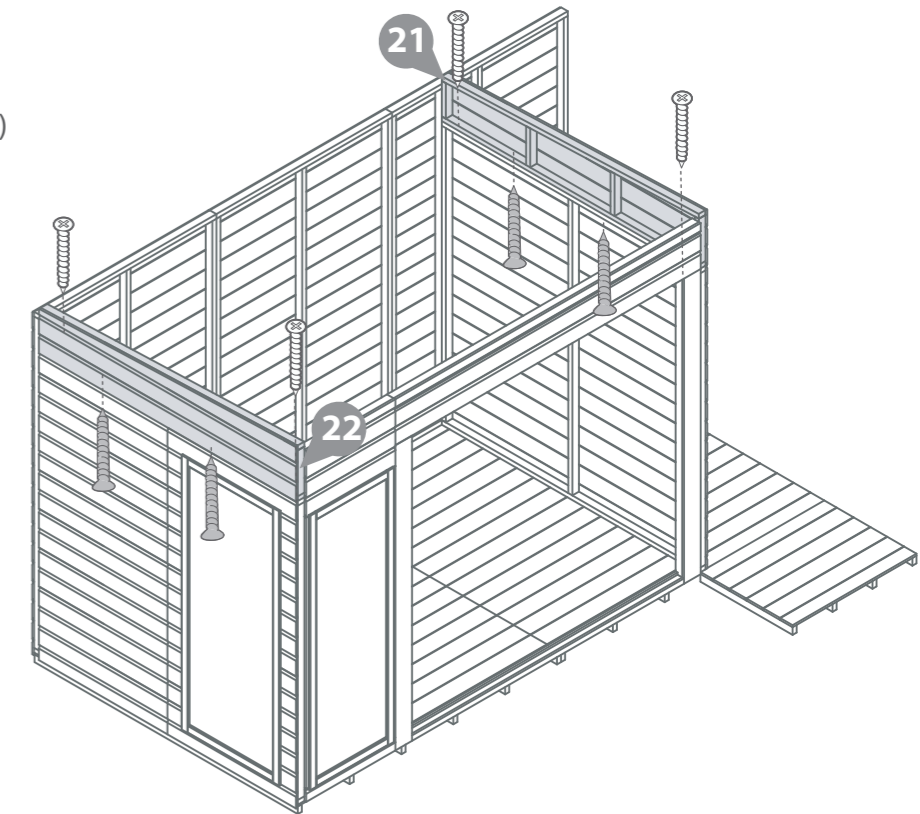

Step 9

Parts Needed - No. 5 QTY 1
- No. 33 QTY 1

Fix the side Internal Panel (No. 5) against the framing of the Door Panel (No. 1) with 3x70mm screws as shown in the diagram externally. Make sure that the Framing is flush with other Framing, not the cladding.

Then fix the Internal Panel Framing (No. 33) to the otherside of the Internal Panel (No. 5) with 3x50mm screws as shown in the diagram internally.

Do not secure the building to the Floor until the roof is fitted.

3x50mm Screws
3x70mm Screws

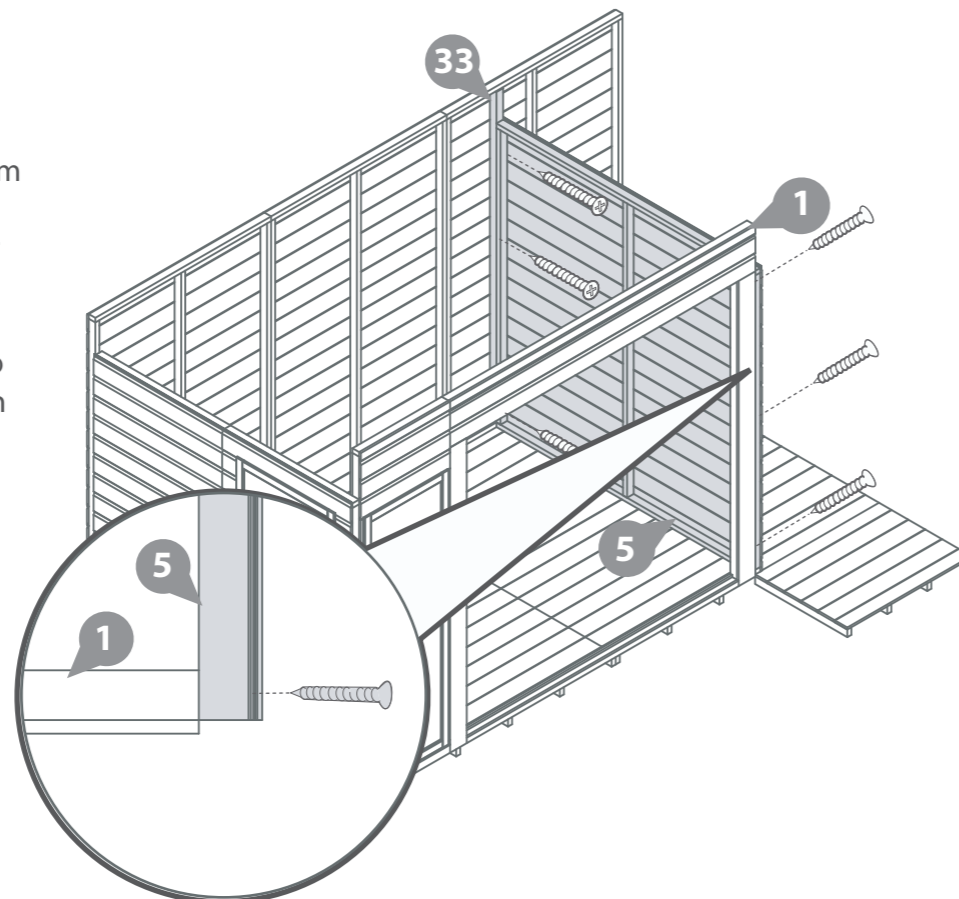

IMPORTANT: Pre-drill before fixing screws.

Step 11

Fix the edge of the Internal Panel Framing (No. 33) to the inside of the Back Panel (No. 3) externally with 4x50mm screws as shown in diagram.

Make sure that the panels are in a square position and use the Gable Top Right (No. 21) as a guide so that you fix the screws correctly in a straight line.

4x50mm Screws



50mm screw

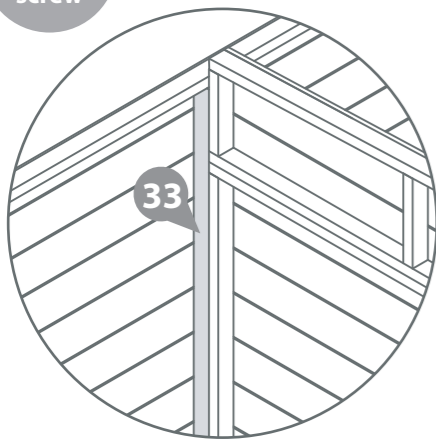

IMPORTANT: Pre-drill before fixing screws.

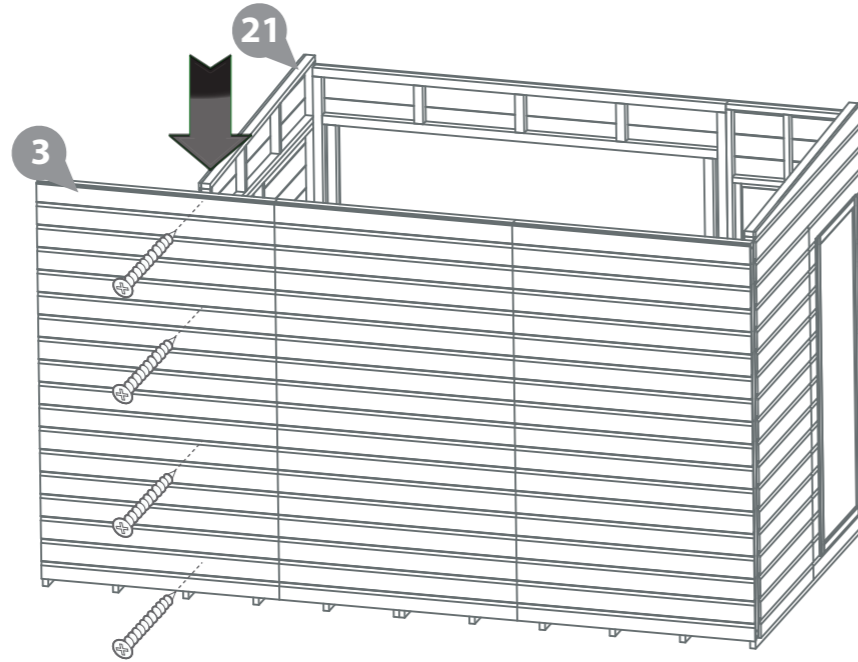

Step 13

Parts Needed - No. 20 QTY 1

Place the Double Boarded Gable Top (No. 20) on top of the Side Panel (No. 7) slotting the groove of the boarding on the gable into the tongue of the side panel as shown.

Fix with 4x50mm screws per gable top as shown in diagram.

4x50mm Screws



50mm screw

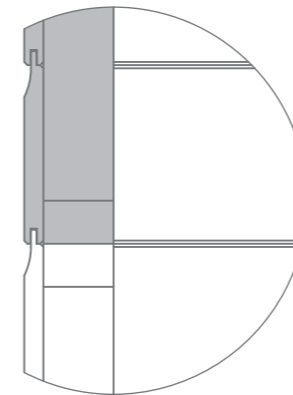

IMPORTANT: Pre-drill before fixing screws.

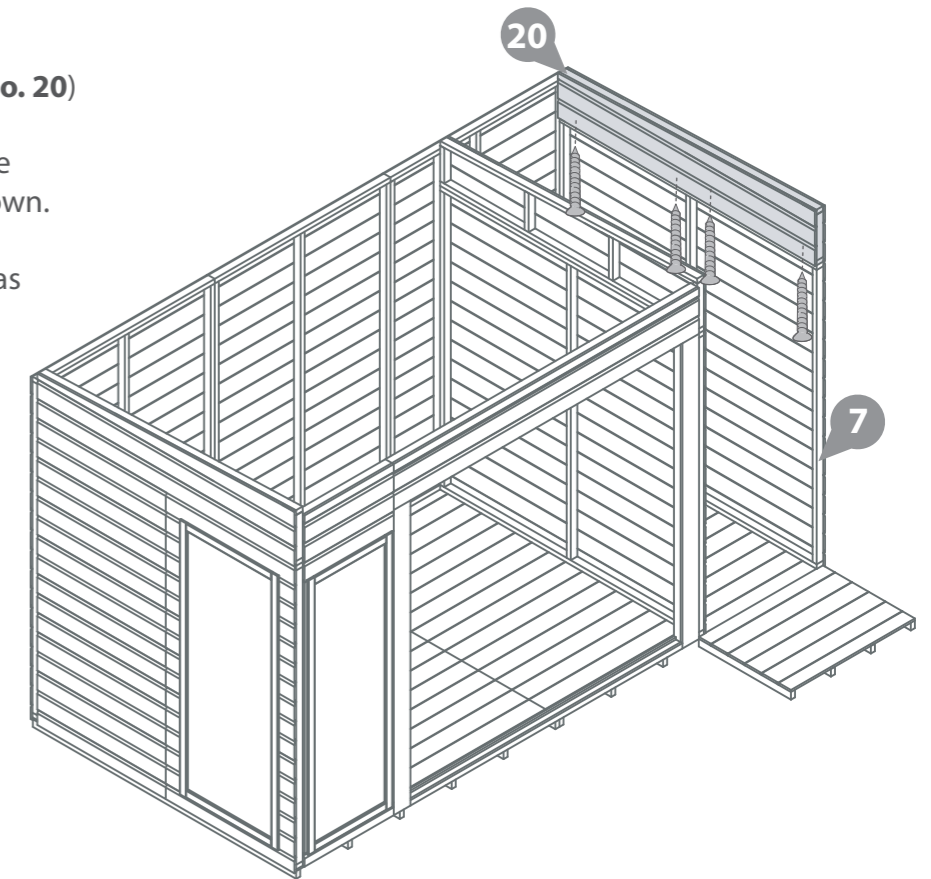

Step 12

Parts Needed - No. 7 QTY 1

Fix the side of the Side Panel (No. 7) against the framing of the Back Panel (No. 3) with 3x 50mm screws as shown in diagram.

Fix with 3x50mm screws as shown in diagram.

Do not secure the building to the Floor until the roof is fitted.

3x50mm Screws



50mm screw

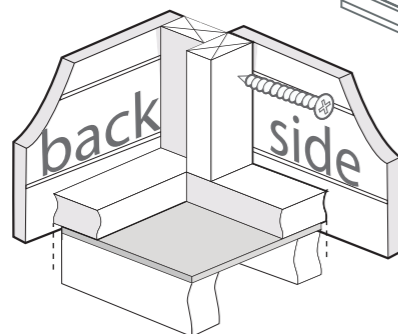

IMPORTANT: Pre-drill before fixing screws.

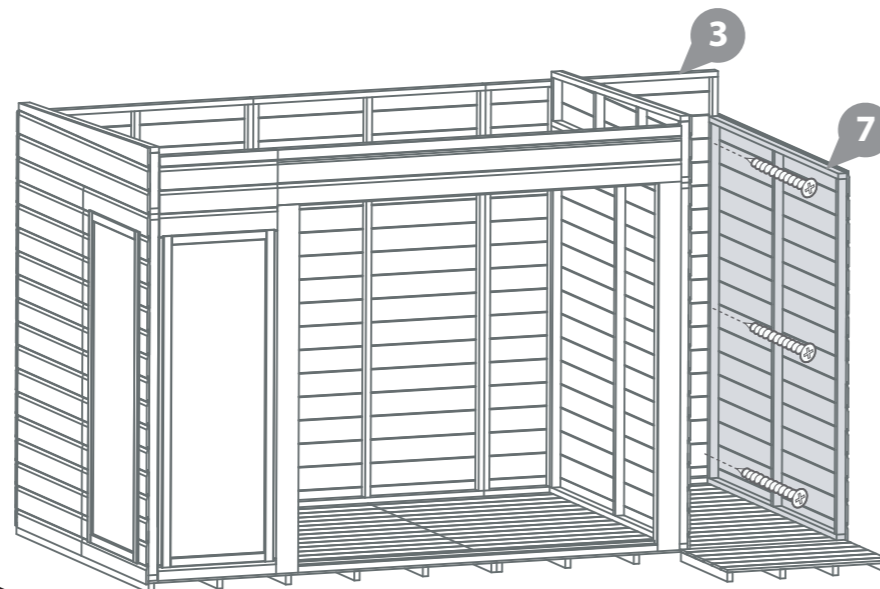

Step 14

Parts Needed - No. 13 QTY 1
- No. 14 QTY 1

Place the Storage Gable Sides Left/Right (No. 13/14) against the sides of the Internal (No. 5) and Side Panel (No. 7) with the boarding facing outwards as shown.

Fix with 4x50mm screws per gable as shown in diagram.

Do not secure the building to the Floor until the roof is fitted.

8x50mm Screws



50mm screw

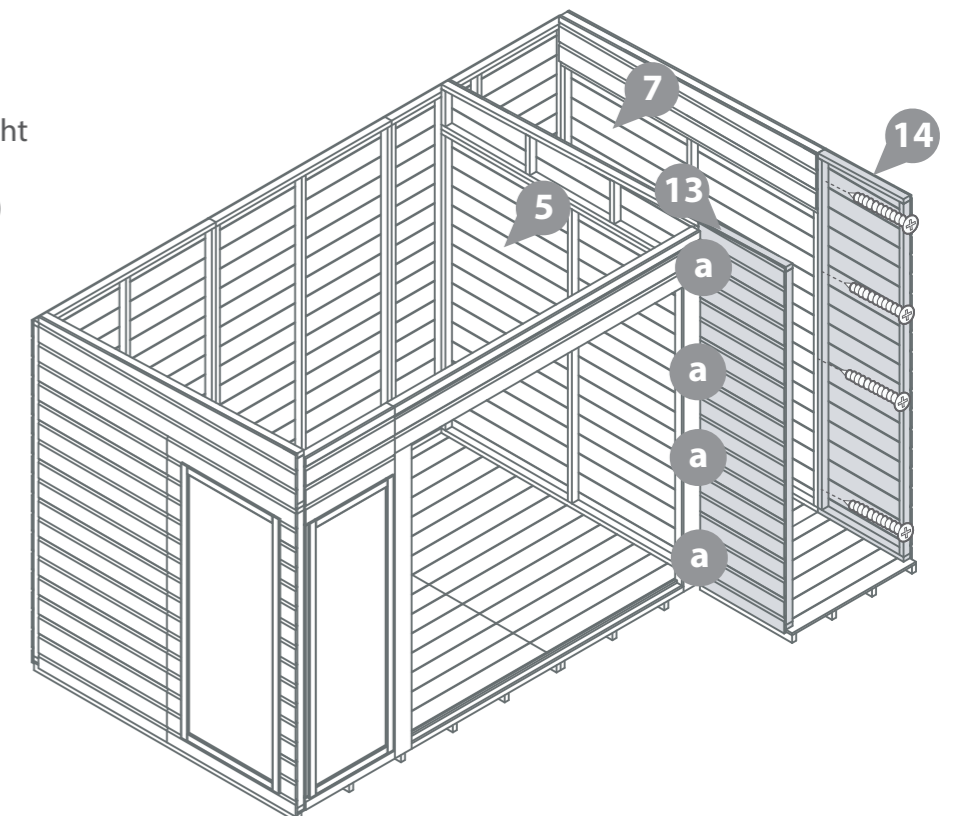

IMPORTANT: Pre-drill before fixing screws.

Step 15

Parts Needed - No. 17 QTY 1
- No. 42 QTY 3

Attach the Plain Door (No.17) to the door panel using 3x butt hinges (No.42) per door.

18x30mm Screws

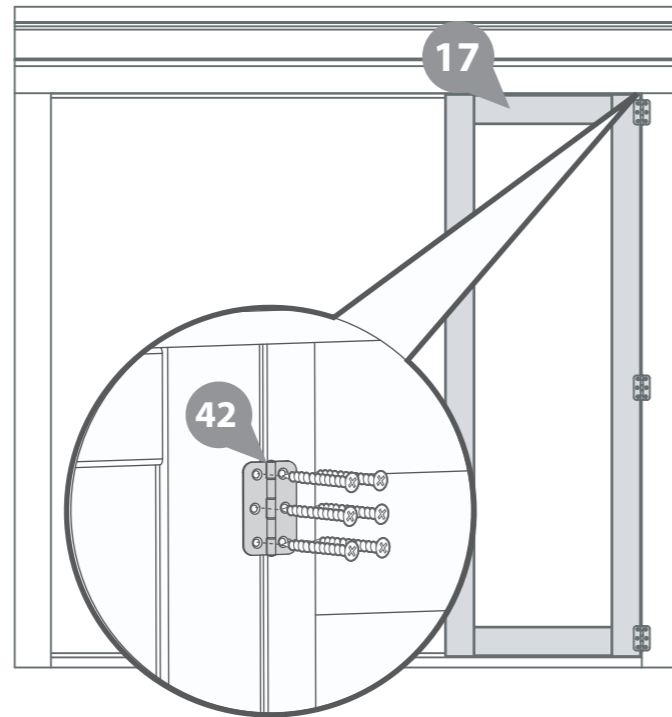
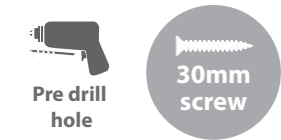

IMPORTANT: Pre-drill before fixing screws.

Step 17

Parts Needed - No. 32 QTY 2
- No. 37 QTY 2
- No. 40 QTY 4
- No. 41 QTY 1
- No. 43 QTY 1

Fit the mortice lock (No. 41) into the recess and fix in place with the screws provided. Fit the key plate (No. 43) to the opposite door using the 4X30mm screws provided.

Fix door handles (No. 37) using 8x30mm screws.

Fix the Door Trims (No. 32) to the plain (No. 17) and secondary door (No. 16), positioning the strip with a small overhang to the right hand door. Fit the barrel bolts (No. 40) to top and bottom of the door strips as shown in diagram. Use 4x10mm screws per barrel bolt.

Ensure doors open and close freely.

10x30mm Screws
16x10mm Screws



IMPORTANT: Pre-drill before fixing screws.

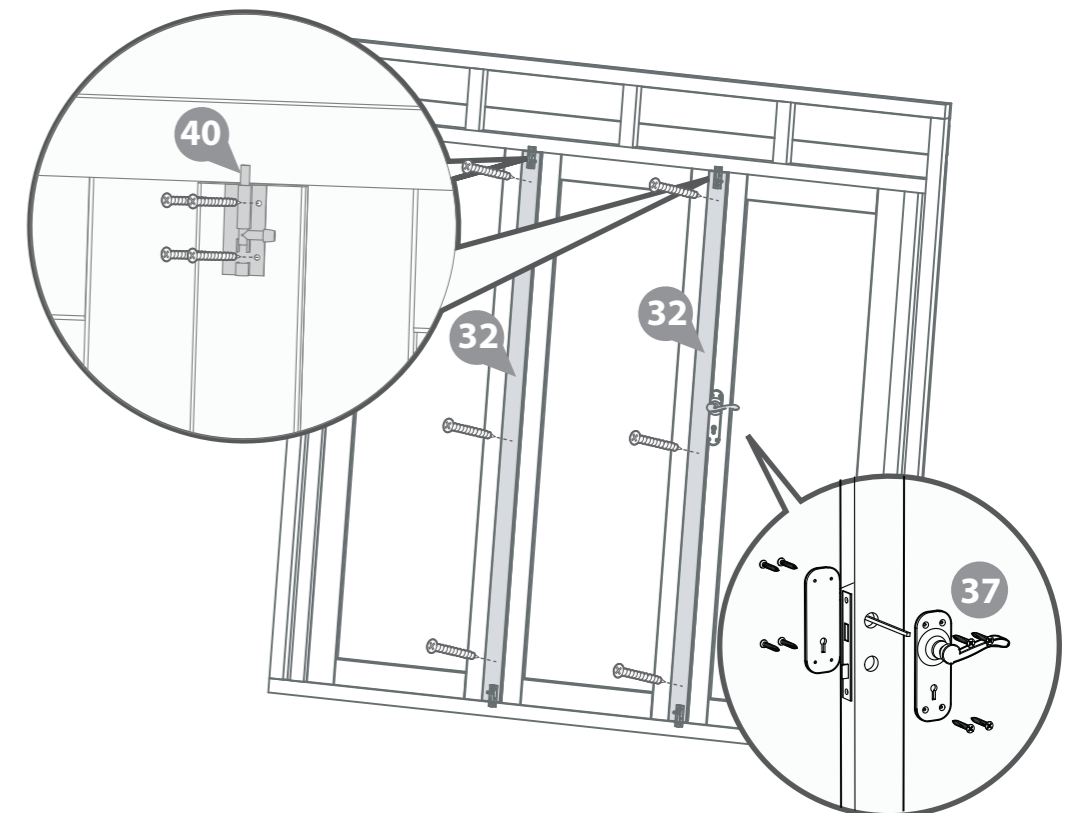
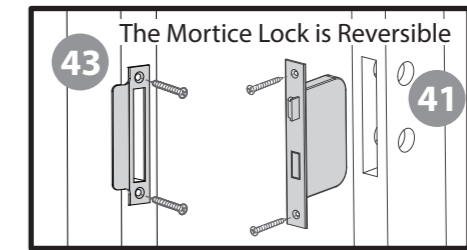

Step 16

Parts Needed - No. 15 QTY 1
- No. 16 QTY 1
- No. 42 QTY 6

Fix the master door (No.15) to the outside of the door framing and secondary door (No.16) to the attached plain doors with 3x butt hinges per door, using 6x30mm screws per hinge.

**Ensure the doors open freely, folding back into the building unrestricted.*

36x30mm Screws

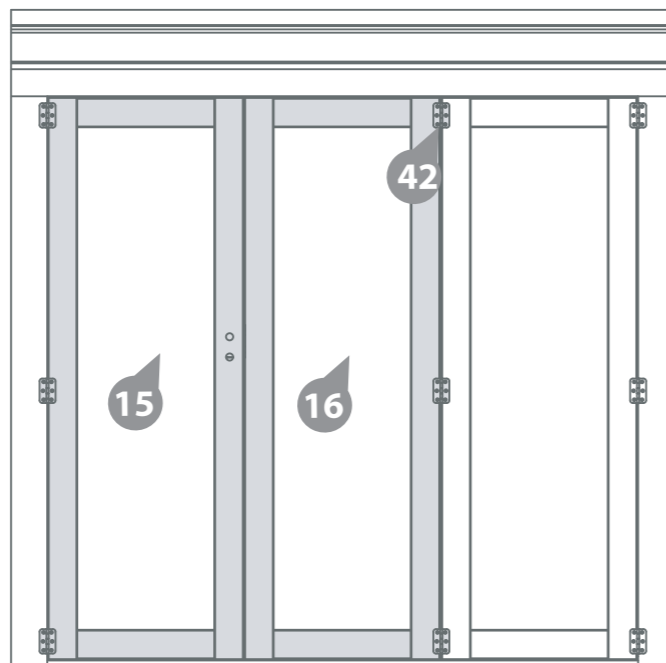

IMPORTANT: Pre-drill before fixing screws.

Step 18

Parts Needed - No. 8 QTY 1

Place the Storage Door panel (No. 8) against the end of the Storage Gable Sides (No. 13/14) and fix into position internally.

Fix with 4x50mm screws per side internally as shown in diagram.

Do not secure the building to the Floor until the roof is fitted.

8x50mm Screws

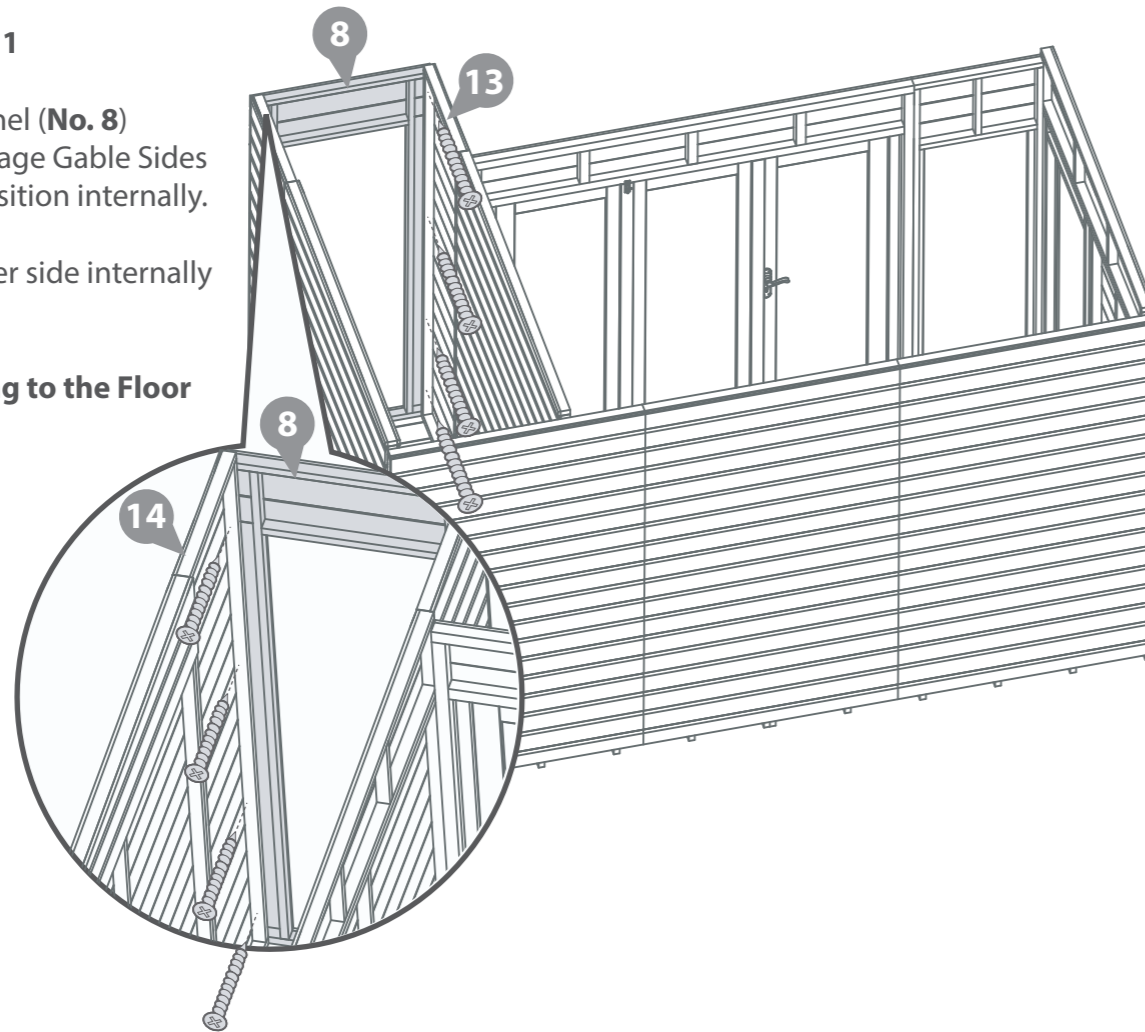

Step 19

Parts Needed - No. 18 QTY 1
- No. 42 QTY 3

Secure the 3x hinge (No. 42) to the storage door (No. 18) and the storage door panel (No. 8).

Do not secure the building to the Floor until the roof is fitted.

18x25mm Screws

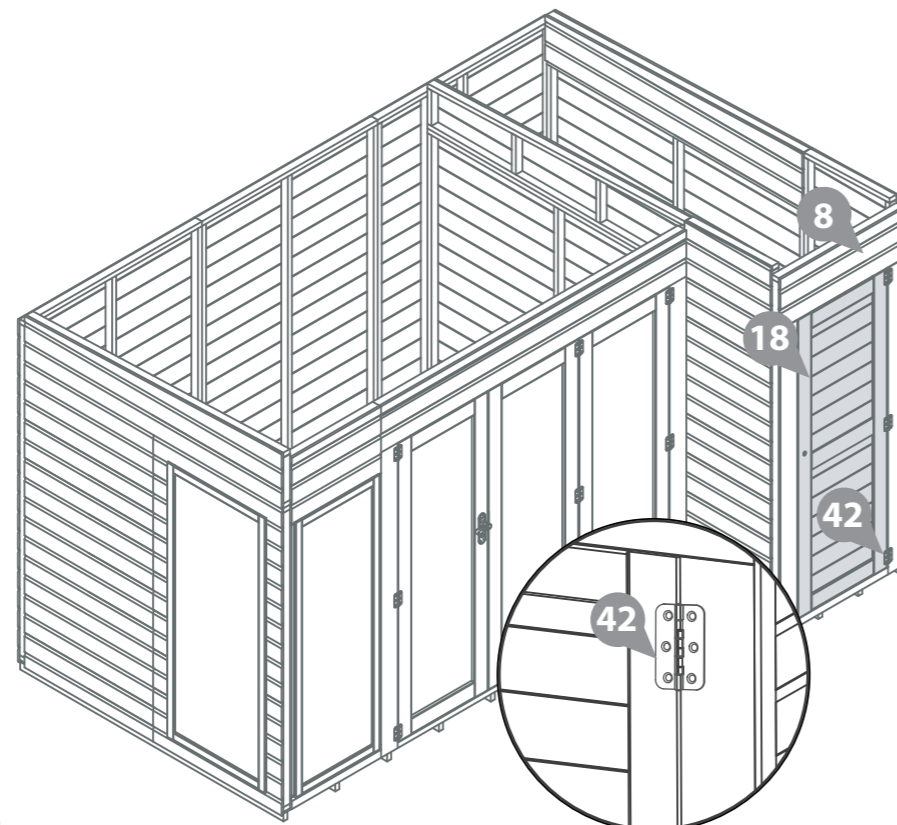

Storage Door hinges fitted on the right hand side of the door which means that your door will open on the left side.

IMPORTANT: Pre-drill before fixing screws.

Step 20

Parts Needed - No. 10 QTY 2

Lay the 2x Veranda (No. 10) face down, side by side and fix together with 3x70mm screws through the bearers as shown in the diagram, to secure the two Verandas together.

3x70mm Screws

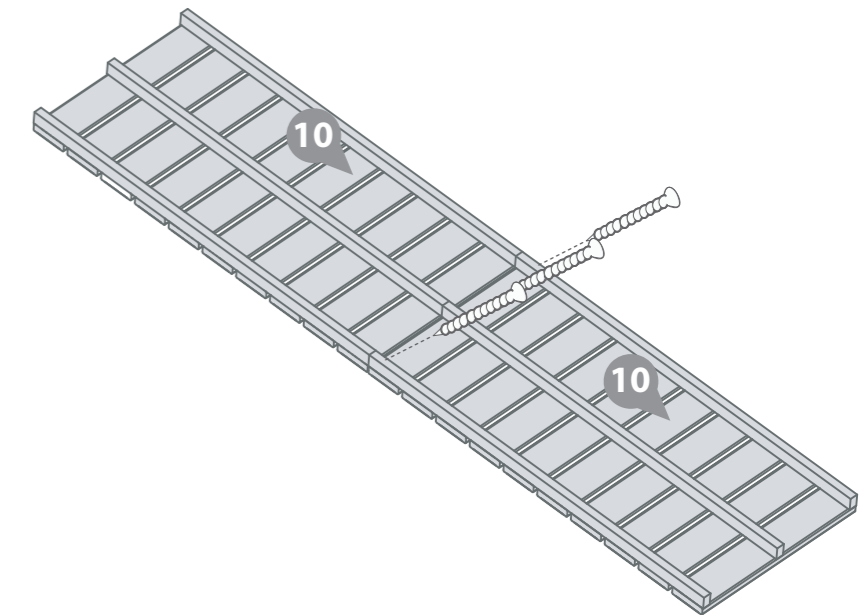

IMPORTANT: Pre-drill before fixing screws.

Step 21

Parts Needed - No. 10 QTY 2

Place the assembled Verandas (No. 10) flush to the building as shown to make sure the building is square.

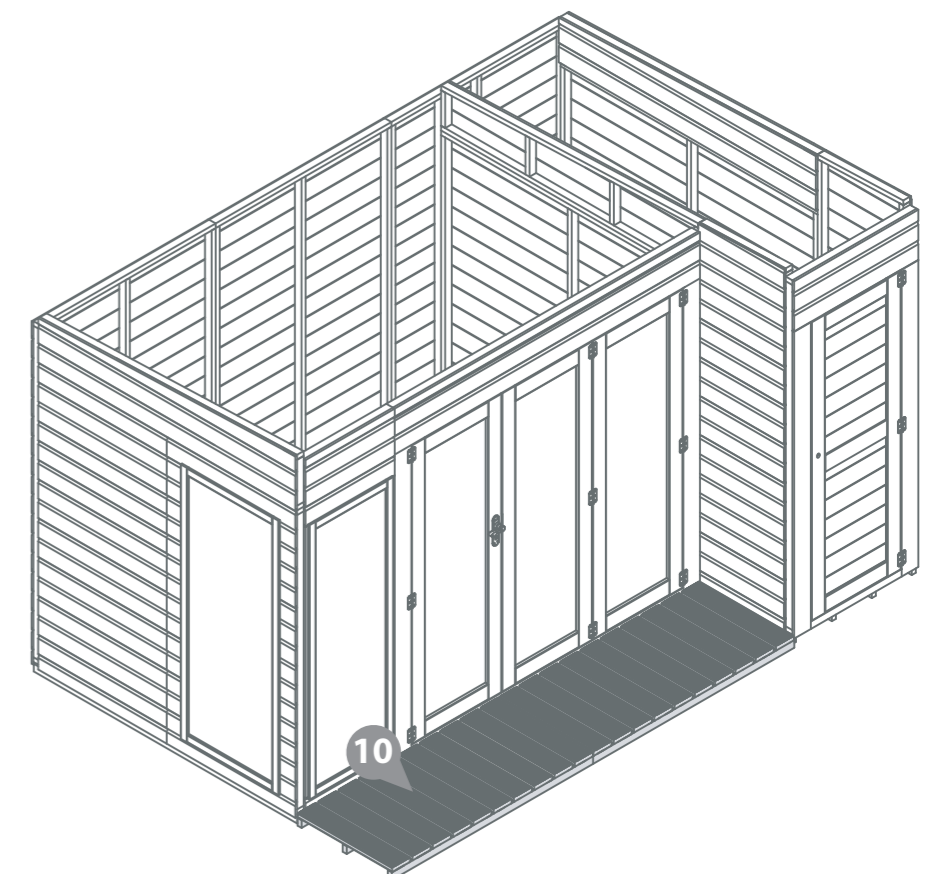

IMPORTANT: Pre-drill before fixing screws.

Step 22

Parts Needed - No. 9 QTY 3

Place the Roof Panels (No. 9) onto the top of the building. Align the 3 Roof Panels so they sit square before fixing into position.

Do not secure the building to the Floor until the roof is fitted.

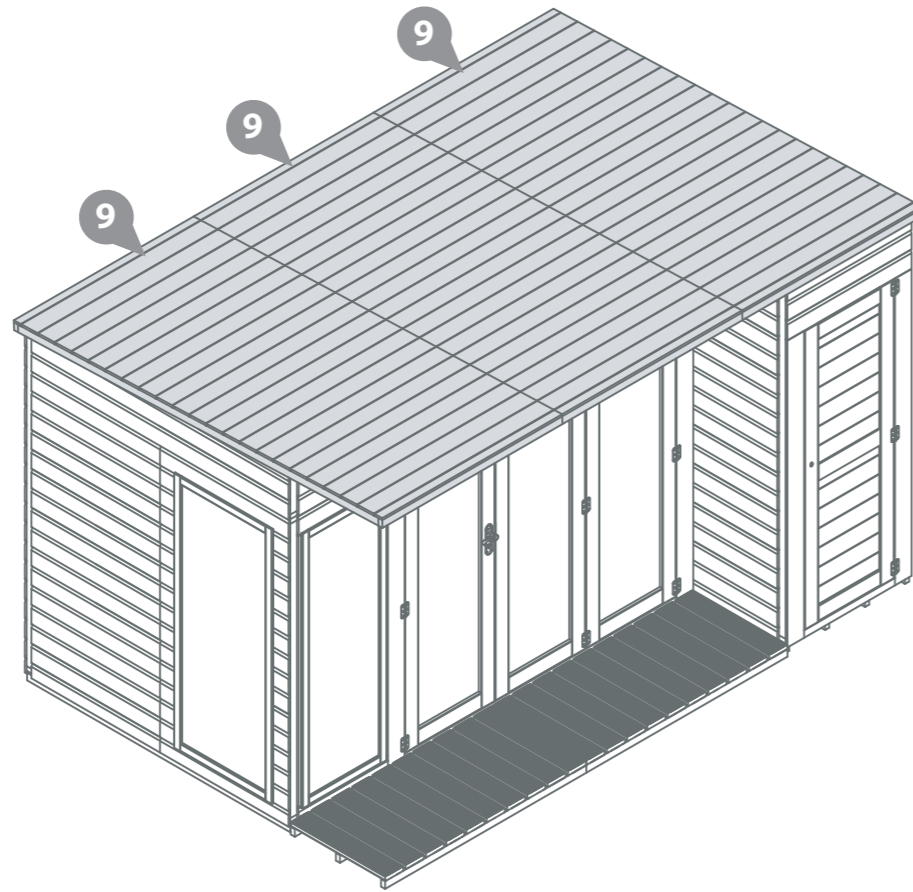

Step 24

Parts Needed - No. 12 QTY 2

Place the Under Roof Panels (No. 12) into position, making sure it is flush to the Door panel and Storage section.

Fix in place making sure to screw through the Roof framing.

14x30mm Screws

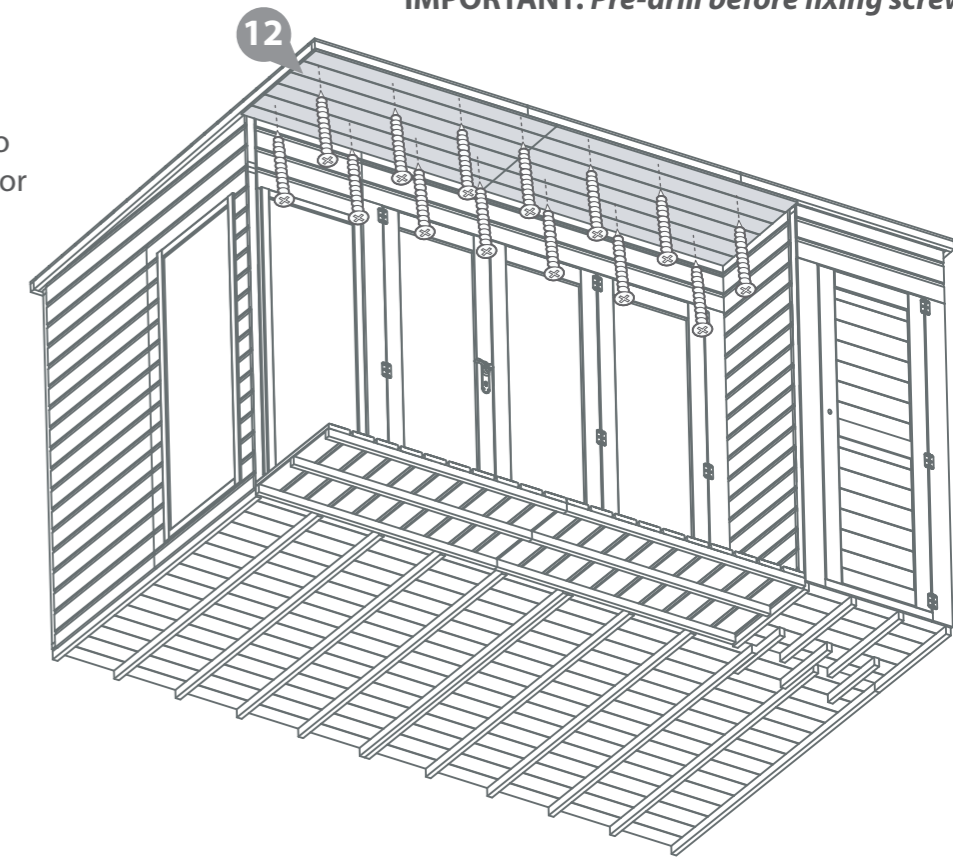

Step 23

Fix the three Roof panels together using 50mm offset from each other as shown in the diagram.

Do not secure the building to the Floor until the roof is fitted.

16x50mm Screws

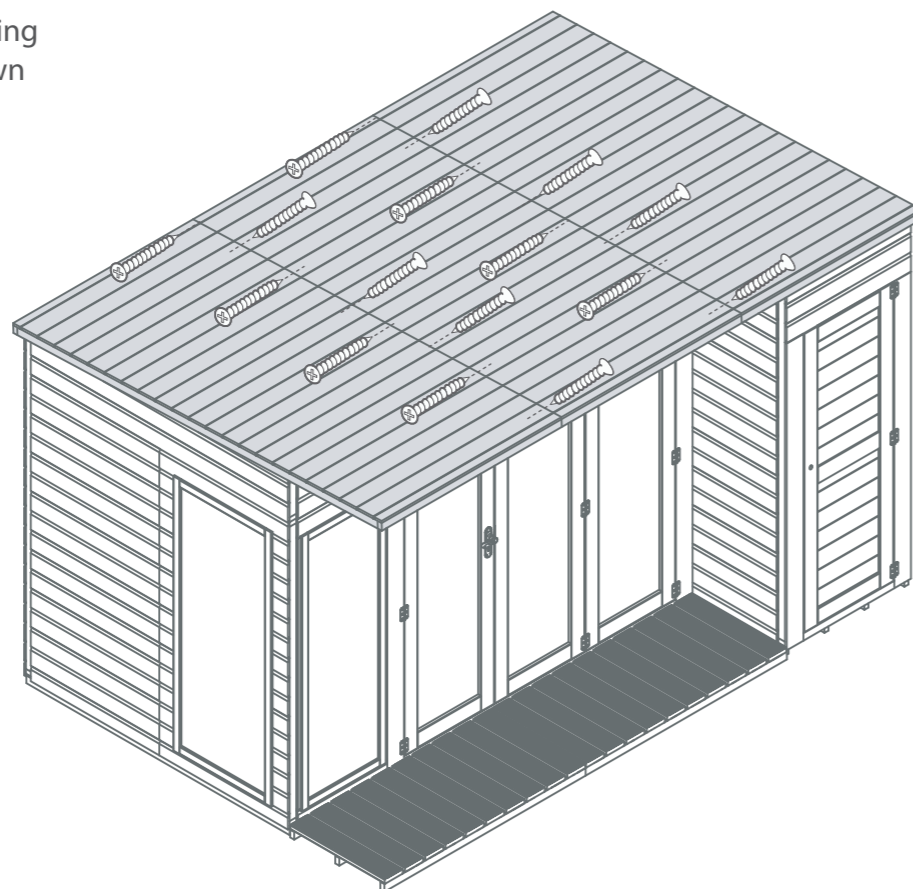

IMPORTANT: Pre-drill before fixing screws.

Step 25

Screw internally with 50mm screws securing the roof panels (No. 9) x 3 to all of the panels on the front and back of the building.

Do not secure the building to the Floor until the roof is fitted.

*External panels not shown

16x50mm Screws

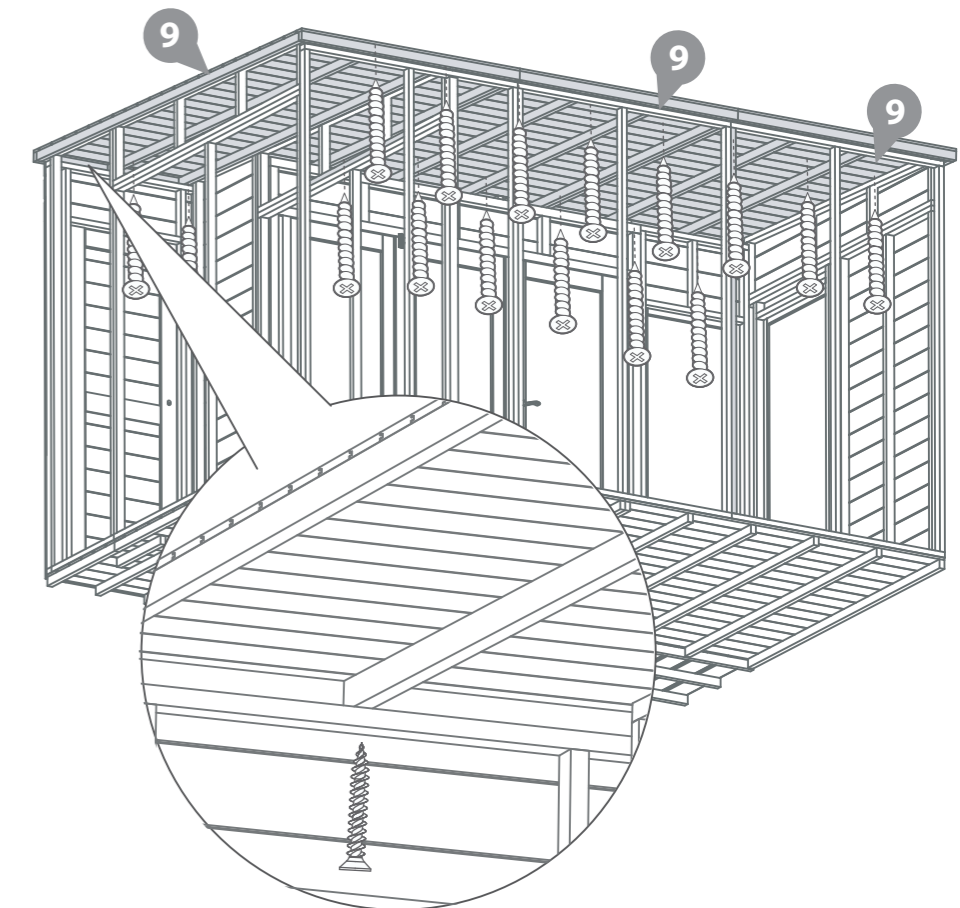

IMPORTANT: Pre-drill before fixing screws.

Step 26

Once the Roof is aligned and secure the Floor can be fixed into position.

Fix the building into place by screwing through the panel into the floor making sure to screw into the floor bearers.

***External panels not shown**

37x50mm Screws



Pre drill hole



50mm screw

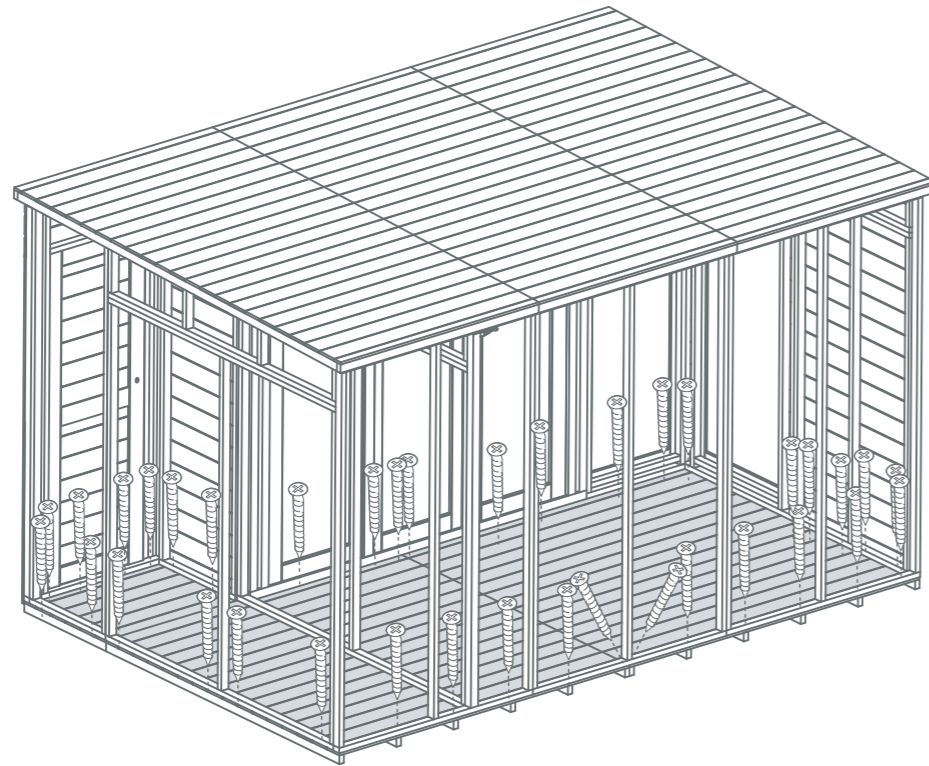

IMPORTANT: Pre-drill before fixing screws.

Step 27

Parts Needed - No. 35 QTY 1

Cut the Felt (No. 35) into 3 sheets at 3700mm lengths each and lay onto the roof.

***Ensure there is approximately 50mm of overhang around the building.**

Fix into place using 150 x felt tacks at 100mm intervals.

150x Felt tacks



Felt tacks

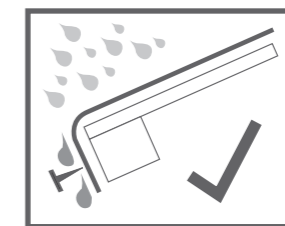
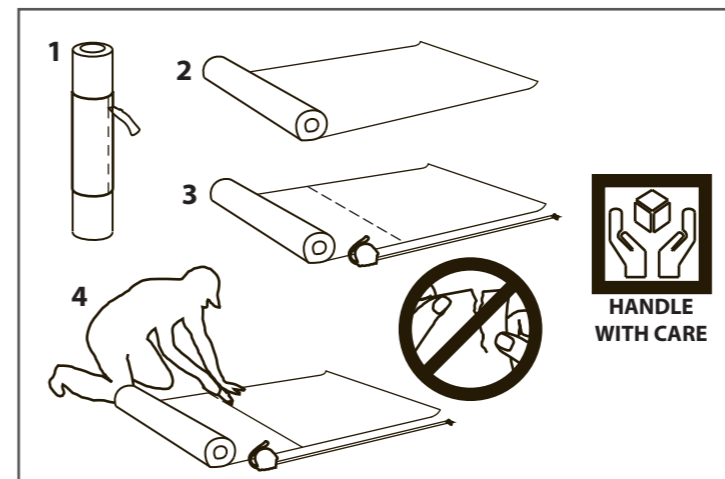
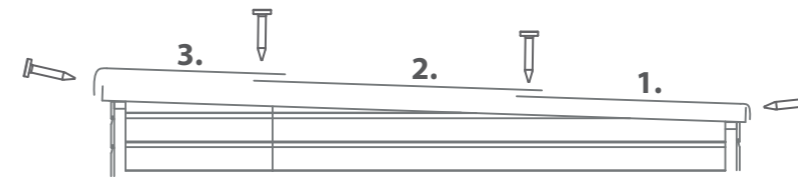
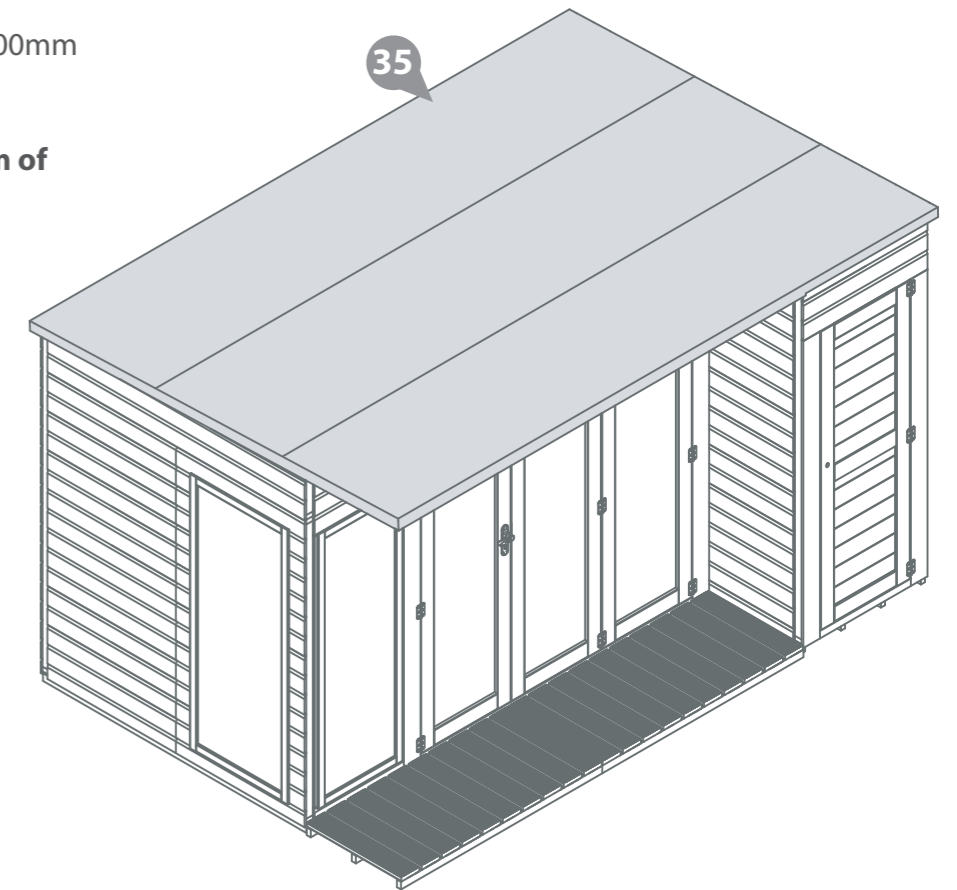

Step 28

Parts Needed - No. 30 QTY 4
- No. 31 QTY 2

Fix the Fascias (4x No. 30 and 2x No. 31) into position as shown.

No. 31 are for the front and No. 30 are for the side.

Fix in place using 3x30mm screws per Fascia.

18x30mm Screws

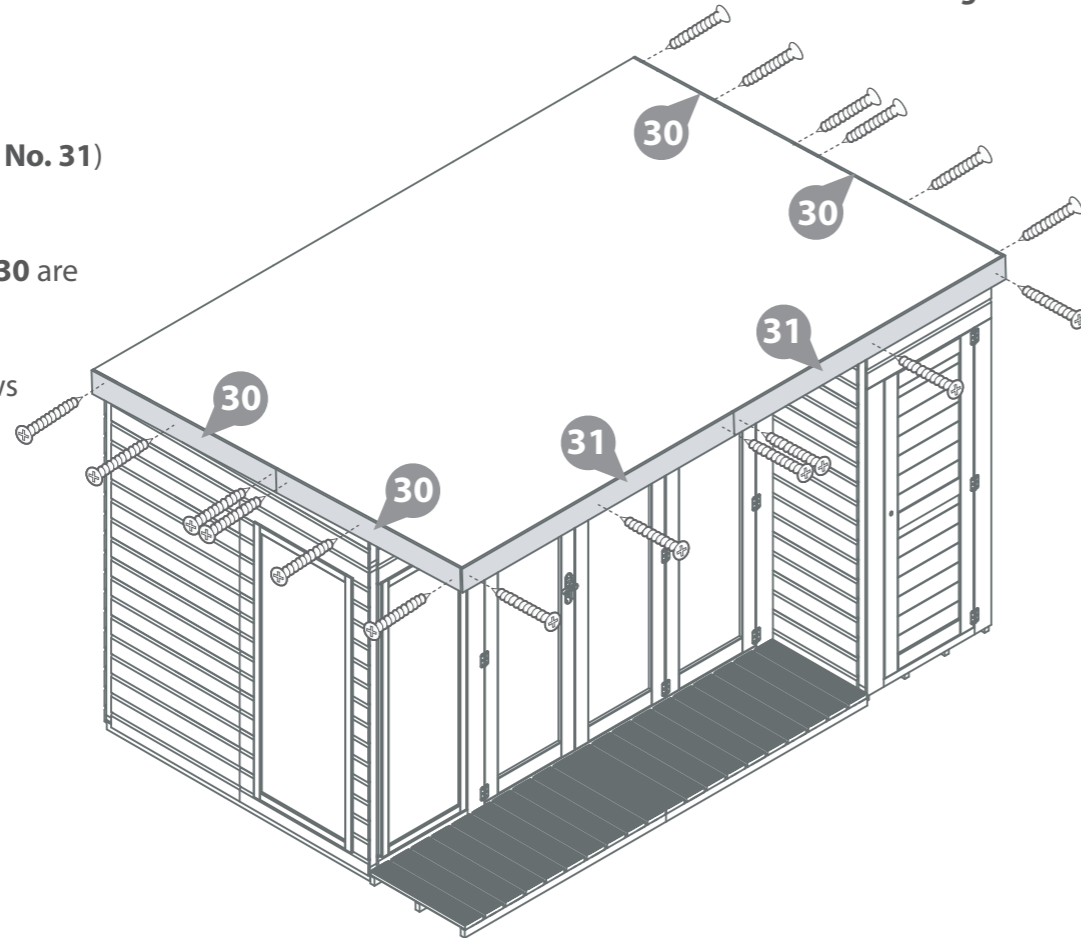

IMPORTANT: Pre-drill before fixing screws.

Step 30

Parts Needed - No. 38 QTY 2
- No. 39 QTY 1

To fix the lock to the Shed Door, first fix the Door Blocks (No. 38) either side of the centre framing of the Door with 4x40mm screws.

Once the Door Blocks are in place the Lock (No. 39) can be fixed in place as shown with 4x40mm screws, making sure to align the key hole of the lock to the key hole of the door.

8x40mm Screws

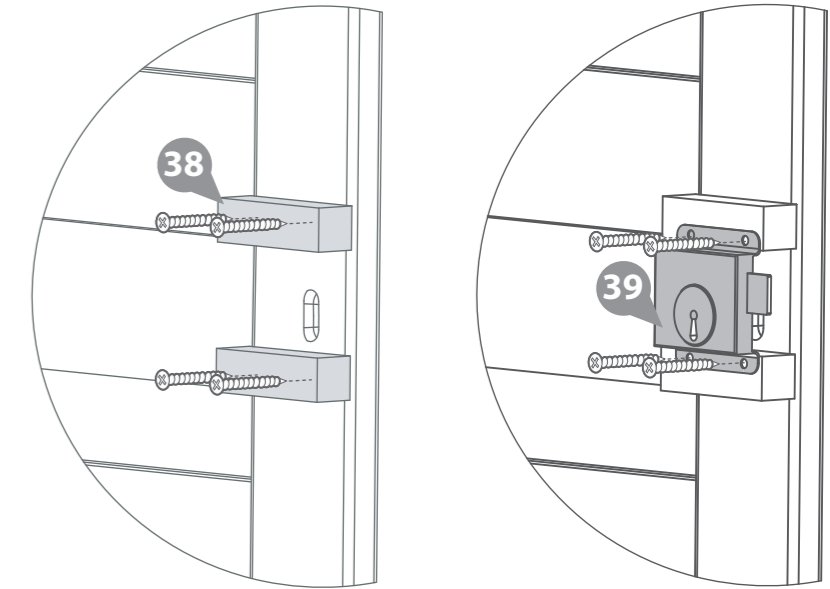

IMPORTANT: Pre-drill before fixing screws.

Step 29

Parts Needed - No. 24 QTY 2
- No. 25 QTY 2
- No. 26 QTY 1
- No. 27 QTY 1
- No. 28 QTY 1
- No. 29 QTY 2

Fix the Cover Trims (2x No. 24, 2x No. 25, No. 26, No.27, No.28 and 2x No. 29) into position as shown.

Fix each strip into position using 3x30mm screws per trim.

24x30mm Screws

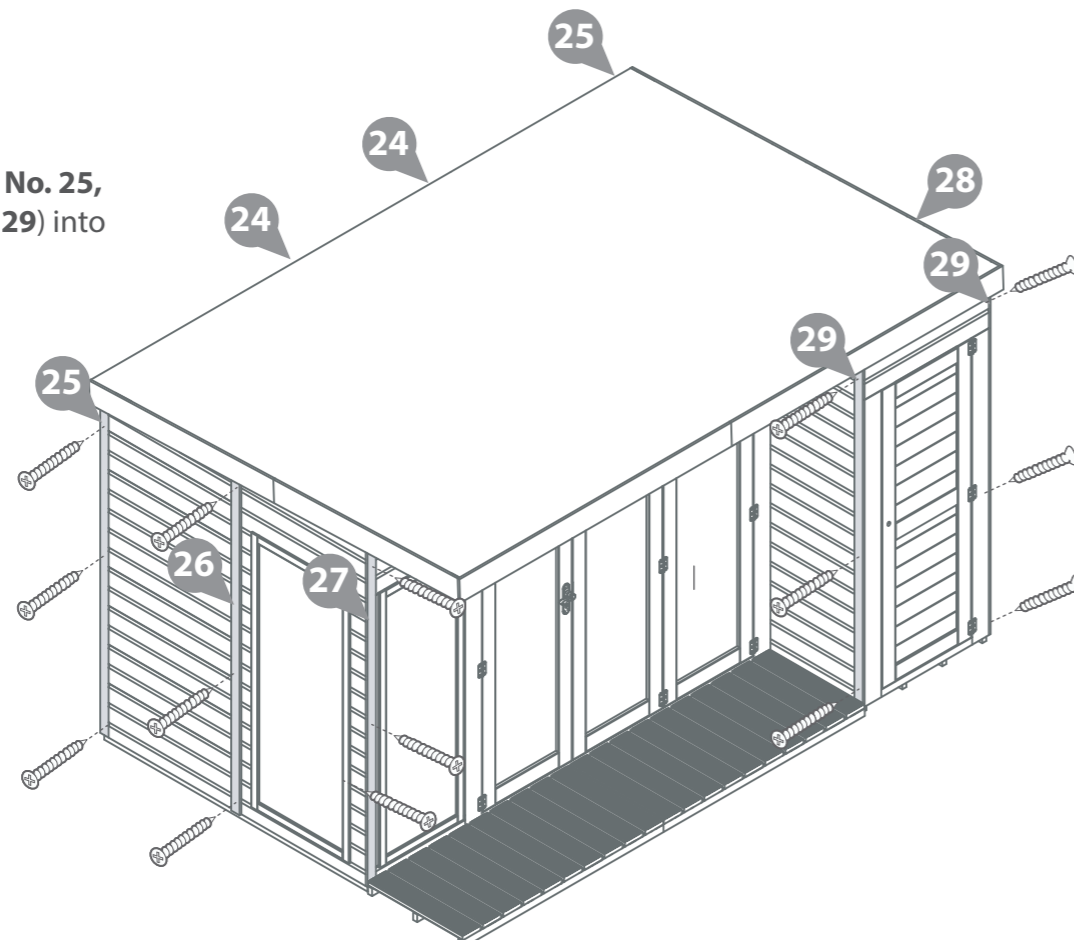

IMPORTANT: Pre-drill before fixing screws.

Step 31

Parts Needed - No. 34 QTY 1
- No. 36 QTY 1

Pre drill holes and then fix Chrome Handle (No. 36) using 45mm bolt as shown in diagram.

Fix Door Stop (No. 34) to bottom right of door panel at the back. Use 3x30mm screws.

2x45mm Bolt
3x30mm Screws

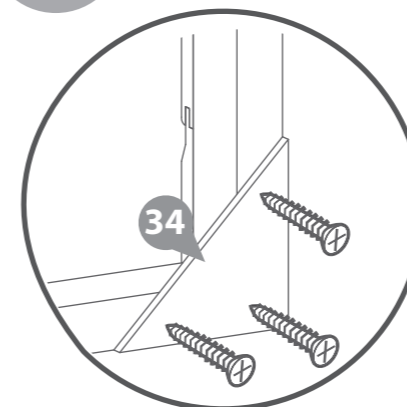

IMPORTANT: Pre-drill before fixing screws.

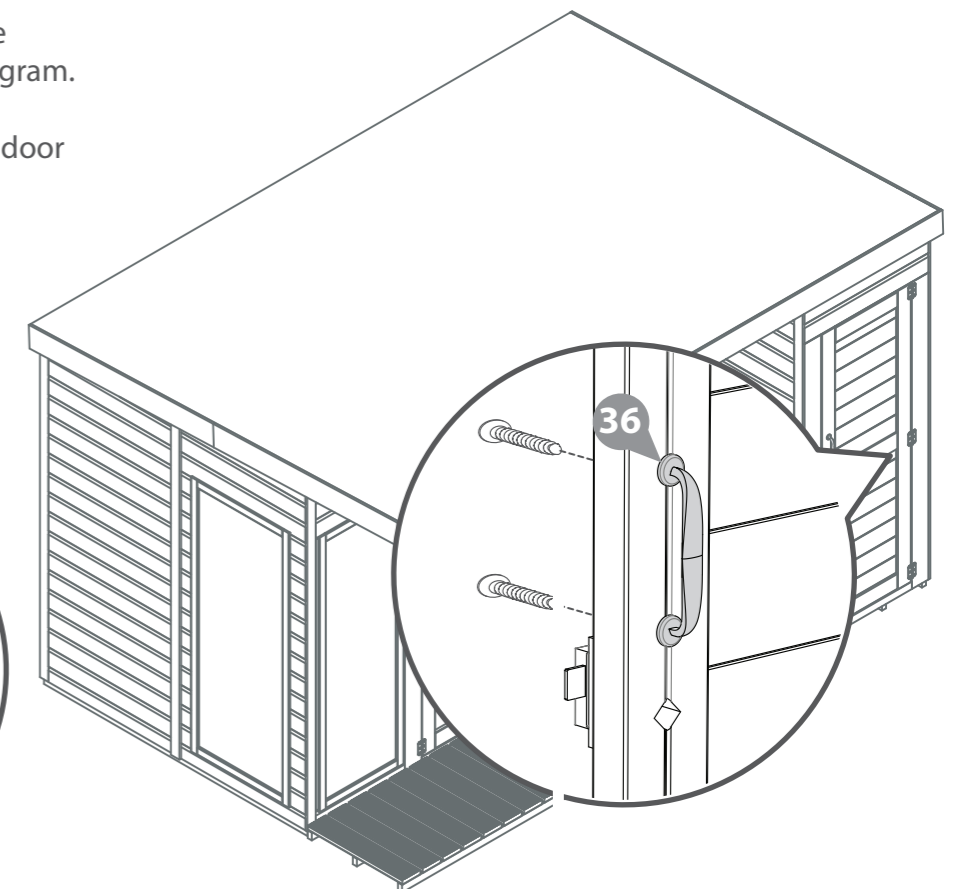

Step 32

Parts Needed - No. 44 QTY 4

IMPORTANT: Pre-drill before fixing screws.

Attach two Turn Buttons (No. 44) to the Storage Door Panel at the top and bottom of the door. Using 1x 30mm screw per Turn Button ensuring that the screws go through into the Storage Door Panel framing.

Attach two further Turn Buttons to the secondary Door at the top and bottom of the door using screws.

These Turn Buttons help to keep your doors straight during high and low levels of moisture content in the air.

4x30mm Screws

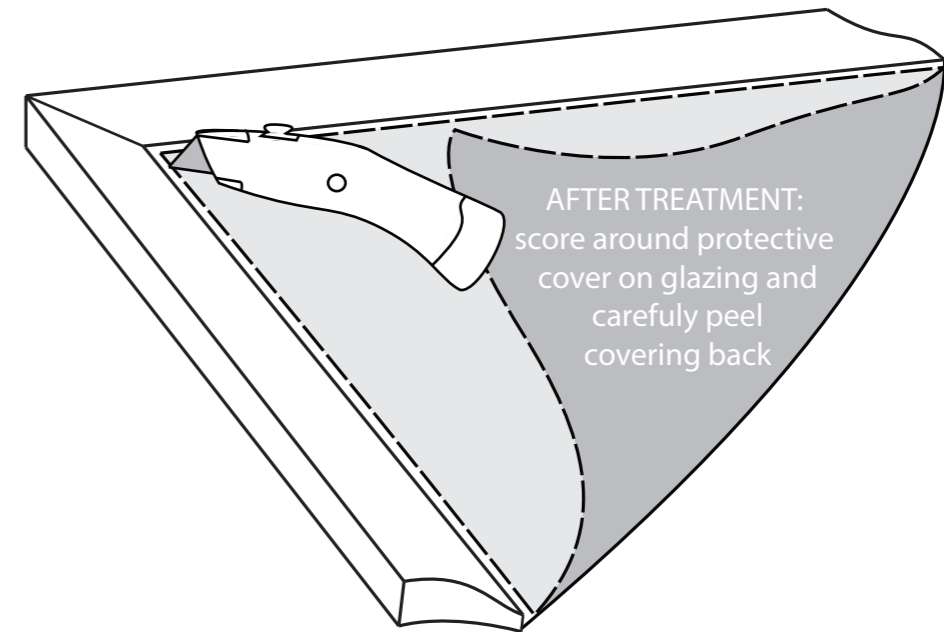
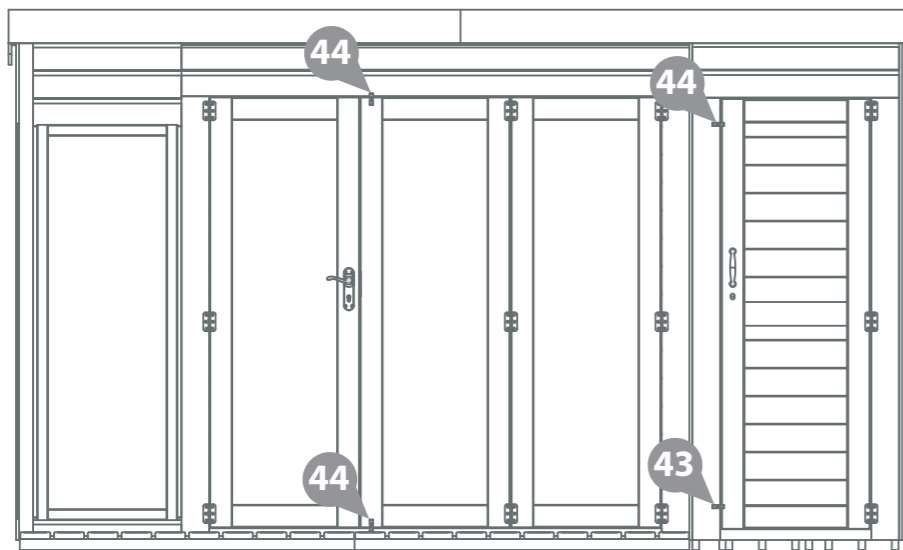
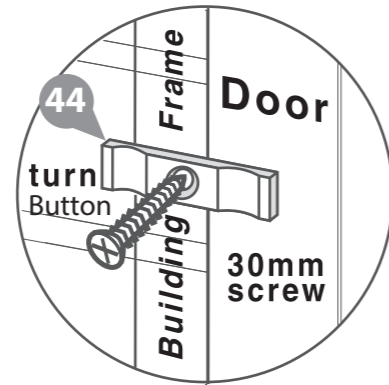

All our garden buildings have been designed and manufactured with care and attention to be the perfect addition to your outdoor space. To ensure you do get the best out of your new garden building and to increase the longevity we advise that you follow the product instructions and our manufacturer's recommendations as detailed below. Thank you for choosing a Mercia Garden product!

1 Choosing the most suitable location for your garden building...

A minimum of 60cm should be left around the perimeter of your garden building to allow access for maintenance, annual treatment and to allow air flow around the building.

Where possible you should avoid placing your garden building underneath large trees to prevent the tree causing damage to the building.

2 Preparing the base for your garden building...

All our buildings must be built on a firm, level base to ensure the longevity of the building and prevent the wood from distorting. We recommend either concrete, concrete slabs or a wooden base, such as our 'Portabase'.

The base should be slightly smaller than the external measurement of the building, i.e. the cladding should overlap the base, creating a run off for water and preventing water from pooling underneath the building.

We also recommend that the floor of the garden building is a minimum of 25mm above the surrounding ground level to avoid flooding.

3 After installation...

Once your garden building has been installed it will need to be treated as soon as possible and annually to prevent the timber from deteriorating and to waterproof it. This is required to maintain the anti-rot guarantee.

Dip Treated buildings - Require a preservative treatment to protect against rot and decay and a waterproof treatment to prevent water ingress

Pressure Treated buildings - Require a waterproof treatment to prevent water ingress

Log Cabins/Insulated Garden Rooms - Are supplied untreated and require a preservative and waterproofing treatment

We also recommend using a silicon sealant on the inside and outside of the windows as soon as possible after assembly and treatment to fully seal the windows.

Roofing felt/covering should be checked annually and replaced or fixed accordingly.

4 General maintenance and wood characteristics

As wood is a natural material it may be affected by the following:

Shrinkage and warping - The timber used in the construction of your garden building will have retained some of its natural moisture content. The moisture content of the timber will vary, depending upon prevailing environmental conditions, which will result in the components either naturally expanding or contracting. As the components dry out shrinkage may occur. A good waterproofing treatment from the start is the best protection to minimise the effect of moisture loss/intake.

In extended periods of very warm weather getting some moisture to the building will help the overall balance. You can do this by spraying it down lightly with a garden hose. In contrast after snow fall try to remove the snow as best as possible from the roof to prevent moisture intake and to remove the extra weight.

Top tip - using a garden brush will help you to reach the highest part of the building to remove snow and any debris left from bad weather.

Damp and mould - During the winter months, cold and damp conditions can result in an increased amount of moisture within your garden building, especially when used infrequently. Condensation can form on the timber and other items stored within your garden building. If left this moisture is likely to cause mould and mildew. To prevent the build-up of moisture, we recommend leaving the door or windows of your building open from time to time, to allow the fresh air to circulate. We also advise against storing wet or damp items in your garden building as this will also increase the level of moisture in the building. If mould or mildew does start to form within your building we recommend using an anti-mould cleaner to remove it and to prevent it spreading, which if left untreated could permanently damage your garden building.

Splits, cracks and knots - You may notice small splits and cracks in some components or holes may appear where knots shrink and fall out. This will not affect the structure of your Garden building however if you wish to fill them this can be easily done using any good quality wood filler.

Sap - is naturally occurring in wood and may appear in some boards of your garden building. If you wish to remove the sap, we advise waiting until it is dry and then using a sharp knife to carefully remove it. If the removal of the sap causes a hole in the timber, we recommend using a good quality wood filler to fill it.

For more handy hints and tips on how to care and maintain your garden building please refer to the MGP Customer Portal at www.mgplogistics.co.uk

Any further questions?

Contact our
Customer Service
Team on:
01636 821215

1 Manufacturer's Warranty

All Mercia Garden Products are supplied with a 1 year warranty on all parts against manufacturing defects.
This warranty does not cover movement, warping or splitting of timber products over time.

This warranty will be voided if any of the following occur:

1. The building has been customised or modified/adapted in any way.
2. The person claiming is not the original purchaser of the building.
3. Any damage has been caused by or as a result of misuse.
4. The building has not been maintained and cared for in accordance to our advisories and manufacturer's recommendations.
5. The building has not been treated annually or as per the manufacturer's recommendations, please ensure receipts are kept to validate this claim.
6. The building has not been erected, fitted or installed as per the supplier instructions.
7. The building has not been erected on a suitable sized firm flat, solid level concrete/slab base or placed on pressure treated bearers.
8. The building is or has been placed with 2 feet (60cm) of any obstructions (walls, trees, plants, fences etc.) which can allow moisture to penetrate the timber.
9. The roofing felt has been incorrectly fitted or damaged allowing water ingress, or not properly maintained.
10. Any windows and joints have not been sealed, inside and out, with silicone or other watertight sealant.
11. Any timber has been cut, pierced or drilled without subsequent application of approved cut-end treatment.



REGISTER FOR YOUR
ANTI-ROT
GUARANTEE TODAY

PLEASE SCAN HERE:



2 Anti-rot Guarantee

Mercia Garden Products offer a 10 year anti-rot guarantee on all dip treated (a preparatory treatment) and 15 years on all pressure treated products. This guarantee covers solid timber against rot, decay, blue stain and insect attack.

To validate the guarantee the building must be treated with a recognised wood preserver/water proof top coat (as detailed within manufacturer's recommendations) as soon as possible after assembly and annually thereafter.

This guarantee does not cover movement, warping or splitting of timber products over time.

This guarantee will be voided if any of the following occur:

1. The building has been customised or modified/adapted in any way.
2. The person claiming is not the original purchaser of the building.
3. Any damage is caused by or as a result of misuse.
4. The building has not been maintained and cared for in accordance to our advisories and manufacturer's recommendations.
5. The building has not been treated annually or as per the manufacturer's recommendations, please ensure receipts are kept to validate this claim.
6. The building has not been erected, fitted or installed as per the supplier instructions.
7. The building has not been erected on a suitable sized firm flat, solid level concrete/slab base or placed on pressure treated bearers.
8. The building is or has been placed with 2 feet (60cm) of any obstructions (walls, trees, plants, fences etc.) which can allow moisture to penetrate the timber.
9. The roofing felt has been incorrectly fitted or damaged allowing water ingress, or not properly maintained.
10. Any windows and joints have not been sealed, inside and out, with silicone or other watertight sealant.
11. Any timber has been cut, pierced or drilled without subsequent application of approved cut-end treatment.