

0619LOG003-V5 (3x3.3m)
0619LOG003-V5: 3x3.3m 19mm apex cabin

BEFORE YOU START PLEASE READ INSTRUCTIONS CAREFULLY

- Check the pack and make sure you have all the parts listed.
- When you are ready to start, make sure you have the right tools at hand (not supplied) including a Phillips screwdriver, Stanley knife, wood saw, step ladder and drill with 2mm bit.
- Ensure there is plenty of space and a clean dry area for assembly.

TIMBER

As with all natural materials, timber can be affected during various weather conditions. For the duration of heavy or extended periods of rain, swelling of the wood panels may occur. Warping of the wood may also occur during excessive dry spells due to an interior moisture loss. Unfortunately, these processes cannot be avoided but can be helped. It is suggested that the outdoor building is sprayed with water during extended periods of warm sunshine and sheltered as much as possible during rain or snow.

BUILDING A BASE

When thinking about where the building and base are going to be constructed: Ensure that there will be access (60cm) to all sides for maintenance work and annual treatment.

Ensure the base is level and is built on firm ground, to prevent distortion. Refer to diagrams for the base dimensions. The base should be slightly smaller than the external measurement of the building, i.e. The cladding should overlap the base, creating a run off for water. It is also recommended that the floor be at least 25mm above the surrounding ground level to avoid flooding.

TYPES OF BASE

- Concrete 75mm laid on top of 75mm hard-core.
- Slabs laid on 50mm of sharp sand.

Whilst all products manufactured are made to the highest standards of Safety and in the case of childrens products independently tested to EN71 level, we cannot accept responsibility for your safety whilst erecting or using this product.

Refer to the instructions pages for your specific product code



All buildings should be erected by two adults



Winter = High Moisture = Expansion
Summer = Low Moisture = Contraction



2mm Drill bit

For ease of assembly, you **MUST** pilot drill all screw holes and ensure all screw heads are countersunk.



CAUTION

Every effort has been made during the manufacturing process to eliminate the prospect of splinters on rough surfaces of the timber. You are strongly advised to wear gloves when working with or handling rough sawn timber.



For ease of assembly use a rubber mallet to fit the log boards. Do **NOT** use a heavy hammer.



Ensure to measure and check before cutting boards.



It is advisable to use a hand saw when cutting roof and floor boards



To ensure log boards are even, use a spirit level to check each layer has been installed correctly.

Screws & Nails

Measure overall length

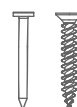

Bolts

Measure under the head



To identify the fixings required for each step use a measuring tape.

For assistance please contact customer care on: 01636 821215

Mercia Garden Products Limited,
Sutton On Trent,
Newark,
Nottinghamshire,
NG23 6QN

www.merciagardenproducts.co.uk



Overall Dimensions:
 Width = 3445mm
 Depth = 3032mm
 Height = 2645mm

Base Dimensions:
 Width = 3099mm
 Depth = 2799mm

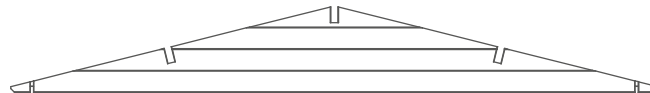
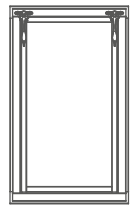
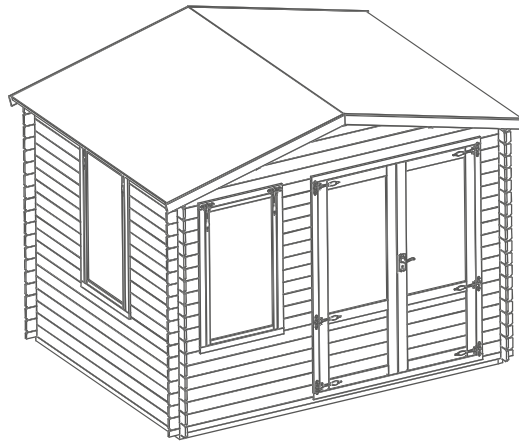

Short Window Pack* Double Door Pack*
QTY 2

Gable 3296mm
 AI-0619LOG002G
QTY 2

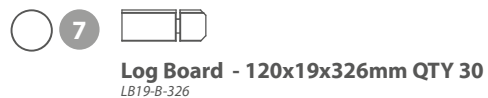
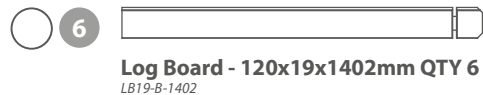
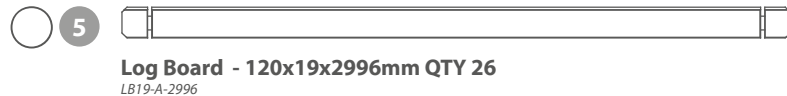

***All components for the Windows and Doors are shown in the Windows and Doors instruction packs.**

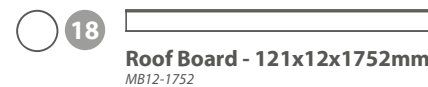
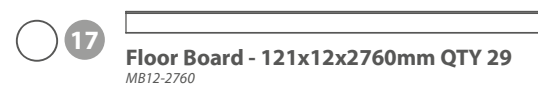
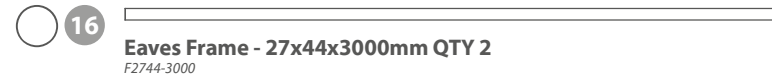
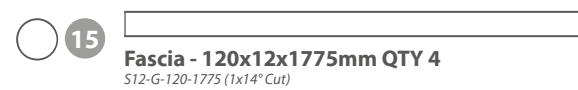
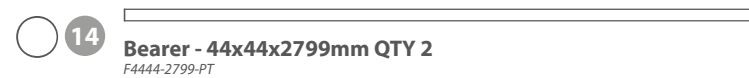
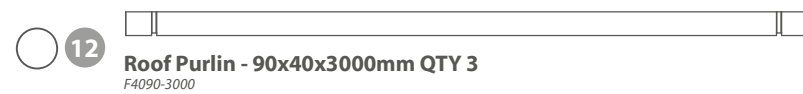

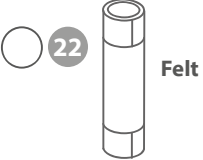

Felt







23
Log Board - 110x19x2996mm QTY 1
LB19RG110-A-2996



24
Roof Spacers QTY 5
PI-07-0208 (20x100x2mm)

Nail Bag
There may be extra screws present in the nail bag

-  **60mm Bolt Set x16**
-  **30mm Screw x102**
-  **70mm Screw x72**
-  **40mm Screw x396**
-  **Felt Tacks x200**

Pre-assembly

**Please note:*

Each board interlocks at either end in a staggered pattern.

Before securing ensure that the boards are fitted properly in their respective tongues and grooves.

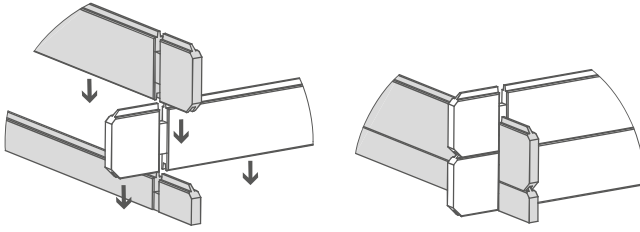

Step 1
Parts Needed - No. 13 QTY 10
No. 14 QTY 2

a Lay the bearers (**No's. 13 & 14**) onto a firm and level surface (**free from areas where standing water can collect**) as shown in the illustration.

Fix the framing together at each corner screwing 2 screws per corner using 8x70mm screws, ensuring the frame is flush.

8x70mm Screws

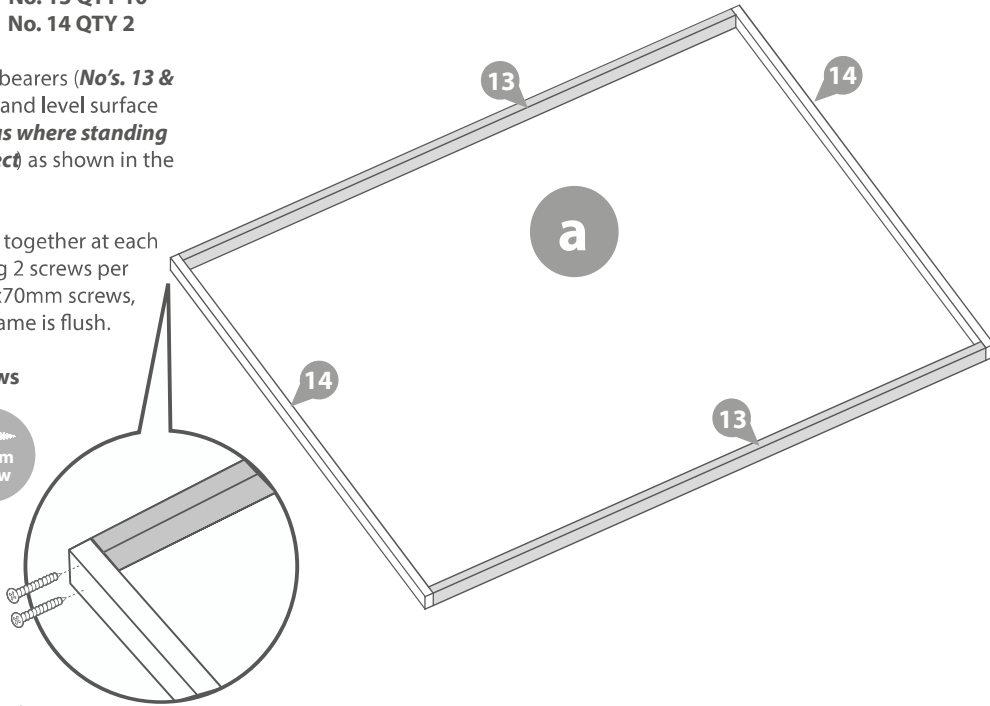

IMPORTANT Pre-drill before fixing screws.

b Following the same method arrange the remaining framing (**No. 14**) inside the assembled frame.

***Ensure there is an equal amount of space between each frame.**

Secure each of the frames in place using 2x70mm screws for each side of the bearer, ensuring the framing remains level.

44x70mm Screws

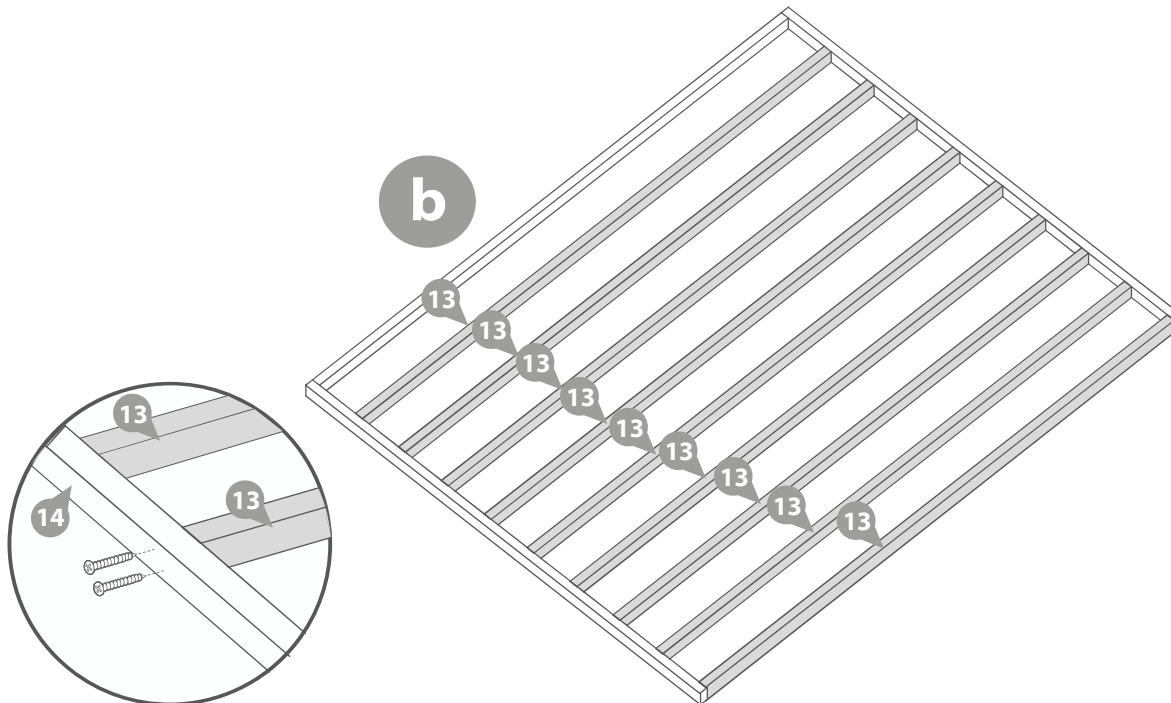

Step 2
Parts Needed - No. 4 QTY 2
No. 5 QTY 2

Place the starter boards (**No's. 4 & 5**) on to assembled base frame along the longest sides.

***Ensure the notches at either end of each board are flush and level with the ends of the frame.**

Fix each of the starter boards to the frame by screwing through the notch into the frame as shown in the illustration.

4x70mm Screws

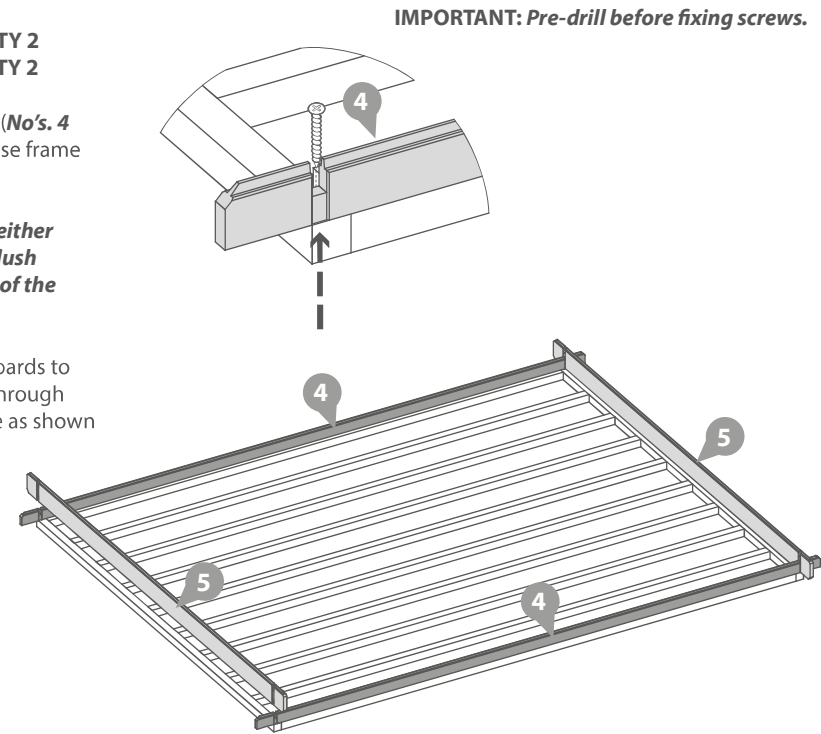

IMPORTANT: Pre-drill before fixing screws.

Example picture
2 screws per bearer per end

Step 3

Parts Needed - No. 5 QTY 12
No. 6 QTY 6
No. 7 QTY 6
No. 9 QTY 6

Following the same method outlined in *Pre-Assembly*, lay the first 6 boards (**No's. 5, 6, 7 & 9**) onto the starter boards to create your first level.

***Ensure that the boards are level and flush with each other as you lay each one.**

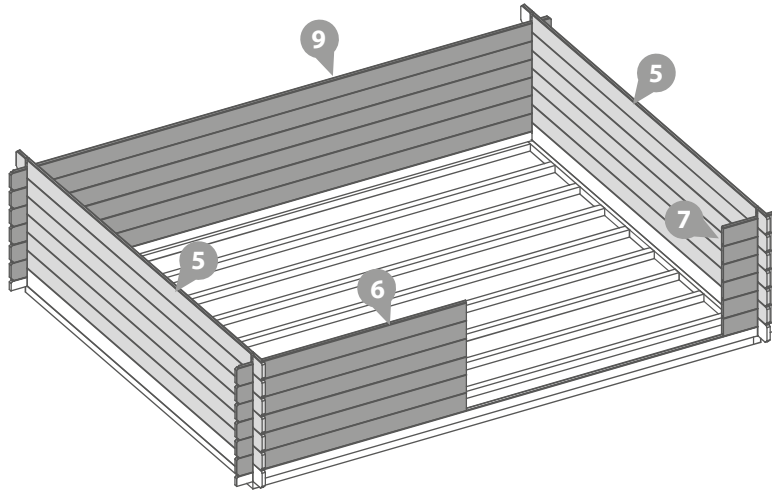

Step 5

Parts Needed - No. 5 QTY 6
No. 7 QTY 13
No. 8 QTY 7
No. 9 QTY 7
No. 10 QTY 12

Following the same method outlined in *Pre-Assembly*, lay the next 6 boards (**No's. 5, 7, 8, 9 & 10**) onto the assembly to create your second level.

***Ensure that the boards are level and flush with each other as you lay each one.**

***Doors can be hung once the boarding has enclosed the door frame by 13-14 boards, refer to Door installation instructions, if not, you can install the doors at Step 7**

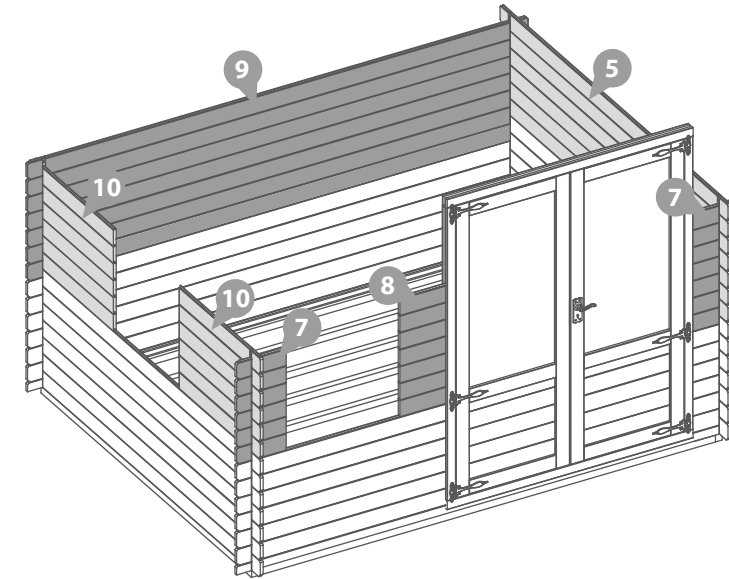

Step 4

Once you have laid 6 log boards (*off of the starter*) up the door section, slide the assembled door frame (**No. 2**) over the boards resting the frame on top of the starter board.

Please refer to your window and door instructions for assembly.

***Please note:** This image is for illustrative purposes and may differ from your choice in product (**regarding door position**). Nevertheless the process of fitting the door frame is the same.

****Please Note:** The short boards at the front of the building (either side of the door and window opening's) can be placed either side depending on your needs.

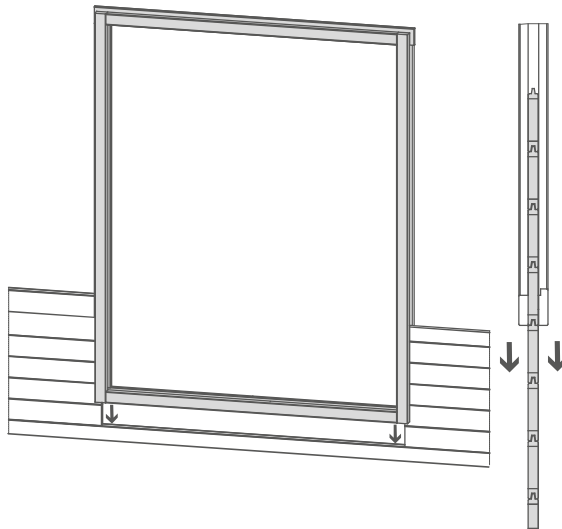

Step 6 (See Window-Assembly)

Parts needed - No. 1 QTY 2

Refer to window assembly instructions to assemble windows.

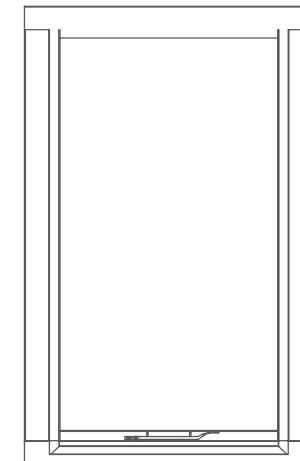

Step 7

Once you have laid the second level of boards onto the assembly slide the window(s) (**No. 1**) between the smaller boards and rest on to the longer board.

Please refer to your window and door instructions for assembly.

***Ensure the boards are level with each end.**

***Please note:** This image is for illustrative purposes and may differ from your choice in product (**regarding window position**). Nevertheless the process of fitting the window is the same.

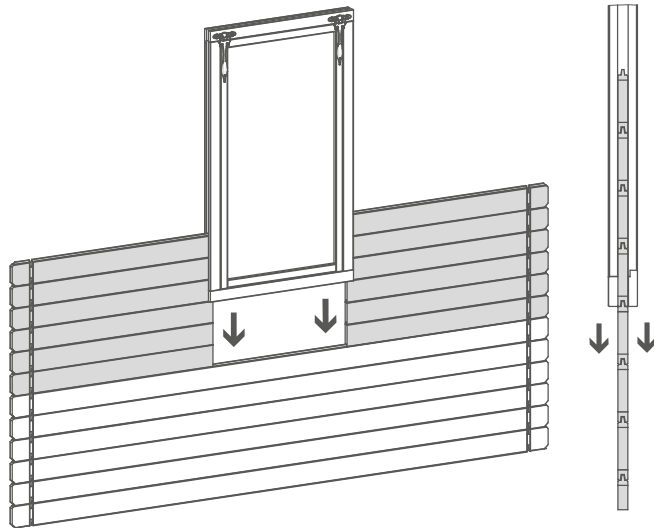

Tip: Ensure the lip on the window frame is located on the inside of the building

Step 9

Parts Needed - No. 9 QTY 1
No. 24 QTY 1
No. 20 QTY 1
No. 21 QTY 1

Following the same method outlined in *Pre-Assembly*, lay the last two boards (**No's. 9 & 20**) onto the front and rear of the assembly.

Once in position place log boards (**No's. 24 & 21**) onto the window and plain side.

***Ensure that the boards are level and flush with each other as you lay each one.**

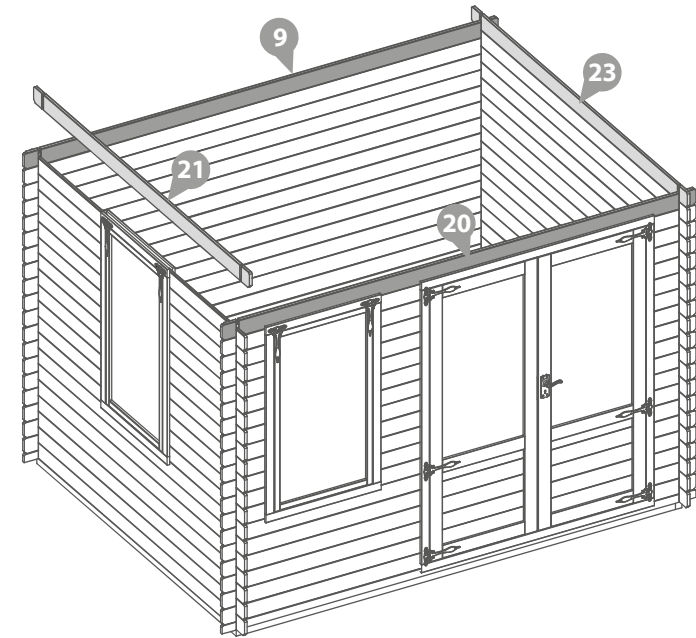

Step 8

Parts Needed - No. 5 QTY 6
No. 7 QTY 11
No. 8 QTY 5
No. 9 QTY 5
No. 10 QTY 12

Following the same method outlined in *Pre-Assembly*, lay the remaining boards (**No's. 5, 7, 8, 9 & 10**) onto the assembly to bring the board level to the top of the window and door frames.

***Ensure that the boards are level and flush with each other as you lay each one.**

***Doors can be hung once the boarding has enclosed the door frame.**

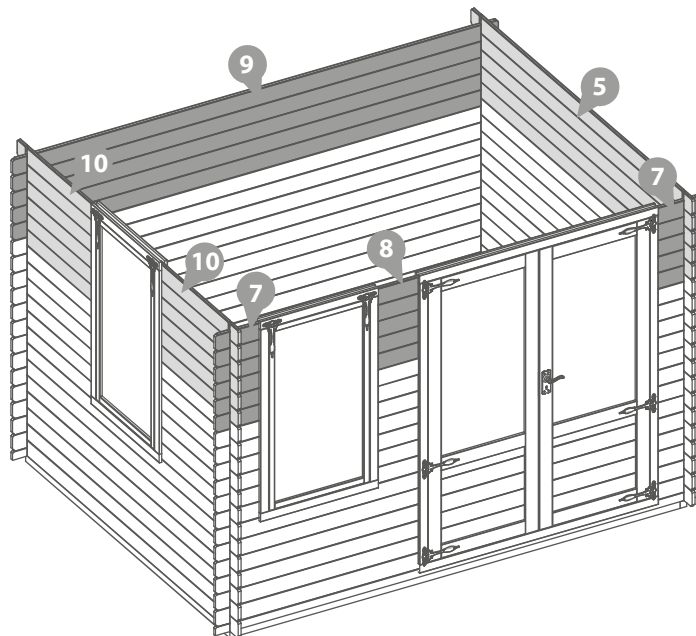

Step 10

Parts Needed - No. 3 QTY 2

Place the gable (**No. 3**) onto the assembly. Fix into position by screwing through the notches as shown in the illustration.

***Ensure that the boards are level and flush with each other as you lay each one.**

4x70mm Screws

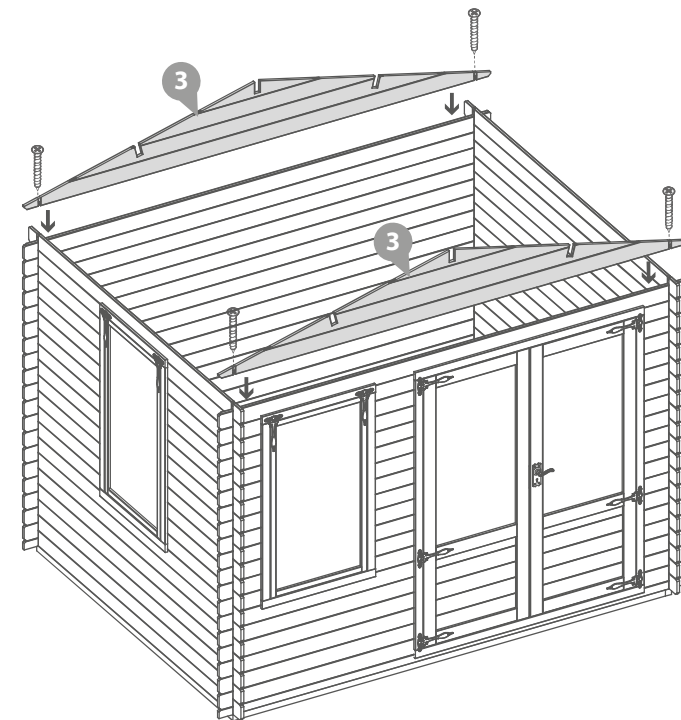
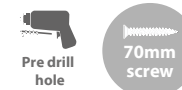

Step 11

Parts needed - No. 12 QTY 3

a Align the Roof Purlin(s) (No. 12) into the cut out slots on each gable top ensuring each Roof Purlin interlocks the boards.

b Secure the Roof Purlin at each end by screwing through the bars into the boards (**ensure to pre-drill to avoid the boards splitting**) using 4x70mm screws per Roof Purlin.

**Please note: The gable shown is for illustrative purposes and may differ in width from your choice in product. Nevertheless, despite any differences the process of fixing the Roof Purlins is the same.*

12x70mm Screws

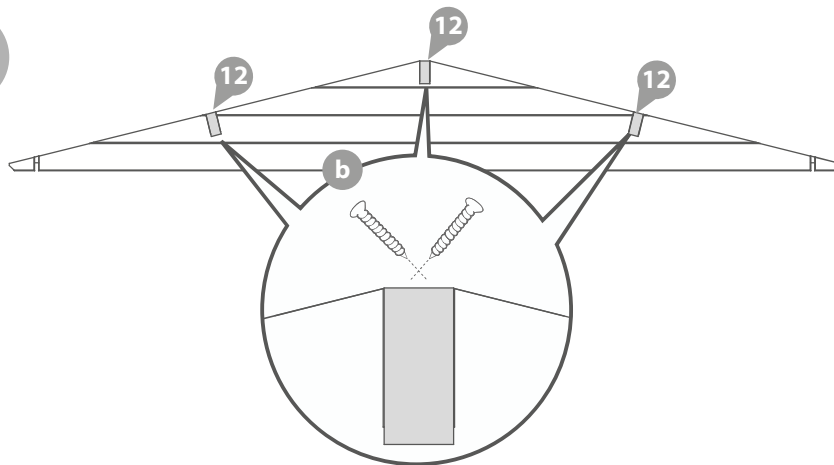

IMPORTANT: Pre-drill before fixing screws.

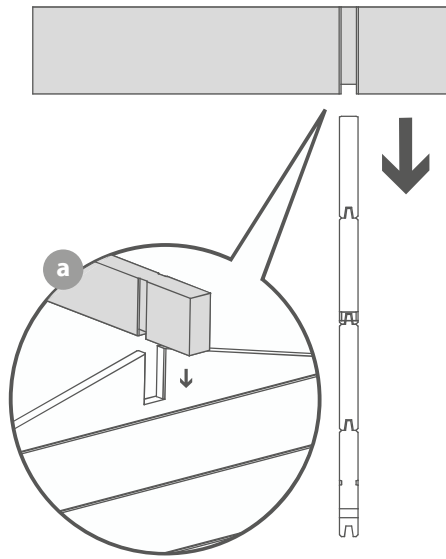

Step 12

Parts needed - No. 18 QTY 56

a Place the first two roof board's (No. 18) onto the assembly on each side, making sure the boards are flush to the end of the roof purlin. Once in position fix to each purlin using 3x40mm screws.

Use the spacer (No. 24) to create an expansion gap between each roof board if installing during low levels of moisture (summer). This creates an expansion gap for the boards to move into during high levels of moisture (winter).

Once in position fix to each purlin using 3x40mm screws.

You have been issued with 56 roof boards, but in reality you may only need to use 54.

***Ensure the roof boards meet at the top of the apex and leave an overhang at the bottom.**

Continue adding the roof boards along the roof, fixing each one into position using 3x40mm screws, making sure that each board is interlocked, flush at the bottom & meet at the top of the apex.

b The last board on each side will overhang: Using a straight edge and a pencil mark out a line as a guide.

Cut along the pencil mark and remove the excess. Place the cut down board's back onto the roof and secure into place using 3x40mm screws per board.

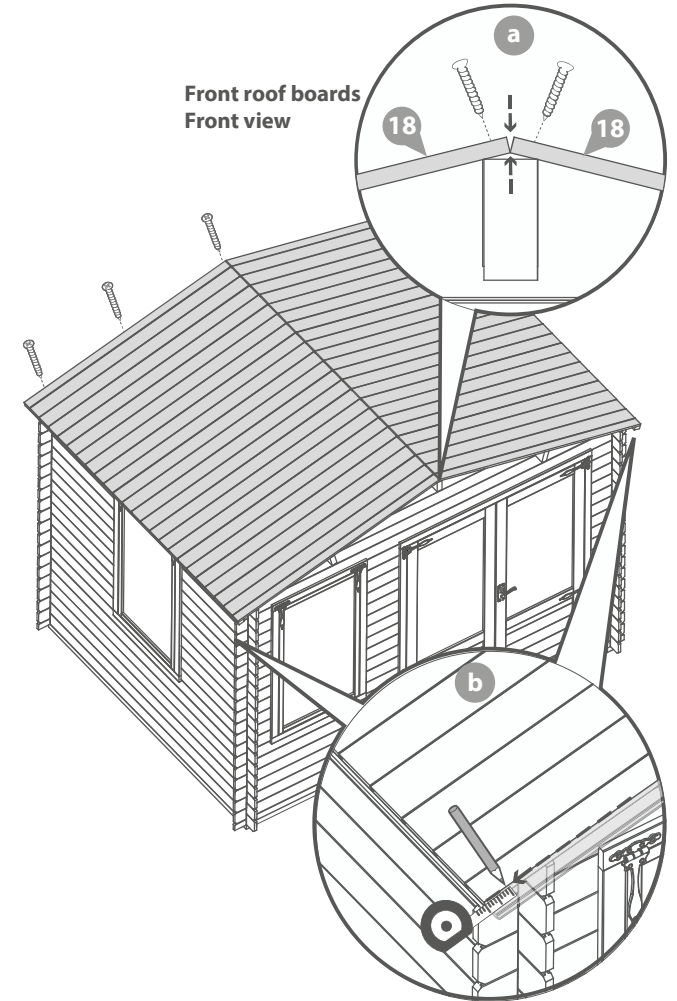
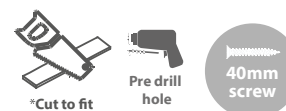

**Please Note: This image is for illustrative purposes and may differ from your choice in product. Nevertheless the process of cutting and fitting the last roof board(s) is the same.*

168x40mm Screws

Step 13
Parts Needed - No. 16 QTY 2

Ensuring the roof boards are flush at the overhanging side and meet at the apex, fix the eaves frames (**No. 16**) to the underside of the roof boards using 9x30mm screws as shown in the illustration

***Please Note:** This image is for illustrative purposes and may differ from your choice in product. Nevertheless the process of fixing the eaves frames is the same.

18x30mm Screws

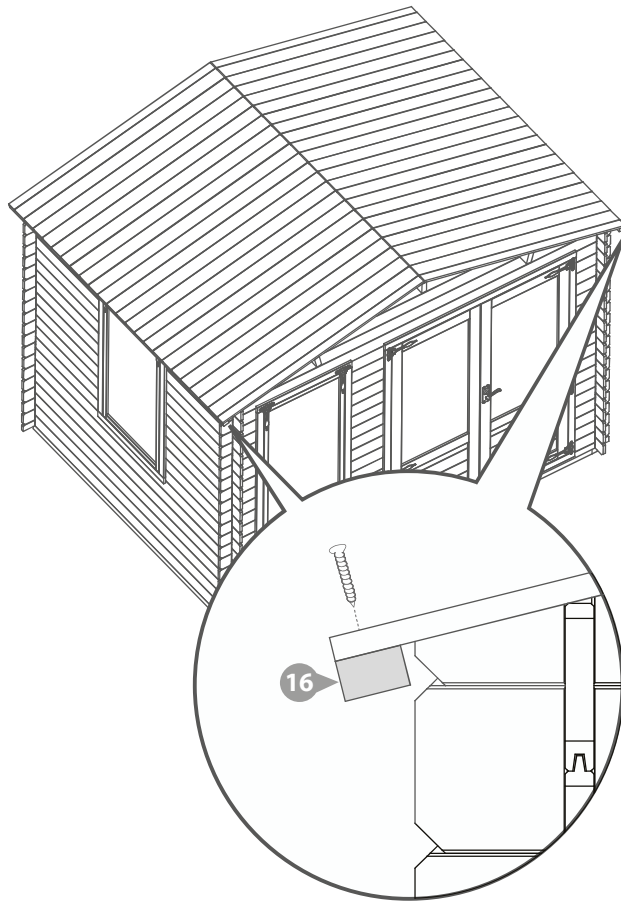
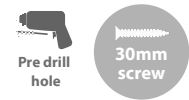

Step 14
Parts Needed - No. 17 QTY 29

Place the first floor board (**No. 17**) inside the building flush to the log board on one side. Continue adding the floor boards (*internally*) making sure to interlock each individual board.

You have been issued with 29 floor boards, but in reality you may only need to use 28.

***Do NOT secure the boards until the last board has been measured and cut.**

Following the same method outlined previously measure the gap between the bottom of the tongue (**on the last board placed**) and the log board.

Using a straight edge mark out the measurement onto the last floor board (**No. 17**) and cut along the length removing the excess.

****Please note:** Mark the final board 2mm under the measurement; This will allow the timber to expand and contract correctly.

Once all the floor boards are in position secure each board into position using 8x40mm screws.

*****Please Note:** Ensure to screw through each of the floor boards into the floor bearers.

216x40mm Screws

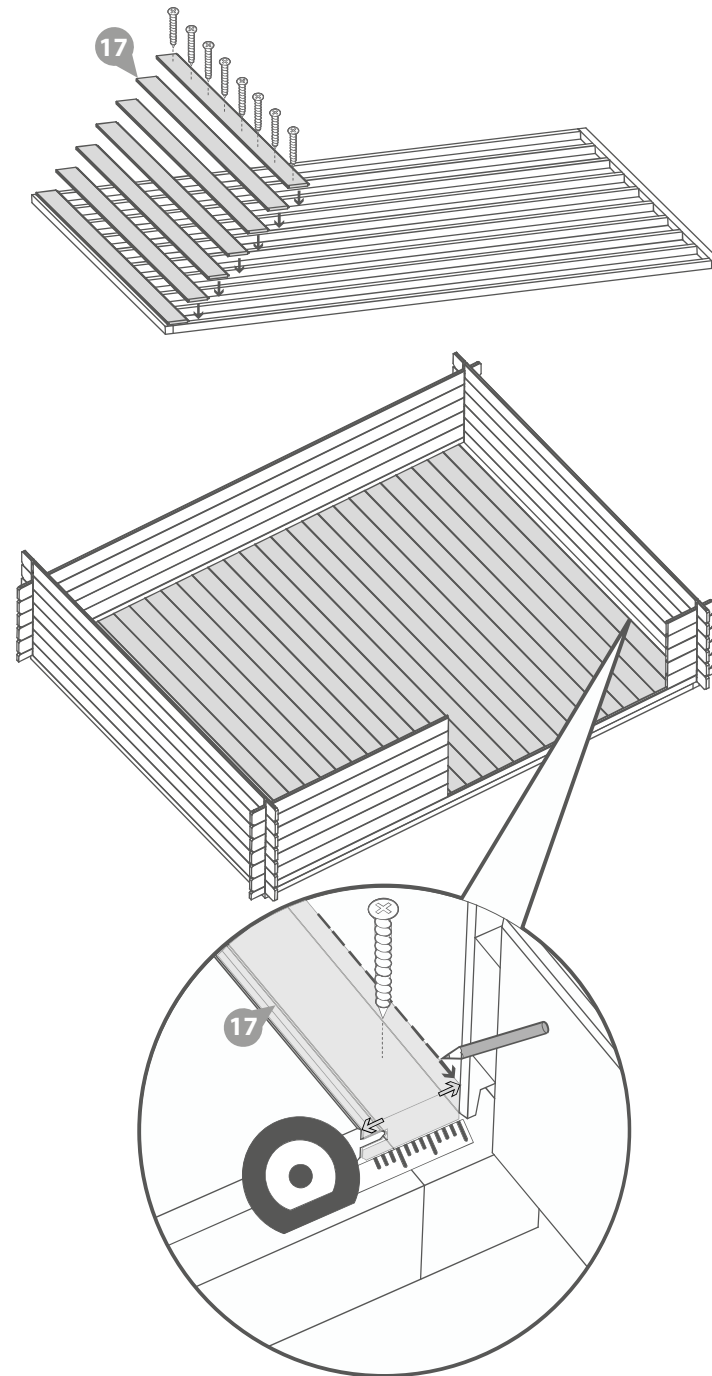
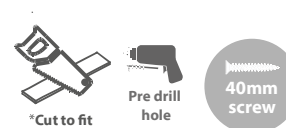

Step 15
Parts needed - No. 11 QTY 7

Inside the building place the closure trim (No. 11) against the boarding and align with the roof as shown in the illustration.

Once in position fix each trim into place by pre drilling a pilot hole and using 6x30mm screws per trim, equally spacing them along the face of the board.

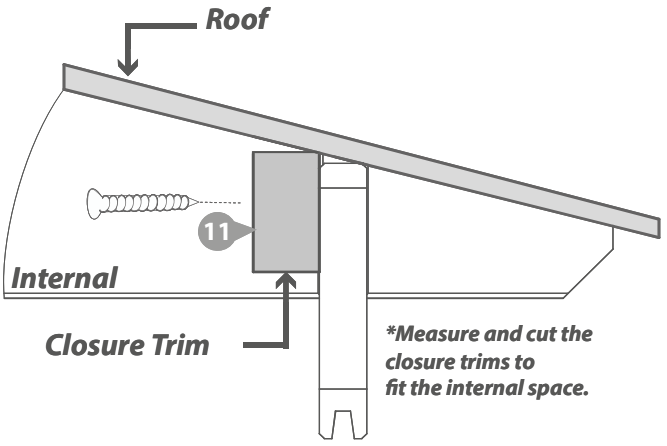
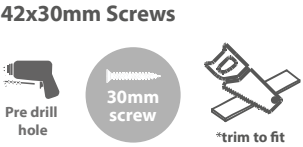

Step 16
Parts needed - No. 11 QTY 7

Once the floor has been laid arrange the closure trim (No. 11) around the outside edge of floor (*internally*), measure and cut down accordingly to best match the internal space.

Secure each trim section into place using 6x30mm spaced equally along the board as shown in the illustration.

***Do NOT fix the closure trim to the floor boards.**

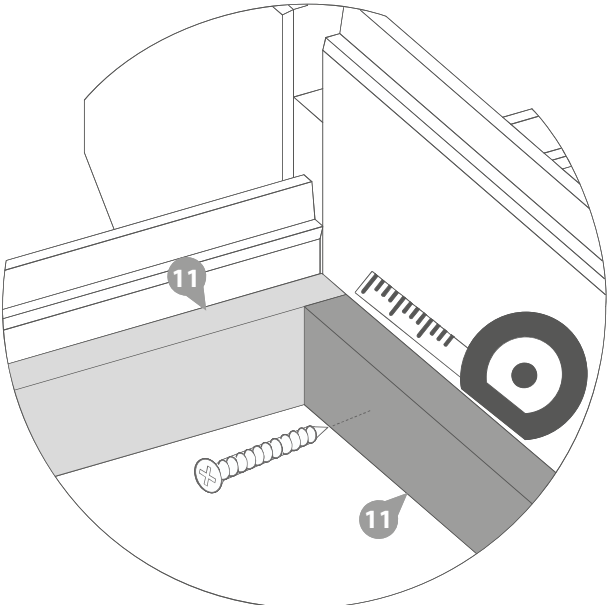

Step 17
Parts needed - No. 22

Cut the felt into five strips and lay onto the roof in the order shown in the illustration below.

***Ensure there is approximately 50mm of overhanging felt each side.**

Once the felt is laid out fix to the roof using felt tacks at 100mm intervals.

***Felt size: 3120mm**

170x Felt Tacks

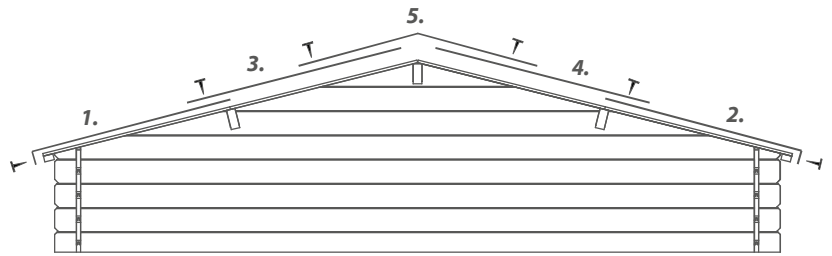
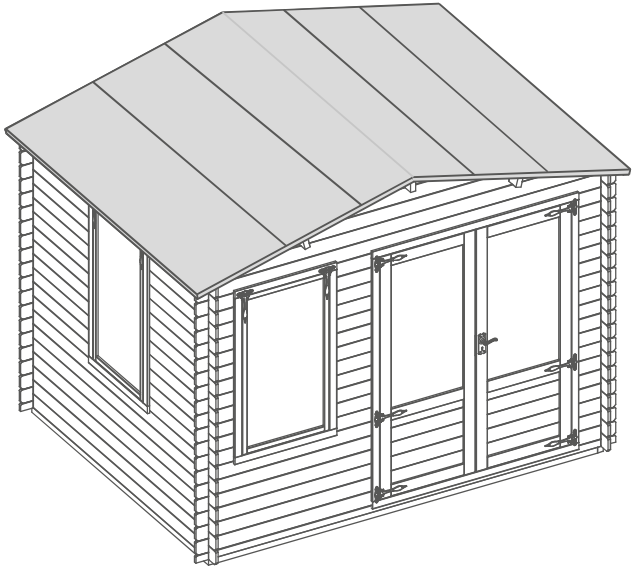

1. 2. 3. 4.

HANDLE WITH CARE

Step 18

Parts Needed - No. 15 QTY 4

Align the fascia's (**No. 15**) with the roof and fix into place using 3x40mm screws per fascia, making sure to screw through the fascia into the roof purlins and eaves frame.

***Ensure the angled cuts meet at the top of the apex.**

12x40mm Screws



40mm screw

IMPORTANT: Pre-drill before fixing screws.

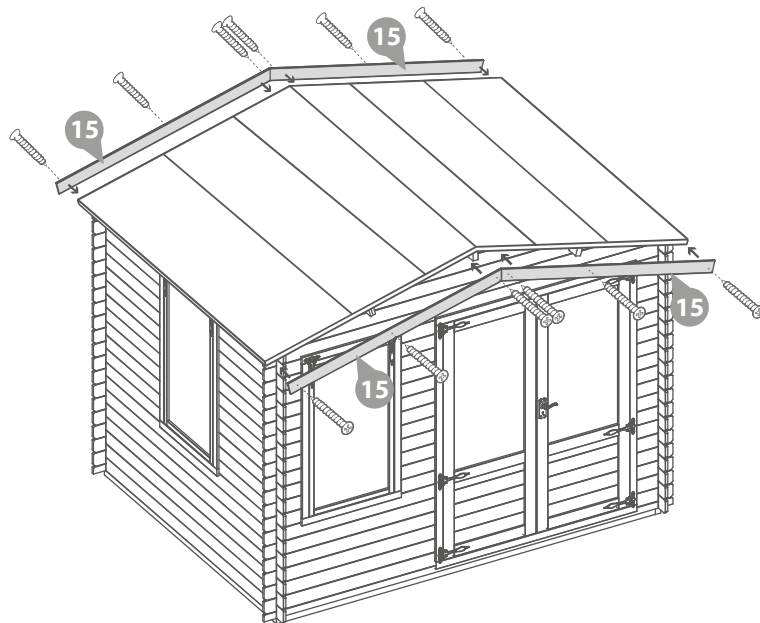

Step 19

Parts needed - No. 19 QTY 8

Arrange the storm braces (**No. 19**) around the building (**internally**). Place 2x storm braces per side fixing into place using 2x 60mm bolts per brace making sure the washer & nut are tightened from the outside of the building.

The storm braces will need to be altered during the buildings life as the moisture content within the log boards changes. The boards will expand during periods of high moisture (Winter) and shrink during periods of low moisture (Summer.)

***Ensure the storm braces are secured at the highest point possible on each side.**

****Storm braces will help your building expand and contract properly.**

*****Important: Ensure each bolt is tightened using a washer so as not to damage the log boards.**

16x60mm Bolt Sets



60mm bolt

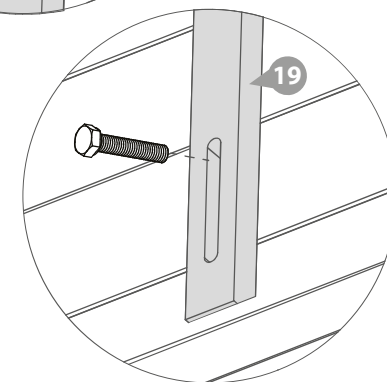
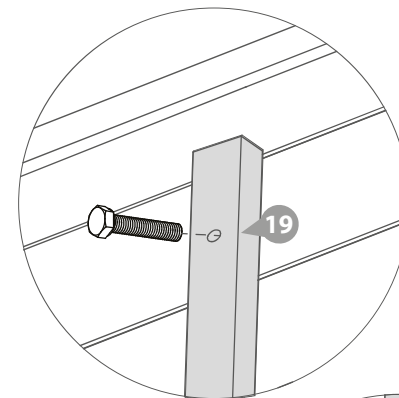

It is **ESSENTIAL** to seal around all window framing with silicone sealant (not included) to minimise water ingress.



It is ESSENTIAL that you apply wood treatment immediately after the building has been assembled.

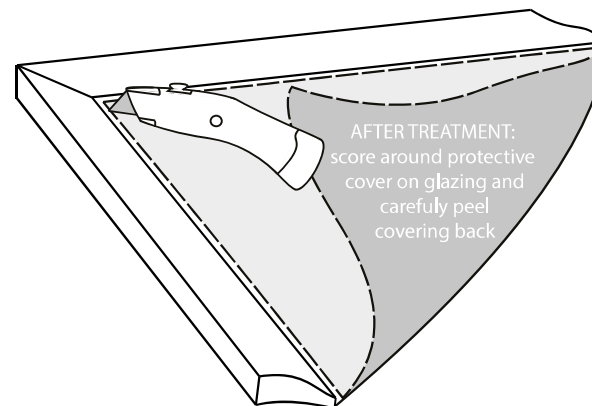

AFTER TREATMENT: score around protective cover on glazing and carefully peel covering back

