

**0619PNSH1203FBSD-V2**  
**19MM 1.2M X 3M PENT SHED ADD-ON.**

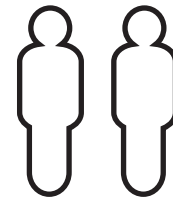

**x2**  
 All buildings should be erected by two adults.



Winter = High Moisture = Expansion  
 Summer = Low Moisture = Contraction

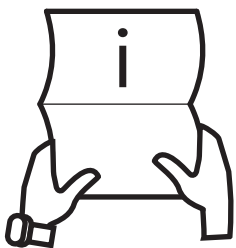

**BEFORE YOU START PLEASE READ THE INSTRUCTIONS CAREFULLY**

- Check the pack and make sure you have all the items listed in the parts list provided.
- When you are ready to start, make sure you have the right tools at hand (not supplied - see the equipment list on next page).
- Ensure there is plenty of space and a clean dry area for assembly.
- Ensure you have enough time to build the product to ensure the building is water tight.



**2mm Drill bit**

For ease of assembly, you **MUST** pilot drill all screw holes and ensure all screw heads are countersunk.



**CAUTION**

Every effort has been made during the manufacturing process to eliminate the prospect of splinters on rough surfaces of the timber. You are strongly advised to wear gloves when working with or handling rough sawn timber.

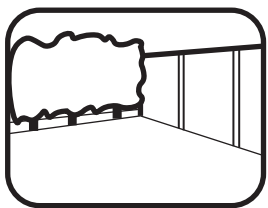

**LOCATION FOR YOUR GARDEN BUILDING**

A minimum of 600mm should be left around the perimeter of your garden building to allow access for maintenance, annual treatment and to allow air flow around the building.

Where possible you should avoid placing your garden building underneath large trees to prevent the tree causing damage to the building.

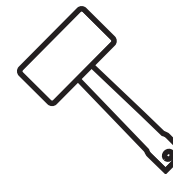

For ease of assembly use a rubber mallet to fit the log boards. Do NOT use a heavy hammer.



Ensure to measure and check dimensions of components and fixings before cutting.

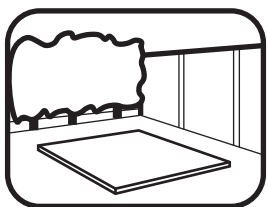

**BUILDING A BASE**

When thinking about where the building and where the base is going to be constructed: Ensure that there will be access to all sides for maintenance work and annual treatment. Ensure the base is level and is built on firm ground, to prevent movement. The base should be the same size as the building's floor bearer frame. These base dimensions are given on the first page of the contents. It is also recommended that the floor be at least 25mm above the surrounding ground level to avoid flooding.

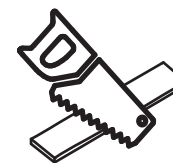

It is advisable to use a hand saw when cutting roof and floor boards.

Use a measuring tape to identify the fixings required for each step:

**Screws & Nails**

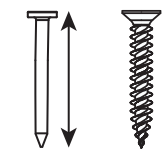

Measure overall length

**Bolts**

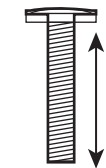

Measure under the head



To ensure log boards are even, use a spirit level to check each layer has been installed correctly.

**TYPES OF BASE**

- Concrete 75mm laid on top of 75mm hard-core.
- Slabs laid on 50mm of sharp sand.
- Wooden base - Levelled / on posts / ground screws.

**TREATMENT**

Once your garden building has been installed it will need to be treated within 14 days (weather permitting) and annually to prevent the timber from deteriorating and to waterproof it. This is required to maintain the anti-rot guarantee.

Log Cabins - Are supplied untreated and require a preservative and waterproofing treatment.

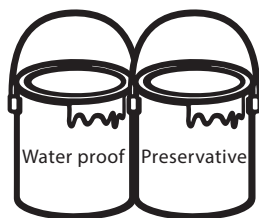

**TIMBER**

As with all natural materials, timber can be affected during various weather conditions. For the duration of heavy or extended periods of rain, swelling of the wood panels may occur. Warping of the wood may also occur during excessive dry spells due to an interior moisture loss. Unfortunately, these processes cannot be avoided but can be helped. It is suggested that the outdoor building is sprayed with water during extended periods of warm sunshine and sheltered as much as possible during rain or snow.

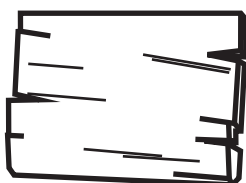

REGISTER FOR YOUR  
**10 YEAR**  
**ANTI-ROT**  
 GUARANTEE TODAY

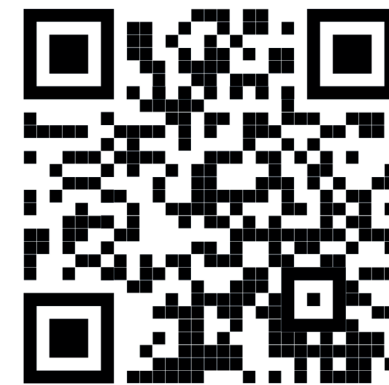

[www.mgplogistics.co.uk](http://www.mgplogistics.co.uk)

In all instances for assistance with your product or to register your anti rot guarantee, please contact us via our customer portal .

Mercia Garden Products Limited,  
 Sutton On Trent, Newark,  
 Nottinghamshire, NG23 6QN



Whilst all products manufactured are made to the highest standards of safety and in the case of children's products independently tested to EN71 level, we cannot accept responsibility for your safety whilst erecting or using this product.

## TO DO LIST

- Find a suitable location to build *(see front cover for further information)*.
- Build a base *(see front cover for further information)*.
- Check the base is flat, level, clear of debris and has 60cm clearance on all sides.
- Check you have the required equipment / tools.
- Check you have all the product items listed *(if you have missing or damaged parts please scan the QR code below to visit our online customer portal)*.
- Install the product as per the step by step instructions within this pack.
- Prepare the product ready for treatment (this may include sanding).
- Apply a preserving and a waterproofing treatment within 14 days of installation *(weather permitting)*.
- Register for your anti rot guarantee *(scan the QR below)*.
- Tidy the build area and dispose of any remaining parts responsibly.
- Maintain your building *(see the manufacturers recommendations at the back of this pack)*.

## EQUIPMENT LIST

- Hammer
- Mallet
- Flat Head Screwdriver
- Drill
- Drill Bit Set
- Phillips and Slotted Bit Sets
- Tape Measure
- Hand Saw
- Spirit Level
- Ladders/Steps
- Stanley Knife/Cutting Tool
- Sand Paper
- Gloves
- Silicone (For Windows Only)
- Sealant Application Gun
- Wood Filler (Optional)
- Timber Preservative Treatment
- Timber Water Proofing Treatment
- Treatment Mixing Stick
- Paint Brush/Sprayer/Roller

## NEED EXTRA SUPPORT

If you are unsure that your base preparation will be suitable, please contact us via our customer portal to discuss this further.

Alternatively, you can visit our website or MGP Logistics Online Portal for some further sheducation.

**Website:**

<https://www.merciagardenproducts.co.uk/sheducation>

**MGP Logistics Online Portal:**

<https://www.mgplogistics.co.uk/>

Here you will find plenty of useful information that'll help with most pre-installation and maintenance queries.

**ANY QUESTIONS?**

Scan the QR code to contact us via our customer portal.

## NOTES

## ACCESSING VIDEO GUIDES...

Some steps within this set of instructions come with an added video guide for your convenience. These can be accessed via the QR code and used to aid you in constructing that step. See below for how to use.

You can also find all the videos on our youtube channel:  
<https://www.youtube.com/@merciagardenproducts8716/videos>

### 1. Find the QR code within the instruction step...

#### Step.....

Parts Needed- No. QTY 1  
No. QTY 1  
No. QTY 1

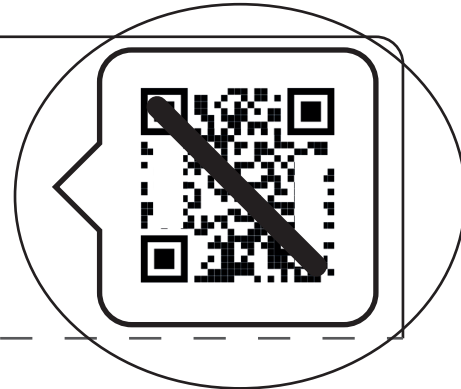

Within the instruction step, there will be an icon in the top right that has a QR code in. This is where the video can be accessed from.

*Please note: not every step has a video guide.*

### 2. Open camera app...

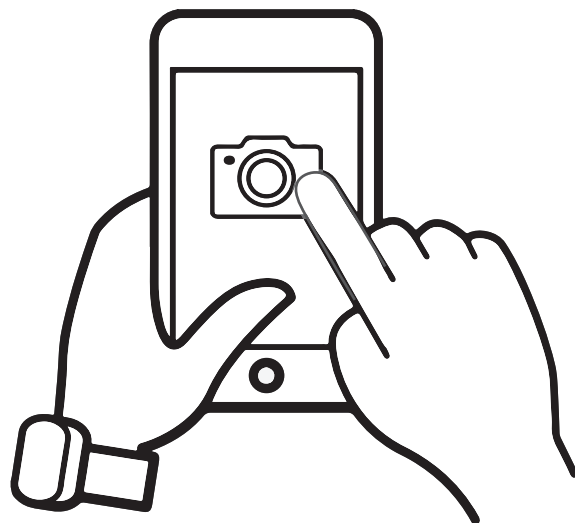

On your personal smart device (phone, tablet etc), open your camera app or QR code scanner app.

## ACCESSING VIDEO GUIDES...

### 3. Scan QR code...



To scan the QR code, hold the camera over the QR code so that it can be seen on the screen. Once the QR code has been registered, follow the prompts on your device to open the video. (This will vary depending on your device.)

*Please note: Ensure to use the back camera of your smart device as this will scan the QR code more accurately.*

### 4. Watch the video...

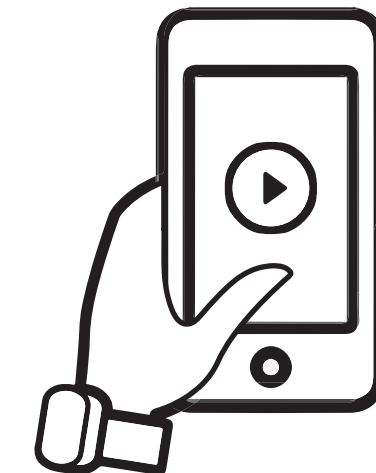

The video guide will now be displayed on your smart device.

**Disclaimer:** *The Log Cabin constructed in the video guides may be constructed differently to your building. Please ensure to read your instructions carefully to avoid error.*

## 0619PNSH1203FBSD-V2

**Overall Dimensions:** Width = 1214mm  
 Depth = 3326mm  
 Height = 2489mm



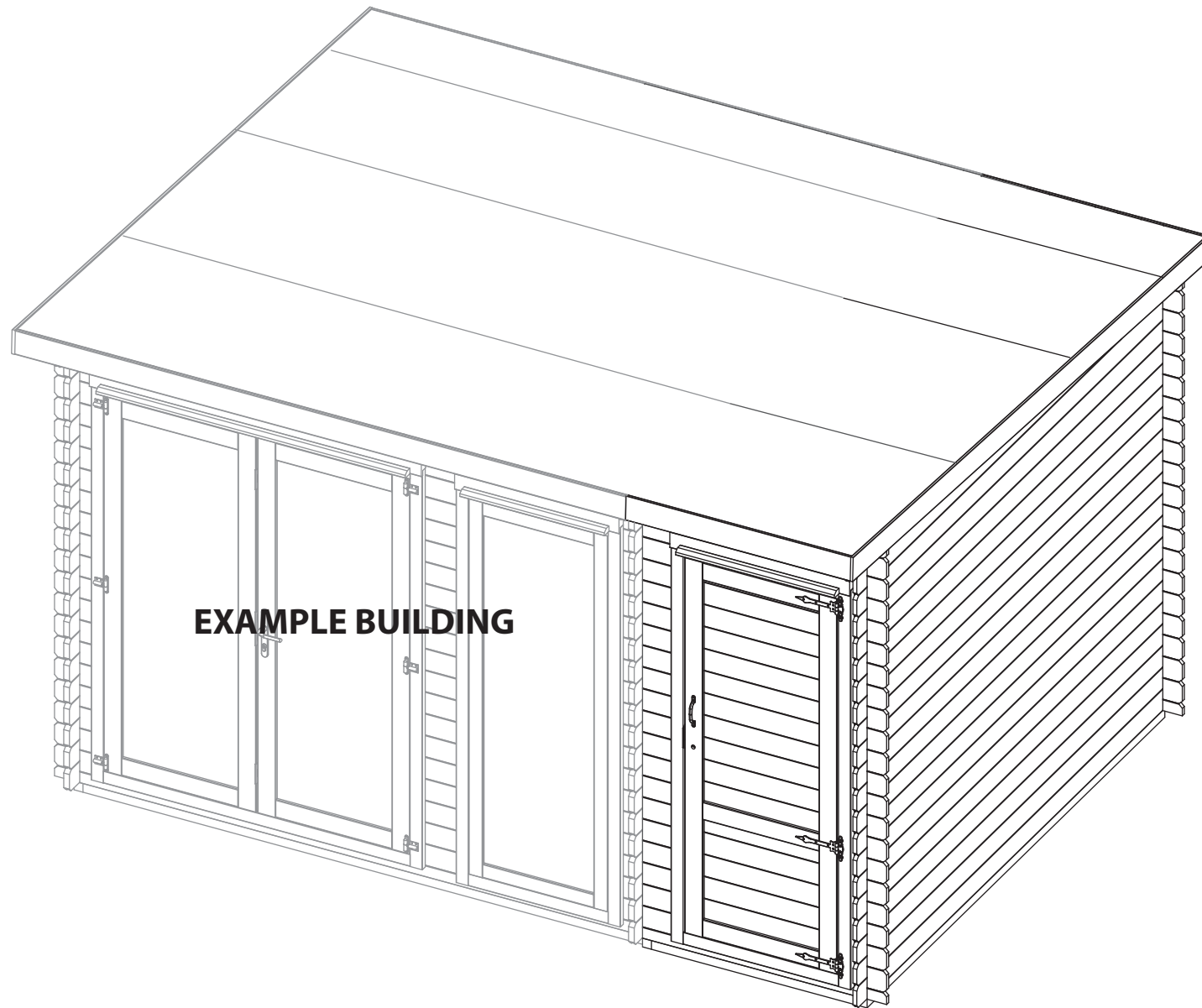

















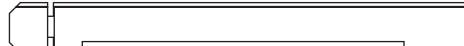

**Base Dimensions:** Width = 1104mm  
 Depth = 2773mm

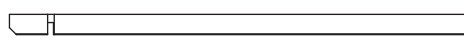

Tip: Labelling your parts, using a pencil and masking tape, may help you to identify them easier when you need them.

NO.1 STARTER BOARD

### Log Boards Contents:

- 
**1 Starter Board - 19x66x1176mm QTY 1**  
LB19RT66-B-1176mm

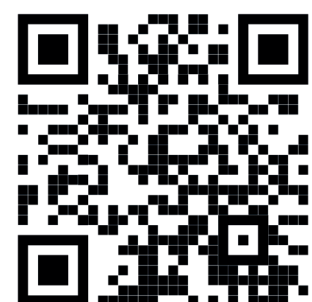
- 
**2 Starter Board - 19x66x1200mm QTY 1**  
LB19RT66-B-1200mm

- 
**3 Log Board - 19x120x2965mm QTY 20**  
LB19-A-2965mm

- 
**4 Log Board - 19x120x187mm QTY 18**  
LB19-B-187mm

- 
**5 Log Board - 19x120x187mm QTY 18**  
LB19-C-187mm

- 
**6 Log Board - 19x120x1200mm QTY 1**  
LB19-BD-1200mm (Door cut out)

- 
**7 Log Board - 19x120x1200mm QTY 2**  
LB19-B-1200mm

- 
**8 Log Board - 19x120x1176mm QTY 20**  
LB19-B-1176mm

- 
**9 Finisher Board - 19x54x1200mm QTY 1**  
LB19RG54-B-1200mm

- 
**10 Finisher Board - 19x52x1176mm QTY 1**  
LB19RG52-B-1176mm

- 
**11 Gable QTY 1**  
AI-0619PNSH1203FBSD-G-V1

- 
**12 Gable Point QTY 1**  
AI-0619PNSH1203FBSD-G-V1









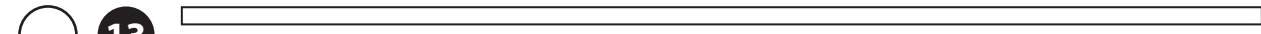
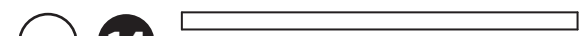
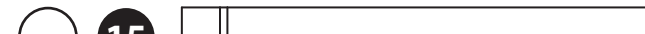

### Missing parts?

Scan the QR code to visit our customer portal where you can quickly raise any missing or damaged parts and get a replacement sent out ASAP.





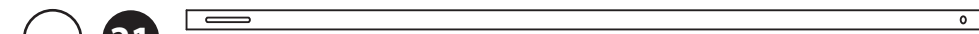
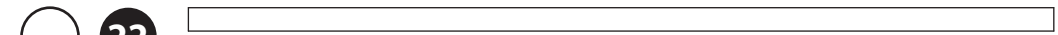
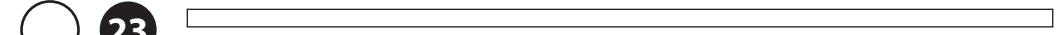





### Fixing Kit Contents:

- 
**13 Floor Bearer - 44x44x2773mm QTY 2**  
F4444-2773mm-PT
- 
**14 Floor Bearer - 44x44x1016mm QTY 10**  
F4444-1016mm-PT
- 
**15 Purlin - 45x120x1202mm QTY 2**  
F4090-B-1202mm
- 
**16 Roof Board - 12x121x3300mm QTY 11\***  
MB12-3300mm
- 
**17 Floor Board - 12x121x2731mm QTY 11\***  
MB12-2731mm
- 
**18 Eaves Frame - 27x44x1104mm QTY 2**  
F2744-1104mm
- 
**19 Fascia - 12x120x1150mm QTY 2\***  
S12120-1150mm
- 
**20 Closure Trim - 16x28x2400mm (approx length) QTY 3\***  
S1628-2400mm
- 
**21 Storm Brace - 44x27x2000mm QTY 6**  
F2744-2000mm
- 
**22 Strip - 16x60x2222mm QTY 1**  
S1660-2222mm
- 
**23** End View 

**\*This part will be longer than needed and requires cutting to size when used. This will be explained when required within the instruction step.**

**Note: one piece may be required to be cut into multiple different sizes. Do not dispose of off-cuts until the building is fully constructed as they may be needed in another step.**

### Fixing Kit Contents:

- 
**24 Plastic Vent QTY 4**  
PI-07-0237
- 
**25 2mm Spacer QTY 5**  
PI-07-0208 (20x100x2mm)
- 
**26 Sand Capping Felt**
- 
**27 Sand Felt**
- 
**28 Green Felt**
- 
**29 Butyl QTY 2**  
PI-01-0042

**\*Sand and Green Felt are not provided and will not be provided if upgraded Felt has been ordered.**

### Fully Boarded Door Contents:

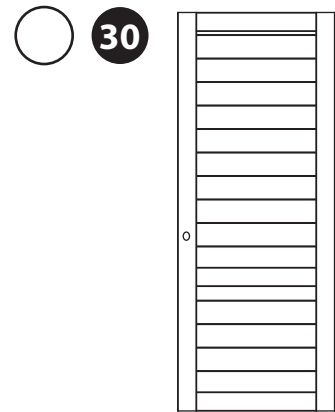

30

**Fully Boarded Single Door QTY 1**

AI-06LOGFBD750X1900-V3

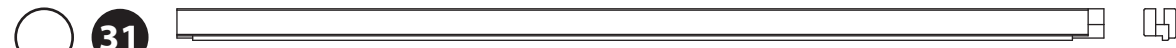

31

**Door Frame Left Upright - 71x70x2065mm QTY 1**

AI-0619LOGDUFL-V3



32

**Door Frame Right Upright - 71x70x2065mm QTY 1**

AI-0619LOGDUFR-V3



33

**Door Frame Top - 81x125x884mm QTY 1**

AI-0619LOGSDTF-V3



34

**Door Frame Bottom - 71x70x764mm QTY 1**

AI-0619LOGSDBF-V3



35

**Rain Guard - 28x44x780mm QTY 1**

RG2844-780mm

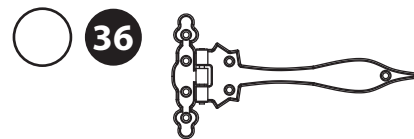

36

**T-Hinge QTY 3**

PI-07-0002

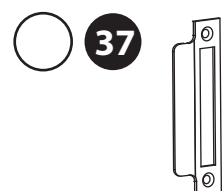

37

**Key Plate QTY 1**

PI-07-0200

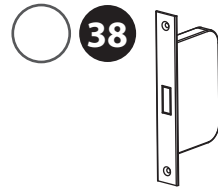

38

**Dead Lock QTY 1**

PI-07-0200

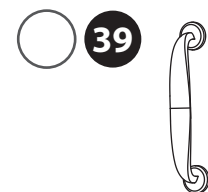

39

**Door Handle QTY 1**

PI-07-0033

### Screw Pack.

There may be extra screws present in the pack.



**60mm Bolt Set x 12**



**30mm Screw x 66**



**80mm Screw x 8**



**30mm Black Screw x 31**



**70mm Screw x 67**



**20mm Screw x 4**



**40mm Screw x 138**



**Felt Tacks x 200**

### Pre-assembly

**\*Please note:**

Each board interlocks at either end in a staggered pattern.

Before securing ensure that the boards are fitted properly in their respective tongue's and groove's.

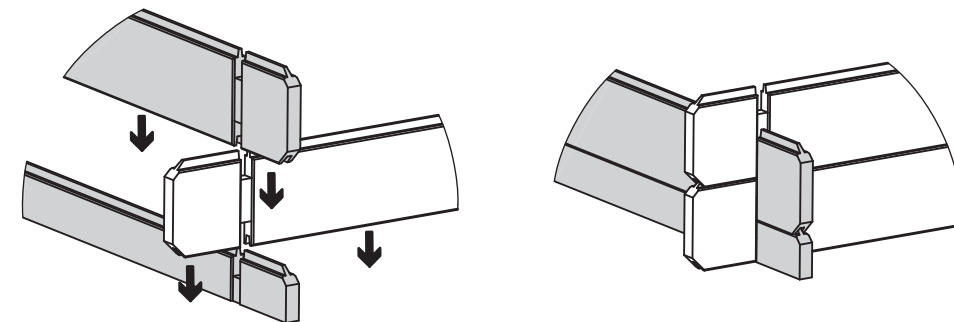

### Pre-Assembly

Before beginning construction of your side shed, please follow the instructions to construct your chosen log cabin, however **DO NOT** attach or cut down the last roof board, Felt or the Fascia trims. Not attaching these parts allows the extension to be fixed in place.

Your building should look as shown:

(0619PNNE0303HGDD2SW-V2)

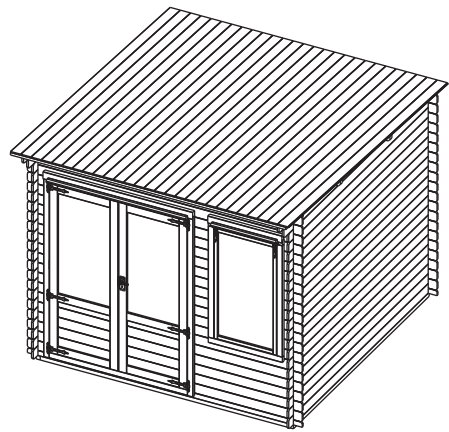

(0619PNNE0403HGDD3SW-V2)

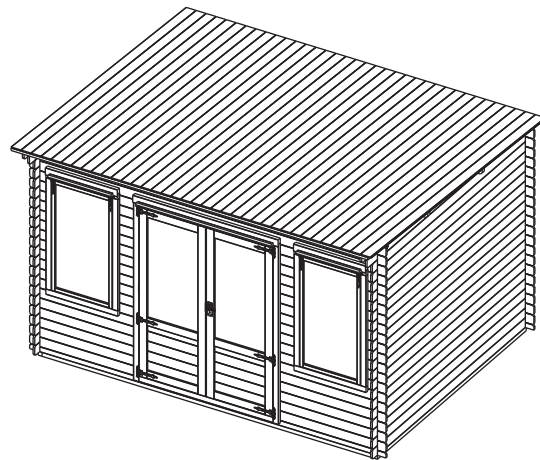

(0628PNNE0303HGDD1SW-V1)

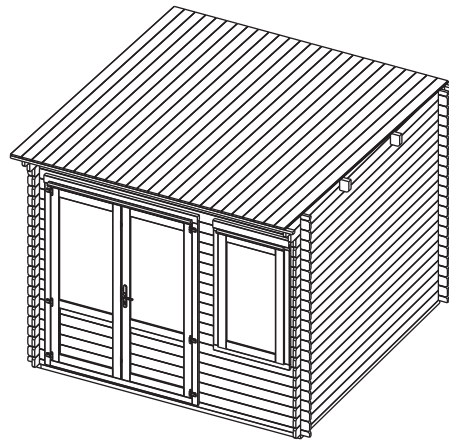

(0628PNNE0303FGDD3TW-V1)  
(0634PNNE0303FGDD3TW-V1)  
(0644PNNE0303FGDD3TW-V2)

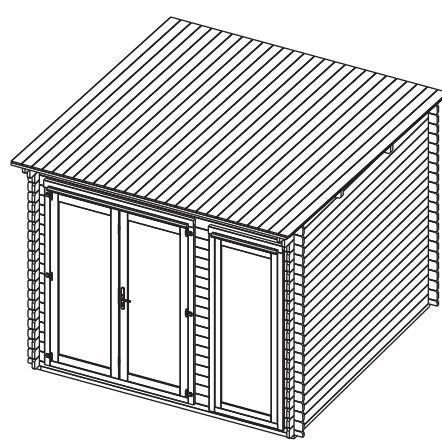

(0628PNNE0403FGDD4TW-V1)  
(0634PNNE0403FGDD4TW-V1)  
(0644PNNE0403FGDD4TW-V1)

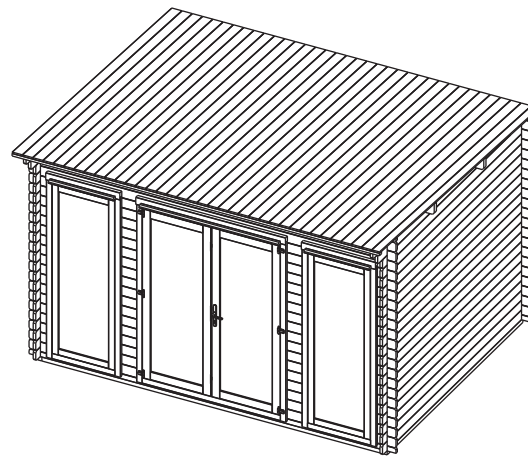

(0644PNUPVC0303FGDD3TW-V1)

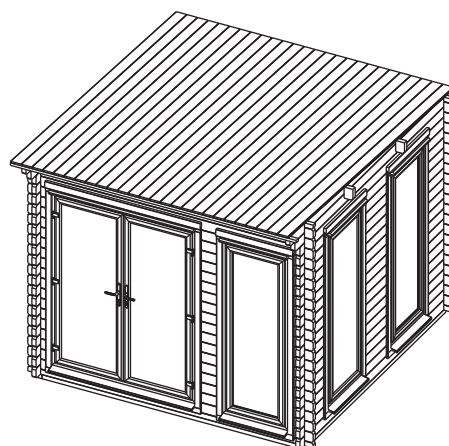

(0644PNUPVC0403FGDD4TW-V1)

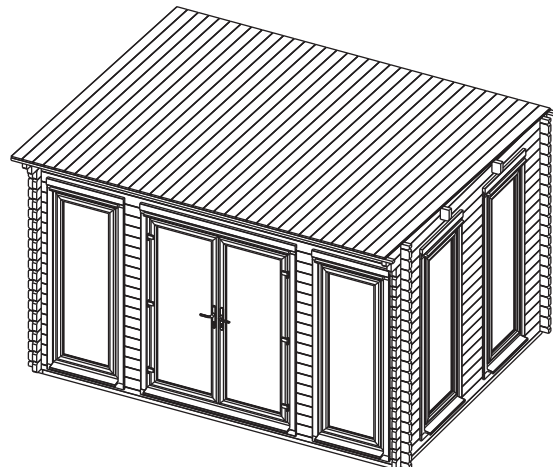

**Before assembly, please make sure you have a suitable base ready to install your building onto.**

### Step 1

**Parts Needed - No. 13 QTY 2**

**No. 14 QTY 2**

Lay the bearers (**No. 13 & 14**) onto a firm and level base (*free from areas where standing water can collect*) ensuring the bearers are level and flush as shown.

Fix the bearers together at each corner using 2x70mm screws per corner.

Once fully assembled, ensure the bearers are square by measuring from corner to corner as illustrated, making sure the measurements are equal. If the bearers are not aligned equally, unscrew, adjust and re-align accordingly.

**8x70mm screws**

**Important:** Pre-drill before fixing screws.



Spirit level



Tape Measure



Drill / Pre drill



70mm screw

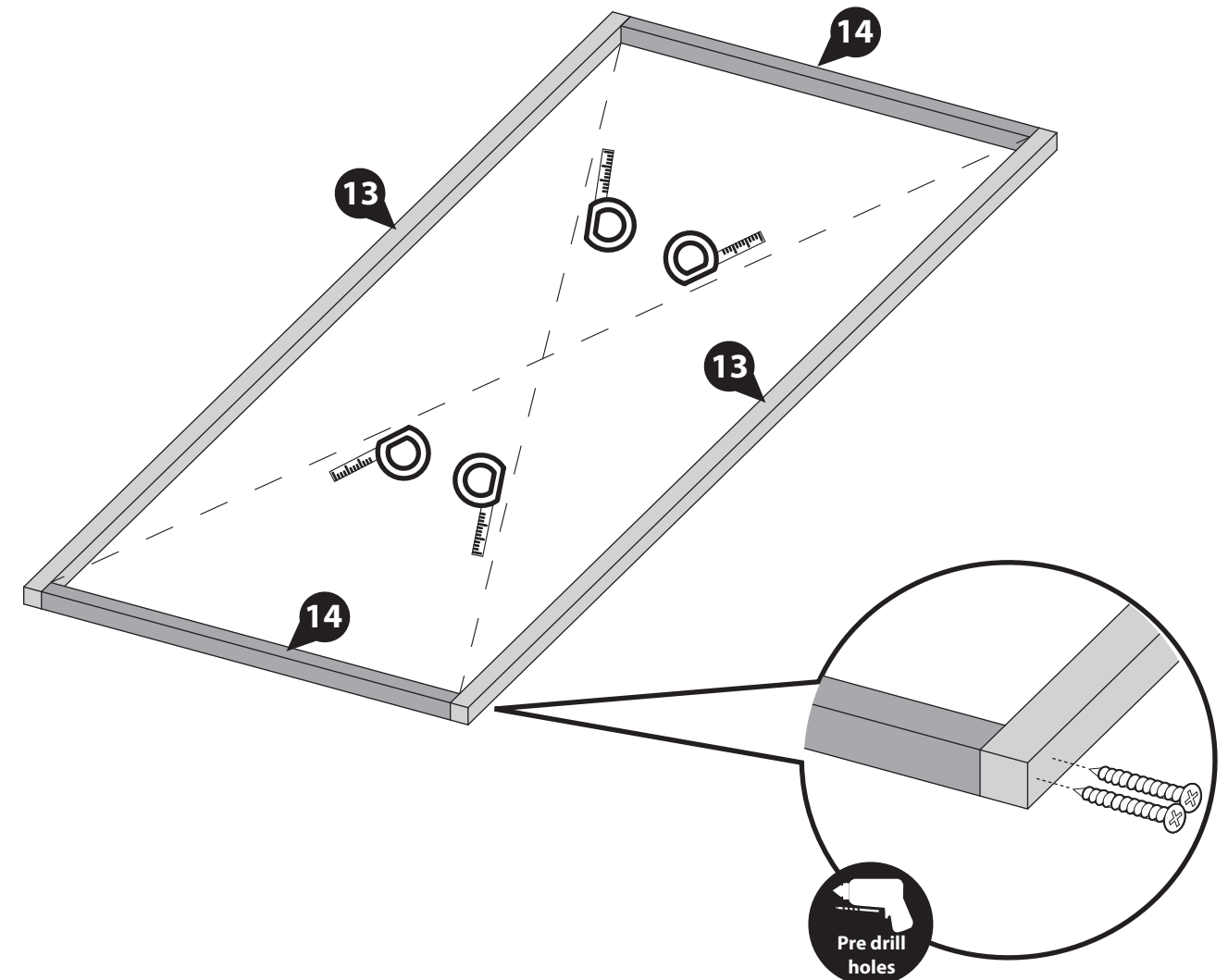



## Step 2

### Parts Needed - No. 14 QTY 8

Following the same method, arrange the remaining bearers (No. 14) inside the assembled frame, ensuring each piece is flush and level.

**\*Ensure there is an equal amount of space between each bearer.**

Secure each of the bearers in place by screwing through the outside framing into the framing behind using 2x70mm screws for end side of the bearer, as shown.

### 32x70mm screws

**Important:** Pre-drill before fixing screws.

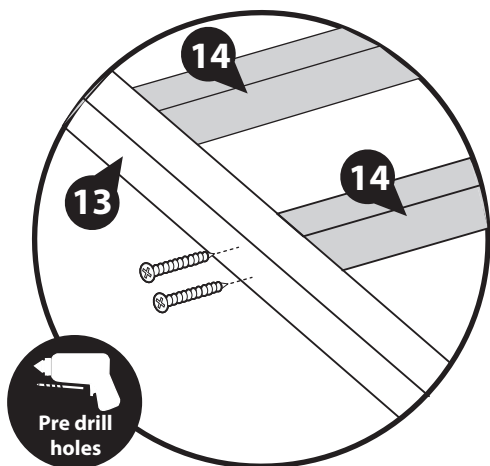
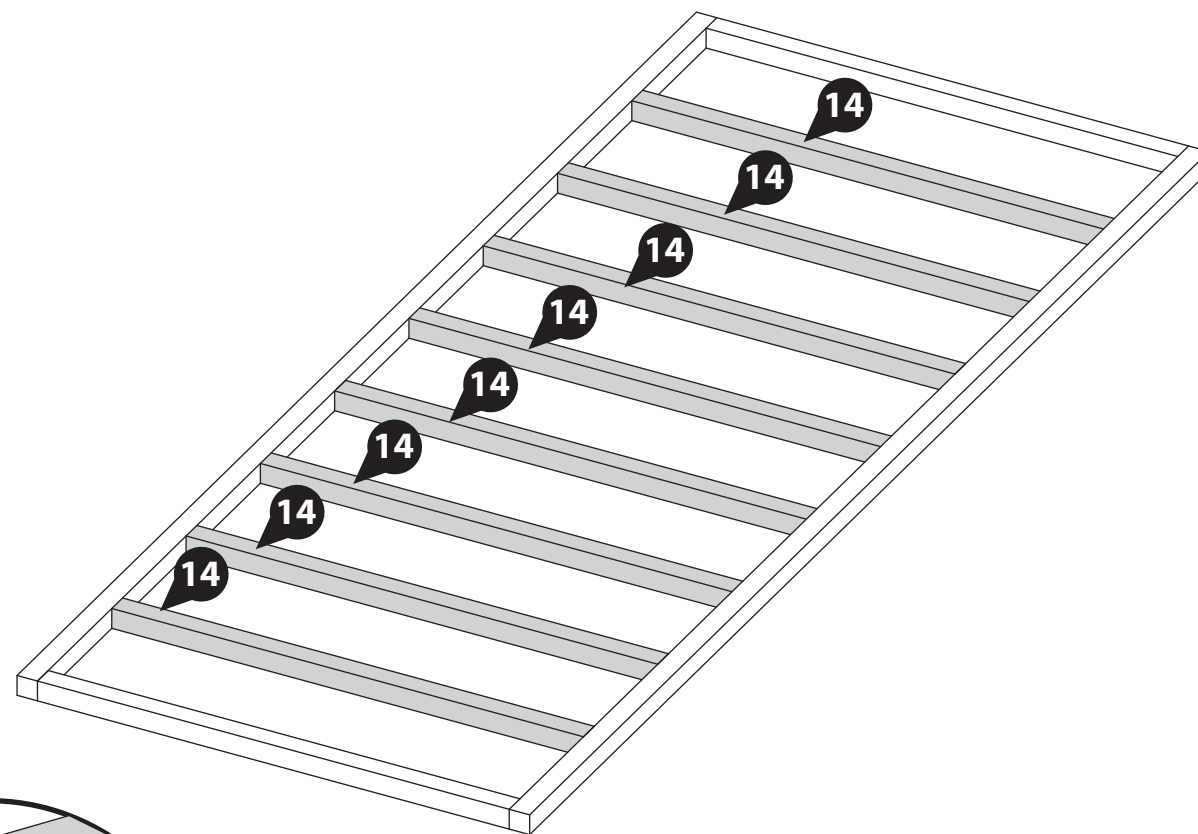
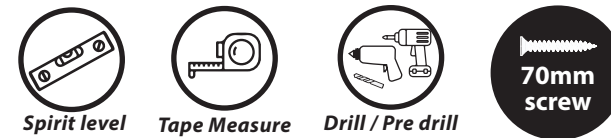

## Step 3

**\*Please note:** The Log cabin used in the step is for illustrative purposes only and may differ from your choice in building, however the process of aligning the bearers is the same.

Place the assembled Bearers up against the bearers of the Log Cabin. At the front of the building, ensure the bearers sit 19mm in front of the log cabin's log board, as shown. The Bearers will not be level with the log cabin's bearers at the back.

**\*Please note:** At the back of the log cabin, there will be a gap between the log cabin bearers and the shed bearers, as shown in the illustration.

Secure the shed bearers to the log cabin bearers using 9x70mm screws, as shown.

**\*Please note:** For illustrative purposes the shed will be constructed on the right hand side of the log cabin however you can position the Shed on either side of the log cabin, depending which side you attach the bearers.

### 9x70mm screws

**Important:** Pre-drill before fixing screws.

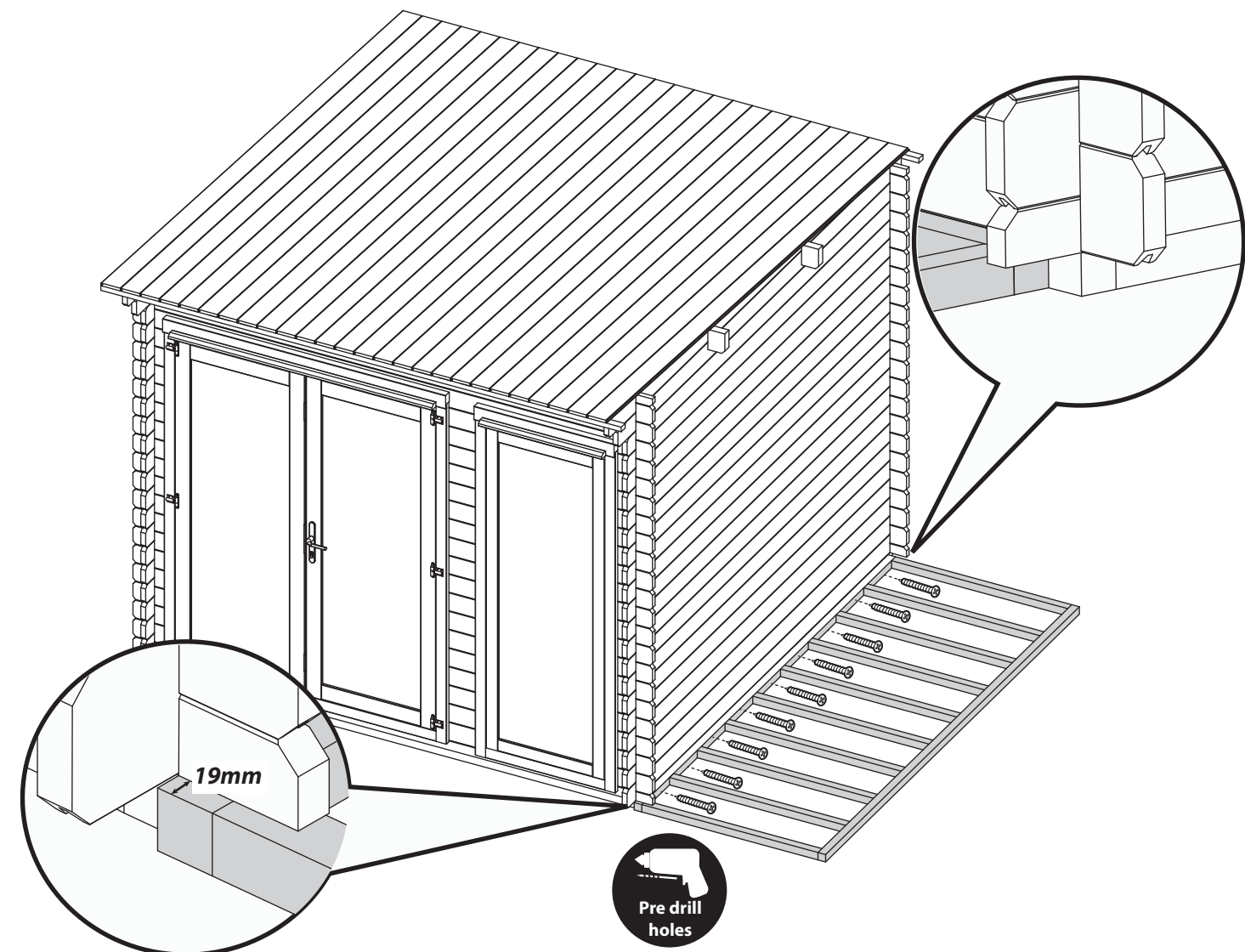
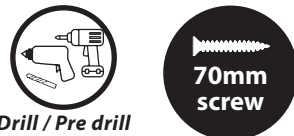

**Step 4**

**Parts Needed - No. 22 QTY 1**  
**No. 23 QTY 1**

Place the 'L Frame' (**No.23**) and the Strip (**No. 22**) flush together, creating a 'U' shaped channel, as shown in the illustration.

Fix together using 6x30mm screws.

**6x30mm screws**  
**Important:** Pre-drill before fixing screws.

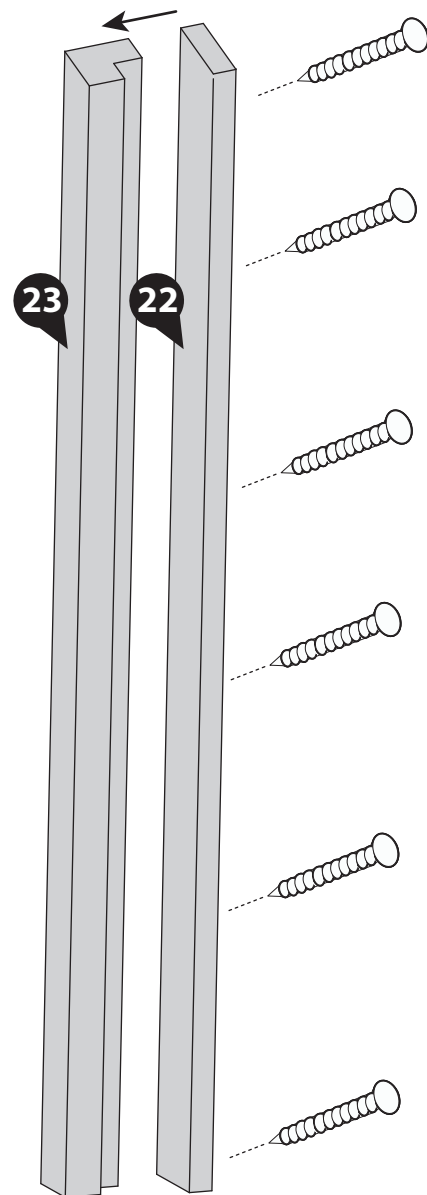
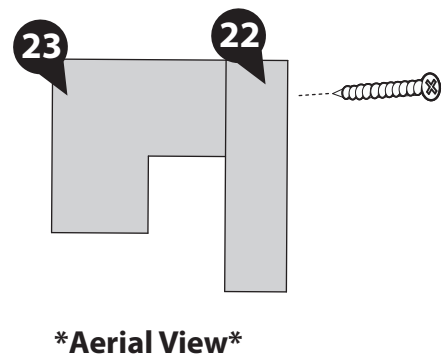

**Step 5**

**Parts Needed - No. 1 QTY 1**  
**No. 2 QTY 1**  
**No. 3 QTY 1**

Place the starter boards (**No. 1 & 2**) on to the assembled base frame along the front and the back, and lightly position the first log board (**No. 3**) on the notches as shown. Ensure the starter board (**No. 2**) sits in front of the log cabin's log boards.

**Note:** Use a mallet and a scrap piece of wood to gently fix the log boards into position.

Locate the 'U' Channel (if you have not yet constructed your 'U' channel please refer to Step 4) so it is flush to the side of the log cabin's log boards, and the 'U' channel sits around the starter board (**No. 1**).

The starter board (**No.1**) should sit flush to the back of the back bearer, and the back strip of the 'U' channel should overhang this bearer, as shown in the illustration.

Depending on the board thickness of your log cabin, there may be a gap between the back of the U-channel and the log cabins log boards.

**\*\*Ensure the measurement between the 'U' channel and log cabins log boards is equal at the top and bottom of the 'U' channel.**

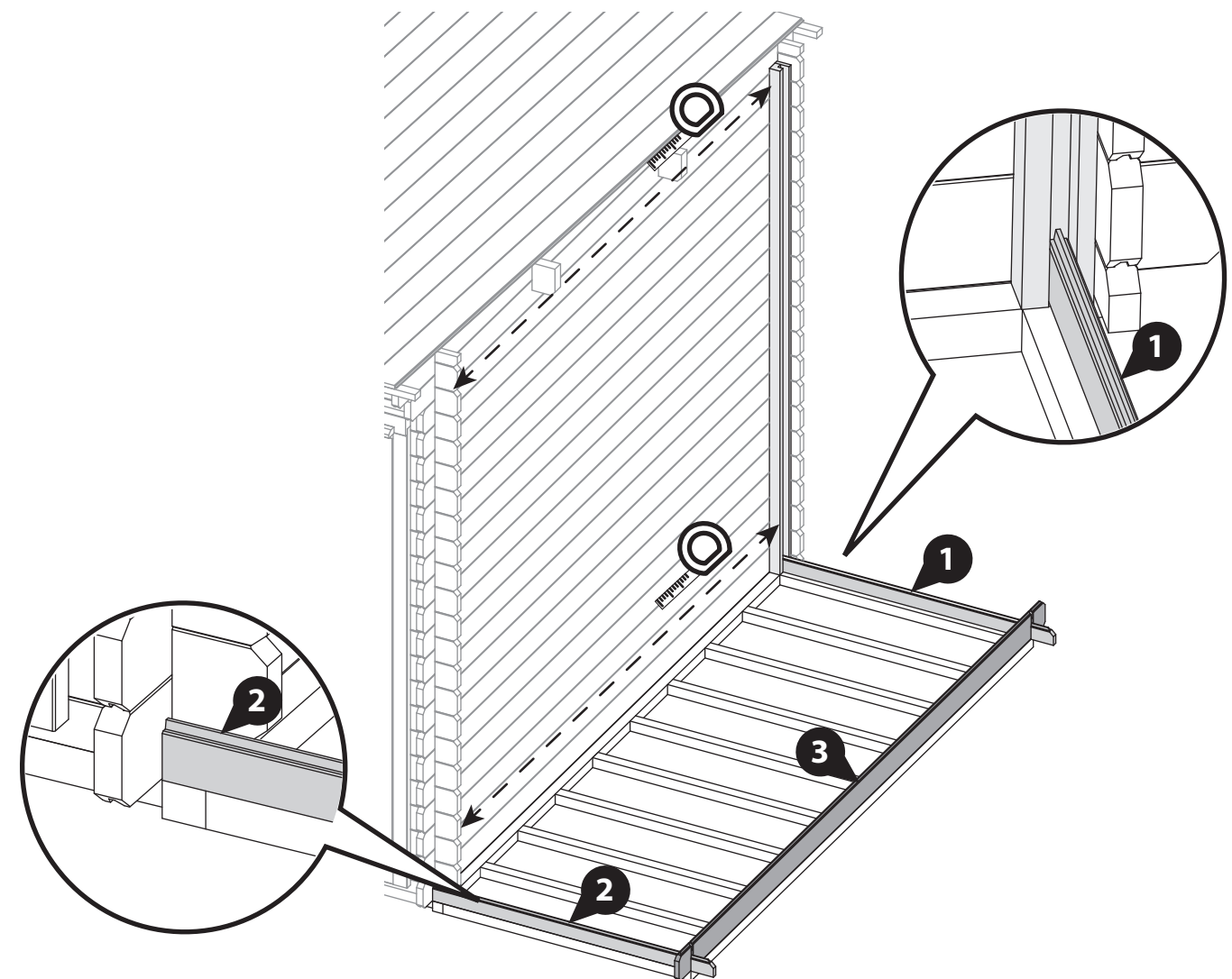



### Step 6

- Parts Needed - No. 1 QTY 1**  
**No. 2 QTY 1**  
**No. 3 QTY 1**

Ensure the boards sit square on the base using the same method used in Step 1. Measure corner to corner, making sure the measurements are equal.

Once the boards are square, lift up the log board (**No. 3**) and fix the starter boards (**No. 1 & 2**) in place by screwing through the notches into the bearer using 1x70mm screw per notch, as shown in the illustration.

To further secure the boards, fix the front starter board (**No. 2**) to the front log board of the log cabin. Screw straight through the starter board into the log cabin's board behind using 2x30mm screws, as shown in the illustration.

- 2x70mm screws**  
**2x30mm screws**

**Important: Pre-drill before fixing screws.**

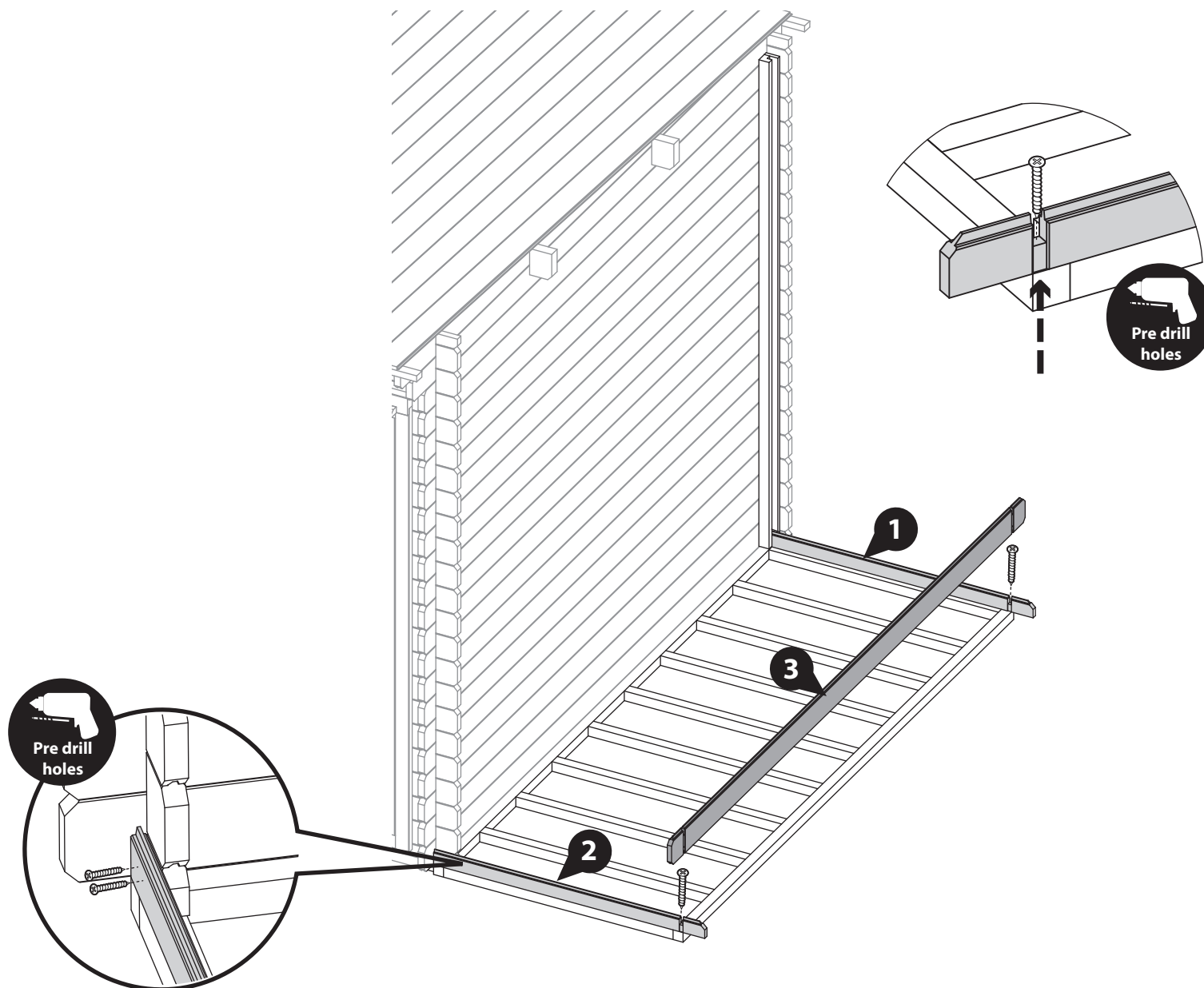

### Step 7

Fix the 'U' channel in place by screwing through the 'L frame' into the log boards behind using 6x30mm screws.

**\*\*Ensure the measurement between the 'U' channel and log cabins log boards is equal at the top and bottom of the 'U' channel.**

Depending on the board thickness of your log cabin, there may be a gap between the back of the U-channel and the log cabins log boards.

- 6x30mm screws**

**Important: Pre-drill before fixing screws.**

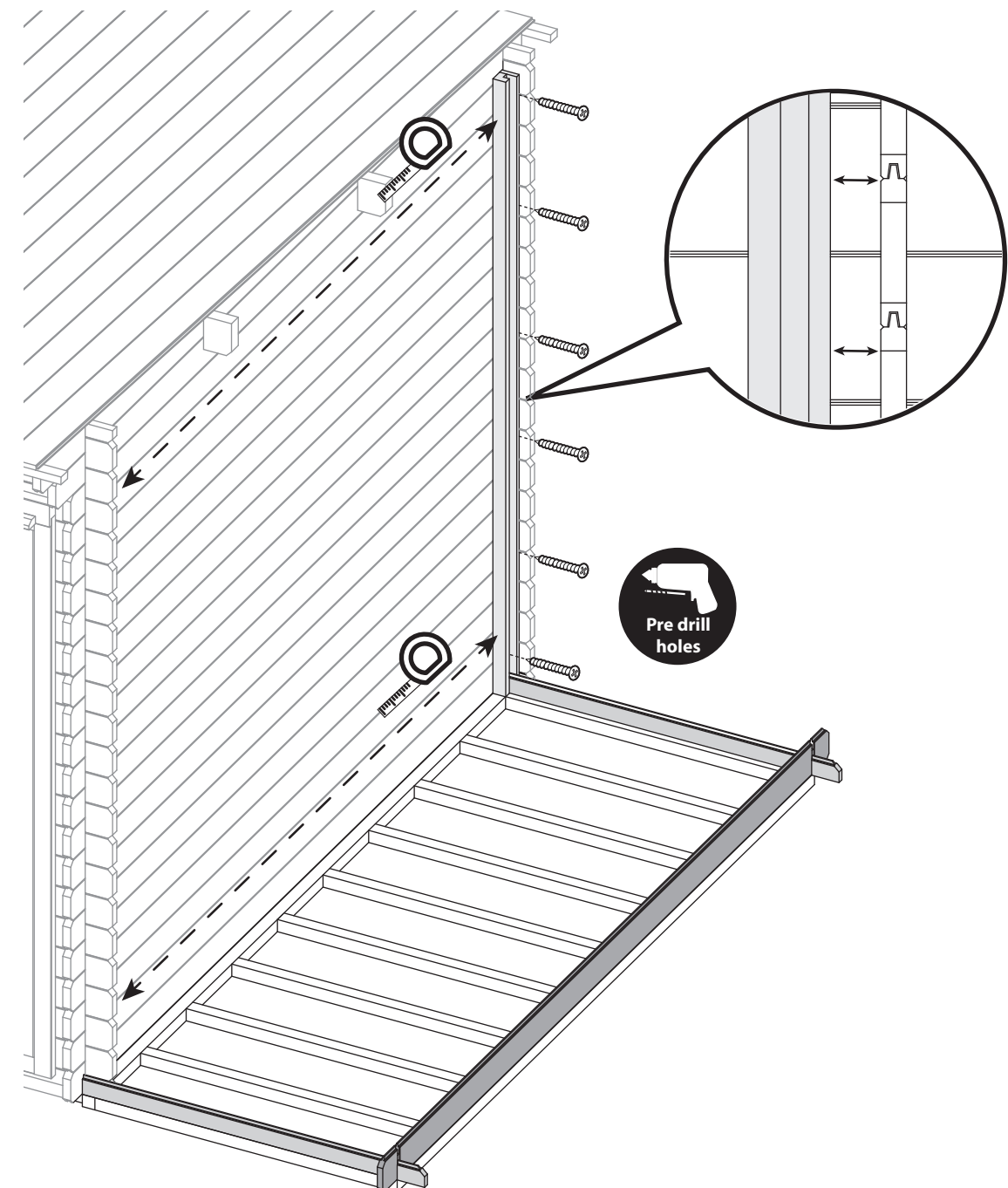

**Step 8**

- Parts Needed - No. 3 QTY 6
- No. 4 QTY 6
- No. 5 QTY 6
- No. 8 QTY 6

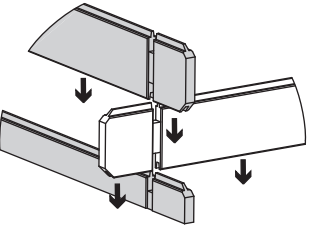

Following the method shown in the illustration, lay the first 6 boards (No. 3, 4, 5 & 8) off of the starter boards to create your first level, ensuring that the back log boards (No.8) sit inside the 'U' channel.

*\*Ensure that the boards are level and flush with each other as you lay each one.*

Secure the front top board (No.5) by screwing straight through the log board into the log board of the cabin behind using 2x30mm screws, as shown in the illustration.

Secure the back top board (No.8) by screwing through the Log board at an angle into the 'U' channel, using 2x30mm screws.

**4x30mm screws**  
**Important:** Pre-drill before fixing screws.

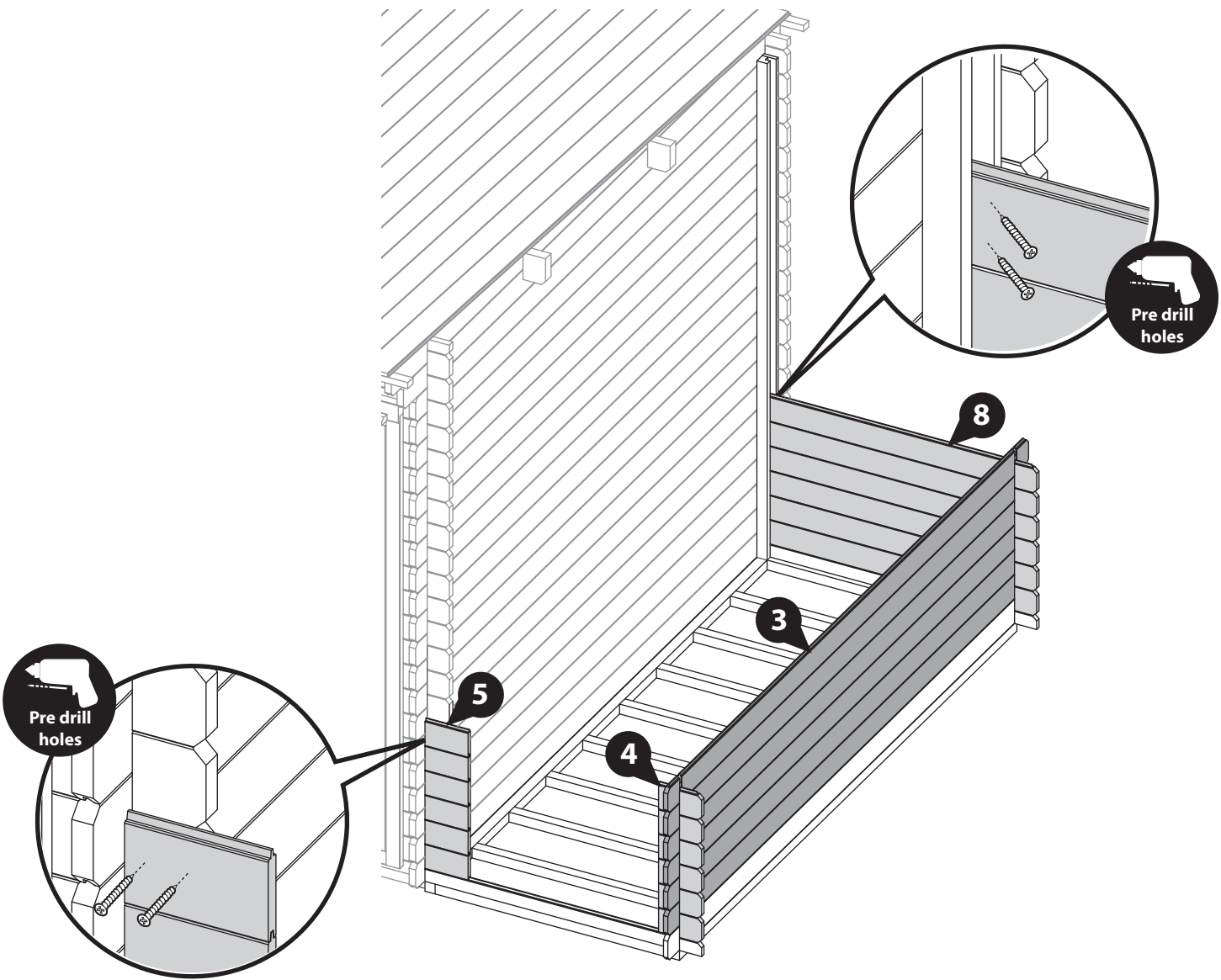

**Step 9**

- Parts Needed - No. 31 QTY 1
- No. 32 QTY 1
- No. 33 QTY 1
- No. 34 QTY 1

Arrange the left, right, top & bottom door frames (No. 31, 32, 33 & 34) onto a firm and level surface. Secure the top and bottom frames to the uprights using 2x80mm screw per corner, ensuring the screws do **NOT** protrude through the front of the door framing.

**8x80mm screws**  
**Important:** Pre-drill before fixing screws.

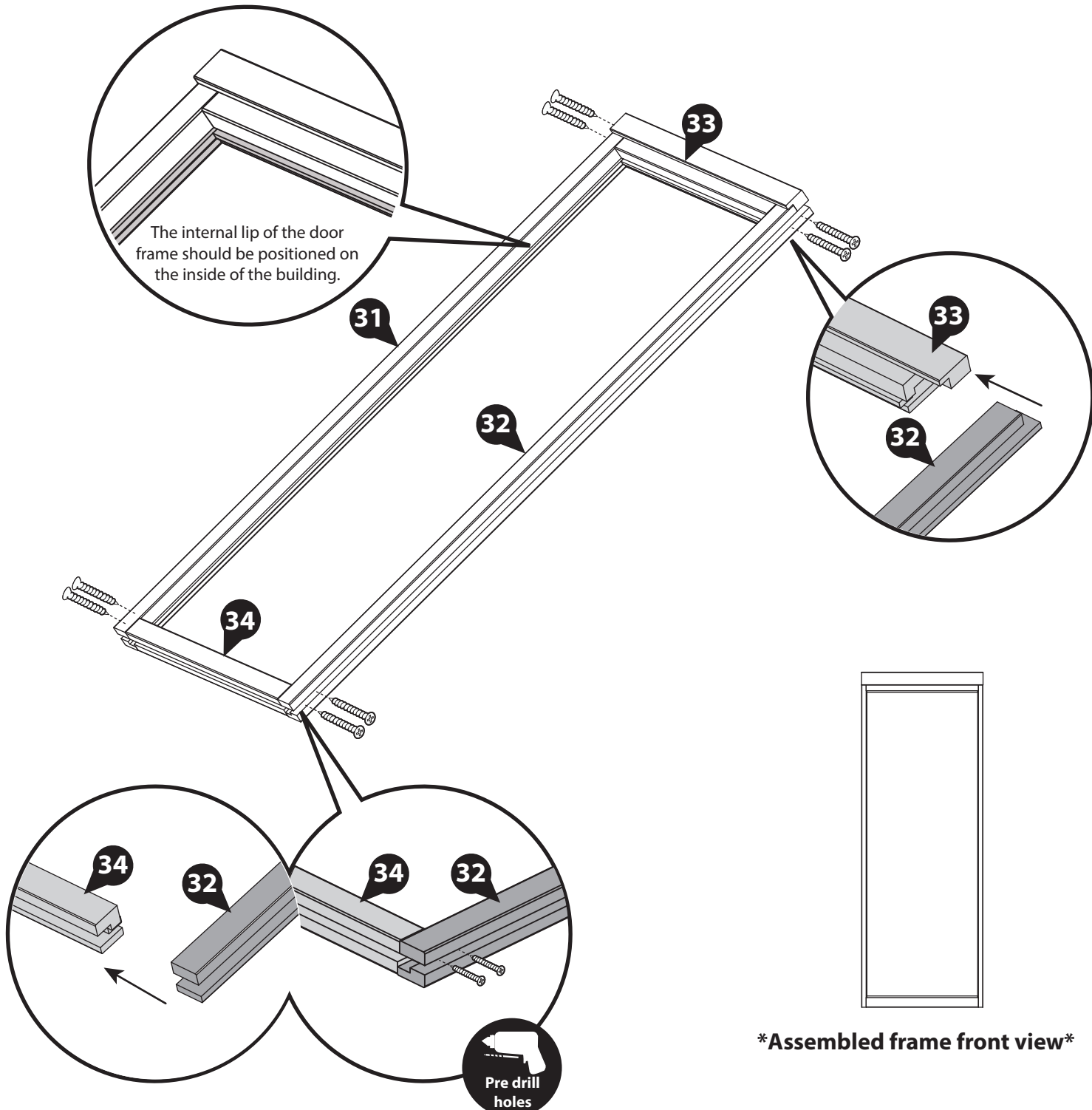

**\*Assembled frame front view\***

### Step 10

Once you have laid 6 log boards (off of the starter), slide the assembled door frame over the boards, resting the frame on top of the starter board (**if you have not yet assembled the door frame refer to Step 9**)



Rubber Mallet

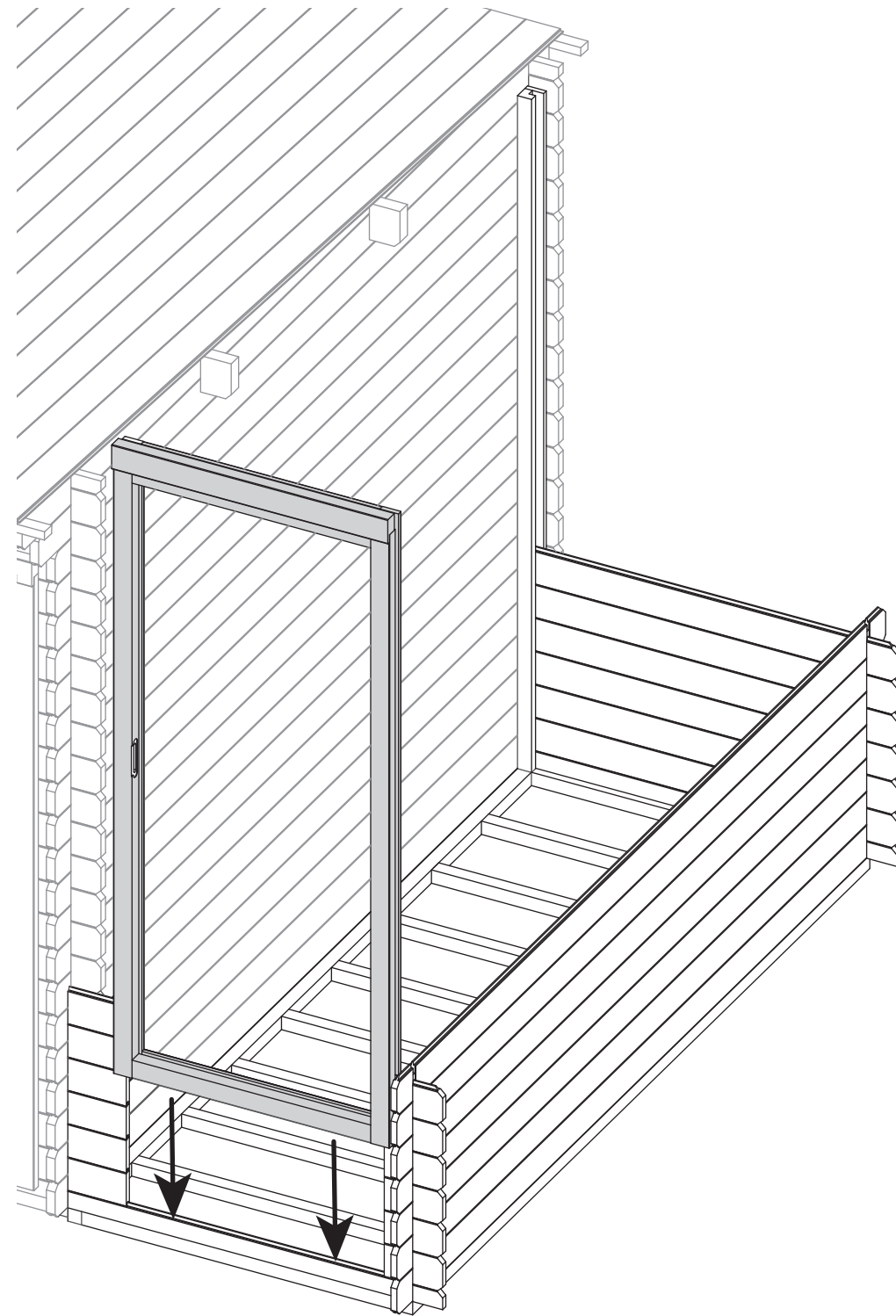

### Step 11

**Parts Needed - No. 5 QTY 12**

Lay the remaining boards (**No.5**) onto the shed between the log cabin and door frame, ensuring they sit in the groove of the door frame.

**\*Ensure that the boards are level and flush with each other as you lay each one.**

Fix every 6th board (**No.5**) to the Cabin's log boards, using 2x30mm screws as shown in the illustration.

**4x30mm screws**

**Important: Pre-drill before fixing screws.**

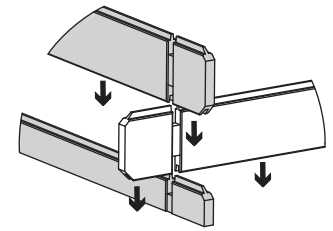

Rubber Mallet



Drill / Pre drill



30mm screw

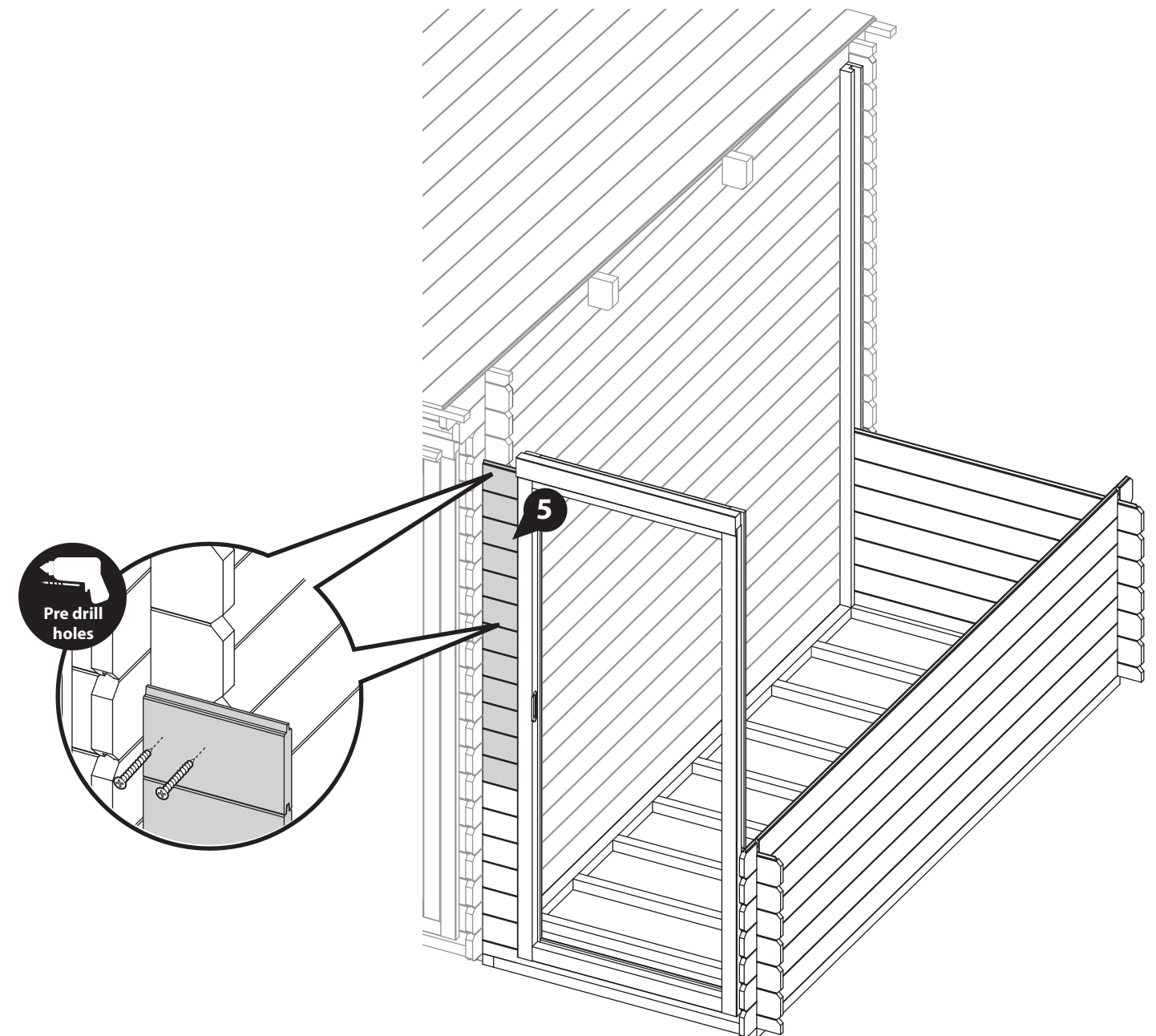



**Step 12**

**Parts Needed - No. 3 QTY 6**  
**No. 4 QTY 6**  
**No. 8 QTY 6**

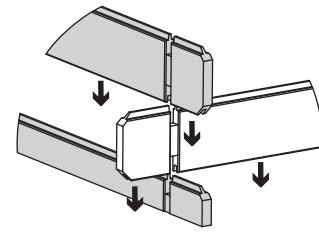

Following the method shown in the illustration, lay the next 6 boards (**No. 3, 4 & 8**) onto the shed to create your second layer, ensuring that the back log boards (**No.8**) sit inside the 'U' channel.

*\*Ensure that the boards are level and flush with each other as you lay each one.*

Secure the back top board (**No.8**) by screwing through the Log board at an angle into the 'U' channel, using 2x30mm screws.

**2x30mm screws.**  
**Important:** Pre-drill before fixing screws.

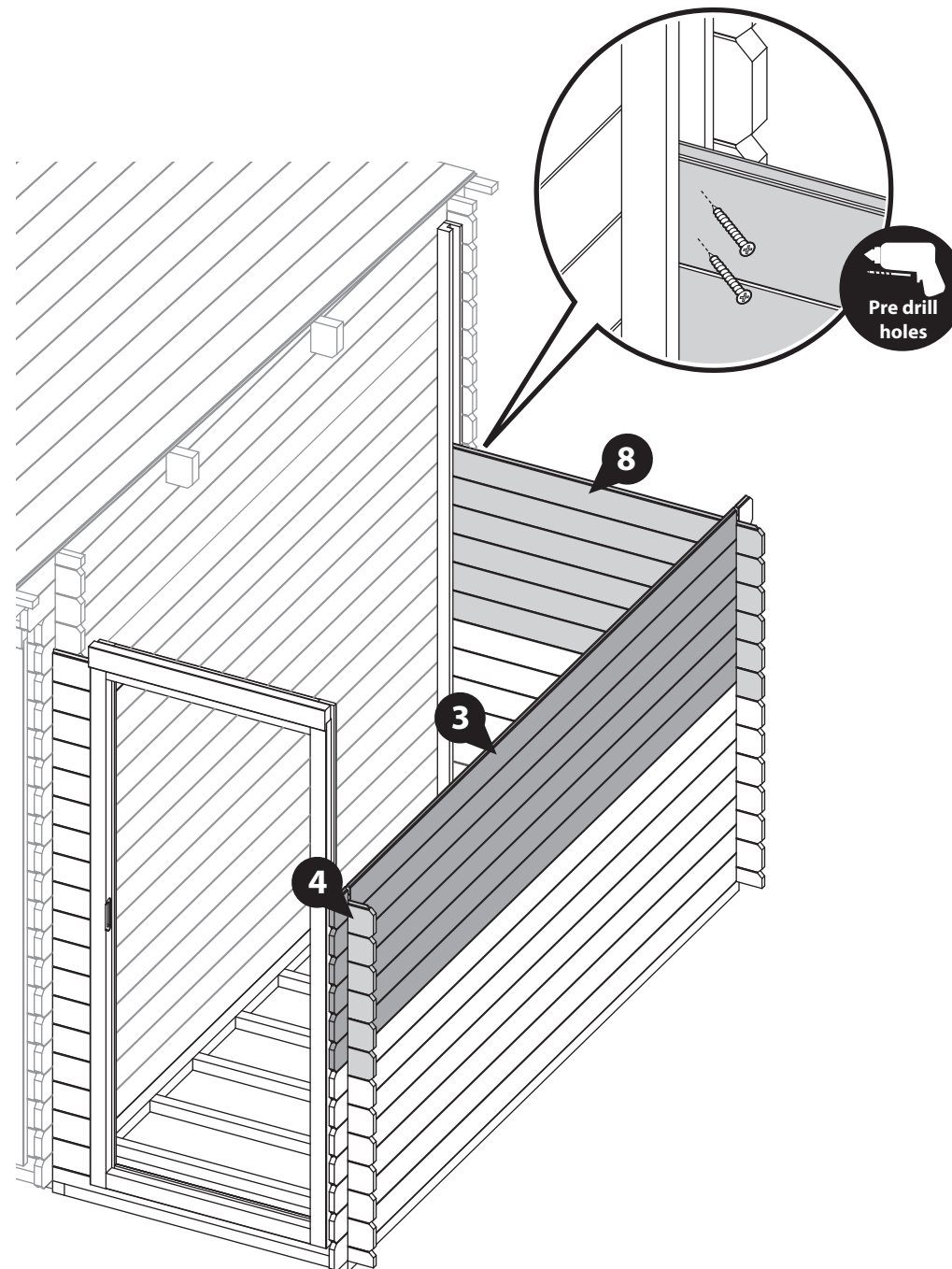

**Step 13**

**Parts Needed - No. 3 QTY 6**  
**No. 4 QTY 6**  
**No. 8 QTY 6**

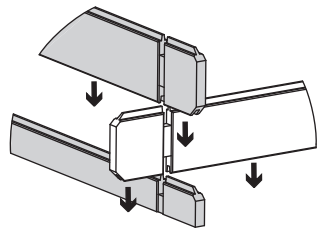

Following the method shown in the illustration, lay the next 6 boards (**No. 3, 4 & 8**) onto the shed to create your second layer, ensuring that the back log boards (**No.8**) sit inside the 'U' channel.

*\*Ensure that the boards are level and flush with each other as you lay each one.*

Secure the back top board (**No.8**) by screwing through the Log board at an angle into the 'U' channel, using 2x30mm screws.

**2x30mm screws**  
**Important:** Pre-drill before fixing screws.

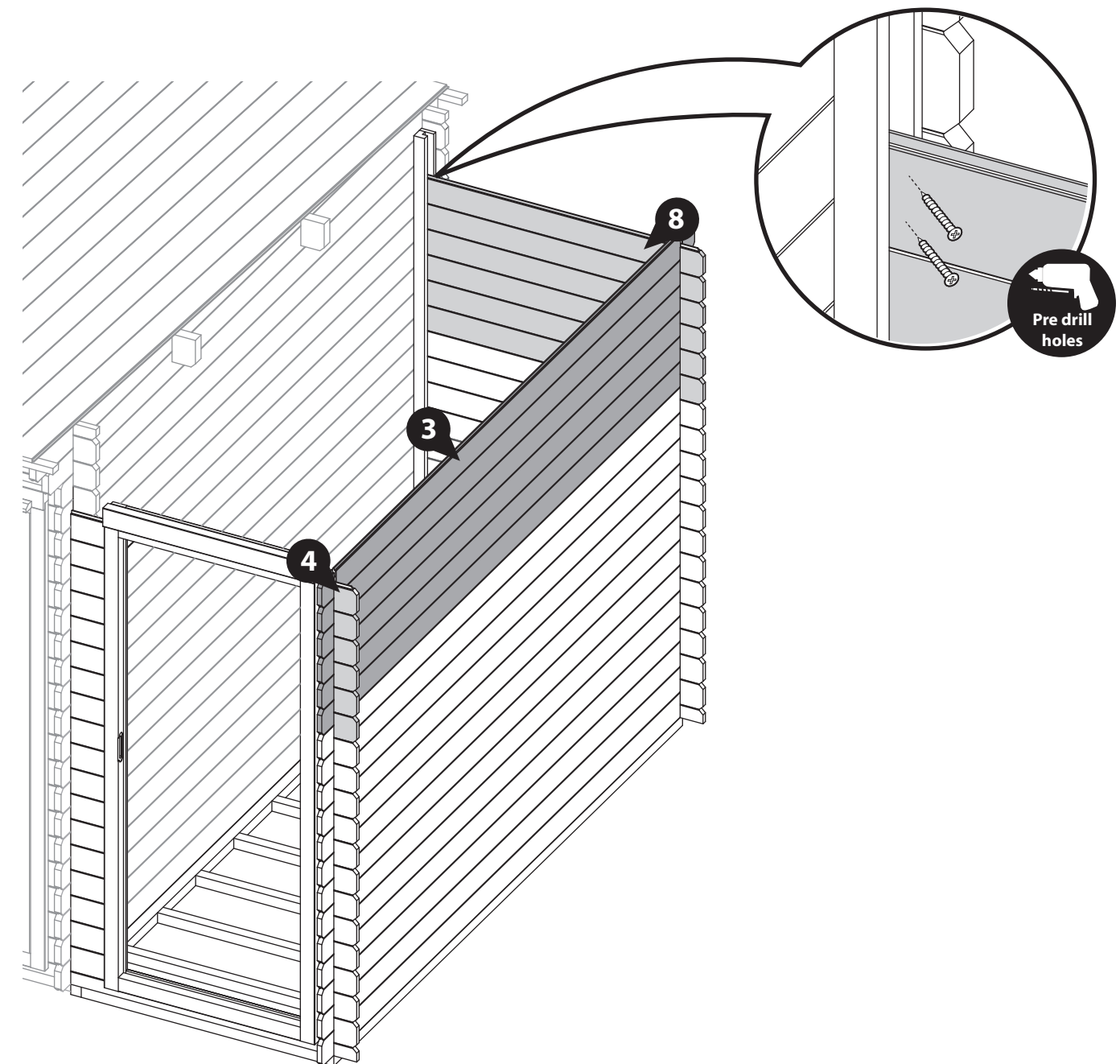

**Step 14**

**Parts Needed - No. 3 QTY 1  
No. 6 QTY 1  
No. 8 QTY 1**

Following the method shown in the illustration, lay the next layer of boards (**No. 3, 6 & 8**) onto the shed, ensuring that the back log board (**No.8**) sits inside the 'U' channel.

**\*Ensure that the boards are level and flush with each other as you lay each one.**

Fix the top board (**No.6**) to the log board of the cabin, using 2x30mm screws, as shown in the illustration.

Secure the back top board (**No.8**) by screwing through the Log board at an angle into the 'U' channel, using 2x30mm screws.

**4x30mm screws**

**Important: Pre-drill before fixing screws.**

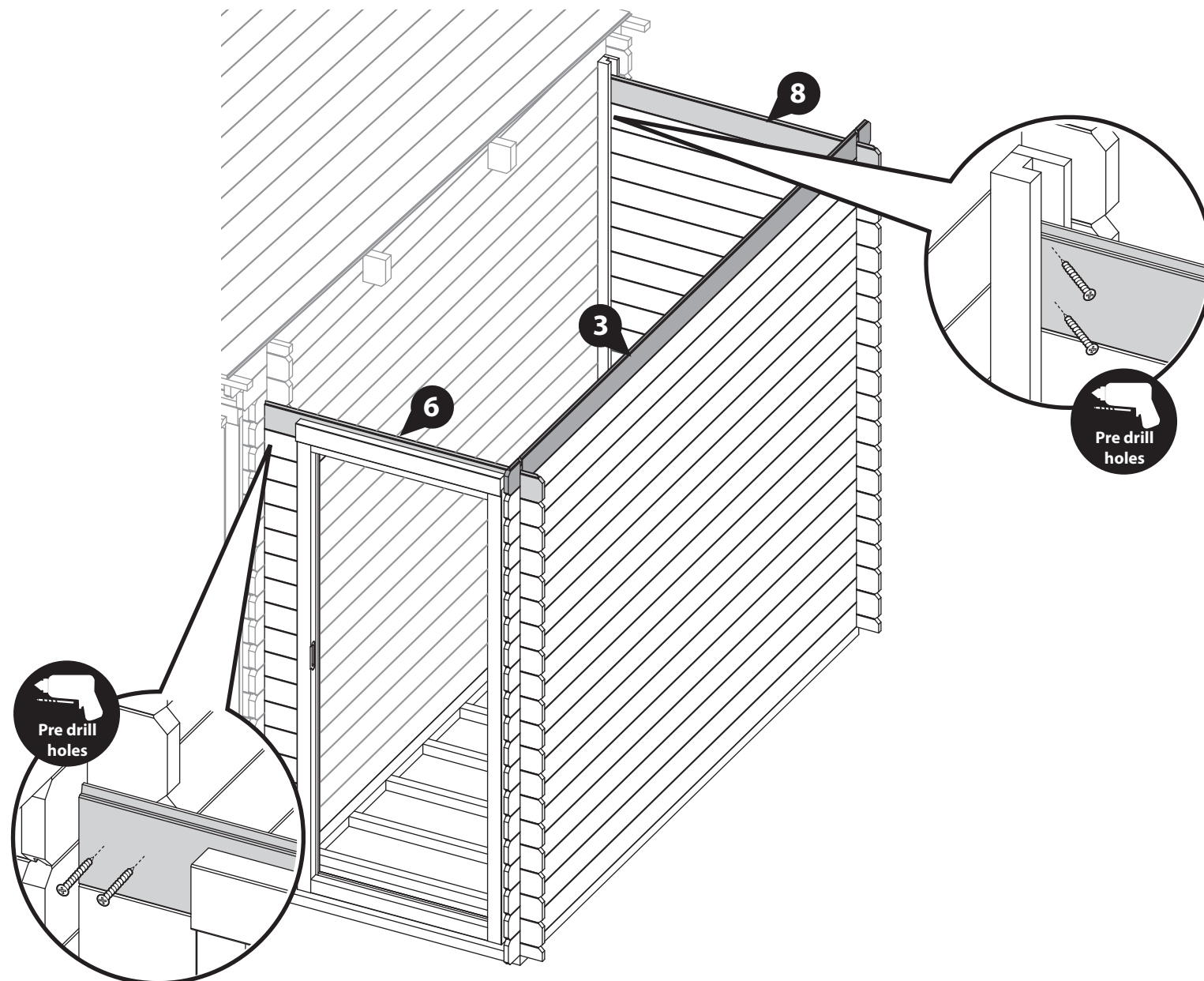
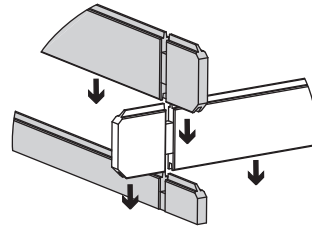

**Step 15**

**Parts Needed - No. 11 QTY 1  
No. 24 QTY 2**

Lay the Gable (**No. 11**) onto a flat and level surface and locate one Vent (**No. 24**) into each vent hole, as shown. Secure in place using 2x20mm screws per Vent.

Flip the Gable (**No. 11**) over and position the remaining Vent (**No. 24**) into the opposite side of the Vent holes. Fix in place using 2x20mm screws per vent.

On one side of each gable, the vent will need to be slightly offset to an angle to ensure the screws do not collide.

**4x20mm screws**

**Important: Pre-drill before fixing screws.**

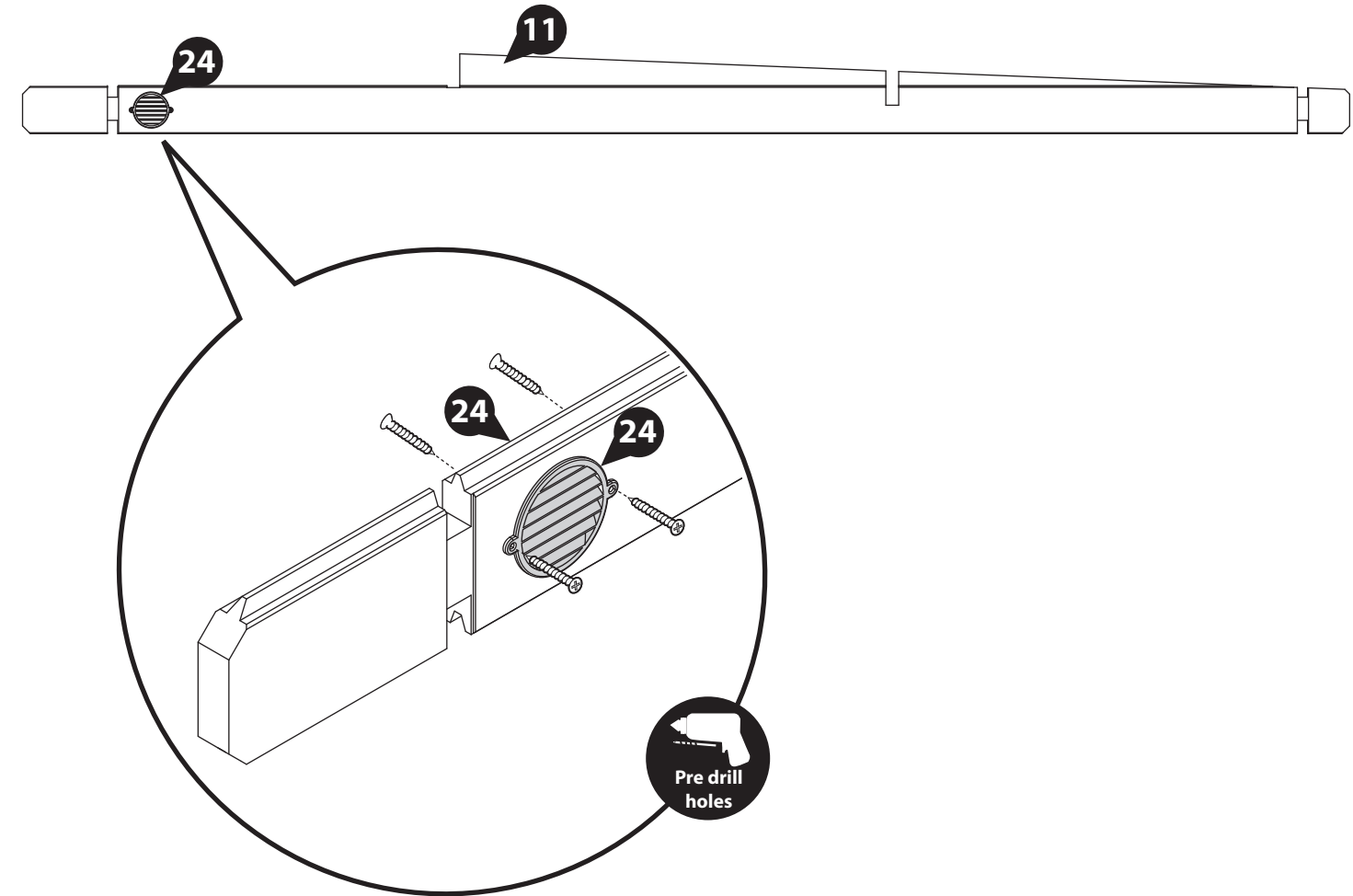



### Step 16

Parts Needed - No. 7 QTY 1  
 No. 8 QTY 1  
 No. 11 QTY 1

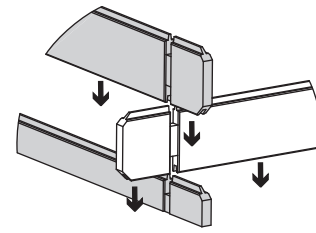

Following the method shown in the illustration, lay the next layer of boards (**No. 7 & 8**) and the Gable (**No. 11**), ensuring that the back log board (**No.8**) sits inside the 'U' channel.

**\*Ensure that the boards are level and flush with each other as you lay each one.**

Fix the top front board (**No.7**) to the Cabin's log board, using 2x30mm screws, as shown in the illustration.

Secure the back top board (**No.8**) by screwing through the Log board at an angle into the 'U' channel, using 2x30mm screws.

Fix the Gable (**No. 11**) to the boards below by screwing through the notch using 1x70mm screw per notch, as shown.

4x30mm screws  
 2x70mm screws

**Important:** Pre-drill before fixing screws.

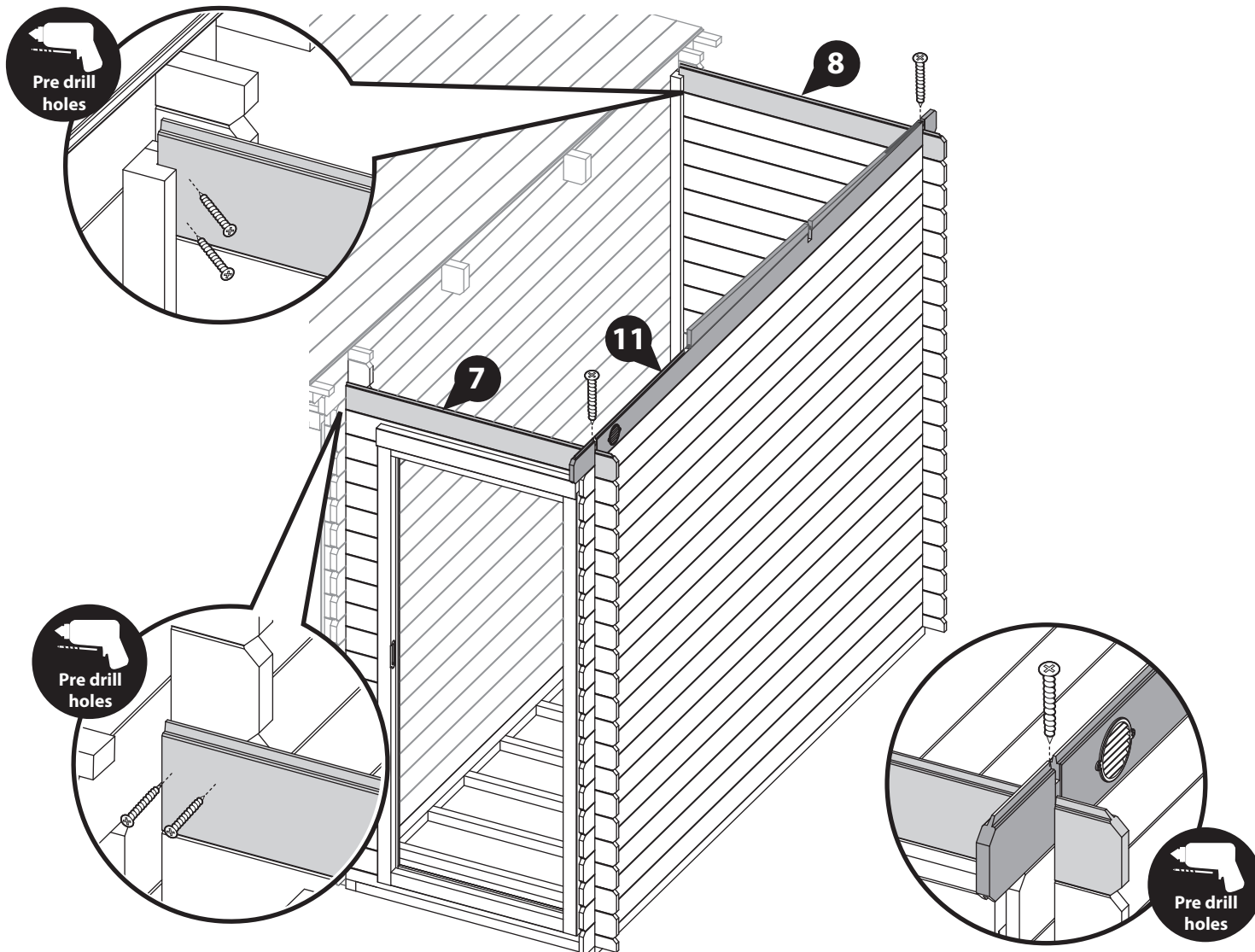
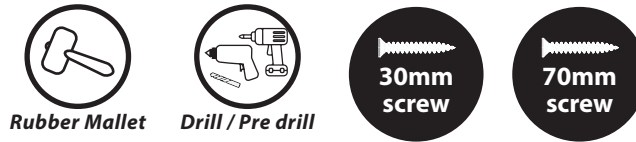

### Step 17

Parts Needed - No. 7 QTY 1  
 No. 10 QTY 1  
 No. 12 QTY 1

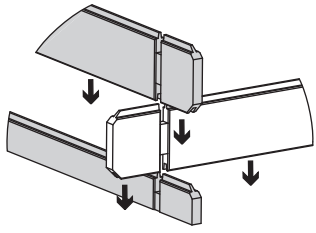

Following the method shown in the illustration, lay the next layer of boards (**No. 7 & 10**) and the Gable Point (**No. 12**). The back board (**No.10**) will sit above the top of the 'U' Channel. This allows for the timbers natural movement over time.

**\*Ensure that the boards are level and flush with each other as you lay each one.**

Fix the front Log board (**No.7**) to the Cabin's log board, using 2x30mm screws, as shown in the illustration.

Fix the Gable Point (**No. 12**) and the Finisher Board (**No.10**) to the board below by screwing through the notch using 1x70mm screw per notch, as shown.

2x30mm screws  
 2x70mm screws  
**Important:** Pre-drill before fixing screws.

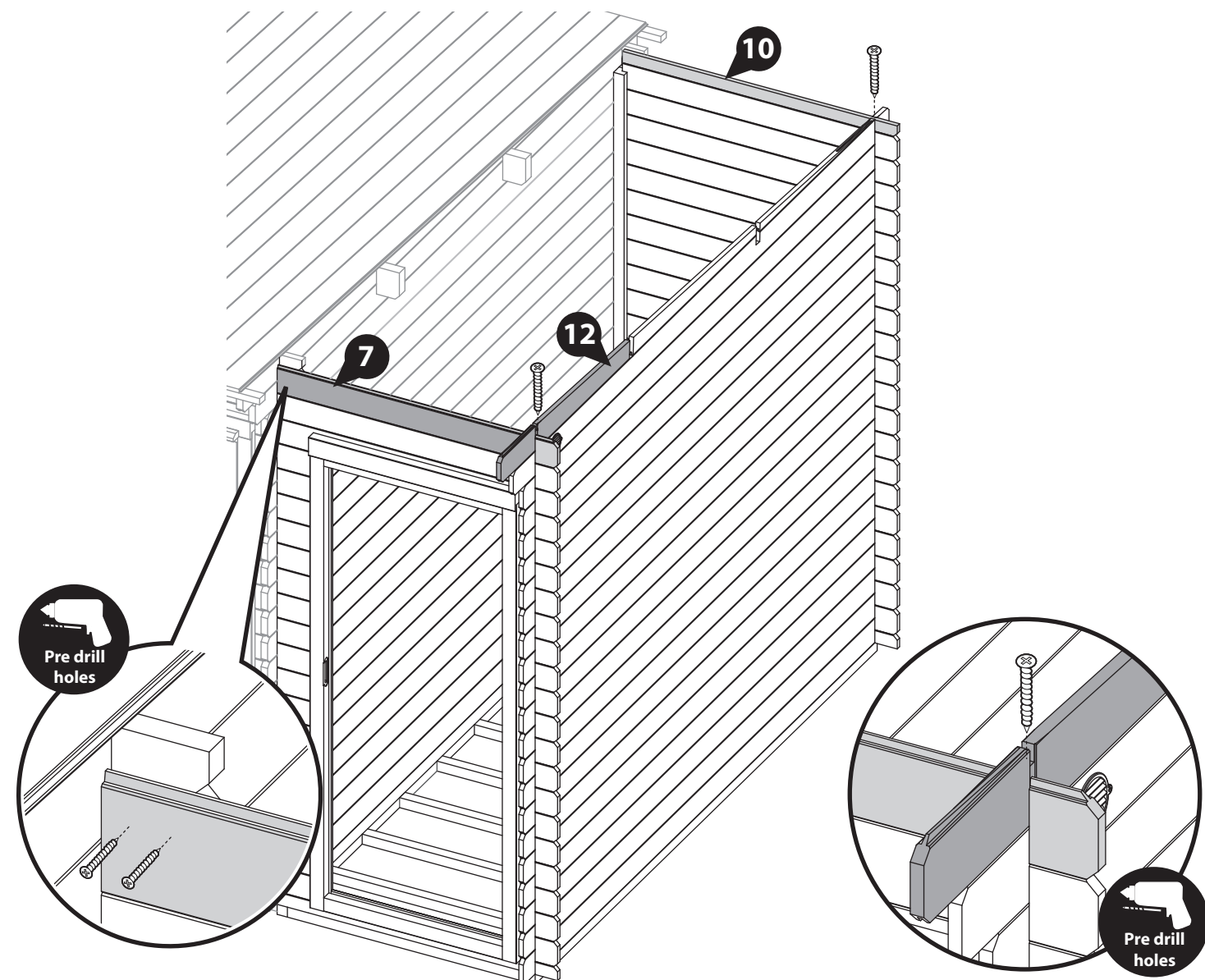

**Step 18**  
Parts Needed - No. 9 QTY 1

Following the method shown in the illustration, lay the final finisher board (No.9) onto the shed.

*\*Ensure that the boards are level and flush with each other as you lay each one.*

Fix the Finisher Board (No.9) to the Gable below by screwing through the notch using 1x70mm screw, as shown.

1x70mm screws

**Important:** Pre-drill before fixing screws.

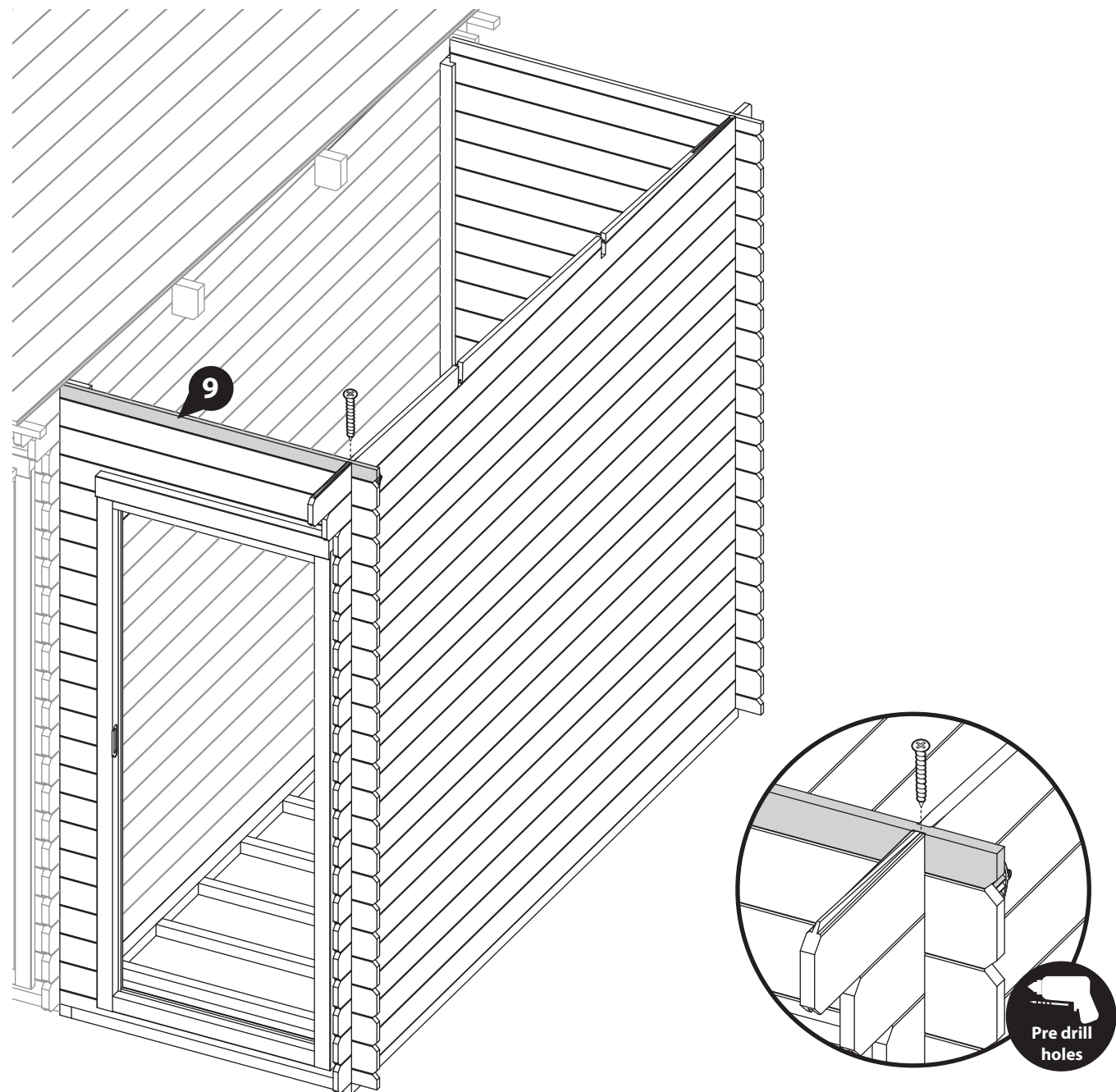
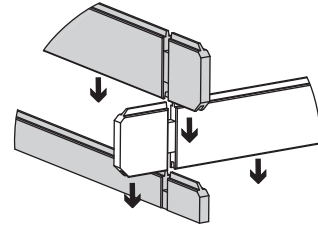

**Step 19**  
Parts Needed - No. 15 QTY 2

**a** Align the Roof Purlins (No. 15) into the cut out slots on the Gable, ensuring they interlock.

**Note:** Use a mallet and a scrap piece of wood to gently fix the purlins into position.

**b** Secure the roof purlins at each end by screwing through the purlins into the gable below, and through the purlin into the Log cabins purlin, as illustrated, using 2x70mm screws per end.

8x70mm screws

**Important:** Pre-drill before fixing screws.

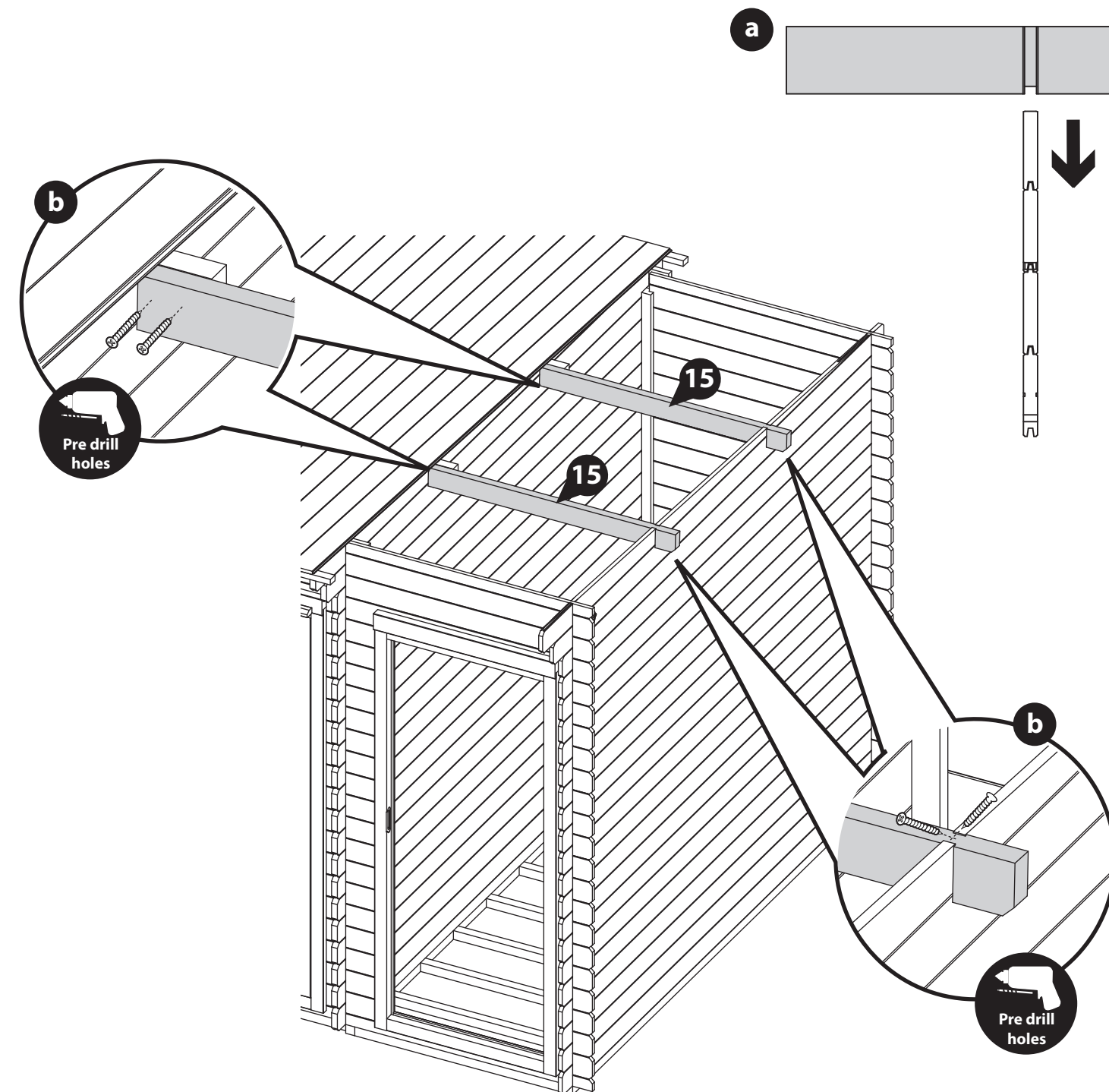



**Please Note:** The construction of your shed roof will differ depending on which log board thickness your cabin is made up of.

*If your log cabin is made up of 19mm boards, please follow the instruction step for 19mm cabin roof below.*

*If your log cabin is made up of 28mm, 34mm or 44mm boards, please follow the instruction step for 28mm, 34mm or 44mm cabin roof on the following page.*

**Step 20 - 19mm cabin roof.**

**Parts needed - No. 16 QTY 11**

**No. 25 QTY 5**

**a** Place the remaining roof board from the Log Cabin onto the roof. Fix in place to the Purlin, front and back of the cabin, using 4x40mm screws.

**b** Place the first roof board (**No. 16**) onto the shed add on, making sure the board interlocks with the last placed board from the cabin, and is flush and level.

Ensure there is an even amount of overhang between the log boards and roof board at the front and back of the cabin. Once in position, fix to the purlins, front and back of the shed add on using 4x40mm screws.

To ensure the roof boards are not laid too close together, use the spacers (**No. 25**) provided to create a 2mm gap. Adjusting the spacing between the boards allows the wood to swell in damp weather.

Continue to add roof boards onto the roof. Once in position fix to the purlin, front and back of the log cabin using 4x40mm screws per roof board.

*You have been issued with 11 roof boards, but you may only need to use 10.*

**c** The last board will overhang past the end of the Purlins. Using a straight edge and a pencil, mark out a line as a guide.

Saw along the pencil mark and remove the excess. Place the cut down board's back onto the roof and secure into place using 4x40mm screws per board.

**\*Please note:** The Log cabin used in the step is for illustrative purposes only and may differ from your choice in building, however the process of fitting the roof boards is the same.

**44x40mm screws**

**Important:** Pre-drill before fixing screws.

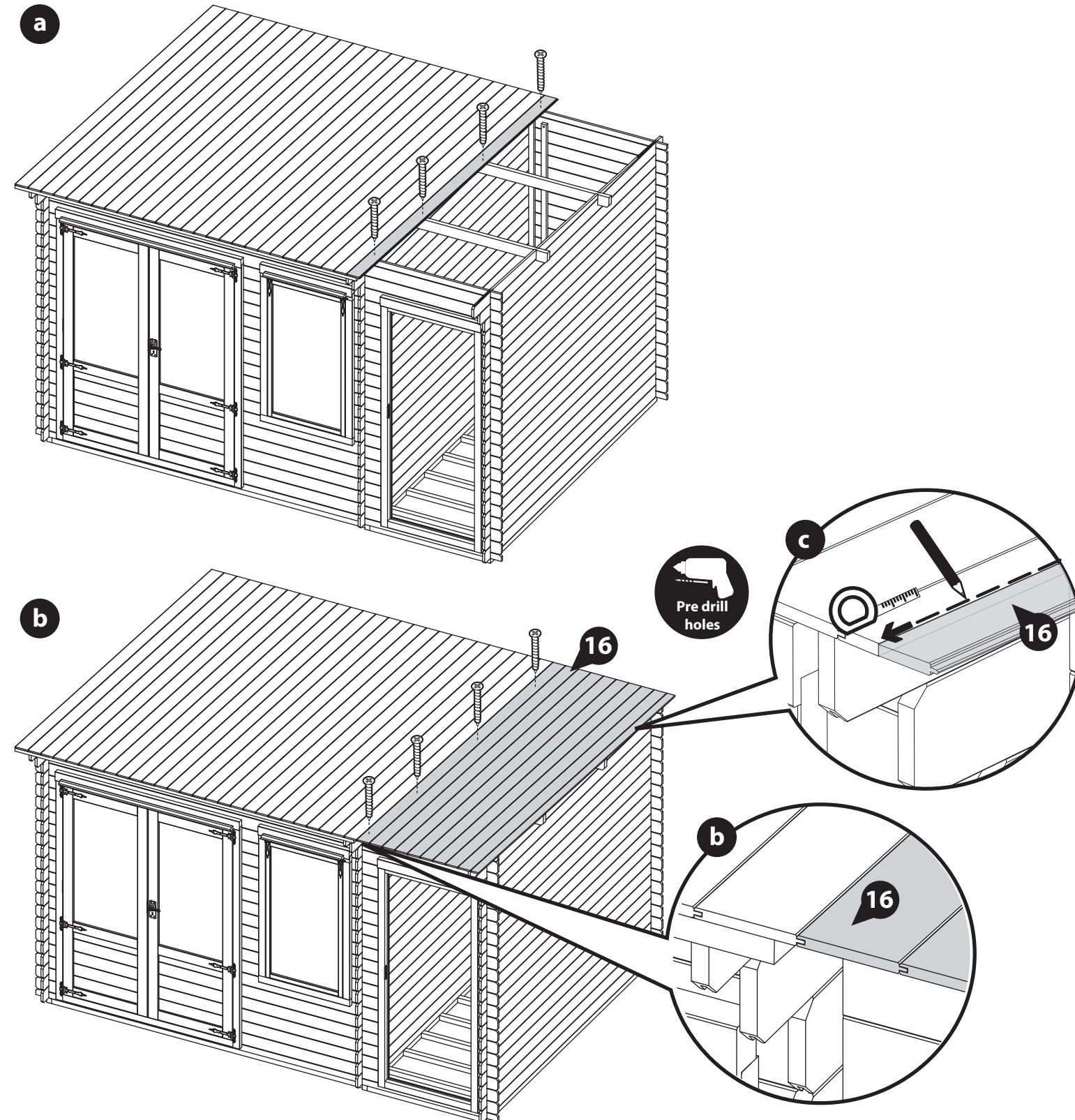

**Step 20 -28mm, 34mm or 44mm cabin roof.**

**Parts needed - No. 16 QTY 11**  
**No. 25 QTY 5**

**a** Place the remaining roof board from the Log Cabin onto the roof.

This board will overhang past the end of the cabins purlins. Using a straight edge and a pencil, mark out a line as a guide.

Saw along the pencil mark and remove the excess. Place the cut down board's back onto the roof and secure into place using 4x40mm screws per board.

**b** Place the first roof board (**No. 16**) onto the shed add on, making sure the groove is flush to the previously cut board on the log cabin. Ensure the boards are flush and level with those on the cabin.

Ensure there is an even amount of overhang between the log boards and roof board at the front and back of the cabin. Once in position fix to the purlins, front and back of the shed add on using 4x40mm screws.

To ensure the roof boards are not laid too close together, use the spacers (**No. 25**) provided to create a 2mm gap. Adjusting the spacing between the boards allows the wood to swell in damp weather.

Continue to add roof boards onto the roof. Once in position fix to the purlin, front and back of the log cabin using 4x40mm screws per roof board.

*You have been issued with 11 roof boards, but you may only need to use 10.*

**c** The last board will overhang past the end of the Purlins. Using a straight edge and a pencil, mark out a line as a guide.

Saw along the pencil mark and remove the excess. Place the cut down board's back onto the roof and secure into place using 4x40mm screws per board.

**\*Please note:** The Log cabin used in the step is for illustrative purposes only and may differ from your choice in building, however the process of fitting the roof boards is the same.

**44x40mm screws**  
**Important:** Pre-drill before fixing screws.

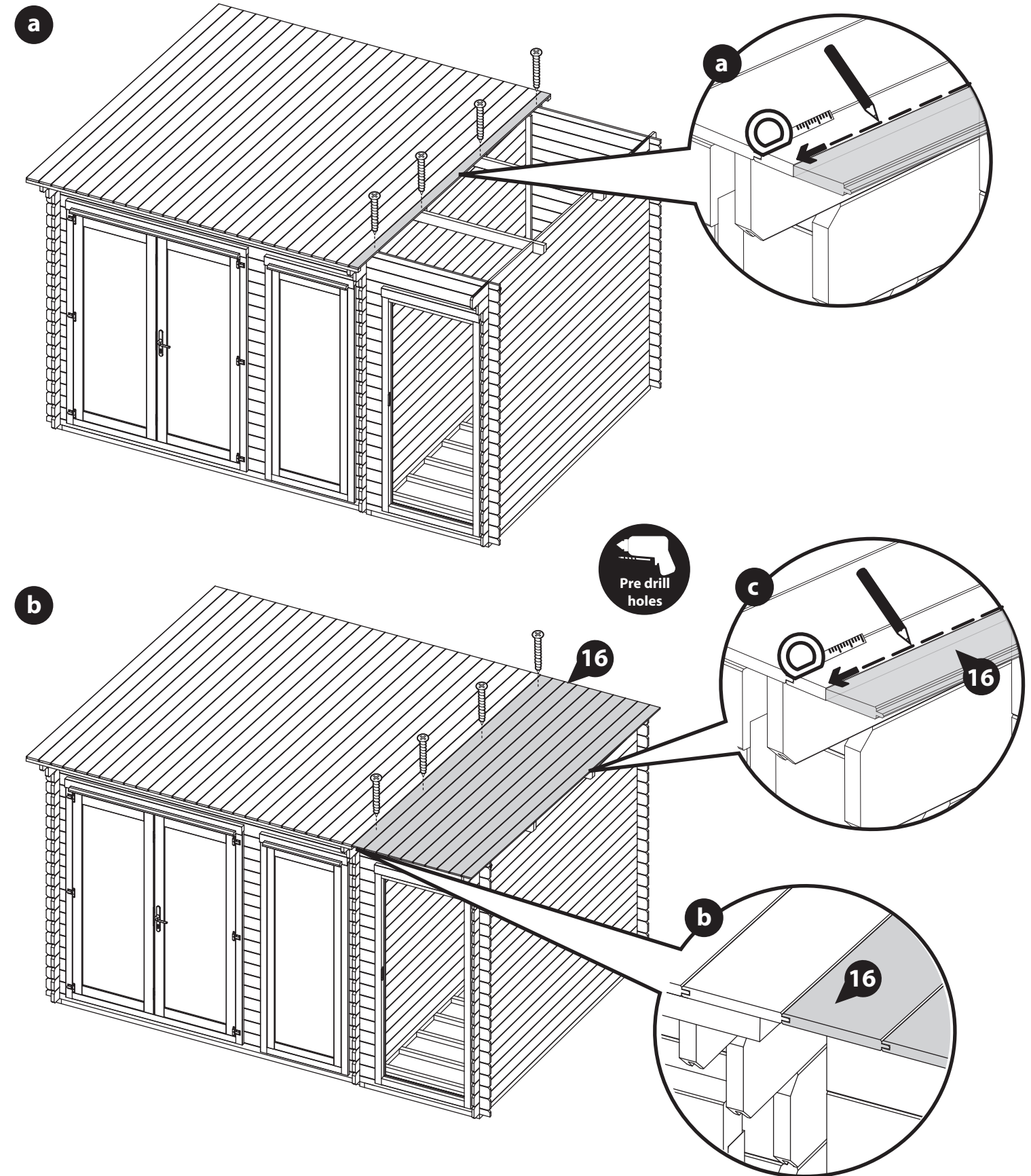



### Step 21

Parts Needed - No. 18 QTY 2

Ensuring the roof boards are flush and level, locate the Eaves Frames (No. 18) to the underside of the roof boards at the front and back of the shed. Secure in place using 4x30mm screws per frame, as shown in the illustration.

8x30mm screws

Important: Pre-drill before fixing screws.

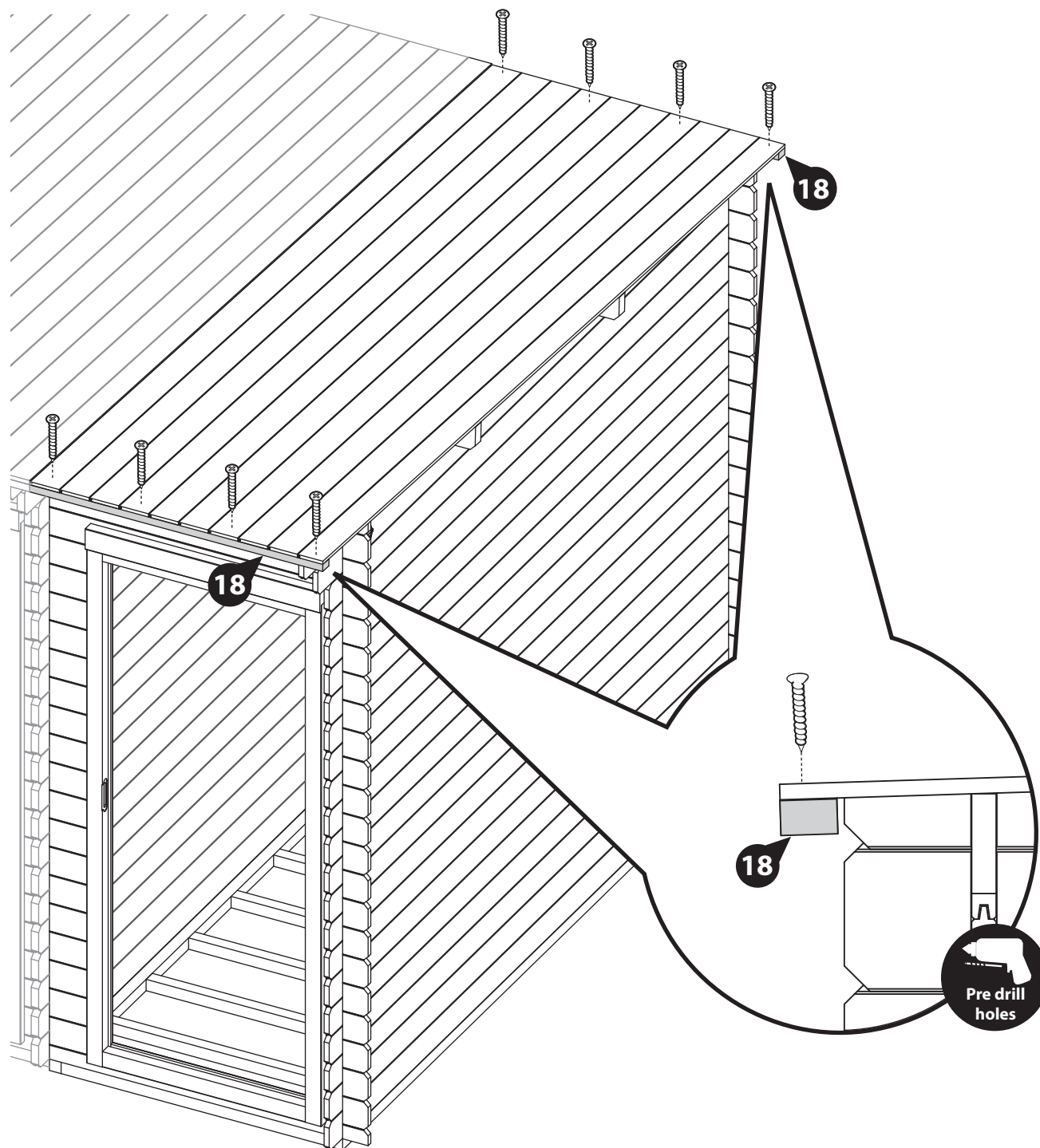
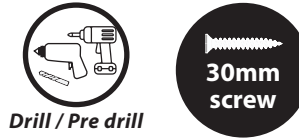

### Step 22

Parts Needed - No. 30 QTY 1  
No. 36 QTY 3

- a Place the door (No. 30) onto a flat surface and fix the three T-hinges (No.36) to the door using 5x30mm black screws per hinge.
- b Locate the door into the door frame on the shed, ensuring there is equal spacing on each side between the door and door frame.

Secure into position by screwing through the T-hinges (No.36) using 4x30mm black screws per hinge, making sure the doors open & close freely without restriction

*\*Ensure to screw into the framing and not into the channel.*

27x30mm black screws

Important: Pre-drill before fixing screws.

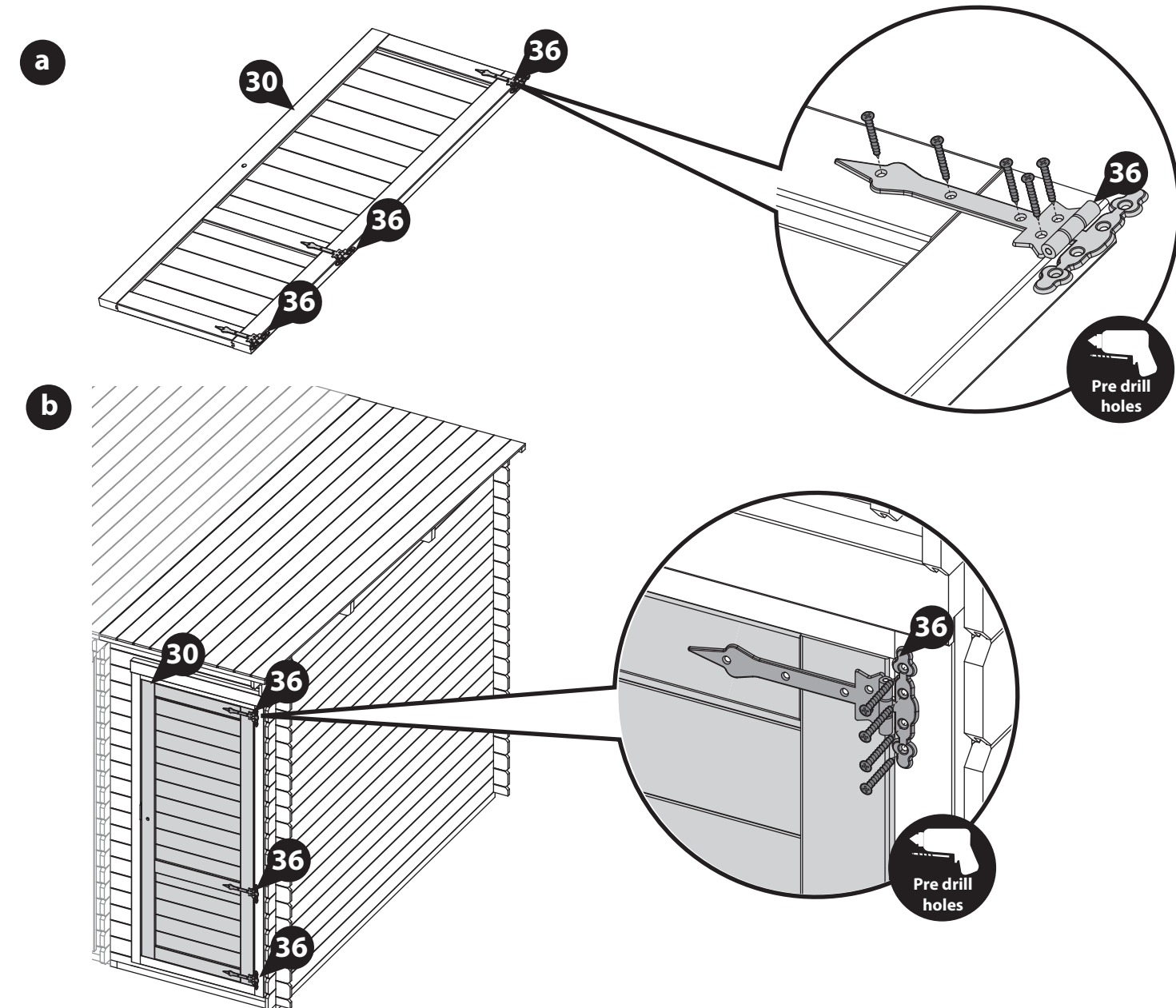
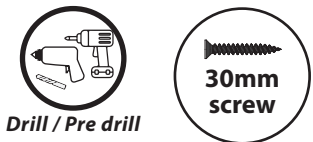



### Step 23

Parts Needed - No. 37 QTY 1

No. 38 QTY 1

No. 39 QTY 1

- a** With the Door open, locate the Dead lock (**No. 38**) into the recess in the Door (**No. 30**) and secure using the 2x30mm screws provided. Locate the the Key Plate (**No. 37**) onto the door framing and secure in place using 2x30mm screws.
- b** Locate the door handle (**No. 39**) to the front of the door and secure in place using 4x30mm black screws, as shown in the illustration.

4x30mm black screws  
4x30mm screws

**Important:** Pre-drill before fixing screws.

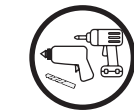

Drill / Pre drill



30mm screw



30mm screw

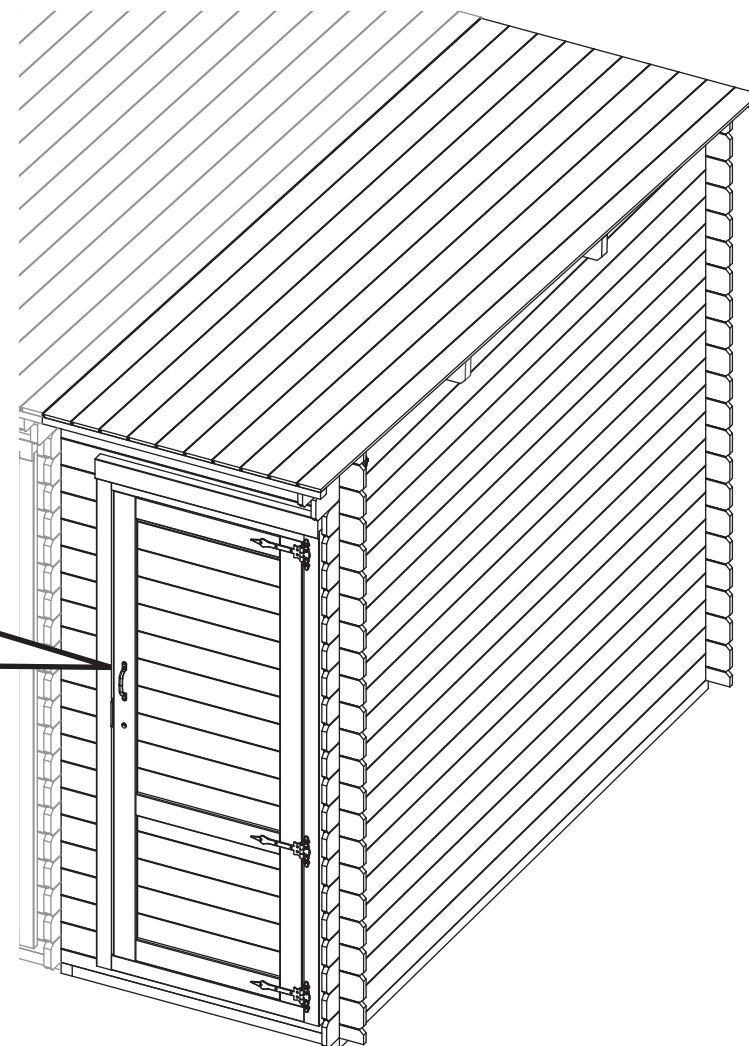

### Step 24

Parts Needed - No. 17 QTY 11

- a** Place the first floor board (**No. 17**) inside the shed add on, flush to the log board of the log cabins wall.

The floor board will need to be notched around the 'U' channel and the front log board from the log cabin. Measure around the protruding 'U' channel and log board and mark onto the floor board.

Once marked, saw into the floor boards to create the notch and place the board back into position.

- b** Continue adding the floor boards (*internally*) making sure to interlock each individual board.

*You have been issued with 11 floor boards, but in reality you may only need to use 10.*

**\*Do NOT secure the boards until the last board has been measured and cut.**

- c** Once a full board can no longer fit, measure the gap between the bottom of the tongue (*on the last board placed*) and the log board. Ensure to measure at multiple points along the board for added accuracy.

Using a straight edge, mark out the measurement onto the last floor board (**No. 17**), saw along the length and remove the excess. *Mark the final board 2mm under the measurement; This will allow the timber to expand and contract correctly.*

Once all the floor boards are in position, secure each board in place using 8x40mm screws per board. Ensure to screw through each of the floor boards into the floor bearers below.

88x40mm screws

**Important:** Pre-drill before fixing screws.



Saw



Drill / Pre drill



40mm screw

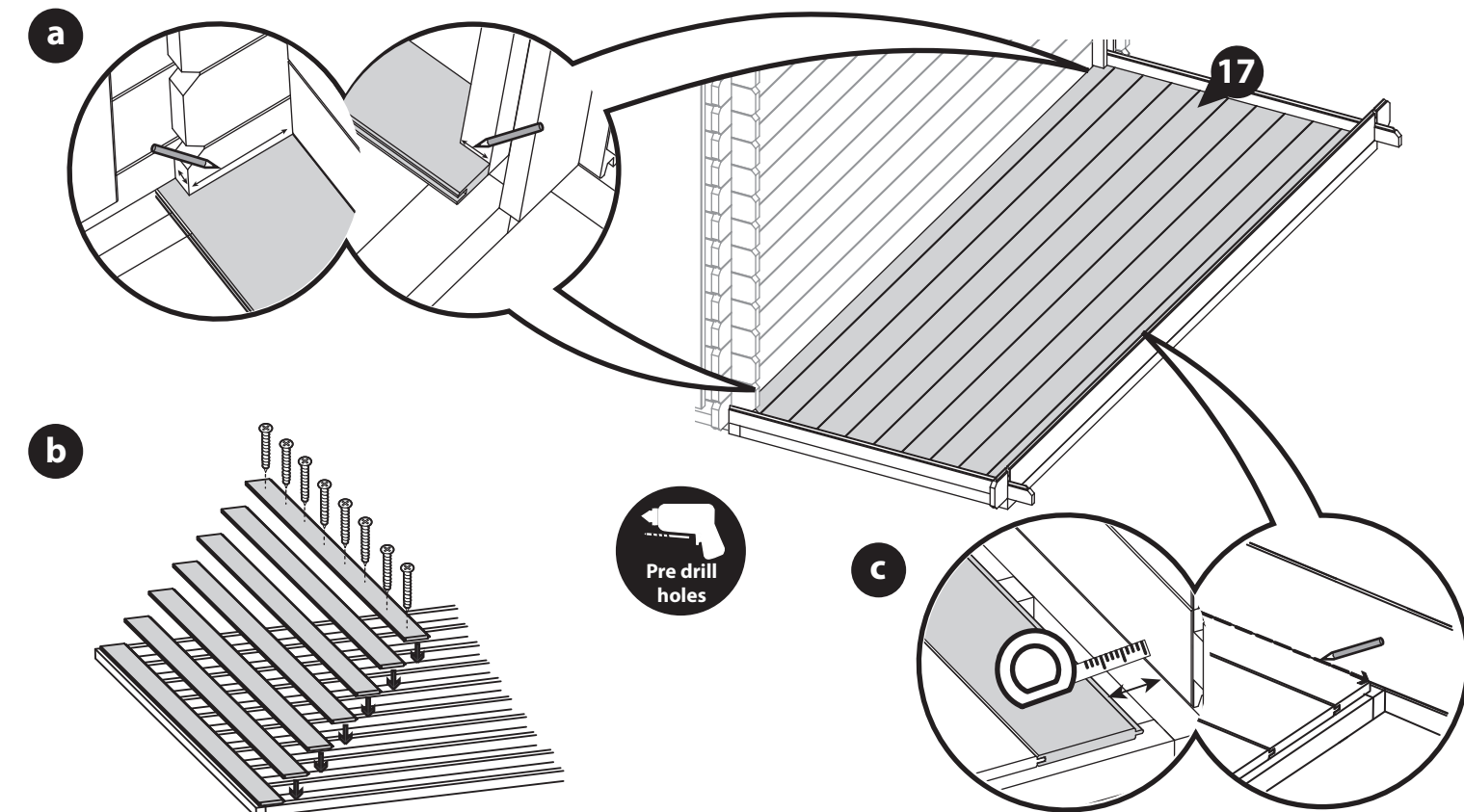

**Step 25**

**Parts needed - No. 20 QTY 2**

Inside the building place the closure trim (**No. 20**) against the boarding and align with the roof as shown in the illustration.

**\*Measure and cut the closure trims to fit the internal space.**

Once in position fix each trim into place by pre drilling a pilot hole and using 6x30mm screws per trim, equally spacing them along the face of the board.

**12x30mm screws**  
**Important:** Pre-drill before fixing screws.

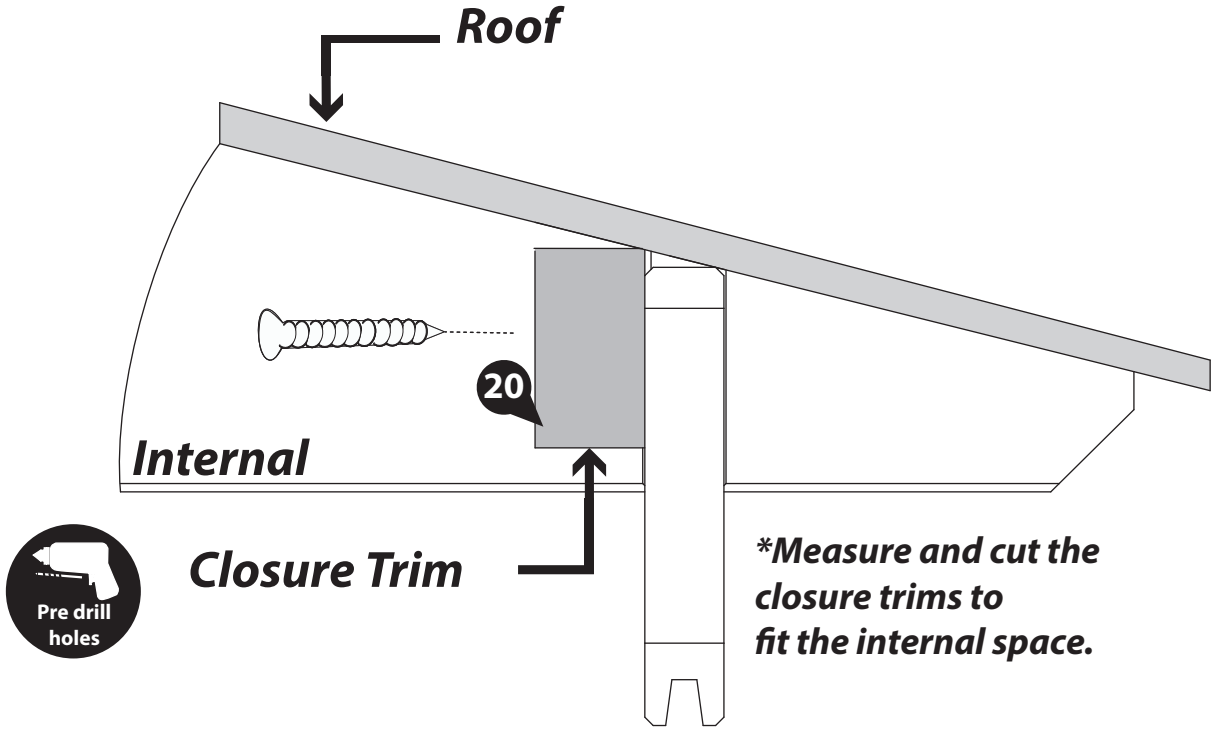

**\*Measure and cut the closure trims to fit the internal space.**

**Step 26**

**Parts needed - No. 20 QTY 1**

Once the floor has been laid arrange the closure trim (**No. 20**) around the outside edge of floor (**internally**), measure and cut down accordingly to best match the internal space.

Secure each trim section into place using 6x30mm spaced equally along the board as shown in the illustration.

**\*Do NOT fix the closure trim to the floor boards.**

**6x30mm screws**  
**Important:** Pre-drill before fixing screws.

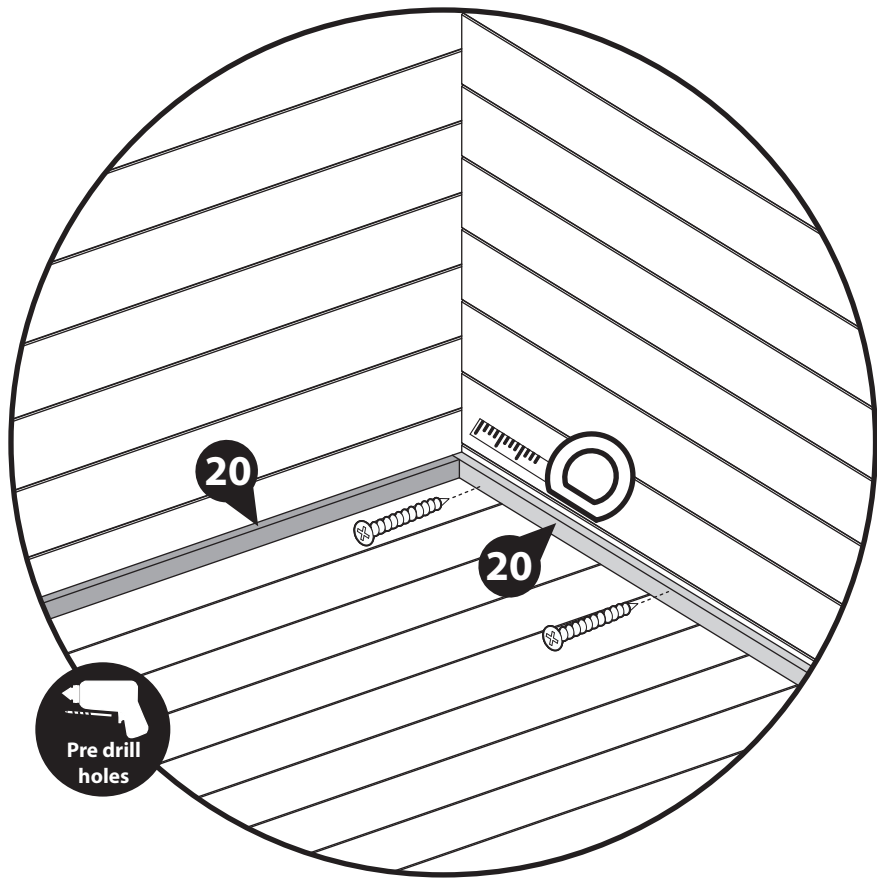

**Step 27**

**Parts Needed - No. 26**  
**No. 27**  
**No. 29 QTY 1**

*\*If you have purchased upgraded Felt, skip to Step 28. The base layer is not required.*

**a** Cut the Sand Capping Felt (**No.26**) into one sheet measuring:  
**3x3 Cabin + side shed = 4250mm (L) x 300mm (W)**  
**4x3 Cabin + side shed = 5250mm (L) x 300mm (W)**

Cut the Sand Felt (**No.27**) into four sheets measuring:  
**3x3 Cabin + side shed = 4250mm (L) x 1000mm (W)**  
**4x3 Cabin + side shed = 5250mm (L) x 1000mm (W)**

Lay the sheets onto the roof in the order shown, starting with the Capping Felt (**No.26**) as the first sheet laid, then the remaining four sheets (**No.27**), as shown.

Ensure the sheets overhang each side by 50mm and overlap each other by 100mm.

*There may be a larger overhang around the building than suggested, if so, excess felt can be cut off from around the building after fitting is complete.*

**b** To ensure a complete bond between the sheets, apply the Butyl (**No.29**) between each overlapping layer, as shown in the image. Ensure to apply the Butyl using a sealant application gun and in a 'wiggly' line for the best finish. Once applied, compact the layers to seal.

At each corner, fold the felt over each other so they sit on the front and backs of the building, as shown.

Secure the felt in place by hammering felt tacks into the overlapping layers, the front, back and sides of the building at 100mm intervals, as shown.

*\*Please note: The Log cabin used in the step is for illustrative purposes only and may differ from your choice in building, however the process of fitting the felt is the same.*



**250 x Felt Tacks**

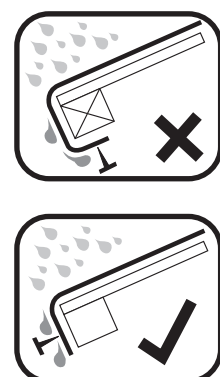
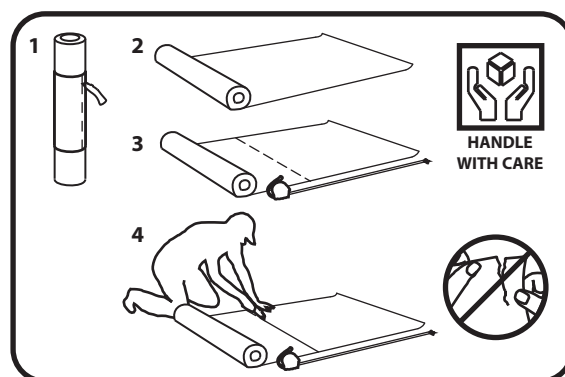
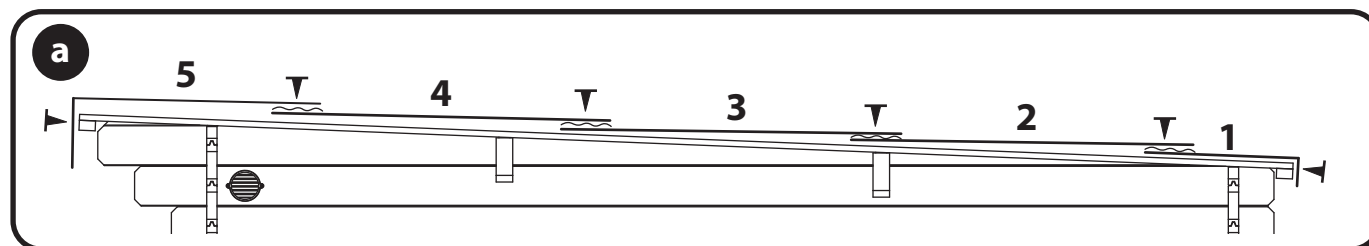

**a** 3x3 Cabin + side shed

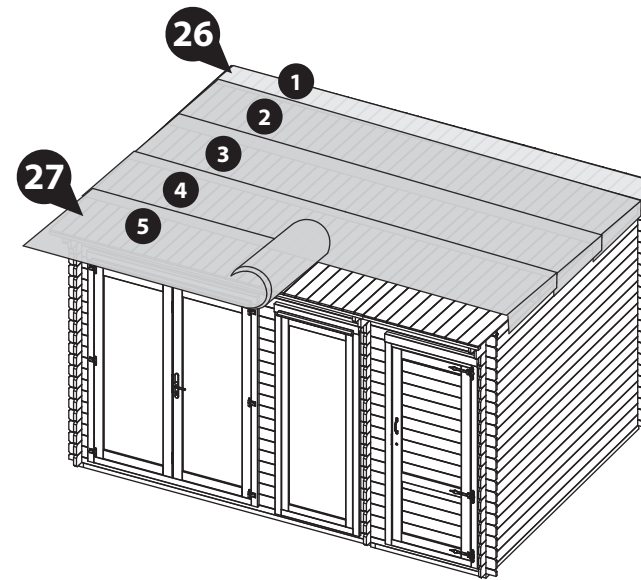

4x3 Cabin + side shed

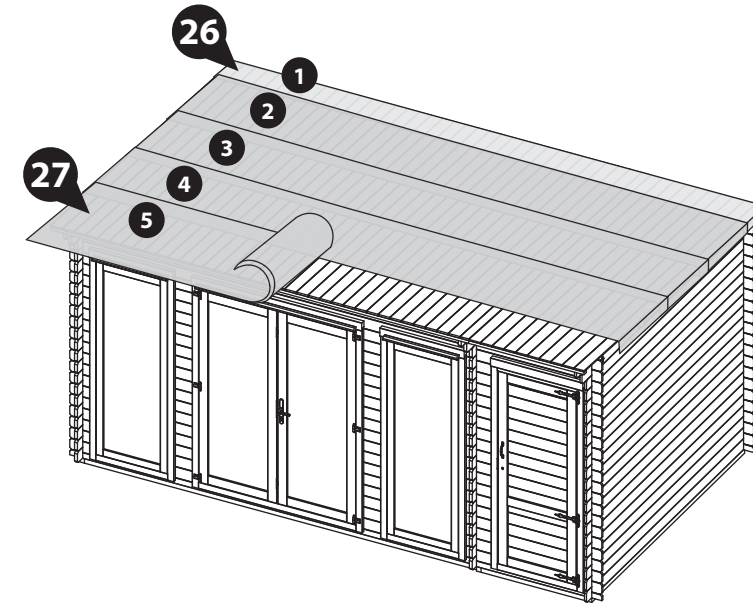

**b**

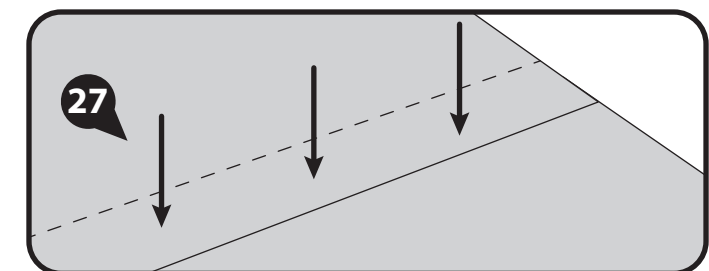
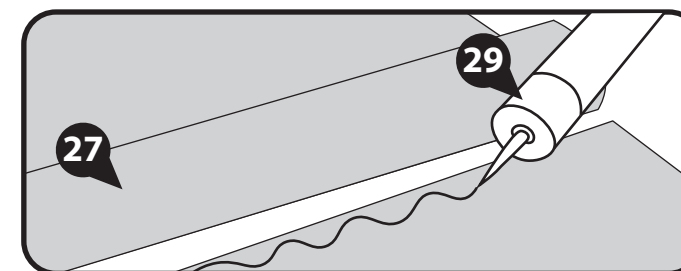
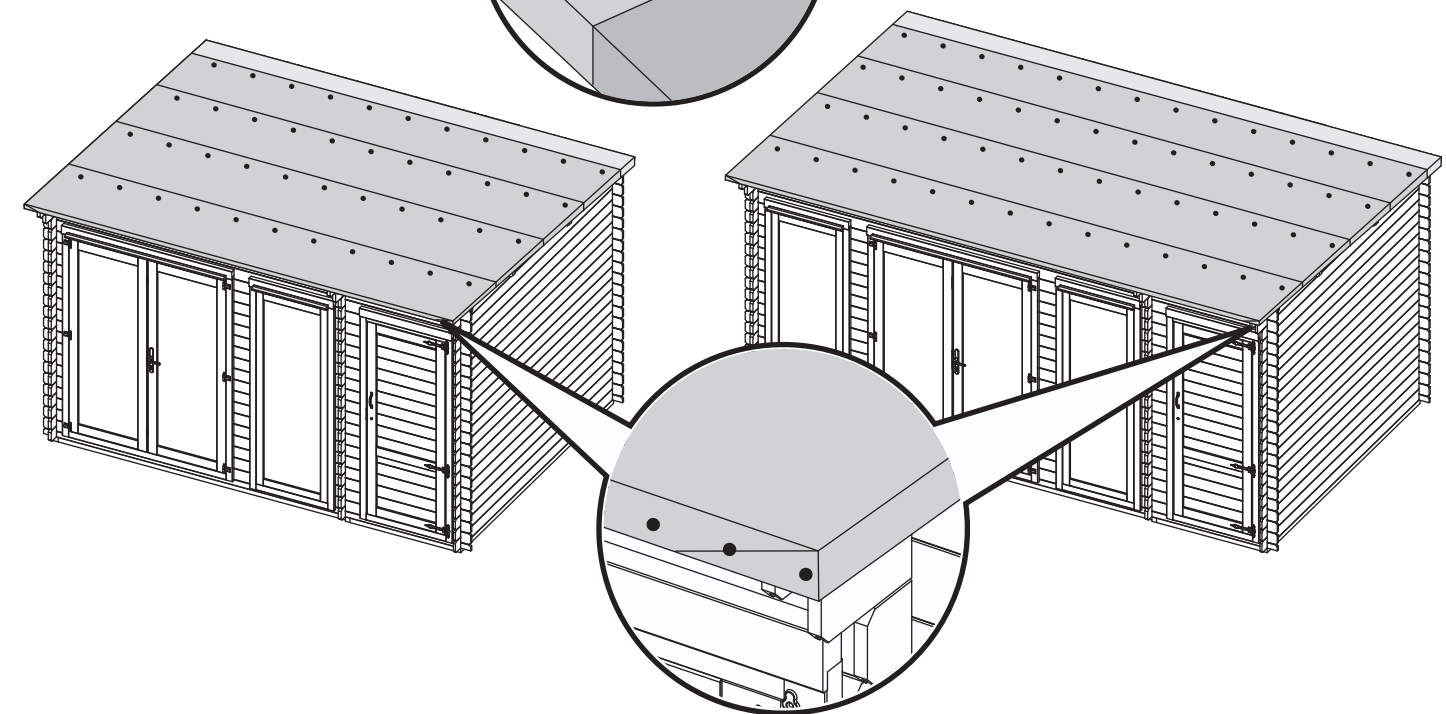
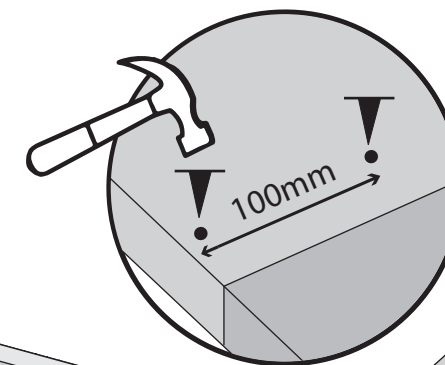



**Step 28**

**Parts Needed - No. 28**

**No. 29 QTY 1**

*\*If you have purchased upgraded Felt, follow this step using the Felt provided.*

- a** Cut the Green Felt (**No.28**) into four sheets measuring:  
**3x3 Cabin + side shed = 4250mm (L) x 1000mm (W)**  
**4x3 Cabin + side shed = 5250mm (L) x 1000mm (W)**

Lay the sheets onto the roof in the order shown. Ensure the sheets overhang each side by 50mm and overlap each other by 100mm.

**\*\*Make sure that where the Green felt layers overlap is offset to the previously laid Sand felt, as shown in the diagram. This will ensure the felt can be secured correctly and allows water to drain off efficiently.\*\***

*There may be a larger overhang around the building than suggested, if so, excess felt can be cut off from around the building after fitting is complete.*

- b** To ensure a complete bond between the sheets, apply the Butyl (**No.29**) between each overlapping layer, as shown in the image. Ensure to apply the Butyl using a sealant application gun and in a 'wiggly' line for the best finish. Once applied, compact the layers to seal.

At each corner, fold the felt over each other so they sit on the sides of the building, as shown. Ensure these corners sit on the opposite sides to the sand felt, as suggested.

Secure the felt in place by hammering felt tacks into the overlapping layers, the front, back and sides of the building at 100mm intervals, as shown. Ensure to stagger the tacks on the sides, front and back to avoid colliding with the layers below.

**\*Please note:** The Log cabin used in the step is for illustrative purposes only and may differ from your choice in building, however the process of fitting the felt is the same.

**200 x Felt Tacks**

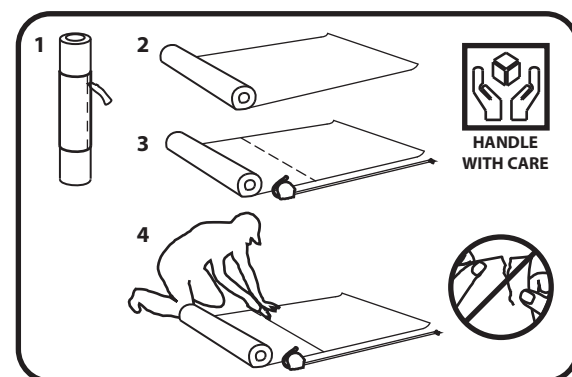
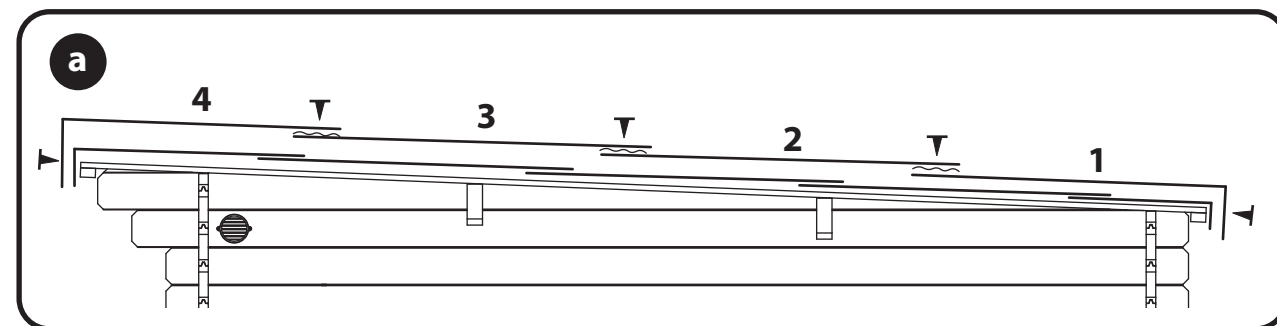

**a** 3x3 Cabin + side shed

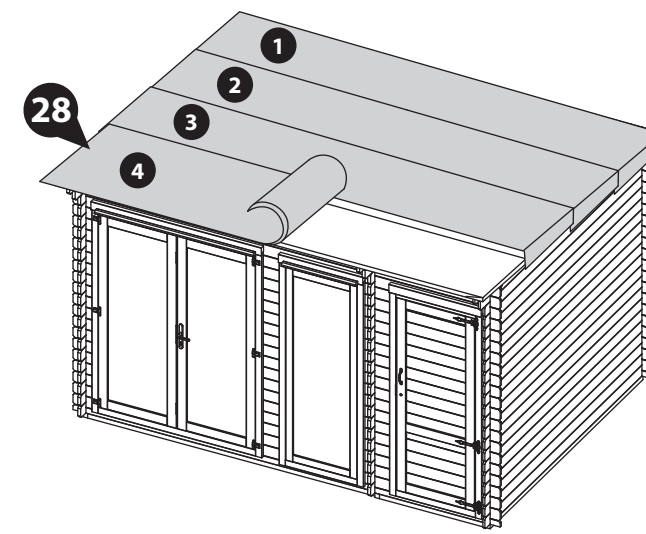

4x3 Cabin + side shed

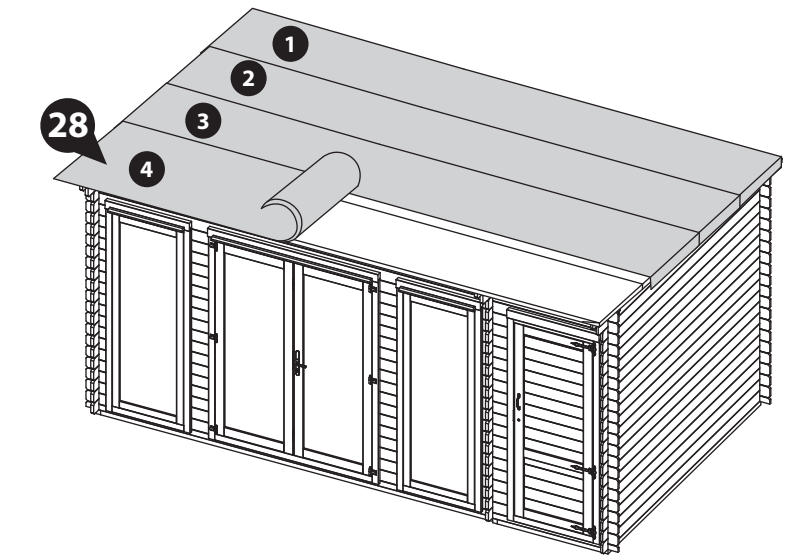

**b**

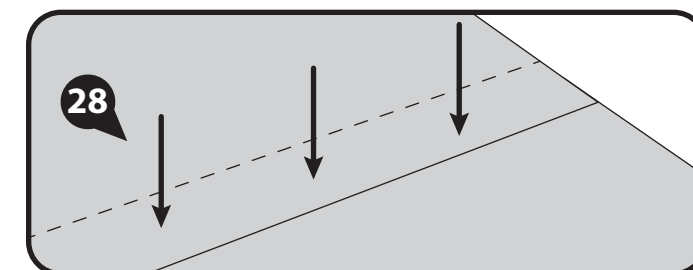
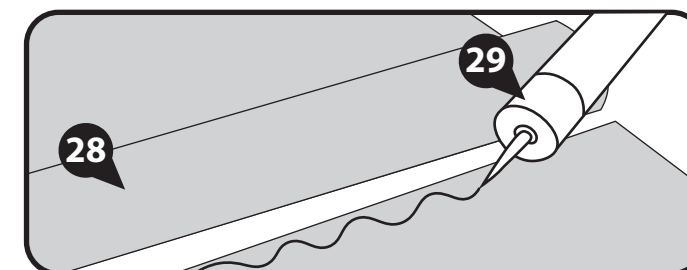
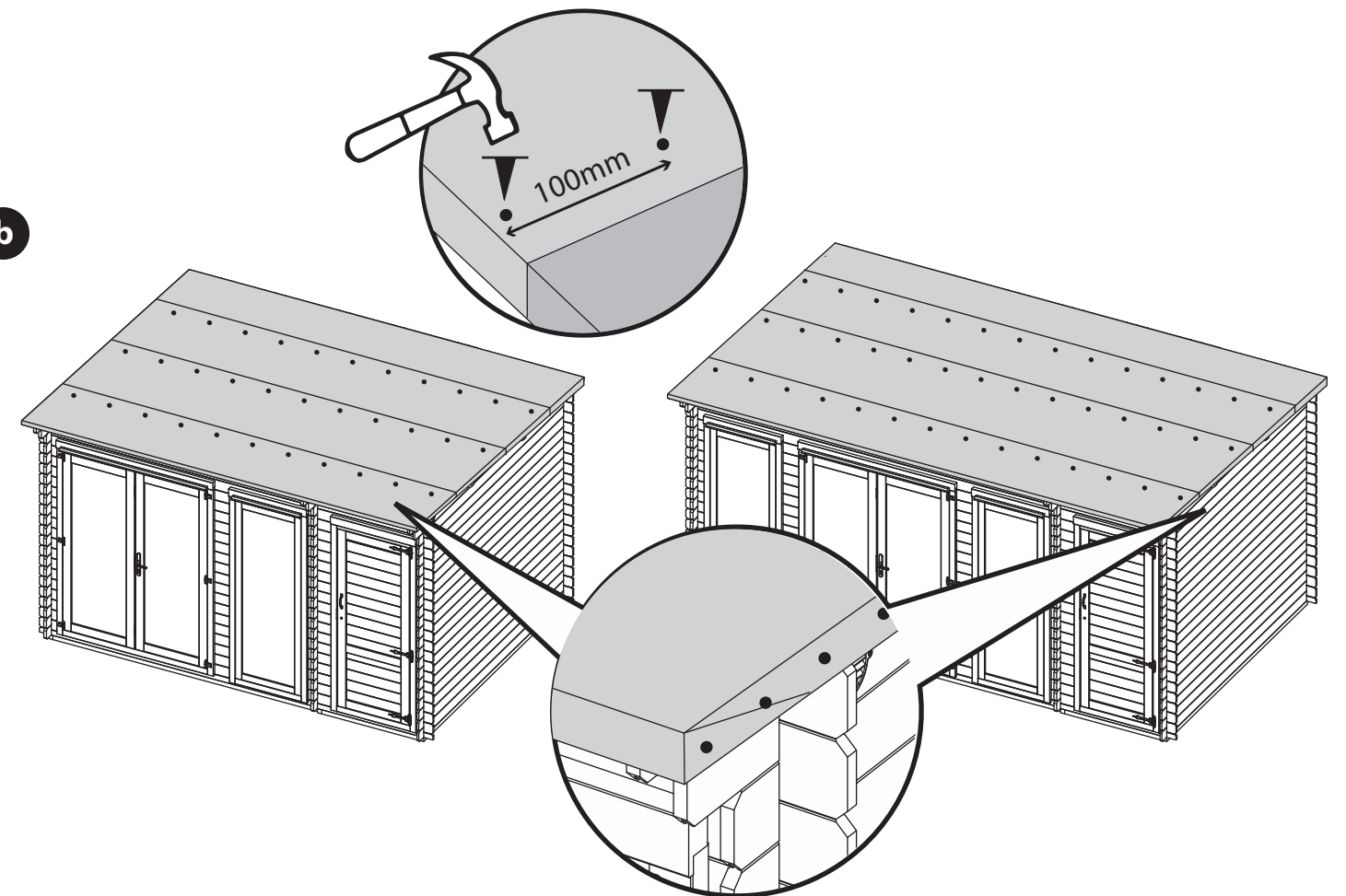

**Step 29**  
Parts Needed - No. 19 QTY 2

**a** Attach the Shed Fascias (**No. 19**) and the remaining Cabin Fascias to the front and back of the log cabin and Shed (*ensuring to trap the felt in-between the fascia's*) securing in place by screwing through the Fascia into the Eaves Frames using 3x40mm screws per Fascia for the shed area and 4x40mm screws per Fascia for the cabin area.

Once in place, mark the excess Fascia with a pencil and trim the Fascias to follow the shape of the building, as shown in the illustration.

**b** Locate the remaining Cabin Fascias to the sides of the log cabin and Shed (*ensuring to trap the felt in-between the fascias*) and secure in place using 6x40mm screws per fascia, screwing through the Fascia into the Purlins, eaves frame or log board behind.

Once in place, repeat the above method to trim the fascias to follow the shape of the building.

**Ensure the fascias at the back of the log cabin sit level or lower than the felt to allow water to run off.**

**\*Please note:** The Log cabin used in the step is for illustrative purposes only and may differ from your choice in building, however the process of fitting the fascias is the same.

**6x40mm screws**  
**Important:** Pre-drill before fixing screws.

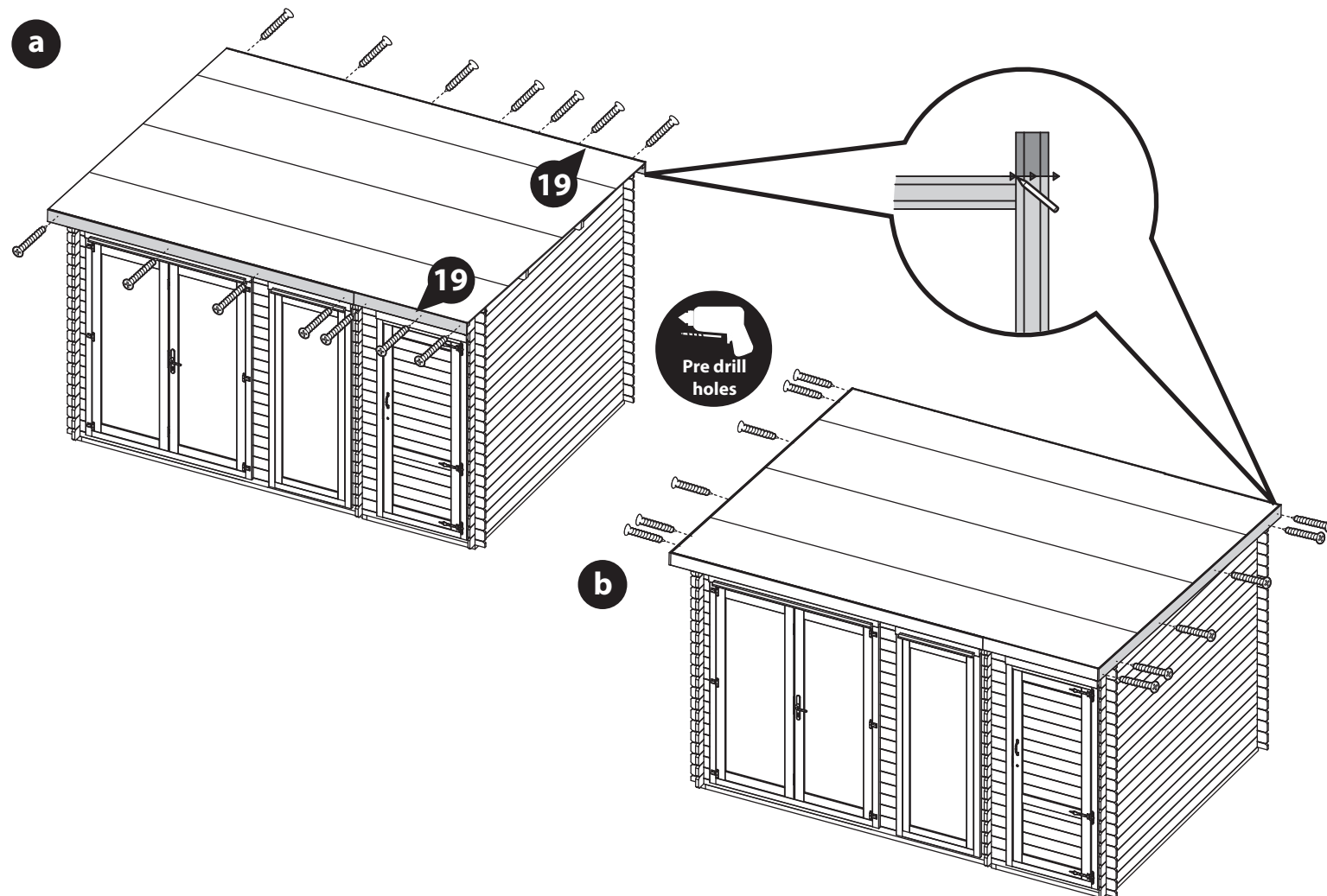

**Step 30**  
Parts needed - No. 21 QTY 6

Arrange the storm braces (**No.21**) around the building (*internally*), placing two storm braces per wall.

**\*Ensure the storm braces are secured at the highest point possible on each side.**

Fix in place using 2x60mm bolts per brace, making sure the washer & nut are tightened from the outside of the building.

The storm braces will need to be altered during the buildings life as the moisture content within the log boards changes. The boards will expand during periods of high moisture (Winter) and shrink during periods of low moisture (Summer).

**\*\*Storm braces are required to be adjusted during changes in humidity to allow the building to expand and contract. To do this, periodically loosen the bolts, adjust the storm brace position and re-tighten.**

**\*\*\*Important: Ensure each bolt is tightened using a washer so as not to damage the log boards.**

**\*Please note:** The Log cabin used in the step is for illustrative purposes only and may differ from your choice in building, however the process of fitting the Storm Braces is the same.

**12x60mm bolt sets**  
**Important:** Pre-drill before fixing screws.

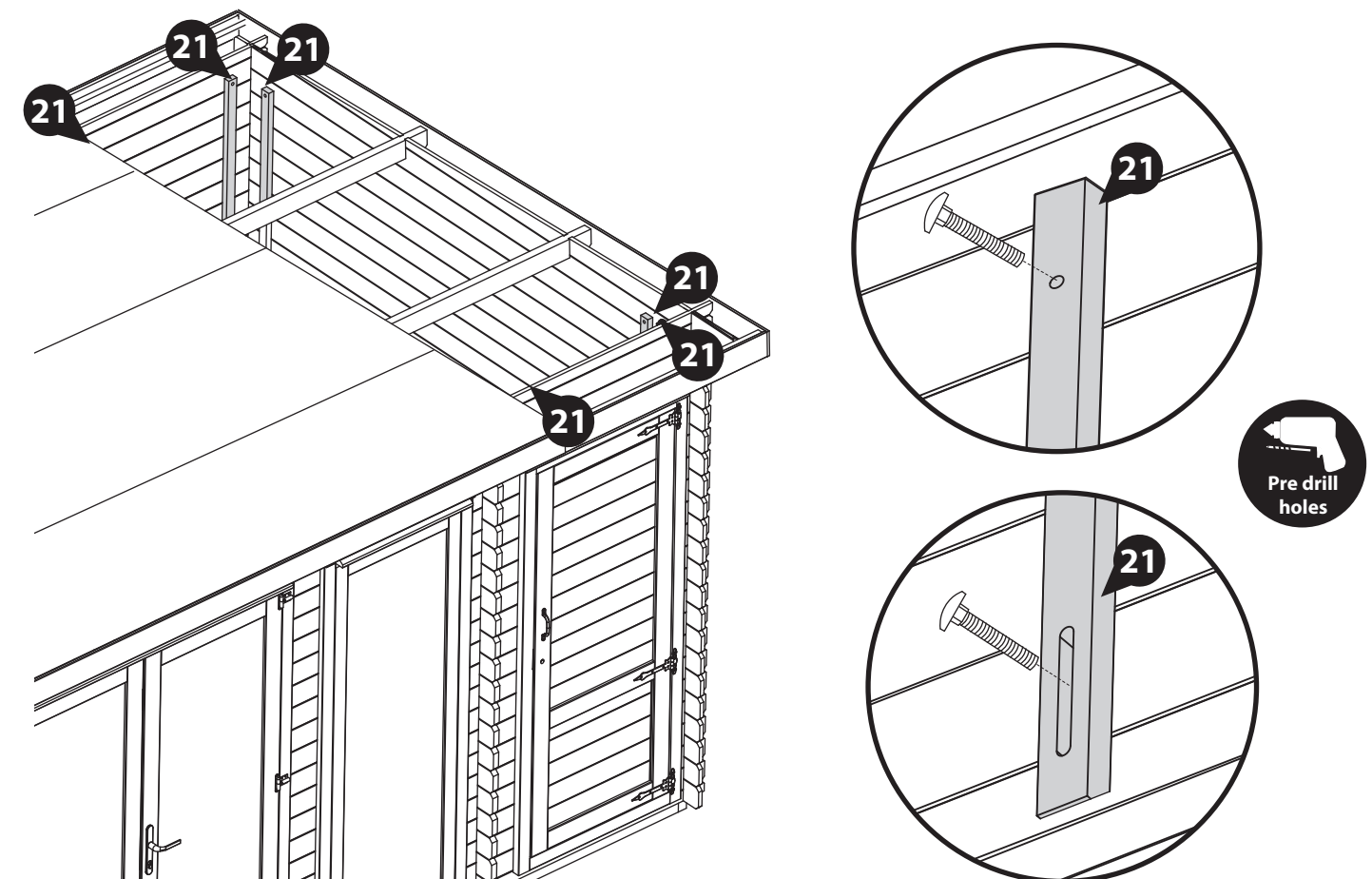
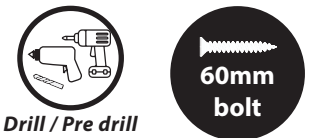



### Step 31

#### Parts Needed - No. 35 QTY 1

Attach the Rain Guards (No. 35) to the Window frame, fixing in place onto the framing above the window using 3x70mm screws per rain guard.

**\*Please note:** The Log cabin used in the step is for illustrative purposes only and may differ from your choice in building, however the process of fitting the Rain Guard is the same.

#### 3x70mm screws

**Important:** Pre-drill before fixing screws.



Drill / Pre drill



70mm screw

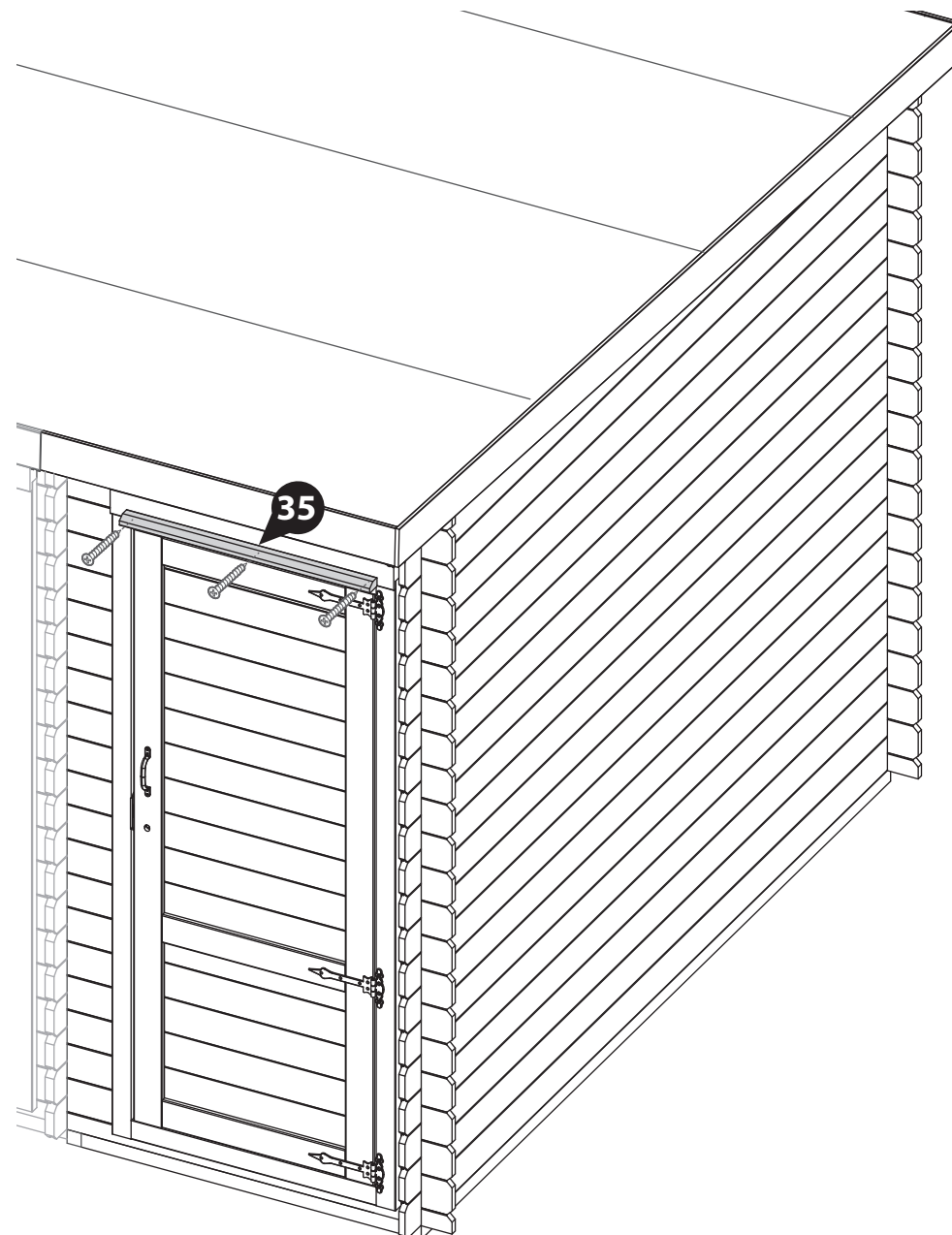

### Step 32

Once constructed, apply a preserving treatment and a waterproofing treatment to your garden building as soon as possible. This will help to protect your building and prevent decay.

See page 26 for a full guide and instructions.

**\*Please Note:** This image is for illustrative purposes and may differ from your window and door position. Nevertheless, the process of treating your building, removing the protective covers and sealing the windows is the same.



Treatment



Mixing stick



Paintbrush/sprayer/  
roller



Apply treatment.

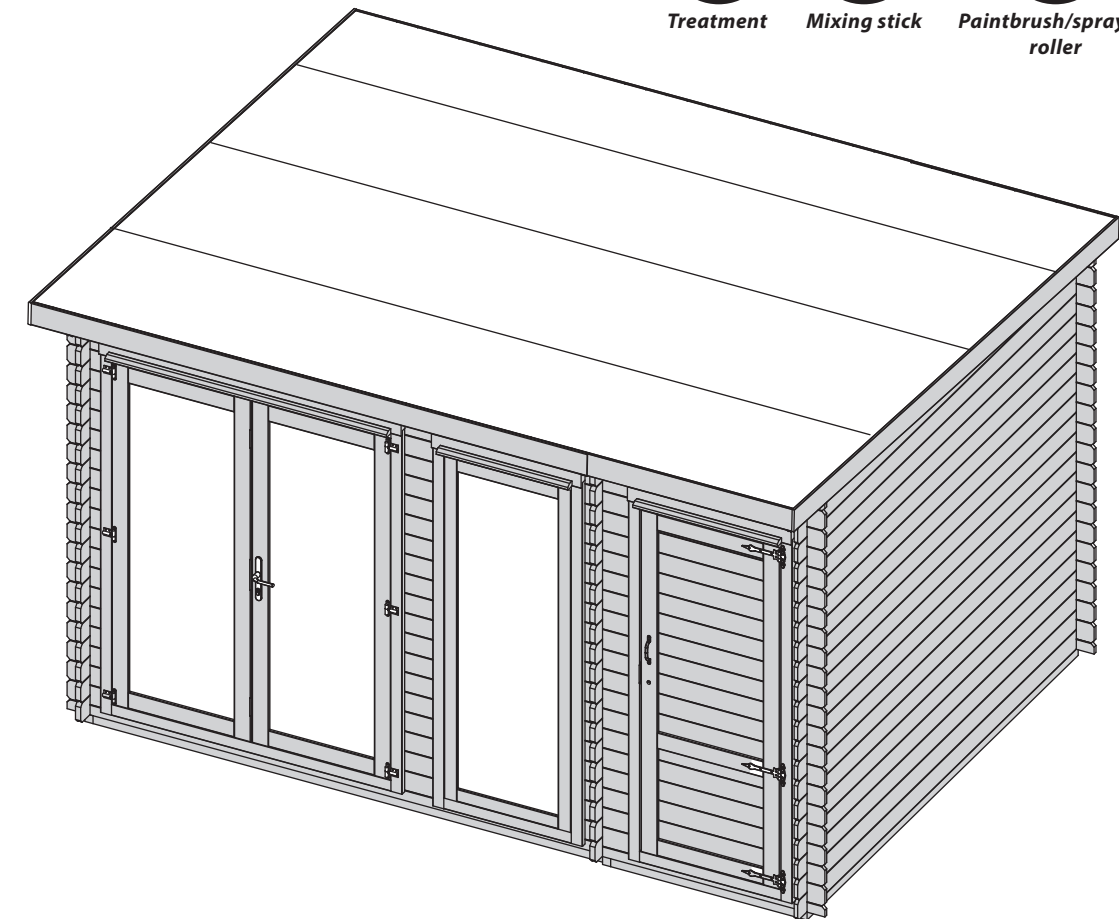

## LEAVE US A REVIEW...

Want to share your experience with us?  
Leave us a review on Feefo, TrustPilot or Google.

Your reviews help other people find and trust our business, as well as helping to play an important role in our growth and improvement!

## TREATING YOUR GARDEN BUILDING

Preservation of wood that's outdoors is vital. A little early care will help protect your garden building, improve its appearance and ensure maximum longevity. Insects, moisture, salt, and changing weather can have dramatic effects on the stability and appearance of your garden building. Once your building is installed, you've checked it over and you're happy with it, you can take a few basic precautions to prepare it for the elements. Treating your garden building helps prevent decay and, by repelling water, discourages the growth of moulds and fungi that could jeopardise the structural integrity of the wood.

**Dip Treated buildings** - Require a preservative treatment to protect against rot and decay and a waterproof treatment to prevent water ingress  
**Pressure Treated buildings** - Require a waterproof treatment to prevent water ingress  
**Log Cabins/Insulated Garden Rooms** - Are supplied untreated and require a preservative and waterproofing treatment.



**ANY QUESTIONS?**  
Scan the QR code to contact us via our customer portal.

To apply a preservative and water proofing treatment (pressure treated products do not require a preserver), follow the manufacturer's instructions but in principle, stick to the following steps:

- ✓ Weather permitting, ensure to treat your garden building within 14 days of installation.
- ✓ Wear latex or rubber gloves, eye protection and (if spraying) a mask.
- ✓ Prepare the wood, by sanding down any ridges or inconsistencies in the wood, smoothing out knots and end-cuts.
- ✓ Choose a dry day to treat your garden building. If you're spraying rather than brushing paint on, avoid a windy day.
- ✓ Be sure you can safely reach all the sections you need to paint - and if you need a ladder, make sure it's safely positioned before climbing. Lay dust sheets around to avoid paint splatters on your base or surrounding plants.

- ✓ Tape around windowpanes to avoid smears when you're painting the frames.
- ✓ Keep pets and small children out of the way. The last thing you want is to have fur on your garden building paint, or little painted footprints all over your garden and home.
- ✓ Fill any gaps in the building's body with caulk or wood filler to prevent water and draughts getting in. Silicone based caulk is flexible and will move with the timber when temperature and humidity change. Allow to dry completely before treating. A handy tip for finding gaps is to go into your garden building and look for light leaking through joins and frames. If light gets in, then so will water.
- ✓ Liberally apply at least two coats of the treatment products with a brush or spray, taking care to allow the first coat to completely dry before applying the second.
- ✓ Make sure the solution permeates the whole of the surface area, especially around natural cracks, end cuts and nail/screw holes.



APPLY WOOD TREATMENT  
**IMMEDIATELY**  
AFTER ASSEMBLY



## 1 Perimeter

Check around the perimeter of your product to ensure there are not trees or plants that are in contact with or overhanging the building. This can affect airflow and overhanging trees, or branches can damage the roof, it is advised to keep plants at a distance.

## 2 Repair

Inspect the interior and exterior of the product to look for splits, cracks, and holes. Although this is a natural occurrence it can be prevented. A wood filler can be used to close the splits, cracks, and holes.

## 3 Roof

Check your roof regularly for tears, splits, damaged wood and fallen debris. If you notice any of this immediate repair is critical.

## 4 Doors & Windows

Expansion and contraction can cause doors and windows to stick or become difficult to open. Small adjustments to the hinge position can be made to the doors and windows to allow free movement.

## 5 Oil

Hinges can seize up over time, apply lubricant to the hinges and locks annually.

## 6 Screws & Bolts

It is advised to check all screws and bolts and tighten any loose you might find. For log cabins specifically the storm braces will require loosening. During humidity and temperature changes (seasons) to allow expansion and contraction to prevent gaping, twisting, popping, and warping.

## 7 Wash

At least once a year, give the outside of you building a good wash, to remove cobwebs, leaves, or any other dirt that may accumulate on the exterior.

## 8 Airing

Airing your product regularly prevents the build up of condensation which can cause the timber to warp, bow, boards to pop, distortion, rot and mould. Condensation can build up over time or daily, it is caused by a rise and fall in temperature.

Excessive moisture levels within your building can cause water to collect on the roofs, walls and floors internally. Leaving doors and windows open regularly can help combat the natural moisture build up.

## 9 Storm Braces

The storm braces will need to be altered during the buildings life as the moisture content within the log boards changes, altering the braces will help your building expand and contract properly. The boards will expand during periods of high moisture (Winter) and shrink during periods of low moisture (Summer).

Ensure each bolt is tightened using a washer so as not to damage the log boards.

## 10 Clean & Tidy

It is good practice to clean the inside and outside of your product regularly. Clear out the contents, sweep the floor, remove dirt and cobwebs. Check for areas of damp and investigate the cause to remove and prevent future occurrences. Check the ground around your product for build up of debris such as leaves, remove and ensure there is clear ventilation underneath the floor.

### Additional Playhouse Maintenance:

It is recommended that the following checks and maintenance are carried out at the beginning of each season as well as at regular intervals during the usage season.

- Check all nuts /bolts/ screws for tightness and tighten when required.
- Check for movement / opening of wood giving rise to protrusion of nail heads and tips.
- Check hinges.
- Replace defective parts in accordance with the manufacturers instructions.
- Check any crossbeams, suspensions and anchors.
- If a swing is included; check the swing seat, chains and ropes.

**IF THESE CHECKS ARE NOT CARRIED OUT THE ACTIVITY TOY COULD BECOME A HAZARD**

All our garden buildings have been designed and manufactured with care and attention to be the perfect addition to your outdoor space. To ensure you do get the best out of your new garden building and to increase the longevity we advise that you follow the product instructions and our manufacturer's recommendations as detailed below. Thank you for choosing a Mercia Garden product!

## 1 Choosing the most suitable location for your garden building...

A minimum of 60cm should be left around the perimeter of your garden building to allow access for maintenance, annual treatment and to allow air flow around the building.

Where possible you should avoid placing your garden building underneath large trees to prevent the tree causing damage to the building.

## 2 Preparing the base for your garden building...

All our buildings must be built on a firm, level base to ensure the longevity of the building and prevent the wood from distorting. We recommend either concrete, concrete slabs or a wooden base, such as our 'Portabase'.

The base should be the same size as the building's floor bearer frame. These base dimensions are given on the first page of the contents. This will create a run off for water and preventing water from pooling underneath the building.

We also recommend that the floor of the garden building is a minimum of 25mm above the surrounding ground level to avoid flooding.

## 3 After installation...

Once your garden building has been installed, it will need to be treated within 14 days (weather permitting) and annually to prevent the timber from deteriorating and to waterproof it. This is required to maintain the anti-rot guarantee.

Dip Treated buildings - Require a preservative treatment to protect against rot and decay

and a waterproof treatment to prevent water ingress.

Pressure Treated buildings - Require a waterproof treatment to prevent water ingress.

Log Cabins/Insulated Garden Rooms - Are supplied untreated and require a preservative and waterproofing treatment.

We also recommend using a silicon sealant on the inside and outside of the windows as soon as possible after assembly and treatment to fully seal the windows.

Roofing felt/covering should be checked annually and replaced or fixed accordingly.

## 4 General maintenance and wood characteristics

As wood is a natural material it may be affected by the following:

Shrinkage and warping - The timber used in the construction of your garden building will have retained some of its natural moisture content. The moisture content of the timber will vary, depending upon prevailing environmental conditions, which will result in the components either naturally expanding or contracting. As the components dry out, shrinkage may occur. A good waterproofing treatment from the start is the best protection to minimise the effect of moisture loss/intake.

In extended periods of very warm weather getting some moisture to the building will help the overall balance. You can do this by spraying it down lightly with a garden hose. In contrast, after snow fall try to remove the snow as best as possible from the roof to prevent moisture intake and to remove the extra weight.

**Top tip** - using a garden brush will help you to reach the highest part of the building to remove snow and any debris left from bad weather.

Damp and mould - During the winter months, cold and damp conditions can result in an increased amount of moisture within your garden building, especially when used infrequently. Condensation can form on the timber and other items stored within your garden building. If left this moisture is likely to cause mould and mildew.

To prevent the build-up of moisture, we recommend leaving the door or windows of your building open from time to time, to allow the fresh air to circulate. We also advise against storing wet or damp items in your garden building as this will also increase the level of moisture in the building. If mould or mildew does start to form within your building we recommend using an anti-mould cleaner to remove it and to prevent it spreading, which if left untreated could permanently damage your garden building.

Splits, cracks and knots - You may notice small splits and cracks in some components or holes may appear where knots shrink and fall out. This will not affect the structure of your Garden building however, if you wish to fill them this can be easily done using any good quality wood filler.

Sap - is naturally occurring in wood and may appear in some boards of your garden building. If you wish to remove the sap, we advise waiting until it is dry and then using a sharp knife to carefully remove it. If the removal of the sap causes a hole in the timber, we recommend using a good quality wood filler to fill it.

For more handy hints and tips on how to care and maintain your garden building please refer to the MGP Customer Portal at [www.mgplogistics.co.uk](http://www.mgplogistics.co.uk)

### Any further questions?



Contact our Customer Service Team via the MGP Customer Portal at: [www.mgplogistics.co.uk](http://www.mgplogistics.co.uk)



1

## Manufacturer's Warranty

All Mercia Garden Products are supplied with a 1 year warranty on all parts against manufacturing defects.

This warranty does not cover movement, warping or splitting of timber products over time.

This warranty will be voided if any of the following occur:

1. The building has been customised or modified/adapted in any way.
2. The person claiming is not the original purchaser of the building.
3. Any damage has been caused by or as a result of misuse.
4. The building has not been maintained and cared for in accordance to our advisories and manufacturer's recommendations.
5. The building has not been treated annually or as per the manufacturer's recommendations, please ensure receipts are kept to validate this claim.
6. The building has not been erected, fitted or installed as per the supplier instructions.
7. The building has not been erected on a suitable sized firm flat, solid level concrete/slab base or placed on pressure treated bearers.
8. The building is or has been placed with 2 feet (600mm) of any obstructions (walls, trees, plants, fences etc.) which can allow moisture to penetrate the timber.
9. The roofing felt has been incorrectly fitted or damaged, allowing water ingress, or has not been properly maintained.
10. Any windows and joints have not been sealed, inside and out, with silicone or other watertight sealant.
11. Any timber has been cut, pierced or drilled without subsequent application of approved cut-end treatment.

REGISTER FOR YOUR

**10 YEAR  
ANTI-ROT  
GUARANTEE TODAY**

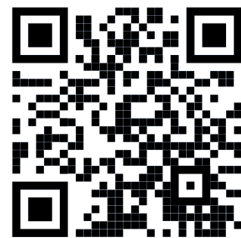

[www.mgplogistics.co.uk](http://www.mgplogistics.co.uk)

2

## Anti-rot Guarantee

Mercia Garden Products offer a 10 year anti-rot guarantee on all dip treated (a preparatory treatment) and 15 years on all pressure treated products. This guarantee covers solid timber against rot, decay, blue stain and insect attacks.

To validate the guarantee, the building must be treated (as detailed within manufacturer's recommendations) within 14 days (weather permitting) of assembly and annually thereafter.

This guarantee does not cover movement, warping or splitting of timber products over time.

This guarantee will be voided if any of the following occur:

1. The building has been customised or modified/adapted in any way.
2. The person claiming is not the original purchaser of the building.
3. Any damage is caused by or as a result of misuse.
4. The building has not been maintained and cared for in accordance to our advisories and manufacturer's recommendations.
5. The building has not been treated annually or as per the manufacturer's recommendations, please ensure receipts are kept to validate this claim.
6. The building has not been erected, fitted or installed as per the supplier instructions.
7. The building has not been erected on a suitable sized firm flat, solid level concrete/slab base or placed on pressure treated bearers.
8. The building is or has been placed with 600mm of any obstructions (walls, trees, plants, fences etc.) which can allow moisture to penetrate the timber.
9. The roofing felt has been incorrectly fitted or damaged allowing water ingress, or has not been properly maintained.
10. Any windows and joints have not been sealed, inside and out, with silicone or other watertight sealant.
11. Any timber has been cut, pierced or drilled without subsequent application of approved cut-end treatment.