

01D TOVAX10DDNWGP-V1

DIP TREATED OVERLAP APEX 10FT DOUBLE DOORS

BEFORE YOU START PLEASE READ INSTRUCTIONS CAREFULLY

- Check the pack and make sure you have all the items listed in the parts list provided.
- When you are ready to start, make sure you have the right tools at hand (not supplied - see the equipment list on next page).
- Ensure there is plenty of space and a clean dry area for assembly.
- Ensure you have enough time to build the product to ensure the building is water tight.

LOCATION FOR YOUR GARDEN BUILDING

A minimum of 600mm should be left around the perimeter of your garden building to allow access for maintenance, annual treatment and to allow air flow around the building.

Where possible you should avoid placing your garden building underneath large trees to prevent the tree causing damage to the building.

TIMBER

As with all natural materials, timber can be affected during various weather conditions. For the duration of heavy or extended periods of rain, swelling of the wood panels may occur. Warping of the wood may also occur during excessive dry spells due to an interior moisture loss. Unfortunately, these processes cannot be avoided but can be helped. It is suggested that the outdoor building is sprayed with water during extended periods of warm sunshine and sheltered as much as possible during rain or snow.

Once your garden building has been installed it will need to be treated within 14 days (weather permitting) and annually to prevent the timber from deteriorating and to waterproof it. This is required to maintain the anti-rot guarantee.

Dip Treated buildings - Require a preservative treatment to protect against rot and decay and a waterproof treatment to prevent water ingress

Pressure Treated buildings - Require a waterproof treatment to prevent water ingress

Log Cabins/Insulated Garden Rooms - Are supplied untreated and require a preservative and waterproofing treatment.

BUILDING A BASE

When thinking about where the building and where the base is going to be constructed: Ensure that there will be access to all sides for maintenance work and annual treatment.

Ensure the base is level and is built on firm ground, to prevent distortion. Refer to diagrams for the base dimensions, The base should be slightly smaller than the external measurement of the building, i.e. The cladding should overlap the base, creating a run off for water. It is also recommended that the floor be at least 25mm above the surrounding ground level to avoid flooding.

TYPES OF BASE

- Concrete 75mm laid on top of 75mm hard-core.
- Slabs laid on 50mm of sharp sand.
- Wooden base.

Whilst all products manufactured are made to the highest standards of safety and in the case of children's products independently tested to EN71 level, we cannot accept responsibility for your safety whilst erecting or using this product.



x2

All buildings should be erected by two adults



Winter = High Moisture = Expansion
Summer = Low Moisture = Contraction

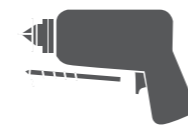

2mm Drill bit

For ease of assembly, you **MUST** pilot drill all screw holes and ensure all screw heads are countersunk.



CAUTION

Every effort has been made during the manufacturing process to eliminate the prospect of splinters on rough surfaces of the timber. You are strongly advised to wear gloves when working with or handling rough sawn timber.



For ease of assembly, you will need a tape measure to check dimensions of components.

Screws & Nails



Measure overall length

Bolts

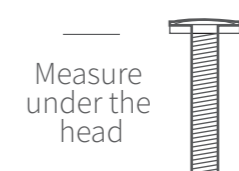

Measure under the head

To identify the fixings required for each step use a measuring tape.

****Protim Aquatan T5 (621)****

Your building has been dip treated with Aquatan.

Aquatan is a water-based concentrate which is diluted with water, the building as been treated by the correct application of Aquatan solution and then allowed to dry.

Aquatan is a decorative finish to colour the wood, which is applied industrially to timber fence panels and garden buildings.

Aquatan undiluted contains: boric acid, sodium hydroxide 32% solution, aqueous mixture of sodium dioctyl sulphosuccinat and alcohols: 2, 4, 6-trichlorophenol.



REGISTER FOR YOUR
ANTI-ROT
GUARANTEE TODAY

PLEASE SCAN HERE:



In all instances for assistance with your product, please contact us via our customer portal: <https://www.mgplogistics.co.uk/>.

Mercia Garden Products Limited,
Sutton On Trent,
Newark,
Nottinghamshire,
NG23 6QN

TO DO LIST

- Find a suitable location to build *(see front cover for further information).*
- Build a base *(see front cover for further information).*
- Check the base is flat, level, clear of debris and has 60cm clearance on all sides.
- Check you have the required equipment.
- Check you have all the product items listed *(if you have missing or damaged parts please contact the customer services department, see front cover for contact details).*
- Install the product as per the step by step instructions within this pack.
- Prepare the product ready for treatment.
- Apply a preserving and a waterproofing treatment within 14 days *(weather permitting)* of installation *(pressure treated products do not require a preserver).*
- Register for your anti rot guarantee *(scan the QR below).*
- Tidy the build area and dispose of any remaining parts responsibly.
- Maintain your building *(see the manufacturers recommendations at the back of this pack).*

EQUIPMENT LIST

- Hammer
- Flat Head Screwdriver
- Drill
- Drill Bit Set
- Phillips and Slotted Bit Sets
- Tape Measure
- Hand Saw
- Spirit Level
- Ladders/Steps
- Stanley Knife/Cutting Tool
- Sand Paper
- Gloves
- Silicone (For Windows Only)
- Wood Filler (Optional)
- Timber Preservative Treatment *(not pressure treated products)*
- Timber Water Proofing Treatment
- Treatment Mixing Stick
- Paint Brush/Sprayer/Roller

NEED EXTRA SUPPORT

If you are unsure that your base preparation will be suitable, please contact us on 01636 821215 to discuss this further.

Alternatively, you can visit our website or MGP Logistics Online Portal for some further shededucation.

Website:

<https://www.merciagardenproducts.co.uk/sheducation>

MGP Logistics Online Portal:

<https://www.mgplogistics.co.uk/>

Here you will find plenty of useful information that'll help with most pre-installation and maintenance queries.

PLEASE SCAN HERE:

**ANY QUESTIONS?**

Scan the QR code to contact us via our customer portal.

NOTES

ACCESSING VIDEO GUIDES...

Some steps within this set of instructions come with an added video guide for your convenience. These can be accessed via the QR code and used to aid you in constructing that step. See below for how to use.

You can also find all the videos on our youtube channel:
<https://www.youtube.com/@merciagardenproducts8716/videos>

1. Find the QR code within the instruction step...

Step.....

Parts Needed- No. QTY 1
No. QTY 1
No. QTY 1



Within the instruction step, there will be an icon in the top right that has a QR code in. This is where the video can be accessed from.

Please note: not every step has a video guide.

2. Open camera app...

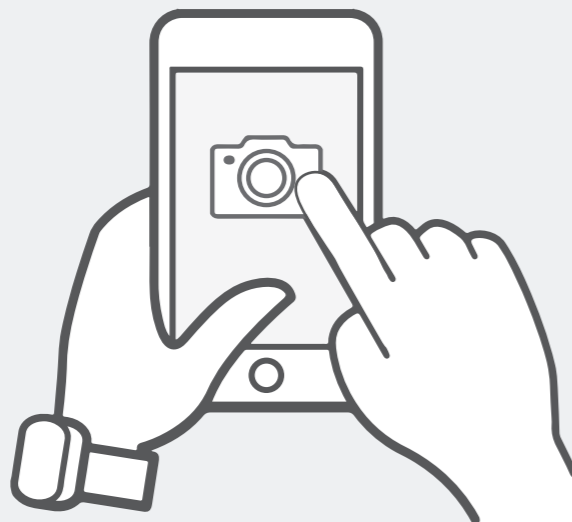

On your personal smart device (phone, tablet etc), open your camera app or QR code scanner app.

ACCESSING VIDEO GUIDES...

3. Scan QR code...



To scan the QR code, hold the camera over the QR code so that it can be seen on the screen. Once the QR code has been registered, follow the prompts on your device to open the video. (This will vary depending on your device.)

Please note: Ensure to use the back camera of your smart device as this will scan the QR code more accurately.

4. Watch the video...



The video guide will now be displayed on your smart device.

Disclaimer: The garden building constructed in the video guides may be constructed differently to your building. Please ensure to read your instructions carefully to avoid error.

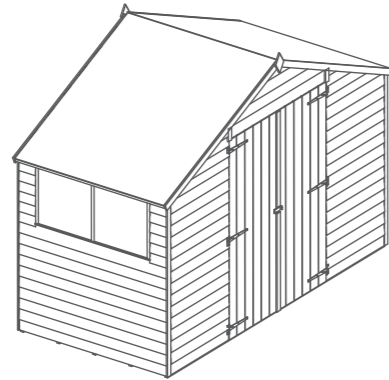

5X10 Apex With Windows

Overall Dimensions: Width = 3099mm
 Depth = 1537mm
 Height = 2321mm
Base Dimensions: Width = 2970mm
 Depth = 1456mm

Pack Requirements:
 01DTOVAX10DDNWGP-V1 QTY 1
 01DTOVAX0510FWPB-V1 QTY 1

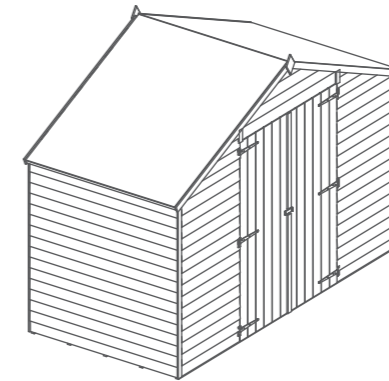

5X10 Apex No Windows

Overall Dimensions: Width = 3099mm
 Depth = 1537mm
 Height = 2321mm
Base Dimensions: Width = 2970mm
 Depth = 1456mm

Pack Requirements:
 01DTOVAX10DDNWGP-V1 QTY 1
 01DTOVAX0510NWPB-V1 QTY 1

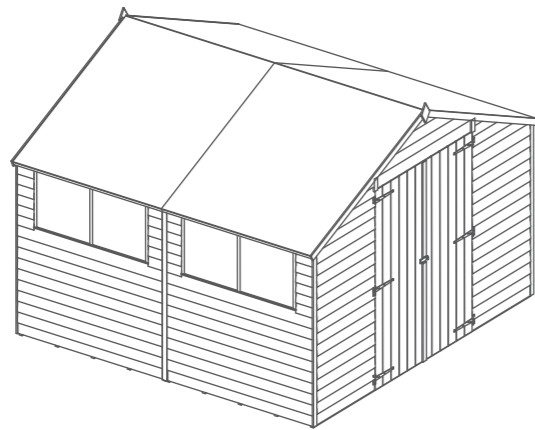

10X10 Apex With Windows

Overall Dimensions: Width = 3099mm
 Depth = 2998mm
 Height = 2321mm
Base Dimensions: Width = 2970mm
 Depth = 2912mm

Pack Requirements:
 01DTOVAX10DDNWGP-V1 QTY 1
 01DTOVAX0510FWPB-V1 QTY 2

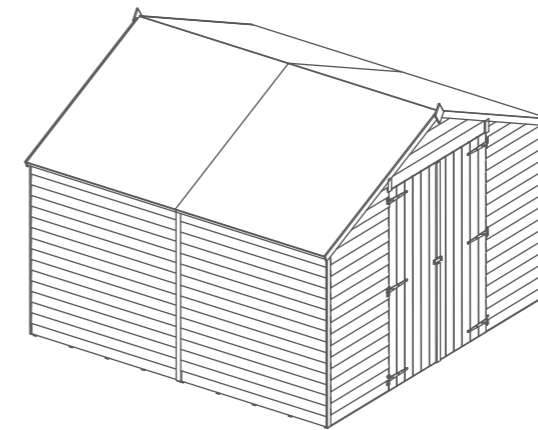

10X10 Apex No Windows

Overall Dimensions: Width = 3099mm
 Depth = 2998mm
 Height = 2321mm
Base Dimensions: Width = 2970mm
 Depth = 2912mm

Pack Requirements:
 01DTOVAX10DDNWGP-V1 QTY 1
 01DTOVAX0510NWPB-V1 QTY 2

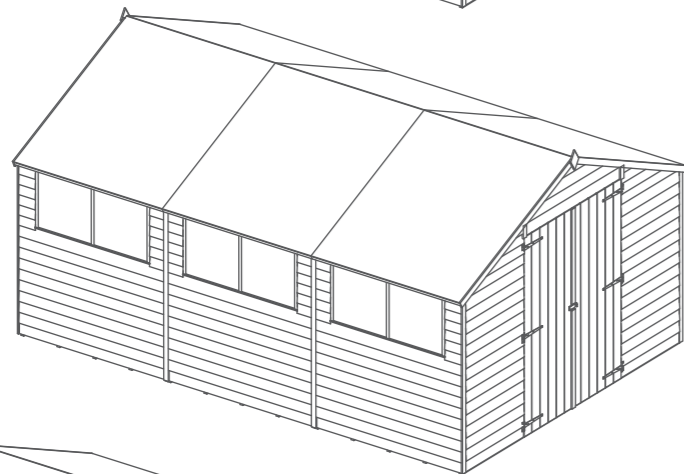

15X10 Apex With Windows

Overall Dimensions: Width = 3099mm
 Depth = 4459mm
 Height = 2321mm
Base Dimensions: Width = 2970mm
 Depth = 4368mm

Pack Requirements:
 01DTOVAX10DDNWGP-V1 QTY 1
 01DTOVAX0510FWPB-V1 QTY 3

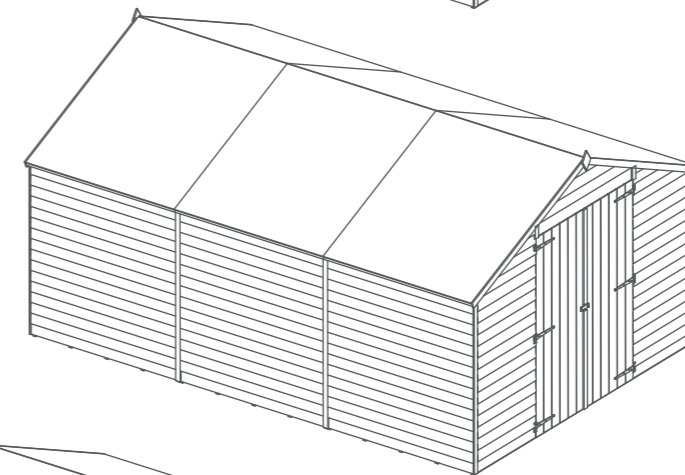

15X10 Apex No Windows

Overall Dimensions: Width = 3099mm
 Depth = 4459mm
 Height = 2321mm
Base Dimensions: Width = 2970mm
 Depth = 4368mm

Pack Requirements:
 01DTOVAX10DDNWGP-V1 QTY 1
 01DTOVAX0510NWPB-V1 QTY 3

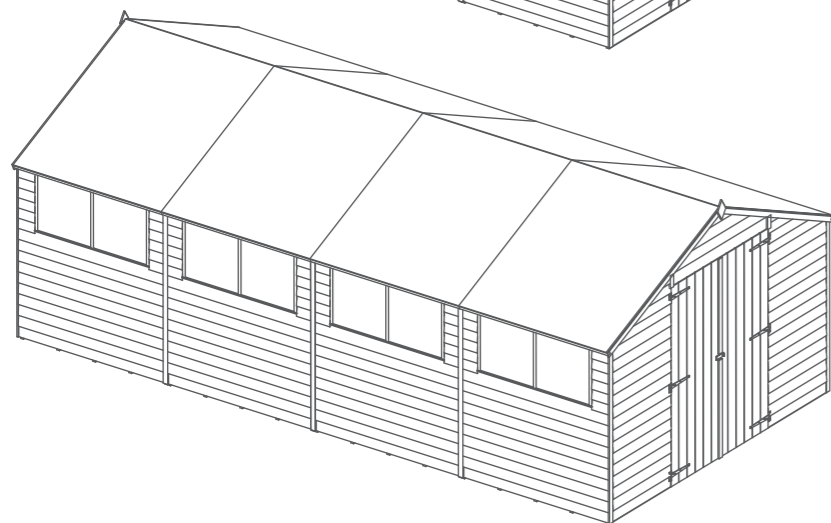

20X10 Apex With Windows

Overall Dimensions: Width = 3099mm
 Depth = 5920mm
 Height = 2321mm
Base Dimensions: Width = 2970mm
 Depth = 5824mm

Pack Requirements:
 01DTOVAX10DDNWGP-V1 QTY 1
 01DTOVAX0510FWPB-V1 QTY 4

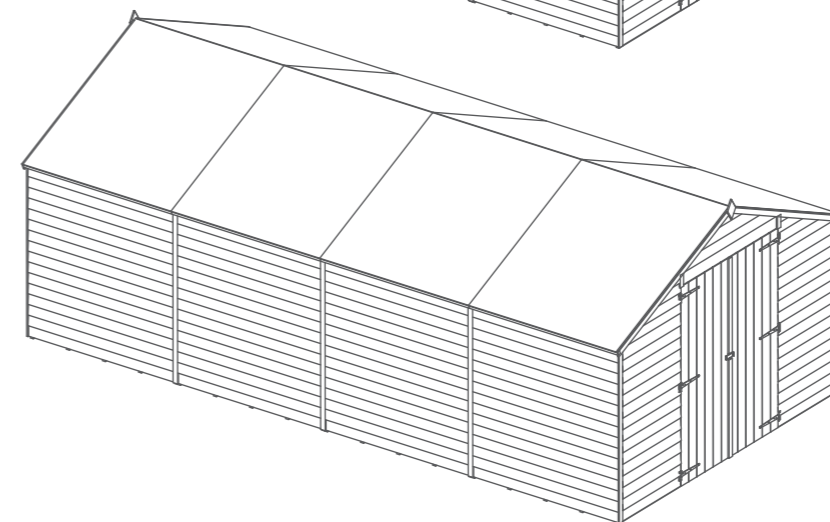

20X10 Apex No Windows

Overall Dimensions: Width = 3099mm
 Depth = 5920mm
 Height = 2321mm
Base Dimensions: Width = 2970mm
 Depth = 5824mm

Pack Requirements:
 01DTOVAX10DDNWGP-V1 QTY 1
 01DTOVAX0510NWPB-V1 QTY 4

Building Contents- Gable Pack

01DTOVAX10DDNWGP-V1

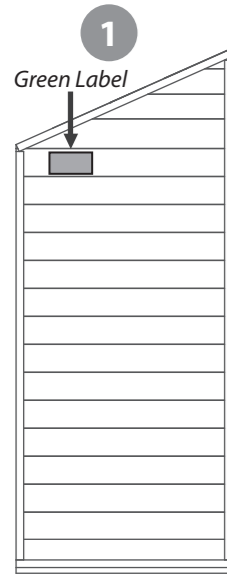

Front Gable Right QTY 1
AI-01R11OV PGL796X1934-V1

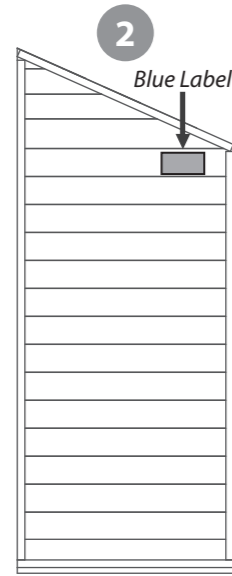

Front Gable Left QTY 1
AI-01R11OV PGL796X1934-V1

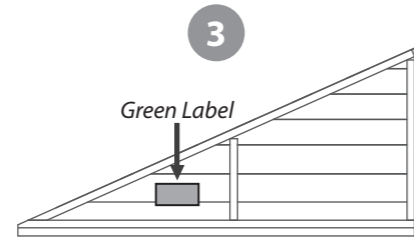

Back Gable Top Right QTY 1
AI-R11OVHAGTR692X1461-V1

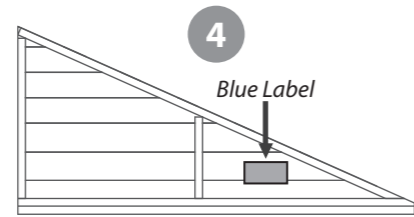

Back Gable Top Left QTY 1
AI-R11OVHAGTL692X1461-V1

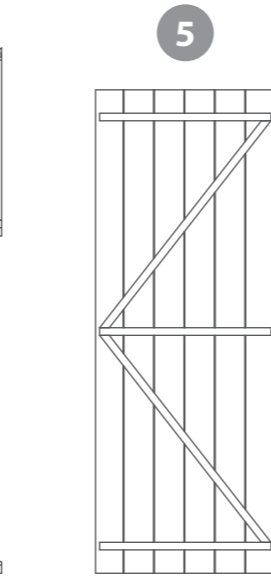

Door QTY 2
AI-R11FBMBZBD661X1780-V1

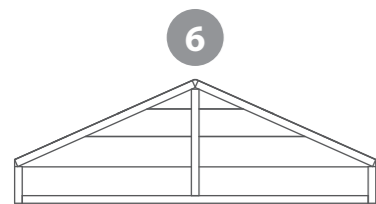

Gable Top QTY 1
AI-R11OVAGT1330X455-V1

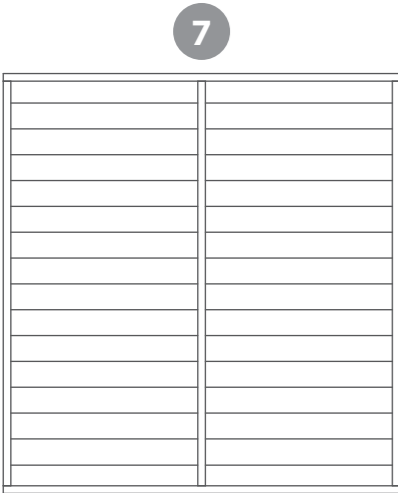

Plain Panel QTY 2
AI-R11OVPP1461X1567-V1



Front Panel Cover Strip 12x45x115mm QTY 2
S1245-115mm



Door Strip 12x45x848mm QTY 1
S1245-848mm



Door Strip 12x45x876mm QTY 1
S1245-876mm



Back Cover Trim 12x45x635mm QTY 1
S1245-635mm



Door Block 28x28x150mm QTY 4
F2828-150mm



Door Framing 28x28x1330mm QTY 1
F2828-1330mm



Ridge Bar 27x70x1405mm QTY 1
F2770-1405mm



Fascias 12x56x1671mm QTY 4
S1256-1671mm



Cover Trim 12x45x1542mm QTY 5
S1245-1542mm



Back Gable Cover Strip 7x125x2090mm QTY 1
OVL P7125-2090mm



Front Gable Cover Strip 7x125x1876mm QTY 1
OVL P7125-P-1876mm



Door Beading Strip 12x28x1700mm QTY 2
S1228-1700mm

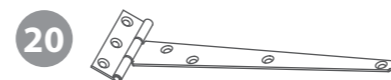

T Hinge QTY 6
PI-07-0021



Corner Brace QTY 2
PI-07-0012



Turn Button QTY 2
PI-07-0034



Shed Diamond Finial QTY 2
Shed Diamond Finial

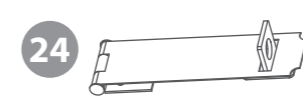

Hasp and Staple QTY 1
PI-07-0207

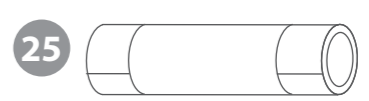

Felt

Nail Bag







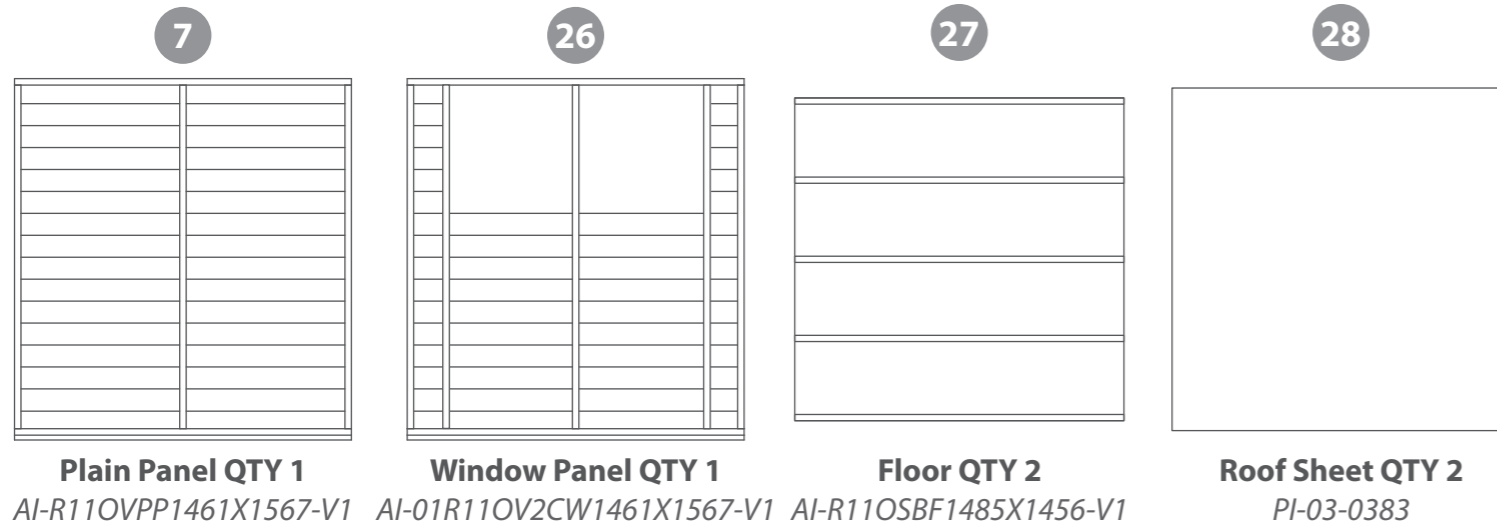

There may be extra screws present in the nail bag



Building Contents- Window Pack



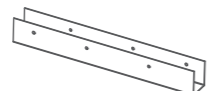

01D0VAX0510FWPB-V1





- 16**  **Cover Trim 12x45x1542mm QTY 2**
S1245-1542mm
- 29**  **Eaves Framing 28x28x1473mm QTY 2**
F2828-1473mm
- 30**  **Truss Support 27x44x1850mm QTY 2**
F2744-G-1890mm
- 31**  **Ridge Bar 27x70x1444mm QTY 1**
F2770-1444mm
- 32**  **Truss Framing 44x44x1602mm QTY 2**
F4444-G-1642mm
- 33**  **Window Strips 12x27x546mm QTY 5**
S1227-546mm
- 34**  **U Channel QTY 1**
PI-07-0013
- 35**  **Styrene QTY 2**
PI-05-0114
- 36**  **Window Cill QTY 1**
PI-08-0013

Nail Bag

There may be extra screws present in the nail bag









-  50mm Screw x 42
-  40mm Screw x 19
-  30mm Screw x 62
-  Felt Tacks x 100

- 37**  **Truss Support 44x44x345mm QTY 1**
F4444-G-385mm
- 38**  **Floor Blocks 28x28x400mm QTY 4**
F2828-400mm
- 39**  **Truss Block 27x44x140mm QTY 2**
F2744-G-160mm

Building Contents- No Window Pack



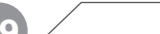

01D0VAX0510NWPB-V1



- 16**  **Cover Trim 12x45x1542mm QTY 2**
S1245-1542mm
- 29**  **Eaves Framing 28x28x1473mm QTY 2**
F2828-1473mm
- 30**  **Truss Support 27x44x1850mm QTY 2**
F2744-G-1890mm
- 31**  **Ridge Bar 27x70x1444mm QTY 1**
F2770-1444mm
- 32**  **Truss Framing 44x44x1602mm QTY 2**
F4444-G-1642mm
- 34**  **U Channel QTY 1**
PI-07-0013
- 37**  **Truss Support 44x44x345mm QTY 1**
F4444-G-385mm
- 38**  **Floor Blocks 28x28x400mm QTY 4**
F2828-400mm
- 39**  **Truss Block 27x44x140mm QTY 2**
F2744-G-160mm

Nail Bag

There may be extra screws present in the nail bag

-  50mm Screw x 42
-  40mm Screw x 19
-  30mm Screw x 44
-  Felt Tacks x 100

Pre Assembly

Before assembling remove the transportation blocks from the bottom of each panel.

Take care removing the blocks as to not damage the panels. Tap with a flat headed screwdriver and hammer.

Dispose of the blocks once removed.

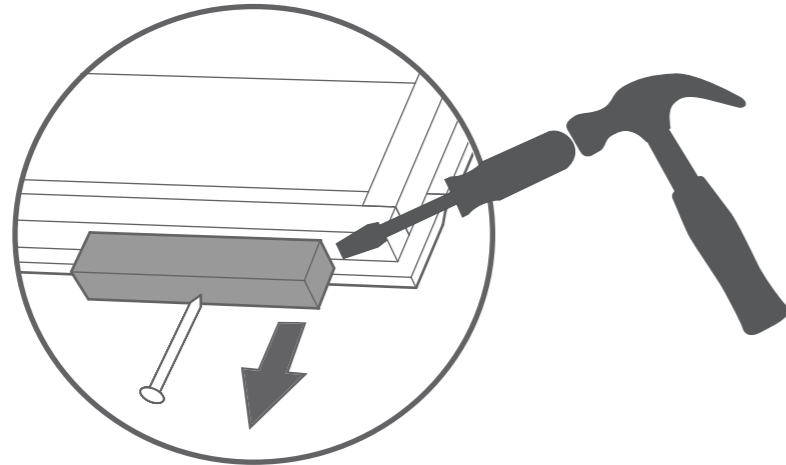

PLEASE SCAN HERE:



Step 2

Parts Needed	Building Size
No.18	All Sizes
40mm Screws	QTY 6

Lay the Front Gable Cover Strip (**No.18**) onto the assembled front gable, align the edges of the strip with the top of the gable and secure using 6x40mm screws, ensuring to go through the strip and into the framing.



IMPORTANT: Pre-drill before fixing screws.

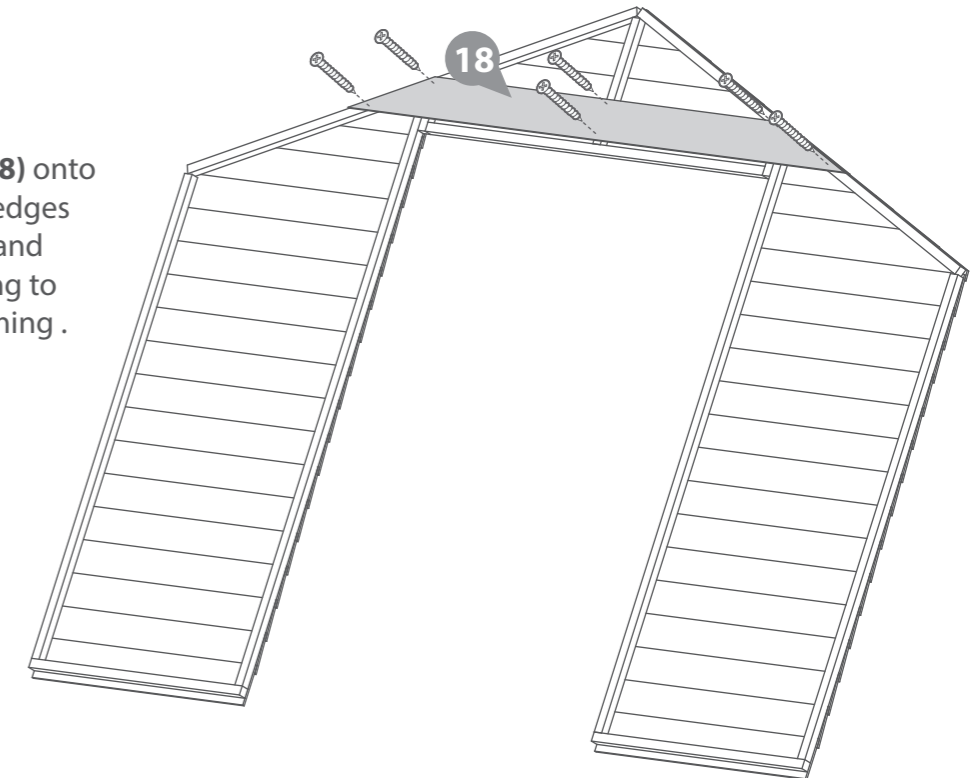

Step 1

Parts Needed	Building Size
No.1	All Sizes
No.2	QTY 1
No.6	QTY 1
50mm Screws	QTY 4

Lay the Front Gable Right and Left (**No.1 and No.2**) and the Gable top (**No.6**) onto a level floor.

Place them along side each other and ensure they are flush along the top of the panels. Secure the panels using 2x50mm screws along each join in an alternating pattern.

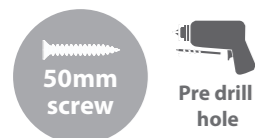

IMPORTANT: Pre-drill before fixing screws.

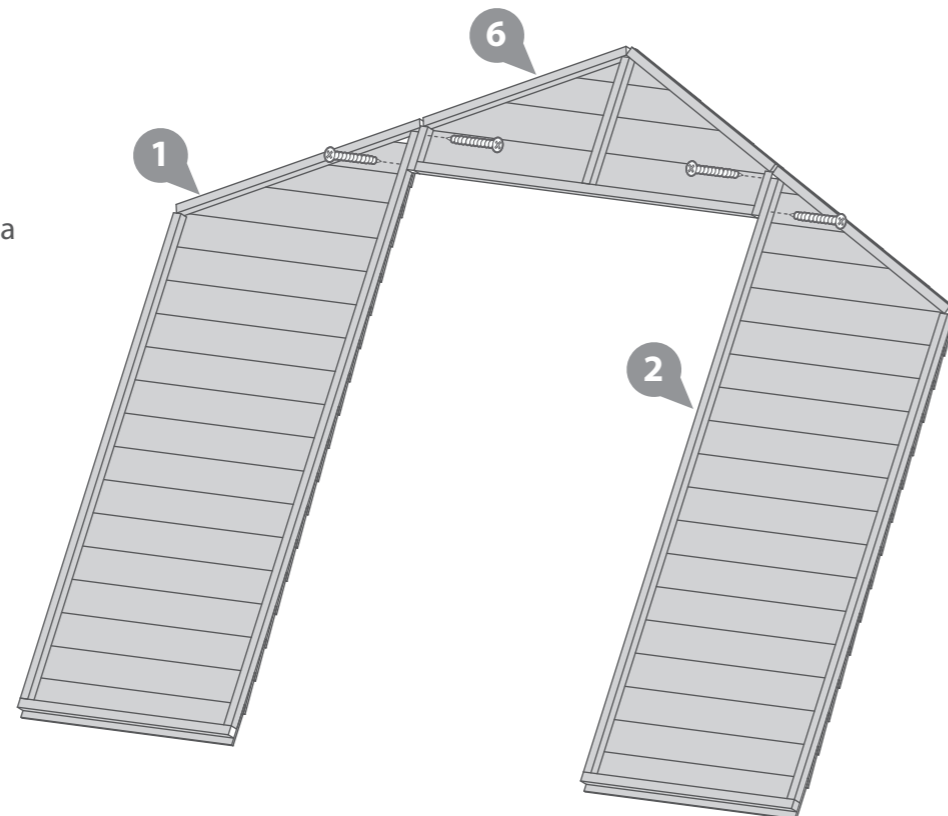

Step 3

Parts Needed	Building Size
No.3	All Sizes
No.4	QTY 1
No.7	QTY 2
50mm Screws	QTY 12

Lay the Back Gable Top Right (**No.3**) and a Plain Panel (**No.7**) onto a level floor.

Place the Back Gable top onto the plain panel, ensuring the gable top cladding slots over the plain panel as shown in the illustration. The Back Gable top should sit flush with the plain panel framing.

Secure the the Back Gable top to the plain panel using 6x50mm screws in an alternating pattern.

Repeat this step with the Back Gable top Left to create a left side assembly.

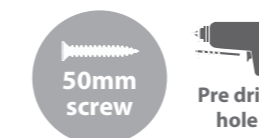

IMPORTANT: Pre-drill before fixing screws.

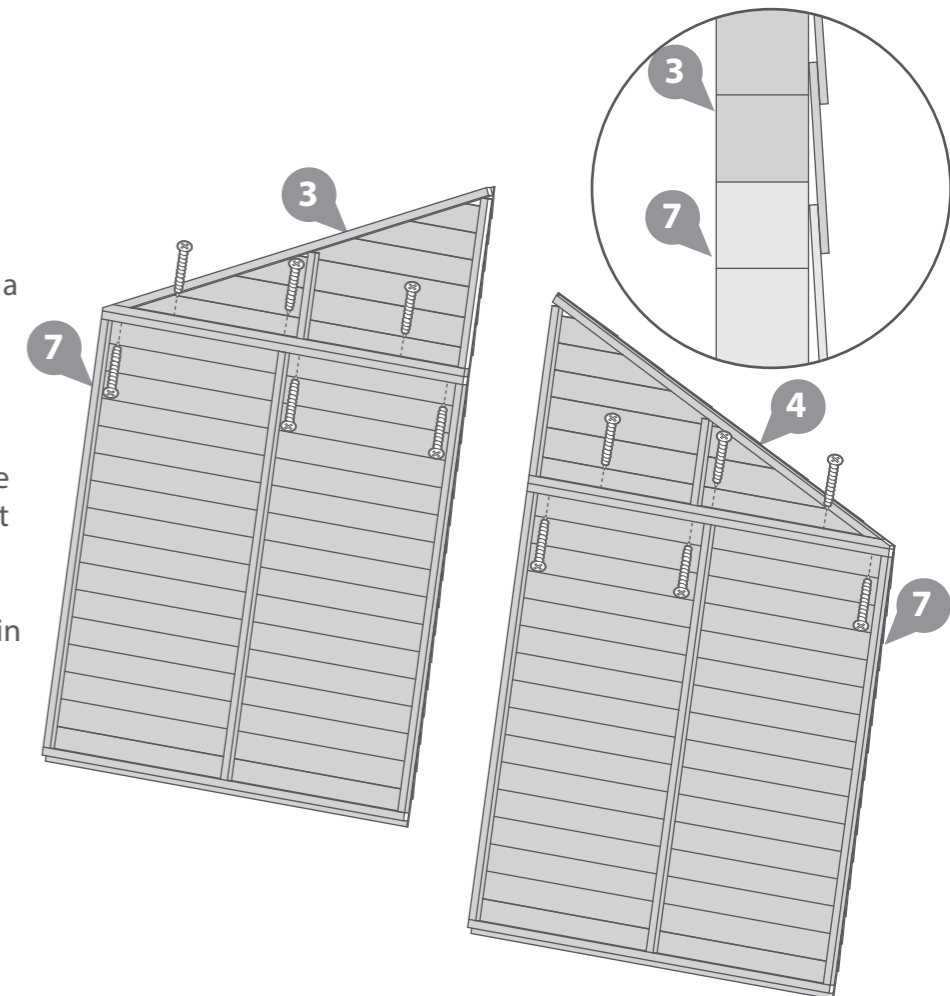

IMPORTANT: Pre-drill before fixing screws.

Step 4

Parts Needed	Building Size
50mm Screws	All Sizes QTY 10

Lay the assembled Back Panels along side each other, ensure they are flush at the bottom and secure using 10x50mm screws in an alternating pattern.

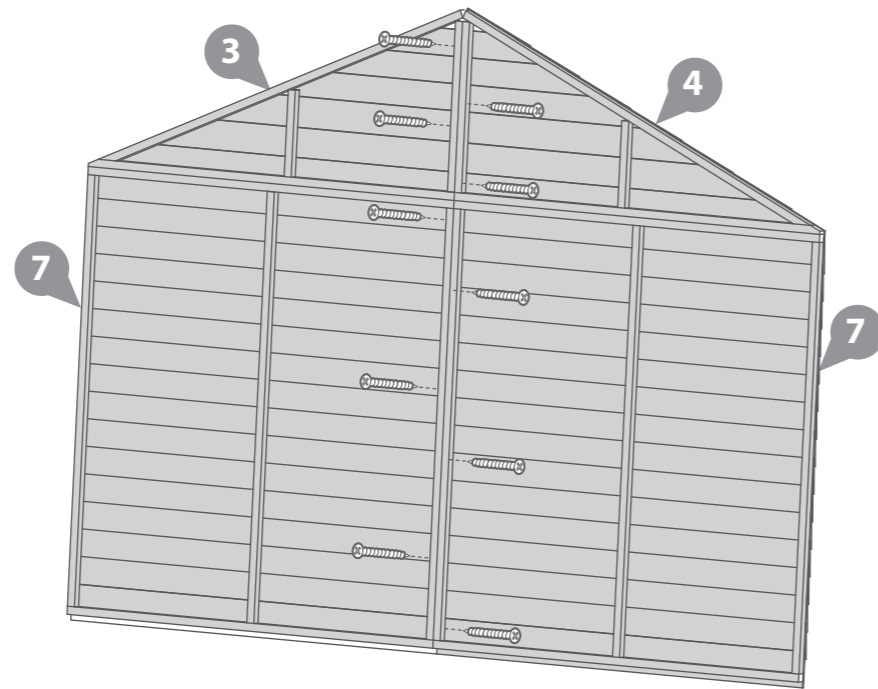
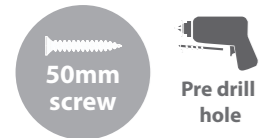

IMPORTANT: Pre-drill before fixing screws.

Step 6

Parts Needed	Building Size			
No.27	5x10 QTY 2	10x10 QTY 4	15x10 QTY 6	20x10 QTY 8
No.38	QTY 4	QTY 8	QTY 12	QTY 16
30mm Screws	QTY 16	QTY 32	QTY 48	QTY 64

Place the floors (No.27) along side each other as shown in the diagram, locate the Floor blocks (No.38) between the floors, equally spaced. Secure the blocks to the floors using 4x30mm screws per block, going through the floor OSB and into the blocks below.

Repeat this step to create the remaining floor assemblies.

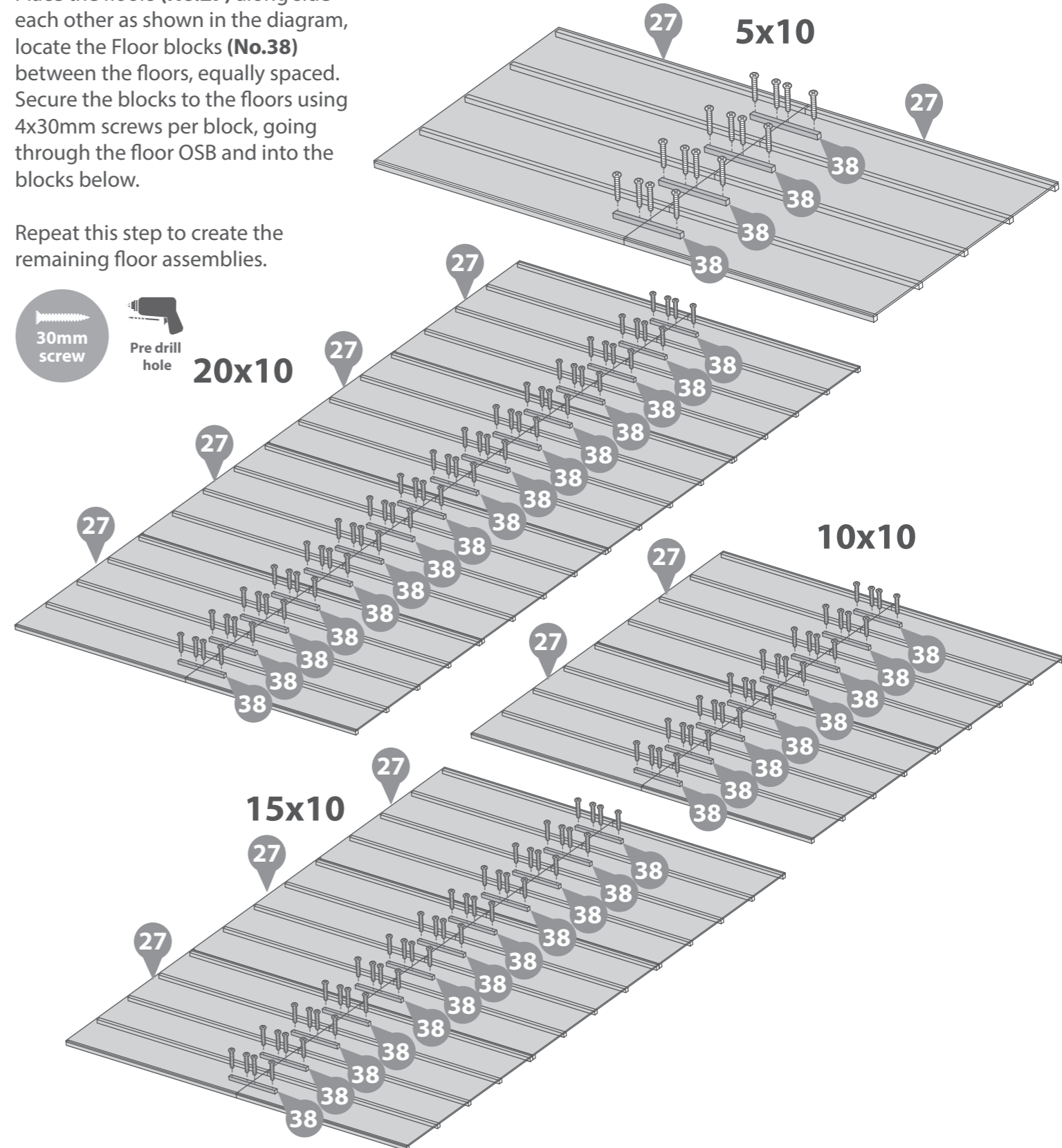

Step 5

Parts Needed	Building Size
No.17	All Sizes QTY 1
40mm Screws	QTY 5

Lay the Back Gable Cover Strip (No.17) onto the assembled front gable, align the edges of the strip with the top of the gable and secure using 5x40mm screws, ensuring to go through the strip and into the framing.

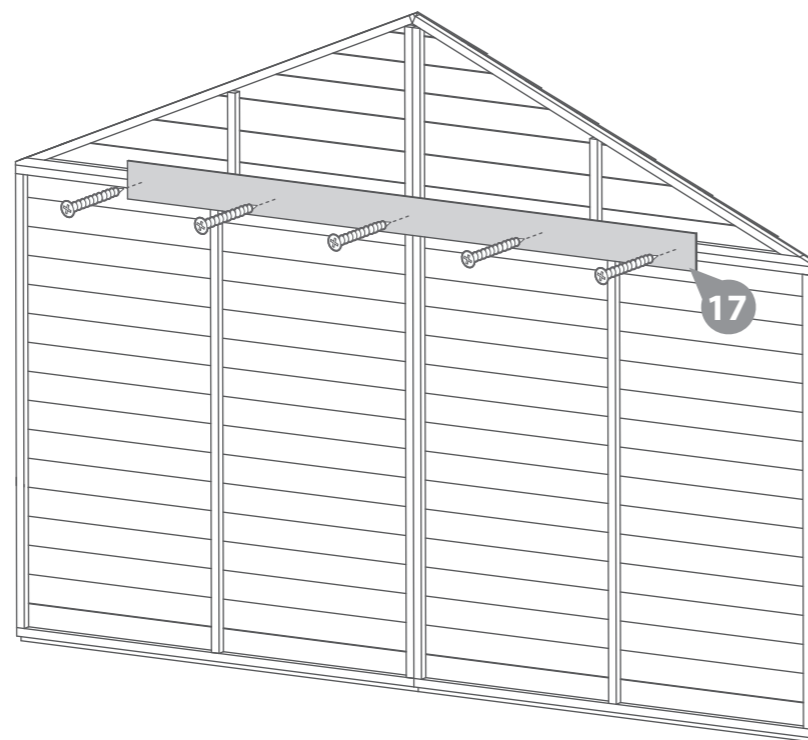
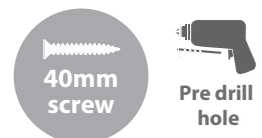

IMPORTANT: Pre-drill before fixing screws.

Step 7 *For 5x10 Buildings, please move onto Step 8

	Building Size		
Parts Needed	10x10	15x10	20x10
No.27	QTY 4	QTY 6	QTY 8
40mm Screws	QTY 12	QTY 24	QTY 36

Place the assembled floors (No.27) along side each other as shown in the diagram, Secure the floors together using 12x40mm screws per join. Ensure to go through the floor cladding and into the framing.

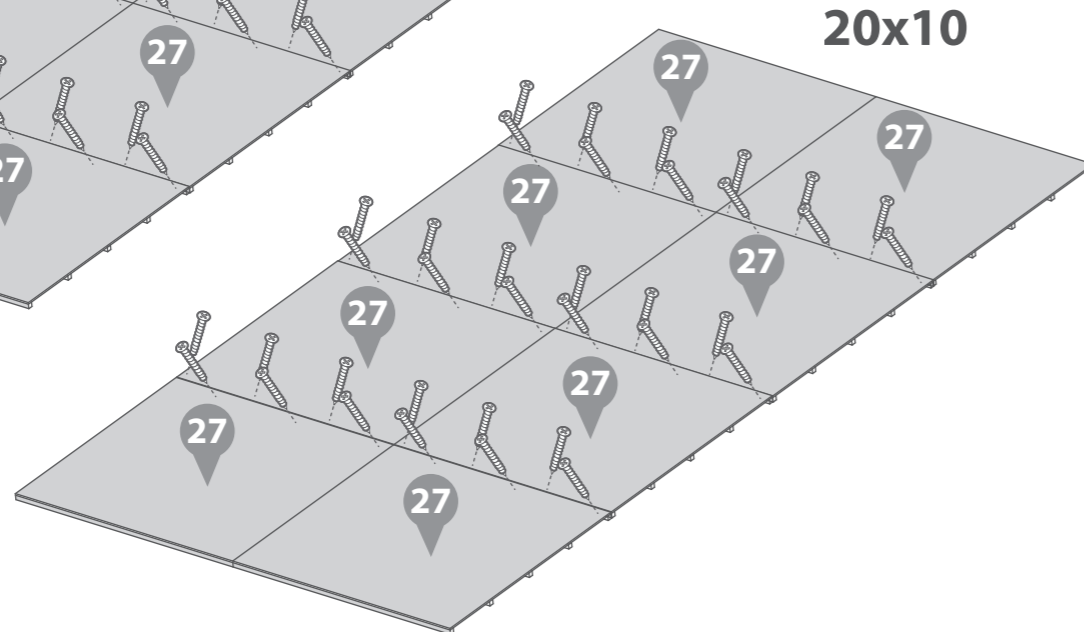
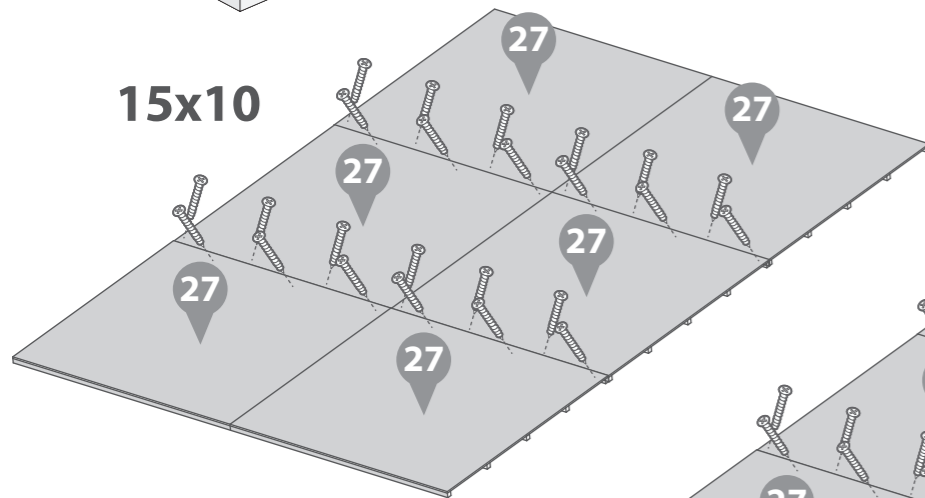
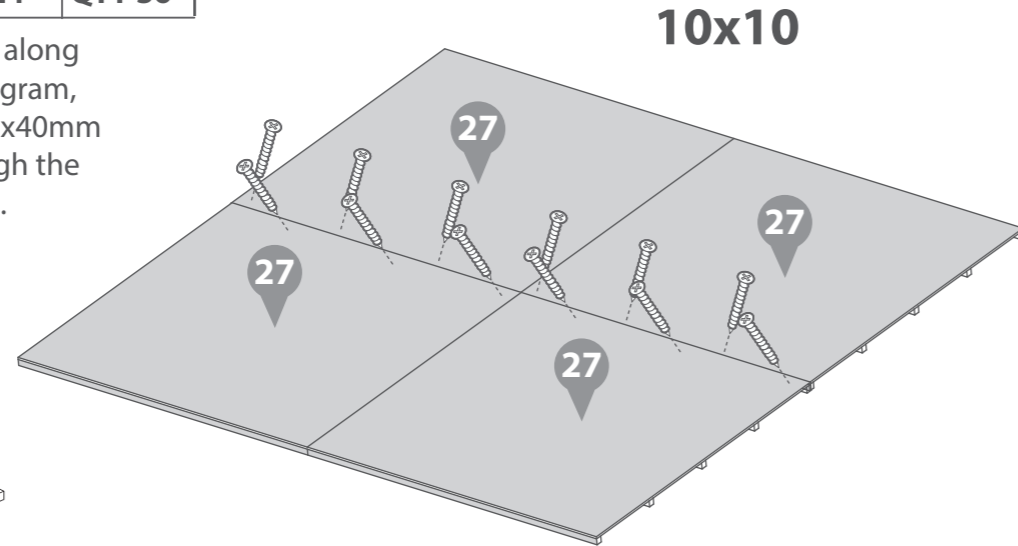
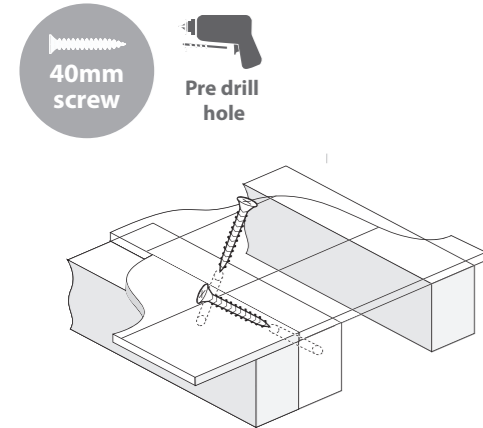

IMPORTANT: Pre-drill before fixing screws.

Step 8

	Building Size
Parts Needed	All Sizes
No.7	QTY 1
50mm Screws	QTY 4

Locate the Plain Panel (No.7) onto the floor. Fix to the Back Gable Assembly at the corner with 4x50mm screws as shown in diagram.

Do not secure the building to the floor until the roof is fitted.

Position the panels so there is equal spacing between the floor and cladding on all sides.

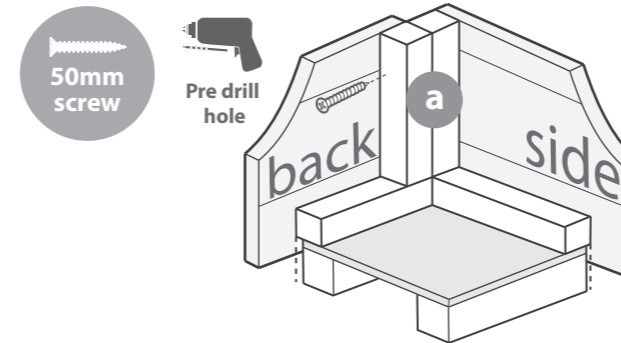

Please note: Whether you have purchased the with windows building or no windows building, the Window panel and plain panel are interchangeable. Decide which works best before assembly.*

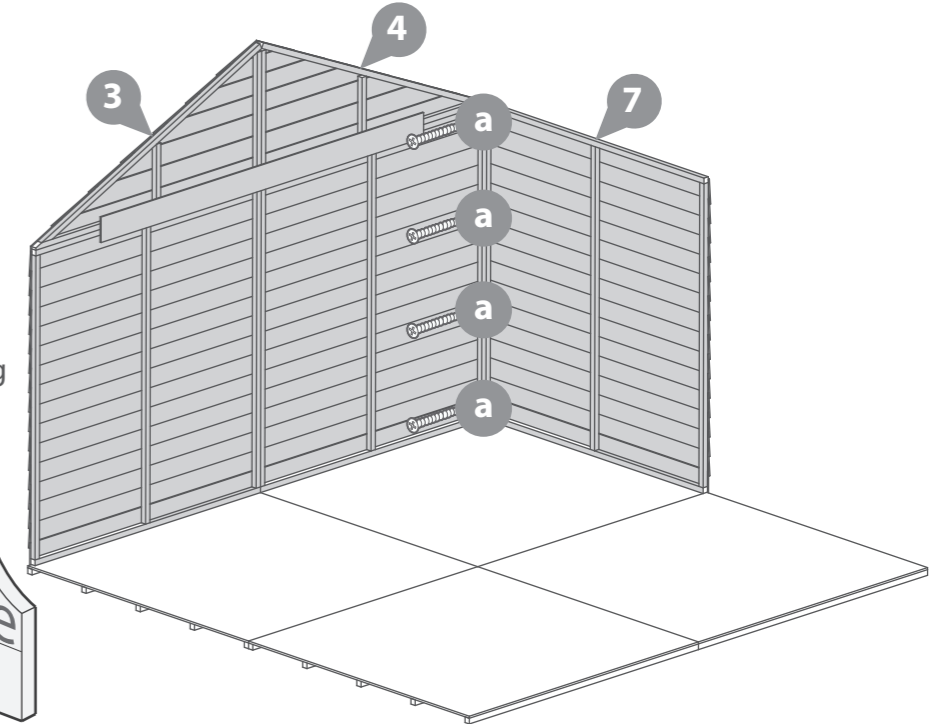

IMPORTANT: Pre-drill before fixing screws.

Step 9

	Building Size
Parts Needed	All Sizes
No.26	QTY 1
50mm Screws	QTY 4

Locate either the Window Panel (No.26) or the Plain Panel (No.7) onto the floor. Fix to the Back Gable Assembly at the corner with 4x50mm screws as shown in diagram.

Do not secure the building to the floor until the roof is fitted.

Position the panels so there is equal spacing between the floor and cladding on all sides.

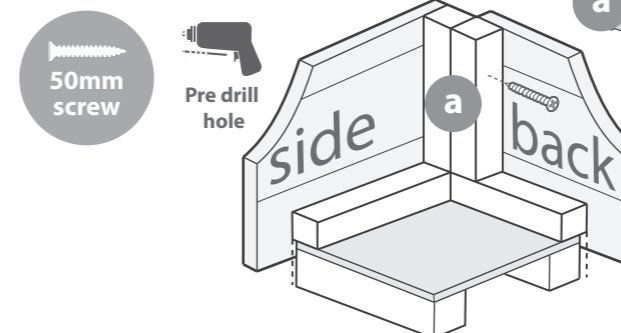

Please note: Whether you have purchased the with windows building or no windows building, the Window panel and plain panel are interchangeable. Decide which works best before assembly.*

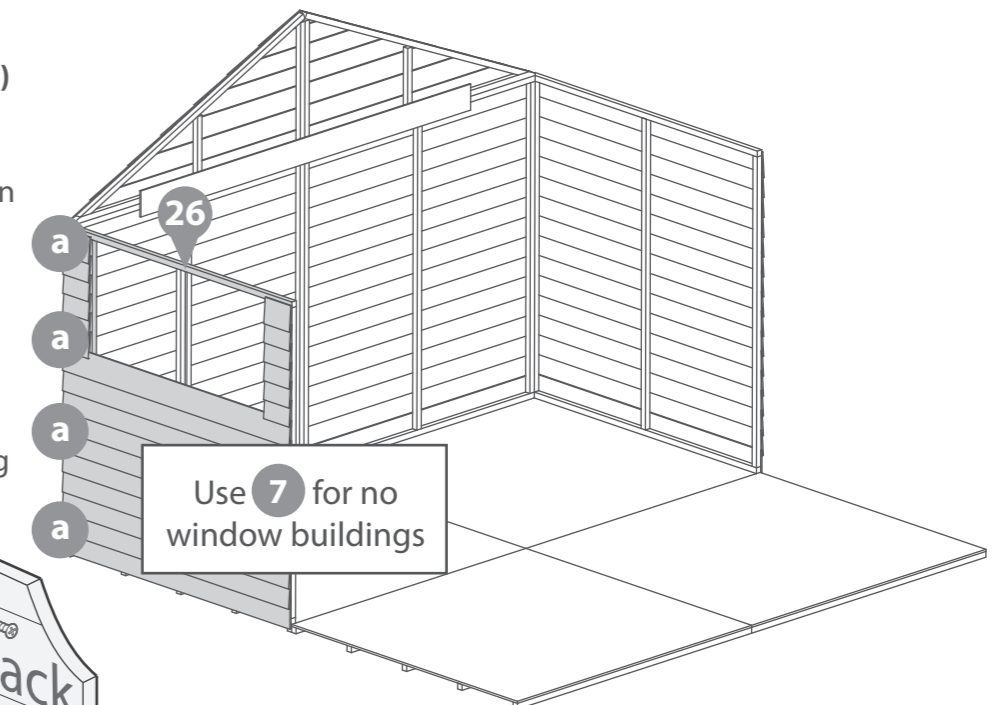

IMPORTANT: Pre-drill before fixing screws.

Step 10 *For 5x10 Buildings, please move onto Step 11

IMPORTANT: Pre-drill before fixing screws.

Parts Needed	Building Size		
	10x10	15x10	20x10
No.7	QTY 1	QTY 2	QTY 3
No.26	QTY 1	QTY 2	QTY 3
50mm Screws	QTY 8	QTY 16	QTY 24

Using the same method continue to fix either Window Panels (**No.26**) or Plain Panels (**No.7**) on to your shed. Fix at the joints using 4x50mm screws per join in an alternating pattern as shown in the diagram.

Ensure to position the panel so there is equal spacing between the floor and cladding on each side.

Do not secure the building to the floor until the roof is fitted.

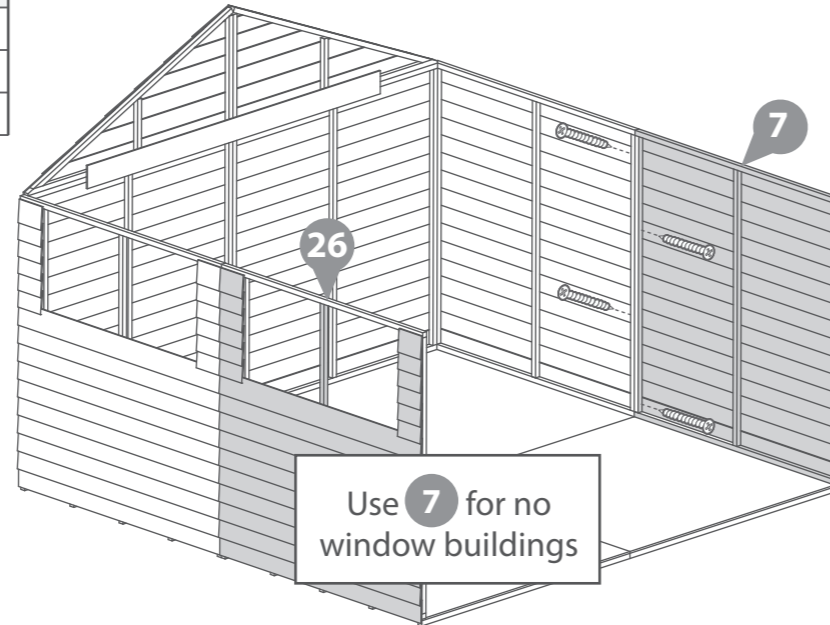
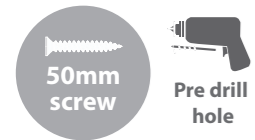

Use **7** for no window buildings

****Please note: Whether you have purchased the with windows building or no windows building, the Window panel and plain panel are interchangeable. Decide which works best before assembly.****

15x10

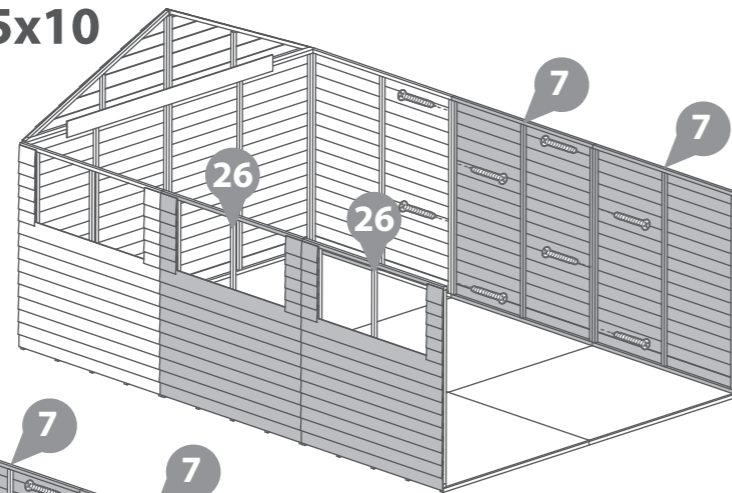

20x10

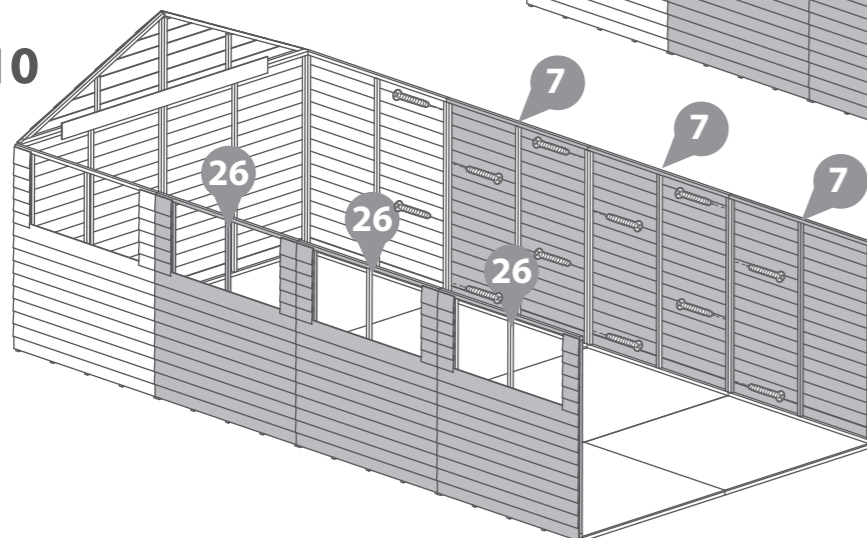

Step 11

Parts Needed	Building Size
50mm Screws	All Sizes QTY 8

Locate the front Gable assembly onto the floor and secure at the corners using 4x50mm screws at each corner.

Ensure to position the panel so there is equal spacing between the floor and cladding on each side.

Do not secure the building to the floor until the roof is fitted.



IMPORTANT: Pre-drill before fixing screws.

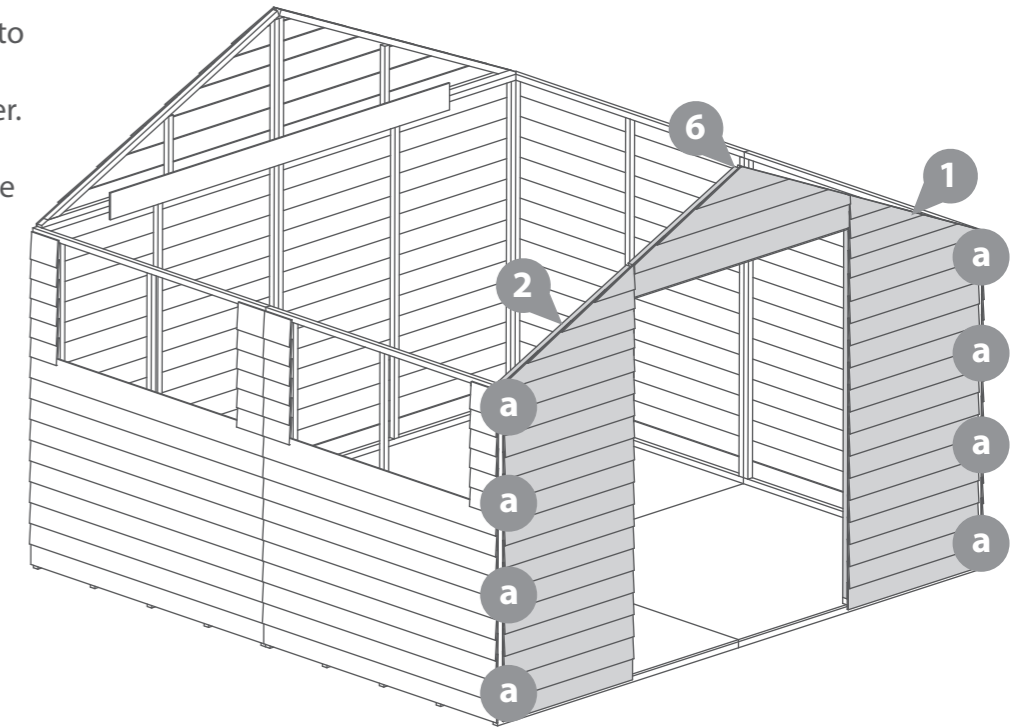

Step 12

Parts Needed	Building Size
No.13	All Sizes QTY 1
50mm Screws	All Sizes QTY 3

Fit the Door Framing (**No.13**) between the Front Gable Left and Right. Fix to the floor using 3x50mm screws making sure the screws go through to the floor framing.



IMPORTANT: Pre-drill before fixing screws.

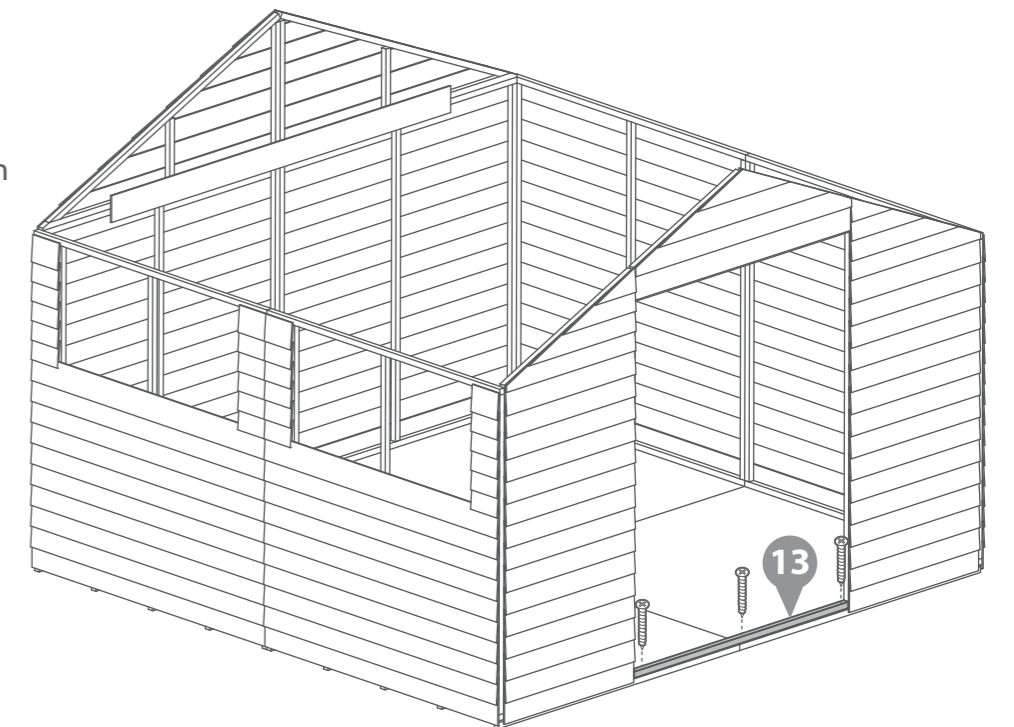

Step 13 *For 5x10 Buildings, please move onto Step 16 **IMPORTANT: Pre-drill before fixing screws.**

Parts Needed	Building Size		
	10x10	15x10	20x10
No.39	QTY 2	QTY 4	QTY 6
50mm Screws	QTY 4	QTY 8	QTY 12

Position the truss block (No.39) at the top of the side panels framing, The base of the truss block should be spaced 164mm away from the top of the panel framing.

Aligning the block centrally along the join between the panels. Fix in place by screwing through the block into the panel framing using 2x50mm screws.

Repeat for remaining blocks.

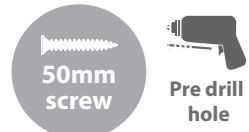
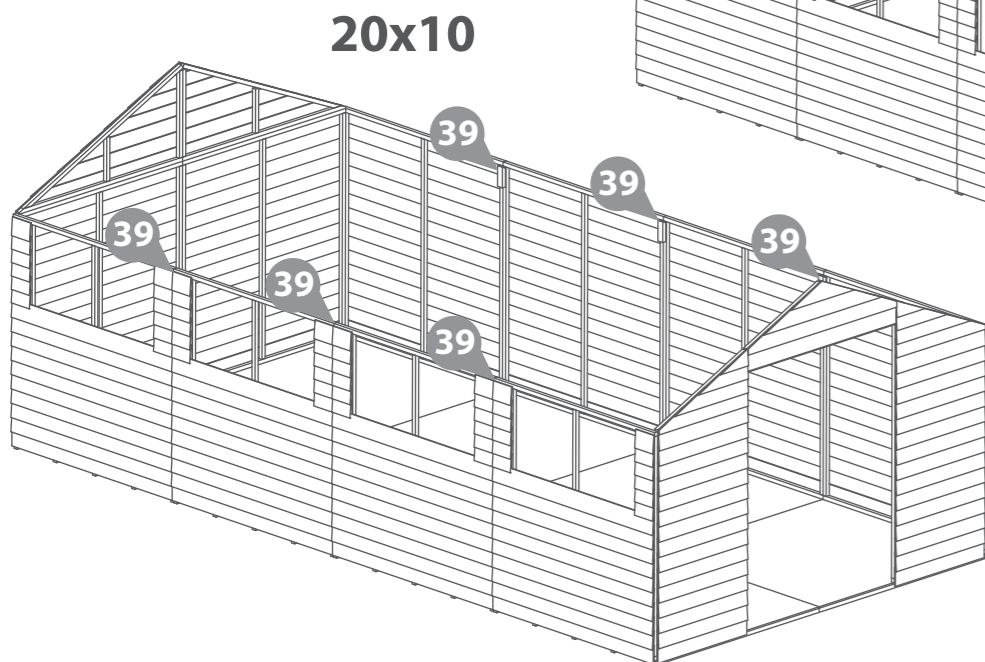
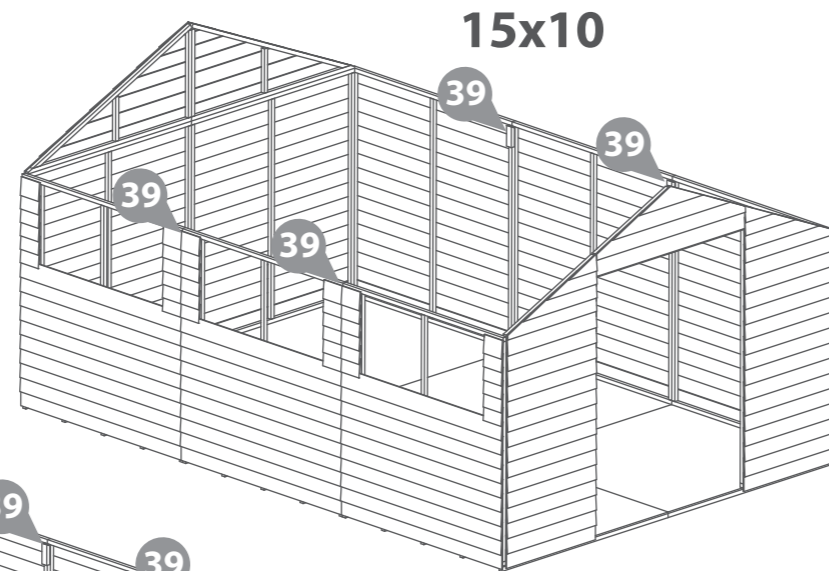
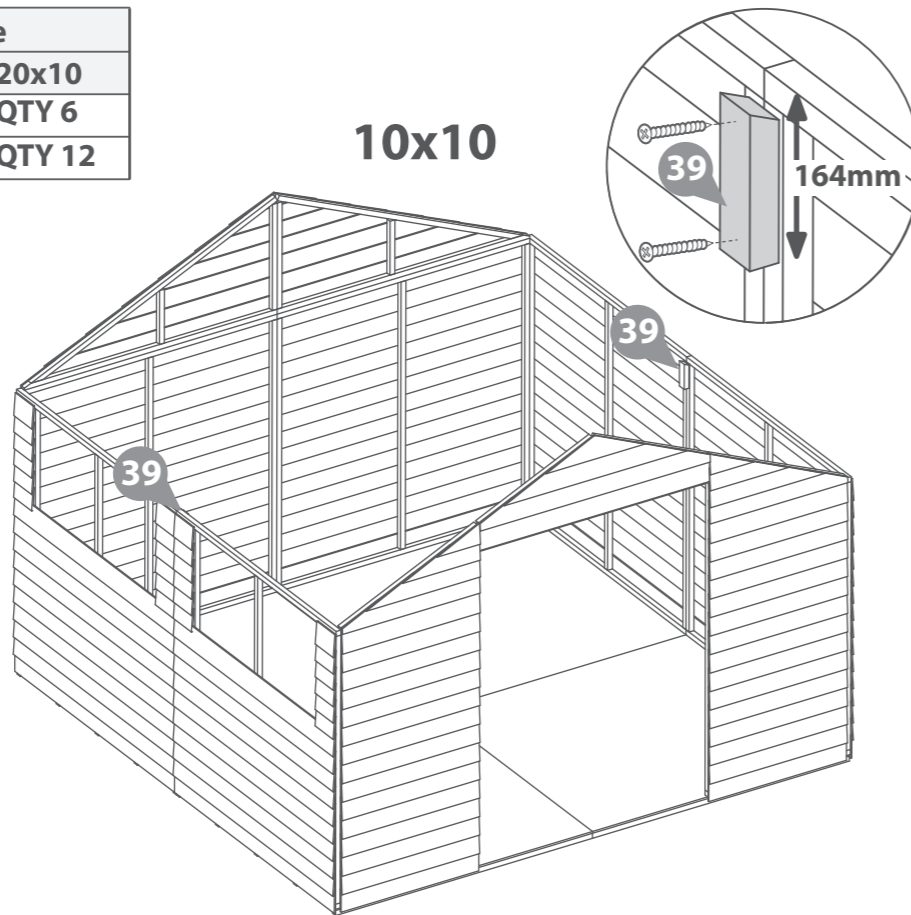

Step 14

Parts Needed	Building Size		
	10x10	15x10	20x10
No.32	QTY 1	QTY 2	QTY 3
No.37	QTY 1	QTY 2	QTY 3
50mm Screws	QTY 6	QTY 12	QTY 18

IMPORTANT: Pre-drill before fixing screws.

Locate the Truss framing (No.32) onto the truss blocks, secure using 1x50mm screw going down through the truss framing and into the truss block.

Once the truss framing is in place, locate the truss support (No.37) to the underside of the truss framing, ensuring it is flush on both sides.

***Note: there should be a 28mm gap between the truss framing at the top**

Secure the truss support using 4x50mm screws going through the support and into the framing.

Repeat for each truss assembly.

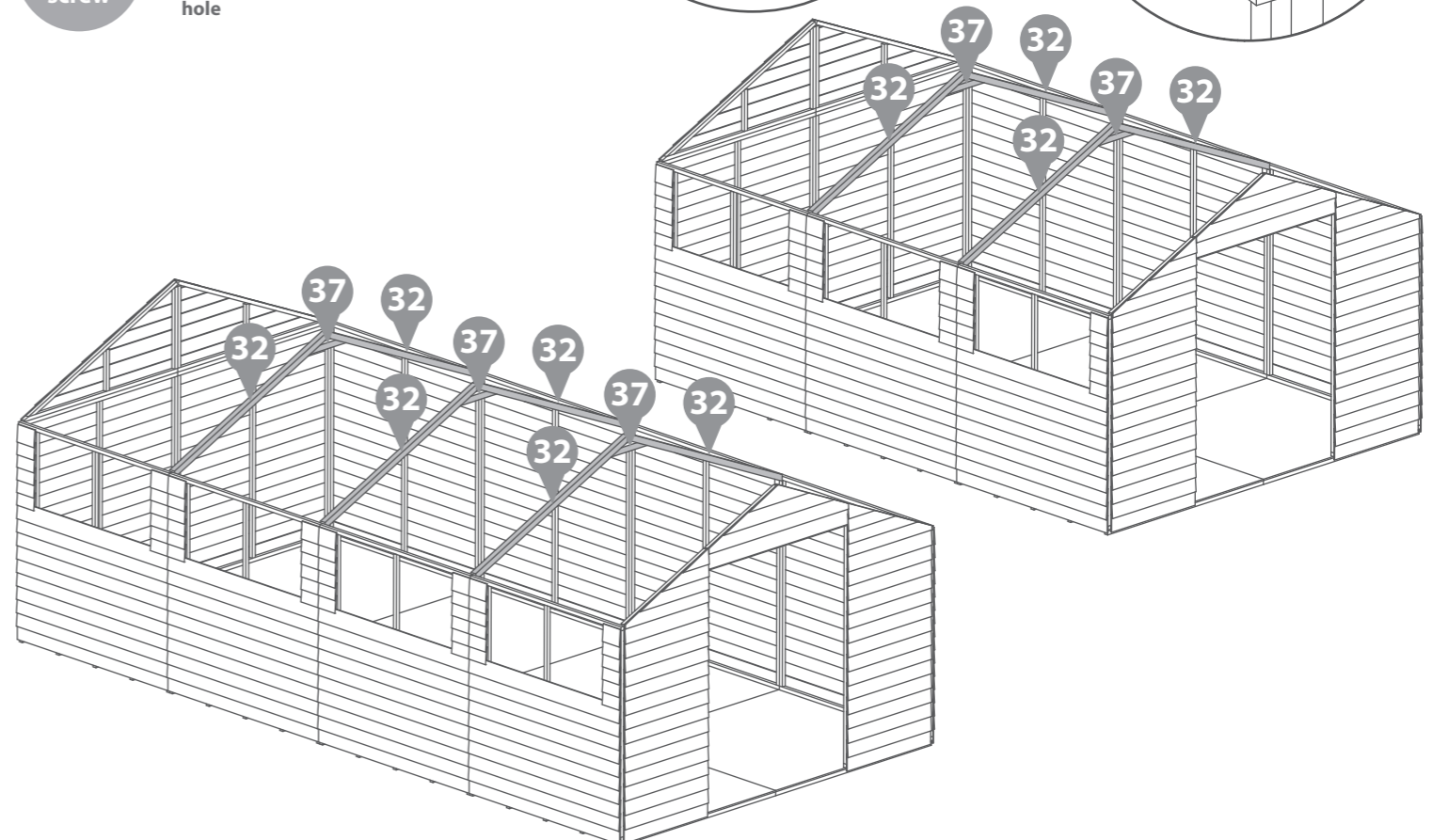
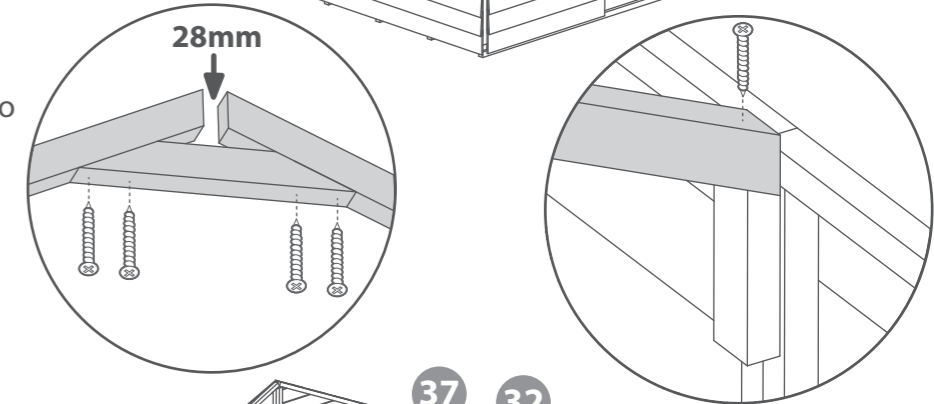
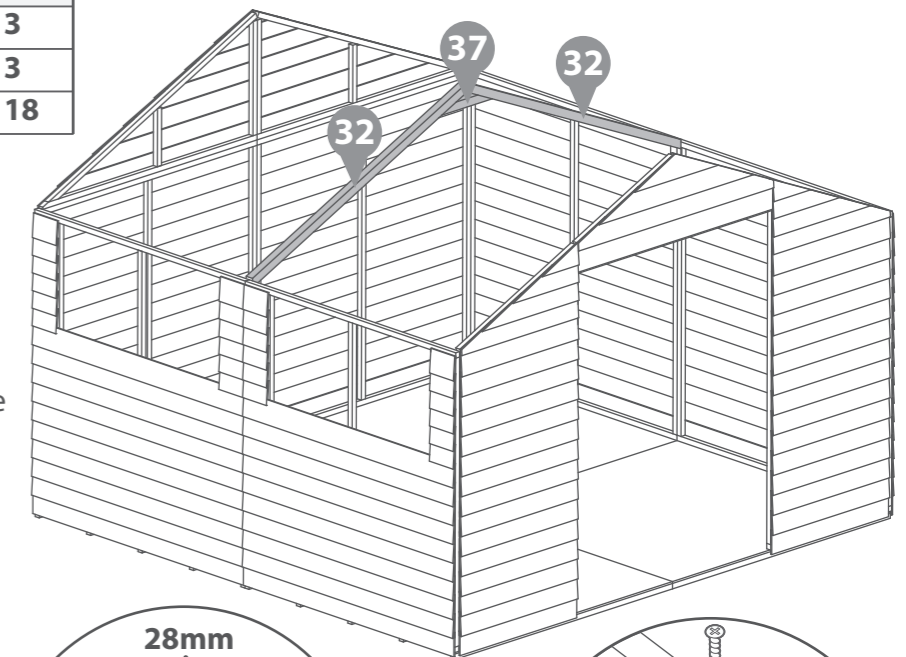
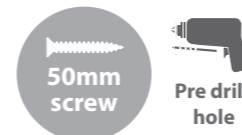

Step 15 *For 5x10 Buildings, please move onto Step 16

	Building Size		
Parts Needed			
No.21	QTY 2	QTY 2	QTY 2
No.31	QTY 2	QTY 3	QTY 4
No.34	QTY 1	QTY 2	QTY 3
30mm Screws	QTY 14	QTY 24	QTY 34

Position the two Ridge Bars (**No.31 or 41**) within the U channel (**No.11**) Secure using 10x30mm screws.

Secure a corner brace (**No.9**) to either end of the ridge bar using 2x30mm screws per brace.

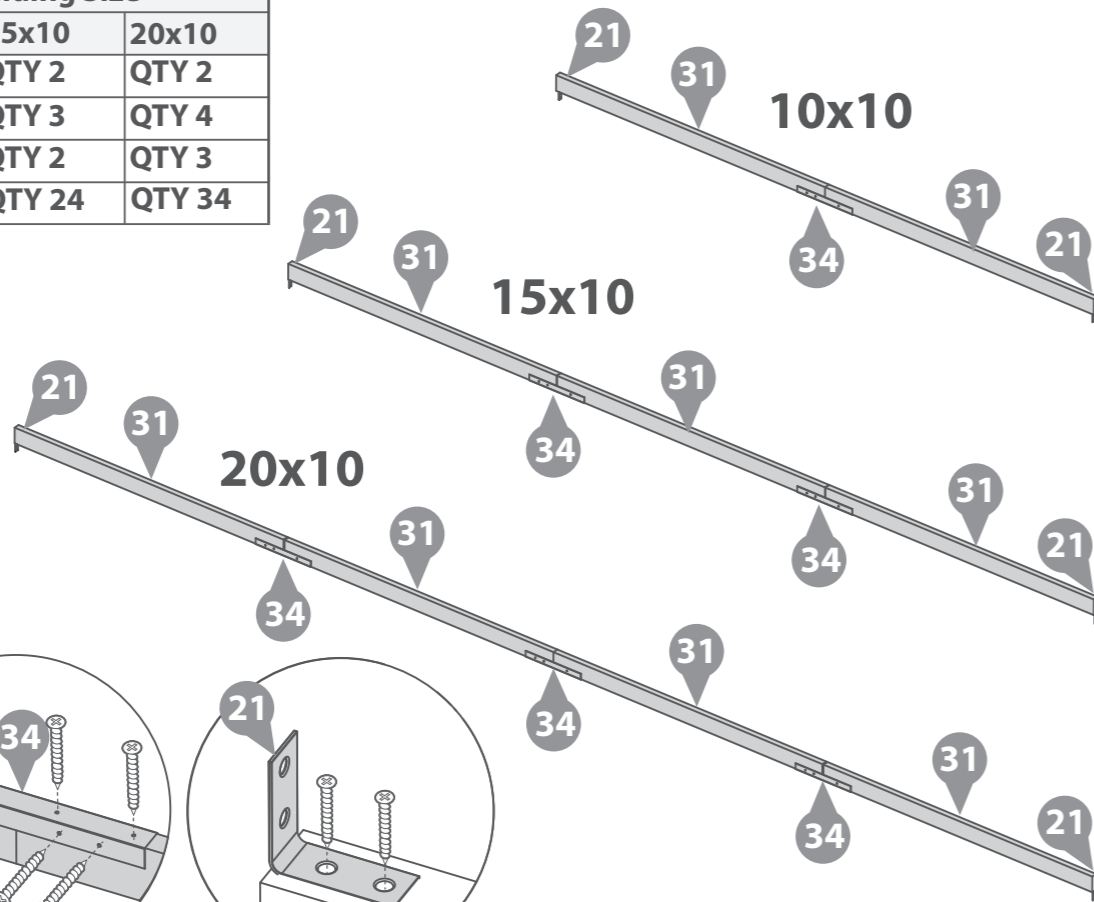
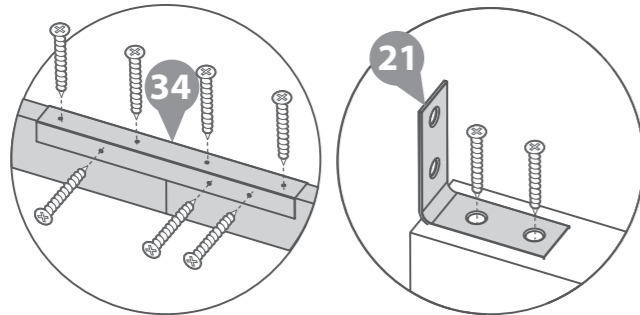
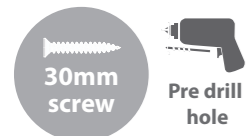

IMPORTANT: Pre-drill before fixing screws.

Step 17

	Building Size
Parts Needed	5x10 Only
30mm Screws	QTY 4

Place the assembled ridge bar in between the front and back Gables. Ensure the top corners of the support bar are flush with each top point of the Gable.

Secure the corner brace (**No. 9**) onto both the Gables framing using 2x30mm screws per corner brace.

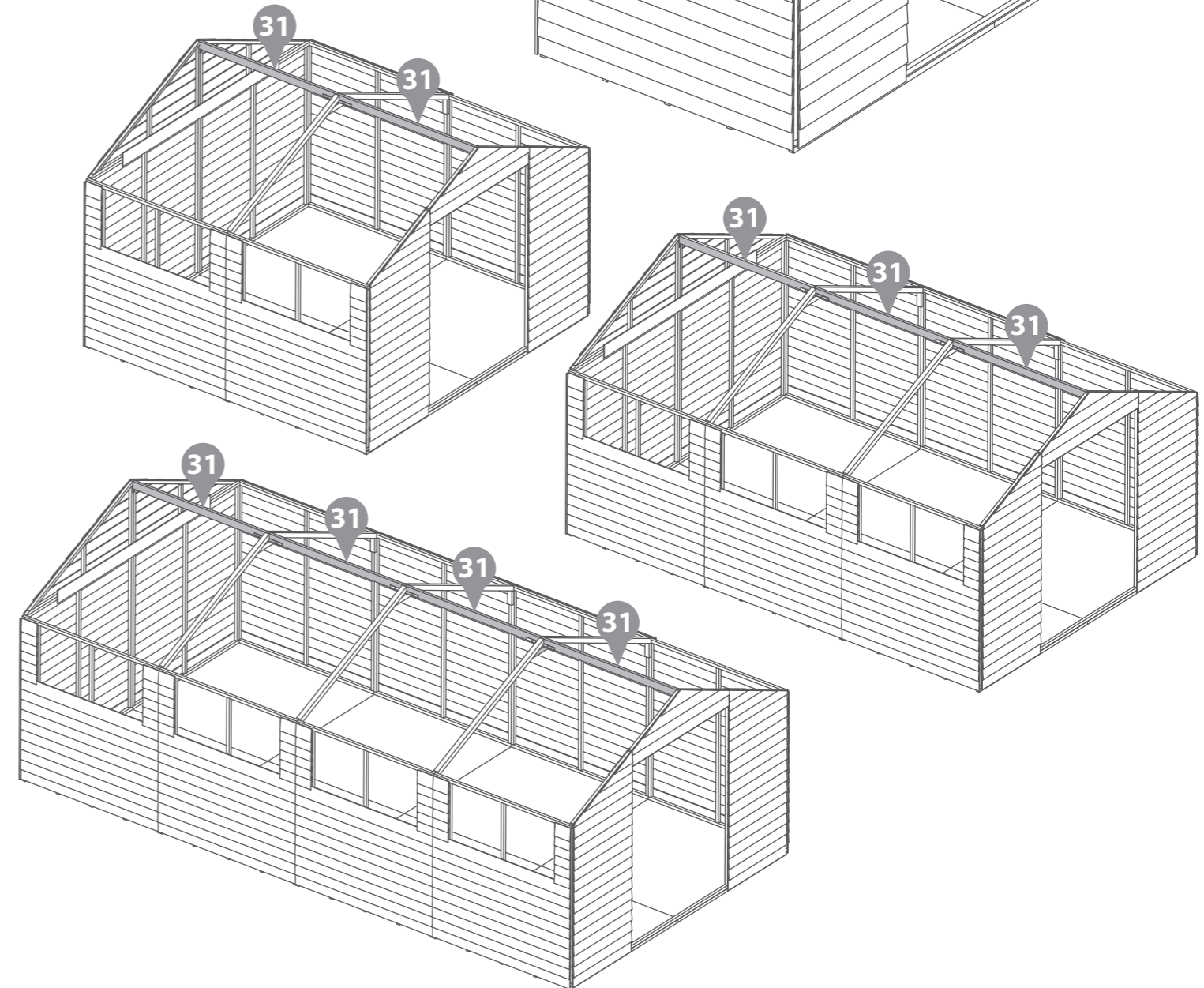

IMPORTANT: Pre-drill before fixing screws.

Step 16

	Building Size
Parts Needed	5x10 Only
No.14	QTY 2
No.21	QTY 2
30mm Screws	QTY 4

Secure a corner brace (**No.9**) to either end of the ridge bar (**No.14**) using 2x30mm screws per brace.

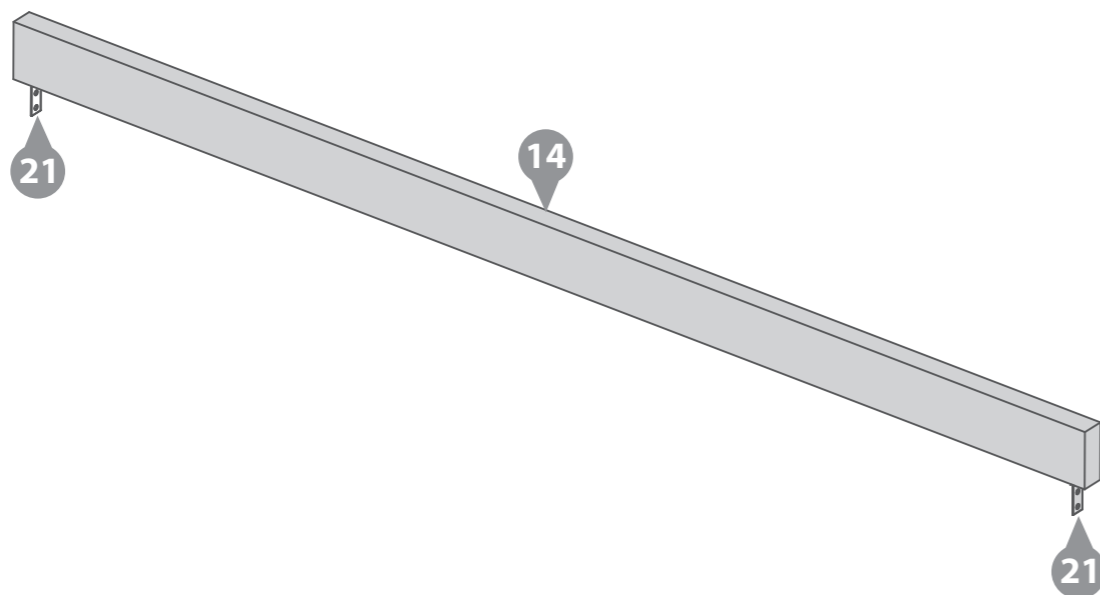
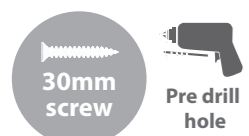

IMPORTANT: Pre-drill before fixing screws.

Step 18

Parts Needed	Building Size		
	10x10	15x10	20x10
No.30	QTY 2	QTY 4	QTY 6
50mm Screws	QTY 8	QTY 16	QTY 24

Position the truss supports (**No.30**) onto either side of the truss framing, ensuring they are flush at the top of the framing and level.

Secure using 4x50mm screws per Truss support, ensuring the screws locations are staggered to avoid collision.

Repeat for remaining Truss supports.

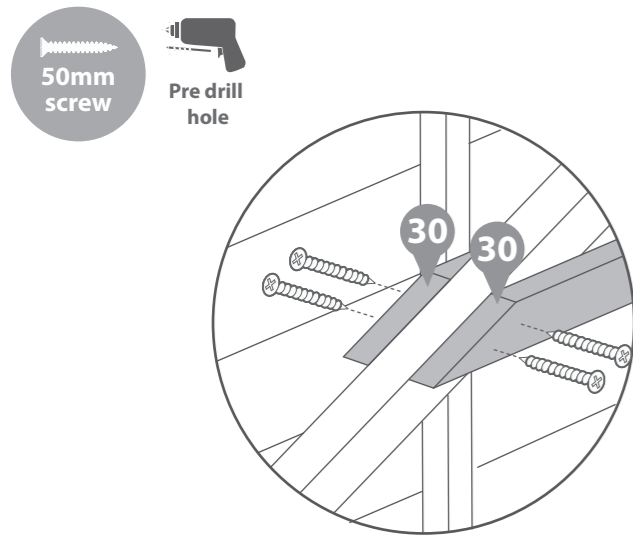

IMPORTANT: Pre-drill before fixing screws.

10x10

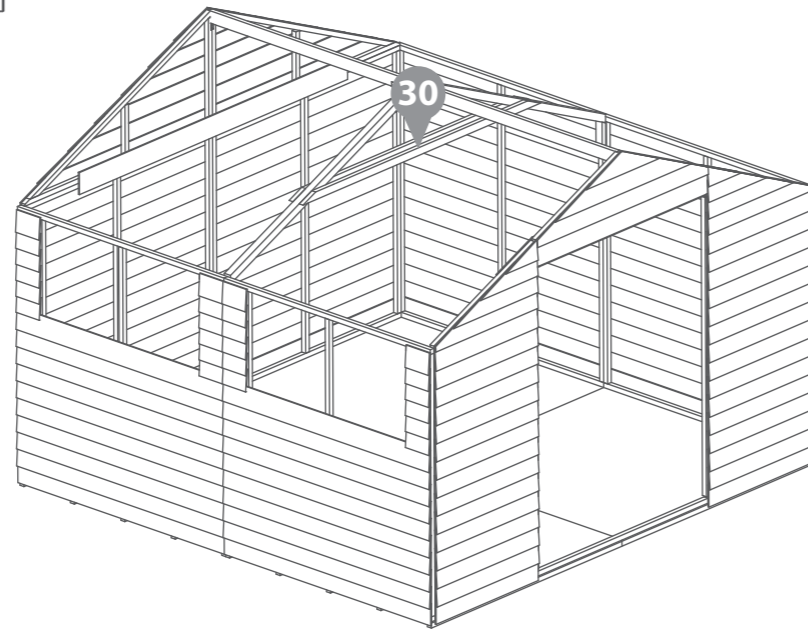

15x10

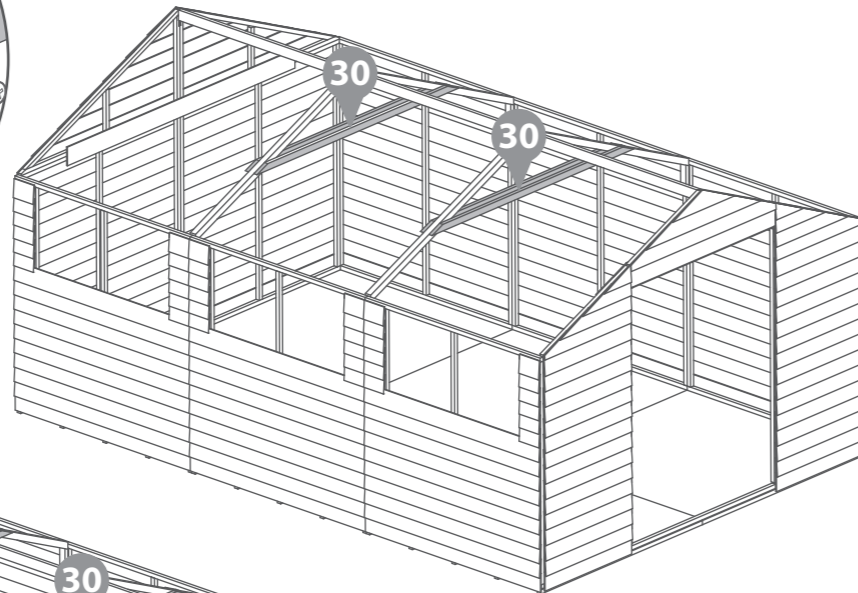

20x10

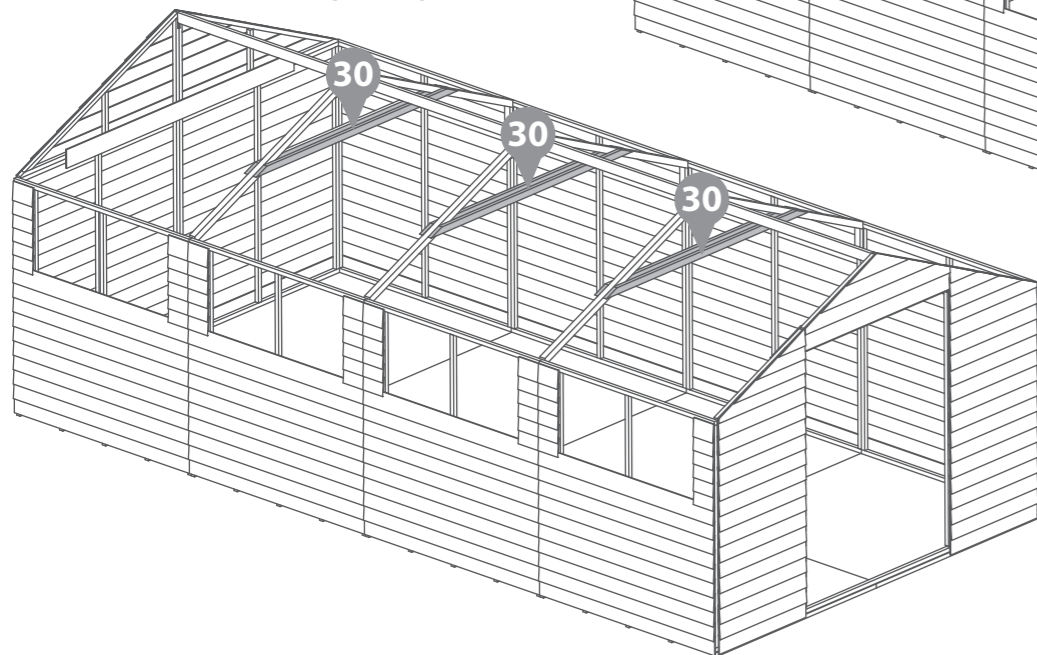

Step 19

Parts Needed	Building Size			
	5x10	10x10	15x10	20x10
No.28	QTY 2	QTY 4	QTY 6	QTY 8
No.29	QTY 2	QTY 4	QTY 6	QTY 8
30mm Screws	QTY 8	QTY 16	QTY 24	QTY 32

Place the Eaves framing (**No.29**) to the Bottom of the Roof Sheet (**No.28**), ensuring they are flush with the edge of the Roof sheet. Secure using 4x30mm screws going through the Roof sheet and into the eaves framing.

Repeat this step to create the remaining roof panel assemblies.

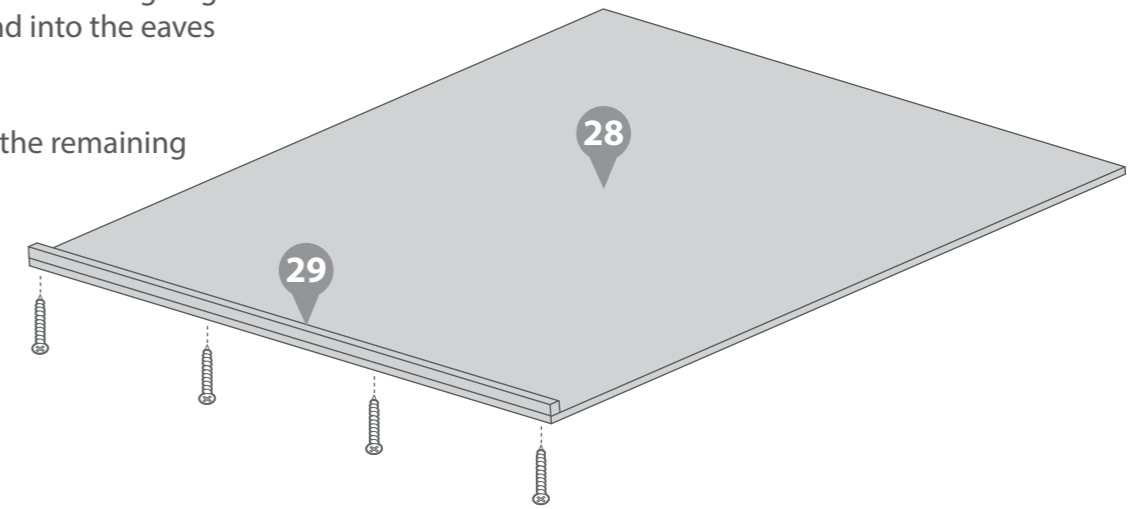

IMPORTANT: Pre-drill before fixing screws.

Step 20

Parts Needed	Building Size			
	5x10	10x10	15x10	20x10
No.28	QTY 2	QTY 4	QTY 6	QTY 8
50mm Screws	QTY 8	QTY 16	QTY 24	QTY 32

Place the Roof sheets (No.28) on top of the building. From the top, fix directly through the roof sheet and into the ridge bar below using 4x50mm screws per roof sheet.

Note: You may require another person pushing the ridge bar up from below to achieve this.

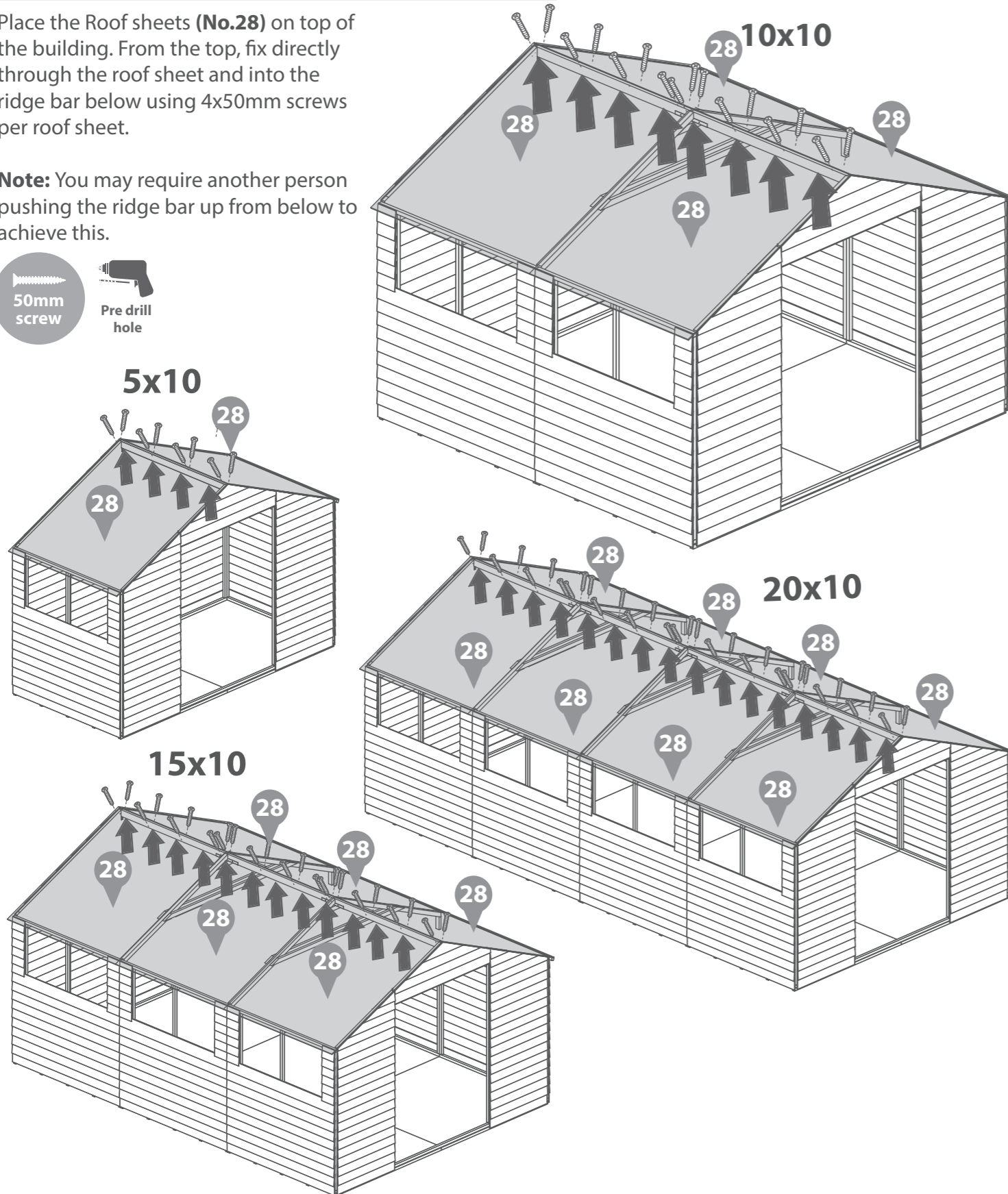
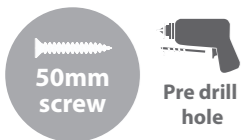

IMPORTANT: Pre-drill before fixing screws.

Step 21

***For 5x10 Buildings, please move onto Step 22** **IMPORTANT:** Pre-drill before fixing screws.

Parts Needed	Building Size			
	5x10	10x10	15x10	20x10
30mm Screws		QTY 8	QTY 16	QTY 24
40mm Screws	QTY 16	QTY 24	QTY 32	QTY 40

Fix the roof sheets to the panels using 40mm screws, ensuring to go through to the panel framing.

Fix the roof sheets to the Truss framing using 4x30mm screws per join in an alternating pattern.

***Note: for the 5x10, screw into panel framing only**

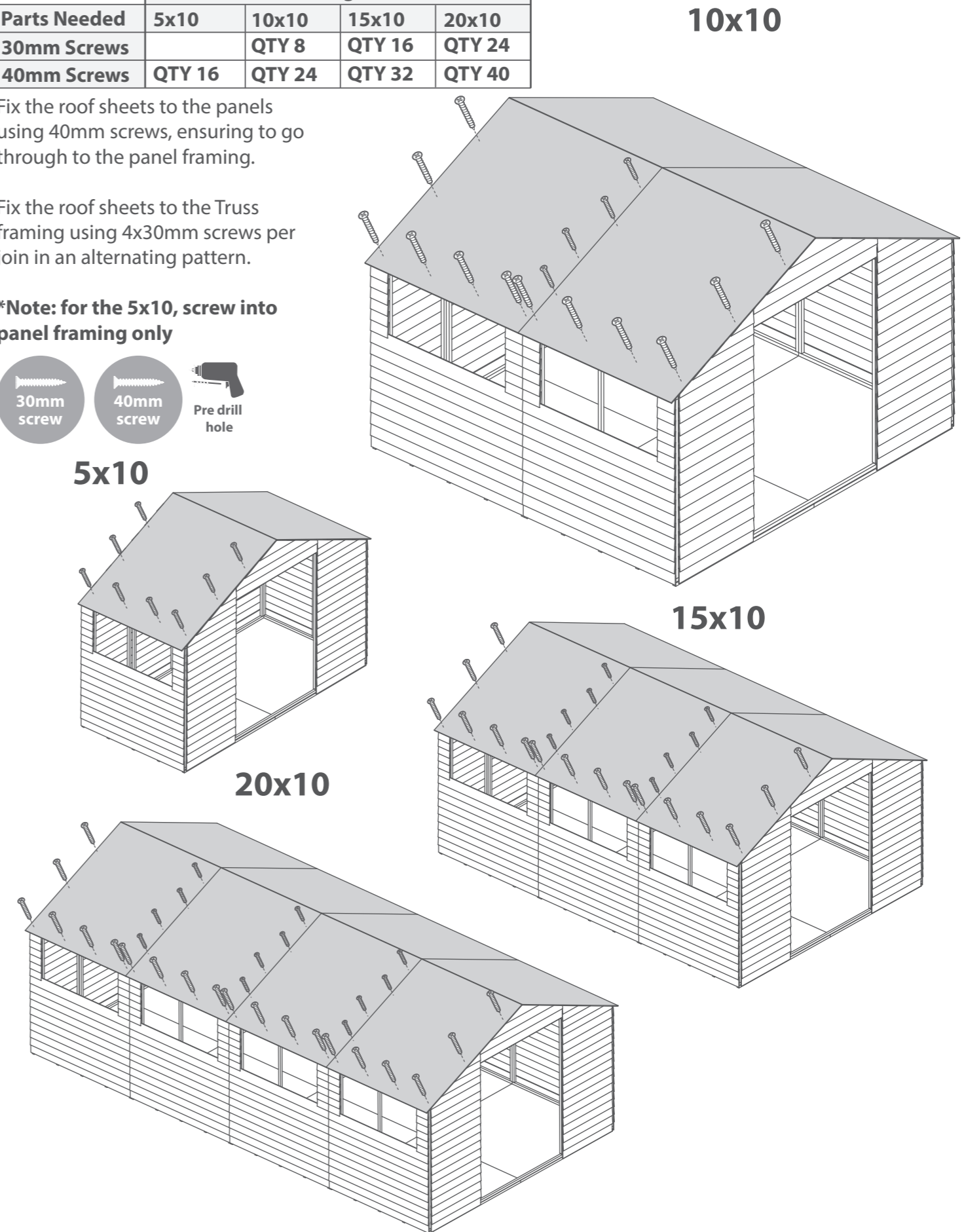
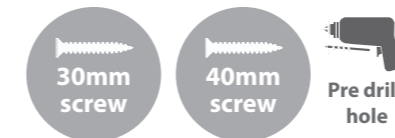

IMPORTANT : Pre-drill before fixing screws.

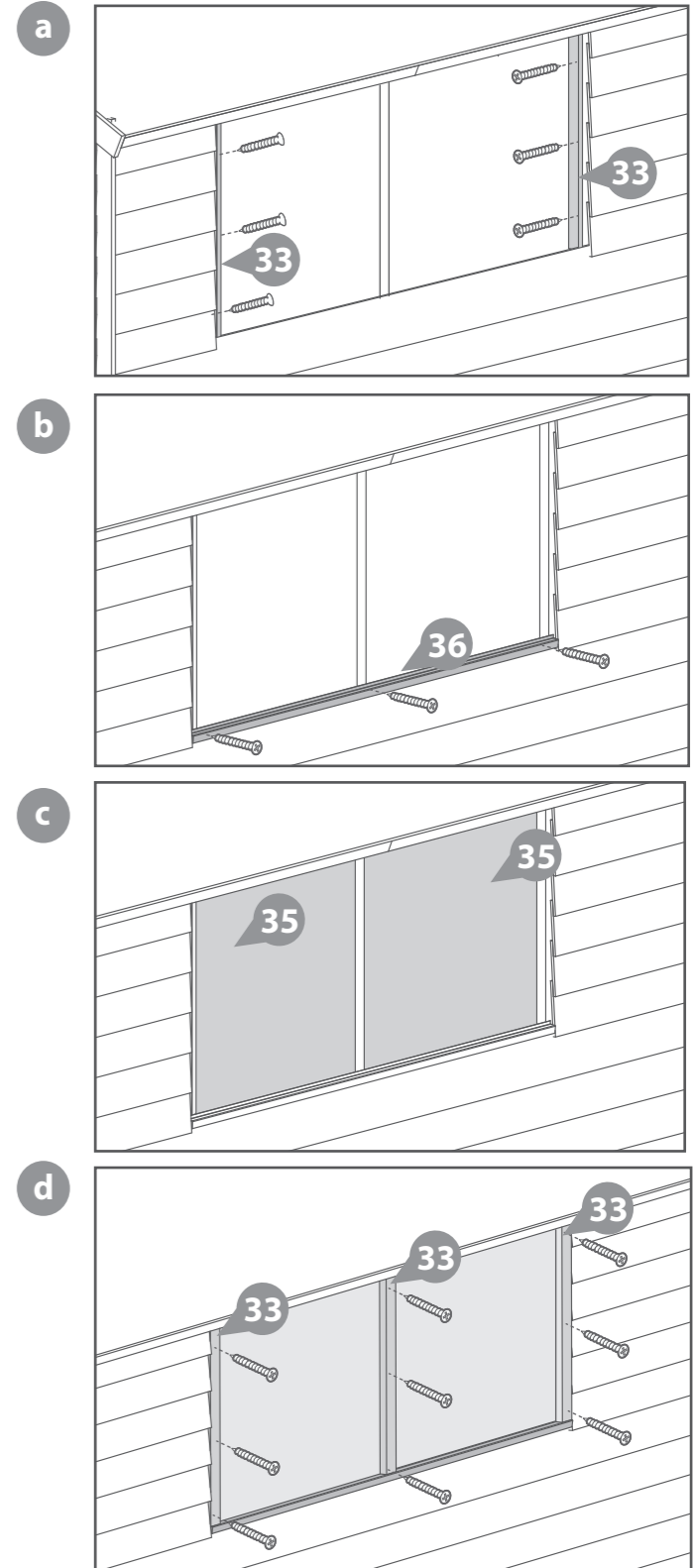

Step 23

Parts Needed	Building Size- Window Pack Only			
	5x10	10x10	15x10	20x10
No.33	QTY 5	QTY 10	QTY 15	QTY 20
No.35	QTY 2	QTY 4	QTY 6	QTY 8
No.36	QTY 1	QTY 2	QTY 3	QTY 4
30mm Screws	QTY 18	QTY 36	QTY 54	QTY 72

- a** Fix 2 window strips (No.33) to the framing that sits either side of the window, using 3x30mm screws per trim.
- b** Place the plastic window cill (No.36) onto the Window Panel as shown in the illustration Fix screws through the cill for extra support using 3x30mm screws.
- c** Fit the styrene sheets (No.35) on top of the window cill (No.36).

***For added weather protection fit your windows using silicone sealant around the outside edges.**

****When positioning the styrene sheets ensure there is an equal distance between them and either side of the windows.**

- d** Locate the Window strips (No.33) onto the Window Panel, one either side of the styrene slot in the panel and one in the centre of the two pieces of styrene, as shown in the illustration.

Fix in place using 3x30mm screws per Trim, ensuring the screws enter the framing of the window panel and not the styrene.

Repeat for remaining windows.

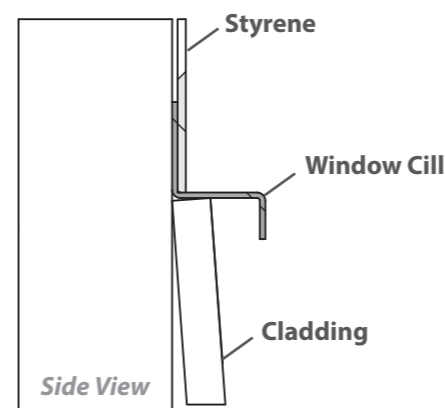

IMPORTANT: Pre-drill before fixing screws.

Step 22

Parts Needed	Building Size			
	5x10	10x10	15x10	20x10
50mm Screws	QTY 20	QTY 28	QTY 36	QTY 44

Once the roof is fully fixed, attach the panels to the floor using 50mm screws.

Ensure the screws go through the panel into the floor framing.

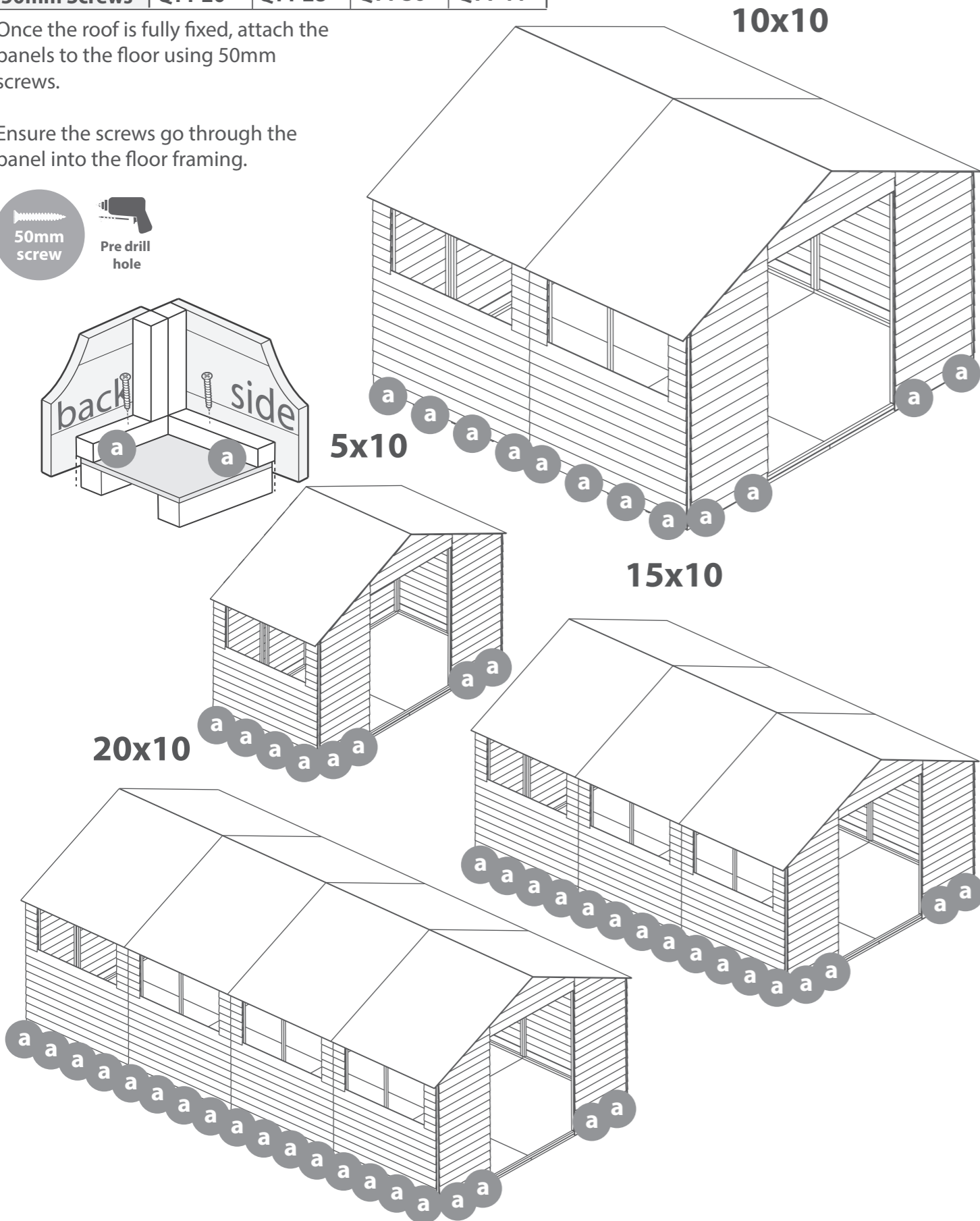
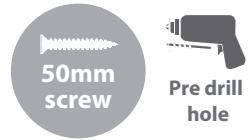

Step 24

Parts Needed	Building Size
No.5	All Sizes
No.20	QTY 2
30mm Screws	QTY 6
	QTY 42

Fix the T Hinges (**No.20**) onto the doors (**No.5**) and door gable using 4x30mm screws per hinge as shown.

Ensure that the screws go through the cladding and into the framing behind.

Fix the Doors to the front gable using 3x30mm screws per hinge.

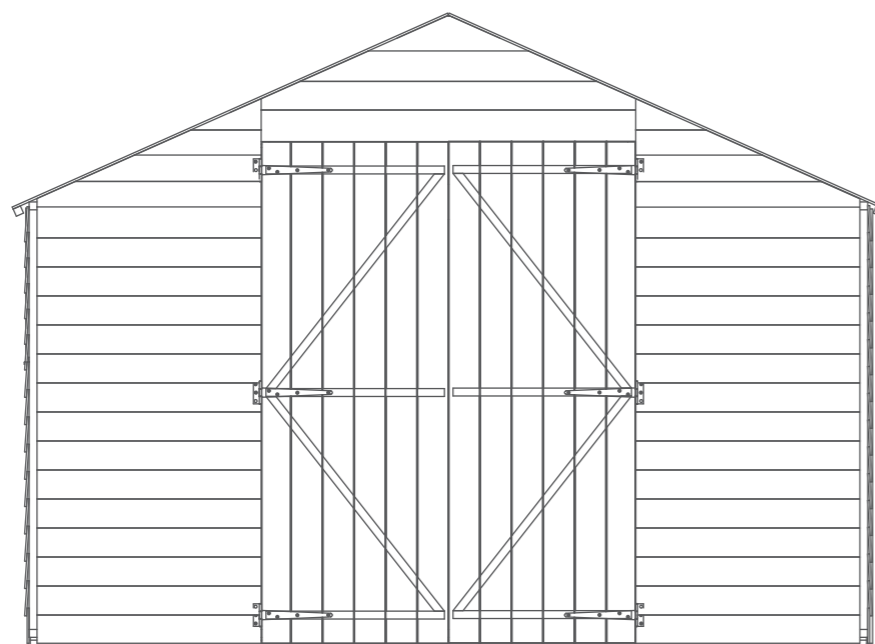
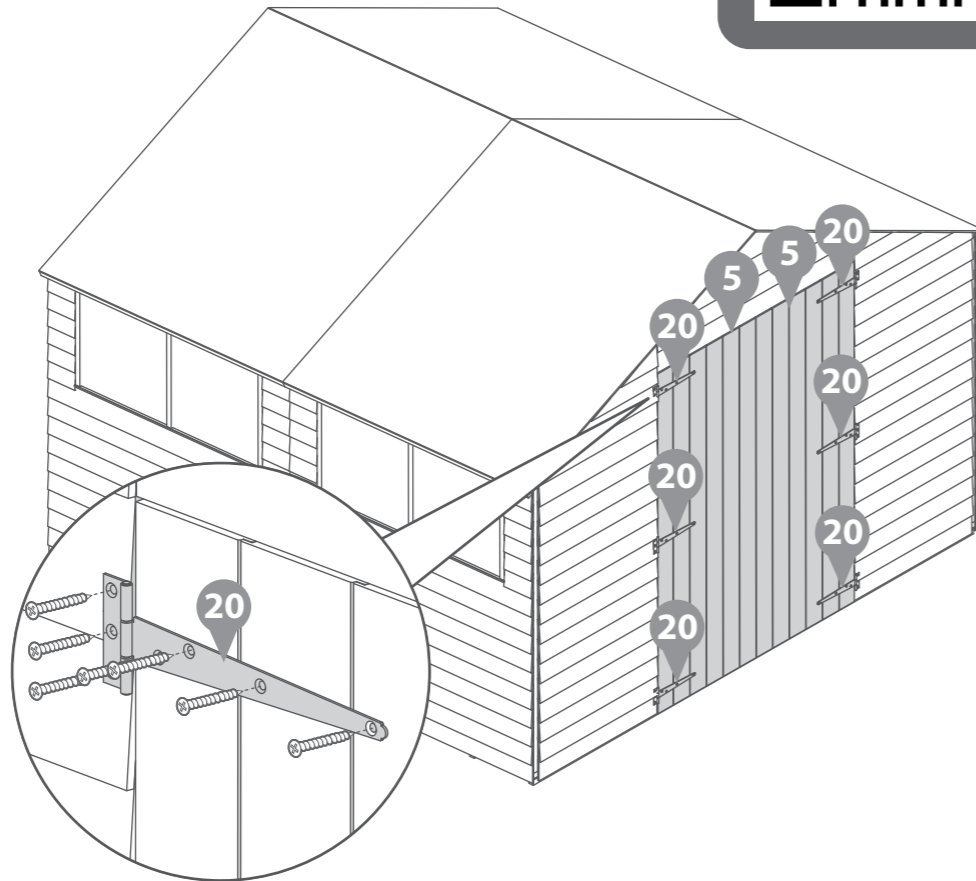

Door Framing View

IMPORTANT : Pre-drill before fixing screws.



Step 25

Parts Needed	Building Size
No.12	All Sizes
No.19	QTY 4
No.22	QTY 2
30mm Screws	QTY 18

Place the door blocks (**No.12**) on top of the internal framing on the top and bottom of the doors and align the ends to the centre.

Fix with 2x30mm screws per block by screwing through the matchboard door into the block.

Locate the Door Beading Strip (**No.19**) into the gaps on either side of the doors, between the gables and door.

Fix in place using 4x30mm screws per strip. Ensure that the screw is parallel with the door frame when fixing the strip to the gables as shown in the illustration.

Attach one turn button (**No.22**) to the top and bottom door blocks with 1x30mm screw per turn button.

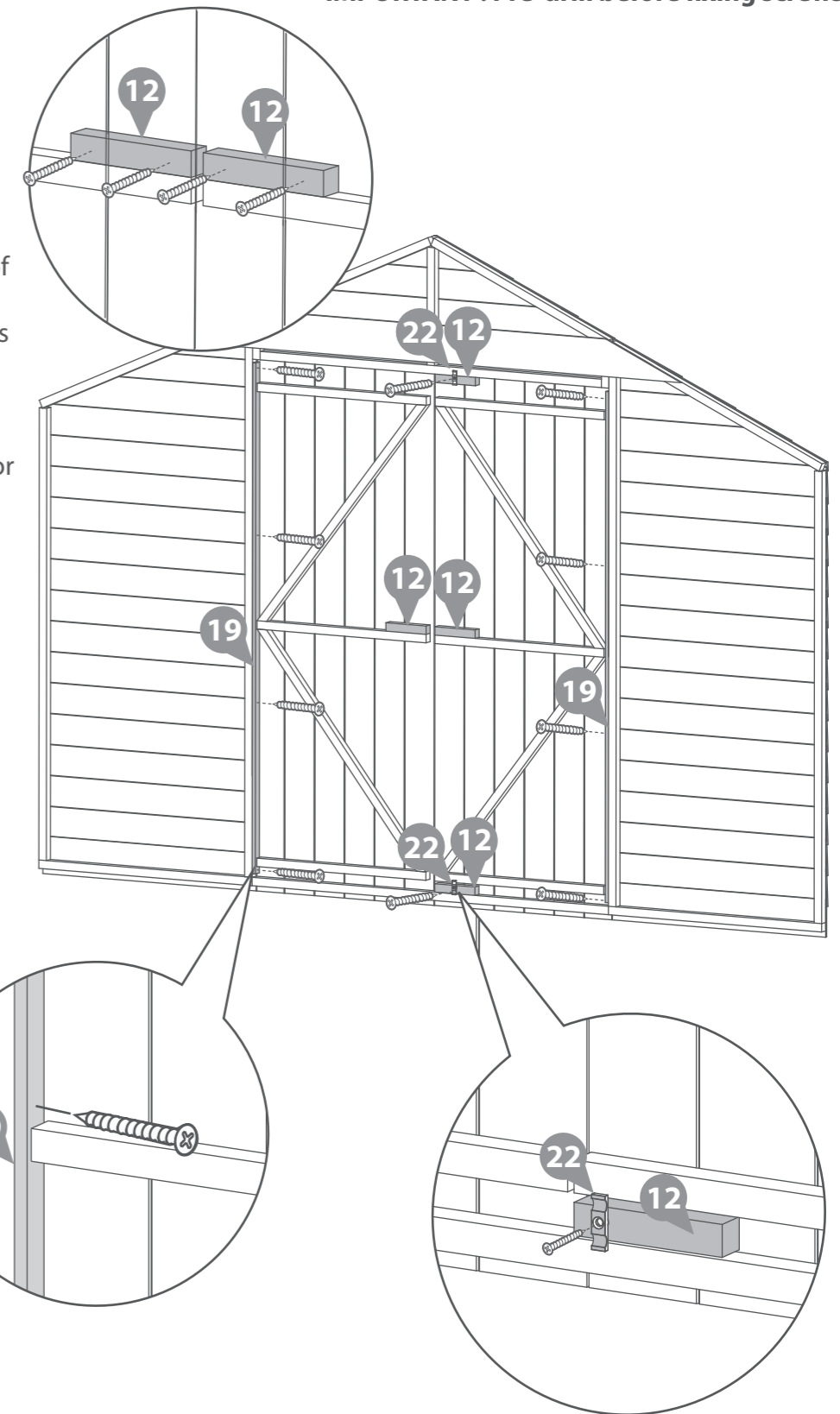

IMPORTANT : Pre-drill before fixing screws.

Step 26

	Building Size			
Parts Needed	5x10	10x10	15x10	20x10
No.25-Size Required	1570mm	3050mm	4520mm	5990mm
Felt Tacks	QTY 75	QTY 150	QTY 225	QTY 300

Cut four strips of felt (No.25) to the dimensions stated for your building size and place onto the roof. Place the felt flat onto the roof in the order that is stated on the diagram below.

***Ensure there is approximately 50mm of overhang on each side.**

Once the sheets are laid out, fix them onto the roof with felt tacks spaced 100mm apart.

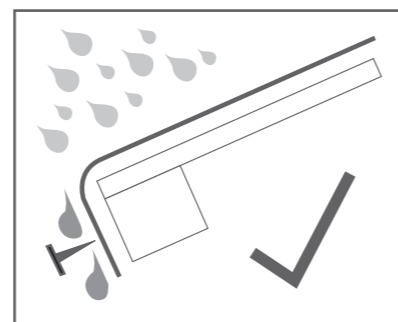
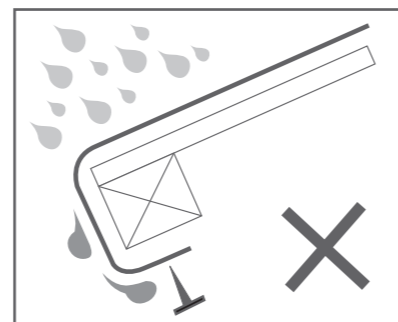
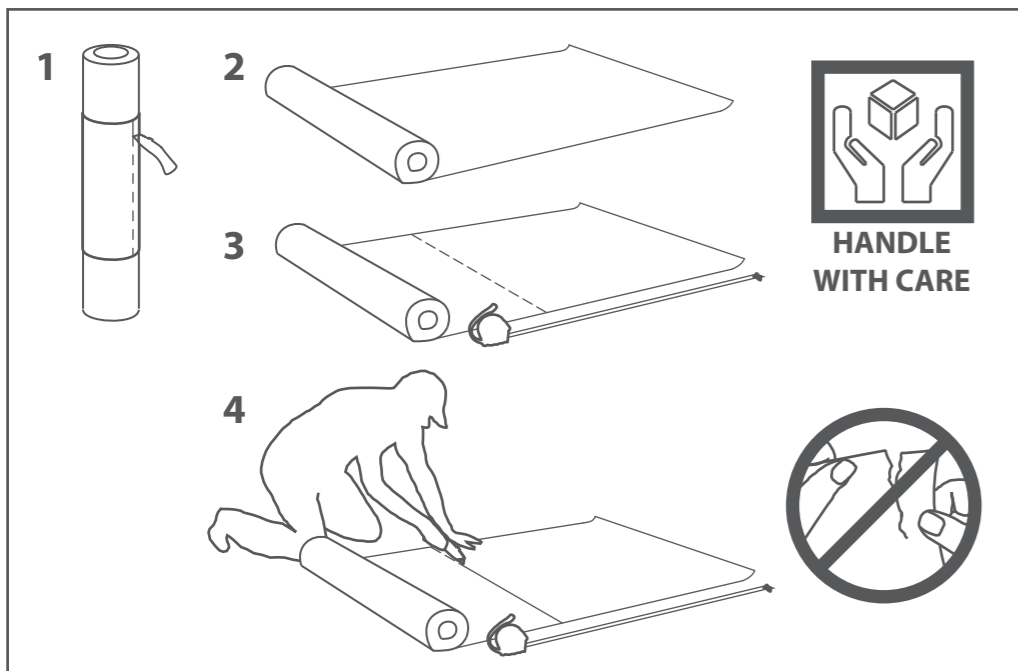
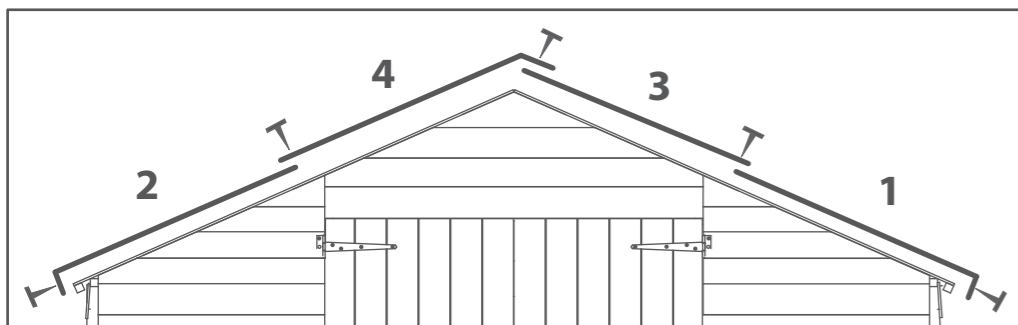
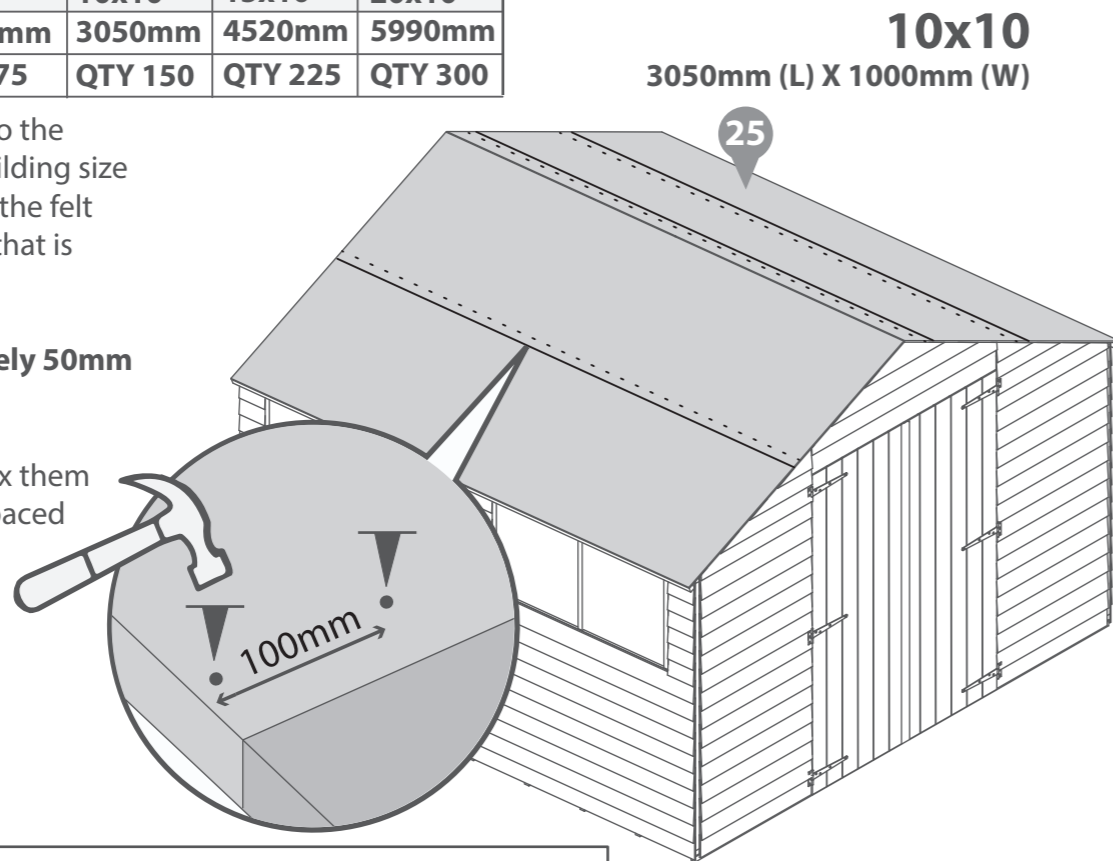

5x10
1570mm (L) X 1000mm (W)

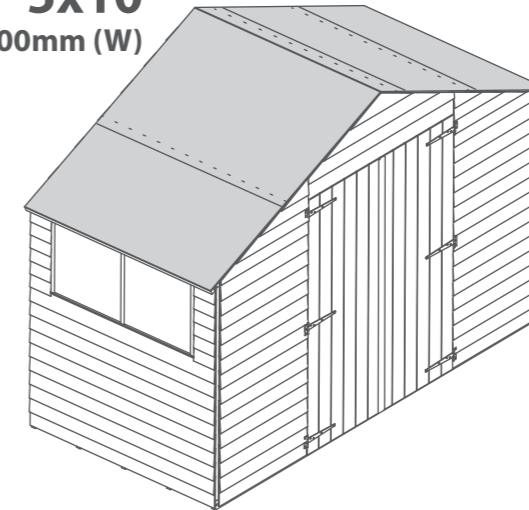

15x10
4520mm (L) X 1000mm (W)

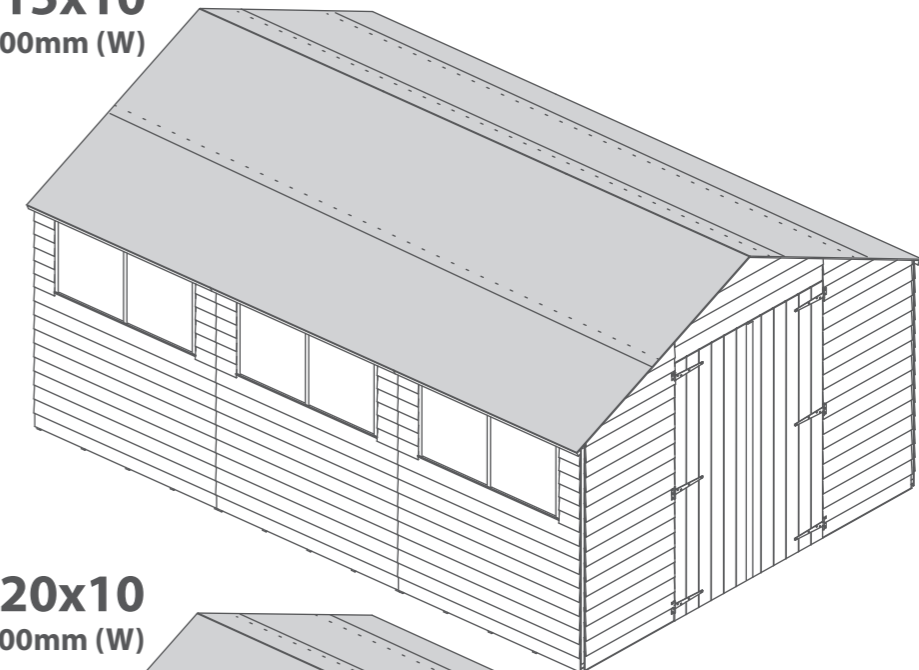

20x10
5990mm (L) X 1000mm (W)

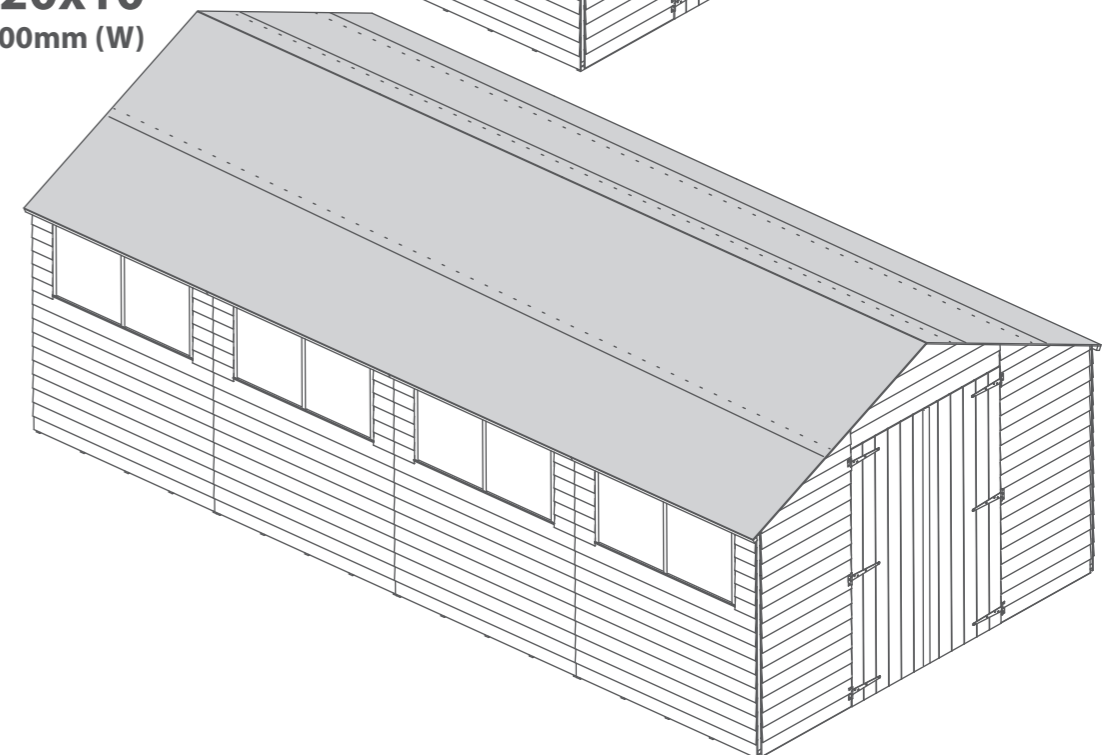

Step 27

Parts Needed	Building Size
No.9	All Sizes
No.10	All Sizes
No.24	All Sizes
20mm Screws	All Sizes
30mm Screws	All Sizes

Locate the Door cover strips (**No.9** and **No.10**) onto the two doors, the longer strip (**No.9**) at the bottom, ensuring it is flush with the bottom of the doors, and the shorter strip (**No.10**) at the top, ensuring it is flush to the top of the doors.

Fix the strips to one door (the right hand door) using 20mm screws.

Fix the Hasp and Staple (**No.24**) to the door using 7x30mm screws, ensuring to go through the door cladding and into the door blocks.

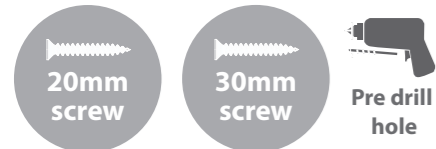
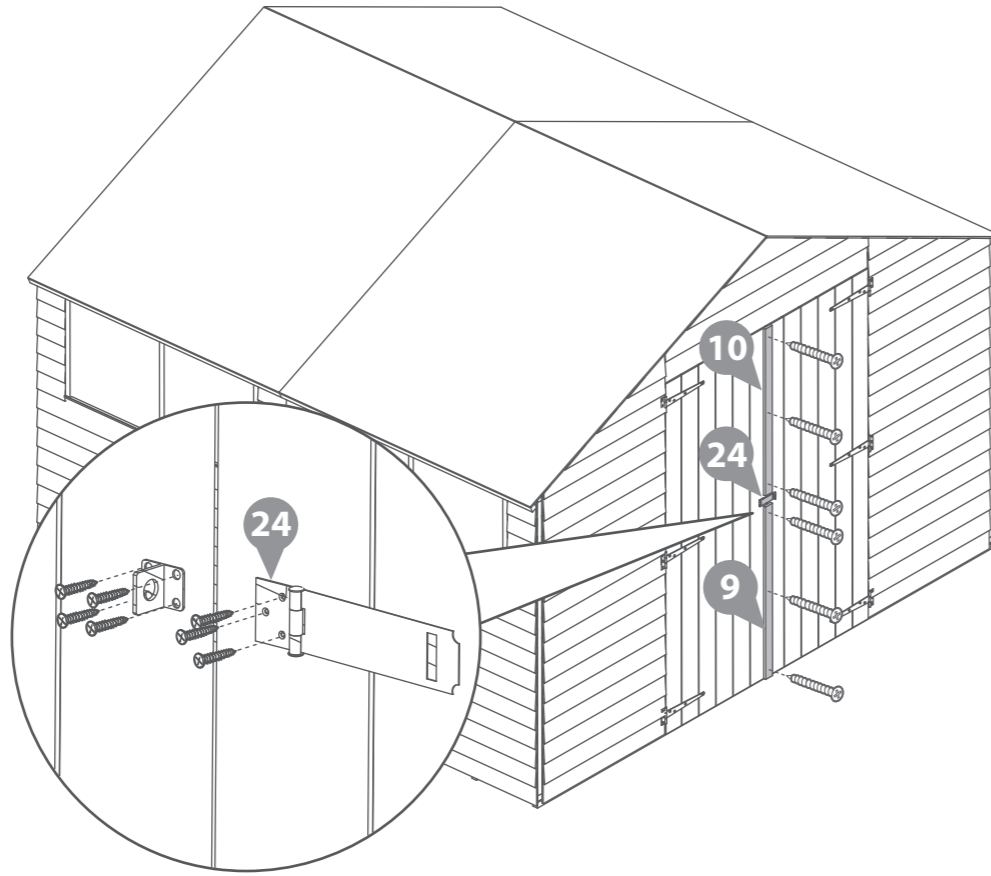

Step 28

Parts Needed	Building Size			
No.16	5x10	10x10	15x10	20x10
30mm Screws	QTY 5	QTY 7	QTY 9	QTY 11
	QTY 15	QTY 21	QTY 27	QTY 33

Place the panel cover trims (**No.20**) onto each corner and panel join of the building, secure using 3x30mm screws per cover trim.

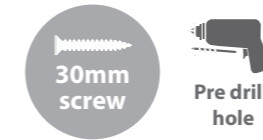

IMPORTANT : Pre-drill before fixing screws.

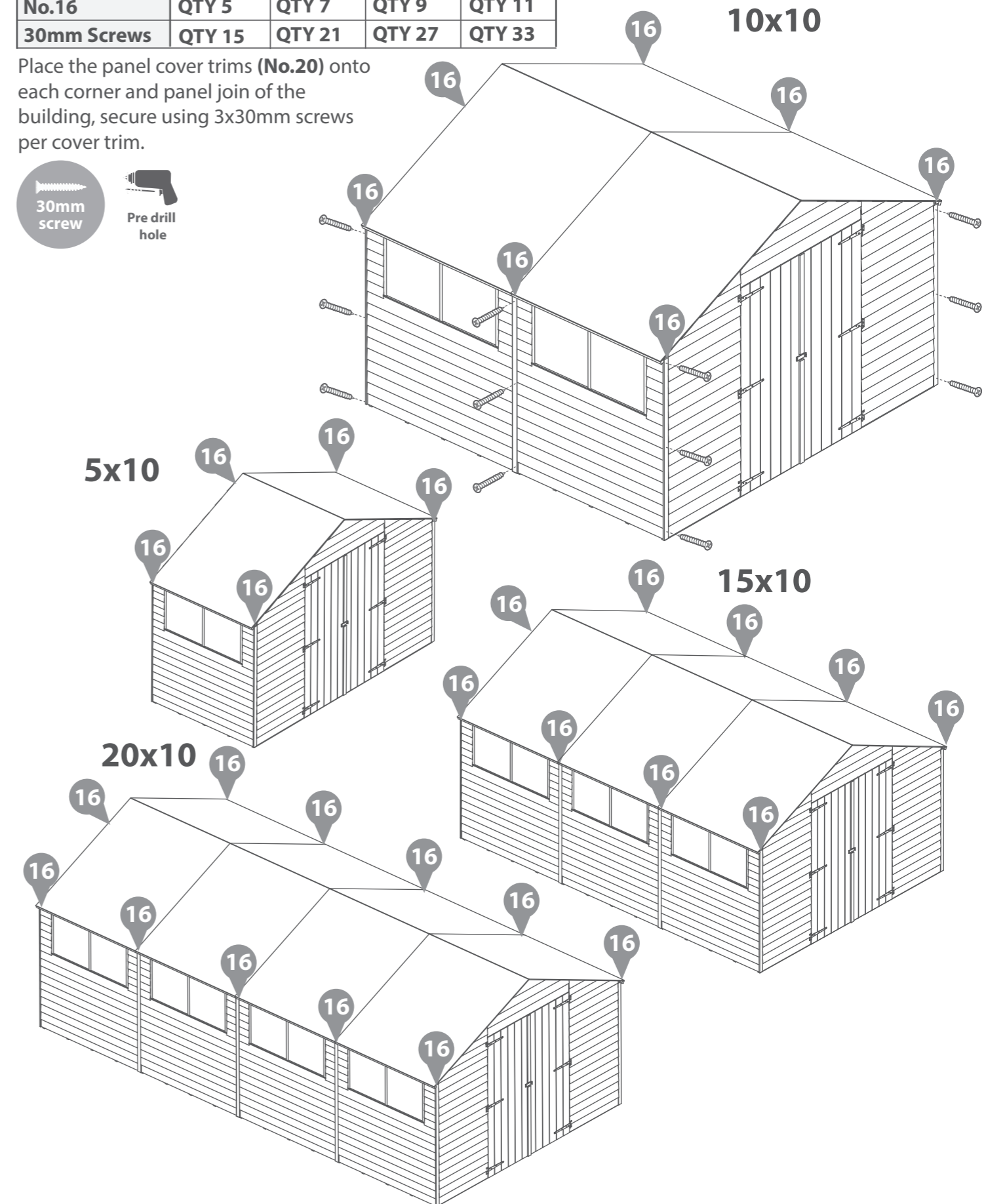

Step 29

Parts Needed	Building Size
No.11	All Sizes
30mm Screws	QTY 3

Locate the Back cover trim (No.11) on the back of the building. Secure in place using 3x30mm screws.

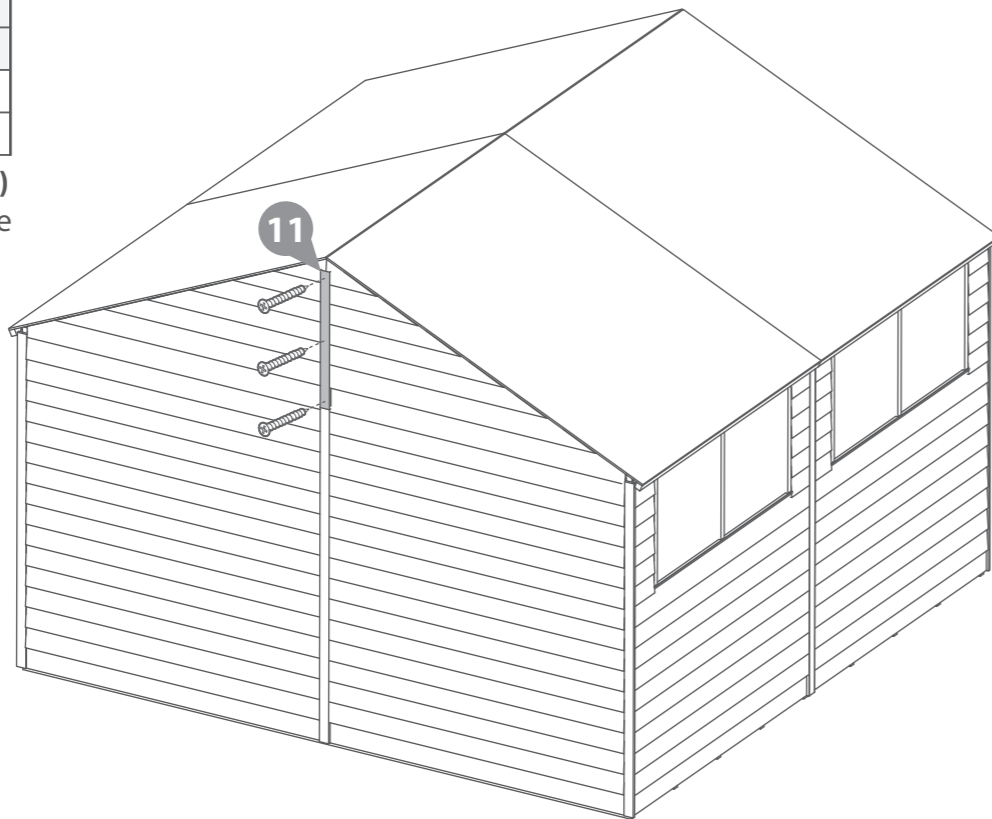
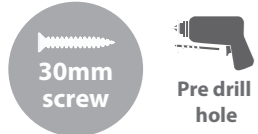

IMPORTANT : Pre-drill before fixing screws.

Step 31

Parts Needed	Building Size
No.15	All Sizes
No.23	QTY 2
40mm Screws	QTY 16

Fit the fascias (No.15) to the roof over the felt and secure into place with 40mm screws as shown. Pre-drill to avoid splitting.

Followed by adding the Finials (No.23) over the fascias using 2x40mm screws per finial.

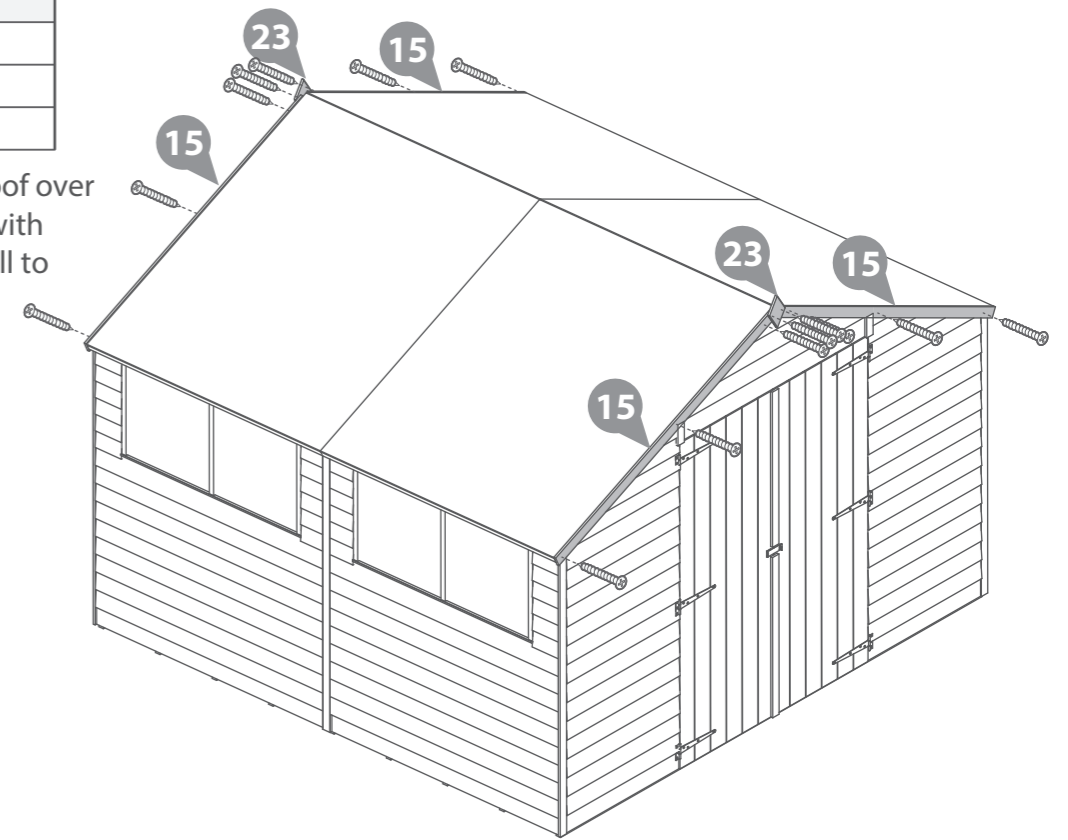

IMPORTANT : Pre-drill before fixing screws.

Step 30

Parts Needed	Building Size
No.8	All Sizes
30mm Screws	QTY 4

Fit the Front panel Cover strip (No.8) onto the front gable, so they cover where the panels join together. Secure in place using 2x30mm screws per cover trim.

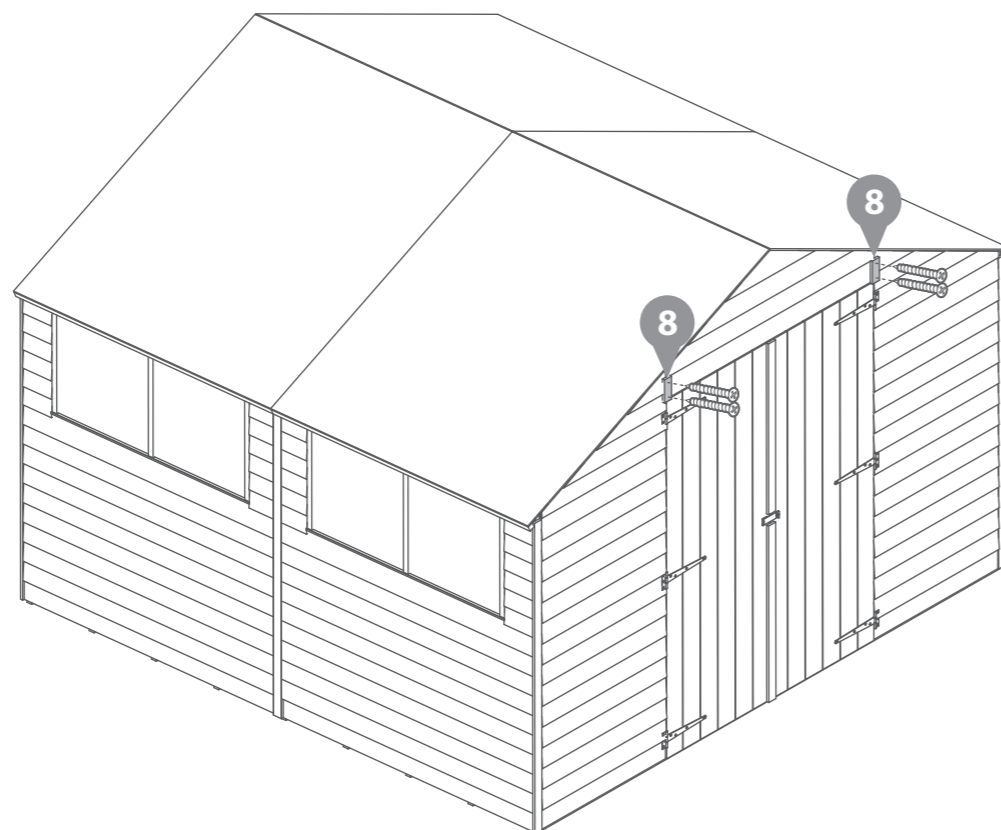
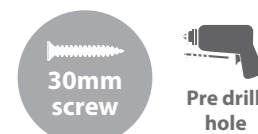

IMPORTANT : Pre-drill before fixing screws.

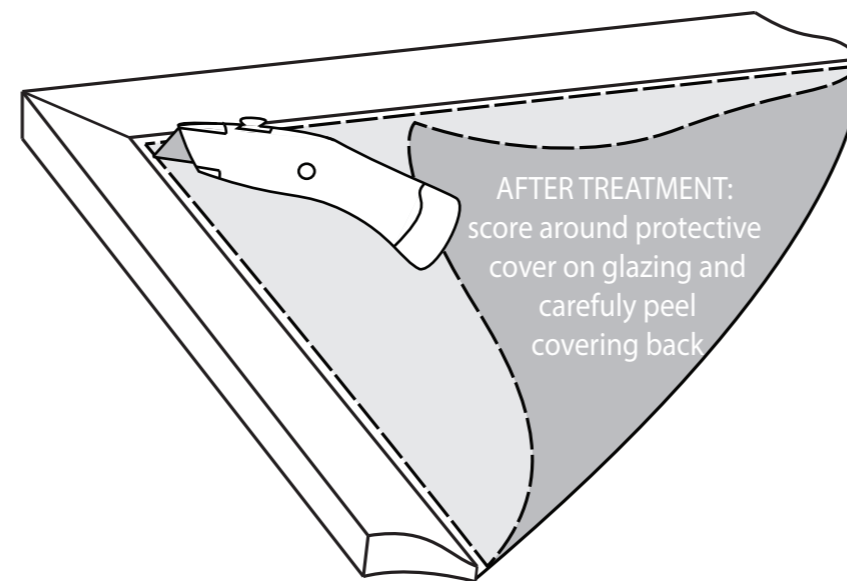

LEAVE US A REVIEW...

Want to share your experience with us?
Leave us a review on Feefo, TrustPilot or Google.

Your reviews help other people find and trust our business, as well as helping to play an important role in our growth and improvement!

TREATING YOUR GARDEN BUILDING

Preservation of wood that's outdoors is vital. A little early care will help protect your garden building, improve its appearance and ensure maximum longevity. Insects, moisture, salt, and changing weather can have dramatic effects on the stability and appearance of your garden building. Once your building is installed, you've checked it over and you're happy with it, you can take a few basic precautions to prepare it for the elements. Treating your garden building helps prevent decay and, by repelling water, discourages the growth of moulds and fungi that could jeopardise the structural integrity of the wood.

Dip Treated buildings - Require a preservative treatment to protect against rot and decay and a waterproof treatment to prevent water ingress
Pressure Treated buildings - Require a waterproof treatment to prevent water ingress
Log Cabins/Insulated Garden Rooms - Are supplied untreated and require a preservative and waterproofing treatment.



ANY QUESTIONS?
Scan the QR code to contact us via our customer portal.

To apply a preservative and water proofing treatment (pressure treated products do not require a preserver), follow the manufacturer's instructions but in principle, stick to the following steps:

- ✓ Wear latex or rubber gloves, eye protection and (if spraying) a mask.
- ✓ Prepare the wood, by sanding down any ridges or inconsistencies in the wood, smoothing out knots and end-cuts.
- ✓ Choose a dry day to treat your garden building. If you're spraying rather than brushing paint on, avoid a windy day.
- ✓ Be sure you can safely reach all the sections you need to paint - and if you need a ladder, make sure it's safely positioned before climbing. Lay dust sheets around to avoid paint splatters on your base or surrounding plants.

- ✓ Tape around windowpanes to avoid smears when you're painting the frames.
- ✓ Keep pets and small children out of the way. The last thing you want is to have fur on your garden building paint, or little painted footprints all over your garden and home.
- ✓ Fill any gaps in the building's body with caulk or wood filler to prevent water and draughts getting in. Silicone based caulk is flexible and will move with the timber when temperature and humidity change. Allow to dry completely before treating. A handy tip for finding gaps is to go into your garden building and look for light leaking through joins and frames. If light gets in, then so will water.
- ✓ Liberally apply at least two coats of the treatment products with a brush or spray, taking care to allow the first coat to completely dry before applying the second.
- ✓ Make sure the solution permeates the whole of the surface area, especially around natural cracks, end cuts and nail/screw holes.



APPLY WOOD TREATMENT
IMMEDIATELY
AFTER ASSEMBLY

PLEASE SCAN HERE TO
SEE TREATMENT VIDEO:



1 Perimeter

Check around the perimeter of your product to ensure there are not trees or plants that are in contact with or overhanging the building. This can affect airflow and overhanging trees, or branches can damage the roof, it is advised to keep plants at a distance.

2 Repair

Inspect the interior and exterior of the product to look for splits, cracks, and holes. Although this is a natural occurrence it can be prevented. A wood filler can be used to close the splits, cracks, and holes.

3 Roof

Check your roof regularly for tears, splits, damaged wood and fallen debris. If you notice any of this immediate repair is critical.

4 Doors & Windows

Expansion and contraction can cause doors and windows to stick or become difficult to open. Small adjustments to the hinge position can be made to the doors and windows to allow free movement.

5 Oil

Hinges can seize up over time, apply lubricant to the hinges and locks annually.

6 Screws & Bolts

It is advised to check all screws and bolts and tighten any loose you might find. For log cabins specifically the storm braces will require loosening. During humidity and temperature changes (seasons) to allow expansion and contraction to prevent gaping, twisting, popping, and warping.

7 Wash

At least once a year, give the outside of you building a good wash, to remove cobwebs, leaves, or any other dirt that may accumulate on the exterior.

8 Airing

Airing your product regularly prevents the build up of condensation which can cause the timber to rot and mould. Condensation can build up over time or daily, it is caused by a rise and fall in temperature. Leaving doors and windows open regularly can help combat the natural moisture build up.

9 Clean & Tidy

It is good practice to clean the inside and outside of your product regularly. Clear out the contents, sweep the floor, remove dirt and cobwebs. Check for areas of damp and investigate the cause to remove and prevent future occurrences. Check the ground around your product for build up of debris such as leaves, remove and ensure there is clear ventilation underneath the floor.

Additional Playhouse Maintenance:

It is recommended that the following checks and maintenance are carried out at the beginning of each season as well as at regular intervals during the usage season.

- Check all nuts /bolts/ screws for tightness and tighten when required.
- Check for movement / opening of wood giving rise to protrusion of nail heads and tips.
- Check hinges.
- Replace defective parts in accordance with the manufacturers instructions.
- Check any crossbeams, suspensions and anchors.
- If a swing is included; check the swing seat, chains and ropes.

IF THESE CHECKS ARE NOT CARRIED OUT THE ACTIVITY TOY COULD BECOME A HAZARD

All our garden buildings have been designed and manufactured with care and attention to be the perfect addition to your outdoor space. To ensure you do get the best out of your new garden building and to increase the longevity we advise that you follow the product instructions and our manufacturer's recommendations as detailed below. Thank you for choosing a Mercia Garden product!

1 Choosing the most suitable location for your garden building...

A minimum of 60cm should be left around the perimeter of your garden building to allow access for maintenance, annual treatment and to allow air flow around the building.

Where possible you should avoid placing your garden building underneath large trees to prevent the tree causing damage to the building.

2 Preparing the base for your garden building...

All our buildings must be built on a firm, level base to ensure the longevity of the building and prevent the wood from distorting. We recommend either concrete, concrete slabs or a wooden base, such as our 'Portabase'.

The base should be slightly smaller than the external measurement of the building, i.e. the cladding should overlap the base, creating a run off for water and preventing water from pooling underneath the building.

We also recommend that the floor of the garden building is a minimum of 25mm above the surrounding ground level to avoid flooding.

3 After installation...

Once your garden building has been installed, it will need to be treated within 14 days (weather permitting) and annually to prevent the timber from deteriorating and to waterproof it. This is required to maintain the anti-rot guarantee.

Dip Treated buildings - Require a preservative treatment to protect against rot and decay and a waterproof treatment to prevent water ingress.

Pressure Treated buildings - Require a waterproof treatment to prevent water ingress.

Log Cabins/Insulated Garden Rooms - Are supplied untreated and require a preservative and waterproofing treatment.

We also recommend using a silicon sealant on the inside and outside of the windows as soon as possible after assembly and treatment to fully seal the windows.

Roofing felt/covering should be checked annually and replaced or fixed accordingly.

4 General maintenance and wood characteristics

As wood is a natural material it may be affected by the following:

Shrinkage and warping - The timber used in the construction of your garden building will have retained some of its natural moisture content. The moisture content of the timber will vary, depending upon prevailing environmental conditions, which will result in the components either naturally expanding or contracting. As the components dry out, shrinkage may occur. A good waterproofing treatment from the start is the best protection to minimise the effect of moisture loss/intake.

In extended periods of very warm weather getting some moisture to the building will help the overall balance. You can do this by spraying it down lightly with a garden hose. In contrast, after snow fall try to remove the snow as best as possible from the roof to prevent moisture intake and to remove the extra weight.

Top tip - using a garden brush will help you to reach the highest part of the building to remove snow and any debris left from bad weather.

Damp and mould - During the winter months, cold and damp conditions can result in an increased amount of moisture within your garden building, especially when used infrequently. Condensation can form on the timber and other items stored within your garden building. If left this moisture is likely to cause mould and mildew.

To prevent the build-up of moisture, we recommend leaving the door or windows of your building open from time to time, to allow the fresh air to circulate. We also advise against storing wet or damp items in your garden building as this will also increase the level of moisture in the building. If mould or mildew does start to form within your building we recommend using an anti-mould cleaner to remove it and to prevent it spreading, which if left untreated could permanently damage your garden building.

Splits, cracks and knots - You may notice small splits and cracks in some components or holes may appear where knots shrink and fall out. This will not affect the structure of your Garden building however, if you wish to fill them this can be easily done using any good quality wood filler.

Sap - is naturally occurring in wood and may appear in some boards of your garden building. If you wish to remove the sap, we advise waiting until it is dry and then using a sharp knife to carefully remove it. If the removal of the sap causes a hole in the timber, we recommend using a good quality wood filler to fill it.

For more handy hints and tips on how to care and maintain your garden building please refer to the MGP Customer Portal at www.mgplogistics.co.uk

Any further questions?

Contact our
Customer Service Team via the MGP
Customer Portal at:
www.mgplogistics.co.uk

1

Manufacturer's Warranty

All Mercia Garden Products are supplied with a 1 year warranty on all parts against manufacturing defects.

This warranty does not cover movement, warping or splitting of timber products over time.

This warranty will be voided if any of the following occur:

1. The building has been customised or modified/adapted in any way.
2. The person claiming is not the original purchaser of the building.
3. Any damage has been caused by or as a result of misuse.
4. The building has not been maintained and cared for in accordance to our advisories and manufacturer's recommendations.
5. The building has not been treated annually or as per the manufacturer's recommendations, please ensure receipts are kept to validate this claim.
6. The building has not been erected, fitted or installed as per the supplier instructions.
7. The building has not been erected on a suitable sized firm flat, solid level concrete/slab base or placed on pressure treated bearers.
8. The building is or has been placed with 2 feet (600mm) of any obstructions (walls, trees, plants, fences etc.) which can allow moisture to penetrate the timber.
9. The roofing felt has been incorrectly fitted or damaged, allowing water ingress, or has not been properly maintained.
10. Any windows and joints have not been sealed, inside and out, with silicone or other watertight sealant.
11. Any timber has been cut, pierced or drilled without subsequent application of approved cut-end treatment.

2

Anti-rot Guarantee

Mercia Garden Products offer a 10 year anti-rot guarantee on all dip treated (a preparatory treatment) and 15 years on all pressure treated products. This guarantee covers solid timber against rot, decay, blue stain and insect attacks.

To validate the guarantee, the building must be treated (as detailed within manufacturer's recommendations) within 14 days (weather permitting) of assembly and annually thereafter.

This guarantee does not cover movement, warping or splitting of timber products over time.

This guarantee will be voided if any of the following occur:

1. The building has been customised or modified/adapted in any way.
2. The person claiming is not the original purchaser of the building.
3. Any damage is caused by or as a result of misuse.
4. The building has not been maintained and cared for in accordance to our advisories and manufacturer's recommendations.
5. The building has not been treated annually or as per the manufacturer's recommendations, please ensure receipts are kept to validate this claim.
6. The building has not been erected, fitted or installed as per the supplier instructions.
7. The building has not been erected on a suitable sized firm flat, solid level concrete/slab base or placed on pressure treated bearers.
8. The building is or has been placed with 600mm of any obstructions (walls, trees, plants, fences etc.) which can allow moisture to penetrate the timber.
9. The roofing felt has been incorrectly fitted or damaged allowing water ingress, or has not been properly maintained.
10. Any windows and joints have not been sealed, inside and out, with silicone or other watertight sealant.
11. Any timber has been cut, pierced or drilled without subsequent application of approved cut-end treatment.



REGISTER FOR YOUR
ANTI-ROT
GUARANTEE TODAY

PLEASE SCAN HERE:

