

03DTSHPN1008FGC31TWSA-V2
10X8 SHIPLAP PENT SUMMERHOUSE.

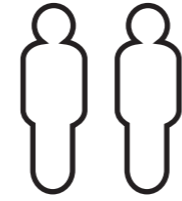

x2
All buildings should be erected by two adults

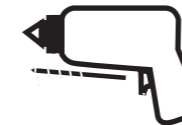

2mm Drill bit

For ease of assembly, you **MUST** pilot drill all screw holes and ensure all screw heads are countersunk.



For ease of assembly, you will need a tape measure to check dimensions of components and fixings.



Winter = High Moisture = Expansion
Summer = Low Moisture = Contraction



CAUTION
Every effort has been made during the manufacturing process to eliminate the prospect of splinters on rough surfaces of the timber. You are strongly advised to wear gloves when working with or handling rough sawn timber.

REGISTER FOR YOUR
10 YEAR
ANTI-ROT
GUARANTEE TODAY

In all instances for assistance with your product or to register your anti rot guarantee, please contact us via our customer portal



www.mgplogistics.co.uk

Mercia Garden Products Limited, Sutton On Trent, Newark, Nottinghamshire, NG23 6QN

BEFORE YOU START PLEASE READ THE INSTRUCTIONS CAREFULLY

- Check the pack and make sure you have all the items listed in the parts list provided.
- When you are ready to start, make sure you have the right tools at hand (not supplied - see the equipment list on next page).
- Ensure there is plenty of space and a clean dry area for assembly.
- Ensure you have enough time to build the product to ensure the building is water tight.

LOCATION FOR YOUR GARDEN BUILDING

A minimum of 600mm should be left around the perimeter of your garden building to allow access for maintenance, annual treatment and to allow air flow around the building.

Where possible you should avoid placing your garden building underneath large trees to prevent the tree causing damage to the building.

BUILDING A BASE

When thinking about where the building and where the base is going to be constructed: Ensure that there will be access to all sides for maintenance work and annual treatment.

Ensure the base is level and is built on firm ground, to prevent movement. Refer to the contents page for the base dimensions. The base should be slightly smaller than the external measurement of the building, i.e. The cladding should overlap the base, creating a run off for water. It is also recommended that the floor be at least 25mm above the surrounding ground level to avoid flooding.

TYPES OF BASE

- Concrete 75mm laid on top of 75mm hard-core.
- Slabs laid on 50mm of sharp sand.
- Wooden base - Levelled / on posts / ground screws.

TREATMENT

Once your garden building has been installed it will need to be treated within 14 days (weather permitting) and annually to prevent the timber from deteriorating and to waterproof it. This is required to maintain the anti-rot guarantee.

Dip Treated buildings - Require a preservative treatment to protect against rot and decay and a waterproof treatment to prevent water ingress

Pressure Treated buildings - Require a waterproof treatment to prevent water ingress

Log Cabins/Insulated Garden Rooms - Are supplied untreated and require a preservative and waterproofing treatment.

TIMBER

As with all natural materials, timber can be affected during various weather conditions. For the duration of heavy or extended periods of rain, swelling of the wood panels may occur. Warping of the wood may also occur during excessive dry spells due to an interior moisture loss. Unfortunately, these processes cannot be avoided but can be helped. It is suggested that the outdoor building is sprayed with water during extended periods of warm sunshine and sheltered as much as possible during rain or snow.

****Protim Aquatan T5 (621)****

Your building has been dip treated with Aquatan.

Aquatan is a water-based concentrate which is diluted with water, the building has been treated by the correct application of Aquatan solution and then allowed to dry.

Aquatan is a decorative finish to colour the wood, which is applied industrially to timber fence panels and garden buildings.

Aquatan undiluted contains: boric acid, sodium hydroxide 32% solution, aqueous mixture of sodium dioctyl sulphosuccinat and alcohols: 2, 4, 6-trichlorophenol.

Screws & Nails

Measure overall length

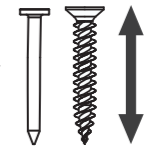

Bolts

Measure under the head

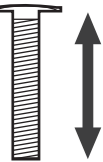

TO DO LIST

- Find a suitable location to build *(see front cover for further information)*.
- Build a base *(see front cover for further information)*.
- Check the base is flat, level, clear of debris and has 60cm clearance on all sides.
- Check you have the required equipment / tools.
- Check you have all the product items listed *(if you have missing or damaged parts please scan the QR code below to visit our online customer portal)*.
- Install the product as per the step by step instructions within this pack.
- Prepare the product ready for treatment (this may include sanding).
- Apply a preserving and a waterproofing treatment within 14 days *(weather permitting)* of installation *(pressure treated products do not require a preserver)*.
- Register for your anti rot guarantee *(scan the QR below)*.
- Tidy the build area and dispose of any remaining parts responsibly.
- Maintain your building *(see the manufacturers recommendations at the back of this pack)*.

EQUIPMENT LIST

- Hammer
- Flat Head Screwdriver
- Drill
- Drill Bit Set
- Phillips and Slotted Bit Sets
- Tape Measure
- Hand Saw
- Spirit Level
- Ladders/Steps
- Stanley Knife/Cutting Tool
- Sand Paper
- Gloves
- Silicone (For Windows Only)
- Sealant Application Gun
- Wood Filler (Optional)
- Timber Preservative Treatment *(not pressure treated products)*
- Timber Water Proofing Treatment
- Treatment Mixing Stick
- Paint Brush/Sprayer/Roller

NEED EXTRA SUPPORT

If you are unsure that your base preparation will be suitable, please contact us via our customer portal to discuss this further.

Alternatively, you can visit our website or MGP Logistics Online Portal for some further shededucation.

Website:

<https://www.merciagardenproducts.co.uk/sheducation>

MGP Logistics Online Portal:

<https://www.mgplogistics.co.uk/>

Here you will find plenty of useful information that'll help with most pre-installation and maintenance queries.

**ANY QUESTIONS?**

Scan the QR code to contact us via our customer portal.

NOTES

ACCESSING VIDEO GUIDES...

Some steps within this set of instructions come with an added video guide for your convenience. These can be accessed via the QR code and used to aid you in constructing that step. See below for how to use.

You can also find all the videos on our youtube channel:
<https://www.youtube.com/@merciagardenproducts8716/videos>

1. Find the QR code within the instruction step...

Step.....

Parts Needed- No. QTY 1
No. QTY 1
No. QTY 1

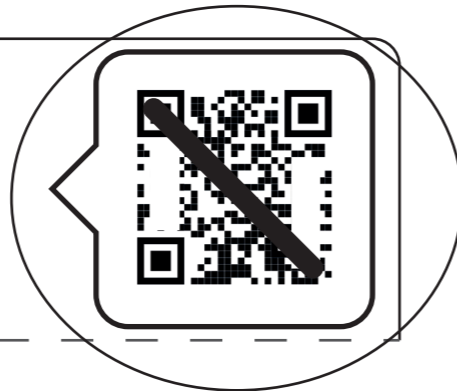

Within the instruction step, there will be an icon in the top right that has a QR code in. This is where the video can be accessed from.

Please note: not every step has a video guide.

2. Open camera app...

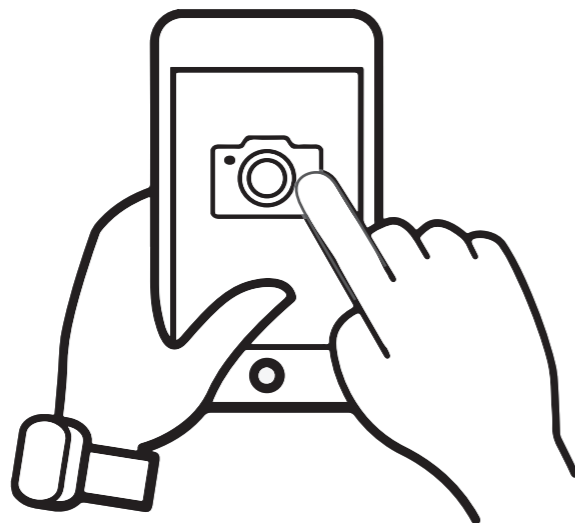

On your personal smart device (phone, tablet etc), open your camera app or QR code scanner app.

ACCESSING VIDEO GUIDES...

3. Scan QR code...



To scan the QR code, hold the camera over the QR code so that it can be seen on the screen. Once the QR code has been registered, follow the prompts on your device to open the video. (This will vary depending on your device.)

Please note: Ensure to use the back camera of your smart device as this will scan the QR code more accurately.

4. Watch the video...



The video guide will now be displayed on your smart device.

Disclaimer: The garden building constructed in the video guides may be constructed differently to your building. Please ensure to read your instructions carefully to avoid error.

03DTSHPN1008FGC31TWSA-V2

Overall Dimensions:

Width = 3024mm
 Depth = 2470mm
 Height = 2162mm

Base Dimensions:

Width = 2924mm
 Depth = 2395 mm

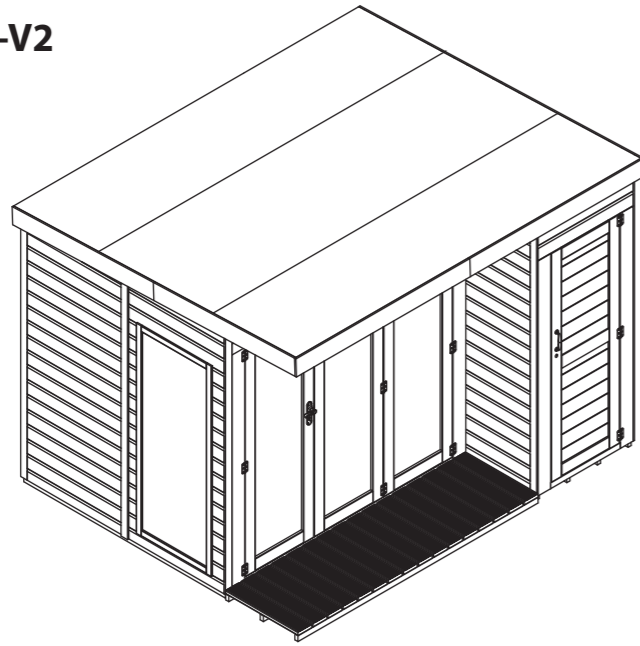

Contents:

Tip: Labelling your parts, using a pencil and masking tape, may help you to identify them easier when you need them.

NO.1 FLOOR PANEL

- 9**

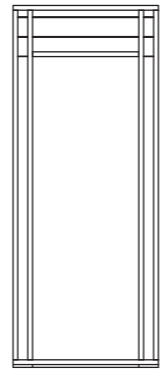

Storage Door Panel QTY 1
AI-03S21SHSD827X2060-V1

10



Veranda QTY 1
AI-S21STVF2087X628-V1

11

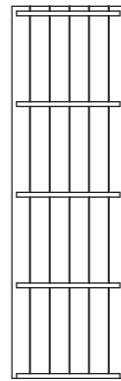

Under Roof QTY 1
AI-S21MBURF2118X641-V1

12



Storage Gable Left QTY 1
AI-03S21SHPLG571X2107-V1

13



Storage Gable Right QTY 1
AI-03S21SHPGR571X2107-V1
- 14**

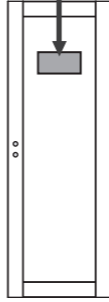

Master Door QTY 1
AI-PRMFGMD600X1715-V1

15

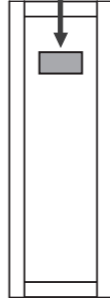

Secondary Door QTY 1
AI-PRMFGSD600X1715-V1

16

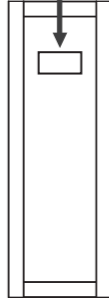

Plain Door QTY 1
AI-PRMFGPD600X1715-V1

17

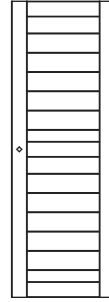

Storage Door QTY 1
AI-PRMFBMD600X1715-V1
- 18**

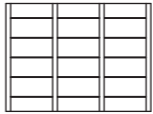

Storage Floor QTY 1
AI-S21MBF825X614-V1

19

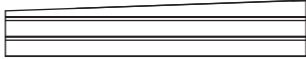

Double Boarded Gable Top QTY 1
AI-S21SHDBPGT1712X320-V1

20

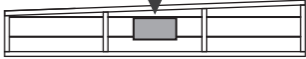

Gable Top Right QTY 1
AI-S21SHPGTR1712X320-V1

21

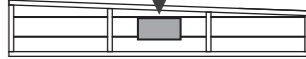

Gable Top Left QTY 1
AI-S21SHPGTL1712X320-V1
- 22**

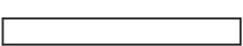

Floor Blocks - 27x44x400mm QTY 3
F2744-400mm
 - 23**

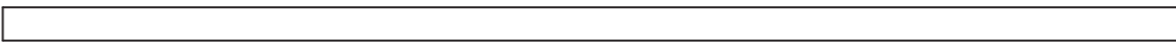

Cover Trim - 12x56x1980mm QTY 1
S1256-1980mm
 - 24**

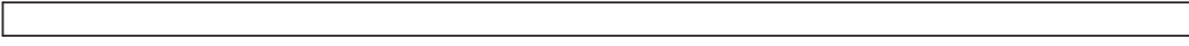

Cover Trim - 12x56x2000mm QTY 2
S1256-2000mm

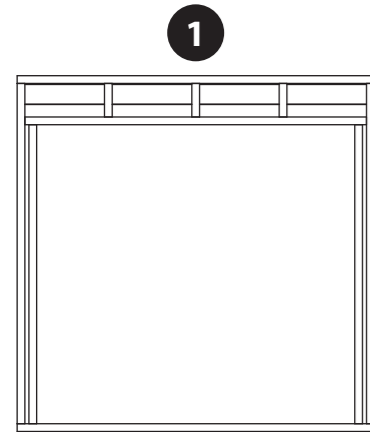

1 Door Panel QTY 1
AI-03S22SHTCD2033X2025-V1

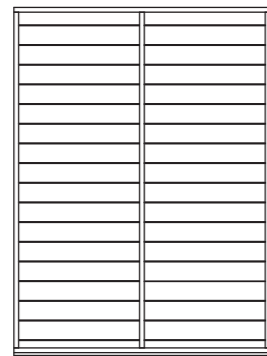

2 Back Panel QTY 2
1458mm x 1981mm
AI-S21SHPP1458X1981-V1

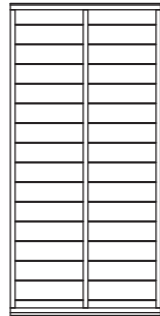

3 Short Panel QTY 1
856mm x 1776mm
AI-S21SHPPTOV856X1776-V1

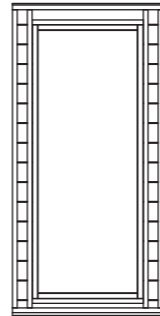

4 Short Window Panel QTY 1
AI-03S21SH1TFWC856X1776-V1

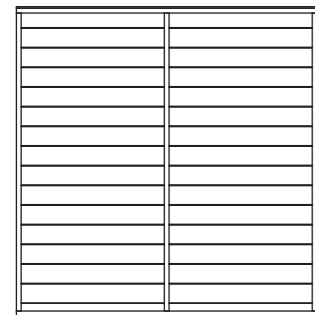

5 Internal Panel QTY 1
1712mm x 1760mm
AI-S21SHPPTOV1712X1760-V1

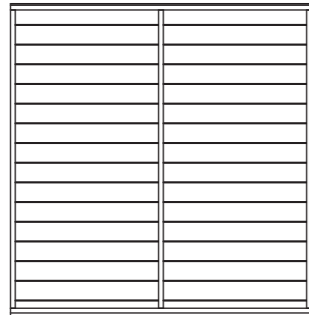

6 Side Panel QTY 1
1712mm x 1776mm
AI-S21SHPPTOV1712X1776-V1

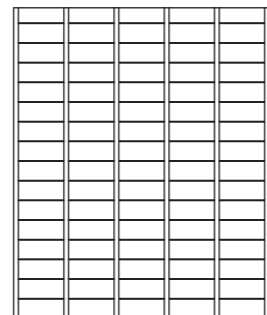

7 Floor QTY 2
AI-S21MBF1456X1753-V1

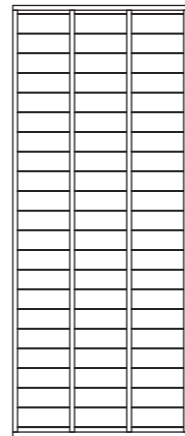

8 Roof QTY 3
AI-S21MBPR1000X2455-V1

- 

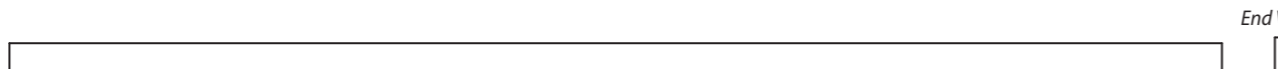
25 **Cover Trim - 12x56x2011mm QTY 1**
S1256-2011mm
- 

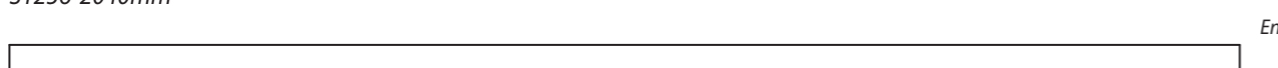
26 **Cover Trim - 12x56x2040mm QTY 1**
S1256-2040mm
- 

27 **Cover Trim - 12x56x2070mm QTY 1**
S1256-2070mm
- 

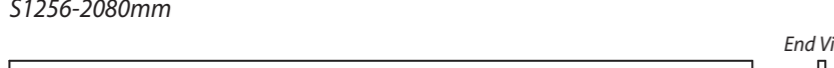
28 **Cover Trim - 12x56x2080mm QTY 2**
S1256-2080mm
- 

29 **Side Fascia - 12x111x1250mm QTY 4**
S12111-1250mm
- 

30 **Front Fascia - 12x111x1550mm QTY 2**
S12111-1550mm
- 

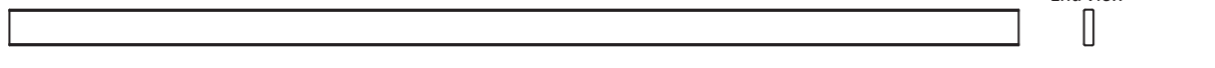
31 **Door Trim - 16x60x1698mm QTY 2**
S1660-1698mm (rounded edge)
- 

32 **Internal Panel Framing - 44x44x1905mm QTY 1**
F4444-1905mm
- 

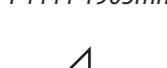
33 **Door Stop QTY 1**
PLY TRIANGLE
- 

34 **Handle QTY 1**
PI-07-0159
- 

35 **Door Handles QTY 2**
PI-07-0001

- 

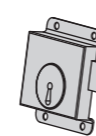
36 **Lock Block - 28x28x95mm QTY 2**
F2828-95mm
- 

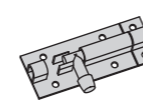
37 **Press Lock QTY 1**
PI-07-0162
- 

38 **Tower Bolt QTY 4**
PI-07-0114
- 

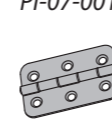
39 **Mortice Lock QTY 1**
PI-07-0017
- 

40 **Butt Hinge QTY 12**
PI-07-0066

Screw Pack

There may be extra screws in the pack

- 

70mm Screw x 6
- 

25mm Screw x 18
- 

50mm Screw x 125
- 

10mm Screw x 16
- 

40mm Screw x 8
- 

Felt Tacks x 300
- 

30mm Screw x 139

- 

41 **Key Plate QTY 1**
PI-07-0017
- 

42 **Turn Button QTY 4**
PI-07-0034
- 

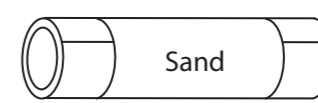
43 **Sand Capping Felt**
- 

44 **Sand Felt**
- 

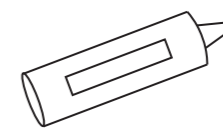
45 **Green Felt**
- 

46 **Butyl QTY 2**
PI-01-0042

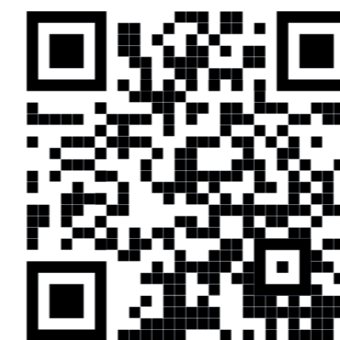

Missing parts?

Scan the QR code to visit our customer portal where you can quickly raise any missing or damaged parts and get a replacement sent out ASAP.



Pre Assembly

Before assembling remove the transportation blocks from the bottom of each panel.

Take care removing the blocks as to not damage the panels. Tap with a flat headed screwdriver and hammer.

Dispose of the blocks once removed.

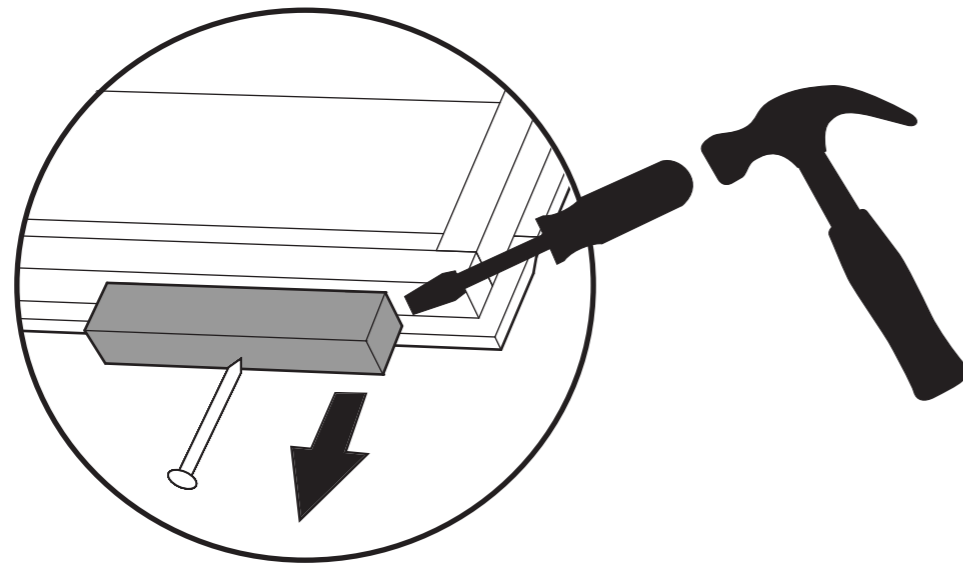

***This building can be constructed with the shed on either side. Please choose which side works best for you before beginning assembly.**

The images used in the steps show the shed being constructed on the right hand side. This is for illustrative purposes only. To construct our shed on the Left hand side please follow the same steps but be aware to position panels to the opposite side.*

Before assembly, please make sure you have a suitable base ready to install your building onto.

Step 1

Parts needed - No. 7 QTY 2

Place the floors (**No. 7**) onto your firm and level base. Ensure the base has suitable drainage free from areas where standing water can collect. (See front page on base requirements).

Fix the two floor panels together screwing at an angle through the cladding into the floor panel using 10x50mm screws in an alternating pattern.

10x50mm Screws



IMPORTANT: Pre-drill before fixing screws.

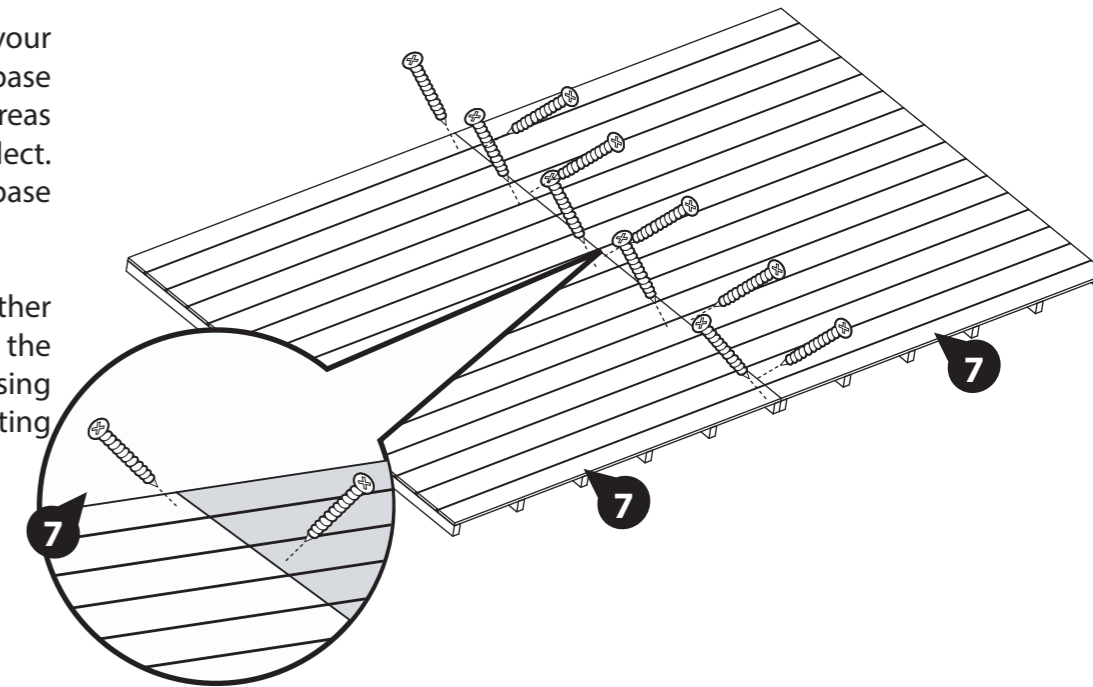

Step 2

Parts needed - No. 22 QTY 3

On the side of the building you wish to construct the shed area, position the Floor Blocks (**No. 22**) centrally between the floor bearers, as show.

***This steps shows the shed being constructed on the right hand side. To construct on the left, follow the same steps on the other side of your building.*

Secure the Blocks to the floor using 2x30mm screws per block, screwing through the cladding into the block below.

6x30mm Screws



IMPORTANT: Pre-drill before fixing screws.

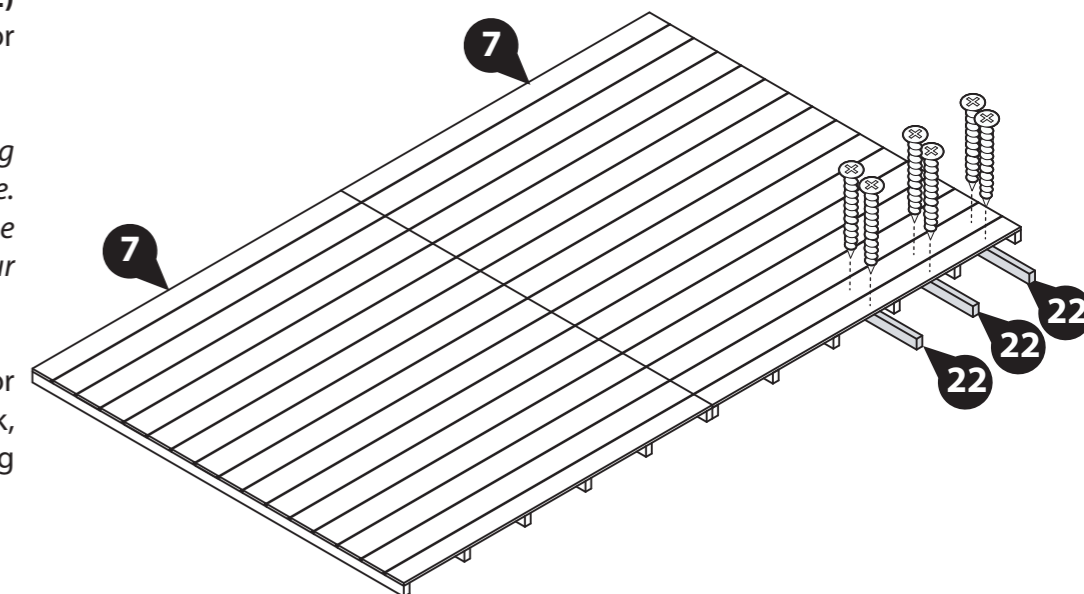

Step 3

Parts Needed - No. 18 QTY 1

Secure the Storage Floor (No. 18) to the assembly from Step 2, using 2x30mm screws per Floor Block.

6x30mm Screws

The images used in the steps show the shed being constructed on the right hand side. This is for illustrative purposes only. To construct your shed on the Left hand side please follow the same steps but be aware to position panels to the opposite side.

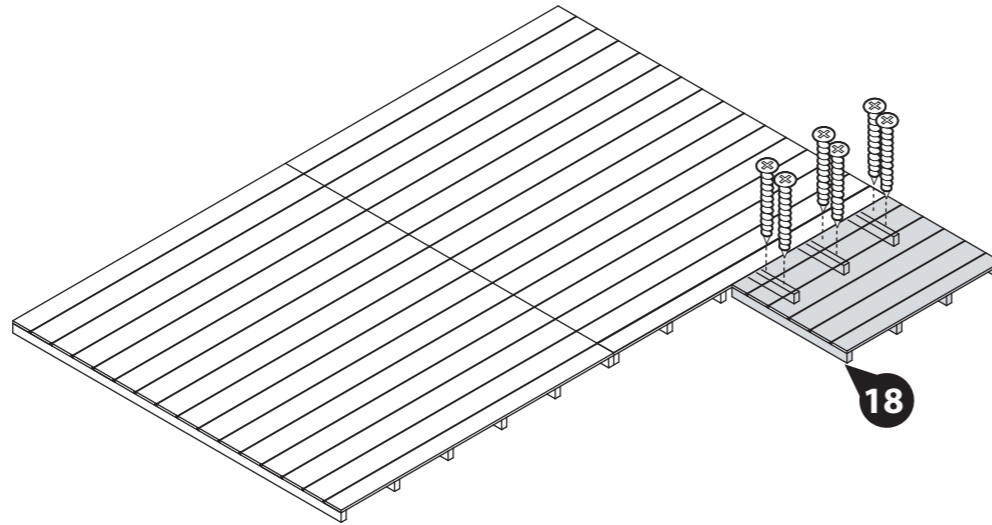

IMPORTANT: Pre-drill before fixing screws.

Step 5

Parts Needed - No. 4 QTY 1

Position one short window panel (No. 4) on top of the floor next to the previously fitted short panel (No. 3), as shown.

Fix the short panel (No. 3) and short window panel (No. 4) together using 4x50mm screws.

Do not secure the building to the Floor until the roof is fitted.

4x50mm Screws

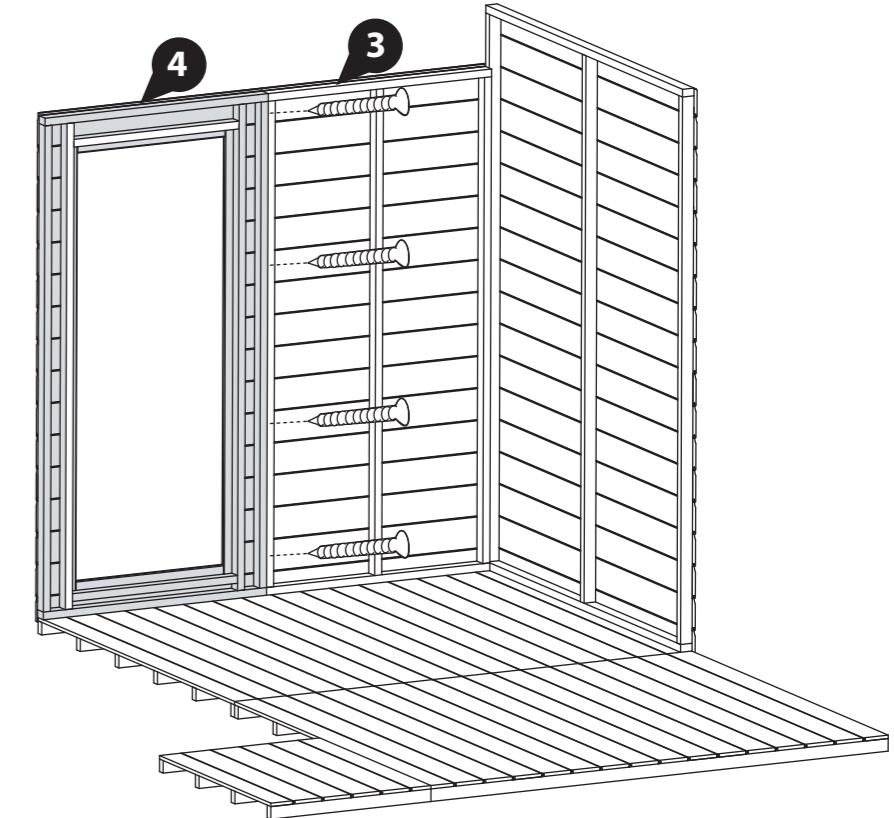

IMPORTANT: Pre-drill before fixing screws.

Step 4

Parts Needed - No. 2 QTY 1
No. 3 QTY 1

Locate one short panel (No. 3) and one back panel (No. 2) on top of the floor, as shown.

Fix the short panel (No. 3) to the back panel (No. 2) at the corner using 3x50mm screws as shown.

Do not secure the building to the Floor until the roof is fitted.

3x50mm Screws

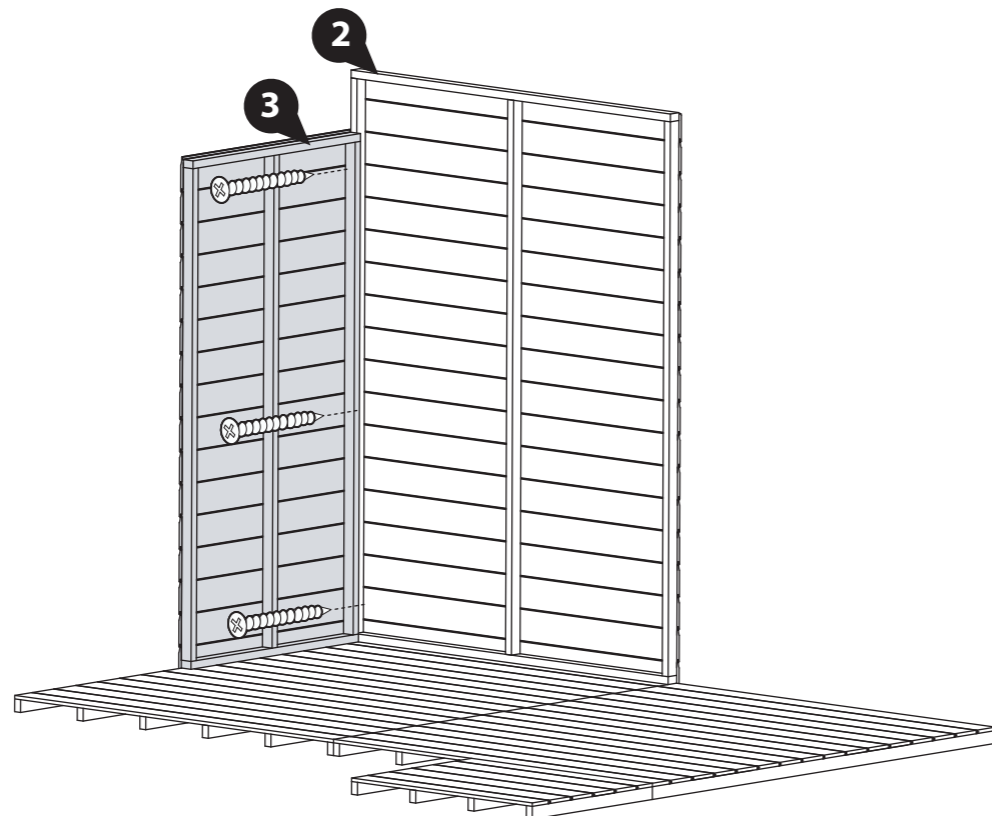
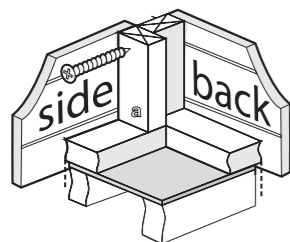

IMPORTANT: Pre-drill before fixing screws.

Step 6

Parts Needed - No. 2 QTY 1

Position a Back Panel (No. 2) on top of the floor, next to the other Back Panel as shown.

Fix the Back Panels (No. 2) together using 4x50mm screws.

Do not secure the building to the Floor until the roof is fitted.

4x50mm Screws

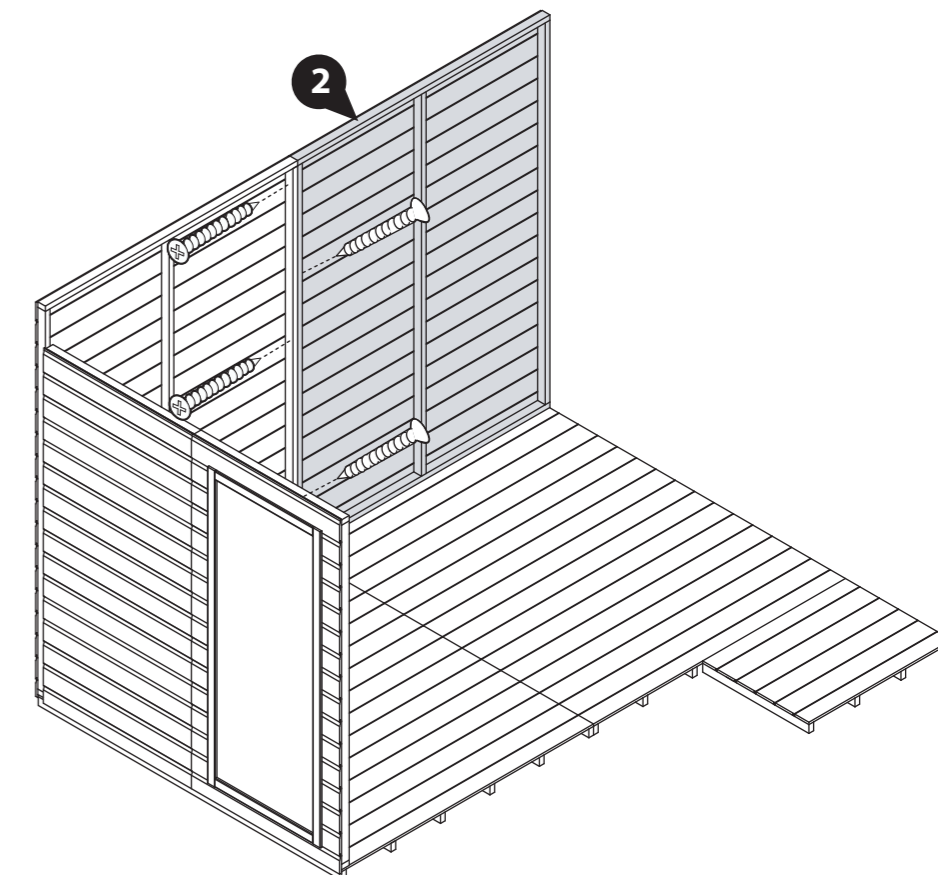

IMPORTANT: Pre-drill before fixing screws.

Step 7

Parts Needed - No. 1 QTY 1

Place the door panel (No. 1) on top of the floor, next to the Window Panel (No. 4) to create a corner.

Fix the panels together at the corner using 3x70mm screws, screwing through the external window panel cladding into the Door panel behind. Make sure that the Framing is flush with the other Framing, not the cladding.

Do not secure the building to the Floor until the roof is fitted.

3x70mm Screws



70mm screw

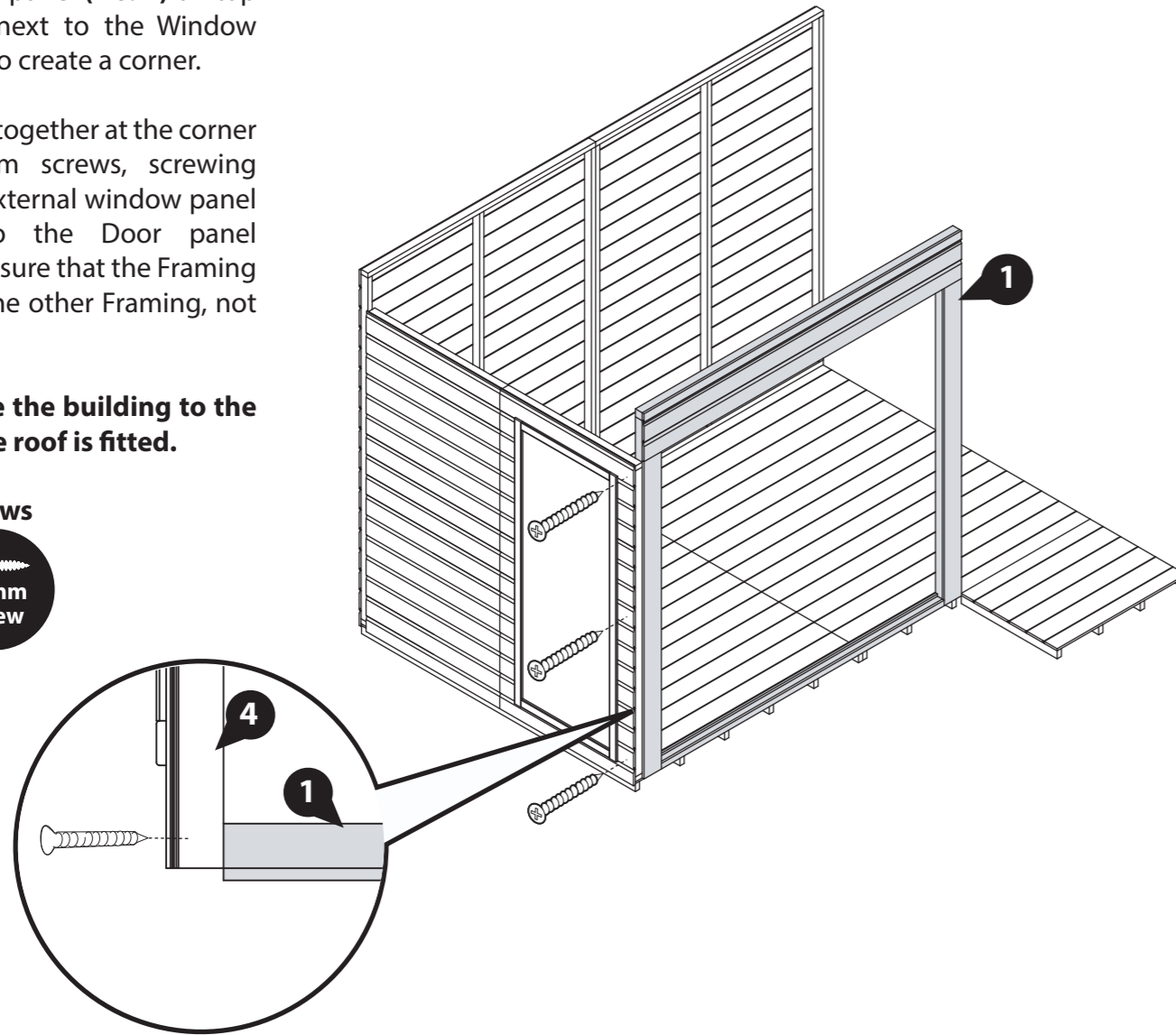

IMPORTANT: Pre-drill before fixing screws.

Step 8

Parts Needed - No. 5 QTY 1
No. 32 QTY 1

Fix the side Internal Panel (No. 5) against the framing of the Door Panel (No. 1) with 3x70mm screws as shown in the diagram externally. Make sure that the Framing is flush with other Framing, not the cladding.

Then fix the Internal Panel Framing (No. 32) to the otherside of the Internal Panel (No. 5) with 3x50mm screws as shown in the diagram internally.

Do not secure the building to the Floor until the roof is fitted.

3x50mm Screws

3x70mm Screws



50mm screw

70mm screw

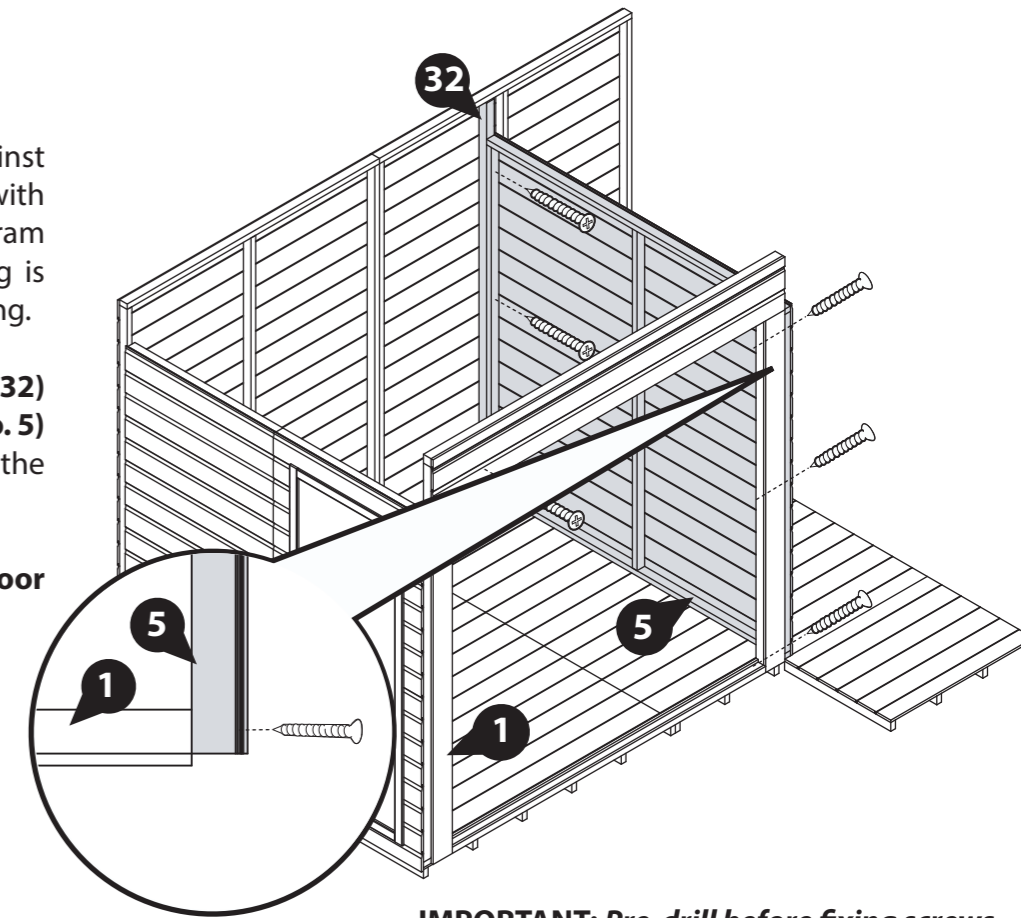

IMPORTANT: Pre-drill before fixing screws.

Step 9

Parts Needed - No. 20 QTY 1
No. 21 QTY 1

Place the Gable Top Left/Right (No. 20 & 21) on the top of the side panels, slotting the groove of the boarding on the gable into the tongue of the side panel as shown and screw internally.

Fix with 4x50mm screws per gable top as shown in the diagram.

8x50mm Screws



50mm screw

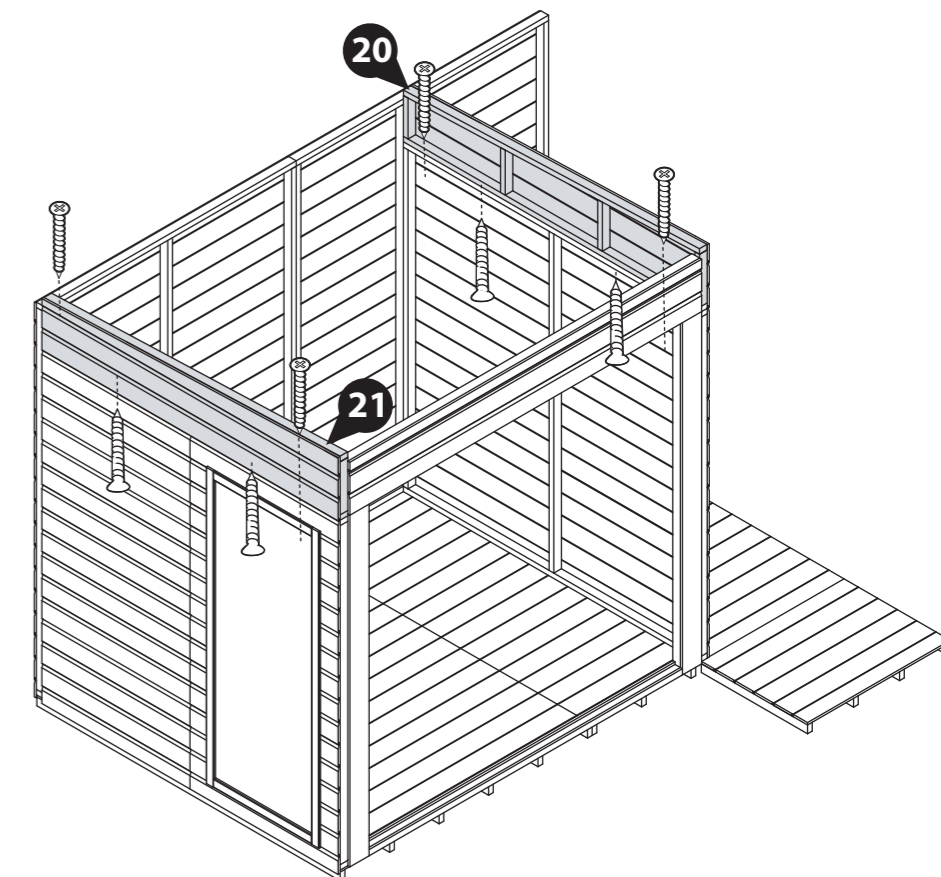
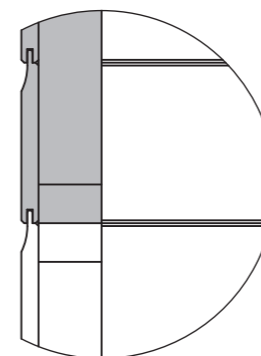

IMPORTANT: Pre-drill before fixing screws.

Step 10

Fix the Internal Panel Framing (No. 32) to the inside of the Back Panel (No. 2) using 4x50mm screws, screwing through the external Back Panel cladding into the framing behind.

Make sure that the panels are square and use the Gable Top Right (No. 20) as a guide so that you fix the screws correctly in a straight line.

4x50mm Screws

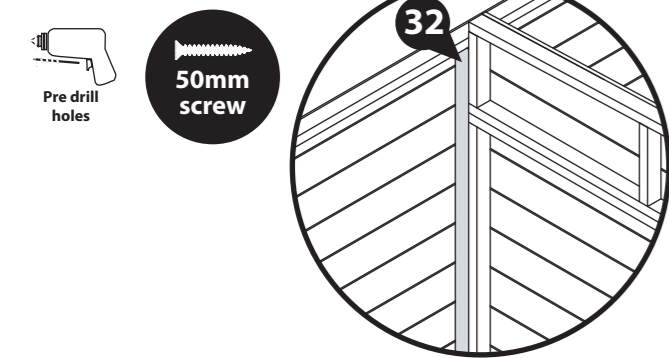

IMPORTANT: Pre-drill before fixing screws.

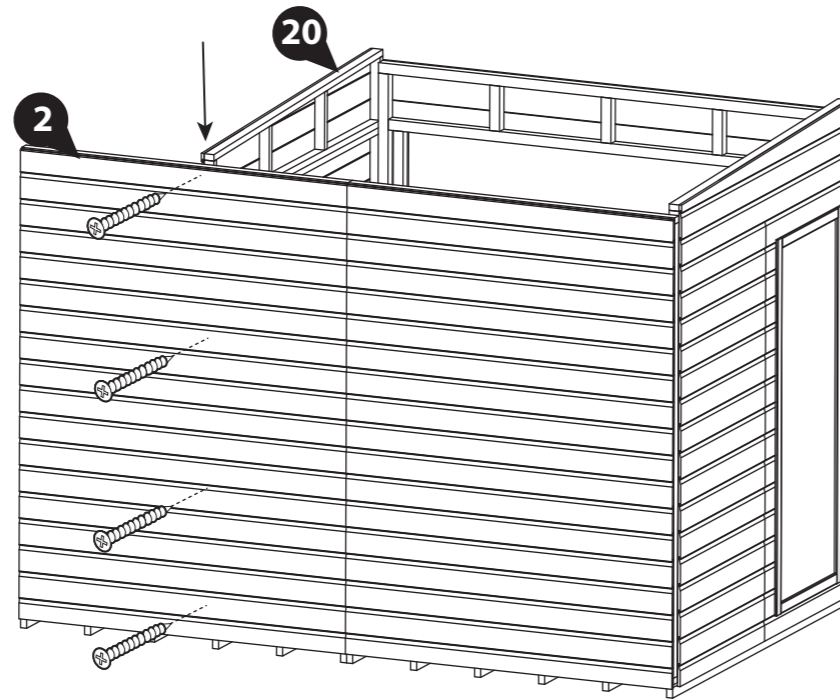

Step 12

Parts Needed - No. 19 QTY 1

Place the Double Boarded Gable Top (No. 19) on top of the Side Panel (No. 6) ensuring to slot the groove of the boarding on the gable into the tongue of the side panel as shown.

Fix with 4x50mm screws, screwing up through the panel framing into the Gable Top, as shown.

4x50mm Screws

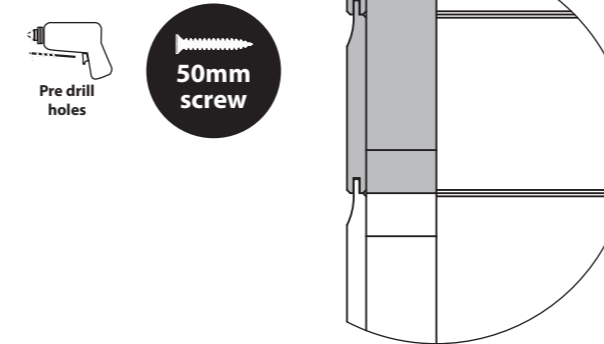

IMPORTANT: Pre-drill before fixing screws.

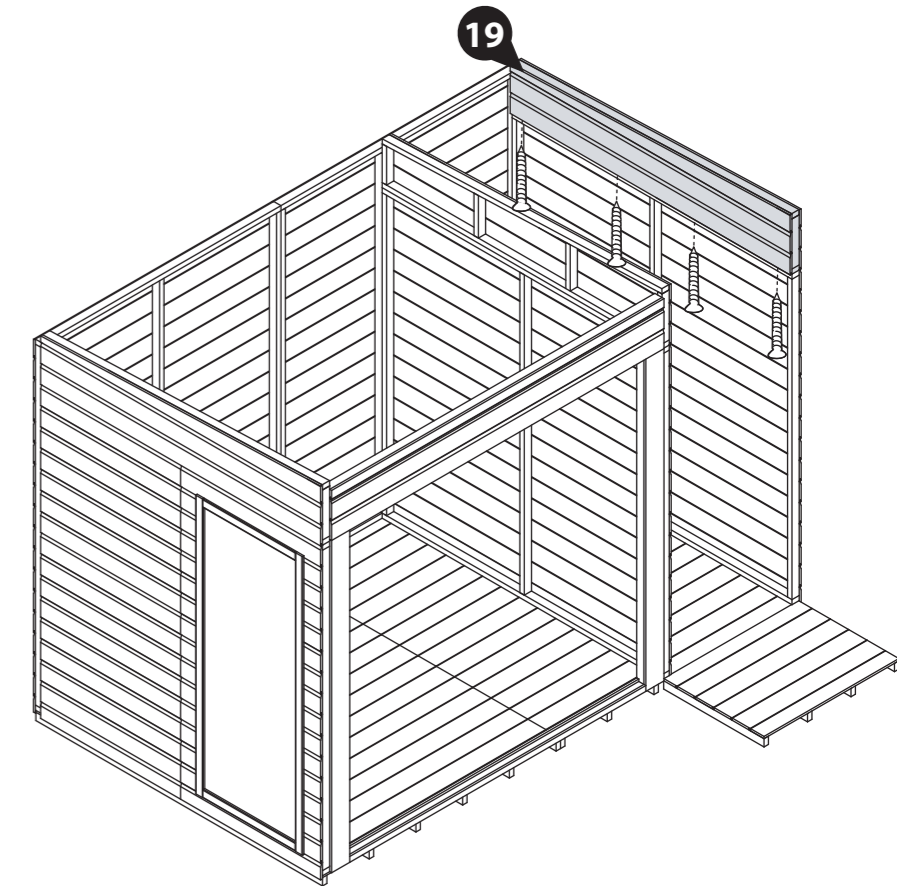

Step 11

Parts Needed - No. 6 QTY 1

Position the Side Panel (No. 6) on top of the floor, next to the Back Panel (No. 2) on the corner, as shown.

Fix the Side Panel (No. 6) and Back Panel (No. 2) together at the corner using 3x50mm screws.

Do not secure the building to the Floor until the roof is fitted.

3x50mm Screws

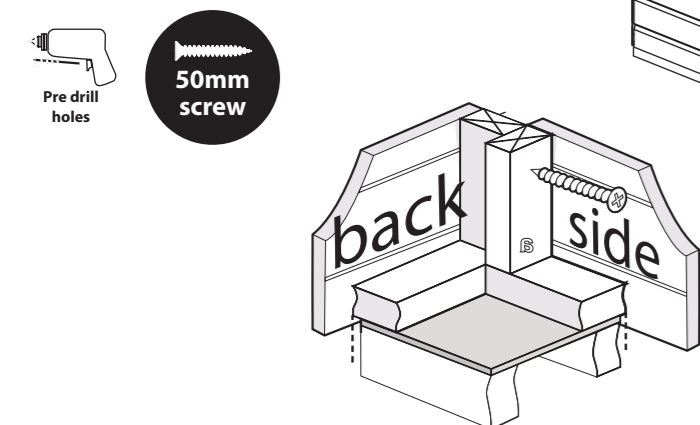

IMPORTANT: Pre-drill before fixing screws.

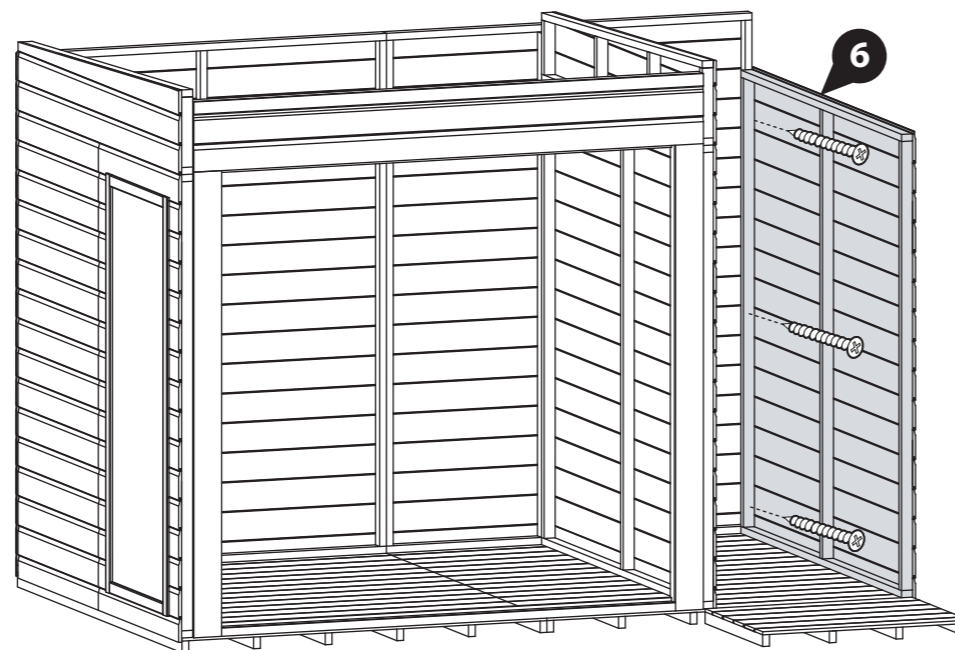

Step 13

Parts Needed - No. 12 QTY 1
No. 13 QTY 1

Position the Storage Gable Sides Left/Right (No. 12 & 13) on top of the floor, against the sides of the Internal (No. 5) and Side Panel (No. 6) with the boarding facing outwards, as shown.

Fix each panel to the adjacent panel using 4x50mm screws.

Do not secure the building to the Floor until the roof is fitted.

8x50mm Screws



IMPORTANT: Pre-drill before fixing screws.

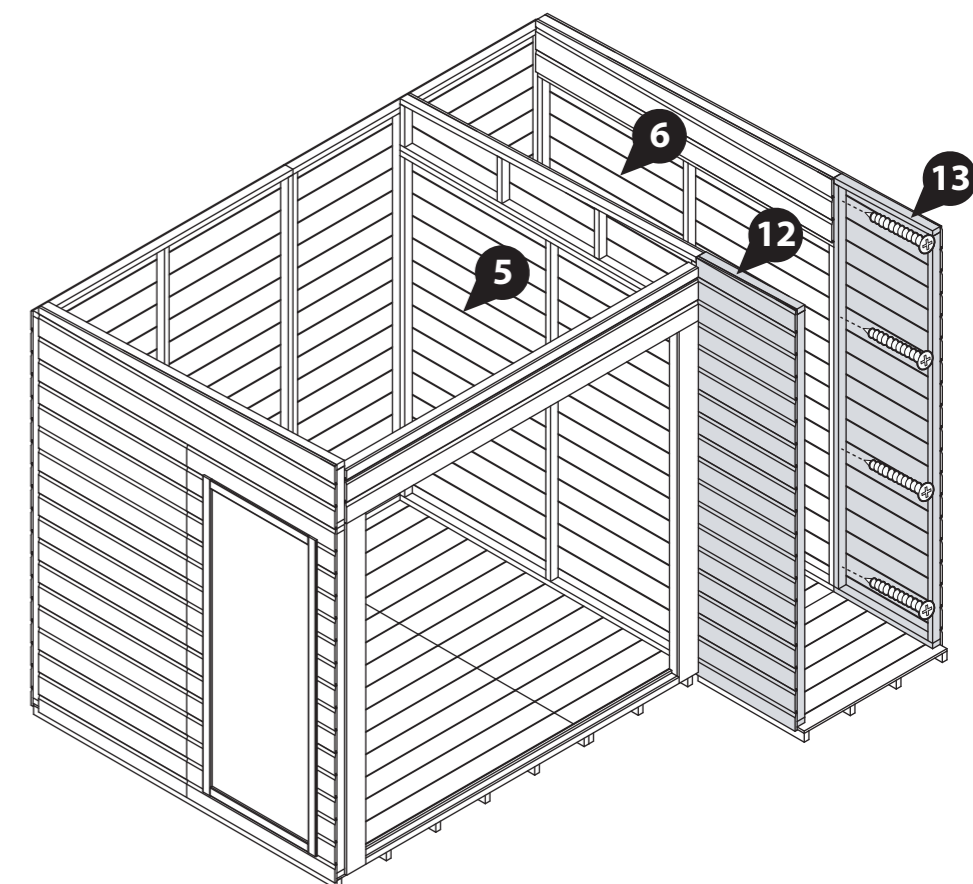

Step 14

Parts Needed - No. 16 QTY 1
No. 40 QTY 3

Position the Plain Door (No. 16) to the right hand side of the Door Panel opening, ensuring there is equal spacing around the top, bottom and side.

Locate three butt hinges (No. 40) onto the door and door panel, as shown. Fix the Hinges to the door and Door panel using 6x30mm screws per hinge.

18x30mm Screws



IMPORTANT: Pre-drill before fixing screws.

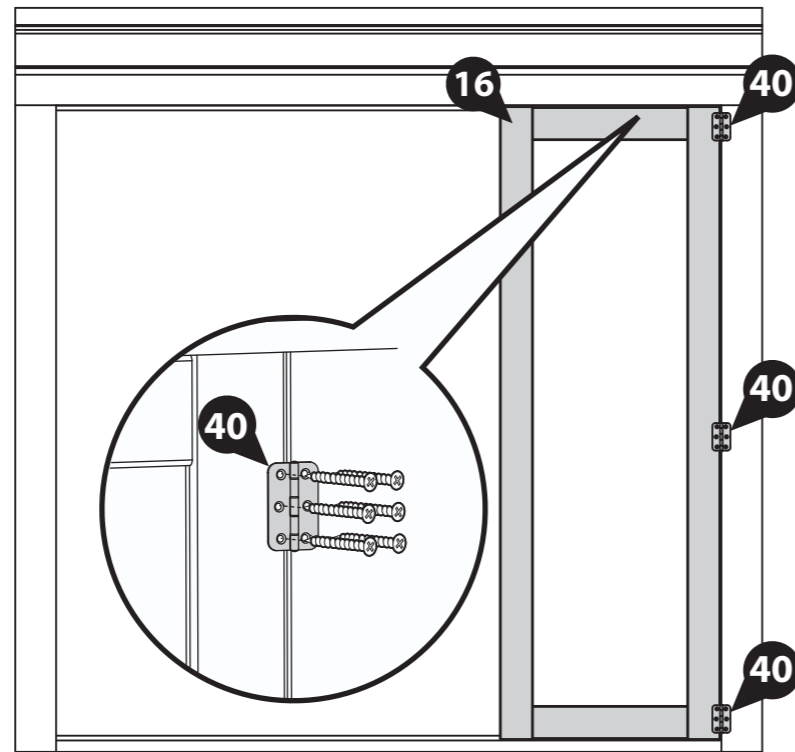

Step 15

Parts Needed - No. 15 QTY 1
No. 14 QTY 1
No. 40 QTY 6

Position the master door (No. 14) to the left side of the door panel and the secondary door (No. 15) in between the attached plain door and master door, as shown. Ensure there is equal spacing around each side.

Locate three butt hinges (No. 40) onto the master door and door panel, and three hinges onto the Secondary door and plain panel, as shown.

Fix the Hinges in place using 6x30mm screws per hinge.

***Ensure the doors open freely, folding back into the building unrestricted.**

36x30mm Screws



IMPORTANT: Pre-drill before fixing screws.

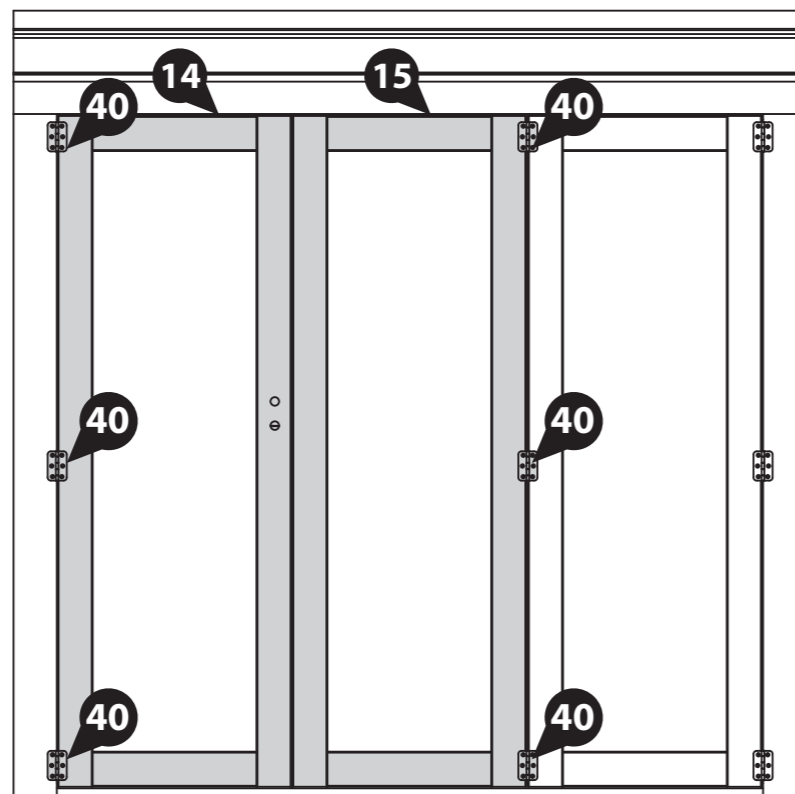

Step 16

Parts Needed - No. 31 QTY 2
No. 35 QTY 2
No. 38 QTY 4
No. 39 QTY 1
No. 41 QTY 1

a Locate the mortice lock (No. 39) into the recess and fix in place with the screws provided. Locate the key plate (No. 41) to the opposite door using the 4x30mm screws provided.

b Fix door handles (No. 35) using 8x30mm screws.

c Position the Door Trims (No. 31) to the inside of the plain (No. 16) and secondary doors (No. 15). Ensure there is small overhang over the adjacent right hand door.

Fix in place using 3x30mm screws per trim.

d Place the Tower Bolts (No. 38) roughly into position at the top and bottom of the Door trims. With a pencil, mark around the bolt.

After marking the bolt onto the strips, drill a hole for the barrel bolt to locate into.

e Re-position the tower bolts into position and secure using 4x10mm screws per bolt.

Ensure doors open and close freely.

10x30mm Screws

16x10mm Screws

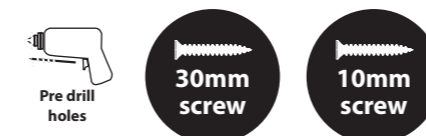

IMPORTANT: Pre-drill before fixing screws.

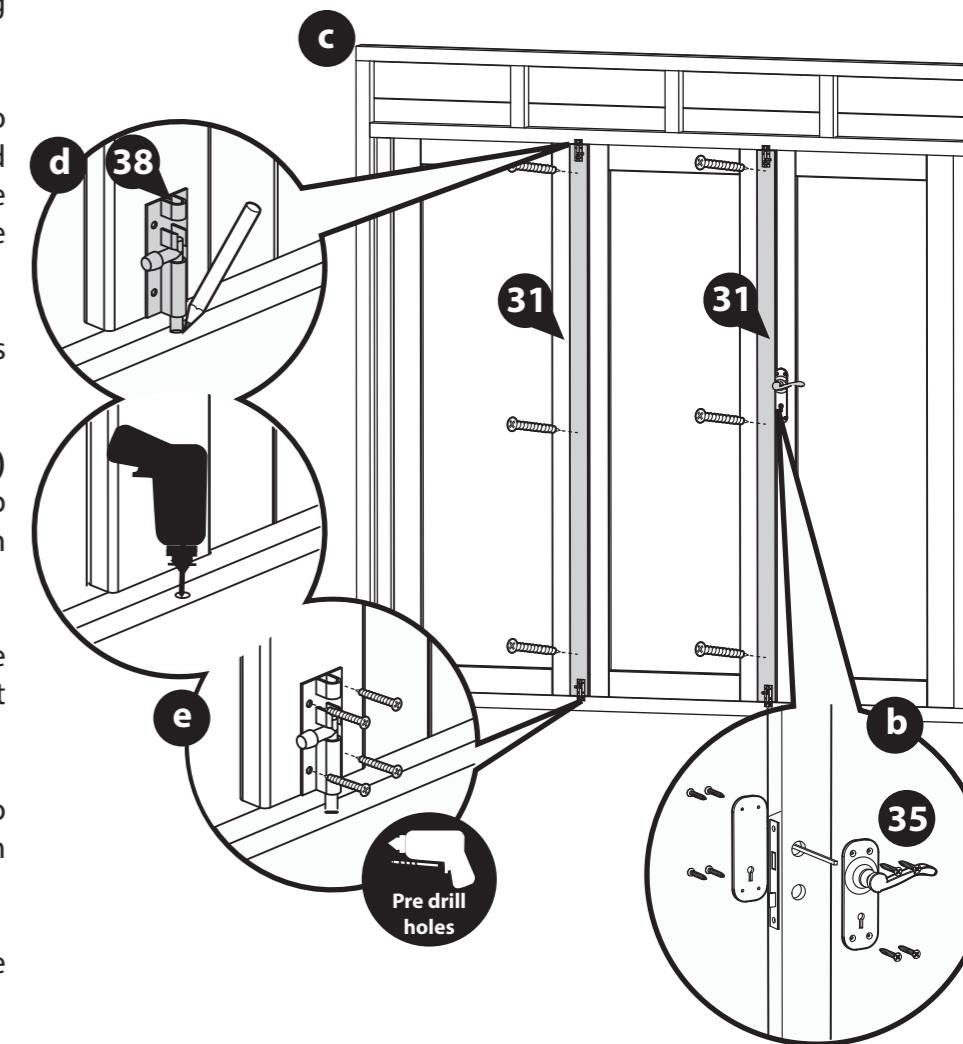
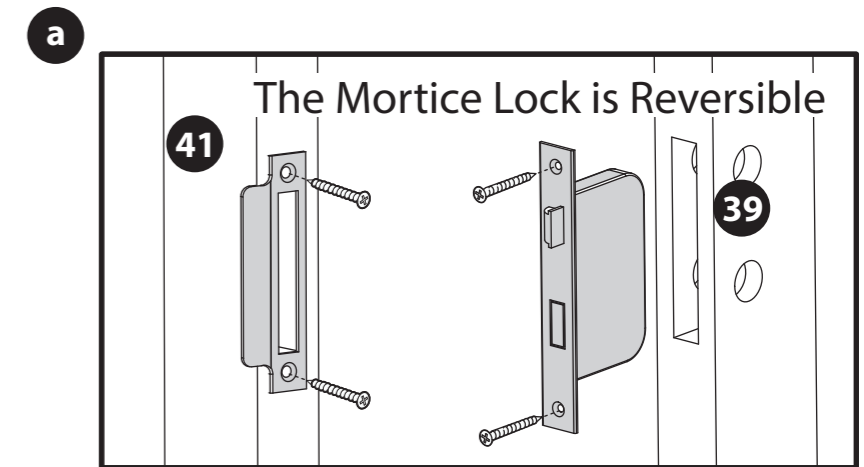

Step 17

Parts Needed - No. 9 QTY 1

Position the Storage Door panel (No. 9) on top of the floor, against the end of the Storage Gable Sides (No. 11 & 12).

Fix in place using 4x50mm screws per side, screwing through the Gable side panels into the Door panel framing.

Do not secure the building to the Floor until the roof is fitted.

8x50mm Screws

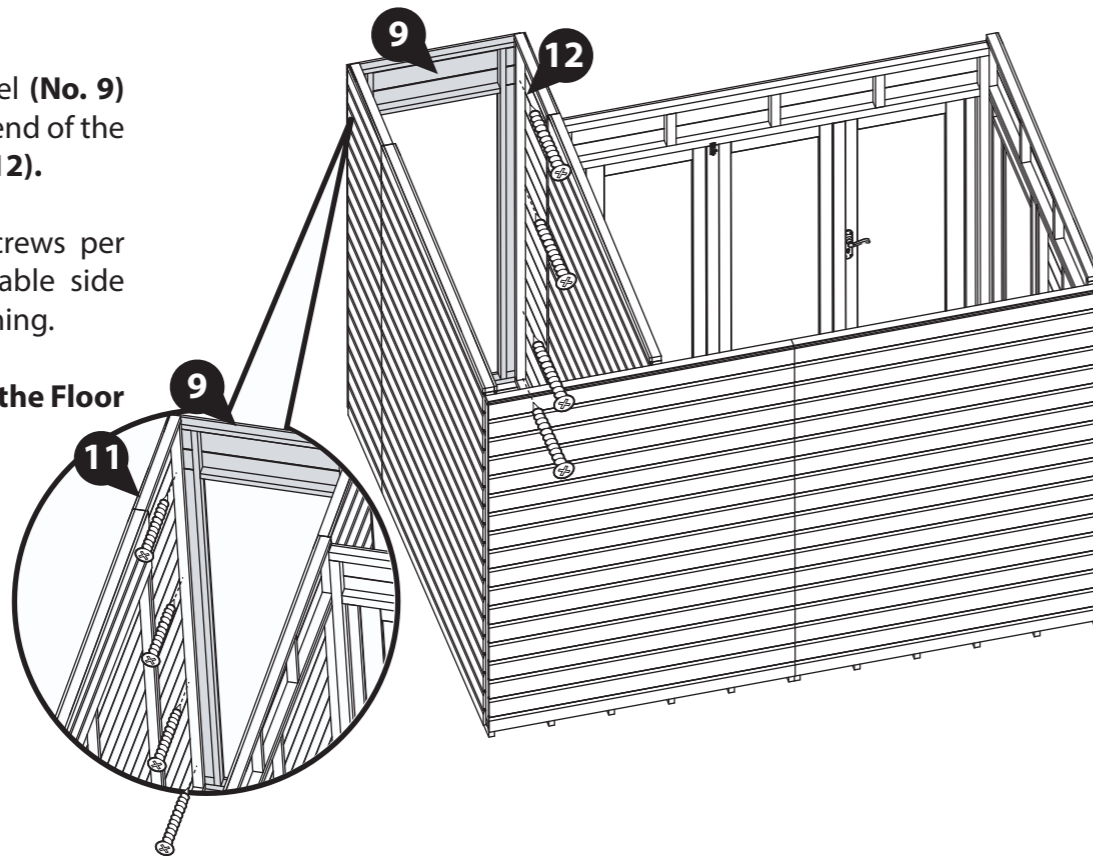

IMPORTANT: Pre-drill before fixing screws.

Step 19

Parts Needed - No. 10 QTY 1

Place the Veranda (No. 10) flush to the front of the building, as shown.

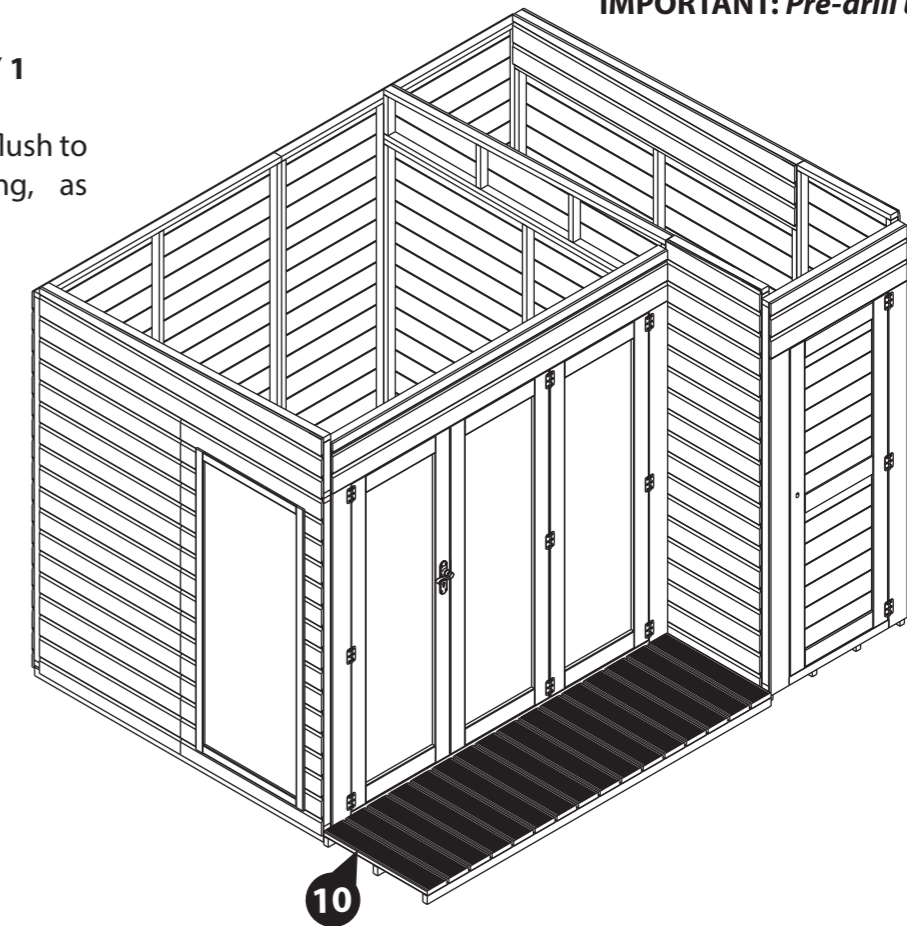

IMPORTANT: Pre-drill before fixing screws.

Step 18

Parts Needed - No. 17 QTY 1
No. 40 QTY 3

Position the storage door (No. 17) centrally in the Storage Door Panel opening.

Locate three Butt hinges (No. 40) to the Storage Door and the storage door panel. Fix the Hinges to the door and Door panel using 6x30mm screws per hinge.

Do not secure the building to the Floor until the roof is fitted.

18x25mm Screws

Storage Door hinges fitted on the right hand side of the door which means that your door will open on the left side.

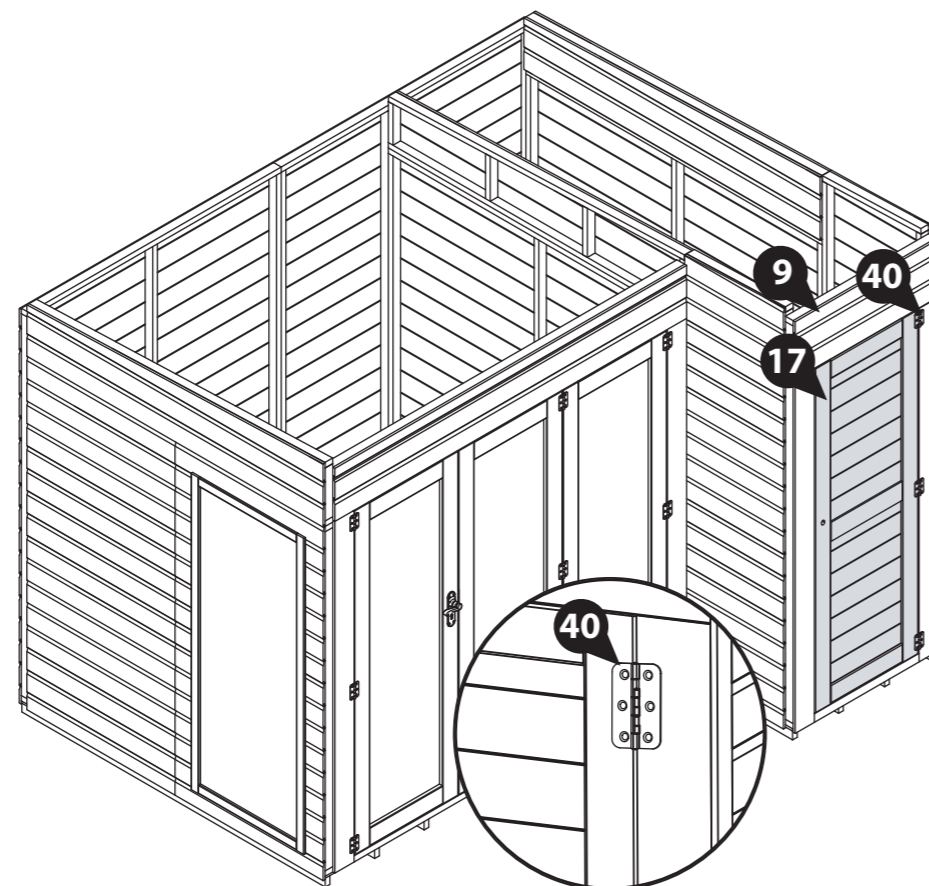
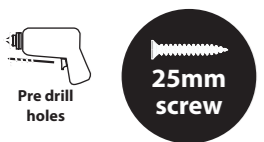

IMPORTANT: Pre-drill before fixing screws.

Step 20

Parts Needed - No. 8 QTY 3

Place the Roof Panels (No. 8) onto the top of the building. Align the three Roof Panels so they sit square before fixing into position.

Do not secure the building to the Floor until the roof is fitted.

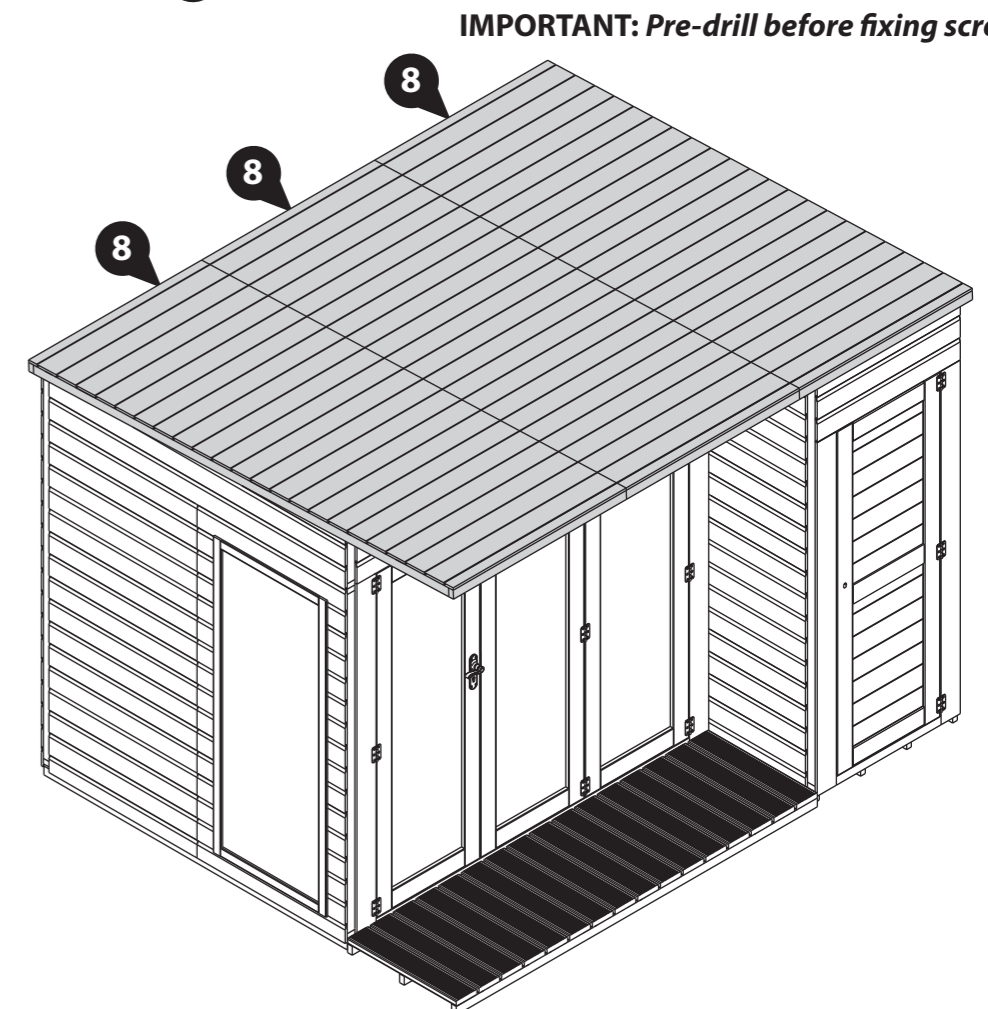

IMPORTANT: Pre-drill before fixing screws.

Step 21

Internally, fix the three Roof panels together in an alternating pattern using 8x50mm screws per join.

Do not secure the building to the Floor until the roof is fitted.

16x50mm Screws

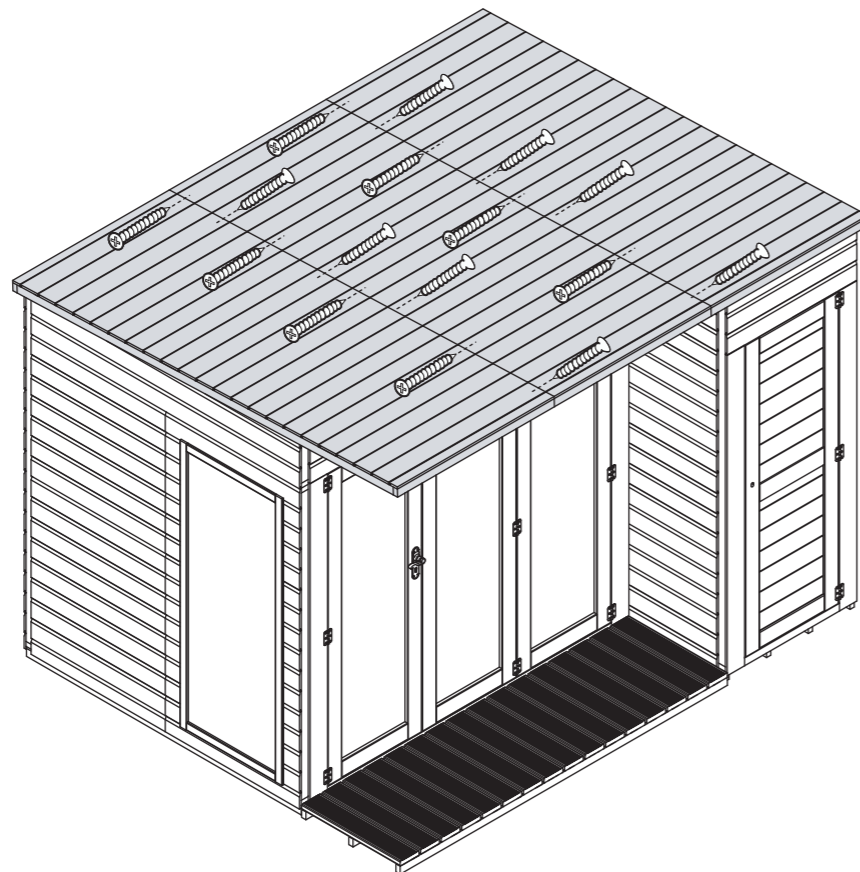

IMPORTANT: Pre-drill before fixing screws.

Step 23

Internally, secure the Wall Panels to the Roof panes using 6x50mm screws per roof.

Ensure to screw up through the front and back wall panels framing into the roof framing above.

Do not secure the building to the Floor until the roof is fitted.

External panels not shown for illustrative purposes.

18x50mm Screws

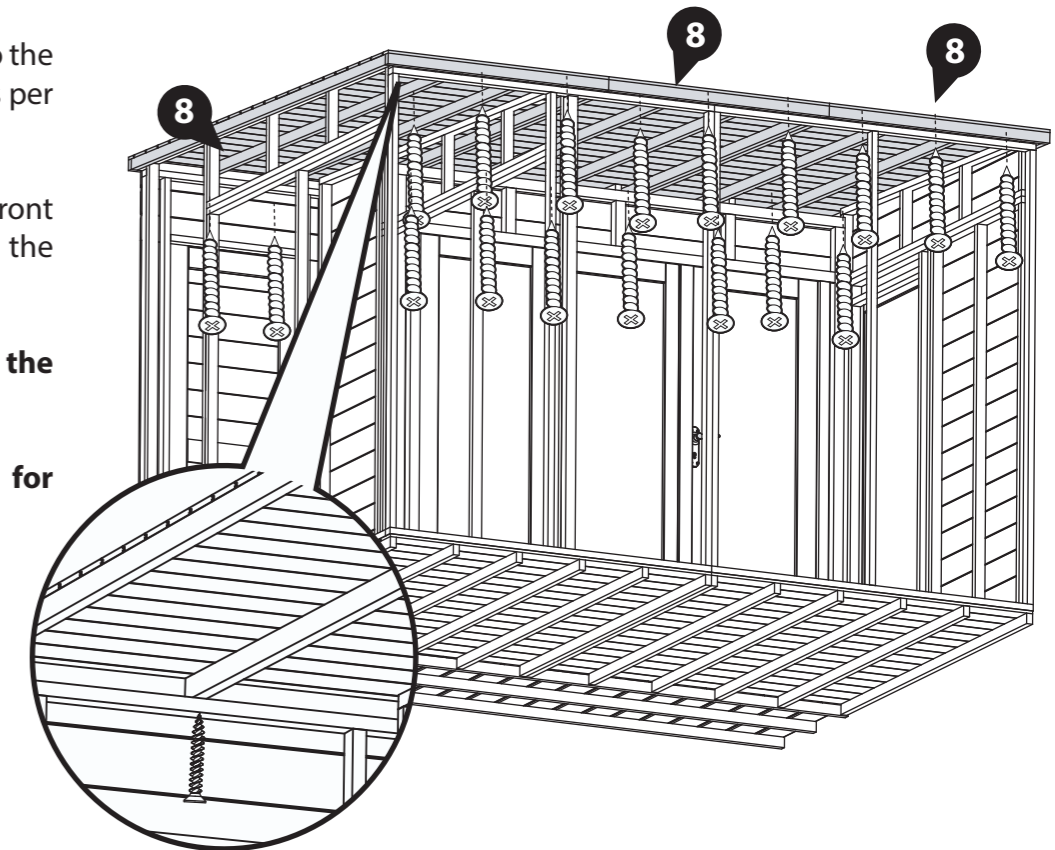

IMPORTANT: Pre-drill before fixing screws.

Step 22

Parts Needed - No. 11 QTY 1

Place the Under Roof (No. 11) into position, making sure it is flush to the Door panel and Storage section.

Fix in place making sure to screw through the Roof framing.

14x30mm Screws

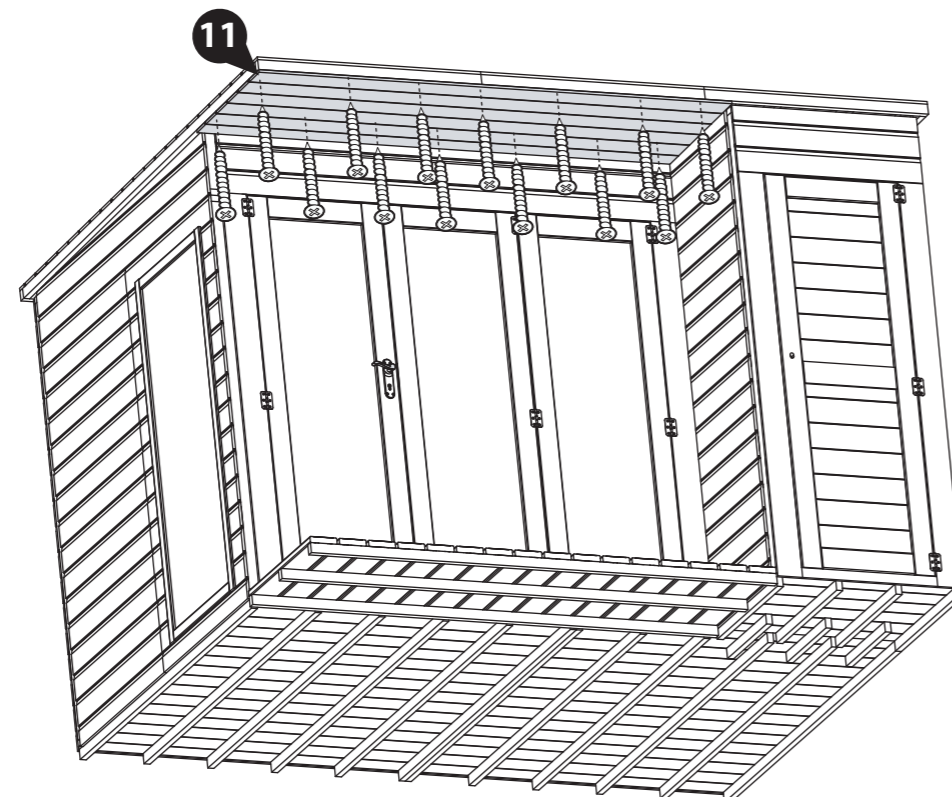

IMPORTANT: Pre-drill before fixing screws.

Step 24

Once the Roof is aligned and secure the Floor can be fixed into position.

Fix the building into place by screwing through the panel into the floor making sure to screw into the floor bearers.

External panels not shown for illustrative purposes.

34x50mm Screws

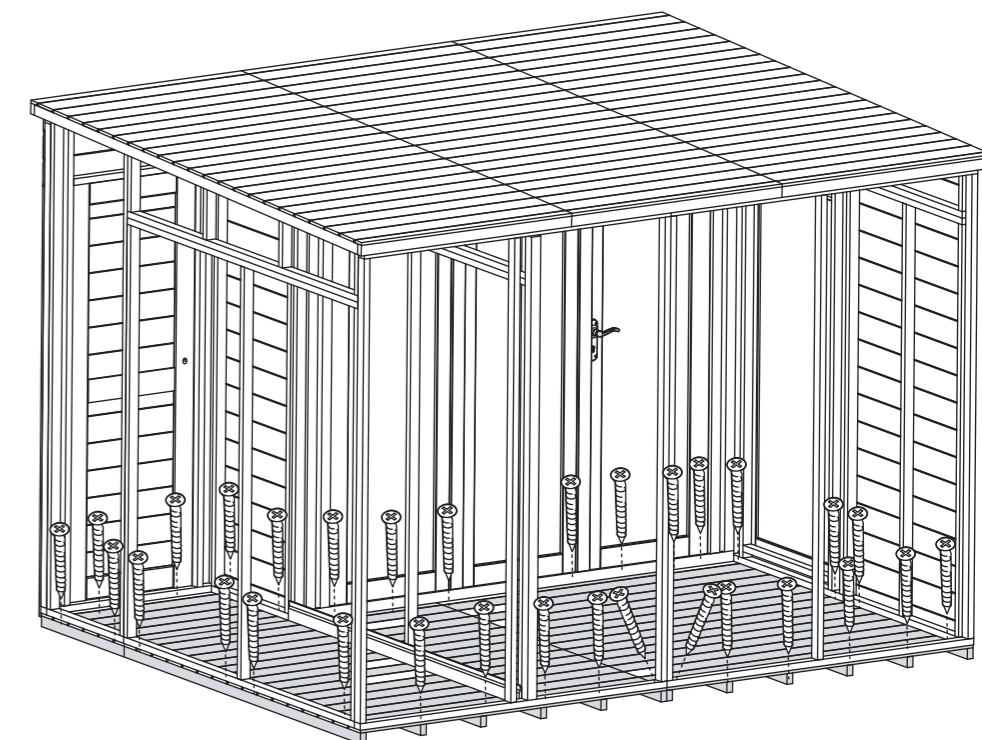
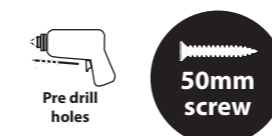

IMPORTANT: Pre-drill before fixing screws.

Step 25

Parts Needed - No. 43
No. 44
No. 46 QTY 1

a Cut the Sand Capping Felt (**No. 43**) into one sheet measuring: **3100mm (L) x 300mm (W)**

Cut the Sand Felt (**No. 44**) into three sheets measuring: **3100mm (L) x 1000mm (W)**.

Lay the sheets onto the roof in the order shown, starting with the Capping Felt (**No.43**) as the first sheet laid, then the remaining three sheets (**No. 44**)

Ensure the sheets overhang each side by 50mm and overlap each other by 100mm.

There may be a larger overhang around the building than suggested, if so, excess felt can be cut off from around the building after fitting is complete.

b To ensure a complete bond between the sheets, apply the Butyl (**No. 46**) between each overlapping layer, as shown in the image. Ensure to apply the Butyl using a sealant application gun and in a 'wiggly' line for the best finish. Once applied, compact the layers to seal.

At each corner, fold the felt over each other so they sit on the front and backs of the building, as shown.

Secure the felt in place by hammering felt tacks into the overlapping layers, the front, back and sides of the building at 100mm intervals, as shown.

150 x Felt Tacks

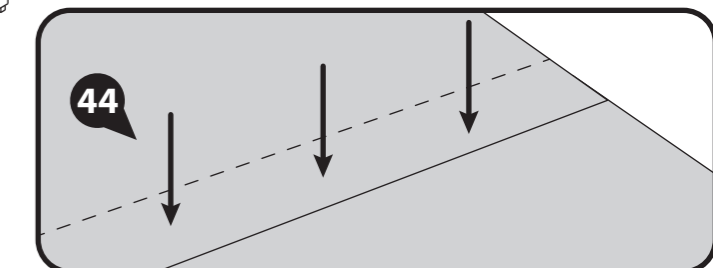
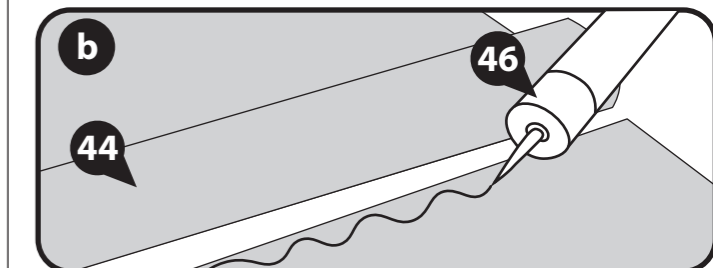
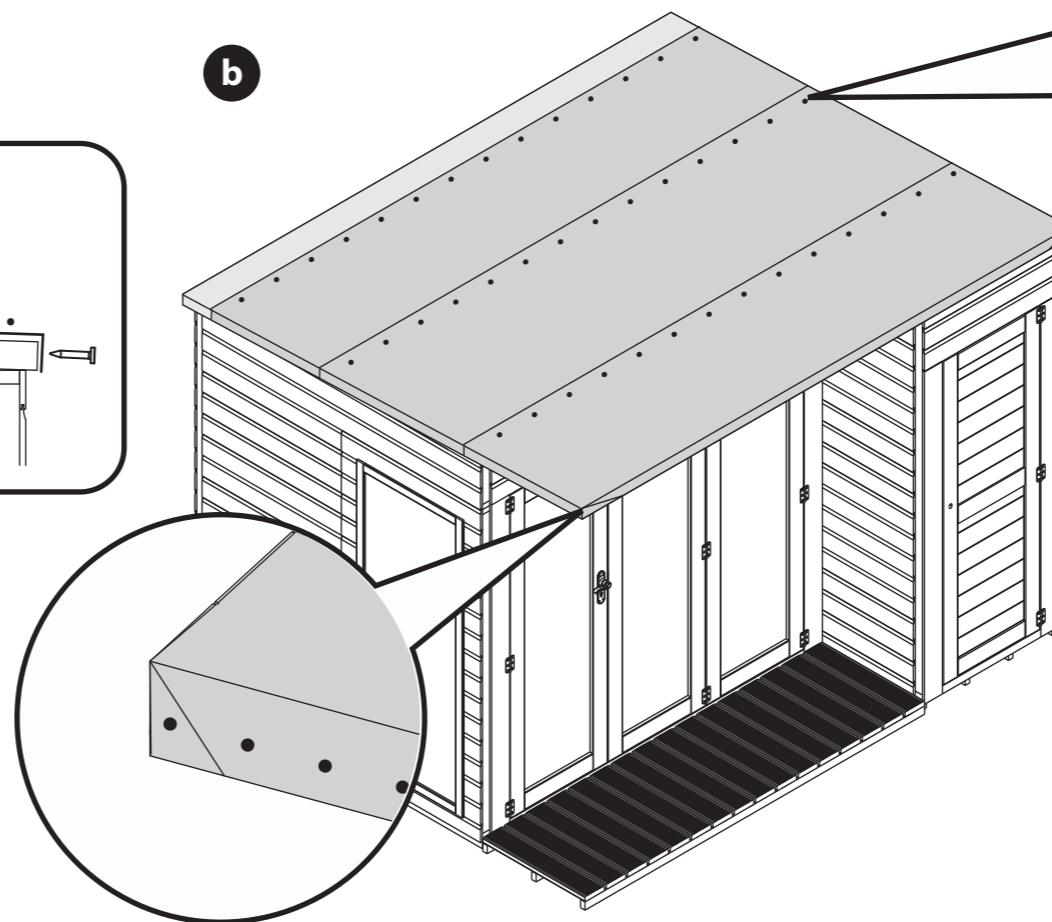
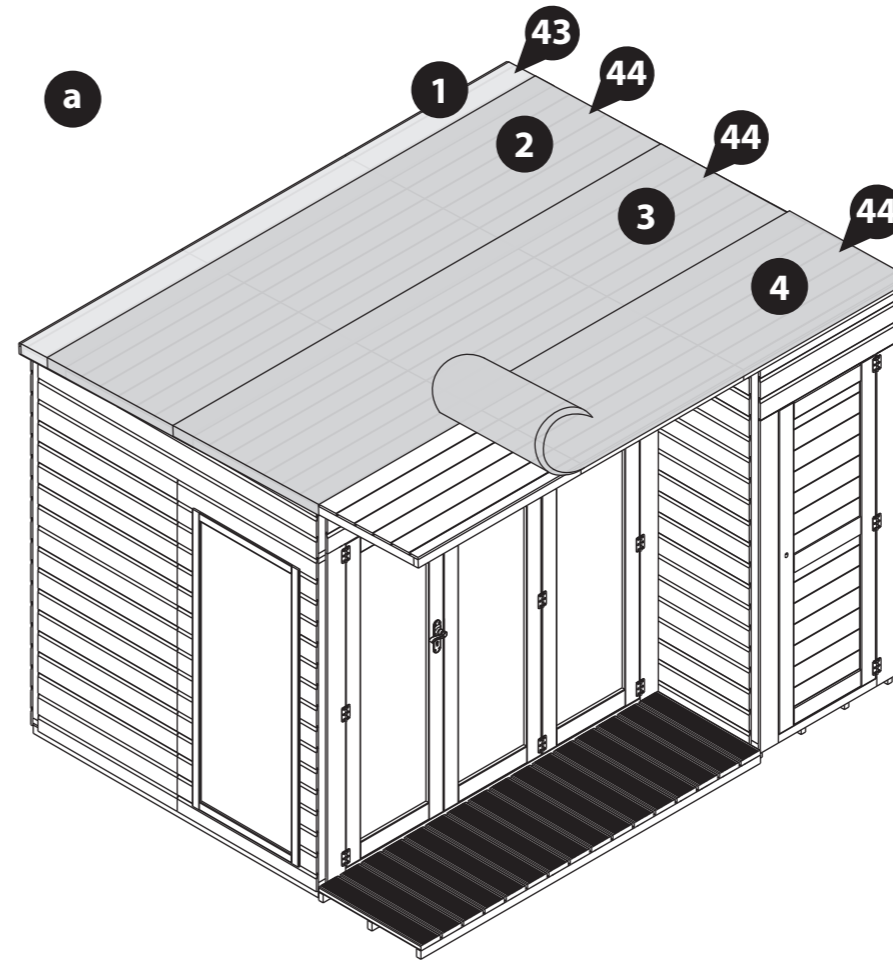
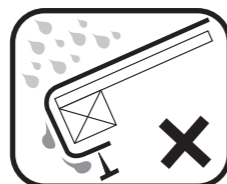
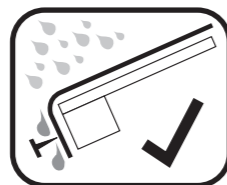
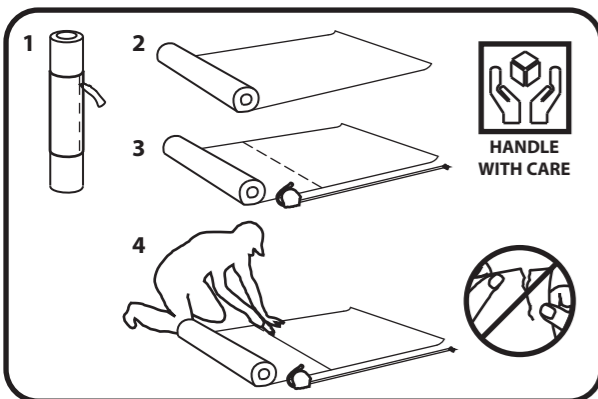
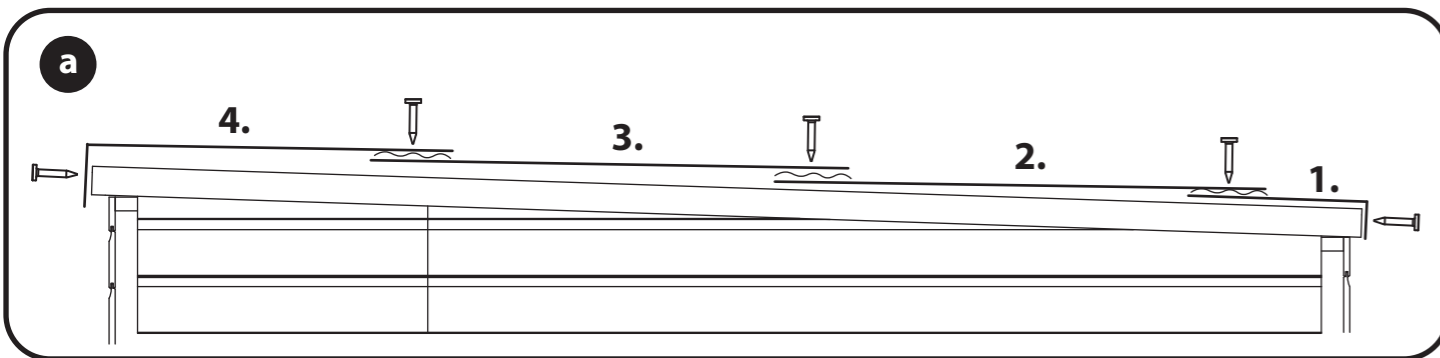

Step 26

Parts Needed - No. 45

No. 46 QTY 1

a Cut the Green Felt (No. 45) into three sheets measuring: **3100mm (L) x 1000mm (W)**.

Lay the sheets onto the roof in the order shown. Ensure the sheets overhang each side by 50mm and overlap each other by 100mm.

****Make sure that where the Green felt layers overlap is offset to the previously laid Sand felt, as shown in the diagram. This will ensure the felt can be secured correctly and allows water to drain off efficiently.****

There may be a larger overhang around the building than suggested, if so, excess felt can be cut off from around the building after fitting is complete.

b To ensure a complete bond between the sheets, apply the Butyl (No. 46) between each overlapping layer, as shown in the image. Ensure to apply the Butyl using a sealant application gun and in a 'wiggly' line for the best finish. Once applied, compact the layers to seal.

At each corner, fold the felt over each other so they sit on the sides of the building, as shown. Ensure these corners sit on the opposite sides to the sand felt, as suggested.

Secure the felt in place by hammering felt tacks into the overlapping layers, the front, back and sides of the building at 100mm intervals, as shown. Ensure to stagger the tacks on the sides, front and back to avoid colliding with the layers below.

150 x Felt Tacks

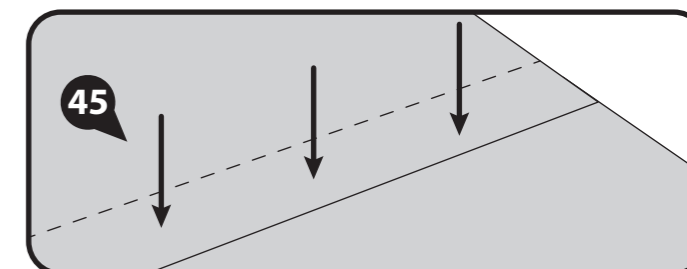
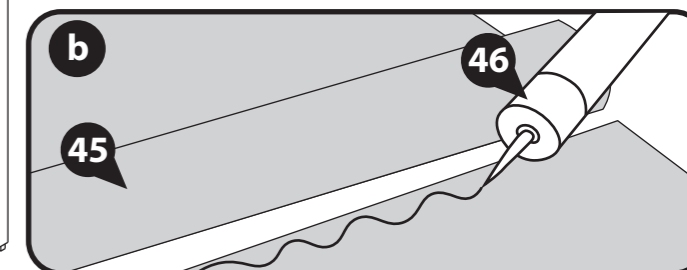
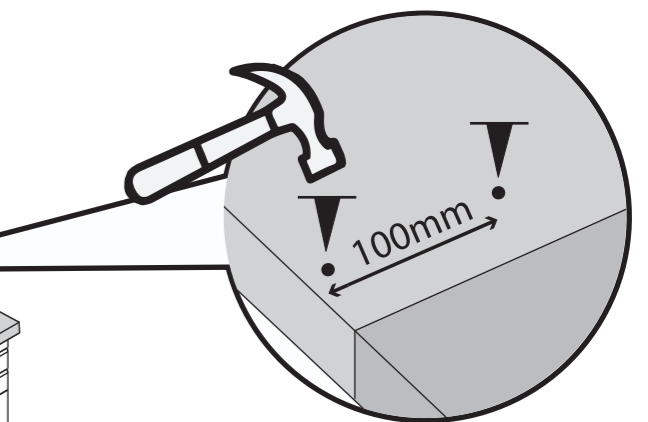
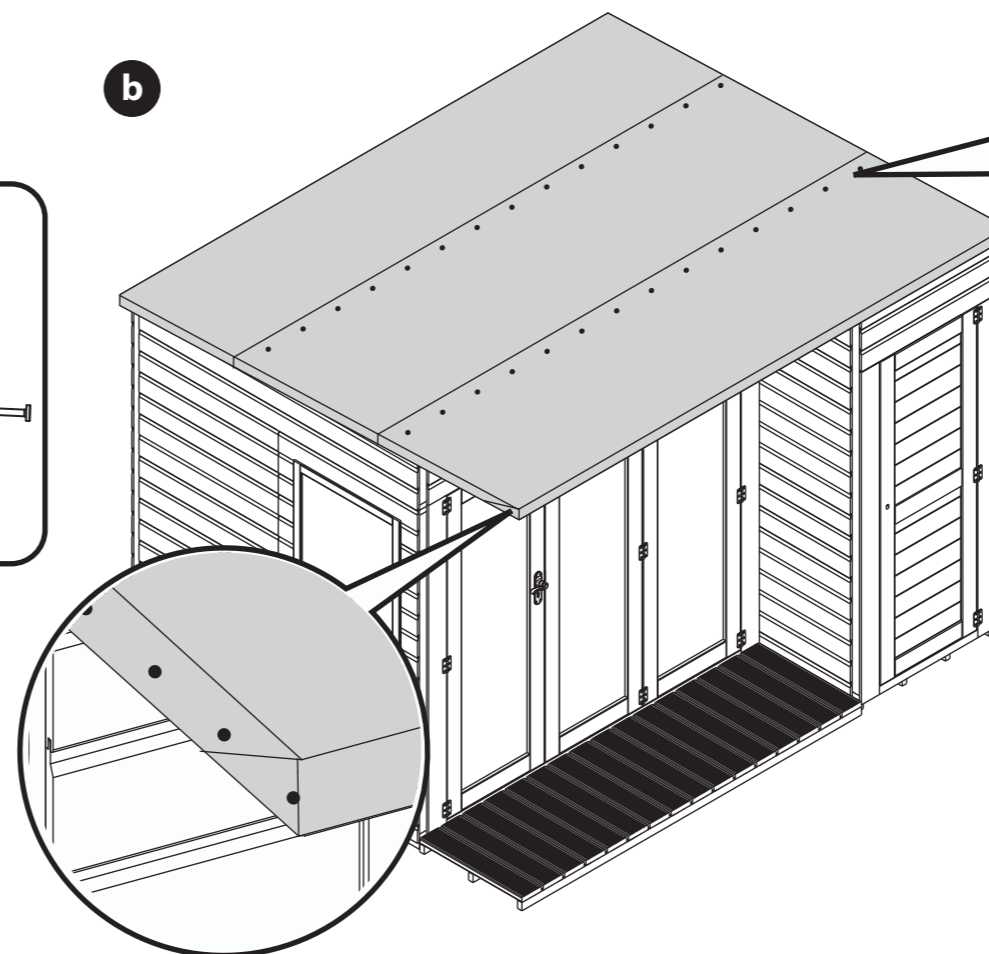
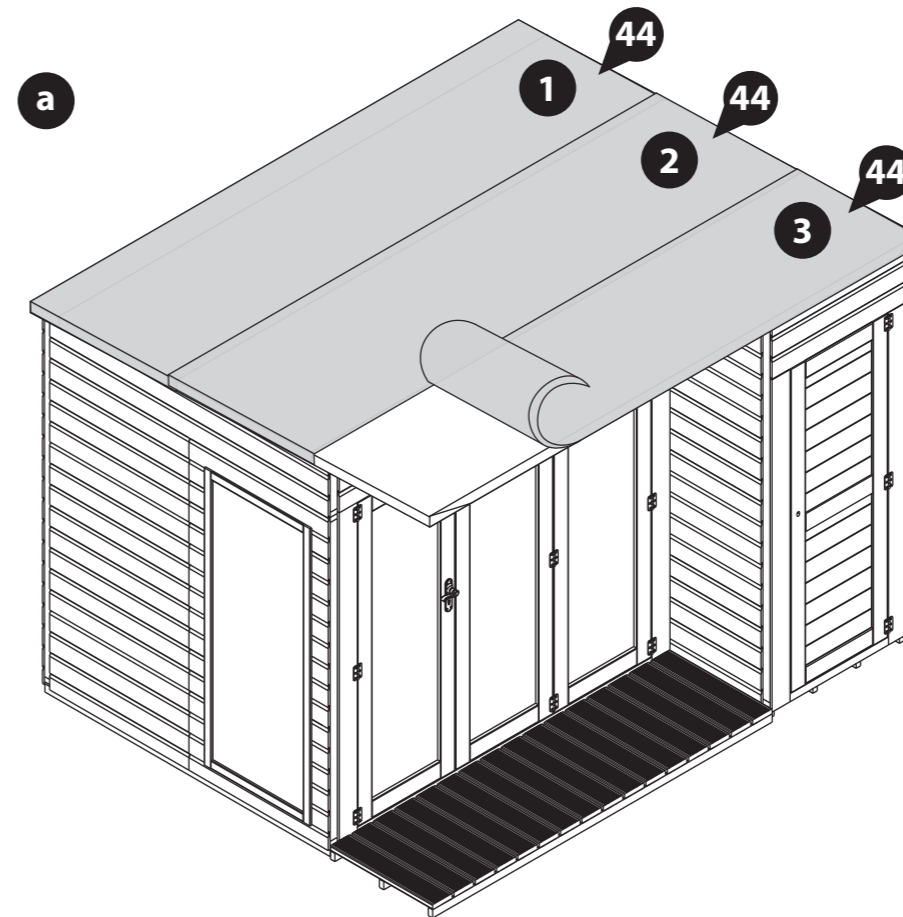
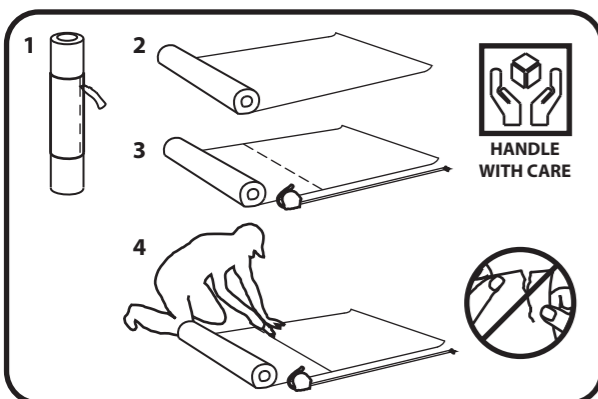
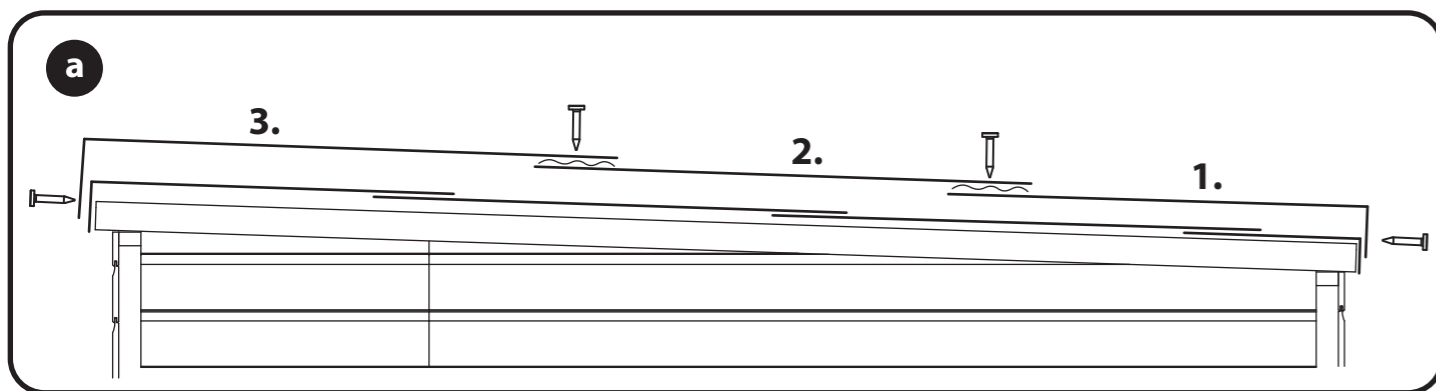

Step 27

Parts Needed - No. 29 QTY 4

Measure the distance from the front to the back of the building using a tape measure, as shown.

Half this measurement and mark the new total onto four Side Fascias (**No. 29**) and cut to size.

Locate the cut down Fascias onto the sides of the building, ensuring to trap the felt between the Fascias and the roof.

Secure the Fascias in place using 3x30mm screws per Fascia.

12x30mm Screws



IMPORTANT: Pre-drill before fixing screws.

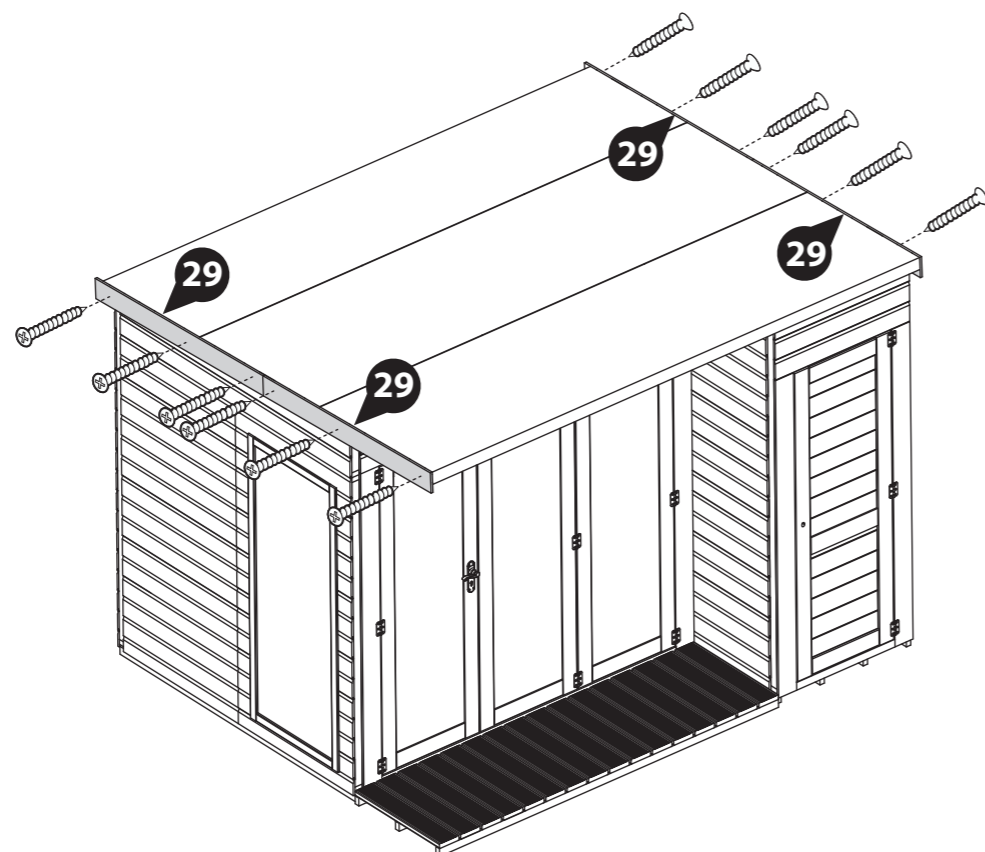
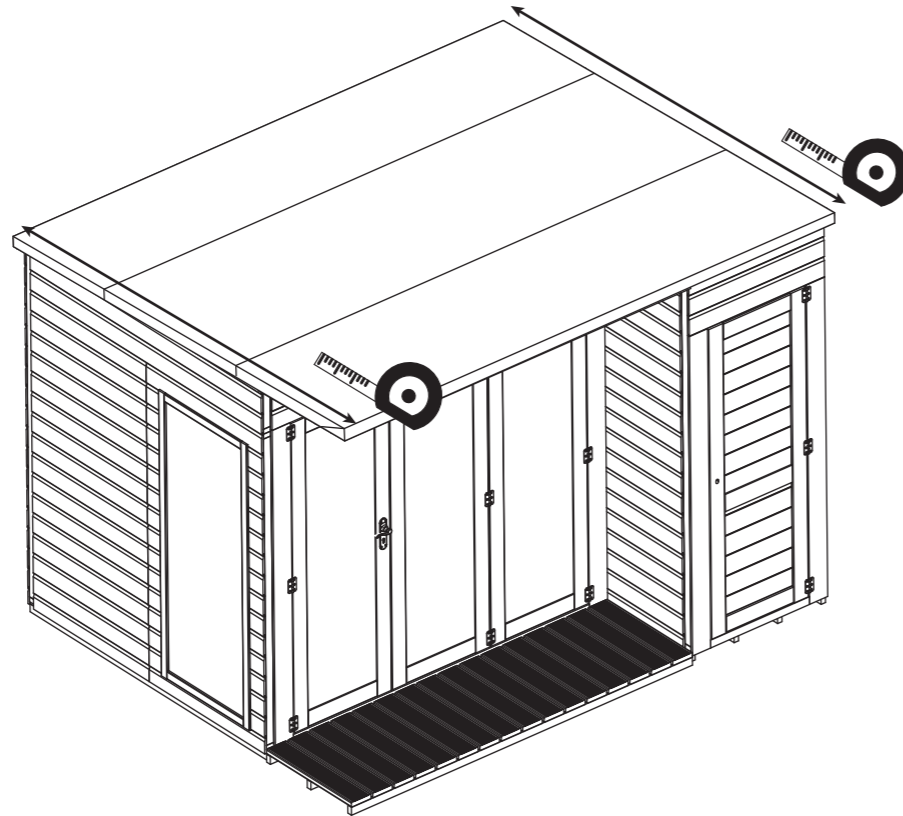

Step 28

Parts Needed - No. 30 QTY 2

Measure the distance across the front of the building using a tape measure, as shown.

Half this measurement and mark the new total onto two Front Fascias (**No. 30**) and cut to size.

Locate the cut down Fascias onto the front of the building, ensuring to trap the felt between the Fascias and the roof.

Secure the Fascias in place using 3x30mm screws per Fascia.

6x30mm Screws

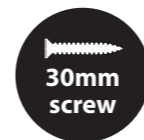

IMPORTANT: Pre-drill before fixing screws.

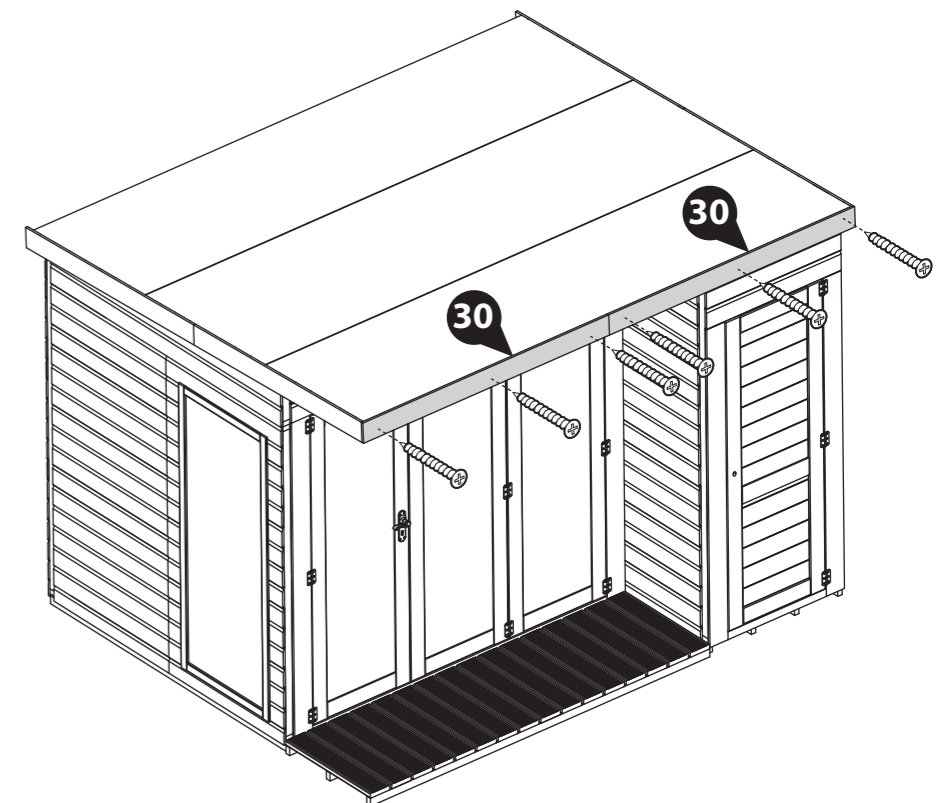
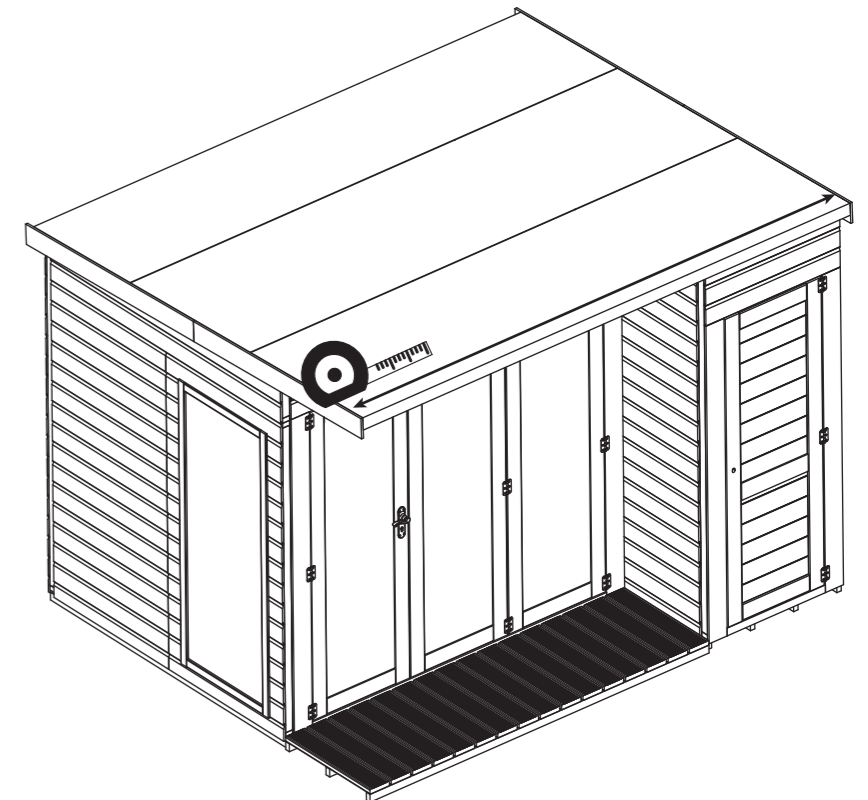

Step 29

Parts Needed - No. 23 QTY 1
 No. 24 QTY 2
 No. 25 QTY 1
 No. 26 QTY 1
 No. 27 QTY 1
 No. 28 QTY 2

Fix the Cover Trims (No. 23, No. 24, No. 25, No. 26, No. 27 and No. 28) into position over each corner and panel join, as shown.

Fix into position using 3x30mm screws per trim.

24x30mm Screws

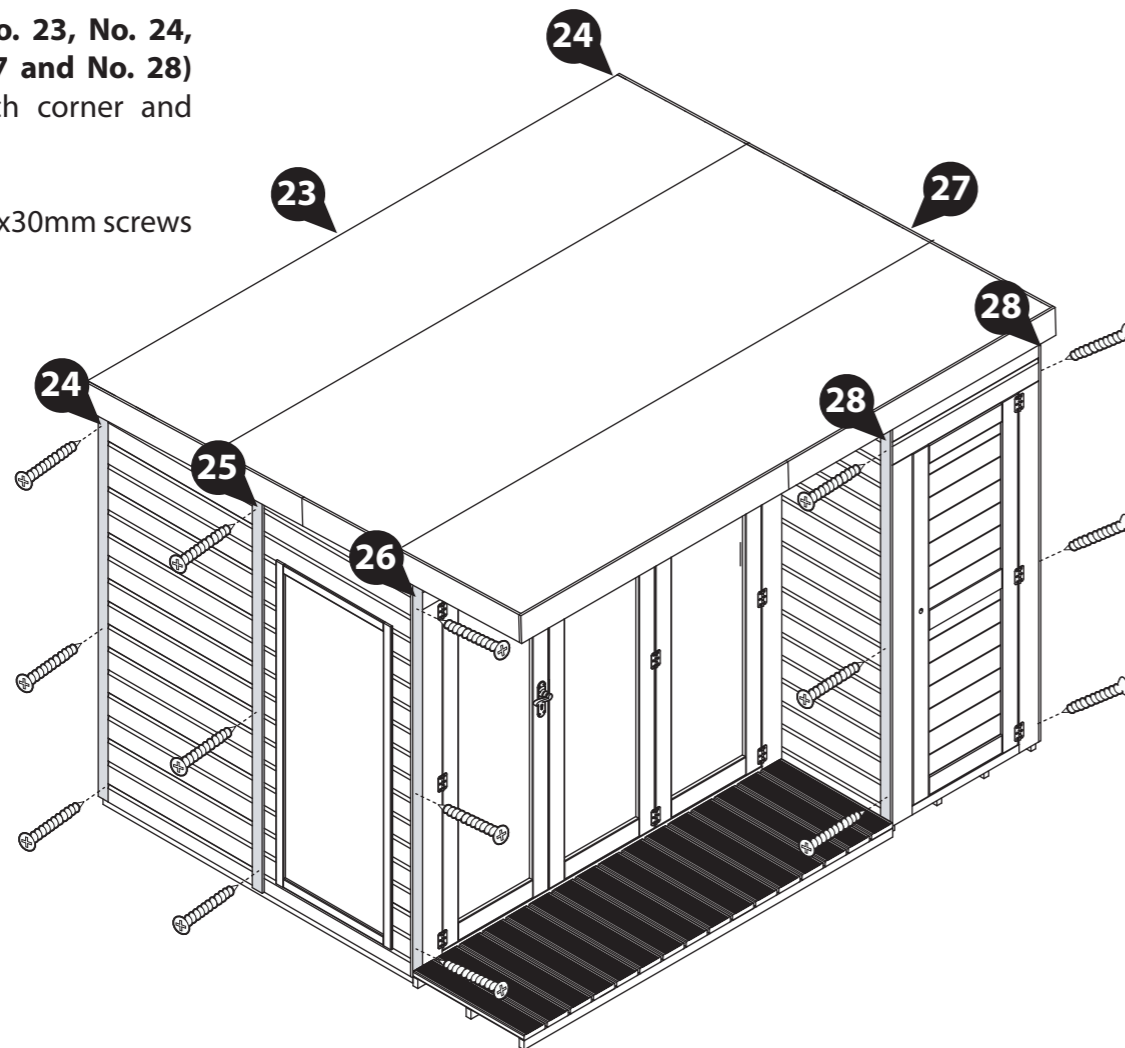

IMPORTANT: Pre-drill before fixing screws.

Step 30

Parts Needed - No. 36 QTY 2
 No. 37 QTY 1

On the inside of the Storage Door, locate one Lock Block (No. 36) onto either side of the centre framing of the Door, above and below the key hole, as shown. Secure each block in place using 2x40mm screws.

Position the Press Lock (No. 37) on top of the Blocks, making sure to align the key hole of the lock to the key hole of the door, as shown. Secure in place using 4x40mm screws.

8x40mm Screws

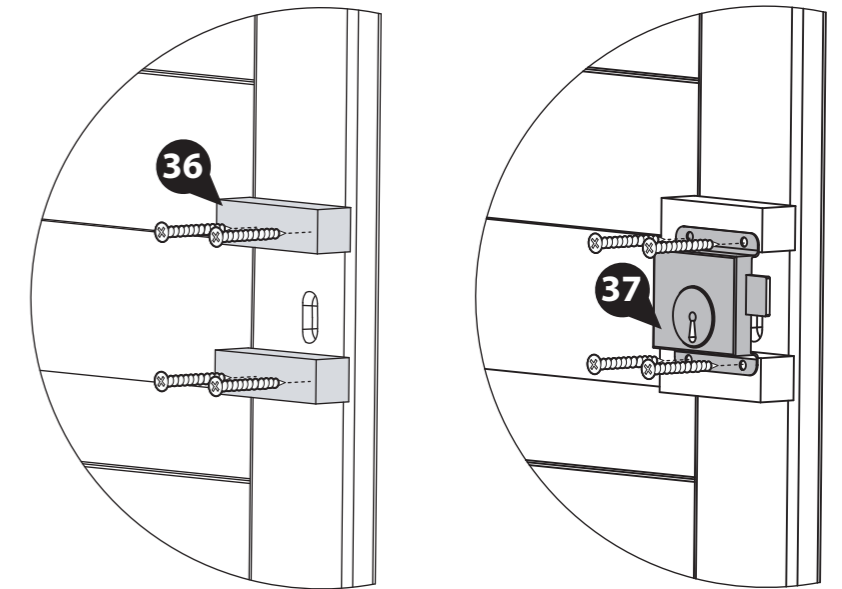
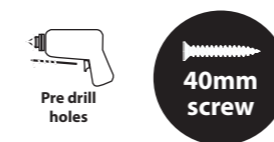

IMPORTANT: Pre-drill before fixing screws.

Step 31

Parts Needed - No. 33 QTY 1
 No. 34 QTY 1

On the Storage Door, secure the Handle (No. 34) in place using 2x45mm bolts.

On the inside of the Storage Door Panel, locate the Door Stop (No. 33) to bottom right corner. Secure in place using 3x30mm screws.

2x45mm Bolt
 3x30mm Screws

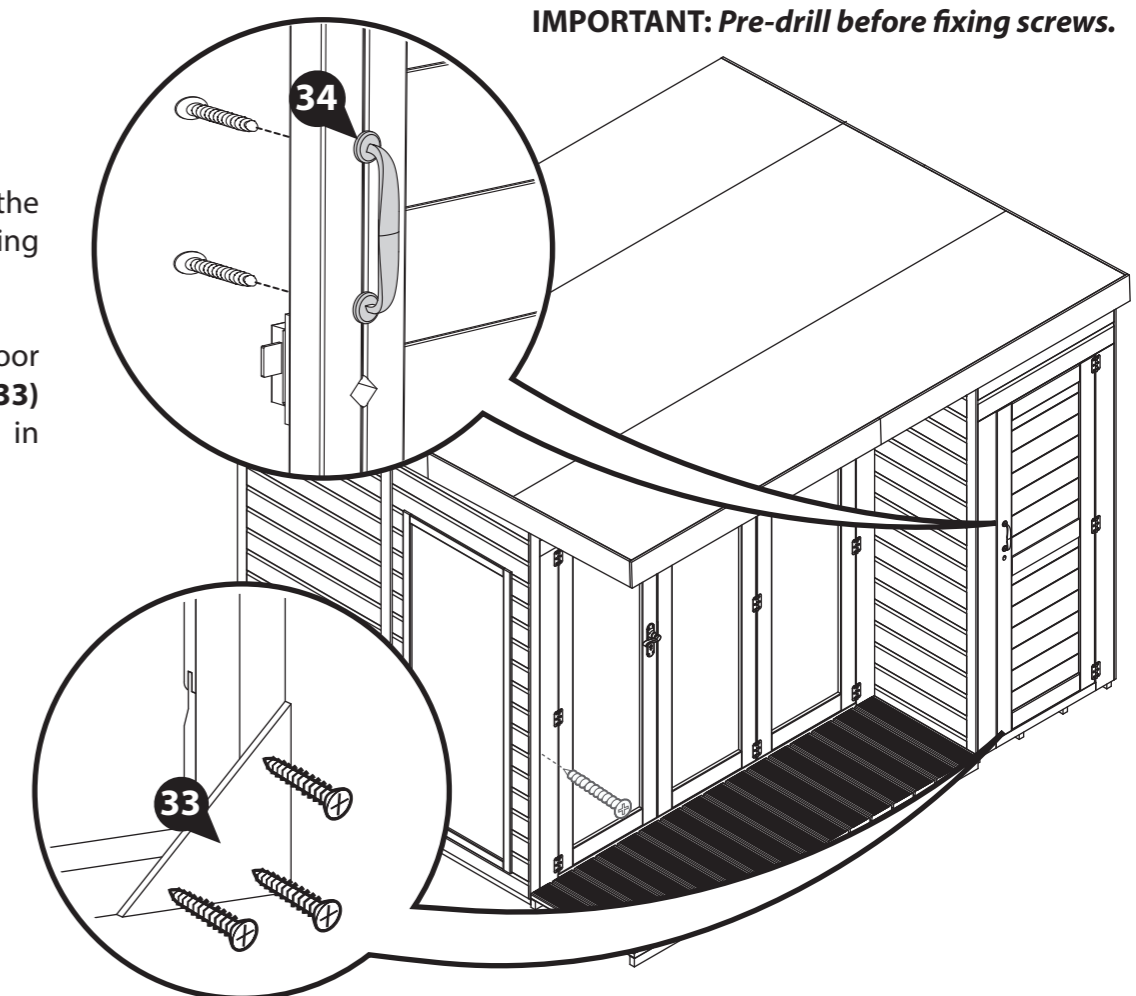
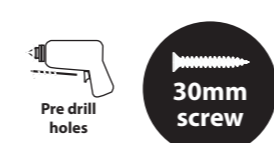

IMPORTANT: Pre-drill before fixing screws.

Step 32

Parts Needed - No. 42 QTY 4

Locate a Turn Button (No. 42) to the top and bottom of the Storage Door Panel. Secure in place using 1x30mm screw per turn button, ensuring that the screws go through into the Door Panel framing.

Position two further Turn Buttons to the top and bottom of the secondary Door. Fix in place using 1x30mm screw per turn button.

These Turn Buttons help to keep your doors straight during high and low levels of moisture content in the air.

4x30mm Screws



30mm screw

IMPORTANT: Pre-drill before fixing screws.

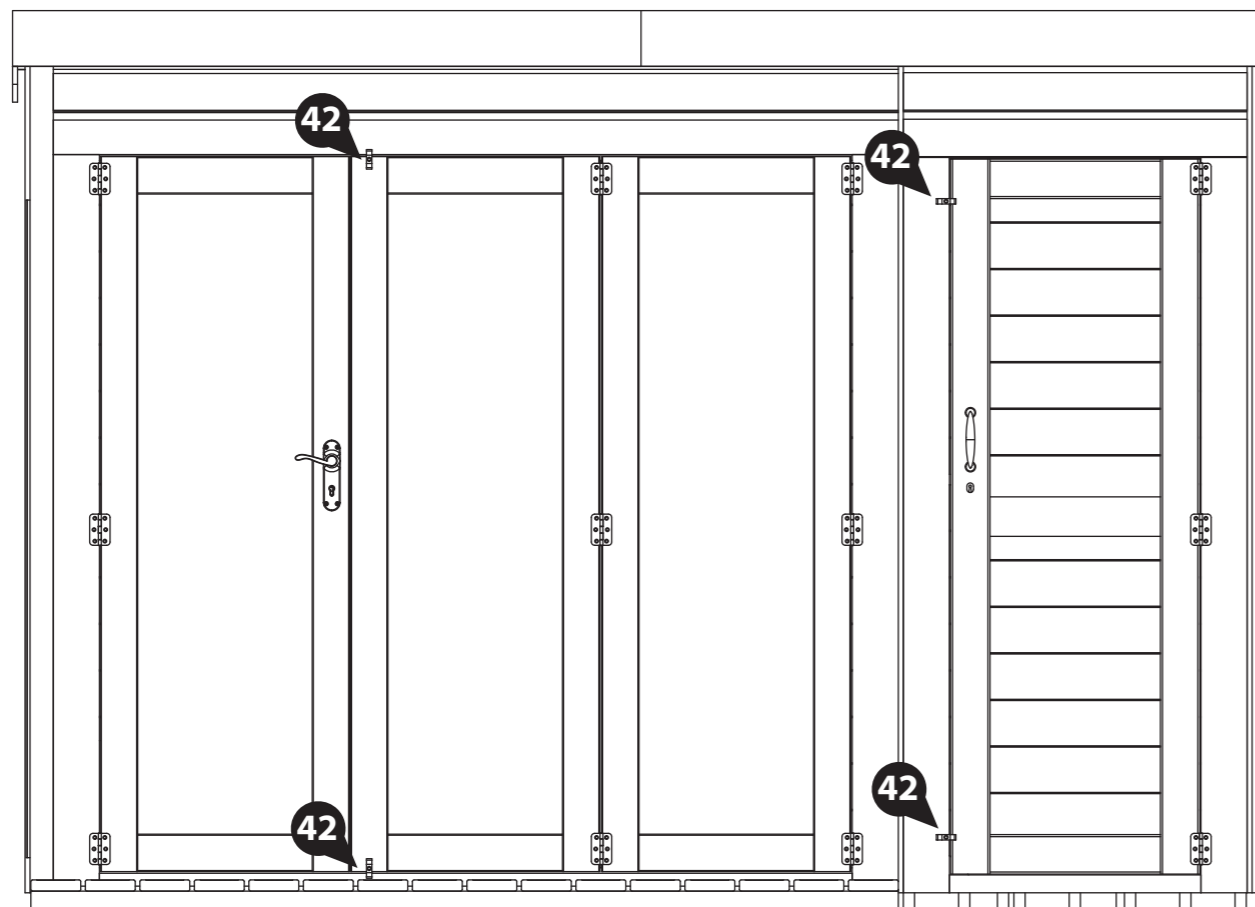
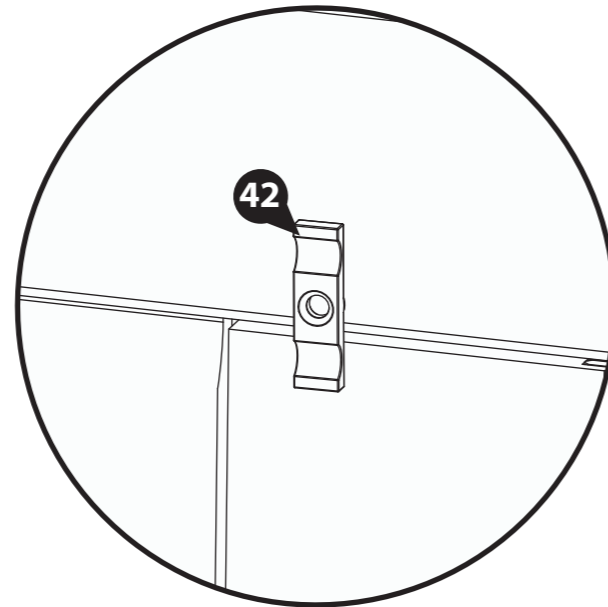

Step 33

Once constructed, apply a preserving treatment and a waterproofing treatment to your garden building as soon as possible. This will help to protect your building and prevent decay.

See page 18 for a full guide and instructions.

Once fully treated, score around the protective covers on the glazing and carefully peel the coverings back.



Apply treatment.



Score and peel.

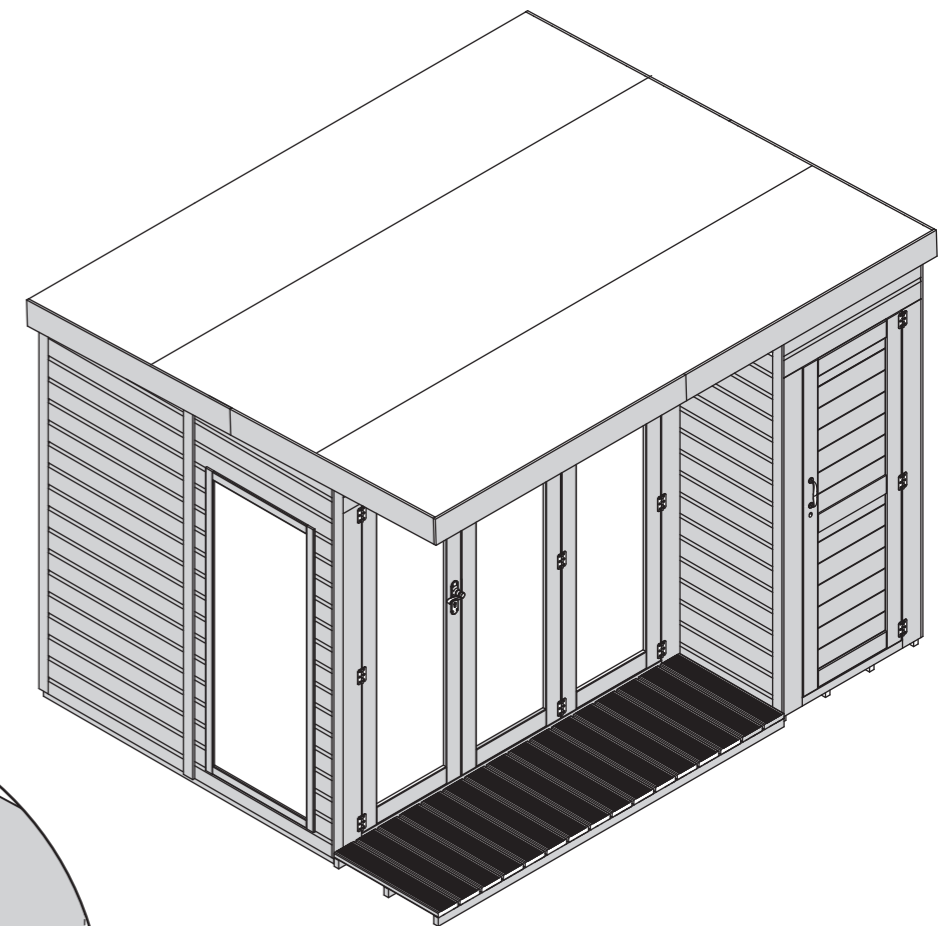
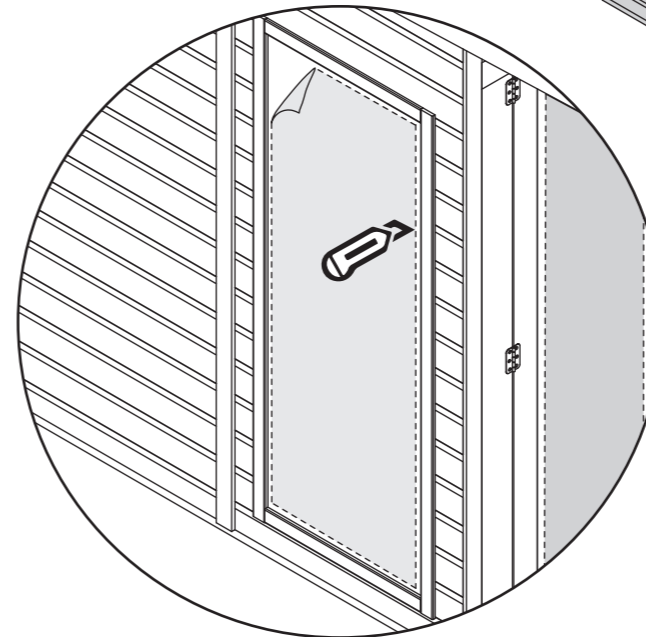

LEAVE US A REVIEW...



Want to share your experience with us?
Leave us a review on Feefo, TrustPilot or Google.

Your reviews help other people find and trust our business, as well as helping to play an important role in our growth and improvement!

TREATING YOUR GARDEN BUILDING

Preservation of wood that's outdoors is vital. A little early care will help protect your garden building, improve its appearance and ensure maximum longevity. Insects, moisture, salt, and changing weather can have dramatic effects on the stability and appearance of your garden building. Once your building is installed, you've checked it over and you're happy with it, you can take a few basic precautions to prepare it for the elements. Treating your garden building helps prevent decay and, by repelling water, discourages the growth of moulds and fungi that could jeopardise the structural integrity of the wood.

Dip Treated buildings - Require a preservative treatment to protect against rot and decay and a waterproof treatment to prevent water ingress
Pressure Treated buildings - Require a waterproof treatment to prevent water ingress
Log Cabins/Insulated Garden Rooms - Are supplied untreated and require a preservative and waterproofing treatment.



ANY QUESTIONS?
Scan the QR code to contact us via our customer portal.

To apply a preservative and water proofing treatment (pressure treated products do not require a preserver), follow the manufacturer's instructions but in principle, stick to the following steps:

- ✓ Weather permitting, ensure to treat your garden building within 14 days of installation.
- ✓ Wear latex or rubber gloves, eye protection and (if spraying) a mask.
- ✓ Prepare the wood, by sanding down any ridges or inconsistencies in the wood, smoothing out knots and end-cuts.
- ✓ Choose a dry day to treat your garden building. If you're spraying rather than brushing paint on, avoid a windy day.
- ✓ Be sure you can safely reach all the sections you need to paint - and if you need a ladder, make sure it's safely positioned before climbing. Lay dust sheets around to avoid paint splatters on your base or surrounding plants.

- ✓ Tape around windowpanes to avoid smears when you're painting the frames.
- ✓ Keep pets and small children out of the way. The last thing you want is to have fur on your garden building paint, or little painted footprints all over your garden and home.
- ✓ Fill any gaps in the building's body with caulk or wood filler to prevent water and draughts getting in. Silicone based caulk is flexible and will move with the timber when temperature and humidity change. Allow to dry completely before treating. A handy tip for finding gaps is to go into your garden building and look for light leaking through joins and frames. If light gets in, then so will water.
- ✓ Liberally apply at least two coats of the treatment products with a brush or spray, taking care to allow the first coat to completely dry before applying the second.
- ✓ Make sure the solution permeates the whole of the surface area, especially around natural cracks, end cuts and nail/screw holes.



APPLY WOOD TREATMENT
IMMEDIATELY
AFTER ASSEMBLY



1 Perimeter

Check around the perimeter of your product to ensure there are not trees or plants that are in contact with or overhanging the building. This can affect airflow and overhanging trees, or branches can damage the roof, it is advised to keep plants at a distance.

2 Repair

Inspect the interior and exterior of the product to look for splits, cracks, and holes. Although this is a natural occurrence it can be prevented. A wood filler can be used to close the splits, cracks, and holes.

3 Roof

Check your roof regularly for tears, splits, damaged wood and fallen debris. If you notice any of this immediate repair is critical.

4 Doors & Windows

Expansion and contraction can cause doors and windows to stick or become difficult to open. Small adjustments to the hinge position can be made to the doors and windows to allow free movement.

5 Oil

Hinges can seize up over time, apply lubricant to the hinges and locks annually.

6 Screws & Bolts

It is advised to check all screws and bolts and tighten any loose you might find. For log cabins specifically the storm braces will require loosening. During humidity and temperature changes (seasons) to allow expansion and contraction to prevent gaping, twisting, popping, and warping.

7 Wash

At least once a year, give the outside of your building a good wash, to remove cobwebs, leaves, or any other dirt that may accumulate on the exterior.

8 Airing

Airing your product regularly prevents the build up of condensation which can cause the timber to warp, bow, boards to pop, distortion, rot and mould. Condensation can build up over time or daily, it is caused by a rise and fall in temperature.

Excessive moisture levels within your building can cause water to collect on the roofs, walls and floors internally. Leaving doors and windows open regularly can help combat the natural moisture build up.

9 Clean & Tidy

It is good practice to clean the inside and outside of your product regularly. Clear out the contents, sweep the floor, remove dirt and cobwebs. Check for areas of damp and investigate the cause to remove and prevent future occurrences. Check the ground around your product for build up of debris such as leaves, remove and ensure there is clear ventilation underneath the floor.

Additional Playhouse Maintenance:

It is recommended that the following checks and maintenance are carried out at the beginning of each season as well as at regular intervals during the usage season.

- Check all nuts /bolts/ screws for tightness and tighten when required.
- Check for movement / opening of wood giving rise to protrusion of nail heads and tips.
- Check hinges.
- Replace defective parts in accordance with the manufacturers instructions.
- Check any crossbeams, suspensions and anchors.
- If a swing is included; check the swing seat, chains and ropes.

IF THESE CHECKS ARE NOT CARRIED OUT THE ACTIVITY TOY COULD BECOME A HAZARD

All our garden buildings have been designed and manufactured with care and attention to be the perfect addition to your outdoor space. To ensure you do get the best out of your new garden building and to increase the longevity we advise that you follow the product instructions and our manufacturer's recommendations as detailed below. Thank you for choosing a Mercia Garden product!

1 Choosing the most suitable location for your garden building...

A minimum of 60cm should be left around the perimeter of your garden building to allow access for maintenance, annual treatment and to allow air flow around the building.

Where possible you should avoid placing your garden building underneath large trees to prevent the tree causing damage to the building.

2 Preparing the base for your garden building...

All our buildings must be built on a firm, level base to ensure the longevity of the building and prevent the wood from distorting. We recommend either concrete, concrete slabs or a wooden base, such as our 'Portabase'.

The base should be slightly smaller than the external measurement of the building, i.e. the cladding should overlap the base, creating a run off for water and preventing water from pooling underneath the building.

We also recommend that the floor of the garden building is a minimum of 25mm above the surrounding ground level to avoid flooding.

3 After installation...

Once your garden building has been installed, it will need to be treated within 14 days (weather permitting) and annually to prevent the timber from deteriorating and to waterproof it. This is required to maintain the anti-rot guarantee.

Dip Treated buildings - Require a preservative treatment to protect against rot and decay and a waterproof treatment to prevent water ingress.

Pressure Treated buildings - Require a waterproof treatment to prevent water ingress.

Log Cabins/Insulated Garden Rooms - Are supplied untreated and require a preservative and waterproofing treatment.

We also recommend using a silicon sealant on the inside and outside of the windows as soon as possible after assembly and treatment to fully seal the windows.

Roofing felt/covering should be checked annually and replaced or fixed accordingly.

4 General maintenance and wood characteristics

As wood is a natural material it may be affected by the following:

Shrinkage and warping - The timber used in the construction of your garden building will have retained some of its natural moisture content. The moisture content of the timber will vary, depending upon prevailing environmental conditions, which will result in the components either naturally expanding or contracting. As the components dry out, shrinkage may occur. A good waterproofing treatment from the start is the best protection to minimise the effect of moisture loss/intake.

In extended periods of very warm weather getting some moisture to the building will help the overall balance. You can do this by spraying it down lightly with a garden hose. In contrast, after snow fall try to remove the snow as best as possible from the roof to prevent moisture intake and to remove the extra weight.

Top tip - using a garden brush will help you to reach the highest part of the building to remove snow and any debris left from bad weather.

Damp and mould - During the winter months, cold and damp conditions can result in an increased amount of moisture within your garden building, especially when used infrequently. Condensation can form on the timber and other items stored within your garden building. If left this moisture is likely to cause mould and mildew.

To prevent the build-up of moisture, we recommend leaving the door or windows of your building open from time to time, to allow the fresh air to circulate. We also advise against storing wet or damp items in your garden building as this will also increase the level of moisture in the building. If mould or mildew does start to form within your building we recommend using an anti-mould cleaner to remove it and to prevent it spreading, which if left untreated could permanently damage your garden building.

Splits, cracks and knots - You may notice small splits and cracks in some components or holes may appear where knots shrink and fall out. This will not affect the structure of your Garden building however, if you wish to fill them this can be easily done using any good quality wood filler.

Sap - is naturally occurring in wood and may appear in some boards of your garden building. If you wish to remove the sap, we advise waiting until it is dry and then using a sharp knife to carefully remove it. If the removal of the sap causes a hole in the timber, we recommend using a good quality wood filler to fill it.

For more handy hints and tips on how to care and maintain your garden building please refer to the MGP Customer Portal at www.mgplogistics.co.uk



Any further questions?

Contact our Customer Service Team via the MGP Customer Portal at: www.mgplogistics.co.uk

1

Manufacturer's Warranty

All Mercia Garden Products are supplied with a 1 year warranty on all parts against manufacturing defects.

This warranty does not cover movement, warping or splitting of timber products over time.

This warranty will be voided if any of the following occur:

1. The building has been customised or modified/adapted in any way.
2. The person claiming is not the original purchaser of the building.
3. Any damage has been caused by or as a result of misuse.
4. The building has not been maintained and cared for in accordance to our advisories and manufacturer's recommendations.
5. The building has not been treated annually or as per the manufacturer's recommendations, please ensure receipts are kept to validate this claim.
6. The building has not been erected, fitted or installed as per the supplier instructions.
7. The building has not been erected on a suitable sized firm flat, solid level concrete/slab base or placed on pressure treated bearers.
8. The building is or has been placed with 2 feet (600mm) of any obstructions (walls, trees, plants, fences etc.) which can allow moisture to penetrate the timber.
9. The roofing felt has been incorrectly fitted or damaged, allowing water ingress, or has not been properly maintained.
10. Any windows and joints have not been sealed, inside and out, with silicone or other watertight sealant.
11. Any timber has been cut, pierced or drilled without subsequent application of approved cut-end treatment.

REGISTER FOR YOUR
10 YEAR
ANTI-ROT
GUARANTEE TODAY



www.mgplogistics.co.uk

2

Anti-rot Guarantee

Mercia Garden Products offer a 10 year anti-rot guarantee on all dip treated (a preparatory treatment) and 15 years on all pressure treated products. This guarantee covers solid timber against rot, decay, blue stain and insect attacks.

To validate the guarantee, the building must be treated (as detailed within manufacturer's recommendations) within 14 days (weather permitting) of assembly and annually thereafter.

This guarantee does not cover movement, warping or splitting of timber products over time.

This guarantee will be voided if any of the following occur:

1. The building has been customised or modified/adapted in any way.
2. The person claiming is not the original purchaser of the building.
3. Any damage is caused by or as a result of misuse.
4. The building has not been maintained and cared for in accordance to our advisories and manufacturer's recommendations.
5. The building has not been treated annually or as per the manufacturer's recommendations, please ensure receipts are kept to validate this claim.
6. The building has not been erected, fitted or installed as per the supplier instructions.
7. The building has not been erected on a suitable sized firm flat, solid level concrete/slab base or placed on pressure treated bearers.
8. The building is or has been placed with 600mm of any obstructions (walls, trees, plants, fences etc.) which can allow moisture to penetrate the timber.
9. The roofing felt has been incorrectly fitted or damaged allowing water ingress, or has not been properly maintained.
10. Any windows and joints have not been sealed, inside and out, with silicone or other watertight sealant.
11. Any timber has been cut, pierced or drilled without subsequent application of approved cut-end treatment.