

03DTSHCV1208HGD4MW-V1
DIP TREATED SHIPLAP CURVED 12FT X 8FT HALF GLAZED DOUBLE 4 MEDIUM WINDOWS.



x2 All buildings should be erected by two adults



Winter = High Moisture = Expansion
 Summer = Low Moisture = Contraction



2mm Drill bit

For ease of assembly, you **MUST** pilot drill all screw holes and ensure all screw heads are countersunk.



CAUTION
 Every effort has been made during the manufacturing process to eliminate the prospect of splinters on rough surfaces of the timber. You are strongly advised to wear gloves when working with or handling rough sawn timber.



For ease of assembly, you will need a tape measure to check dimensions of components.

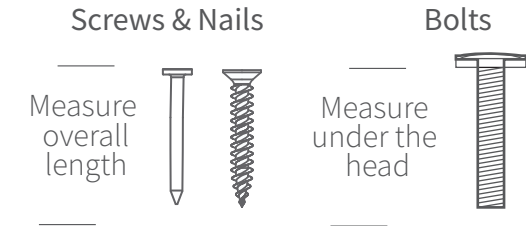

Screws & Nails
 Measure overall length

Bolts
 Measure under the head

To identify the fixings required for each step use a measuring tape.

****Protim Aquatan T5 (621)****

Your building has been dip treated with Aquatan.

Aquatan is a water-based concentrate which is diluted with water, the building as been treated by the correct application of Aquatan solution and then allowed to dry.

Aquatan is a decorative finish to colour the wood, which is applied industrially to timber fence panels and garden buildings.

Aquatan undiluted contains: boric acid, sodium hydroxide 32% solution, aqueous mixture of sodium dioctyl sulphosuccinat and alcohols: 2, 4, 6-trichlorophenol.

BEFORE YOU START PLEASE READ INSTRUCTIONS CAREFULLY

- Check the pack and make sure you have all the items listed in the parts list provided.
- When you are ready to start, make sure you have the right tools at hand (not supplied - see the equipment list on next page).
- Ensure there is plenty of space and a clean dry area for assembly.
- Ensure you have enough time to build the product to ensure the building is water tight.

LOCATION FOR YOUR GARDEN BUILDING

A minimum of 600mm should be left around the perimeter of your garden building to allow access for maintenance, annual treatment and to allow air flow around the building.

Where possible you should avoid placing your garden building underneath large trees to prevent the tree causing damage to the building.

TIMBER

As with all natural materials, timber can be affected during various weather conditions. For the duration of heavy or extended periods of rain, swelling of the wood panels may occur. Warping of the wood may also occur during excessive dry spells due to an interior moisture loss. Unfortunately, these processes cannot be avoided but can be helped. It is suggested that the outdoor building is sprayed with water during extended periods of warm sunshine and sheltered as much as possible during rain or snow.

Once your garden building has been installed it will need to be treated within 14 days (weather permitting) and annually to prevent the timber from deteriorating and to waterproof it. This is required to maintain the anti-rot guarantee.

- Dip Treated buildings - Require a preservative treatment to protect against rot and decay and a waterproof treatment to prevent water ingress
- Pressure Treated buildings - Require a waterproof treatment to prevent water ingress
- Log Cabins/Insulated Garden Rooms - Are supplied untreated and require a preservative and waterproofing treatment.

BUILDING A BASE

When thinking about where the building and where the base is going to be constructed: Ensure that there will be access to all sides for maintenance work and annual treatment.

Ensure the base is level and is built on firm ground, to prevent distortion. Refer to diagrams for the base dimensions, The base should be slightly smaller than the external measurement of the building, i.e. The cladding should overlap the base, creating a run off for water. It is also recommended that the floor be at least 25mm above the surrounding ground level to avoid flooding.

TYPES OF BASE

- Concrete 75mm laid on top of 75mm hard-core.
- Slabs laid on 50mm of sharp sand.
- Wooden base.

Whilst all products manufactured are made to the highest standards of safety and in the case of children's products independently tested to EN71 level, we cannot accept responsibility for your safety whilst erecting or using this product.

REGISTER FOR YOUR ANTI-ROT GUARANTEE TODAY

PLEASE SCAN HERE:

In all instances for assistance with your product, please contact us via our customer portal: <https://www.mgplogistics.co.uk/>.

Mercia Garden Products Limited,
 Sutton On Trent,
 Newark,
 Nottinghamshire,
 NG23 6QN

TO DO LIST

- Find a suitable location to build *(see front cover for further information).*
- Build a base *(see front cover for further information).*
- Check the base is flat, level, clear of debris and has 60cm clearance on all sides.
- Check you have the required equipment.
- Check you have all the product items listed *(if you have missing or damaged parts please contact the customer services department, see front cover for contact details).*
- Install the product as per the step by step instructions within this pack.
- Prepare the product ready for treatment.
- Apply a preserving and a waterproofing treatment within 14 days *(weather permitting)* of installation *(pressure treated products do not require a preserver).*
- Register for your anti rot guarantee *(scan the QR below).*
- Tidy the build area and dispose of any remaining parts responsibly.
- Maintain your building *(see the manufacturers recommendations at the back of this pack).*

EQUIPMENT LIST

- Hammer
- Flat Head Screwdriver
- Drill
- Drill Bit Set
- Phillips and Slotted Bit Sets
- Tape Measure
- Hand Saw
- Spirit Level
- Ladders/Steps
- Stanley Knife/Cutting Tool
- Sand Paper
- Gloves
- Silicone (For Windows Only)
- Wood Filler (Optional)
- Timber Preservative Treatment *(not pressure treated products)*
- Timber Water Proofing Treatment
- Treatment Mixing Stick
- Paint Brush/Sprayer/Roller

NEED EXTRA SUPPORT

If you are unsure that your base preparation will be suitable, please contact us via our customer portal to discuss this further.

Alternatively, you can visit our website or MGP Logistics Online Portal for some further sheducation.

Website:

<https://www.merciagardenproducts.co.uk/sheducation>

MGP Logistics Online Portal:

<https://www.mgplogistics.co.uk/>

Here you will find plenty of useful information that'll help with most pre-installation and maintenance queries.

PLEASE SCAN HERE:



ANY QUESTIONS?

Scan the QR code to contact us via our customer portal.

NOTES

ACCESSING VIDEO GUIDES...

Some steps within this set of instructions come with an added video guide for your convenience. These can be accessed via the QR code and used to aid you in constructing that step. See below for how to use.

You can also find all the videos on our youtube channel:
<https://www.youtube.com/@merciagardenproducts8716/videos>

1. Find the QR code within the instruction step...

Step.....

Parts Needed- No. QTY 1
No. QTY 1
No. QTY 1



Within the instruction step, there will be an icon in the top right that has a QR code in. This is where the video can be accessed from.

Please note: not every step has a video guide.

2. Open camera app...

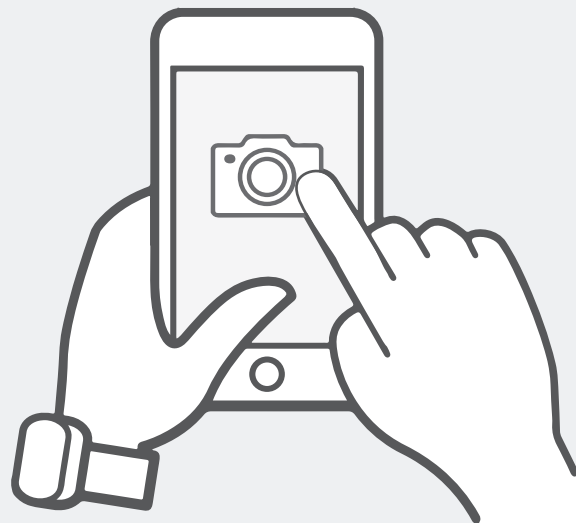

On your personal smart device (phone, tablet etc), open your camera app or QR code scanner app.

ACCESSING VIDEO GUIDES...

3. Scan QR code...



To scan the QR code, hold the camera over the QR code so that it can be seen on the screen. Once the QR code has been registered, follow the prompts on your device to open the video. (This will vary depending on your device.)

Please note: Ensure to use the back camera of your smart device as this will scan the QR code more accurately.

4. Watch the video...



The video guide will now be displayed on your smart device.

Disclaimer: The garden building constructed in the video guides may be constructed differently to your building. Please ensure to read your instructions carefully to avoid error.

Before assembly please make sure you have a suitable base ready to erect your building

MADE IN GREAT BRITAIN

Overall Dimensions: Width = 2965mm
Depth = 3640mm
Height = 2156mm



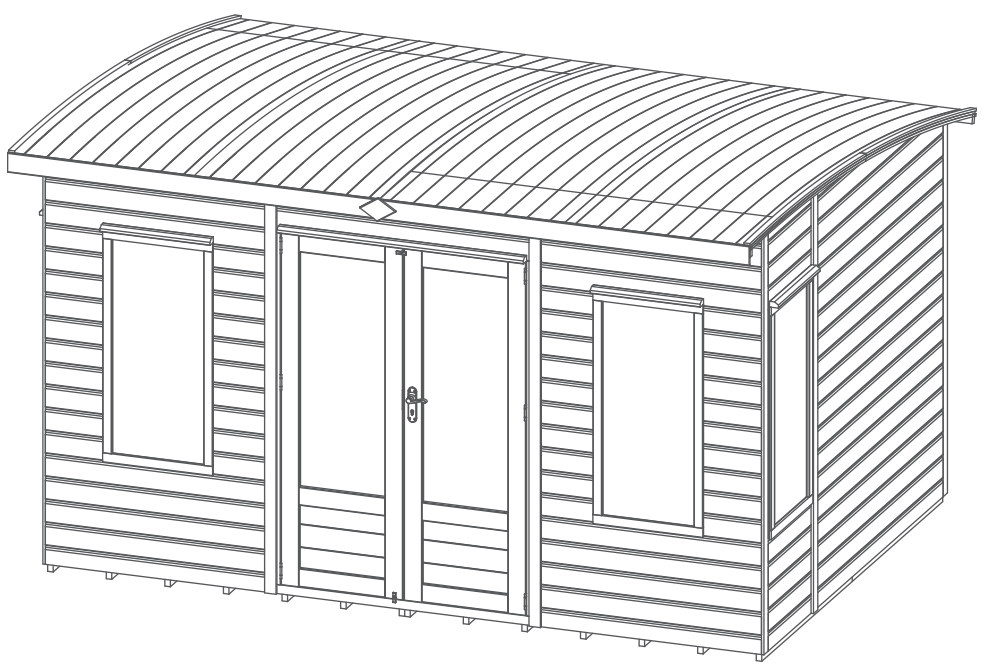





Base Dimensions: Width = 2350mm
Depth = 3506mm

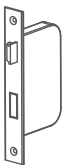

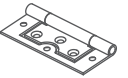
Building Content:

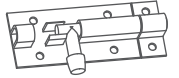

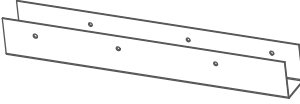

<p>1</p> <p>Door Panel QTY 1 <i>AI-03S22SHDD1298X2095-V1</i></p>	<p>2</p> <p>Front Window Panel QTY 2 <i>AI-03S21SH1FSFWC1109X2095-V1</i></p>	<p>3</p> <p>Side Window Panel QTY 2 <i>AI-03S21SH1FSFWC572X1782-V1</i></p>	<p>4</p> <p>Back Panel QTY 3 <i>AI-S21SHPP1172X1832-V1</i></p>	<p>5</p> <p>Side Panel QTY 2 <i>AI-S21SHPTF1700X1782-V1</i></p>
<p>6</p> <p>Left Gable QTY 1 <i>AI-S21SHCGTL2272X323-V1</i> Blue Label</p>	<p>8</p> <p>Floor QTY 4 <i>AI-S21MBF1753X1175-V1</i></p>	<p>9</p> <p>Roof QTY 4 <i>AI-S21MBCR910X2950-V1</i></p>	<p>10</p> <p>Master Door QTY 1 <i>AI-PRMHGMD600X1715-V1</i></p>	<p>11</p> <p>Secondary Door QTY 1 <i>AI-PRMHGSD600X1715-V1</i></p>

<p>12</p> <p>Roof Block - 28x28x140mm QTY 6 <i>FS2828-G-160mm (angled)</i></p>	<p>13</p> <p>Door Rain Guard - 28x44x1210mm QTY 1 <i>RG2844-1210mm</i></p>	<p>14</p> <p>Window Rain Guard - 28x44x540mm QTY 4 <i>RG2844-540mm</i></p>	<p>15</p> <p>Door Beading - 17x12x1711mm QTY 2 <i>S1217-1711mm</i></p>	<p>16</p> <p>Roof Trim - 30x12x1510mm QTY 8 <i>S1230-1510mm</i></p>	<p>17</p> <p>Fascia - 95x12x1820mm QTY 2 <i>SR1295-1820mm</i></p>	<p>18</p> <p>Front Cover Trim - 56x12x2088mm QTY 4 <i>S1256-2088mm</i></p>	<p>19</p> <p>Side Cover Trim - 56x12x2070mm QTY 2 <i>S1256-2070mm</i></p>	<p>20</p> <p>Rear Cover Trim - 56x12x1810mm QTY 4 <i>S1256-1810mm</i></p>	<p>21</p> <p>Ridge Bar - 90x27x1714mm QTY 6 <i>F2790-1714mm</i></p>	<p>22</p> <p>Door Bar - 60x16x1705mm QTY 1 <i>S1660-1705mm</i></p>	<p>23</p> <p>Floor Block - 44x27x400mm QTY 12 <i>F2744-400mm</i></p>	<p>24</p> <p>Roof End - 83x12x2950mm QTY 4 <i>MB12RT83-2950mm</i></p>
---	---	---	---	--	--	---	--	--	--	---	---	--

- 25** 
Mortice Lock QTY 1
PI-07-0017
- 26** 
Key Plate QTY 1
- 27** 
Hinge QTY 6
PI-07-0023
- 28** 
Turn Button QTY 2
PI-07-0034
- 29** 
Tower Bolt QTY 2
PI-07-0114
- 30** 
Finial QTY 1
Shed Diamond Finial
- 31** 
Door Handle QTY 1
PI-07-0001
- 32** 
U Channel QTY 6
PI-07-0013
- 33** 
Felt

Nail Bag

There may be extra screws present in the nail bag

-  **80mm Screw x 12**
-  **30mm Screw x 382**
-  **50mm Screw x 122**
-  **40mm Screw x 46**
-  **Felt Tacks x 190**

Pre Assembly

Before assembling remove the transportation blocks from the bottom of each panel.

Take care removing the blocks as to not damage the panels. Tap with a flat headed screwdriver and hammer.

Dispose of the blocks once removed.

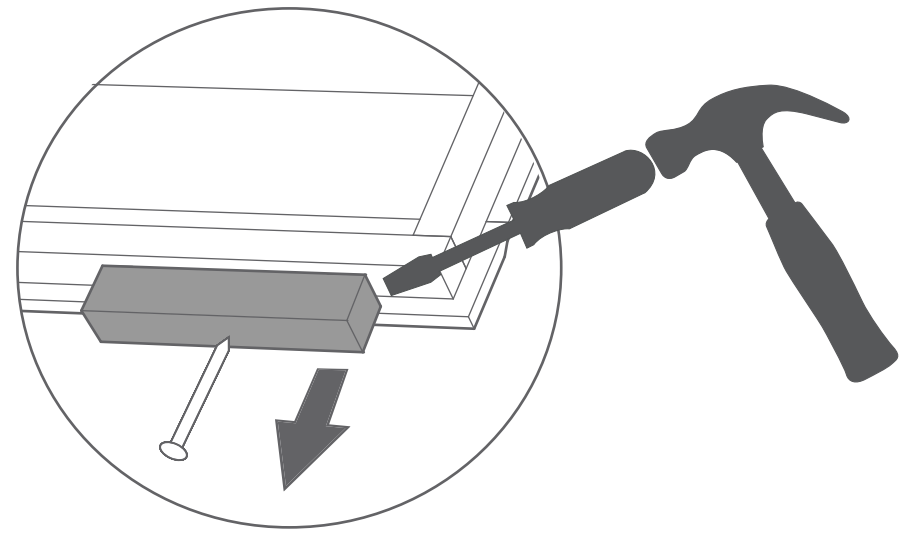

IMPORTANT: Pre-drill before fixing screws.

Step 2

IMPORTANT: Pre-drill before fixing screws.

Step 1

- Parts Needed - No. 1 QTY 1 - No. 26 QTY 1**
 - No. 10 QTY 1 - No. 27 QTY 6
 - No. 11 QTY 1 - No. 31 QTY 1
 - No. 25 QTY 11

- Parts Needed - No. 15 QTY 2**
 - No. 22 QTY 1
 - No. 29 QTY 2

a Fix the hinges (**No. 27**) to the door frames (**No. 10 & 11**) using 40mm screws. Ensure the hinges are attached using the outer plate of the hinge.

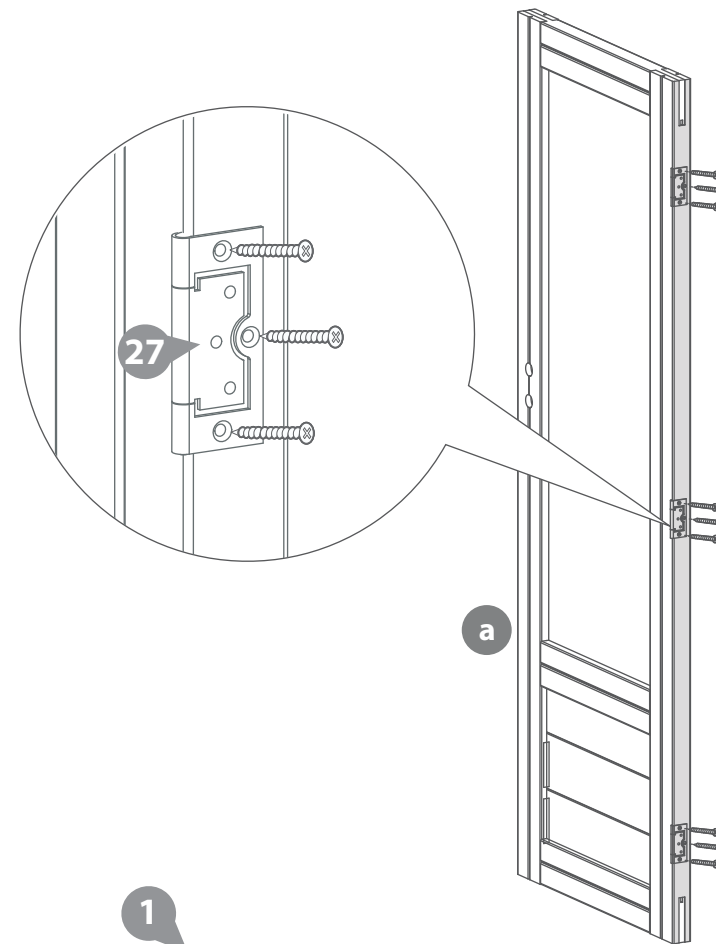

Attach the doors to the Door Panel (**No. 1**) with 40mm screws making sure to use the inner plate of the hinge.

b Fit the Mortice Lock (**No. 25**) into the recess and fix in place with the screws provided. Fit the Key Plate (**No. 26**) to the opposite door using the screws provided.

c Fix the Door Handles (**No. 31**) and the metal bar (spindle) using 8x30mm screws. Ensure the mortice lock closes correctly. If not, remove lock and turn the catch around using the small grub screw.

8x30mm screws
 36x40mm screws

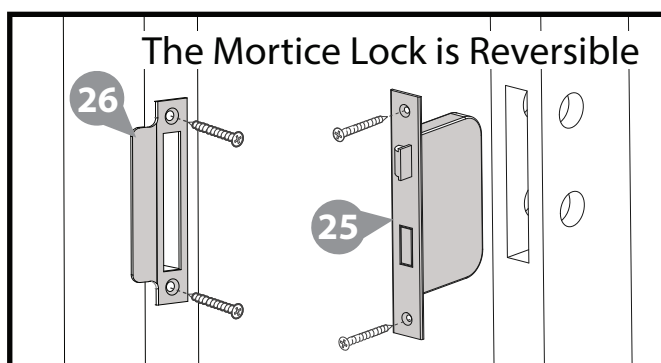
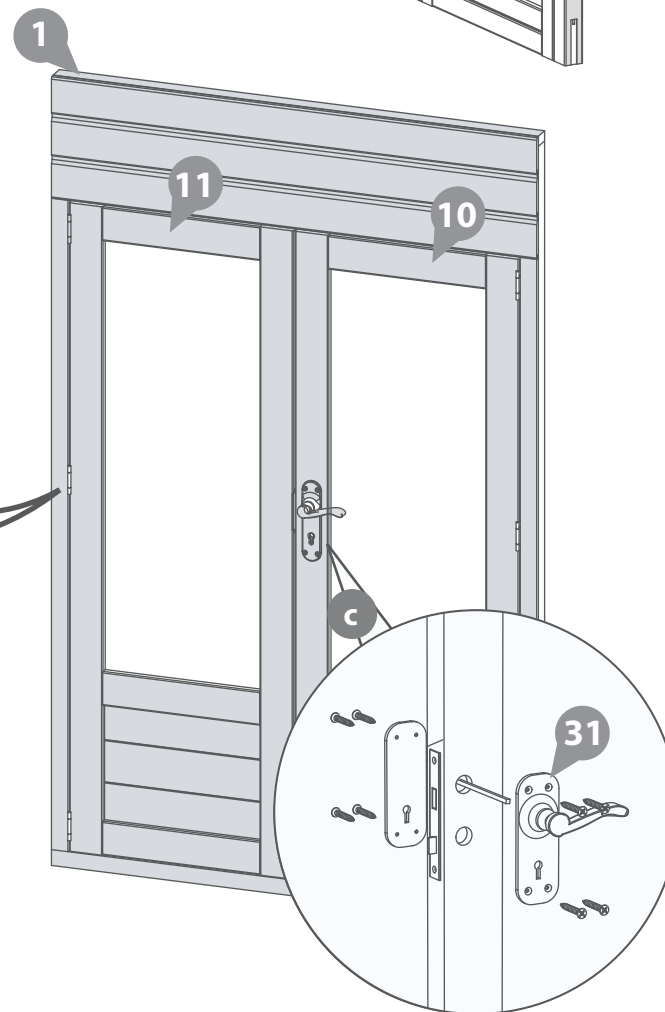
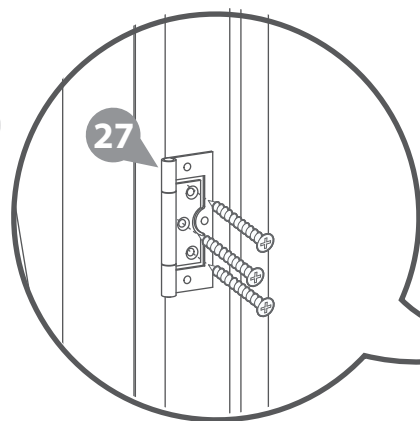

d Fix the Door Bar (**No. 22**) to the inside of the Secondary Door using 6x30mm screws as shown in the illustration.

Fit the Door Beading (**No. 15**) to the inside of the door frame using 8x30mm screws, ensuring that they sit flush with the frame and the door.

e Place the Tower Bolts (**No. 29**) roughly into position at the top/bottom of the Door beading. With a pencil mark around the bolt.

After marking the bolt onto the strips, drill a hole for the barrel bolt to locate into.

Following the hole being drilled, place the tower bolts into position and secure using 4x30mm screws per bolt.

Ensure doors open and close freely.

22x30mm screws

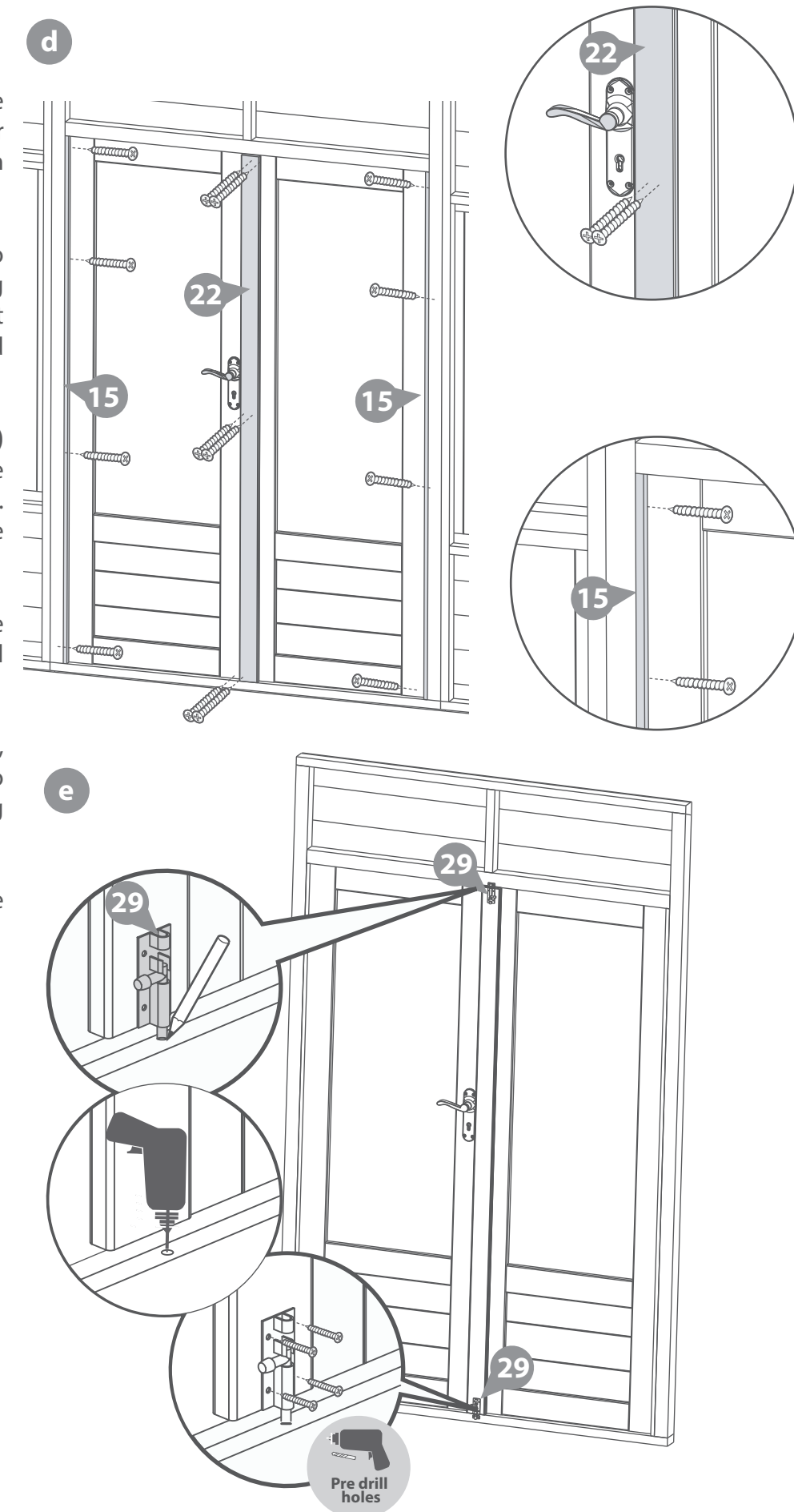

Pre drill holes

Step 3

Parts Needed - No. 8 QTY 2
- No. 23 QTY 12

Secure the floor (**No. 8**) to the Floor Blocks (**No. 23**) using 12x30mm screws per floor.

Repeat this for one other floor panel.

24x30mm Screws

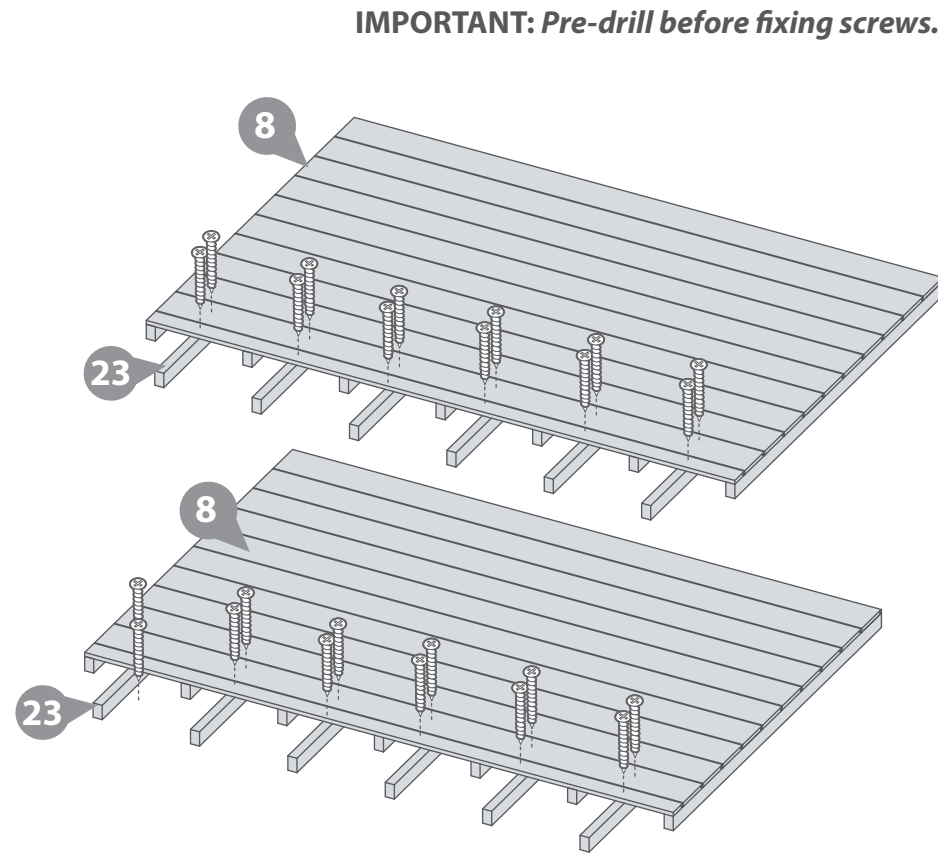

Step 5

Place the assembled floor panels (**No. 8**) on to a firm and level base. Ensure the base has suitable drainage, free from areas where standing water can collect.

Secure the floors together using 8x50mm screws through the floor bearers in an alternating pattern.

8x50mm Screws

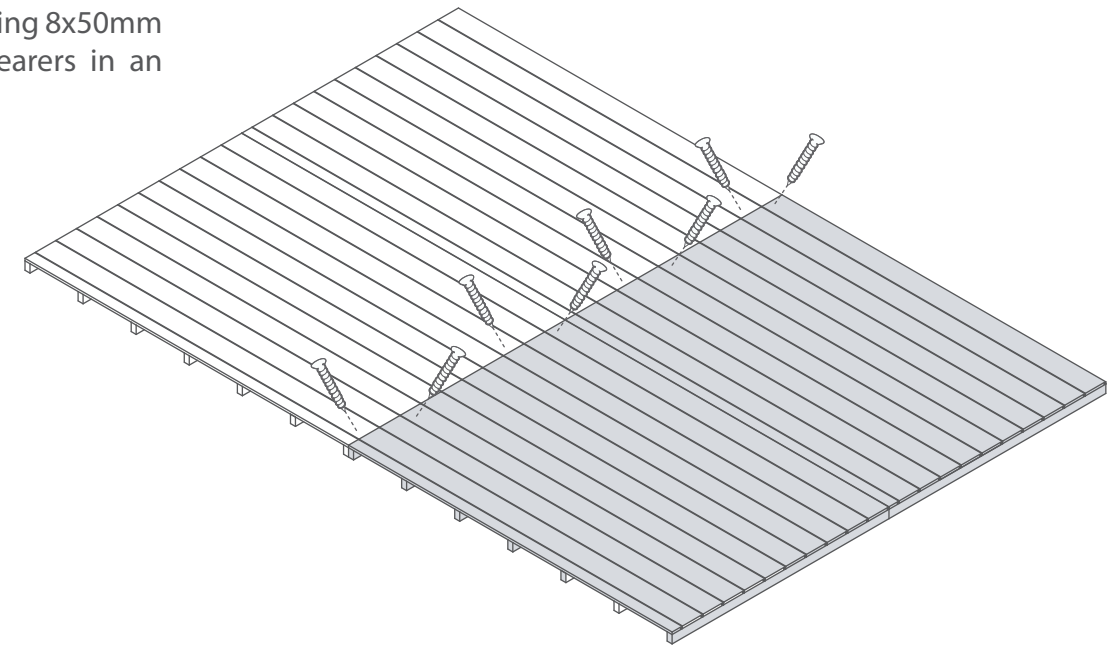

Step 4

Parts Needed - No. 8 QTY 2

Secure the floor (**No. 8**) to the assembly from Step 3, using 12x30mm screws per floor.

Repeat this to create two assembled floors.

24x30mm Screws

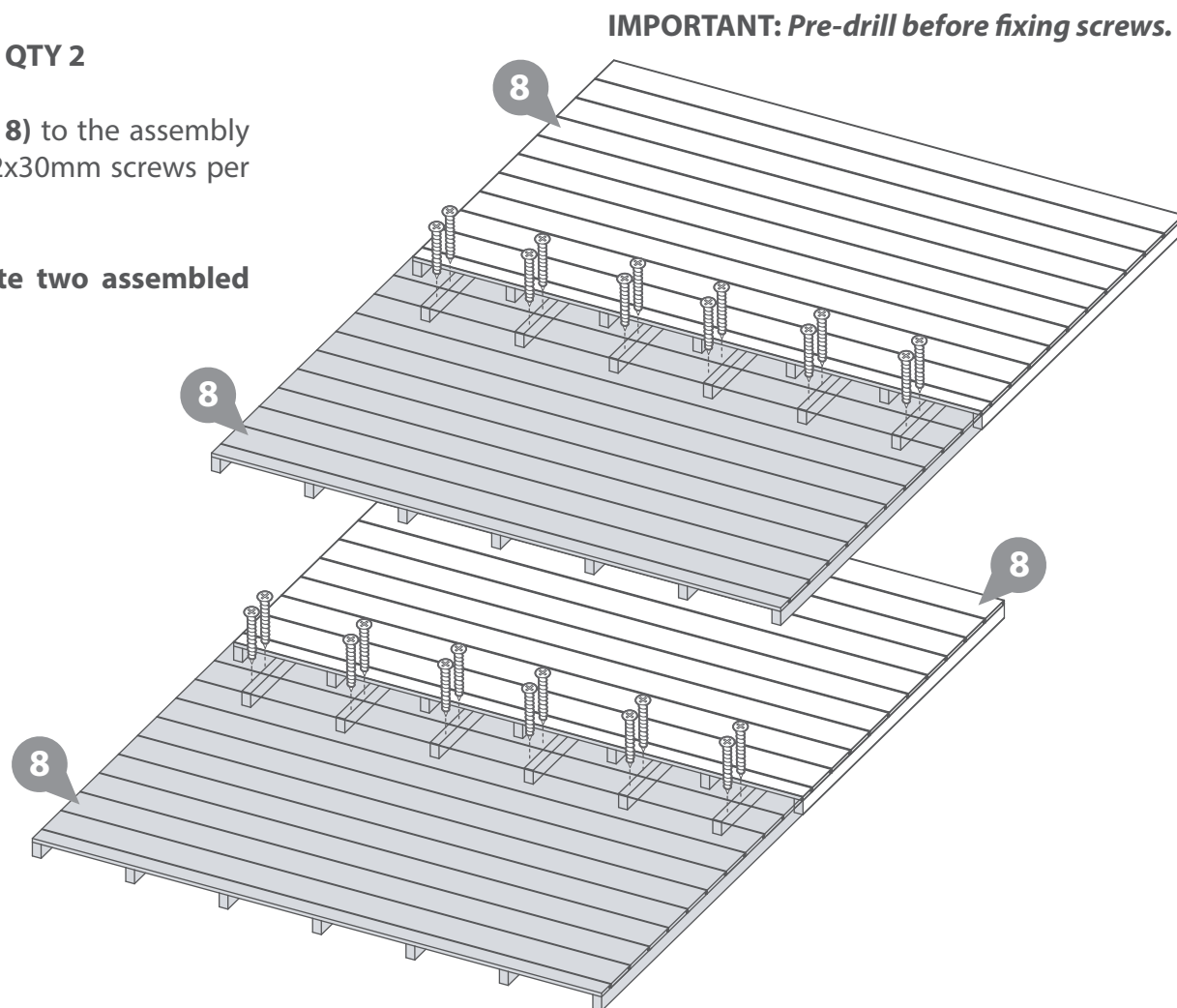

Step 6

Parts Needed - No. 4 QTY 2
- No. 5 QTY 1

Fix two of the Back panels (**No. 4**) side by side using 3x50mm screws, fix the corners of the back panel (**No. 4**) and the Side Panel (**No. 5**).

Do **NOT** secure the building to the floor until the roof is fitted.

Position the panels so there is equal spacing between the floor and the cladding on all sides.

6x50mm Screws

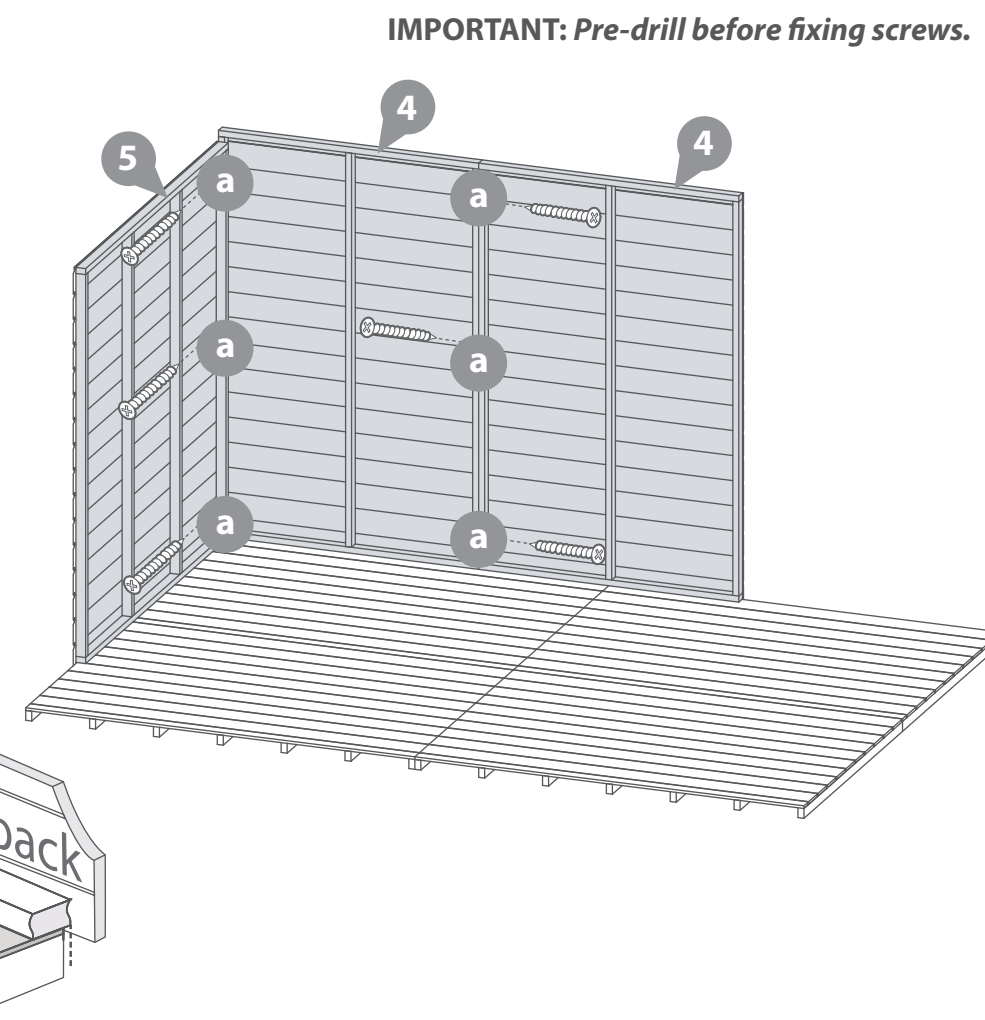
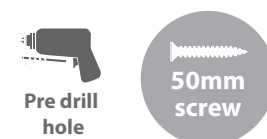

Step 7
Parts Needed - No. 4 QTY 1
- No. 5 QTY 1

Fix the last back panel (**No. 4**) next to the already standing back panel using 3x50mm screws. Then fix the corners of the side panel (**No. 5**) to the last back panel using 3x50mm screws.

Do **NOT** secure the building to the floor until the roof is fitted.

Position the panels so there is equal spacing between the floor and the cladding on all sides.

6x50mm Screws

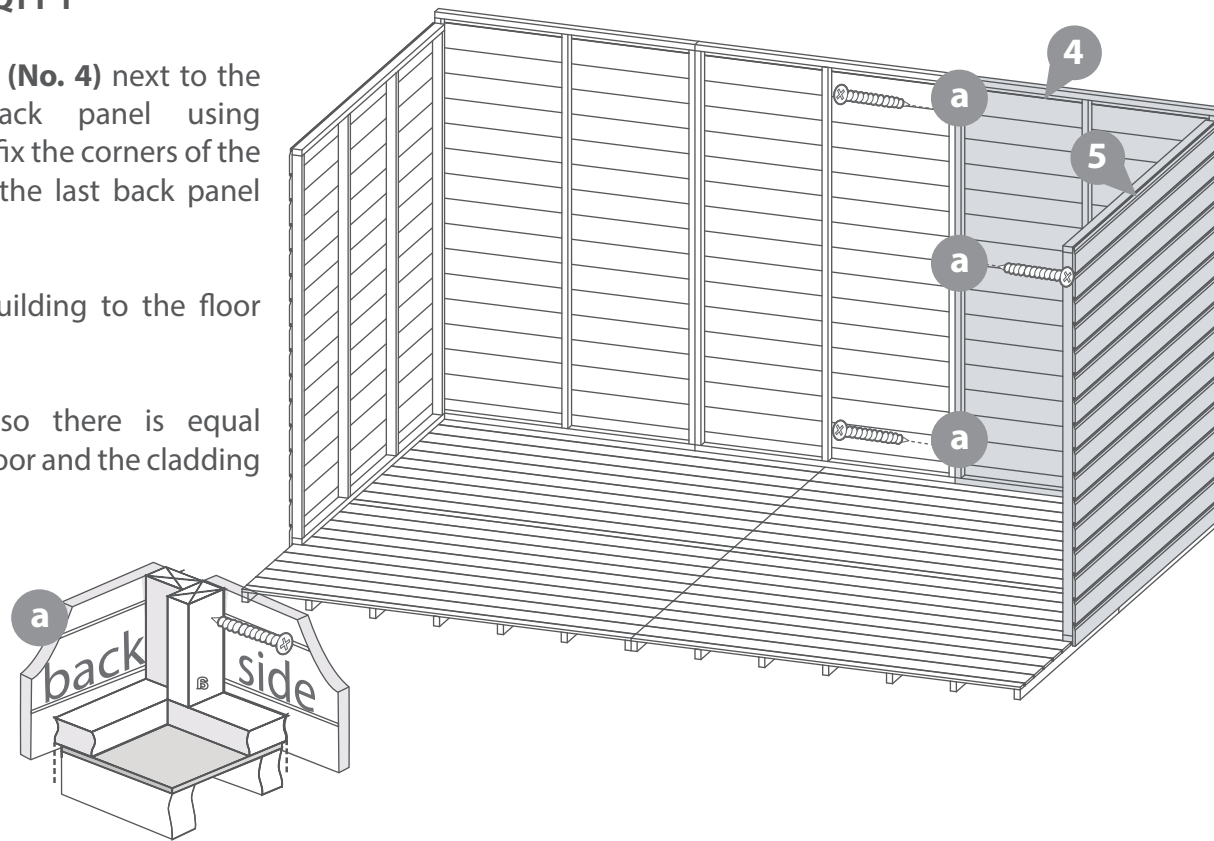

Step 8
Parts Needed - No. 3 QTY 2

Fix the Side Window Panel (**No. 3**) and already standing Side Panel (**No. 5**) together by screwing through the framing using 8x50mm screws.

Ensure to stagger screws to avoid colliding.

Repeat this with the second Window (**No. 3**) and Side panel (**No. 5**) but the opposite way round, as shown in the diagram.

Do **NOT** secure the building to the floor until the roof is fitted.

Position the panels so there is equal spacing between the floor and the cladding on all sides.

8x50mm Screws

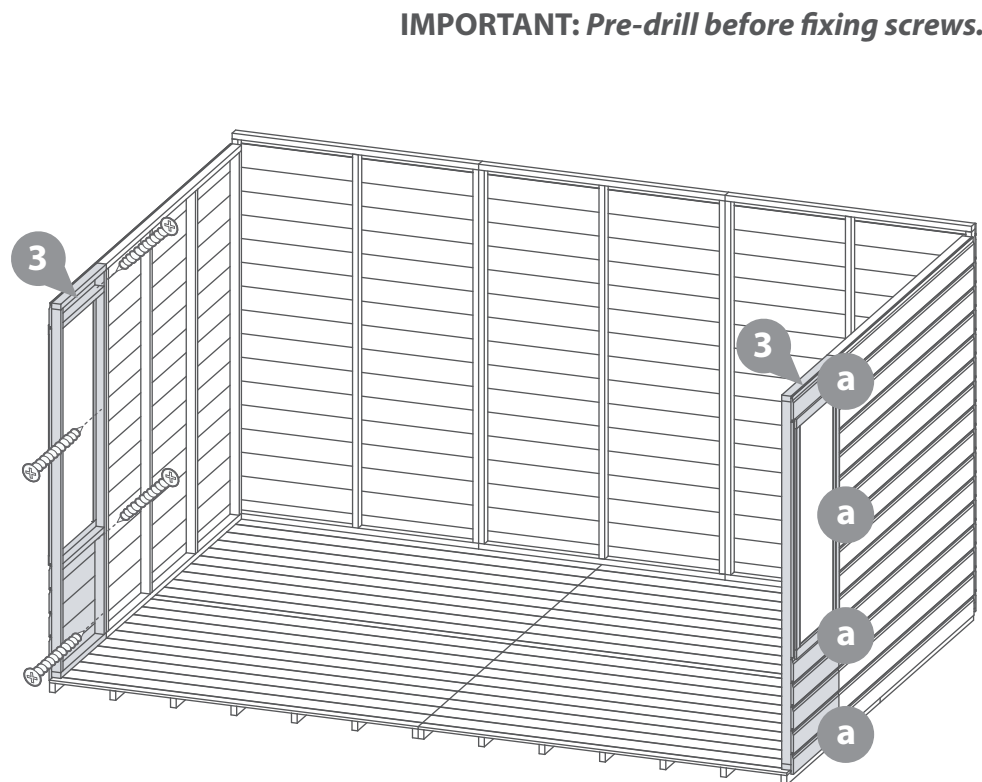

Step 9
Parts Needed - No. 6 QTY 1
- No. 7 QTY 1

Place the Left Gable (**No. 6**) and Right Gable (**No. 7**) on top of the side panels, ensuring the boards interlock.

Secure in place using 4x50mm screws per gable top, screwing in an alternating pattern.

8x50mm Screws



IMPORTANT: Pre-drill before fixing screws.

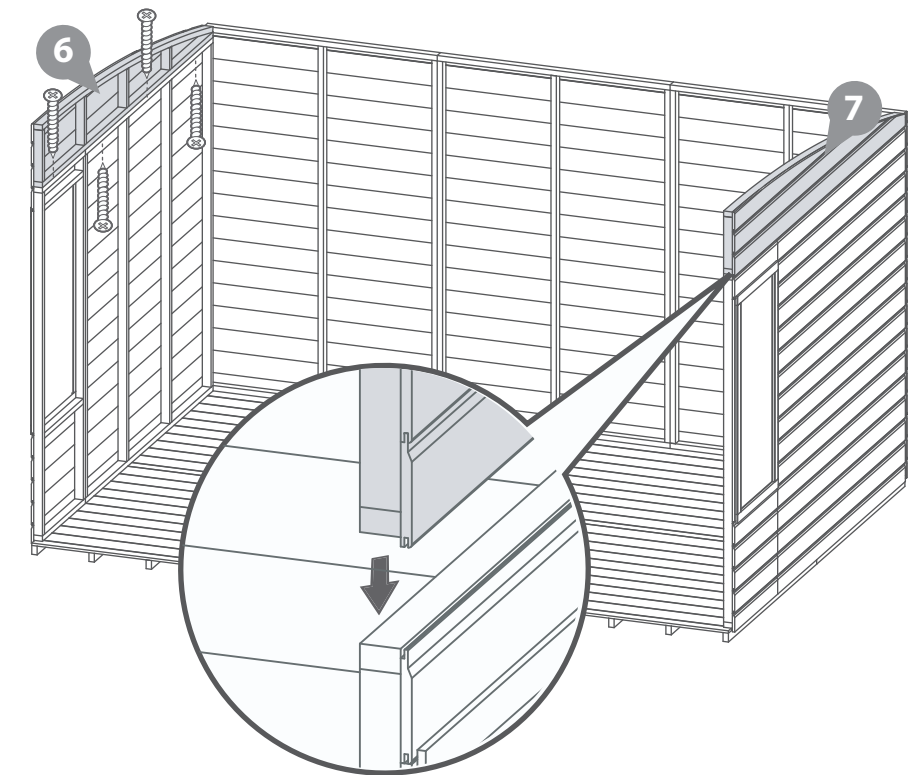

Step 10
Parts Needed - No.2 QTY 2

Fix the Front Window Panels (**No. 2**) together with the Side Window Panels (**No. 3**) corners with 50mm screws as shown in the illustration.

Do **NOT** secure the building to the floor until the roof is fitted.

Position the panels so there is equal spacing between the floor and the cladding on all sides.

6x50mm Screws

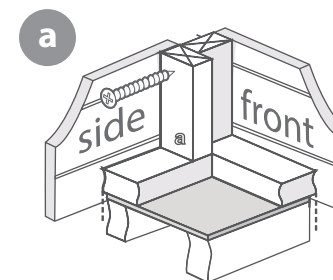

IMPORTANT: Pre-drill before fixing screws.

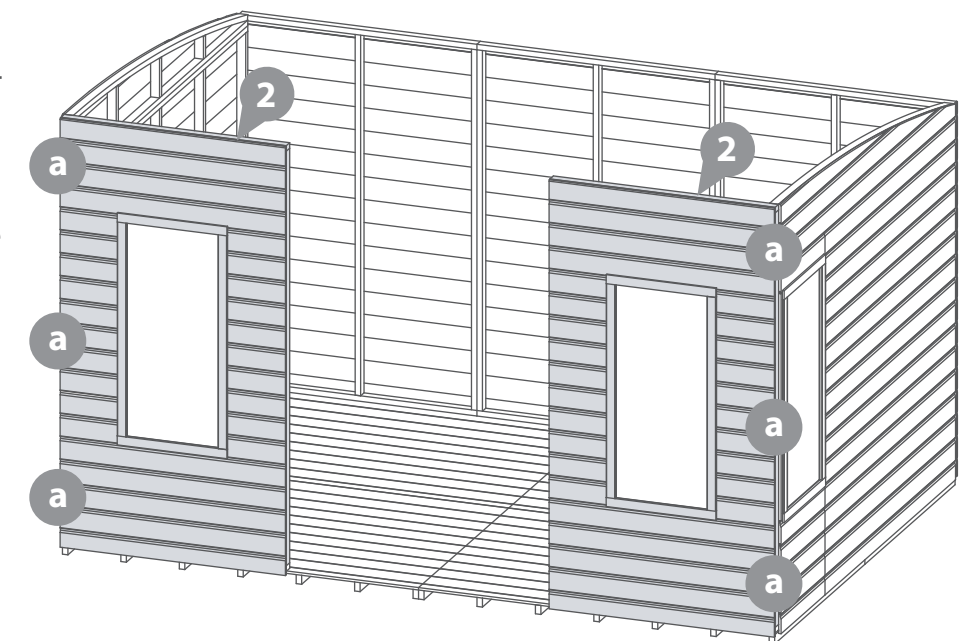

Step 11
Parts Needed - No. 1 QTY 1

Place the assembled door panel (**No. 1**) onto the floor in-between the already standing Front Window Panels (**No. 2**).

Fix the panels together at the corners using 4x50mm screws per side.

Do **NOT** secure the building to the floor until the roof is fitted.

Position the panels so there is equal spacing between the floor and cladding on all sides.

8x50mm Screws



50mm screw

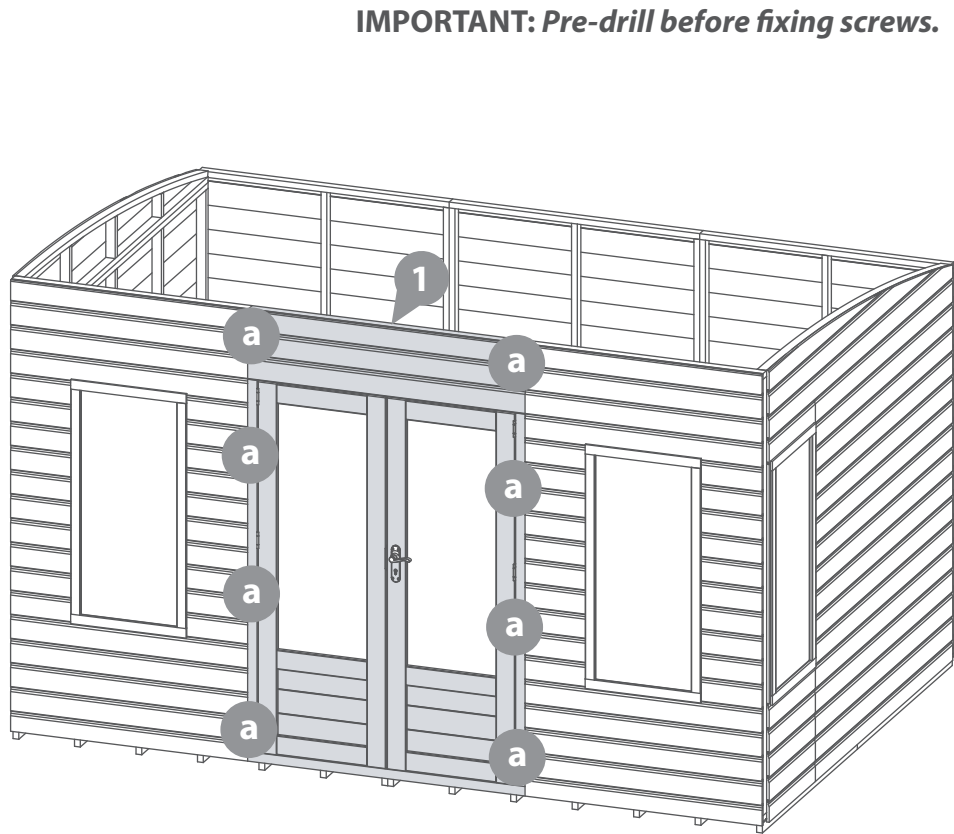

IMPORTANT: Pre-drill before fixing screws.

Step 12
Parts Needed - No. 21 QTY 6
- No. 32 QTY 3

Place two Ridge Bars (**No. 21**) inside a U-Channel (**No. 32**) butt up to each other as shown in the illustration.

Secure in place using 10x30mm screws per U-Channel.

Repeat the process to create another two assembled Ridge Bars.

30x30mm Screws



30mm screw

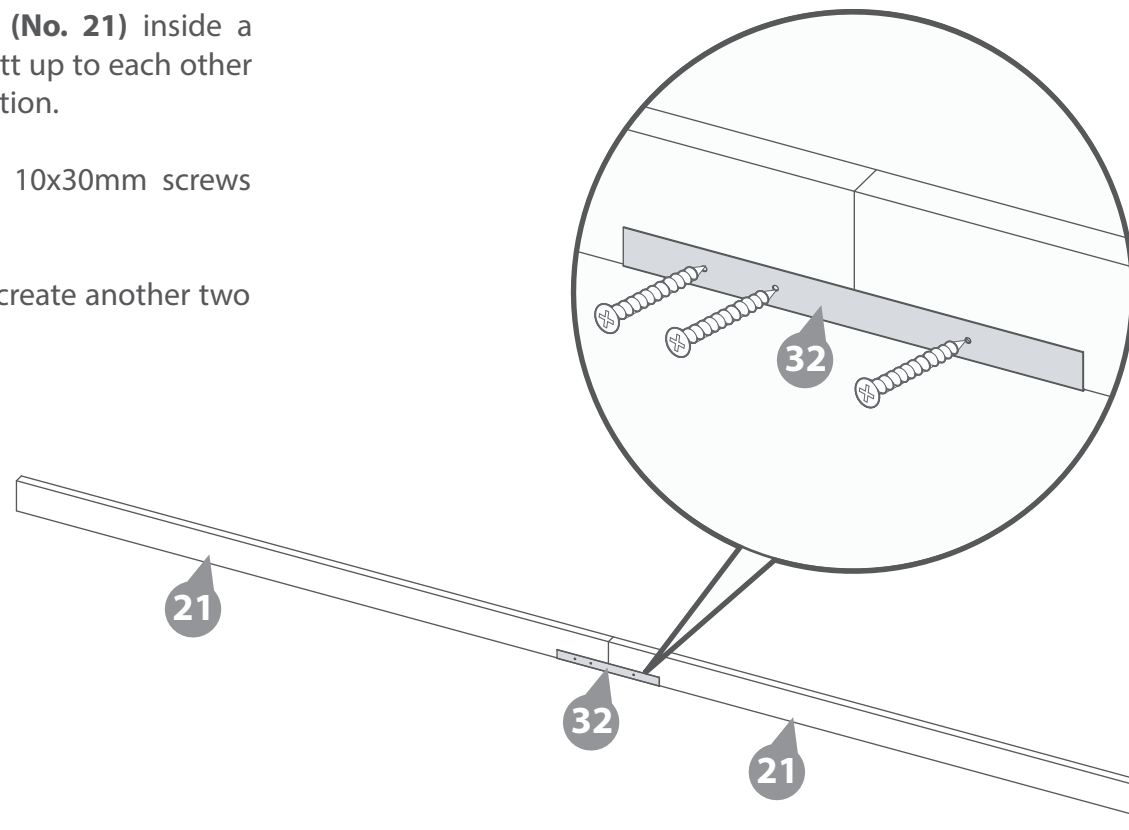

Step 13
Parts Needed - No. 12 QTY 6

a Place the first assembled Ridge Bar (**No. 21**) inside the building, centralise it with the vertical gable framing. Align the back edge of the ridge bar with the top of the gable. Once in place mark the position on both sides with a pencil.

Place the top edge of the roof support block (**No. 12**) flush to the pencil mark and secure in place using 2x50mm screws per block.

*Repeat this process on both sides for the remaining assembled Ridge Bars.

b Place the assembled Ridge Bar(s) on top of the attached blocks and secure through the outside of both gables using 2x80mm screws per side.

12x50mm Screws
12x80mm Screws



50mm screw

80mm screw

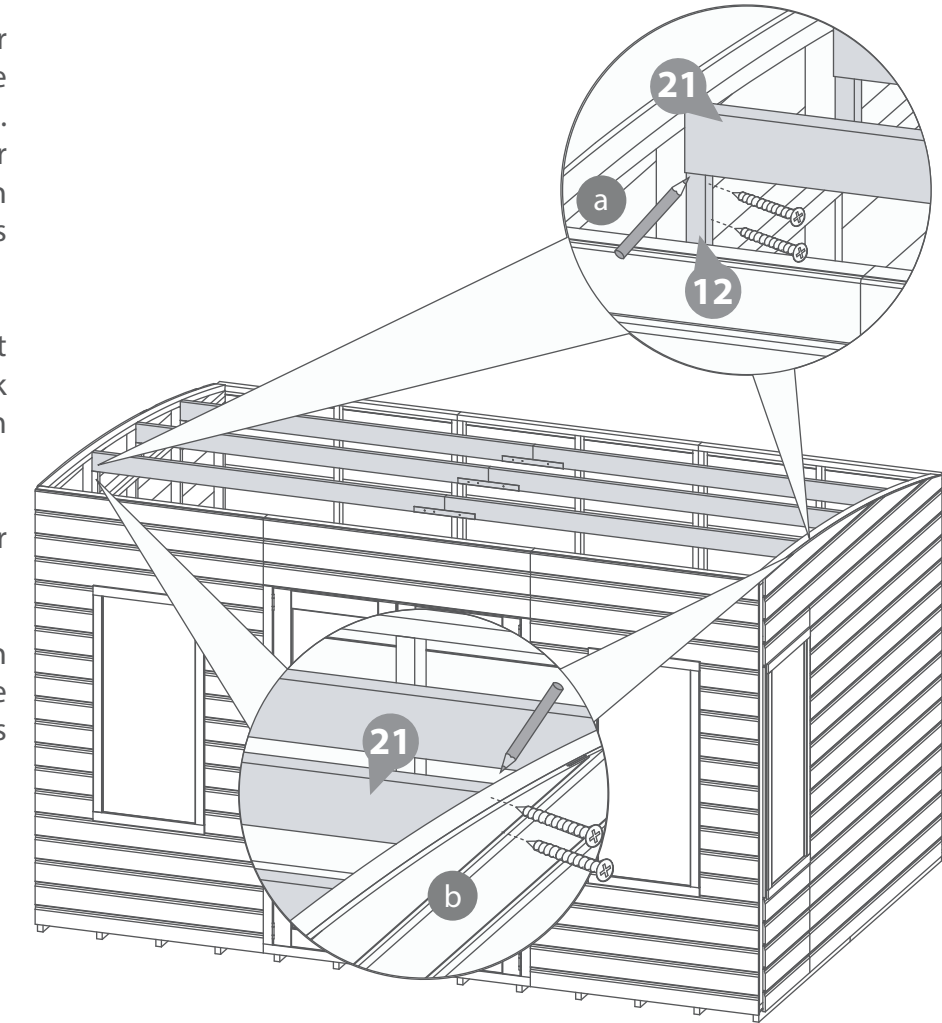

IMPORTANT: Pre-drill before fixing screws.

***Hint: When fitting the Ridge Bar pencil mark the centre of the Ridge Bar and follow down onto the gable at a right angle, this will give you a guide to fix the support bars in place.**

Step 14

Parts Needed - No. 9 QTY 4
- No. 24 QTY 4

Place the four roofs (**No. 9**) together. Please note that two of the Roof Panels **MUST** go the opposite way to the other two Roof Panels.

Then slot the four Roof End (**No. 24**) pieces on to the Roof Panels where shown in the diagram.

Fix the Roof Ends (**No. 24**) to the top and bottom Framing within the Roof Panels using 2x30mm per end.

16x30mm Screws

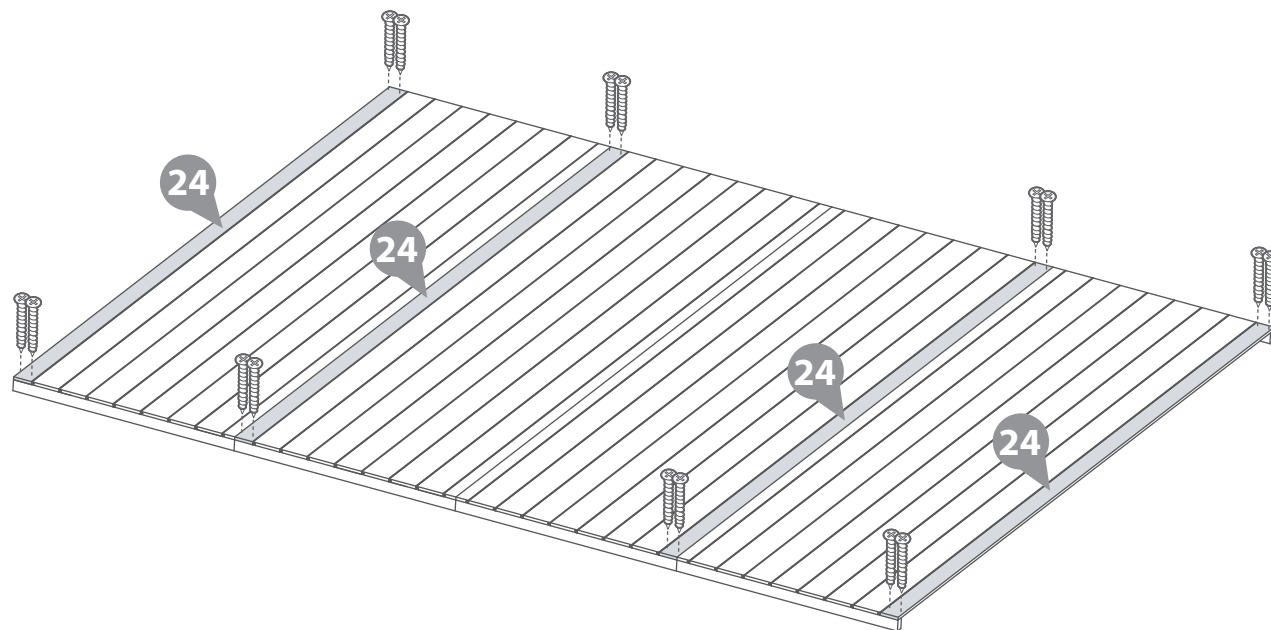
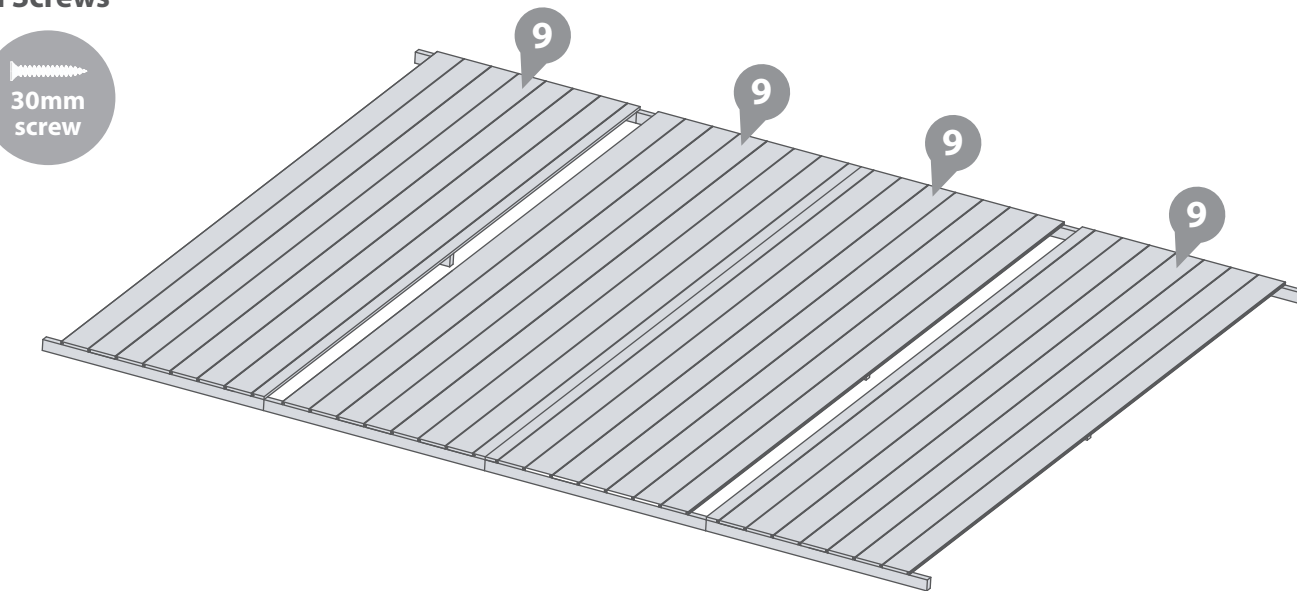

IMPORTANT: Pre-drill before fixing screws.

Step 15

Parts Needed - No. 9 QTY 4
- No. 32 QTY 3

a Place the Roof Panels (**No. 9**) on top of the Building. Join together the centre framing on the underside of the roofs to the three U Channels (**No. 32**) using 30mm screws as shown in the diagram. Please note that there will be a space between the framing within two of the U Channels.

b Place the centre framing within the Roof Panels (**No. 9**) in front of the assembled middle Ridge Bar (**No. 21**) and secure together with 12x50mm screws as shown in the diagram. Ensure the screws line up with the roof support bars.

22x30mm Screws
12x50mm Screws

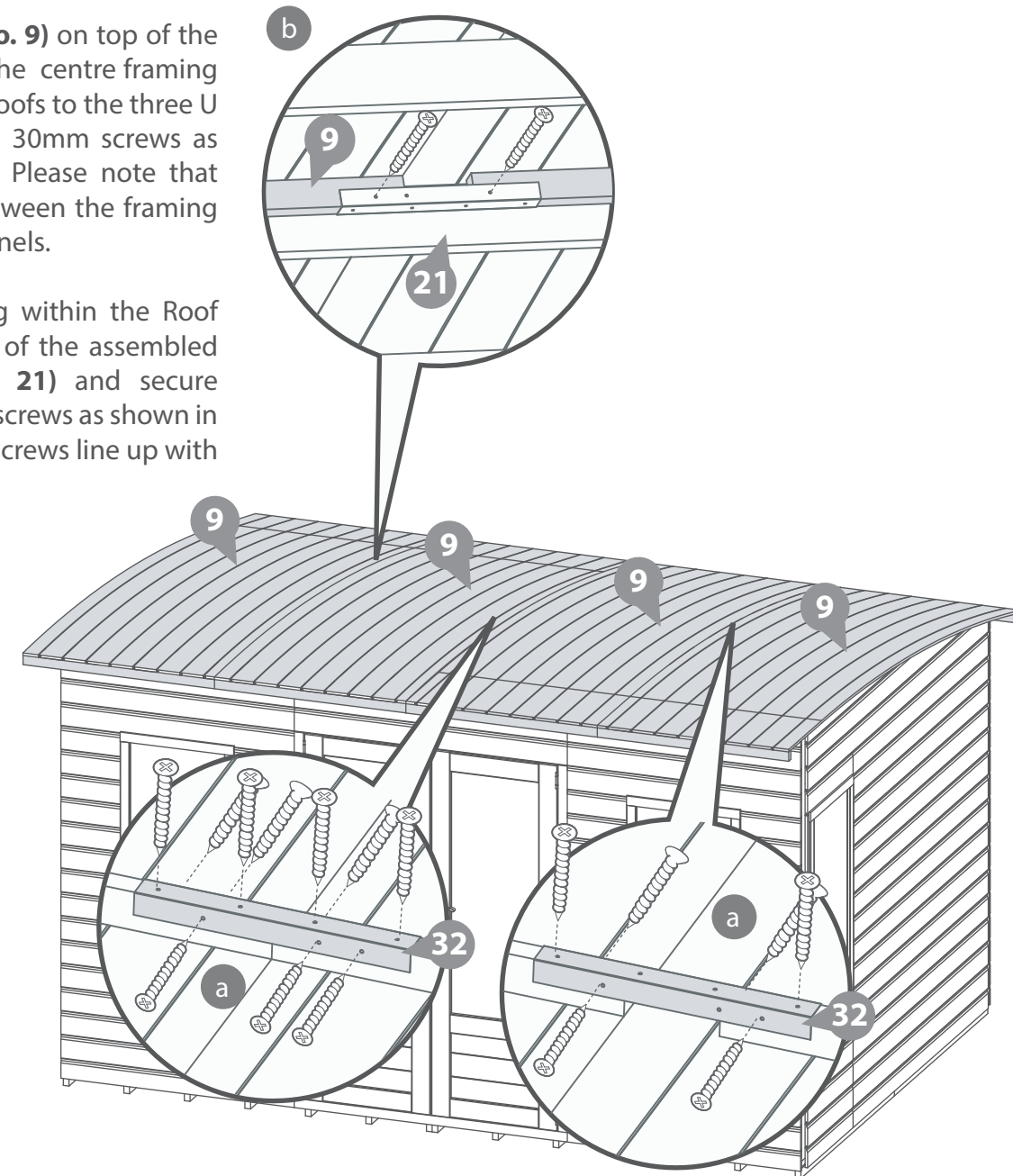

IMPORTANT: Pre-drill before fixing screws.

Step 16

Fix the Roof Panels to the Framing within the Panels and the Ridge Bars where they meet (internally) using 5x30mm screws per board.

HINT - Follow the nailing line of the framing on the roof panel so that you are more likely to fix into the ridge bar below. Also use a straight piece of timber as a guide to help keep the screw positions in a straight line.

180x30mm Screws

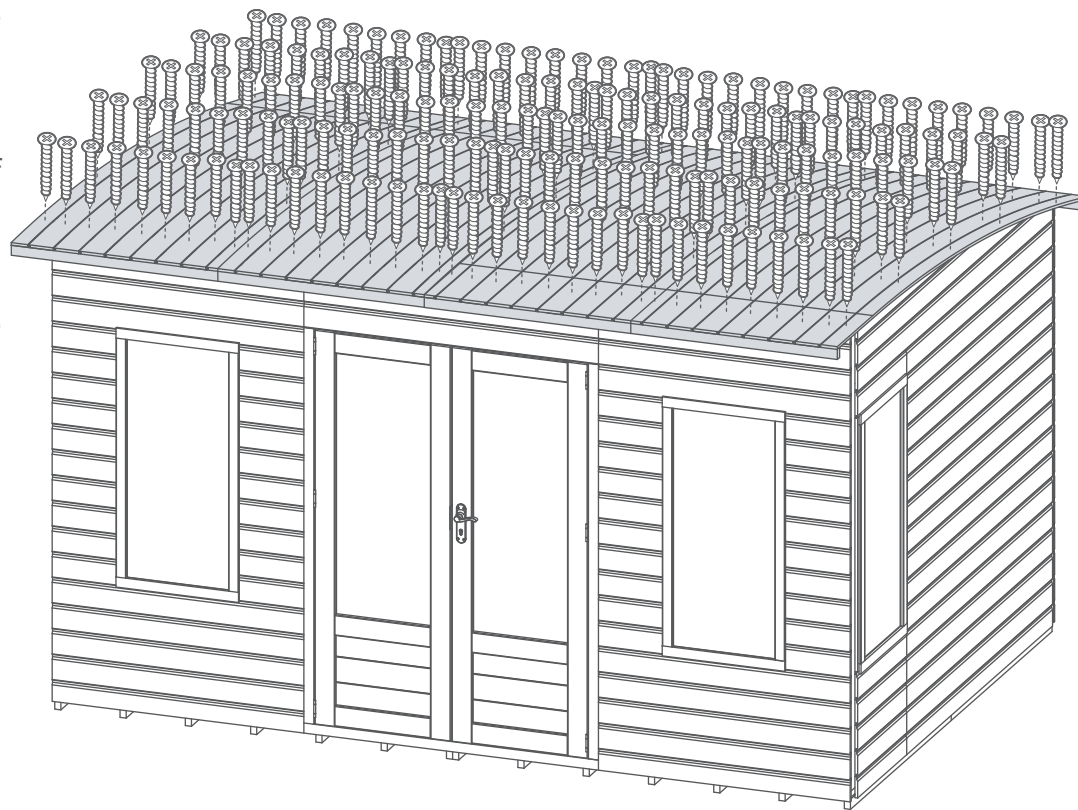
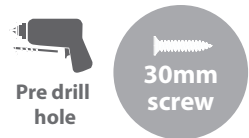

IMPORTANT: Pre-drill before fixing screws.

Step 18

Parts Needed - No. 33 QTY 1

Cut the felt (**No. 33**) into 4x sheets measuring: **3740mm (L) X 1000mm (W)** and lay onto the roof in the order shown in the illustration, leaving approximately 50mm of overhanging felt around the building.

Secure the felt to the building with 190x felt tacks at 100mm intervals

190 x Felt Tacks

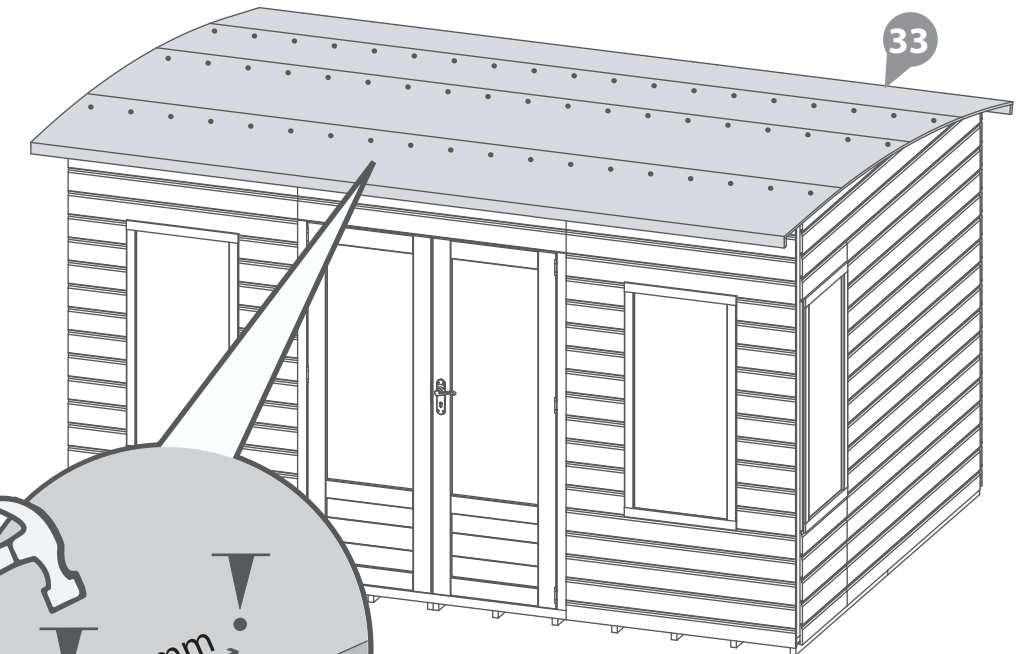

Step 17

Secure the building to the floor using 32x50mm screws.

***Ensure to align the screws with the floor bearers.**

32x50mm Screws



IMPORTANT: Pre-drill before fixing screws.

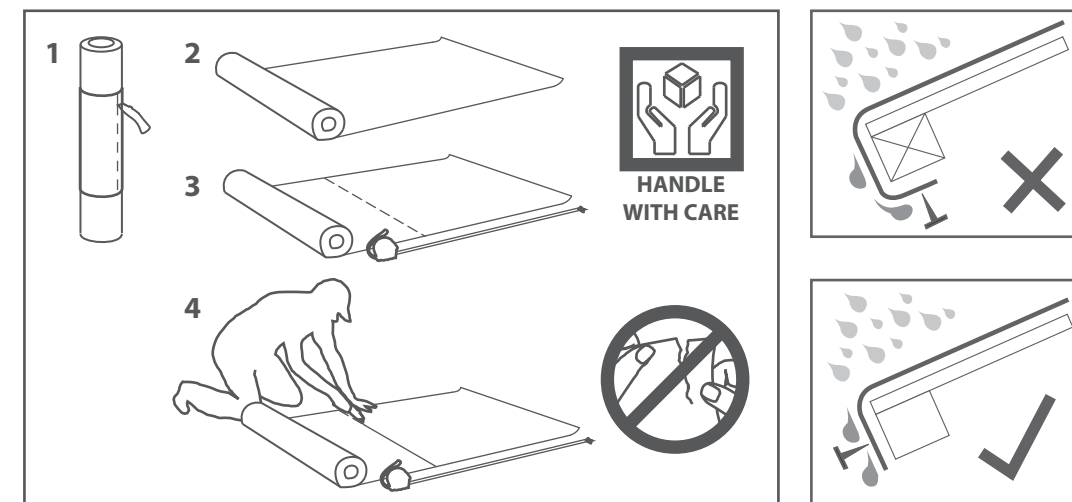
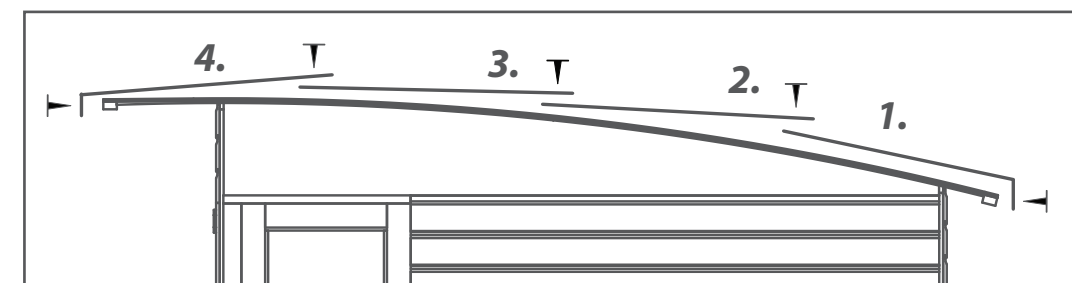
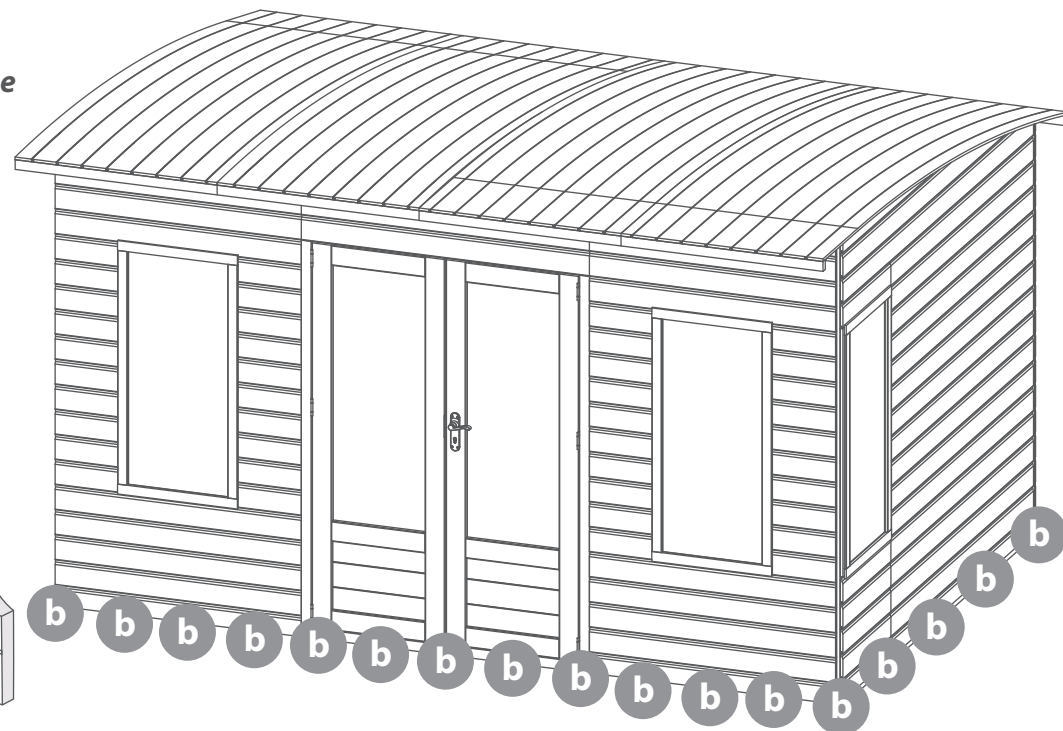

Step 19
Parts Needed - No. 16 QTY 8

Sandwich the felt either side between the roof and the roof trims (No. 16), fixing each strip to the roof with 3x30mm screws. The roof trims will need to be cut to fit.

24x30mm Screw

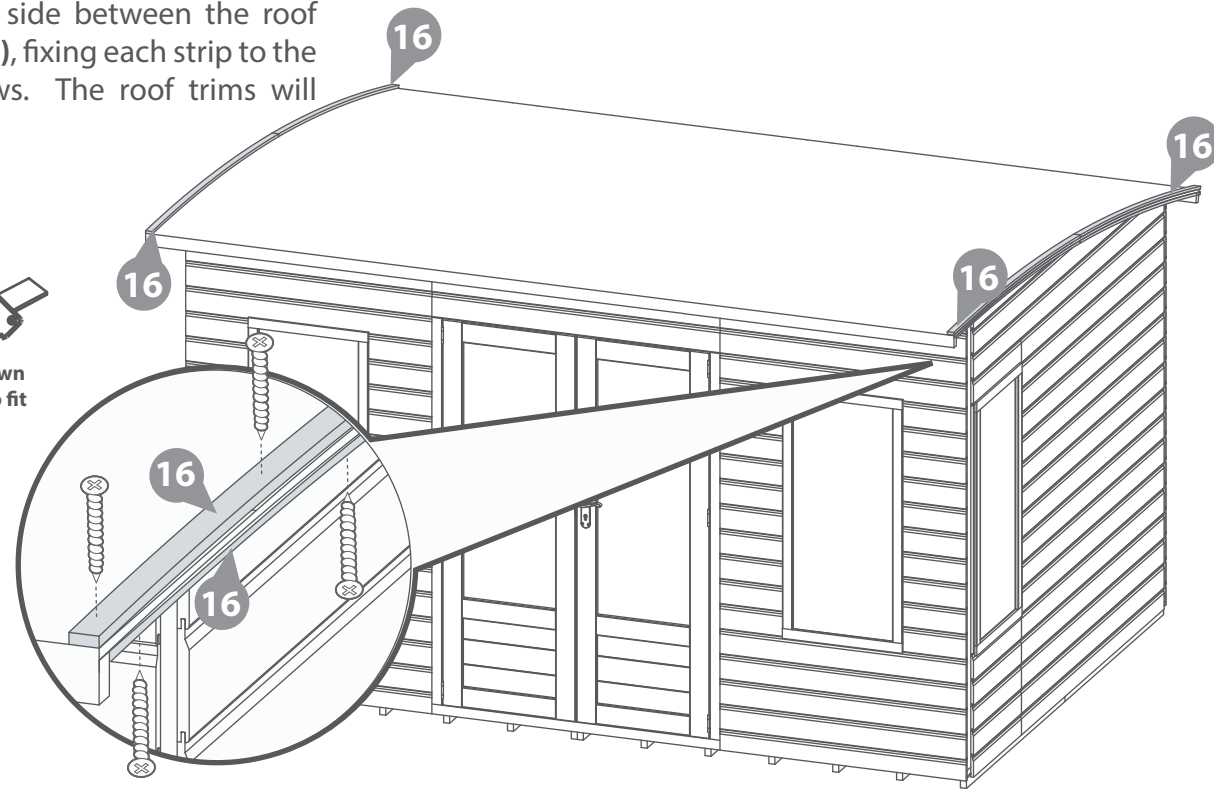
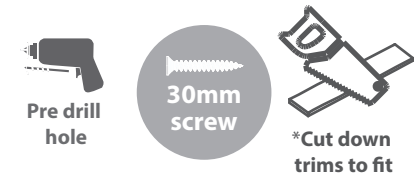

IMPORTANT: Pre-drill before fixing screws.

Step 21
Parts Needed - No. 18 QTY 4
- No. 19 QTY 2
- No. 20 QTY 4

Attach the front (No. 18), side (No. 19) and rear (No. 20) cover trims to the building, fixing each trim using 3x30mm screws.

Ensure a trim is fitted to each corner of the building and over the panel joins.

30x30mm Screws

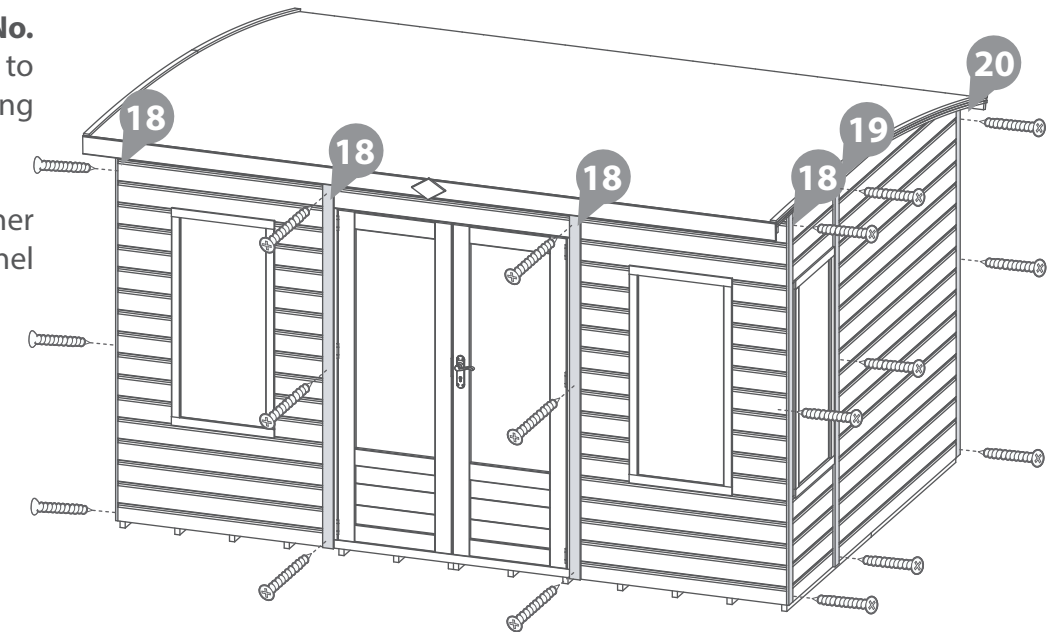
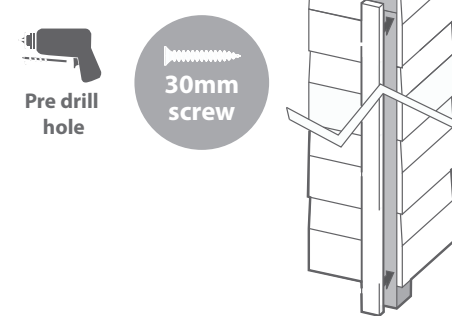

IMPORTANT: Pre-drill before fixing screws.

Step 20
Parts Needed - No. 17 QTY 2
- No. 30 QTY 1

Fix the fascia's (No. 17) to the front of the building using 4x40mm screws.

Attach the finial (No. 30) over the join in the fascia's with 2x40mm screws.

10x40mm Screws

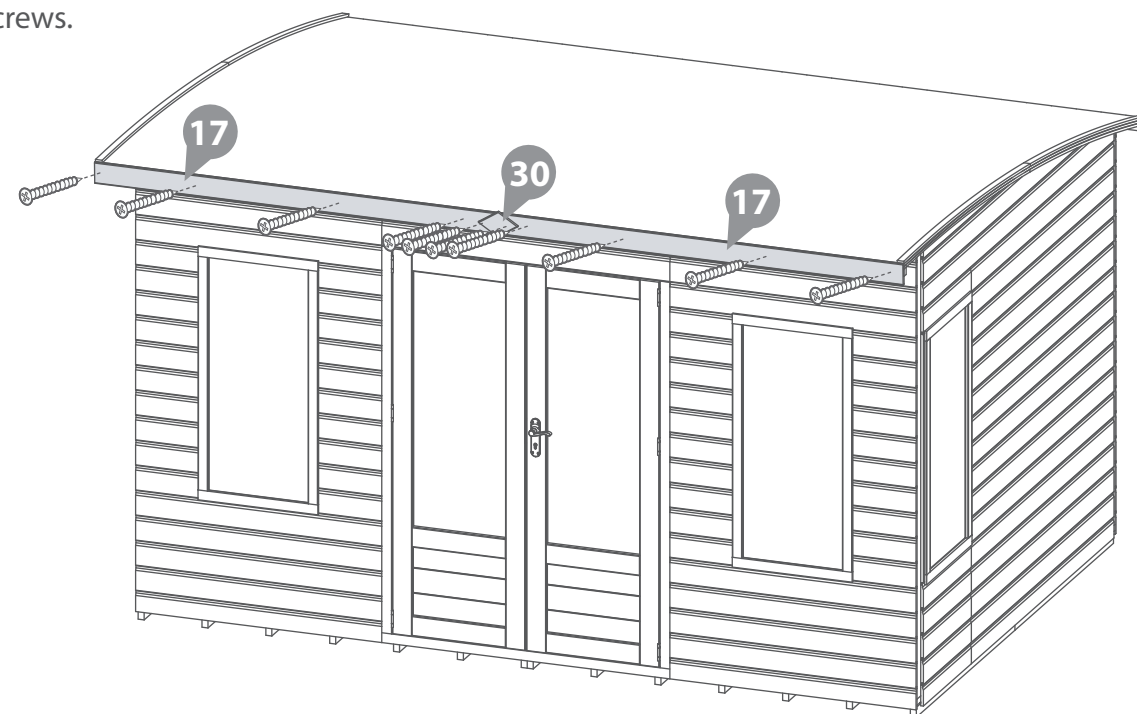
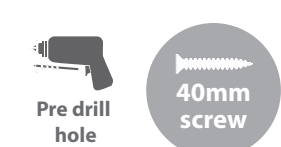

IMPORTANT: Pre-drill before fixing screws.

Step 22
Parts Needed - No. 13 QTY 1
- No. 14 QTY 4

Fix the Door Rain Guard (No. 13) above the door using 4x50mm screws.

Attach the Window Rain Guards (No. 14) above each window using 3x50mm screws per Rain Guard.

***Seal each rain guard with silicone sealant before fixing to the building.**

16x50mm Screws

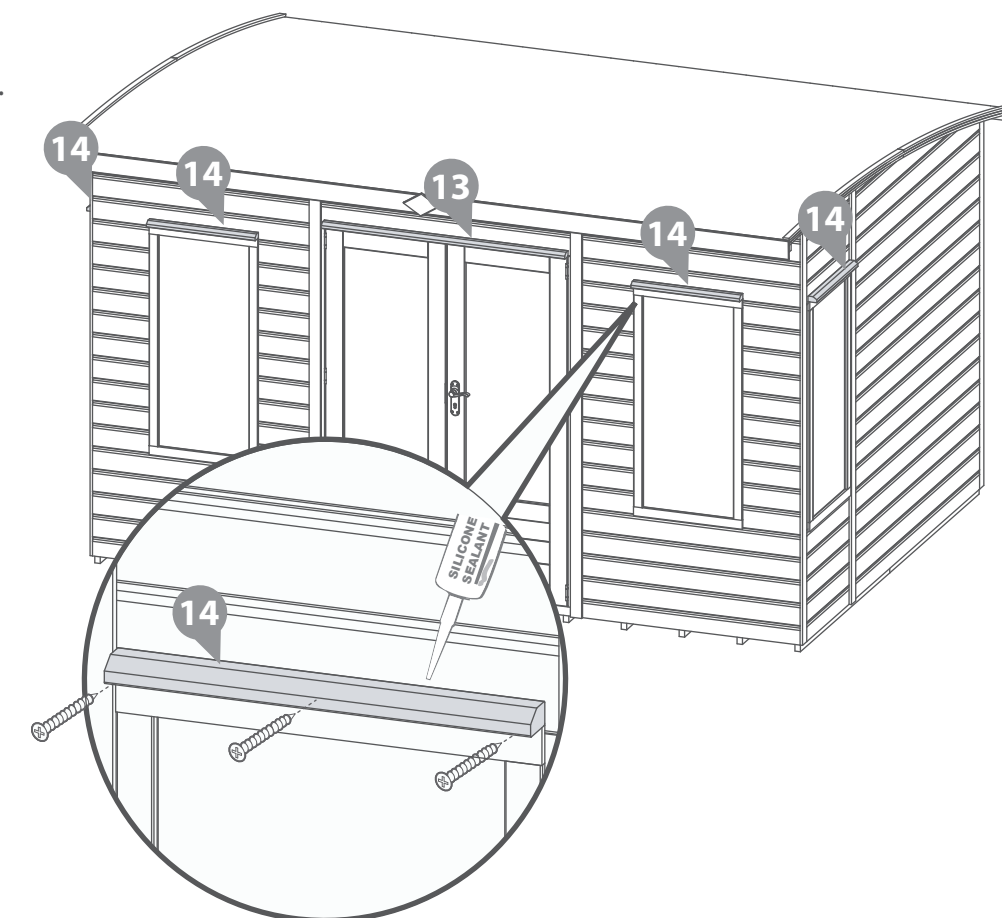
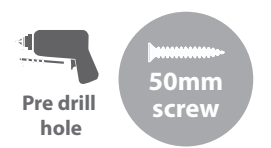

Step 23
Parts Needed - No. 28 QTY 2

IMPORTANT: Pre-drill before fixing screws.

Fix the turn buttons (**No. 28**) to the top and bottom of the Secondary Door using 2x30mm screws.

*These turn buttons help keep your doors straight during high and low levels of moisture content in the air.

2x30mm Screws

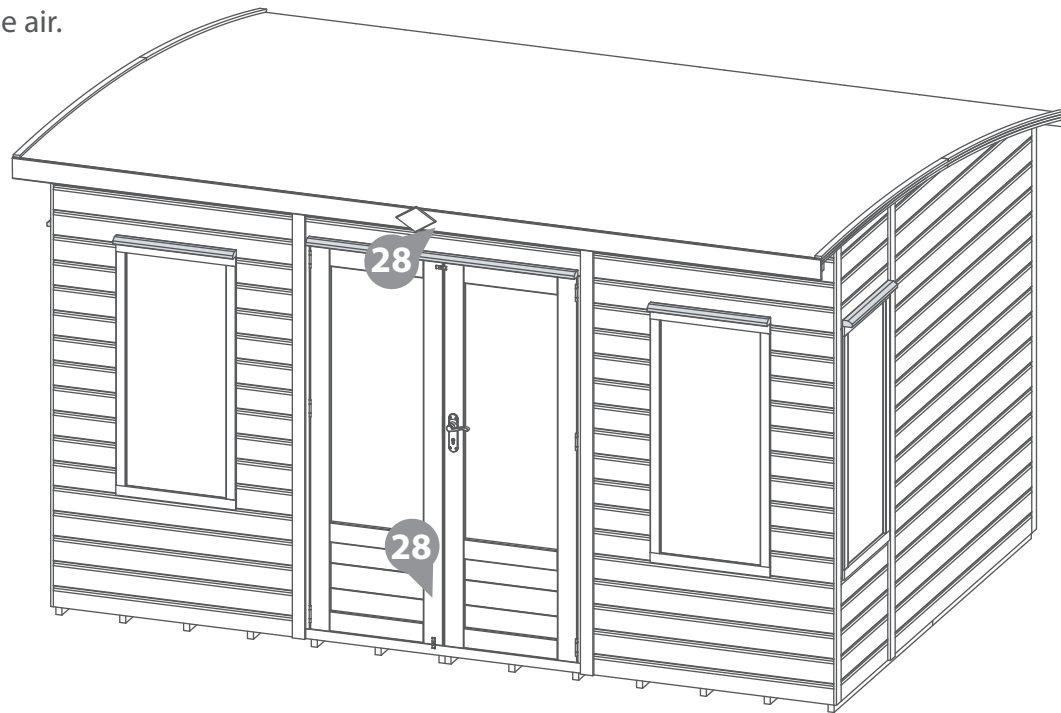
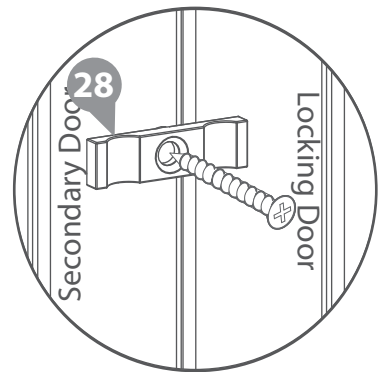

Step 24

Once constructed, apply a preserving treatment and a waterproofing treatment to your garden building as soon as possible. This will help to protect your building and prevent decay.

See page 14 for a full guide and instructions.

Once fully treated, score around the protective covers on the glazing and carefully peel the coverings back.



Apply treatment.



Score and peel.

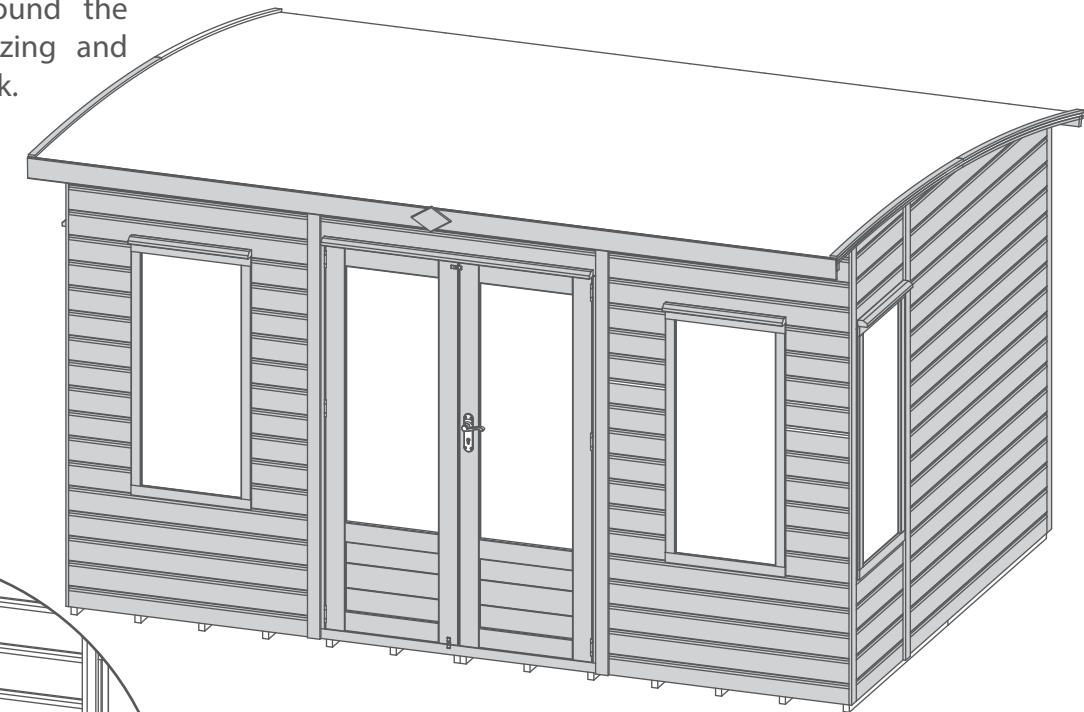
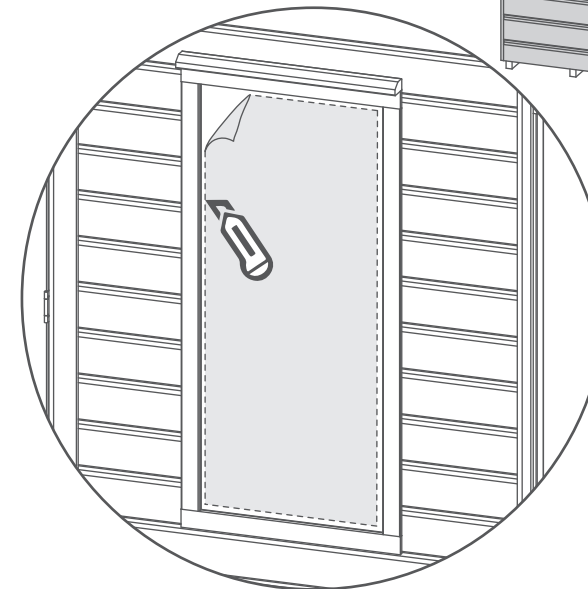

LEAVE US A REVIEW...



Want to share your experience with us?
Leave us a review on Feefo, TrustPilot or Google.

Your reviews help other people find and trust our business, as well as helping to play an important role in our growth and improvement!

TREATING YOUR GARDEN BUILDING

Preservation of wood that's outdoors is vital. A little early care will help protect your garden building, improve its appearance and ensure maximum longevity. Insects, moisture, salt, and changing weather can have dramatic effects on the stability and appearance of your garden building. Once your building is installed, you've checked it over and you're happy with it, you can take a few basic precautions to prepare it for the elements. Treating your garden building helps prevent decay and, by repelling water, discourages the growth of moulds and fungi that could jeopardise the structural integrity of the wood.

Dip Treated buildings - Require a preservative treatment to protect against rot and decay and a waterproof treatment to prevent water ingress
Pressure Treated buildings - Require a waterproof treatment to prevent water ingress
Log Cabins/Insulated Garden Rooms - Are supplied untreated and require a preservative and waterproofing treatment.



ANY QUESTIONS?
Scan the QR code to contact us via our customer portal.

To apply a preservative and water proofing treatment (pressure treated products do not require a preserver), follow the manufacturer's instructions but in principle, stick to the following steps:

- ✓ Wear latex or rubber gloves, eye protection and (if spraying) a mask.
- ✓ Prepare the wood, by sanding down any ridges or inconsistencies in the wood, smoothing out knots and end-cuts.
- ✓ Choose a dry day to treat your garden building. If you're spraying rather than brushing paint on, avoid a windy day.
- ✓ Be sure you can safely reach all the sections you need to paint - and if you need a ladder, make sure it's safely positioned before climbing. Lay dust sheets around to avoid paint splatters on your base or surrounding plants.

- ✓ Tape around windowpanes to avoid smears when you're painting the frames.
- ✓ Keep pets and small children out of the way. The last thing you want is to have fur on your garden building paint, or little painted footprints all over your garden and home.
- ✓ Fill any gaps in the building's body with caulk or wood filler to prevent water and draughts getting in. Silicone based caulk is flexible and will move with the timber when temperature and humidity change. Allow to dry completely before treating. A handy tip for finding gaps is to go into your garden building and look for light leaking through joints and frames. If light gets in, then so will water.
- ✓ Liberally apply at least two coats of the treatment products with a brush or spray, taking care to allow the first coat to completely dry before applying the second.
- ✓ Make sure the solution permeates the whole of the surface area, especially around natural cracks, end cuts and nail/screw holes.



APPLY WOOD TREATMENT
IMMEDIATELY
AFTER ASSEMBLY

PLEASE SCAN HERE TO
SEE TREATMENT VIDEO:



1 Perimeter

Check around the perimeter of your product to ensure there are not trees or plants that are in contact with or overhanging the building. This can affect airflow and overhanging trees, or branches can damage the roof, it is advised to keep plants at a distance.

2 Repair

Inspect the interior and exterior of the product to look for splits, cracks, and holes. Although this is a natural occurrence it can be prevented. A wood filler can be used to close the splits, cracks, and holes.

3 Roof

Check your roof regularly for tears, splits, damaged wood and fallen debris. If you notice any of this immediate repair is critical.

4 Doors & Windows

Expansion and contraction can cause doors and windows to stick or become difficult to open. Small adjustments to the hinge position can be made to the doors and windows to allow free movement.

5 Oil

Hinges can seize up over time, apply lubricant to the hinges and locks annually.

6 Screws & Bolts

It is advised to check all screws and bolts and tighten any loose you might find. For log cabins specifically the storm braces will require loosening. During humidity and temperature changes (seasons) to allow expansion and contraction to prevent gaping, twisting, popping, and warping.

7 Wash

At least once a year, give the outside of you building a good wash, to remove cobwebs, leaves, or any other dirt that may accumulate on the exterior.

8 Airing

Airing your product regularly prevents the build up of condensation which can cause the timber to rot and mould. Condensation can build up over time or daily, it is caused by a rise and fall in temperature. Leaving doors and windows open regularly can help combat the natural moisture build up.

9 Clean & Tidy

It is good practice to clean the inside and outside of your product regularly. Clear out the contents, sweep the floor, remove dirt and cobwebs. Check for areas of damp and investigate the cause to remove and prevent future occurrences. Check the ground around your product for build up of debris such as leaves, remove and ensure there is clear ventilation underneath the floor.

Additional Playhouse Maintenance:

It is recommended that the following checks and maintenance are carried out at the beginning of each season as well as at regular intervals during the usage season.

- Check all nuts /bolts/ screws for tightness and tighten when required.
- Check for movement / opening of wood giving rise to protrusion of nail heads and tips.
- Check hinges.
- Replace defective parts in accordance with the manufacturers instructions.
- Check any crossbeams, suspensions and anchors.
- If a swing is included; check the swing seat, chains and ropes.

IF THESE CHECKS ARE NOT CARRIED OUT THE ACTIVITY TOY COULD BECOME A HAZARD

All our garden buildings have been designed and manufactured with care and attention to be the perfect addition to your outdoor space. To ensure you do get the best out of your new garden building and to increase the longevity we advise that you follow the product instructions and our manufacturer's recommendations as detailed below. Thank you for choosing a Mercia Garden product!

1 Choosing the most suitable location for your garden building...

A minimum of 60cm should be left around the perimeter of your garden building to allow access for maintenance, annual treatment and to allow air flow around the building.

Where possible you should avoid placing your garden building underneath large trees to prevent the tree causing damage to the building.

2 Preparing the base for your garden building...

All our buildings must be built on a firm, level base to ensure the longevity of the building and prevent the wood from distorting. We recommend either concrete, concrete slabs or a wooden base, such as our 'Portabase'.

The base should be slightly smaller than the external measurement of the building, i.e. the cladding should overlap the base, creating a run off for water and preventing water from pooling underneath the building.

We also recommend that the floor of the garden building is a minimum of 25mm above the surrounding ground level to avoid flooding.

3 After installation...

Once your garden building has been installed, it will need to be treated within 14 days (weather permitting) and annually to prevent the timber from deteriorating and to waterproof it. This is required to maintain the anti-rot guarantee.

Dip Treated buildings - Require a preservative treatment to protect against rot and decay

and a waterproof treatment to prevent water ingress.

Pressure Treated buildings - Require a waterproof treatment to prevent water ingress.

Log Cabins/Insulated Garden Rooms - Are supplied untreated and require a preservative and waterproofing treatment.

We also recommend using a silicon sealant on the inside and outside of the windows as soon as possible after assembly and treatment to fully seal the windows.

Roofing felt/covering should be checked annually and replaced or fixed accordingly.

4 General maintenance and wood characteristics

As wood is a natural material it may be affected by the following:

Shrinkage and warping - The timber used in the construction of your garden building will have retained some of its natural moisture content. The moisture content of the timber will vary, depending upon prevailing environmental conditions, which will result in the components either naturally expanding or contracting. As the components dry out, shrinkage may occur. A good waterproofing treatment from the start is the best protection to minimise the effect of moisture loss/intake.

In extended periods of very warm weather getting some moisture to the building will help the overall balance. You can do this by spraying it down lightly with a garden hose. In contrast, after snow fall try to remove the snow as best as possible from the roof to prevent moisture intake and to remove the extra weight.

Top tip - using a garden brush will help you to reach the highest part of the building to remove snow and any debris left from bad weather.

Damp and mould - During the winter months, cold and damp conditions can result in an increased amount of moisture within your garden building, especially when used infrequently. Condensation can form on the timber and other items stored within your garden building. If left this moisture is likely to cause mould and mildew.

To prevent the build-up of moisture, we recommend leaving the door or windows of your building open from time to time, to allow the fresh air to circulate. We also advise against storing wet or damp items in your garden building as this will also increase the level of moisture in the building. If mould or mildew does start to form within your building we recommend using an anti-mould cleaner to remove it and to prevent it spreading, which if left untreated could permanently damage your garden building.

Splits, cracks and knots - You may notice small splits and cracks in some components or holes may appear where knots shrink and fall out. This will not affect the structure of your Garden building however, if you wish to fill them this can be easily done using any good quality wood filler.

Sap - is naturally occurring in wood and may appear in some boards of your garden building. If you wish to remove the sap, we advise waiting until it is dry and then using a sharp knife to carefully remove it. If the removal of the sap causes a hole in the timber, we recommend using a good quality wood filler to fill it.

For more handy hints and tips on how to care and maintain your garden building please refer to the MGP Customer Portal at www.mgplogistics.co.uk

Any further questions?

Contact our
Customer Service Team via the MGP
Customer Portal at:
www.mgplogistics.co.uk

1

Manufacturer's Warranty

All Mercia Garden Products are supplied with a 1 year warranty on all parts against manufacturing defects.

This warranty does not cover movement, warping or splitting of timber products over time.

This warranty will be voided if any of the following occur:

1. The building has been customised or modified/adapted in any way.
2. The person claiming is not the original purchaser of the building.
3. Any damage has been caused by or as a result of misuse.
4. The building has not been maintained and cared for in accordance to our advisories and manufacturer's recommendations.
5. The building has not been treated annually or as per the manufacturer's recommendations, please ensure receipts are kept to validate this claim.
6. The building has not been erected, fitted or installed as per the supplier instructions.
7. The building has not been erected on a suitable sized firm flat, solid level concrete/slab base or placed on pressure treated bearers.
8. The building is or has been placed with 2 feet (600mm) of any obstructions (walls, trees, plants, fences etc.) which can allow moisture to penetrate the timber.
9. The roofing felt has been incorrectly fitted or damaged, allowing water ingress, or has not been properly maintained.
10. Any windows and joints have not been sealed, inside and out, with silicone or other watertight sealant.
11. Any timber has been cut, pierced or drilled without subsequent application of approved cut-end treatment.

2

Anti-rot Guarantee

Mercia Garden Products offer a 10 year anti-rot guarantee on all dip treated (a preparatory treatment) and 15 years on all pressure treated products. This guarantee covers solid timber against rot, decay, blue stain and insect attacks.

To validate the guarantee, the building must be treated (as detailed within manufacturer's recommendations) within 14 days (weather permitting) of assembly and annually thereafter.

This guarantee does not cover movement, warping or splitting of timber products over time.

This guarantee will be voided if any of the following occur:

1. The building has been customised or modified/adapted in any way.
2. The person claiming is not the original purchaser of the building.
3. Any damage is caused by or as a result of misuse.
4. The building has not been maintained and cared for in accordance to our advisories and manufacturer's recommendations.
5. The building has not been treated annually or as per the manufacturer's recommendations, please ensure receipts are kept to validate this claim.
6. The building has not been erected, fitted or installed as per the supplier instructions.
7. The building has not been erected on a suitable sized firm flat, solid level concrete/slab base or placed on pressure treated bearers.
8. The building is or has been placed with 600mm of any obstructions (walls, trees, plants, fences etc.) which can allow moisture to penetrate the timber.
9. The roofing felt has been incorrectly fitted or damaged allowing water ingress, or has not been properly maintained.
10. Any windows and joints have not been sealed, inside and out, with silicone or other watertight sealant.
11. Any timber has been cut, pierced or drilled without subsequent application of approved cut-end treatment.



REGISTER FOR YOUR
ANTI-ROT
GUARANTEE TODAY

PLEASE SCAN HERE:

