

**0619AXNE3326HGDD2SW-V2**  
**19MM 3.3M X 2.6M APEX LOG CABIN.**

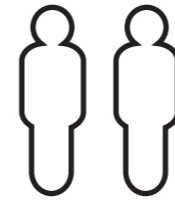

**x2**  
 All buildings should be erected by two adults.



Winter = High Moisture = Expansion  
 Summer = Low Moisture = Contraction

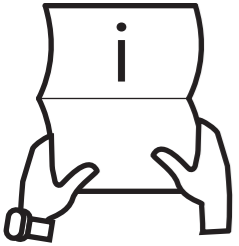

**BEFORE YOU START PLEASE READ THE INSTRUCTIONS CAREFULLY**

- Check the pack and make sure you have all the items listed in the parts list provided.
- When you are ready to start, make sure you have the right tools at hand (not supplied - see the equipment list on next page).
- Ensure there is plenty of space and a clean dry area for assembly.
- Ensure you have enough time to build the product to ensure the building is water tight.



**2mm Drill bit**

For ease of assembly, you **MUST** pilot drill all screw holes and ensure all screw heads are countersunk.



**CAUTION**

Every effort has been made during the manufacturing process to eliminate the prospect of splinters on rough surfaces of the timber. You are strongly advised to wear gloves when working with or handling rough sawn timber.

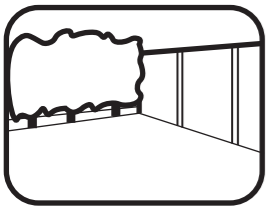

**LOCATION FOR YOUR GARDEN BUILDING**

A minimum of 600mm should be left around the perimeter of your garden building to allow access for maintenance, annual treatment and to allow air flow around the building.

Where possible you should avoid placing your garden building underneath large trees to prevent the tree causing damage to the building.

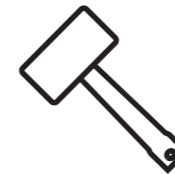

For ease of assembly use a rubber mallet to fit the log boards. Do NOT use a heavy hammer.



Ensure to measure and check dimensions of components and fixings before cutting.

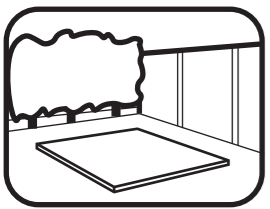

**BUILDING A BASE**

When thinking about where the building and where the base is going to be constructed: Ensure that there will be access to all sides for maintenance work and annual treatment. Ensure the base is level and is built on firm ground, to prevent movement. The base should be the same size as the building's floor bearer frame. These base dimensions are given on the first page of the contents. It is also recommended that the floor be at least 25mm above the surrounding ground level to avoid flooding.



It is advisable to use a hand saw when cutting roof and floor boards.

Use a measuring tape to identify the fixings required for each step:

**Screws & Nails**

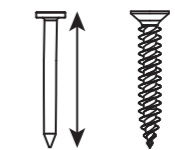

Measure overall length

**Bolts**

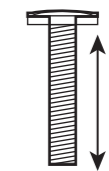

Measure under the head



To ensure log boards are even, use a spirit level to check each layer has been installed correctly.

**TYPES OF BASE**

- Concrete 75mm laid on top of 75mm hard-core.
- Slabs laid on 50mm of sharp sand.
- Wooden base - Levelled / on posts / ground screws.

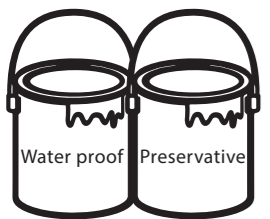

**TREATMENT**

Once your garden building has been installed it will need to be treated within 14 days (weather permitting) and annually to prevent the timber from deteriorating and to waterproof it. This is required to maintain the anti-rot guarantee.

Log Cabins - Are supplied untreated and require a preservative and waterproofing treatment.

**TIMBER**

As with all natural materials, timber can be affected during various weather conditions. For the duration of heavy or extended periods of rain, swelling of the wood panels may occur. Warping of the wood may also occur during excessive dry spells due to an interior moisture loss. Unfortunately, these processes cannot be avoided but can be helped. It is suggested that the outdoor building is sprayed with water during extended periods of warm sunshine and sheltered as much as possible during rain or snow.

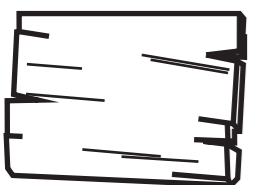

**REGISTER FOR YOUR  
 10 YEAR  
 ANTI-ROT  
 GUARANTEE TODAY**

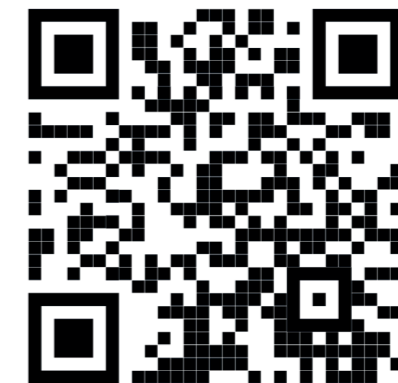

[www.mgplogistics.co.uk](http://www.mgplogistics.co.uk)

In all instances for assistance with your product or to register your anti rot guarantee, please contact us via our customer portal .

Mercia Garden Products Limited,  
 Sutton On Trent, Newark,  
 Nottinghamshire, NG23 6QN



Whilst all products manufactured are made to the highest standards of safety and in the case of children's products independently tested to EN71 level, we cannot accept responsibility for your safety whilst erecting or using this product.

## TO DO LIST

- Find a suitable location to build *(see front cover for further information)*.
- Build a base *(see front cover for further information)*.
- Check the base is flat, level, clear of debris and has 60cm clearance on all sides.
- Check you have the required equipment / tools.
- Check you have all the product items listed *(if you have missing or damaged parts please scan the QR code below to visit our online customer portal)*.
- Install the product as per the step by step instructions within this pack.
- Prepare the product ready for treatment (this may include sanding).
- Apply a preserving and a waterproofing treatment within 14 days of installation *(weather permitting)*.
- Register for your anti rot guarantee *(scan the QR below)*.
- Tidy the build area and dispose of any remaining parts responsibly.
- Maintain your building *(see the manufacturers recommendations at the back of this pack)*.

## EQUIPMENT LIST

- Hammer
- Mallet
- Flat Head Screwdriver
- Drill
- Drill Bit Set
- Phillips and Slotted Bit Sets
- Tape Measure
- Hand Saw
- Spirit Level
- Ladders/Steps
- Stanley Knife/Cutting Tool
- Sand Paper
- Gloves
- Silicone (For Windows Only)
- Sealant Application Gun
- Wood Filler (Optional)
- Timber Preservative Treatment
- Timber Water Proofing Treatment
- Treatment Mixing Stick
- Paint Brush/Sprayer/Roller

## NEED EXTRA SUPPORT

If you are unsure that your base preparation will be suitable, please contact us via our customer portal to discuss this further.

Alternatively, you can visit our website or MGP Logistics Online Portal for some further shededucation.

**Website:**

<https://www.merciagardenproducts.co.uk/sheducation>

**MGP Logistics Online Portal:**

<https://www.mgplogistics.co.uk/>

Here you will find plenty of useful information that'll help with most pre-installation and maintenance queries.

**ANY QUESTIONS?**

Scan the QR code to contact us via our customer portal.

## NOTES

## ACCESSING VIDEO GUIDES...

Some steps within this set of instructions come with an added video guide for your convenience. These can be accessed via the QR code and used to aid you in constructing that step. See below for how to use.

You can also find all the videos on our youtube channel:  
<https://www.youtube.com/@merciagardenproducts8716/videos>

### 1. Find the QR code within the instruction step...

#### Step.....

Parts Needed- No. QTY 1  
No. QTY 1  
No. QTY 1

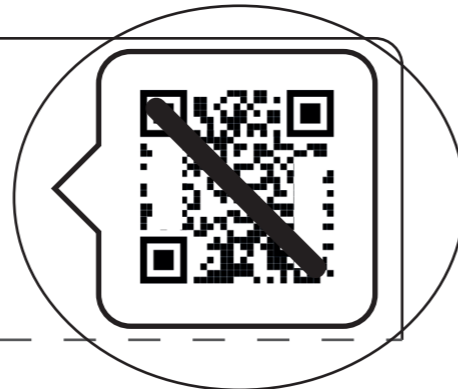

Within the instruction step, there will be an icon in the top right that has a QR code in. This is where the video can be accessed from.

*Please note: not every step has a video guide.*

### 2. Open camera app...

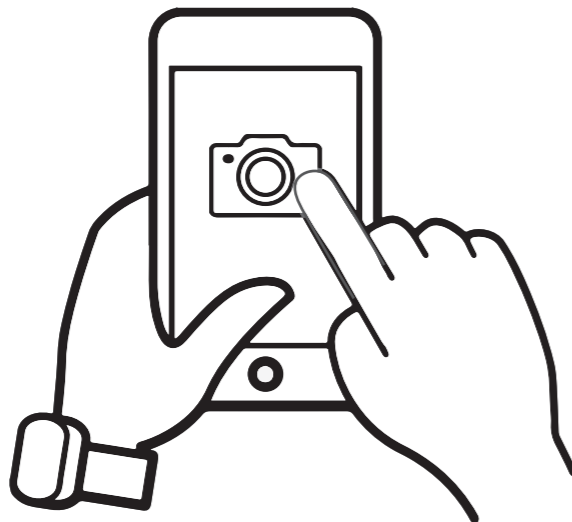

On your personal smart device (phone, tablet etc), open your camera app or QR code scanner app.

## ACCESSING VIDEO GUIDES...

### 3. Scan QR code...



To scan the QR code, hold the camera over the QR code so that it can be seen on the screen. Once the QR code has been registered, follow the prompts on your device to open the video. (This will vary depending on your device.)

*Please note: Ensure to use the back camera of your smart device as this will scan the QR code more accurately.*

### 4. Watch the video...



The video guide will now be displayed on your smart device.

**Disclaimer:** *The Log Cabin constructed in the video guides may be constructed differently to your building. Please ensure to read your instructions carefully to avoid error.*

## 0619AXNE3326HGDD2SW-V2

**Overall Dimensions:** Width = 3445mm  
 Depth = 2636mm  
 Height = 2642mm

**Base Dimensions:** Width = 3104mm  
 Depth = 2403mm

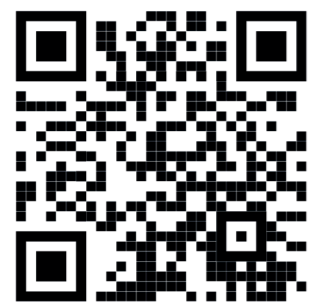
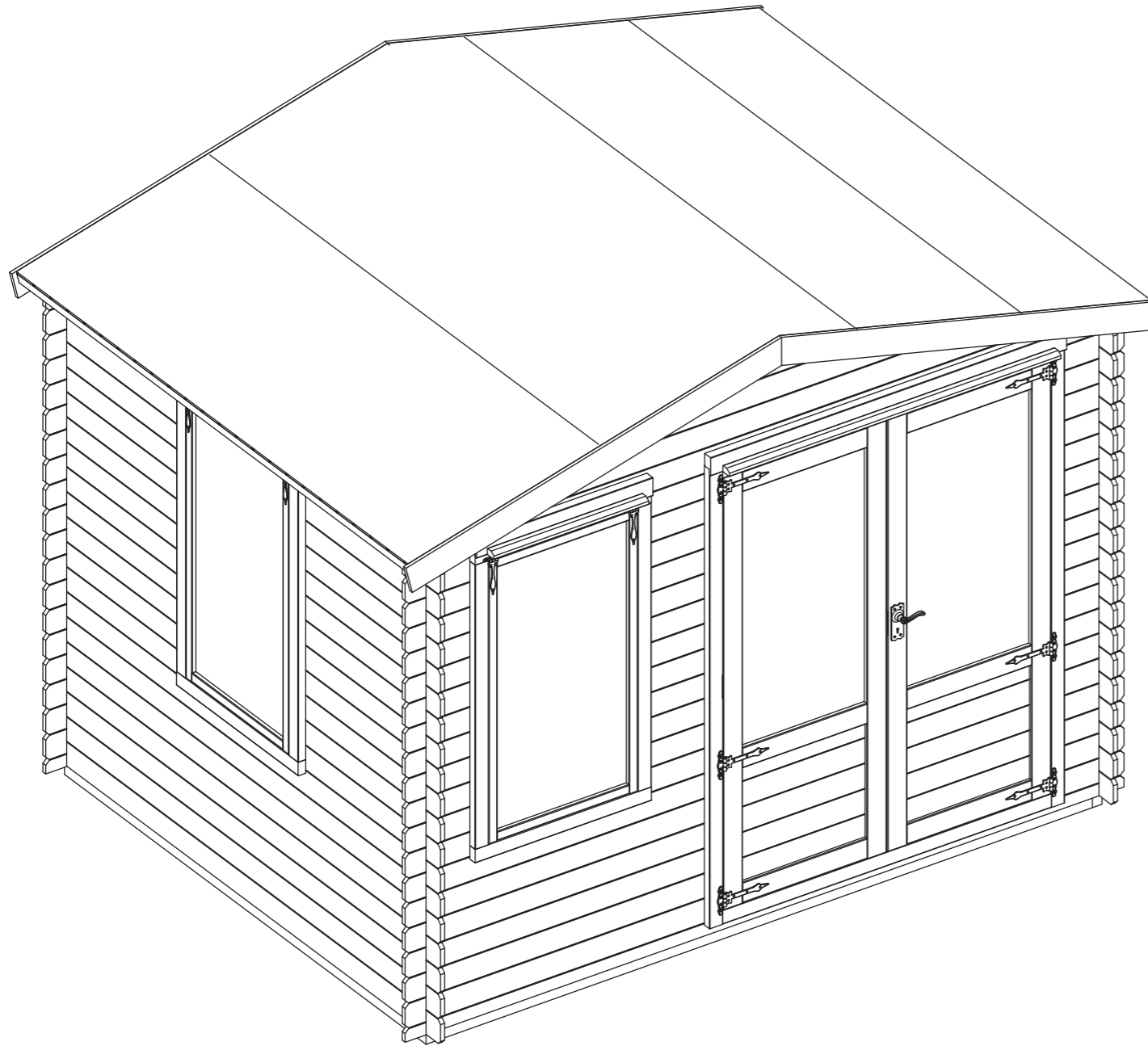

### Missing parts?











Scan the QR code to visit our customer portal where you can quickly raise any missing or damaged parts and get a replacement sent out ASAP.



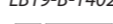
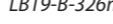





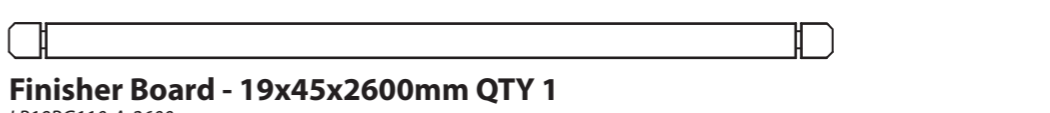

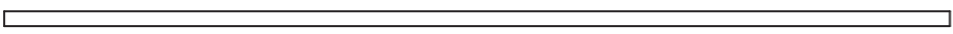
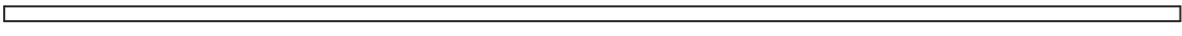
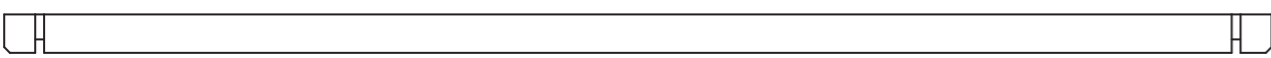

Tip: Labelling your parts, using a pencil and masking tape, may help you to identify them easier when you need them.

NO. 1 STARTER BOARD

### Log Boards Contents:

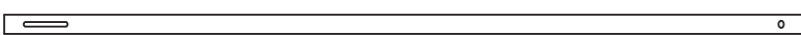
- 1  **Starter Board - 19x66x3296mm QTY 2**  
LB19RT66-A-3296mm
- 2  **Log Board - 19x120x2600mm QTY 25**  
LB19-A-2600mm
- 3  **Log Board - 19x120x3296mm QTY 19**  
LB19-A-3296mm
- 4  **Log Board - 19x120x1402mm QTY 6**  
LB19-B-1402mm
- 5  **Log Board - 19x120x326mm QTY 30**  
LB19-B-326mm
- 6  **Log Board - 19x120x326mm QTY 12**  
LB19-C-326mm
- 7  **Log Board - 19x120x925mm QTY 23**  
LB19-B-925mm
- 8  **Log Board - 19x120x2600mm QTY 1**  
LB19-A-2600mm (Vent cut out)
- 9  **Log Board - 19x120x925mm QTY 1**  
LB19-B-925mm (Vent cut out)
- 10  **Log Board - 19x120x3296mm QTY 1**  
LB19-AD-3296mm (1 x window, 1 x door cut out)
- 11  **Log Board - 19x120x2600mm QTY 1**  
LB19RG110-AD-2600mm (1 x window cut out)
- 12  **Finisher Board - 19x45x2600mm QTY 1**  
LB19RG110-A-2600mm
- 13  **Gable QTY 2**  
AI-0619LOGAX33-G-V1







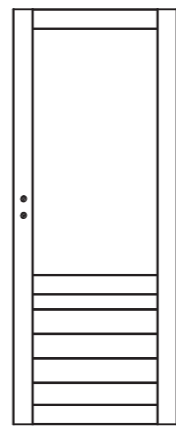
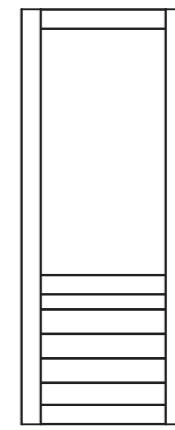
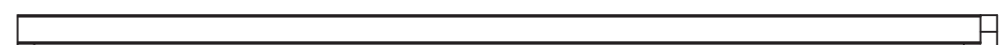
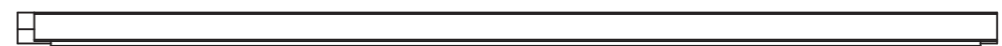

### Fixing Kit Contents:

- **14**  **Floor Bearer - 44x44x2408mm QTY 2**  
*F4444-2408mm-PT*
- **15**  **Floor Bearer - 44x44x3016mm QTY 10**  
*F4444-3016mm-PT*
- **16**  **Purlin - 40x90x2604mm QTY 3**  
*F4090-A-2604mm*
- **17**  **Roof Board - 12x121x1752mm QTY 50**  
*MB12-1752mm*
- **18**  **Floor Board - 12x121x2364mm QTY 29**  
*MB12-2364mm*
- **19**  **Eaves Frame - 27x44x2604mm QTY 2**  
*F2744-2604mm*
- **20**  **Fascia - 12x120x1775mm QTY 4\***  
*S12120-G-1775mm*
- **21**  **Closure Trim - 16x28x2400mm (approx length) QTY 10\***  
*S1628-2400mm*
- **22**  **Storm Brace - 44x27x2000mm QTY 8**  
*F2744-2000mm*
- **23**  **Plastic Vent QTY 4**  
*PI-07-0237*
- **24**  **Felt**
- **25**  **2mm Spacer QTY 5**  
*PI-07-0208 (20x100x2mm)*

*\*This part will be longer than needed and requires cutting to size when used. This will be explained when required within the instruction step.*

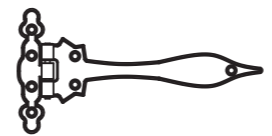
*Note: one piece may be required to be cut into multiple different sizes. Do not dispose of off-cuts until the building is fully constructed as they may be needed in another step.*

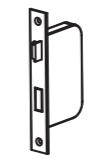
### Door Contents:

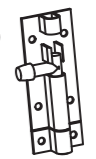
- **26**  **Master Door QTY 1**  
*(Morticed for lock)*  
*AI-06LOGSANGHGMD750X1900-V1*
- **27**  **Secondary Door QTY 1**  
*AI-06LOGSANGHGSD750X1900-V1*
- **28**  **Door Frame Left Upright - 71x70x2065mm QTY 1**  
*AI-0619LOGDUFL-V3* *End View*
- **29**  **Door Frame Right Upright - 71x70x2065mm QTY 1**  
*AI-0619LOGDUFR-V3* *End View*
- **30**  **Door Frame Top - 81x125x1632mm QTY 1**  
*AI-0619LOGDDTF-V3* *End View*
- **31**  **Door Frame Bottom - 71x70x1508mm QTY 1**  
*AI-0619LOGDDBF-V3* *End View*
- **32**  **Door Strip - 16x60x1880mm QTY 1**  
*S1660-1880mm*
- **33**  **Rain Guard - 28x44x1520mm QTY 1**  
*RG2844-1520mm*
- **34**  **9 Inch T-Hinge QTY 6**  
*PI-07-0002*
- **35**  **Handles QTY 1**  
*PI-07-0006 (Pair)*
- **36**  **Mortice Lock QTY 1**  
*PI-07-0017*
- **37**  **Key Plate QTY 1**
- **38**  **Tower Bolt QTY 2**  
*PI-07-0114*

### Window Contents:

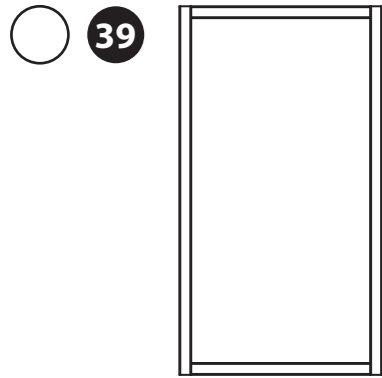

39

#### Window QTY 2

AI-06LOGSANGW684X1244-V1



40

#### Window Frame Left Upright - 71x70x1412mm QTY 2

AI-0619LOGWUFL-V3

End View

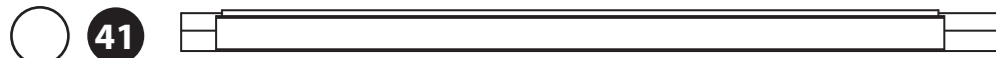

41

#### Window Frame Right Upright - 71x70x1412mm QTY 2

AI-0619LOGWUFR-V3

End View



42

#### Window Frame Top - 81x125x805mm QTY 2

AI-0619LOGSWTF-V3

End View



43

#### Window Frame Bottom - 71x70x805mm QTY 2

AI-0619LOGSWBF-V3

End View



44

#### Rain Guard - 28x44x710mm QTY 2

RG2844-710mm

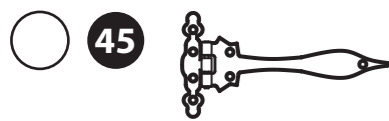

45

#### 6 Inch T-Hinge QTY 4

PI-07-0113



46

#### Casement Stay QTY 2

PI-07-0008

### Screw Pack.

There may be extra screws present in the pack.



60mm Bolt Set x 16



30mm Screw x 78



80mm Screw x 24



30mm Black Screw x 102



70mm Screw x 70



20mm Screw x 8



40mm Screw x 406



Felt Tacks x 200

### Pre-assembly

#### \*Please note:

Each board interlocks at either end in a staggered pattern.

Before securing ensure that the boards are fitted properly in their respective tongue's and groove's.

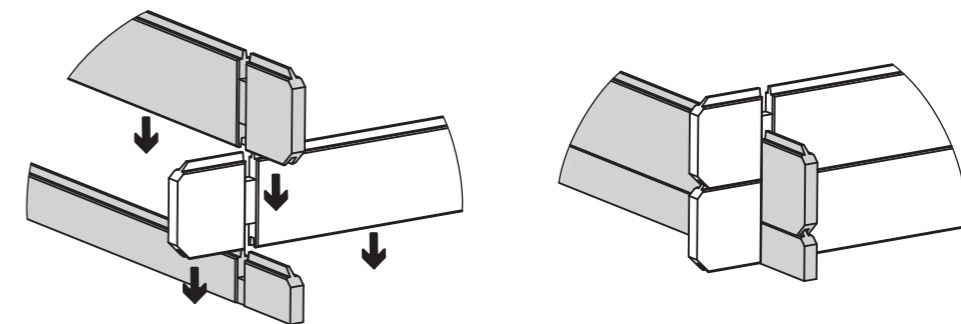

**Step 1**  
**Parts Needed - No. 14 QTY 2**  
**No. 15 QTY 2**

Lay the bearers (**No. 14 & 15**) onto a firm and level base (*free from areas where standing water can collect*) ensuring the bearers are flat and level and the ends are flush, as shown.

Fix the bearers together using 2x70mm screws per corner.

Once secured, ensure the bearers are square by measuring from corner to corner, making sure the measurements are equal. If the bearers are not aligned equally, unscrew, adjust and re-align accordingly.

**8x70mm screws**  
**Important: Pre-drill before fixing screws.**

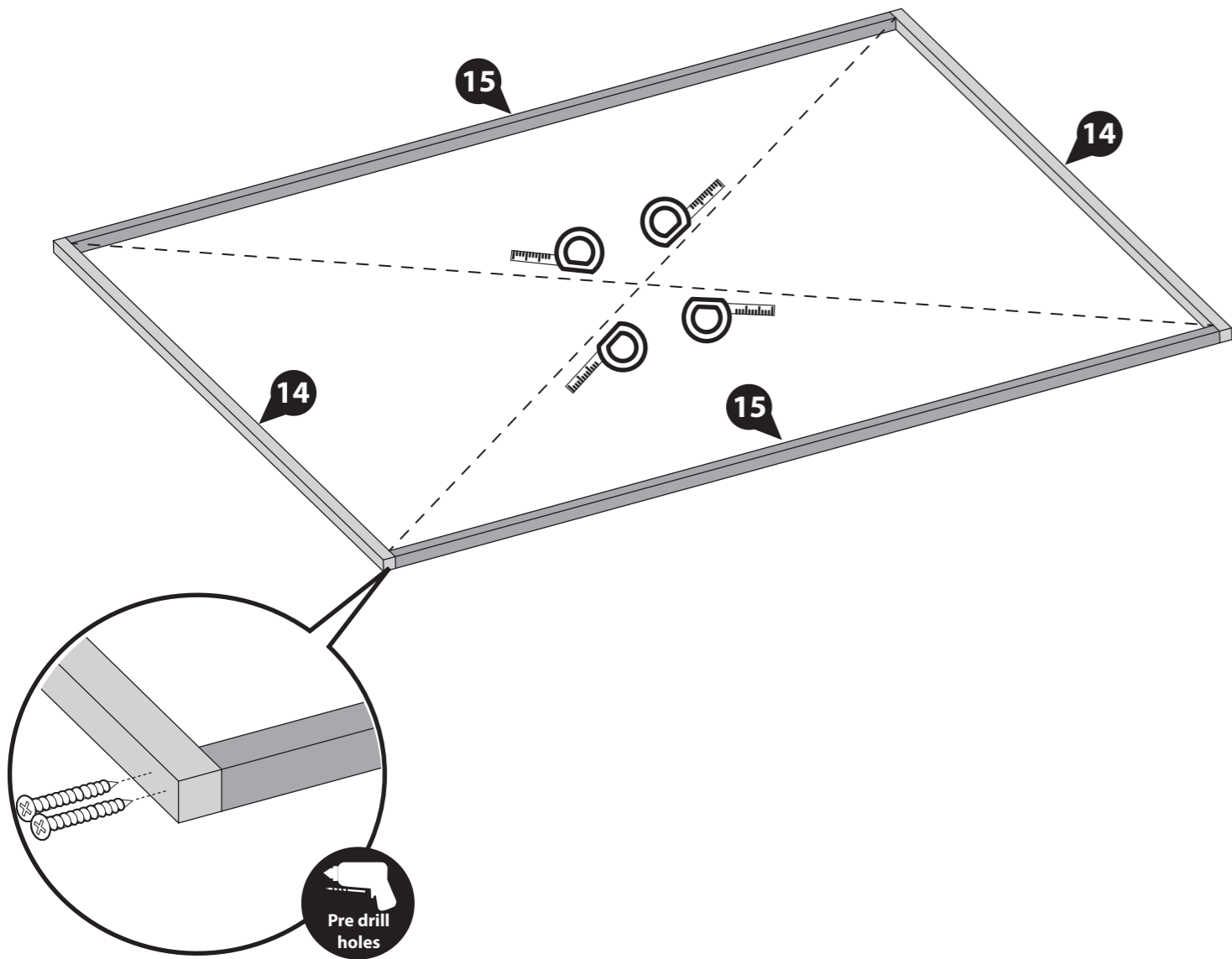
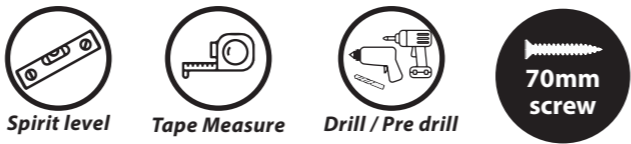

**Step 2**  
**Parts Needed - No. 15 QTY 8**

Following the same method shown in the previous step, arrange the remaining bearers (**No. 15**) inside the assembled frame, ensuring each piece is flush and level.

**\*Ensure there is an equal amount of space between each bearer.**

Secure each of the bearers in place by screwing through the outside framing into the framing behind using 2x70mm screws for each end of the bearer, as shown.

**32x70mm screws**  
**Important: Pre-drill before fixing screws.**

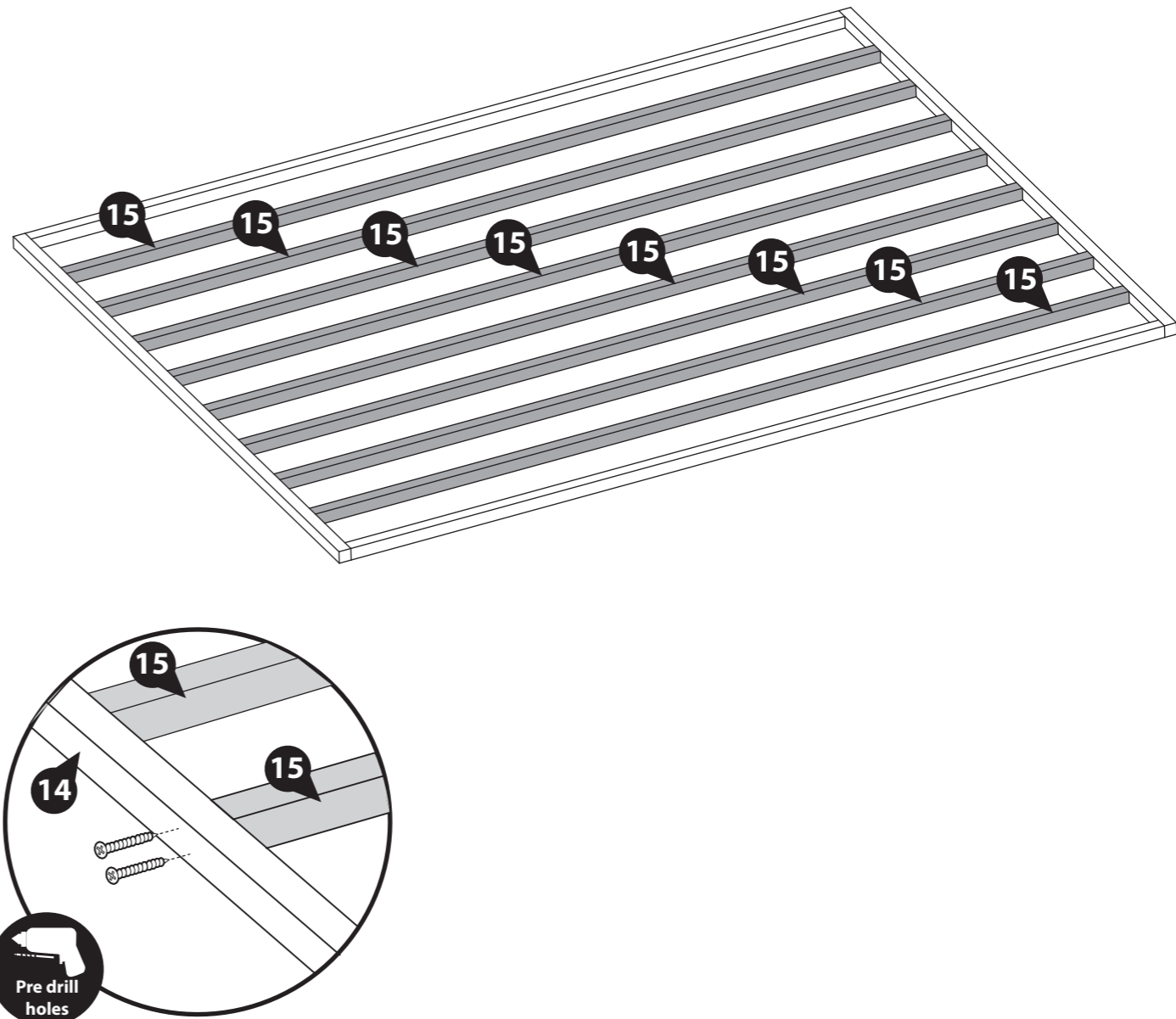
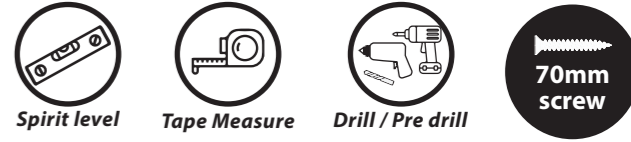

**Step 3**

**Parts Needed - No. 1 QTY 2**  
**No. 2 QTY 2**

Place the starter boards (**No. 1**) on to the front and back of the assembled bearers and lightly position the first two log boards (**No. 2**) into the notches as shown.

Ensure the boards sit square on the base using the same method used in Step 1. Measure corner to corner, making sure the measurements are equal.

Once the boards are square, lift up the log boards (**No. 2**) and fix the starter boards in place by screwing through the notch into the bearer below, using 1x70mm screw per notch.

**Note: Use a mallet and a scrap piece of wood to gently persuade the log boards into place.**

**4x70mm screws**  
**Important: Pre-drill before fixing screws.**

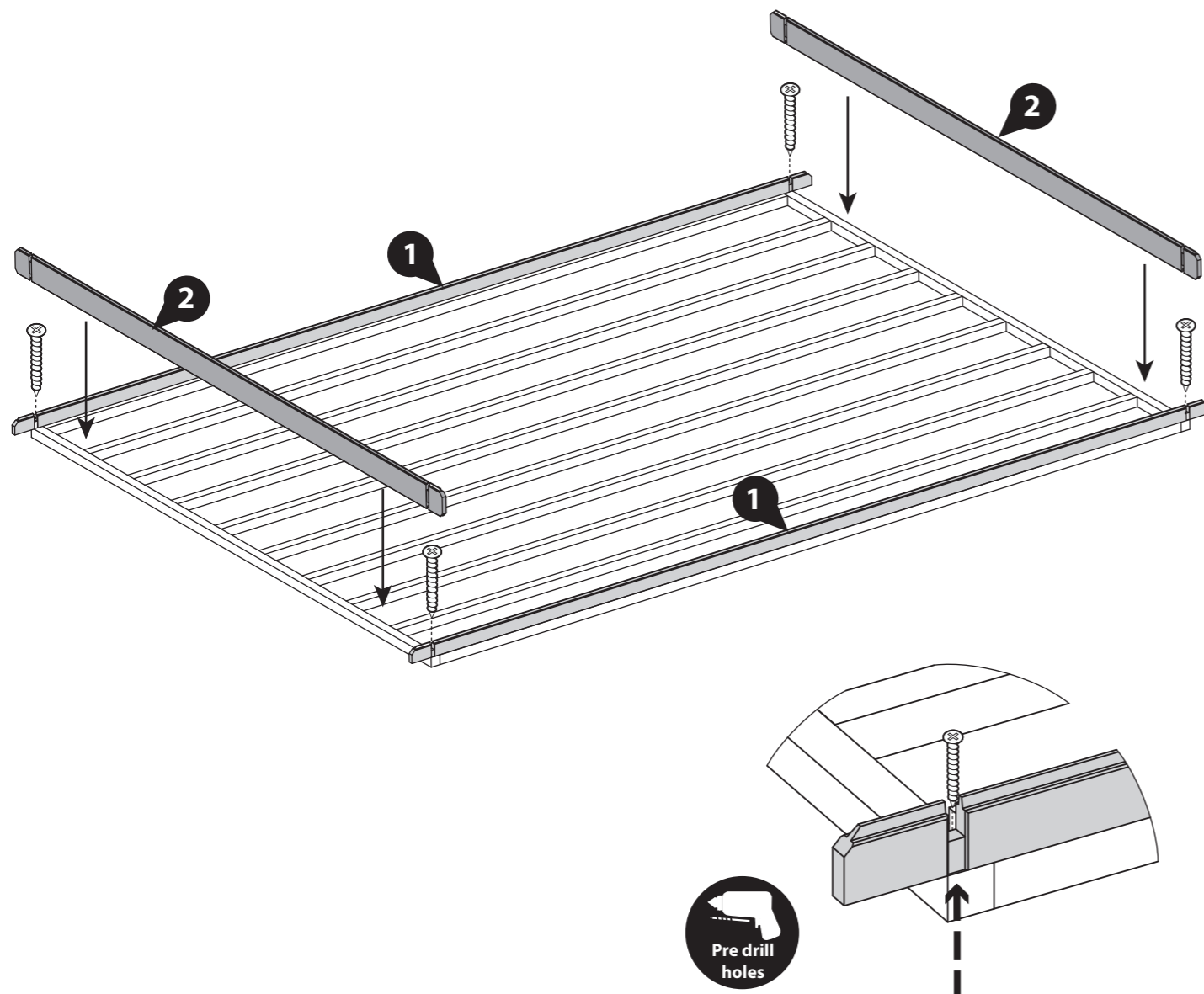

**Step 4**

**Parts Needed - No. 2 QTY 12**  
**No. 3 QTY 6**  
**No. 4 QTY 6**  
**No. 5 QTY 6**

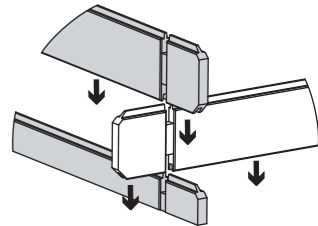

Following the method shown in the illustration, lay the first 6 boards (**No. 2, 3, 4 & 5**) off of the starter boards to create your first level.

**\*Ensure that the boards are level and flush with each other as you lay each one.**

Start by placing the front and back boards, interlocking them with the side boards. Then place the next side boards, interlocking with the front and back boards. Continue this method until you have placed **6 boards off of the starter boards on each side**, as shown.

*Please note: The short boards at the front of the building can be placed on either side depending on where you'd like your doors to be positioned.*

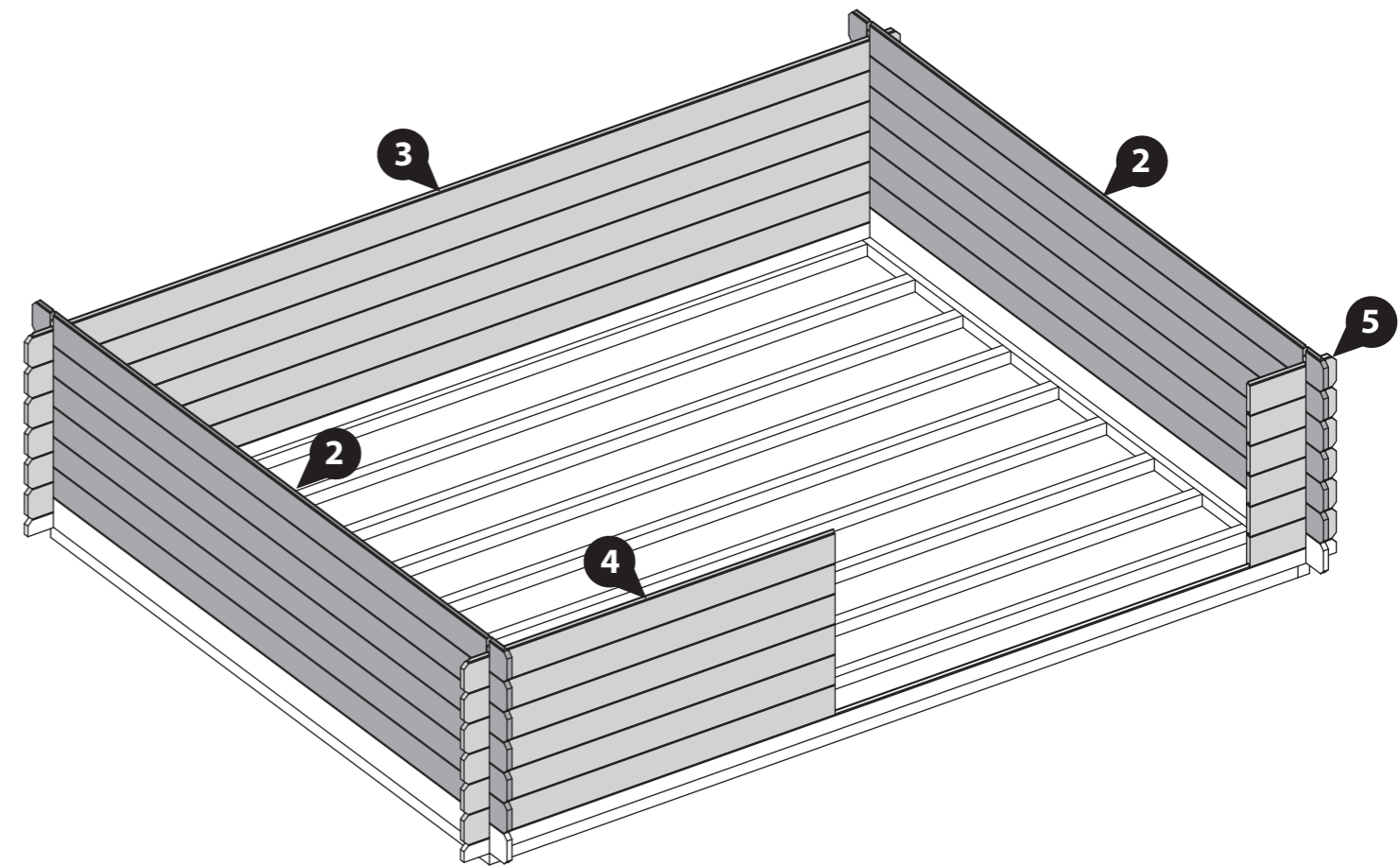



**Step 5**

- Parts Needed - No. 28 QTY 1**
- No. 29 QTY 1**
- No. 30 QTY 1**
- No. 31 QTY 1**

Arrange the left, right, top & bottom door frames (**No. 28, 29, 30 & 31**) onto a flat and level surface.

Secure the top and bottom frames to the uprights using 2x80mm screws per corner, ensuring the screws do **NOT** protrude through the front of the door framing.

**8x80mm screws**  
**Important:** Pre-drill before fixing screws.

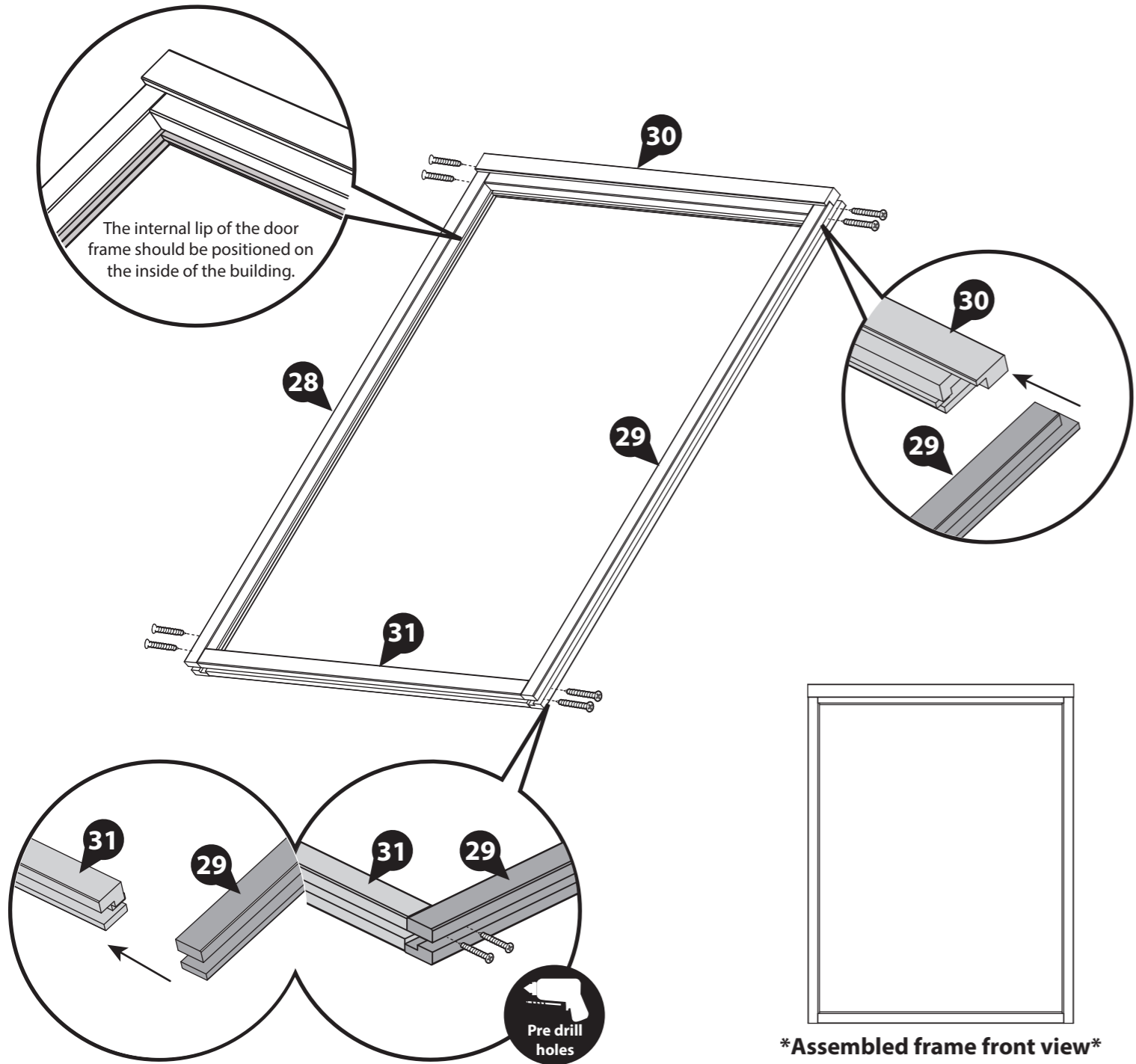

**Step 6**

Once you have laid 6 log boards (off of the starter board) up the door section, slide the assembled door frame over the boards, ensuring to rest the frame on top of the starter board. *If you have not yet assembled your door frame, please refer to step 5.*

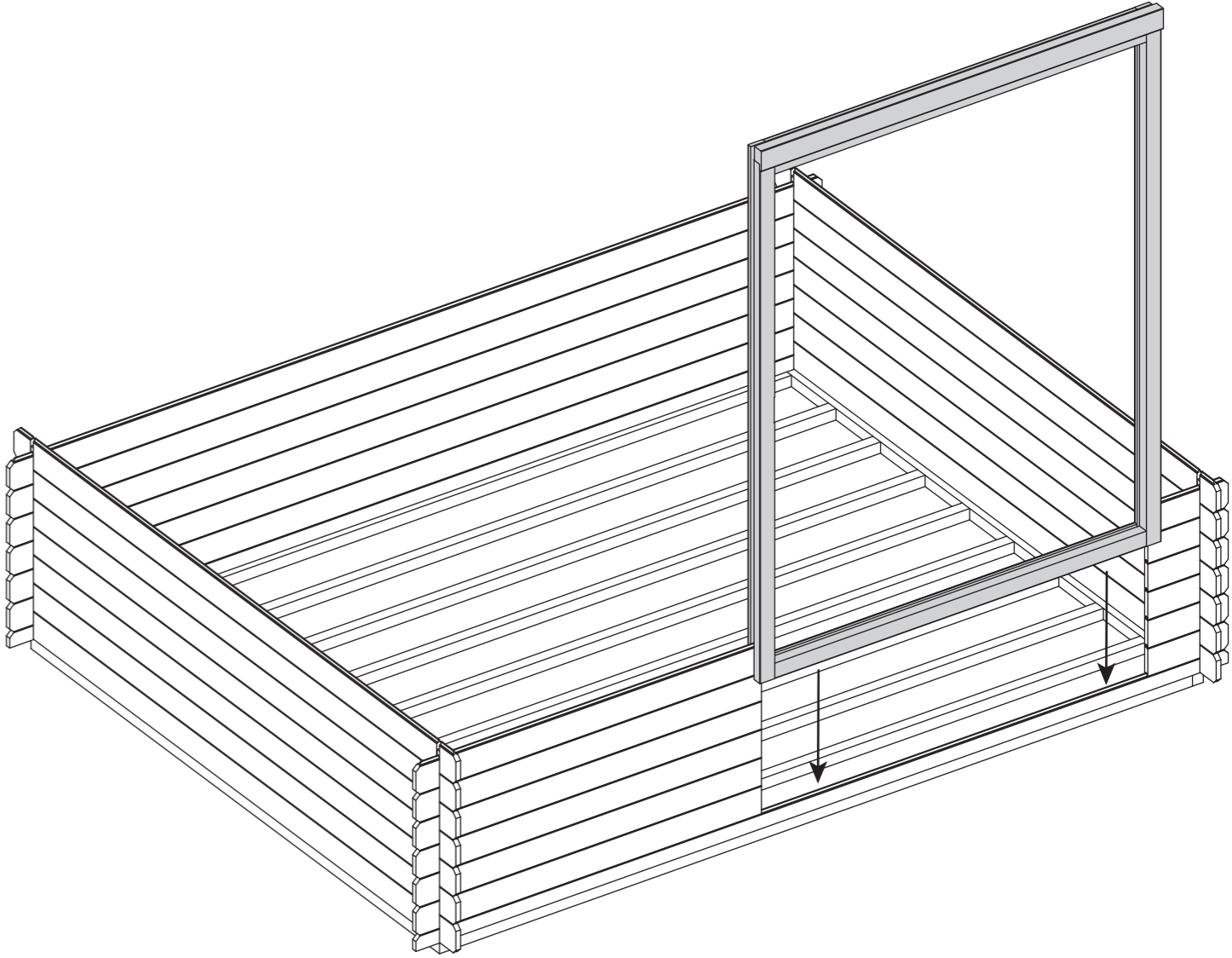

**Step 7**

- Parts Needed - No. 2 QTY 6**  
**No. 3 QTY 6**  
**No. 5 QTY 12**  
**No. 6 QTY 6**  
**No. 7 QTY 12**

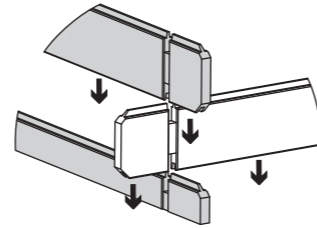

Following the method shown in the illustration, lay the next 6 boards (**No. 2, 3, 5, 6 & 7**) onto the log cabin to create your second level.

*\*Ensure that the boards are level and flush with each other as you lay each one.*

*Please note: The short boards at the side of the building can be placed on either side depending on where you'd like your window to be positioned.*

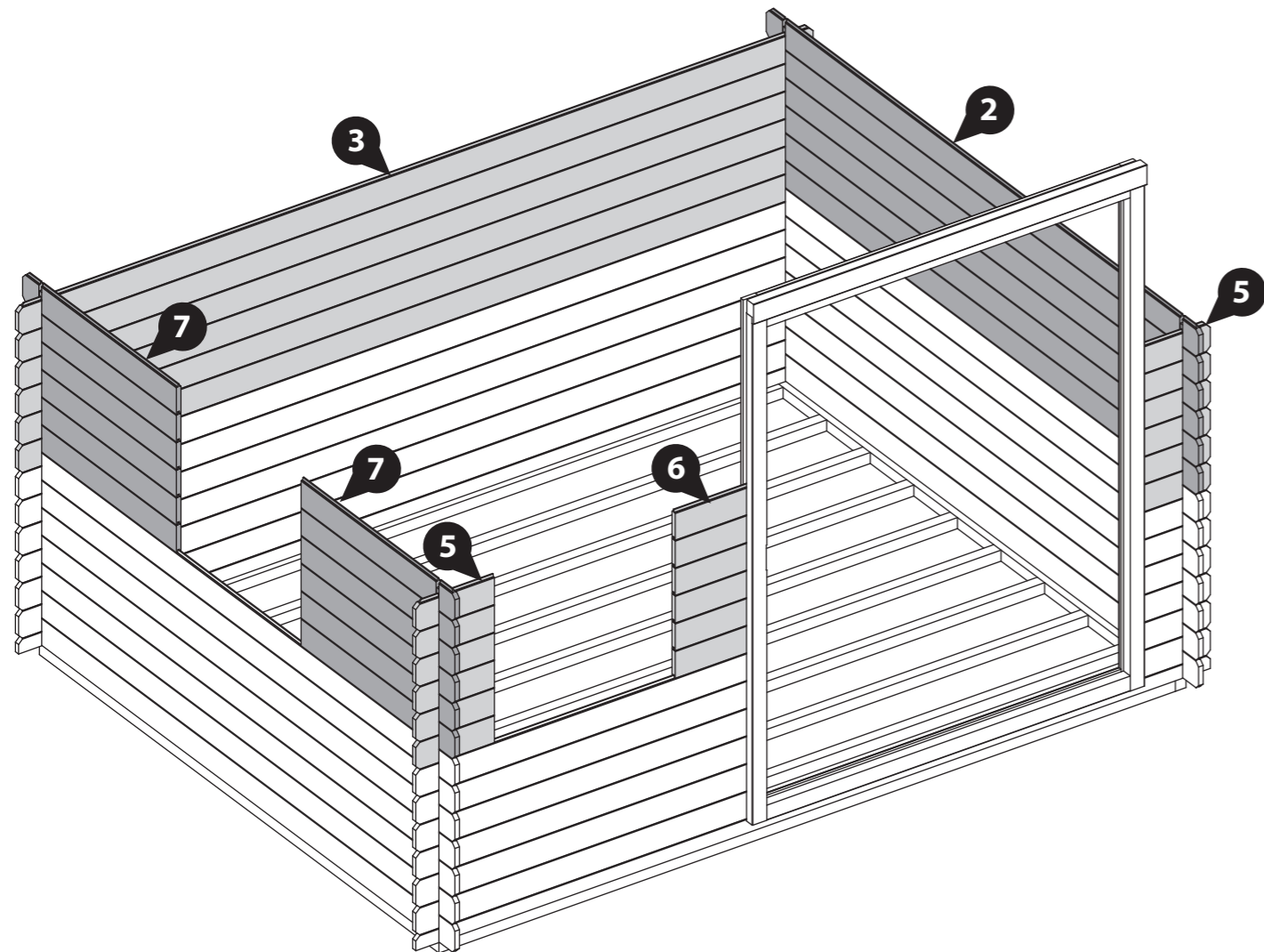

**Step 8**

- Parts Needed - No. 40 QTY 2**  
**No. 41 QTY 2**  
**No. 42 QTY 2**  
**No. 43 QTY 2**

Arrange the left, right, top & bottom window frames (**No. 40, 41, 42 & 43**) onto a firm and level surface. Secure the top and bottom frames to the uprights using 2x80mm screw per corner, ensuring the screws do **NOT** protrude through the front of the window framing.

Use this method to assemble two window frames.

**16x80mm screws**  
**Important: Pre-drill before fixing screws.**

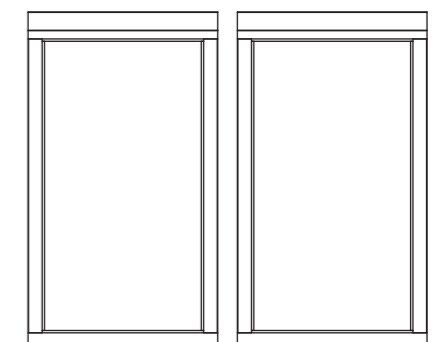
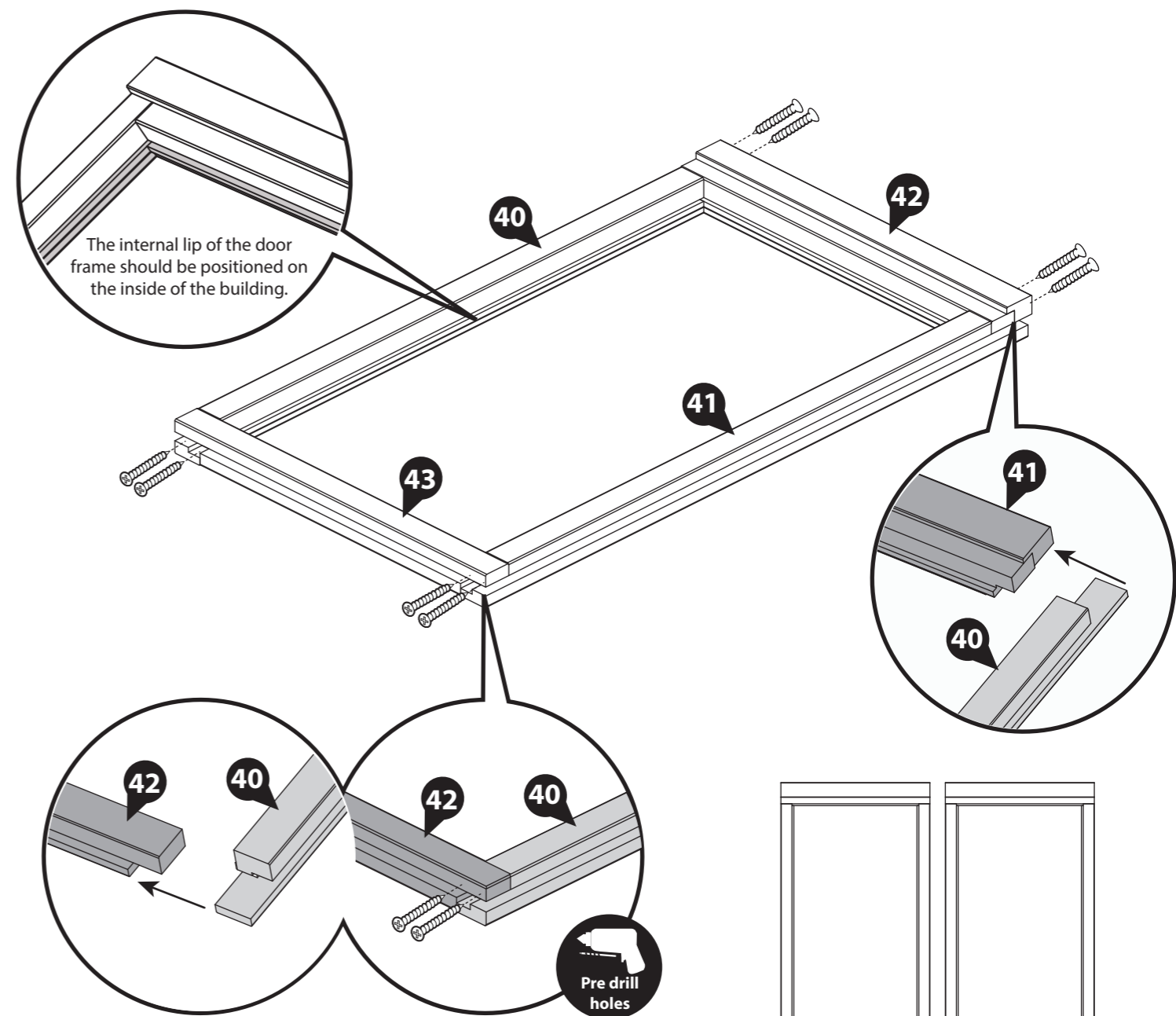

**\*Assembled frame front view\***

**Step 9**

Once you have laid 6 log boards up the window sections, slide the assembled window frames over the boards, ensuring to rest the frame on top of the boards below. *If you have not yet assembled your window frames, please refer to step 8.*



Rubber Mallet

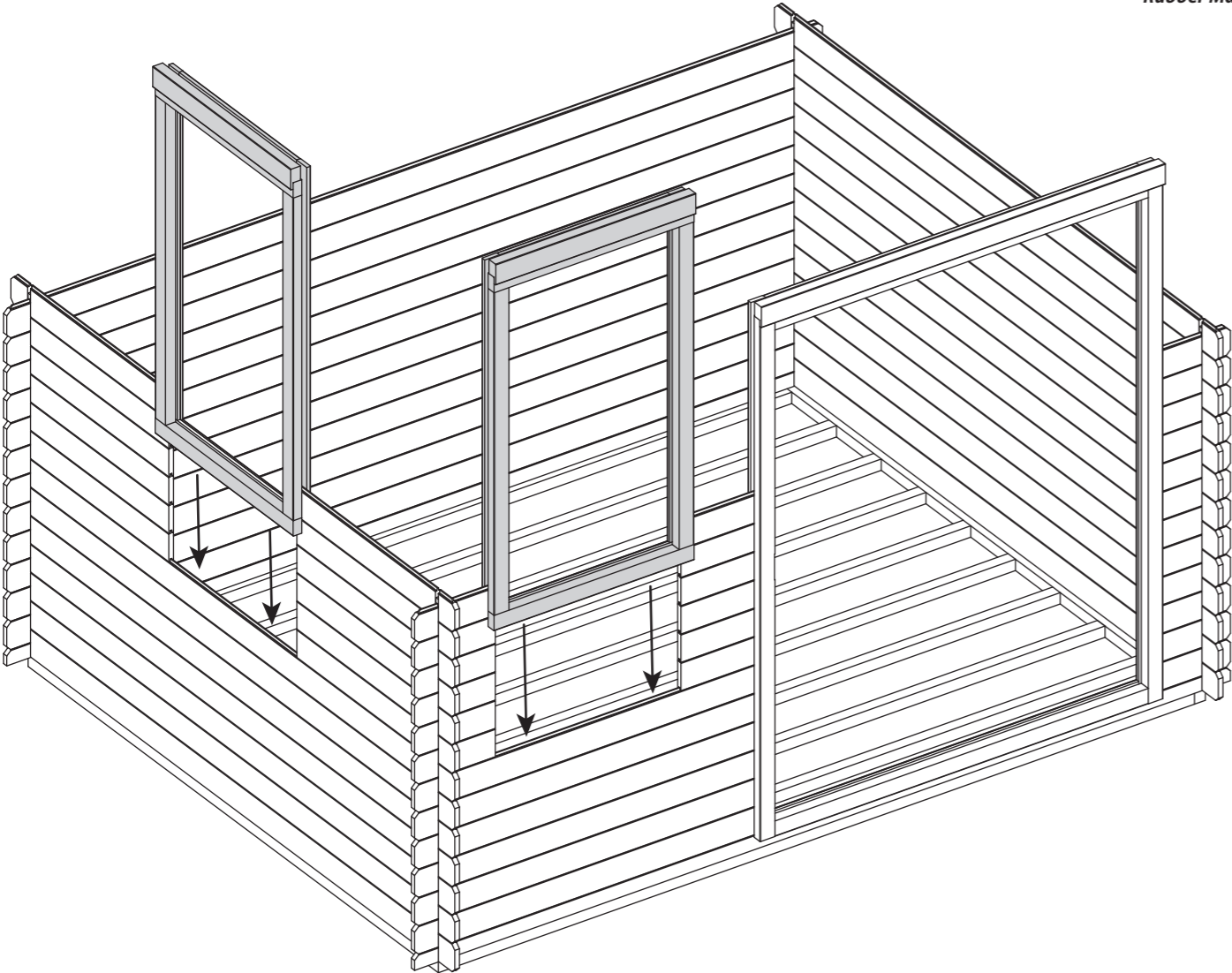

**Step 10**

- Parts Needed - No. 8 QTY 1**
- No. 9 QTY 1**
- No. 23 QTY 4**

Lay the Log Boards (No. 8 & 9) onto a flat and level surface and locate one Vent (No. 23) into each vent hole, as shown. Secure in place using 2x20mm screws per Vent.

Flip the Log Boards (No. 8 & 9) over and position the remaining Vents (No. 23) into the opposite side of the Vent holes. Fix in place using 2x20mm screws per Vent.

On one side of each gable, the vent will need to be slightly offset to an angle to ensure the screws do not collide.

**8x20mm screws**  
**Important:** Pre-drill before fixing screws.



Drill / Pre drill



20mm screw

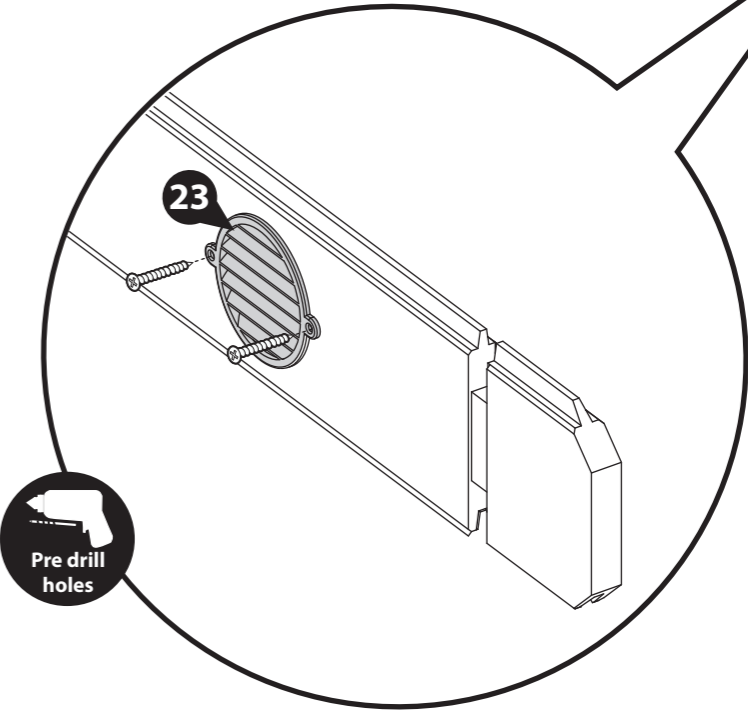
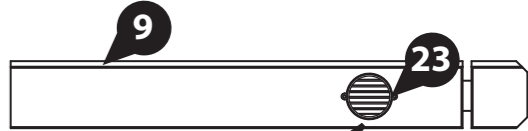
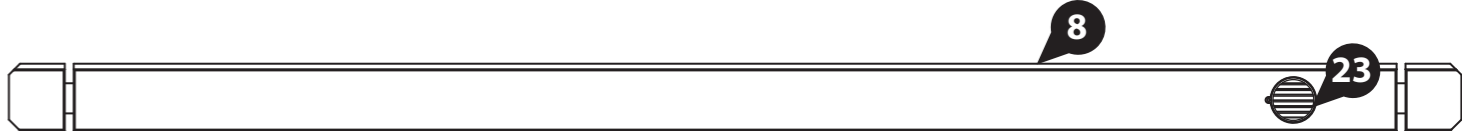

Pre drill holes

**Step 11**

- Parts Needed - No. 2 QTY 5**  
**No. 3 QTY 6**  
**No. 5 QTY 12**  
**No. 6 QTY 6**  
**No. 7 QTY 11**  
**No. 8 QTY 1**  
**No. 9 QTY 1**

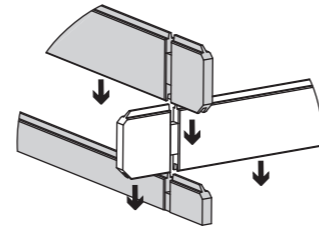

Following the method shown in the illustration, lay the next 6 boards (**No. 2, 3, 5, 6, 7, 8 & 9**) onto the log cabin to create the next level.

**\*Ensure that the boards are level and flush with each other as you lay each one.**



Rubber Mallet

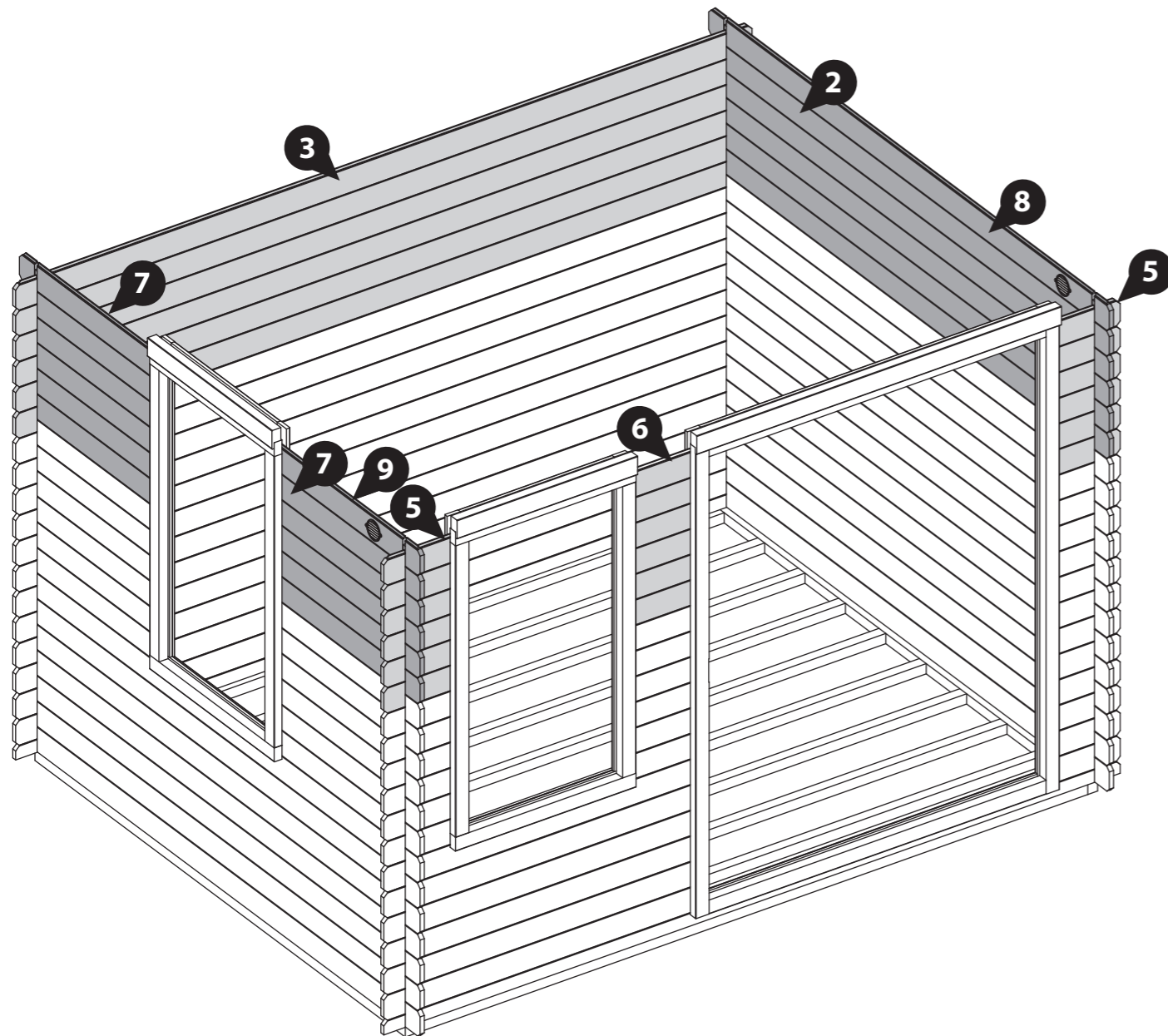

**Step 12**

- Parts Needed - No. 3 QTY 1**  
**No. 10 QTY 1**  
**No. 11 QTY 1**  
**No. 12 QTY 1**

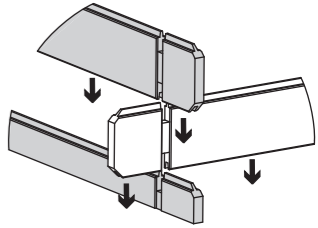

Following the method shown in the illustration, lay the remaining log boards (**No. 3, 10, 11 & 12**) onto the log cabin.

**\*Ensure that the boards are level and flush with each other as you lay each one.**



Rubber Mallet

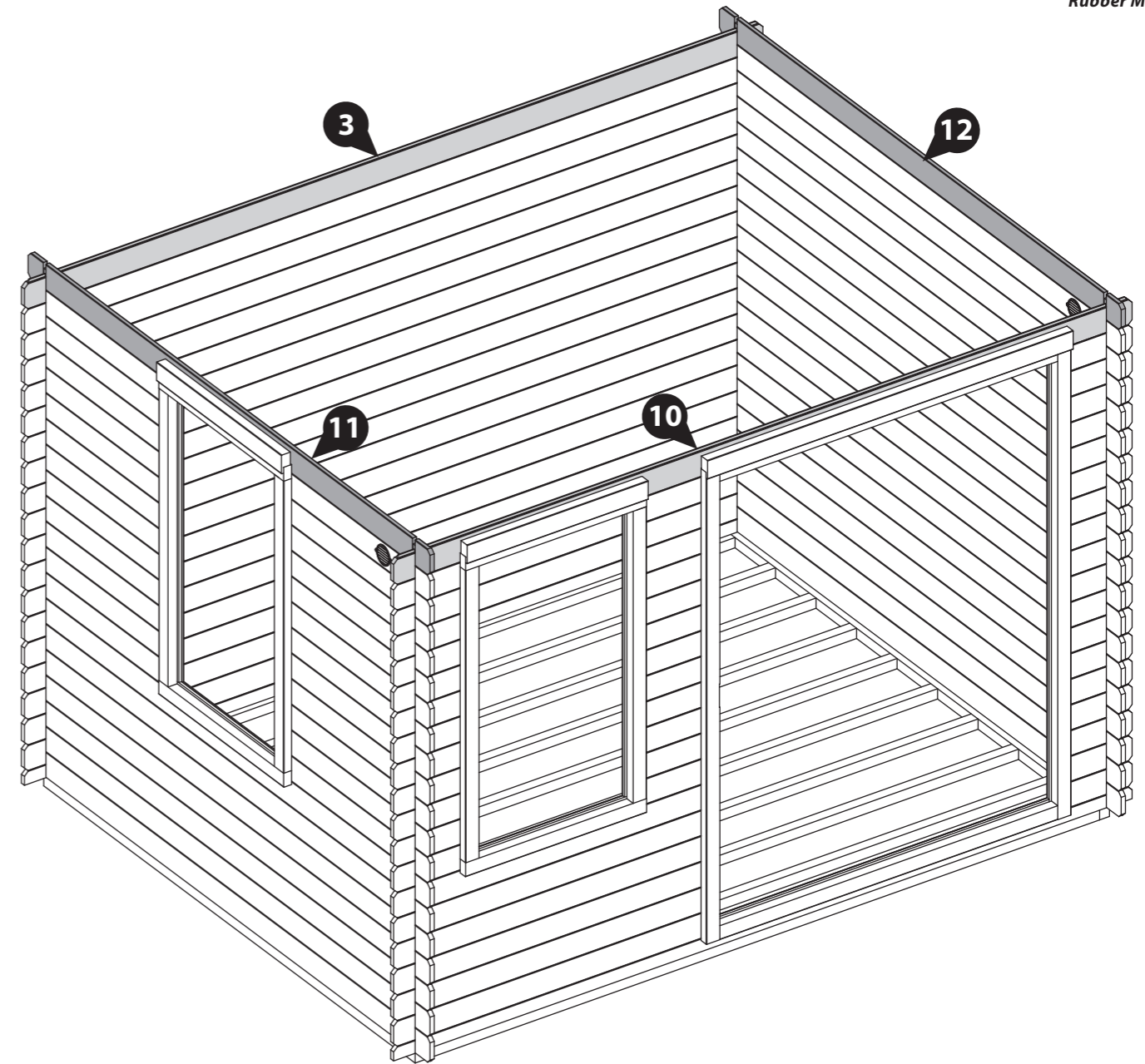

**Step 13**  
**Parts Needed - No. 13 QTY 2**

Following the method shown in the illustration, locate the Gables (No. 13) onto the front and back of the log cabin.

**\*Ensure that the boards are level and flush with each other as you lay each one.**

Fix the gables to the boards below by screwing through the notch using 1x70mm screw per corner, as shown in the illustration

**4x70mm screws**  
**Important: Pre-drill before fixing screws.**

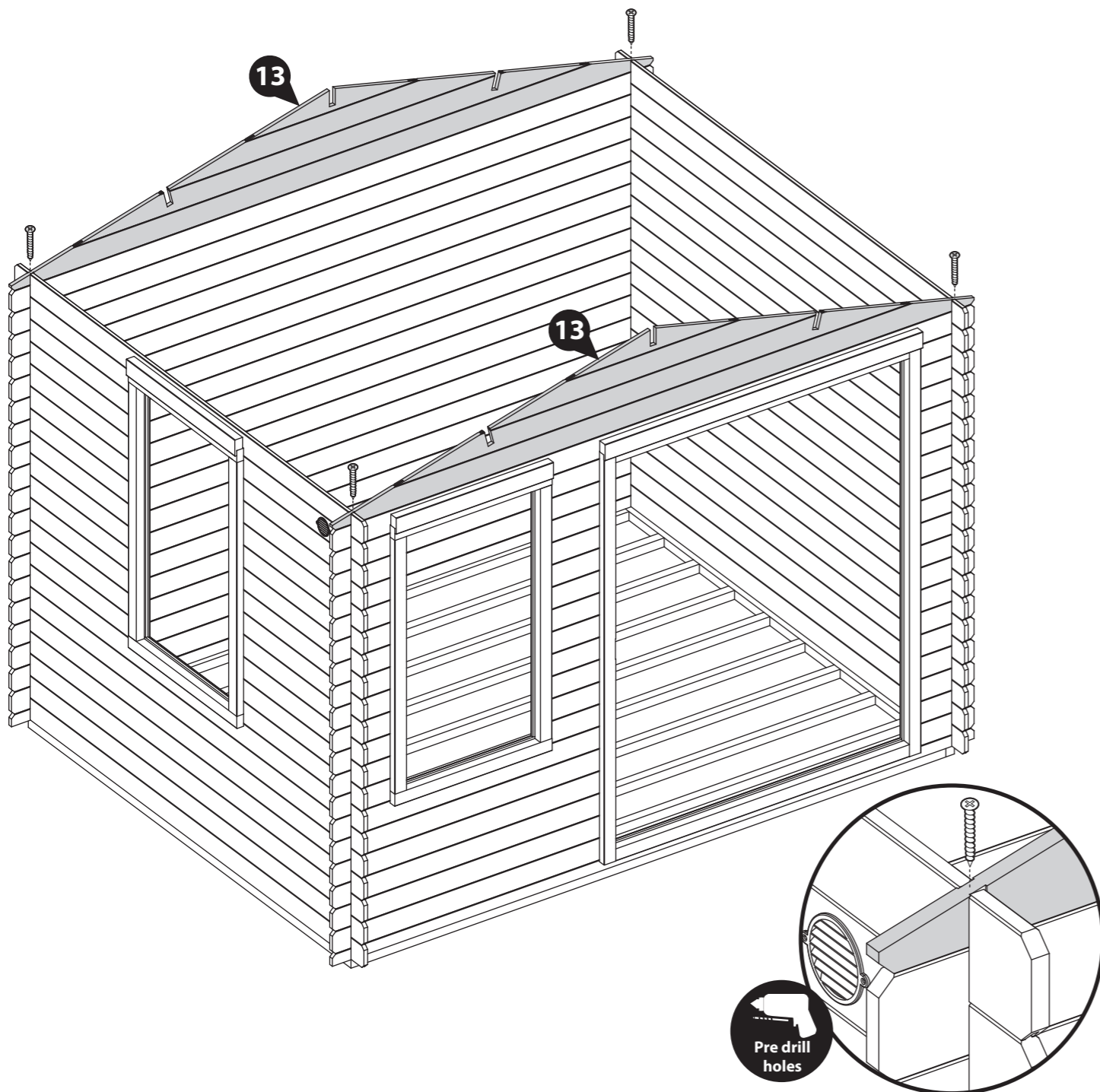
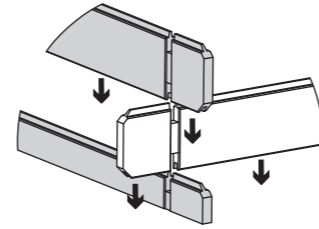

**Step 14**  
**Parts needed - No. 16 QTY 3**

Align the Purlins (No. 16) into the cut out notches on the Gables, ensuring they interlock.

**Note: Use a mallet and a scrap piece of wood to gently fix the purlins into position.**

Secure the roof purlins by screwing through the purlin into the gable (ensure to pre-drill to avoid the boards splitting) using 2x70mm screws per notch.

**12x70mm screws**  
**Important: Pre-drill before fixing screws.**

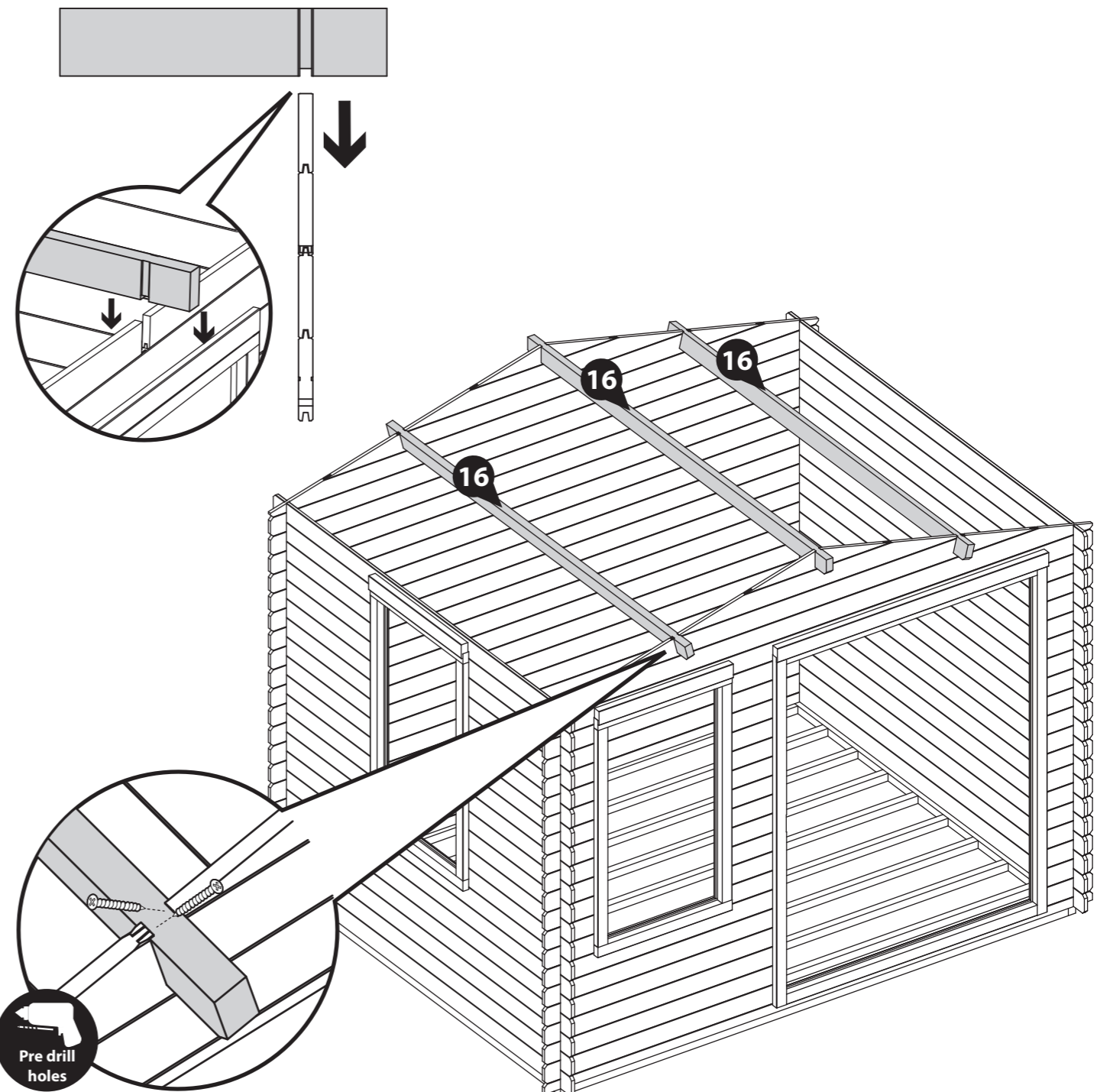

**Step 15**

**Parts needed - No. 17 QTY 50  
No. 25 QTY 5**

- a** Place the first two roof boards (**No. 17**) onto either side of the log cabin, making sure the boards are flush to the end of the roof purlin. Once in position fix to each purlin or log board below using 3x40mm screws per board.

Continue adding the roof boards along the roof, fixing each one into position using 3x40mm screws, making sure that each board is interlocked, flush at the bottom and meets another at the top of the apex. **\*Ensure the roof boards meet at the top of the apex and leave an overhang at the bottom.**

To ensure the roof boards are not laid too close together, use the 2mm spacers (**No. 25**) provided to create a 2mm gap. Adjusting the spacing between the boards allows the wood to swell in damp weather.

You have been issued with 50 roof boards, but you may only need to use 48.

- b** The last board will overhang past the Purlins. Using a straight edge and a pencil, mark out a line as a guide.

Saw along the pencil mark and remove the excess. Place the cut down boards back onto the roof and secure into place using 3x40mm screws per board.

**150x40mm screws**  
**Important: Pre-drill before fixing screws.**

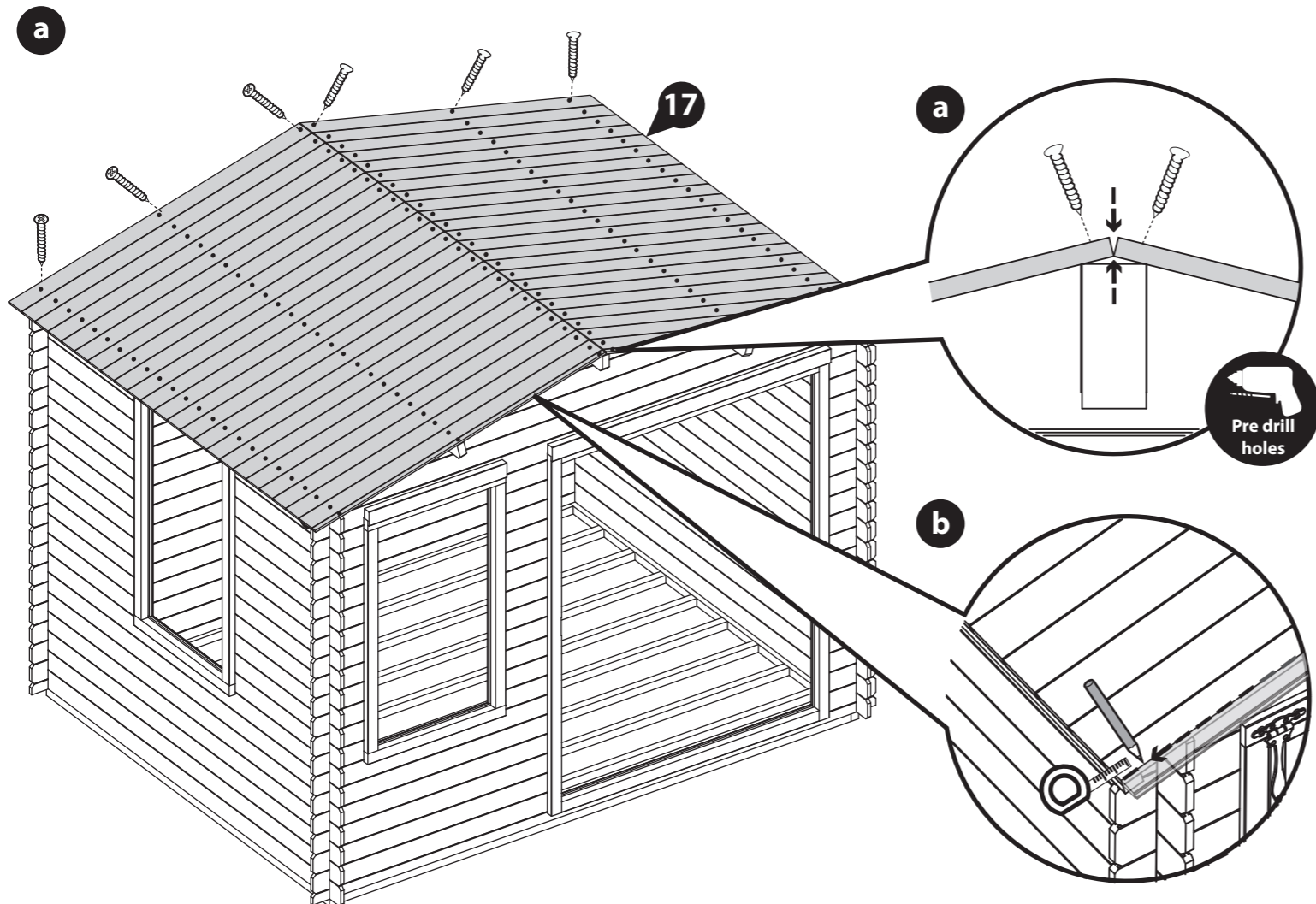

**Step 16**

**Parts Needed - No. 19 QTY 2**

Ensuring the roof boards are flush and level, locate the Eaves Frames (**No. 19**) to the underside of the roof boards on either side of the log cabin. Secure in place using 7x30mm screws per frame, as shown in the illustration.

**14x30mm screws**  
**Important: Pre-drill before fixing screws.**

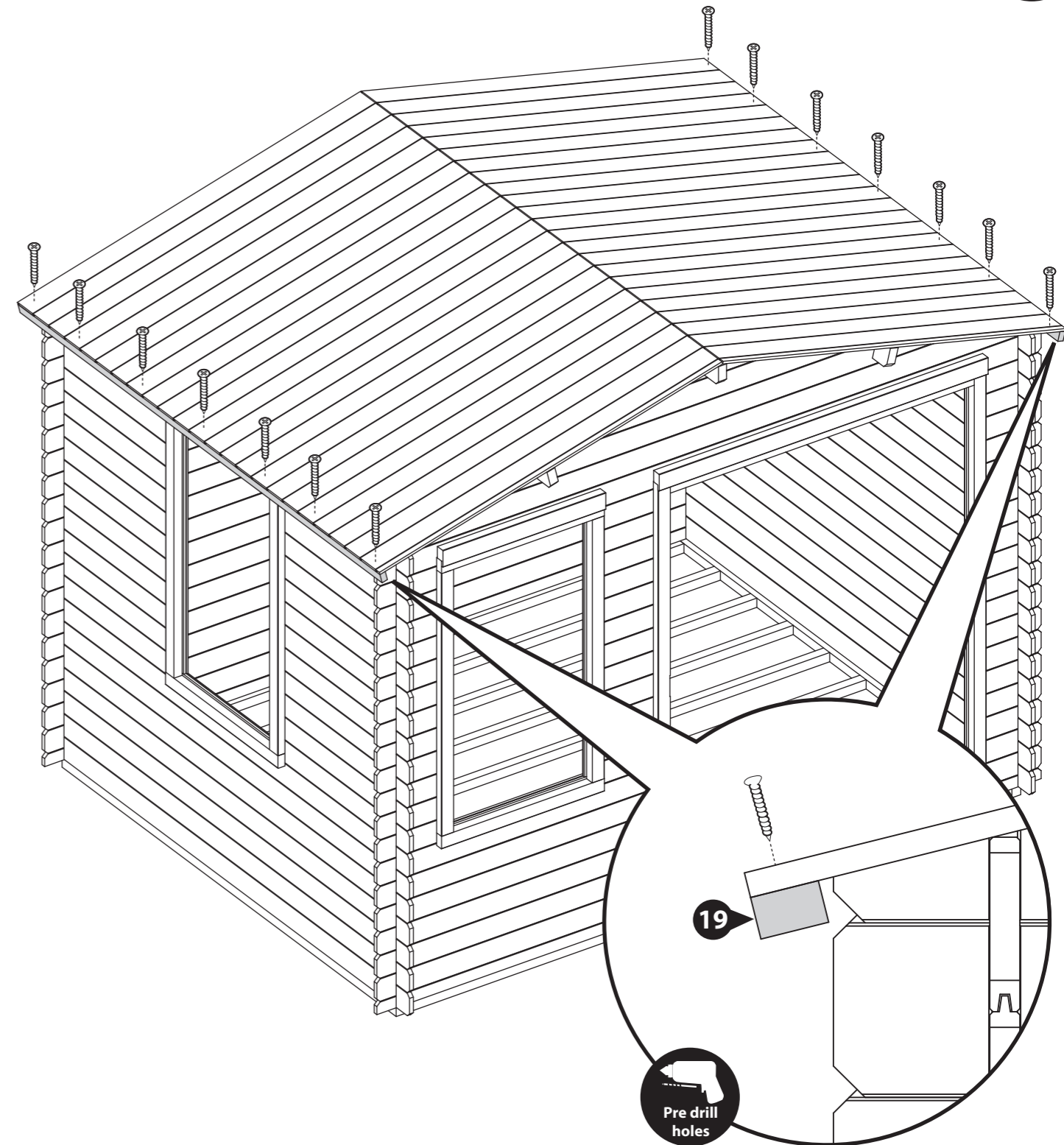
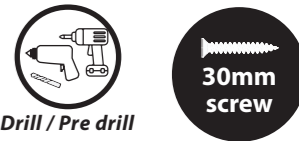

**Step 17**

**Parts Needed - No. 39 QTY 2  
No. 45 QTY4**

- a** Place the Window (**No. 39**) onto a flat surface and fix 2 x T-hinges (**No. 45**) to the window using 3x30mm black screws per hinge.
- b** Locate the Window into the Window Frame on the cabin, ensuring there is equal spacing on each side between the window and window frame.

Secure into position by screwing through the T-hinges (**No. 45**) using 4x30mm black screws per hinge, making sure the windows open and close freely without restriction.

**\*Ensure to screw into the framing and not into the channel.**

Use this method to assemble two windows.

**28x30mm black screws**  
**Important:** Pre-drill before fixing screws.

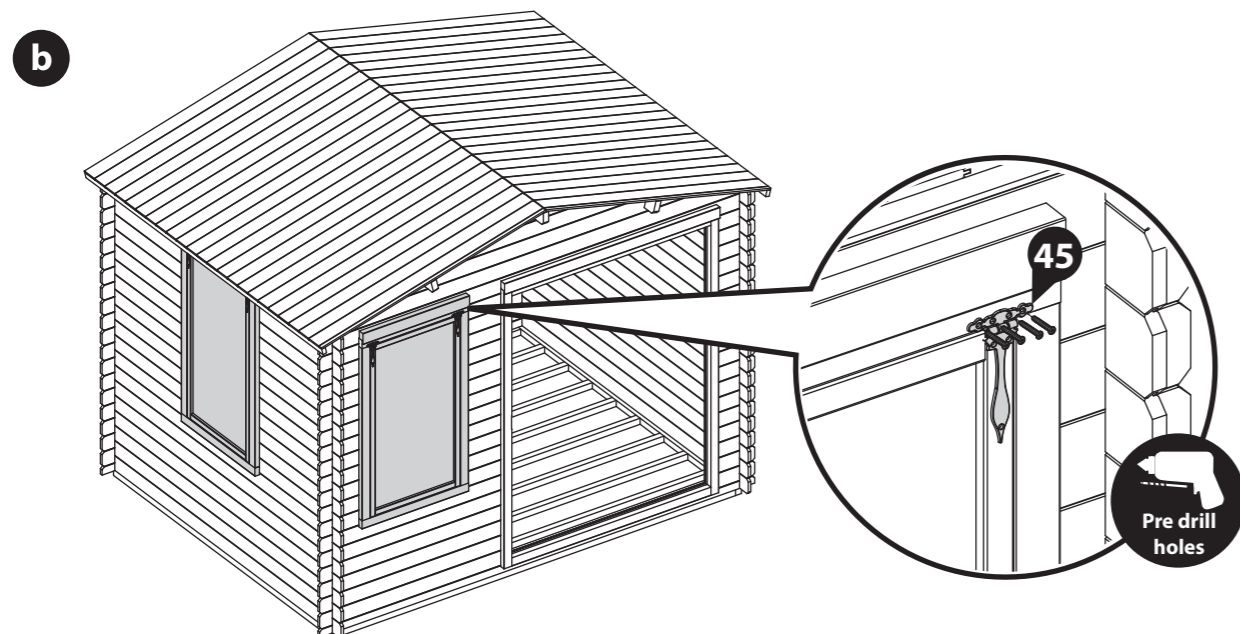
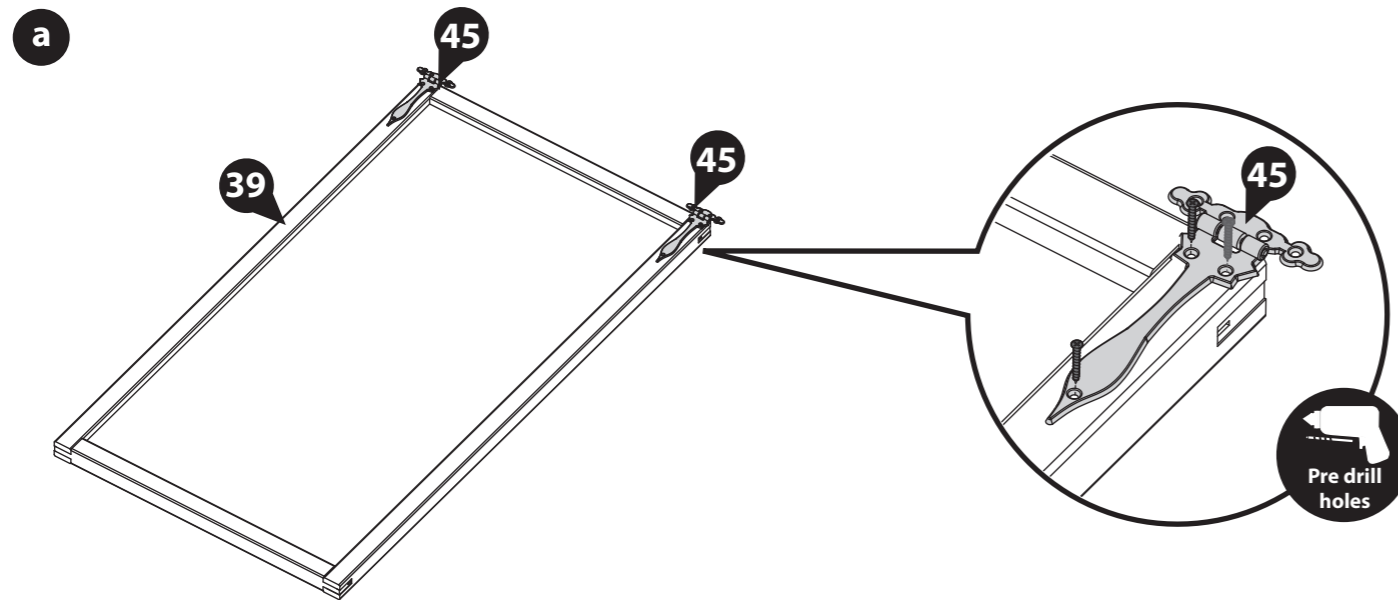
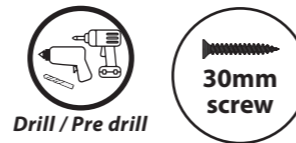

**Step 18**

**Parts Needed - No. 46 QTY 2**

On the inside of the log cabin, fix the casement stay (**No. 46**) onto the window (**No. 39**) and the casement stay pins to the window framing using 6x30mm black screws.

**\*Ensure the casement stay is centralised on the window.**

Use this method to fit one casement stay to each window.

**12x30mm black screws**  
**Important:** Pre-drill before fixing screws.

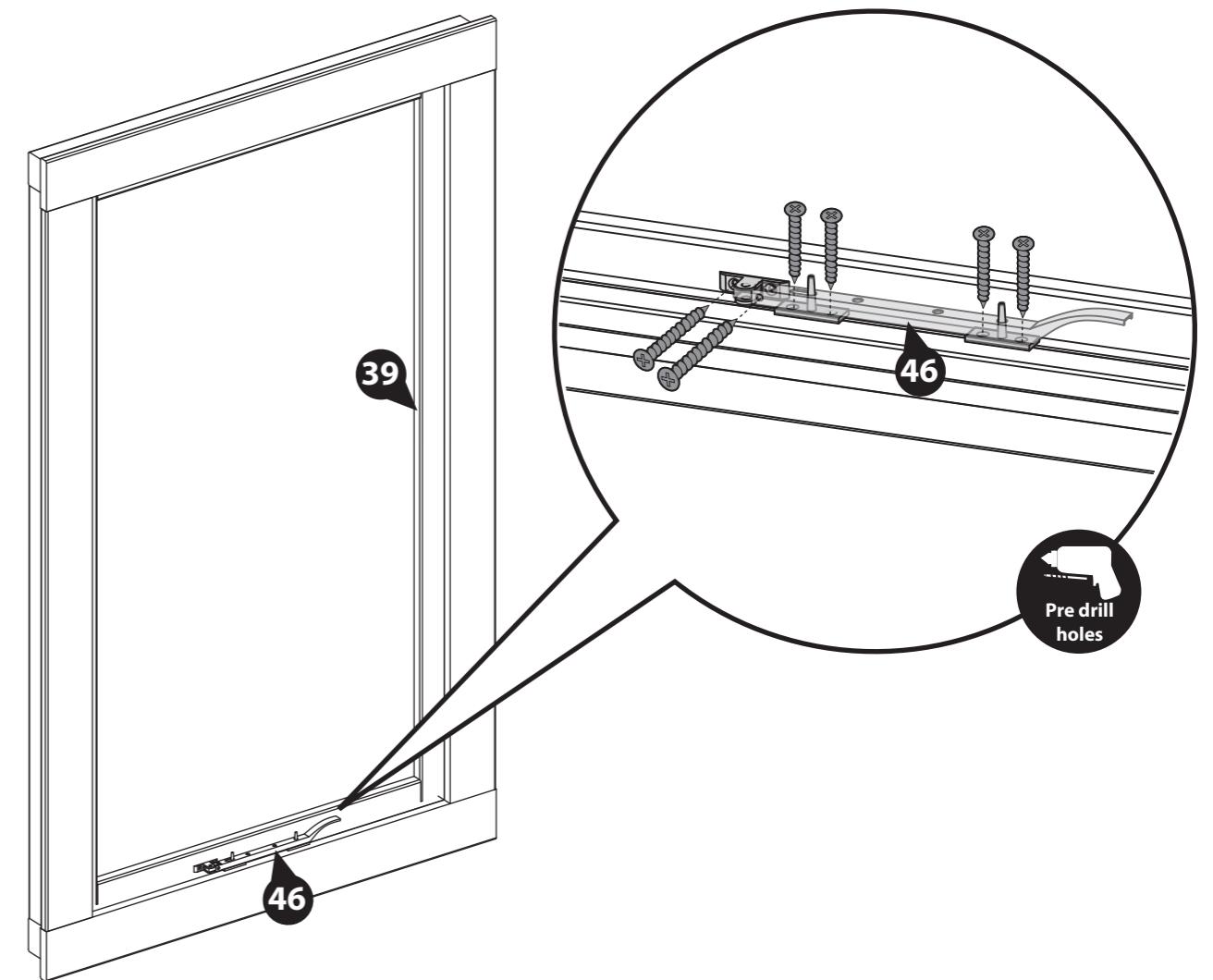
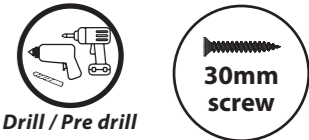

**Step 19**

**Parts Needed - No. 26 QTY 1**  
**No. 27 QTY 1**  
**No. 34 QTY 6**

- a** Once the roof is fixed, place the master and secondary doors (**No. 26 & 27**) onto a flat surface and fix 3 x 9 inch T-hinges (**No. 34**) to each door using 5x30mm black screws per hinge.
- b** Locate the doors into the door frame on the cabin, ensuring there is equal spacing on each side between the doors and door frame.

Secure into position by screwing through the T-hinges (**No.34**) using 4x30mm black screws per hinge, making sure the doors open & close freely without restriction.

*\*Ensure to screw into the framing and not into the channel.*

**54x30mm black screws**  
**Important: Pre-drill before fixing screws.**

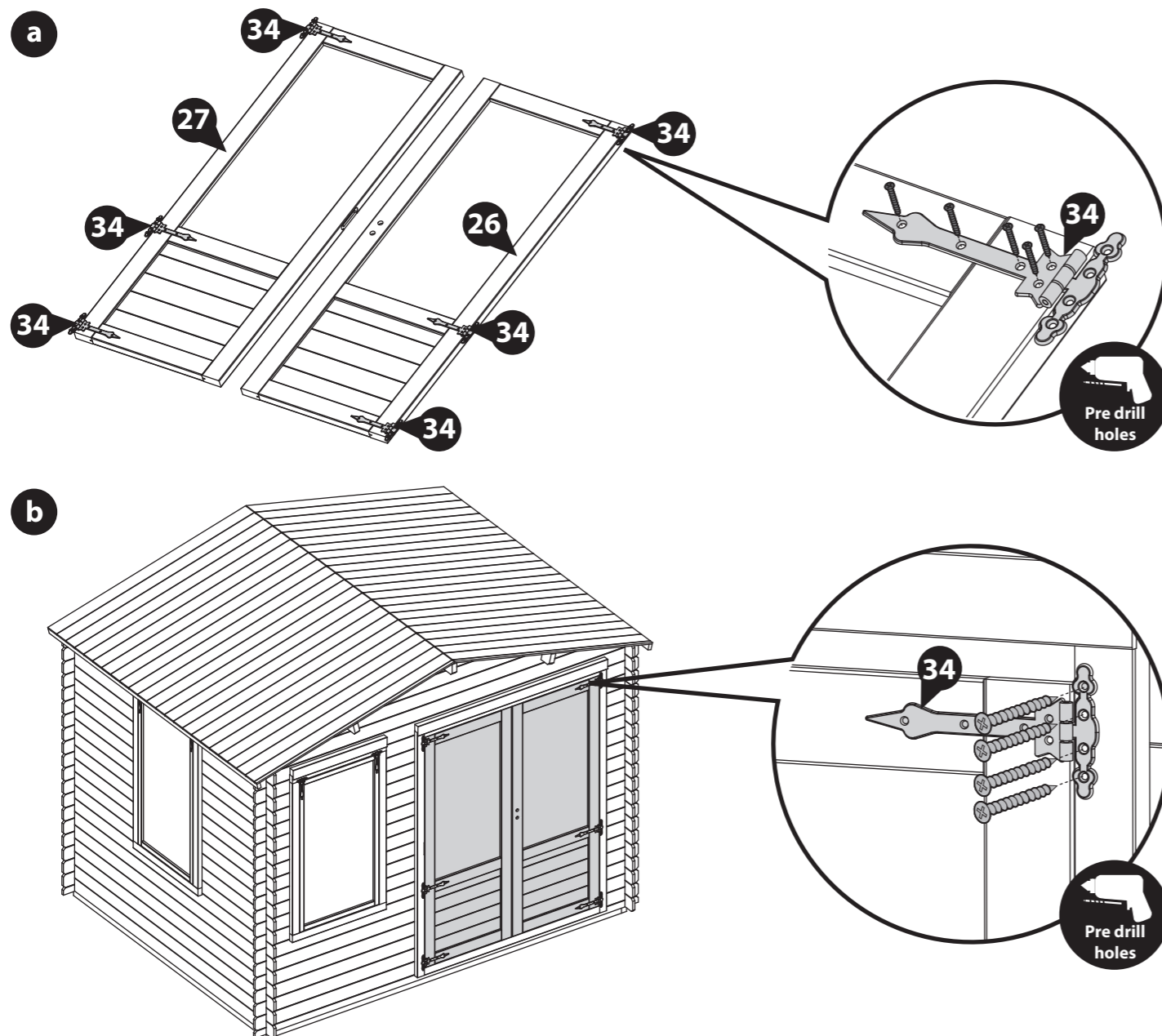
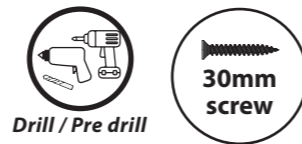

**Step 20**

**Parts Needed - No. 35 QTY 1**  
**No. 36 QTY 1**  
**No. 37 QTY 1**

- a** Fit the Mortice Lock (**No. 36**) into the recess in the master door (**No. 26**) and secure using the screws provided. Attach the Key Plate (**No. 37**) to the secondary door (**No. 27**) with 4x30mm screws.
- b** Locate the Door Handles (**No. 35**) either side of the master door and connect with the metal bar. Fix to the door using 8x30mm black screws. Ensure the lock mechanism closes and locks correctly. If not, remove the lock and turn the catch around using the small grub screw.

**8x30mm black screws**  
**4x30mm screws**  
**Important: Pre-drill before fixing screws.**

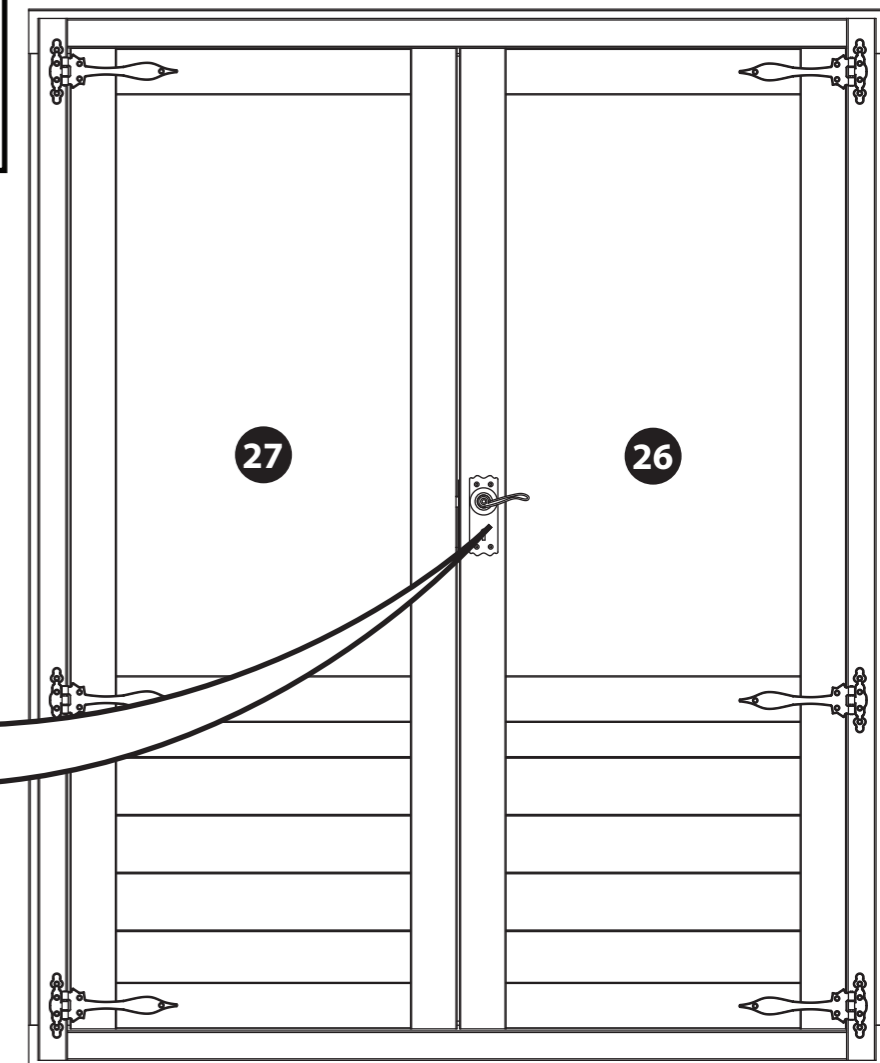
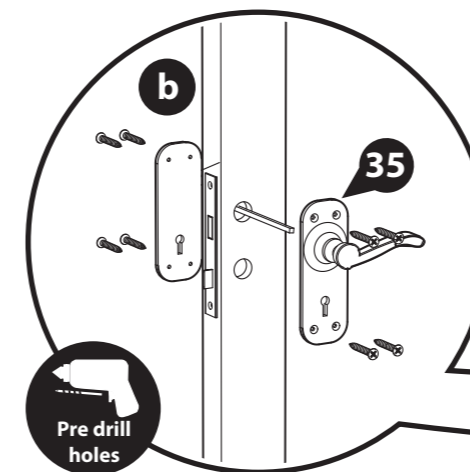
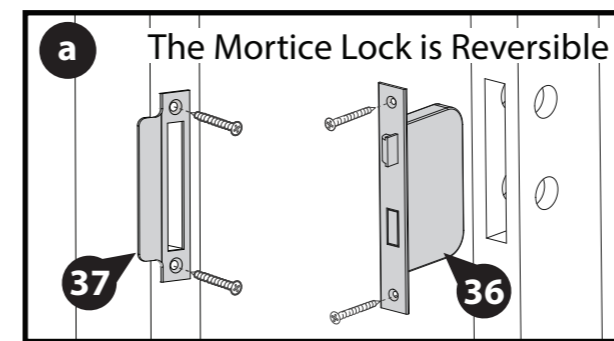
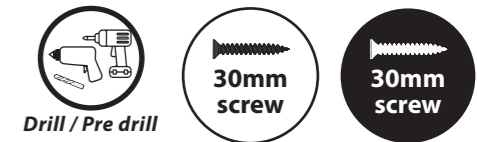



**Step 21**

**Parts Needed - No. 32 QTY 1  
No. 38 QTY 2**

- a** Attach the Door Strip (**No. 32**) to the back of the secondary door using 4x40mm screws as shown.

Once fixed, place the Tower Bolts (**No. 38**) roughly into position at the top and bottom of the door strip. With a pencil mark around the bolt.

- b** After marking the bolt onto the frame, drill a hole for the barrel bolt to locate into.

- c** Following the hole being drilled, place the tower bolts into position and secure using 4x40mm screws per bolt.

**12x40mm screws**

**Important:** Pre-drill before fixing screws.



Drill / Pre drill

**40mm screw**

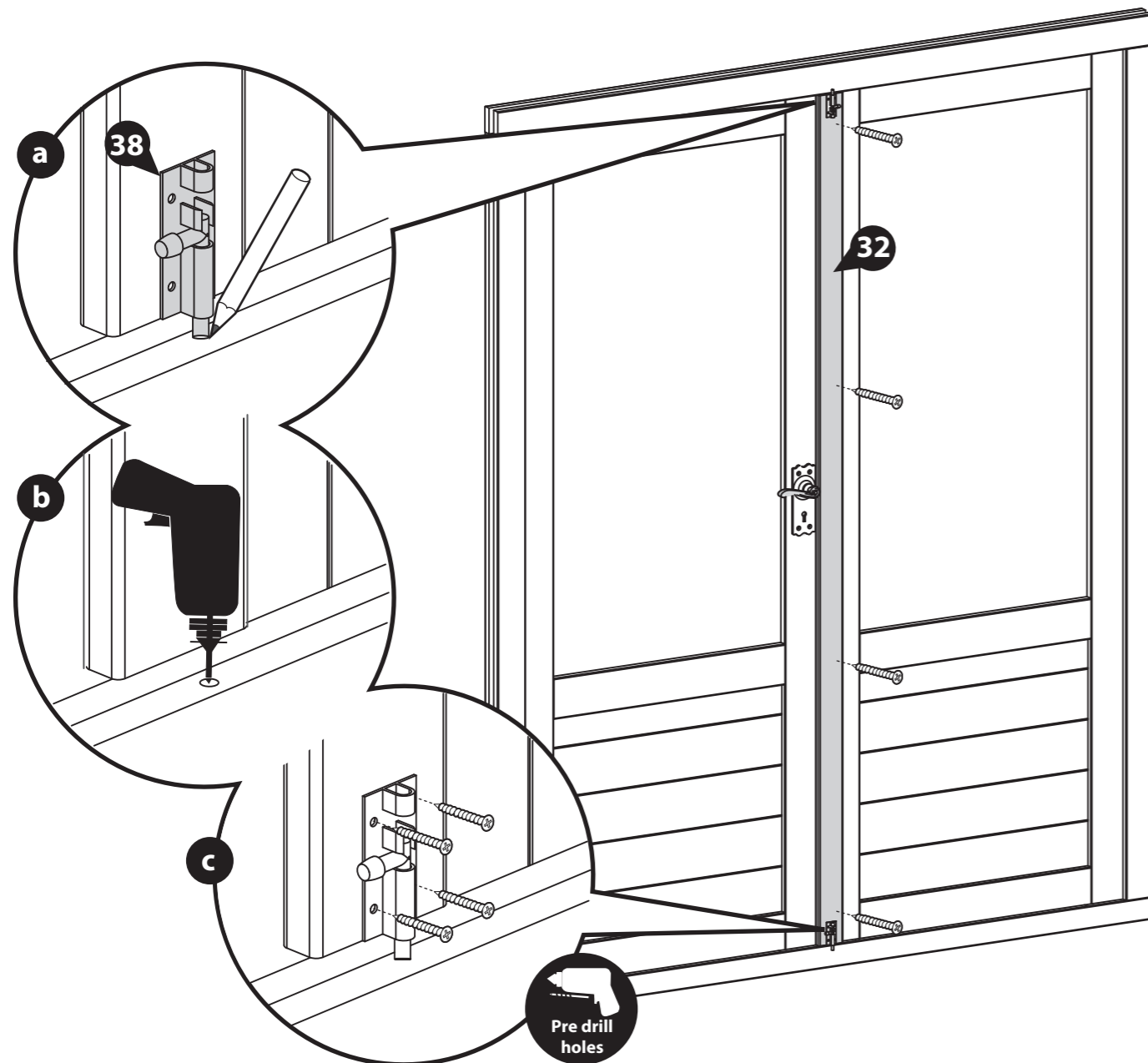

**Step 22**

**Parts Needed - No. 18 QTY 29**

- a** Place the first floor board (**No. 18**) inside the building flush to the log board on one side. Continue adding the floor boards (*internally*) making sure to interlock each individual board.

You have been issued with 29 floor boards, but in reality you may only need to use 28.

**\*Do NOT secure the boards until the last board has been measured and cut.**

- b** Once a full board can no longer fit, measure the gap between the bottom of the tongue (*on the last board placed*) and the log board. Ensure to measure at multiple points along the board for added accuracy.

Using a straight edge, mark out the measurement onto the last floor board (**No. 18**), saw along the length and remove the excess. *Mark the final board 2mm under the measurement; This will allow the timber to expand and contract correctly.*

Once all the floor boards are in position, secure each board in place using 8x40mm screws per board.

**\*\*\*Please Note:** Ensure to screw through each of the floor boards into the floor bearers.

**232x40mm screws**

**Important:** Pre-drill before fixing screws.



Saw



Drill / Pre drill

**40mm screw**

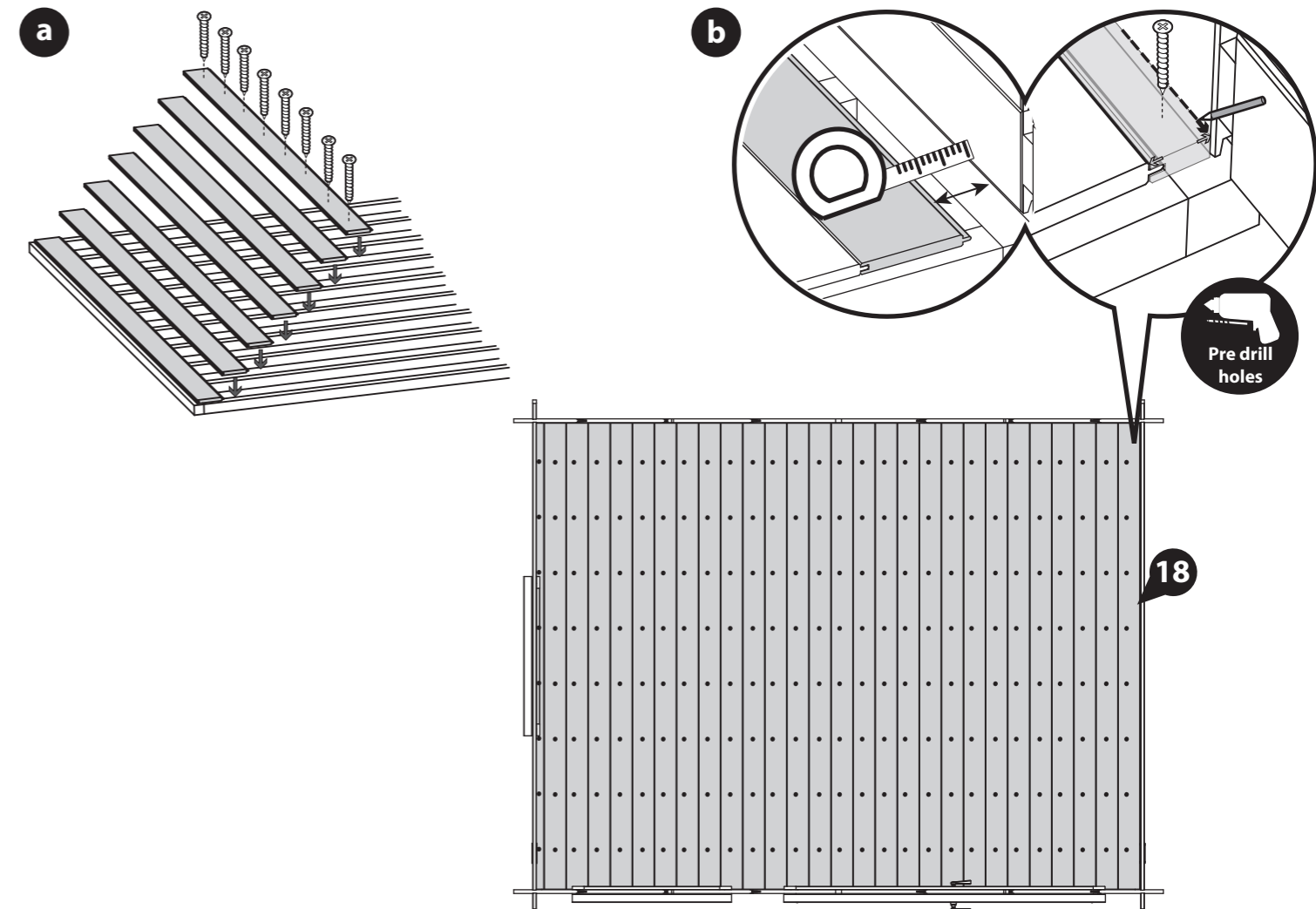

**Step 23**

**Parts needed - No. 21 QTY 5**

Inside the building place the closure trim (**No. 21**) against the boarding and align with the roof as shown in the illustration.

**\*Measure and cut the closure trims to fit the internal space.**

Once in position fix each trim into place by pre drilling a pilot hole and using 6x30mm screws per trim, equally spacing them along the face of the board.

**30x30mm screws**

**Important:** Pre-drill before fixing screws.

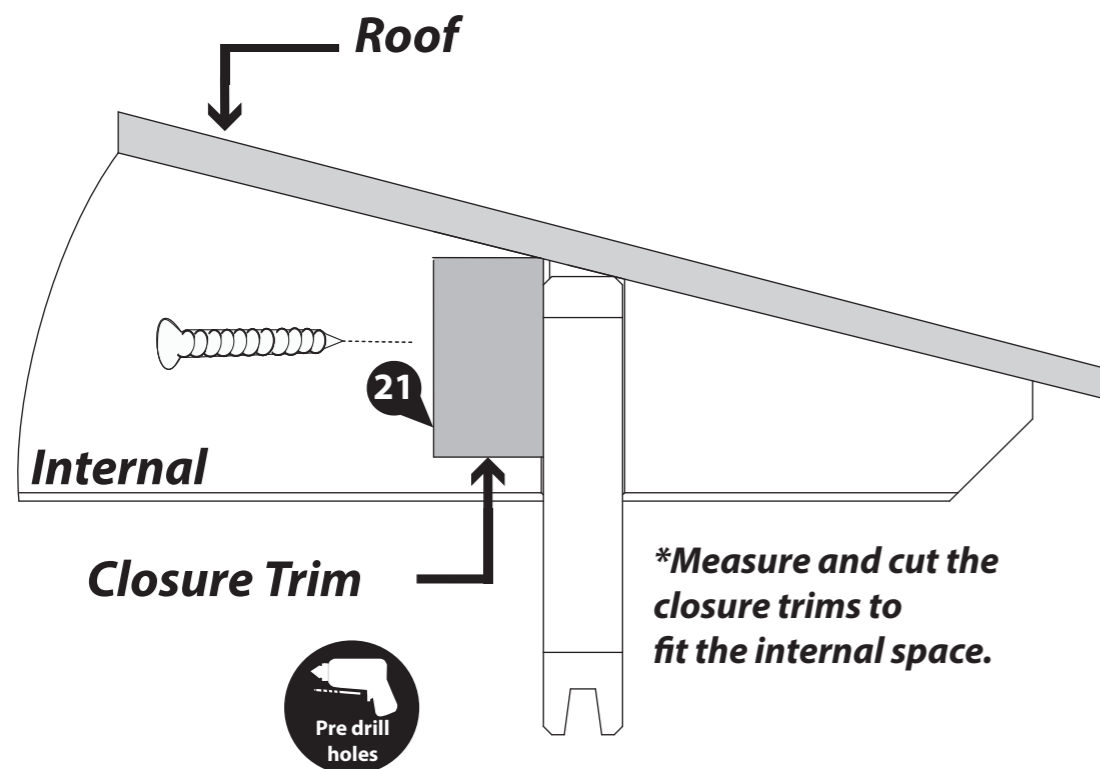

**Step 24**

**Parts needed - No. 21 QTY 5**

Once the floor has been laid, arrange the closure trim (**No. 21**) around the outside edge of the floor (**internally**), measure and cut down accordingly to best match the internal space.

Secure each trim section into place using 6x30mm spaced equally along the board as shown in the illustration.

**\*Do NOT fix the closure trim to the floor boards.**

**30x30mm screws**

**Important:** Pre-drill before fixing screws.

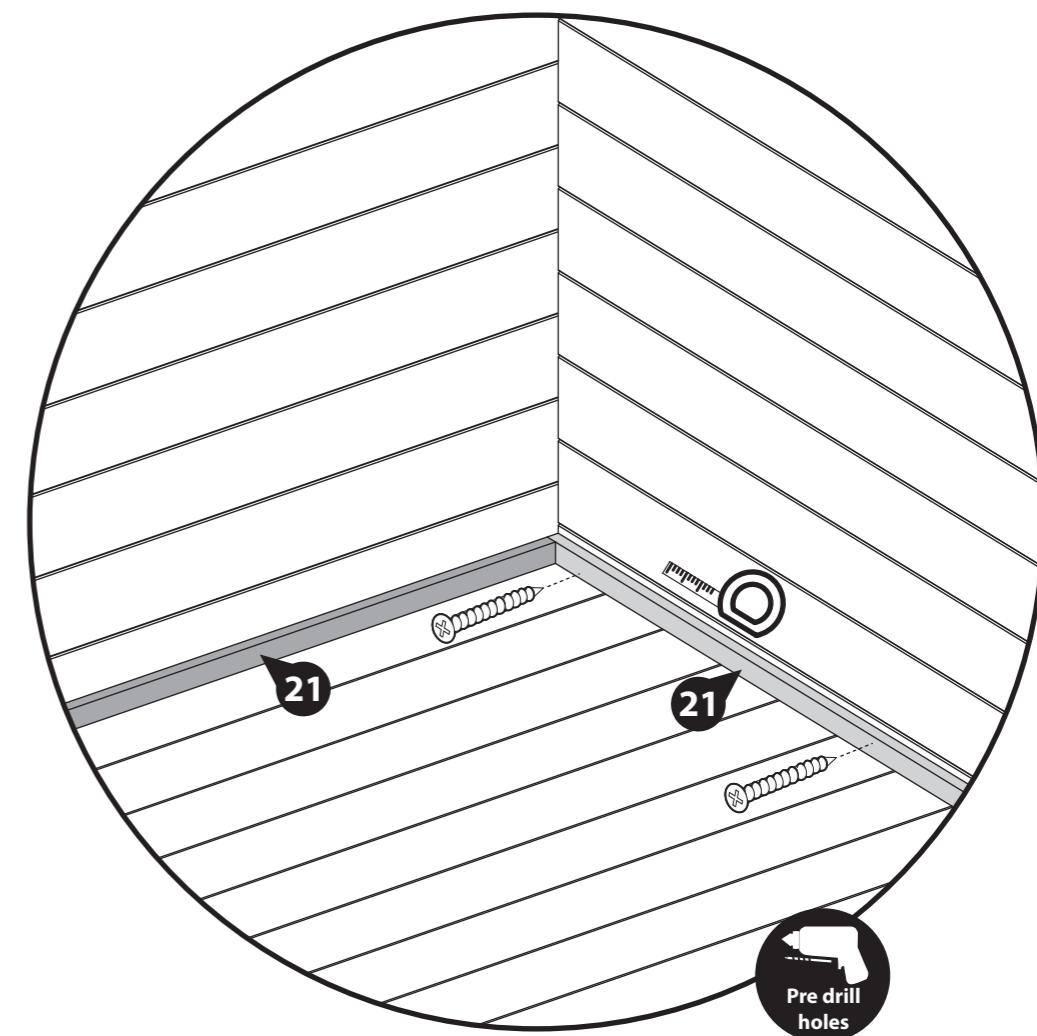

**Step 25**

**Parts needed - No. 24**

Cut the felt (No. 24) into four strips measuring **2700mm (L) X 1000mm (W)**.

Lay the sheets onto the roof in the order shown in the illustration, ensuring each sheet overlaps by 100mm.

**\*Ensure there is approximately 50mm of overhanging felt around each.**

Once the felt is laid out, fix to the roof using felt tacks at 100mm intervals.

**200 x Felt Tacks**



Cutting tool



Felt tacks

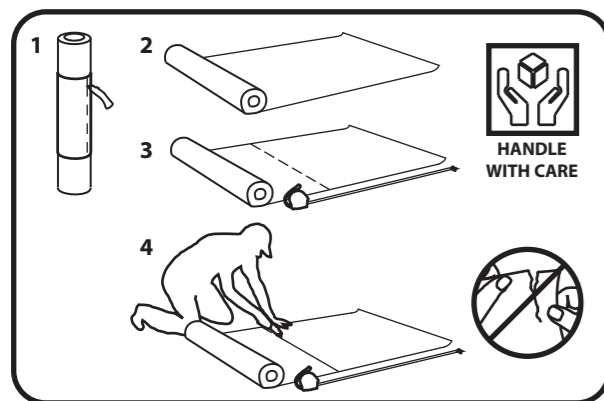
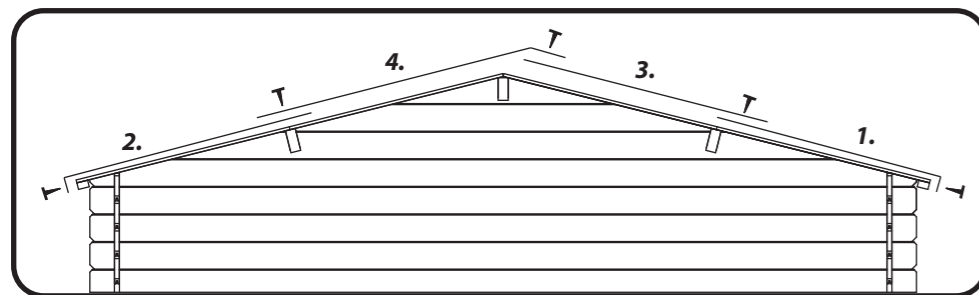
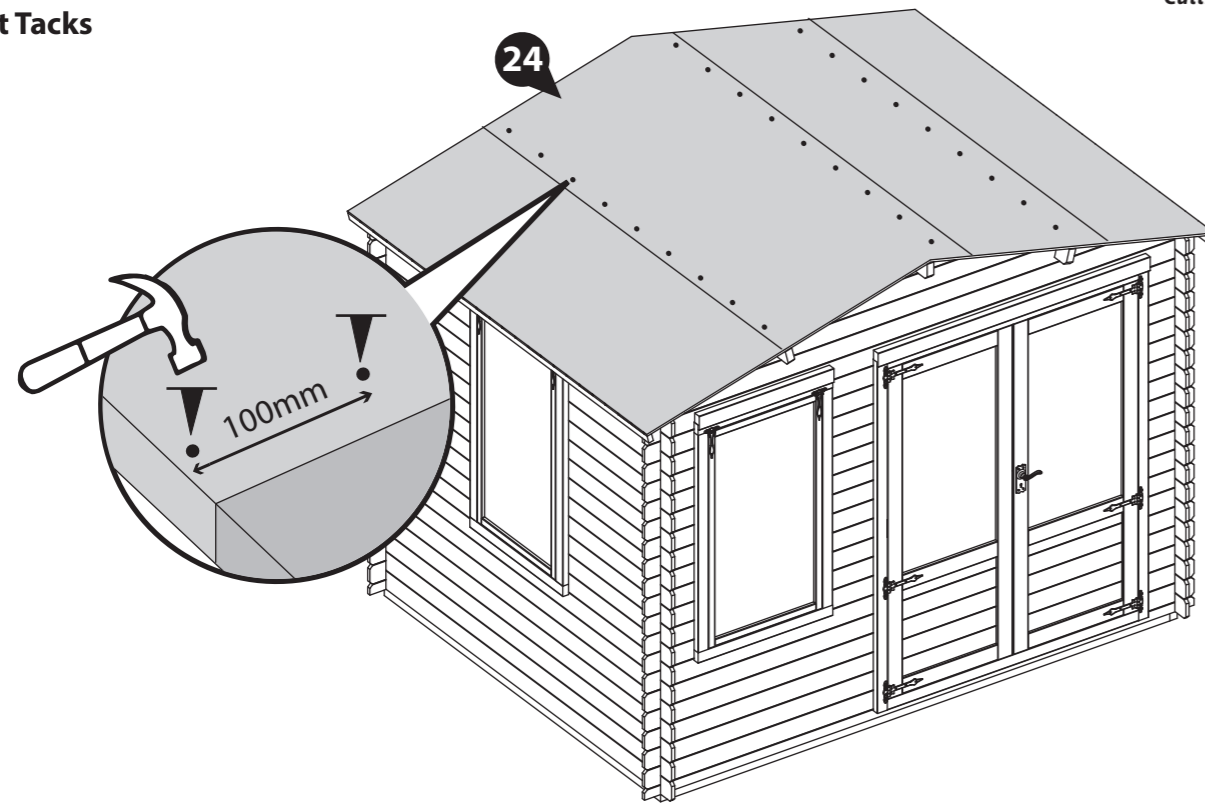

HANDLE WITH CARE

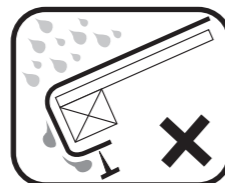

**Step 26**

**Parts Needed - No. 33 QTY 1  
No. 44 QTY 2**

Attach the Rain Guards (No. 44) to the Window frames, fixing in place onto the framing above the windows using 3x70mm screws per guard.

Attach the Rain Guard (No. 33) to the Door frame, fixing in place onto the framing above the Door using 4x70mm screws.

**10x70mm screws**

**Important: Pre-drill before fixing screws.**



Drill / Pre drill



70mm screw

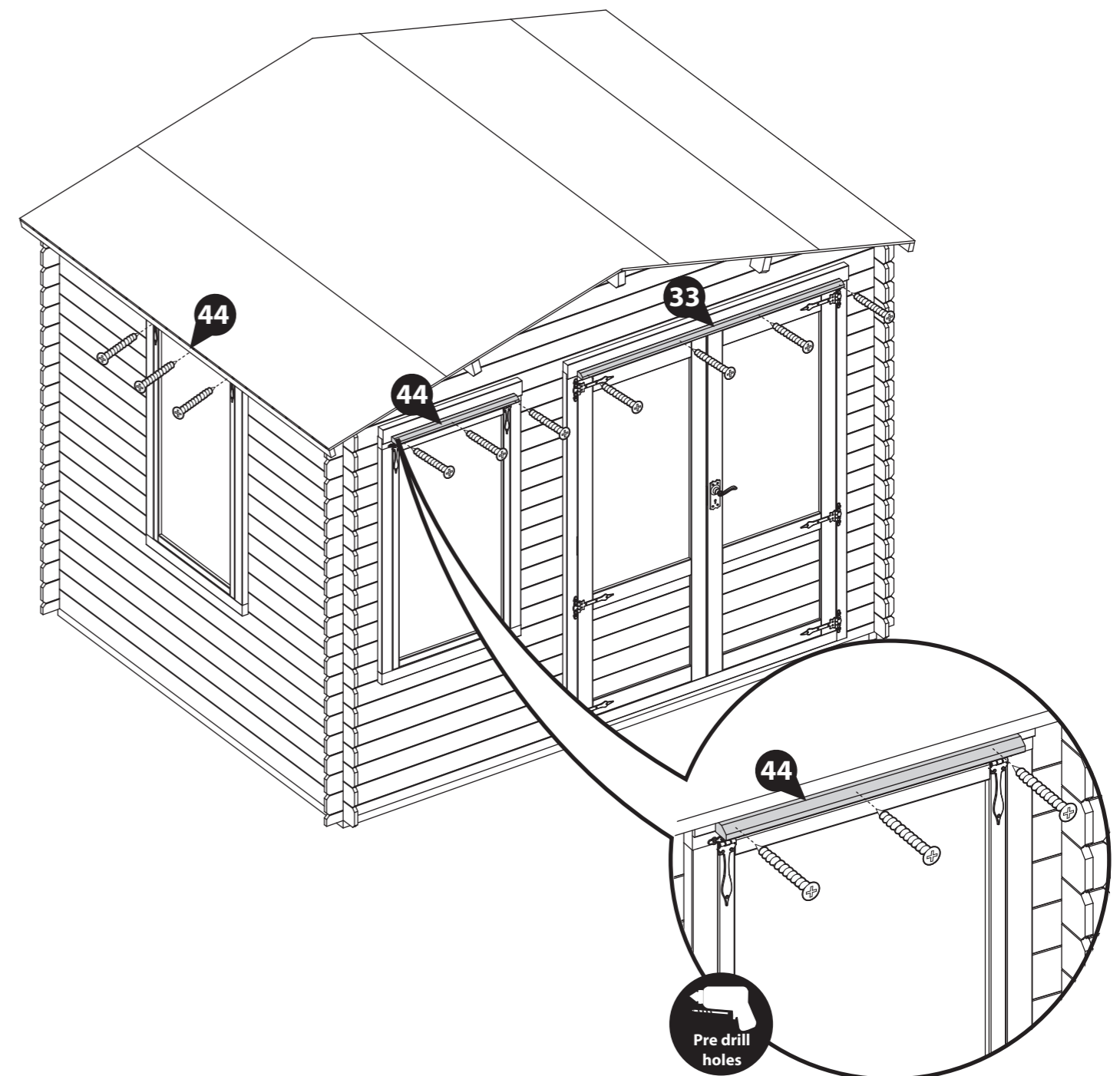

Pre drill holes

### Step 27

Parts Needed - No. 20 QTY 4

Locate the Fascias (No. 20) to the front and back of the log cabin (ensuring to trap the felt in between the Fascias) and secure in place using 3x40mm screws per Fascia, screwing through the Fascia in to the Purlin, log board or eaves frame behind.

Ensure the angled cuts meet at the top of the apex.

12x40mm screws

Important: Pre-drill before fixing screws.

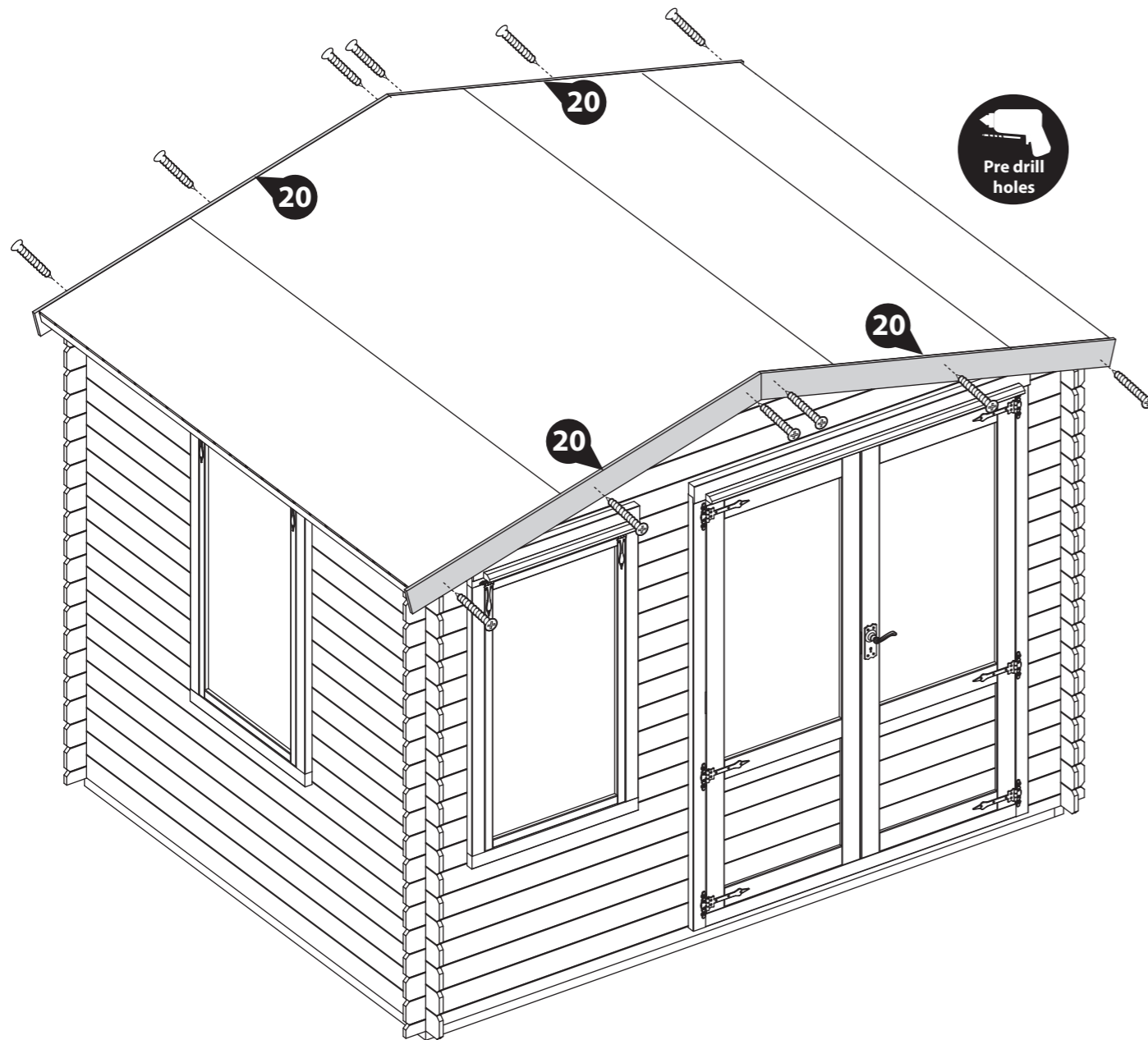

### Step 28

Parts needed - No. 22 QTY 8

Arrange the storm braces (No. 22) around the building (internally), placing two storm braces per wall.

\*Ensure the storm braces are secured at the highest point possible on each side.

Fix in place using 2x60mm bolts per brace, making sure the washer & nut are tightened from the outside of the building.

The storm braces will need to be altered during the buildings life as the moisture content within the log boards changes. The boards will expand during periods of high moisture (Winter) and shrink during periods of low moisture (Summer).

\*\*Storm braces are required to be adjusted during changes in humidity to allow the building to expand and contract. To do this, periodically loosen the bolts, adjust the storm brace position and re-tighten.

\*\*\*Important: Ensure each bolt is tightened using a washer so as not to damage the log boards.

16x60mm bolt sets

Important: Pre-drill before fixing screws.

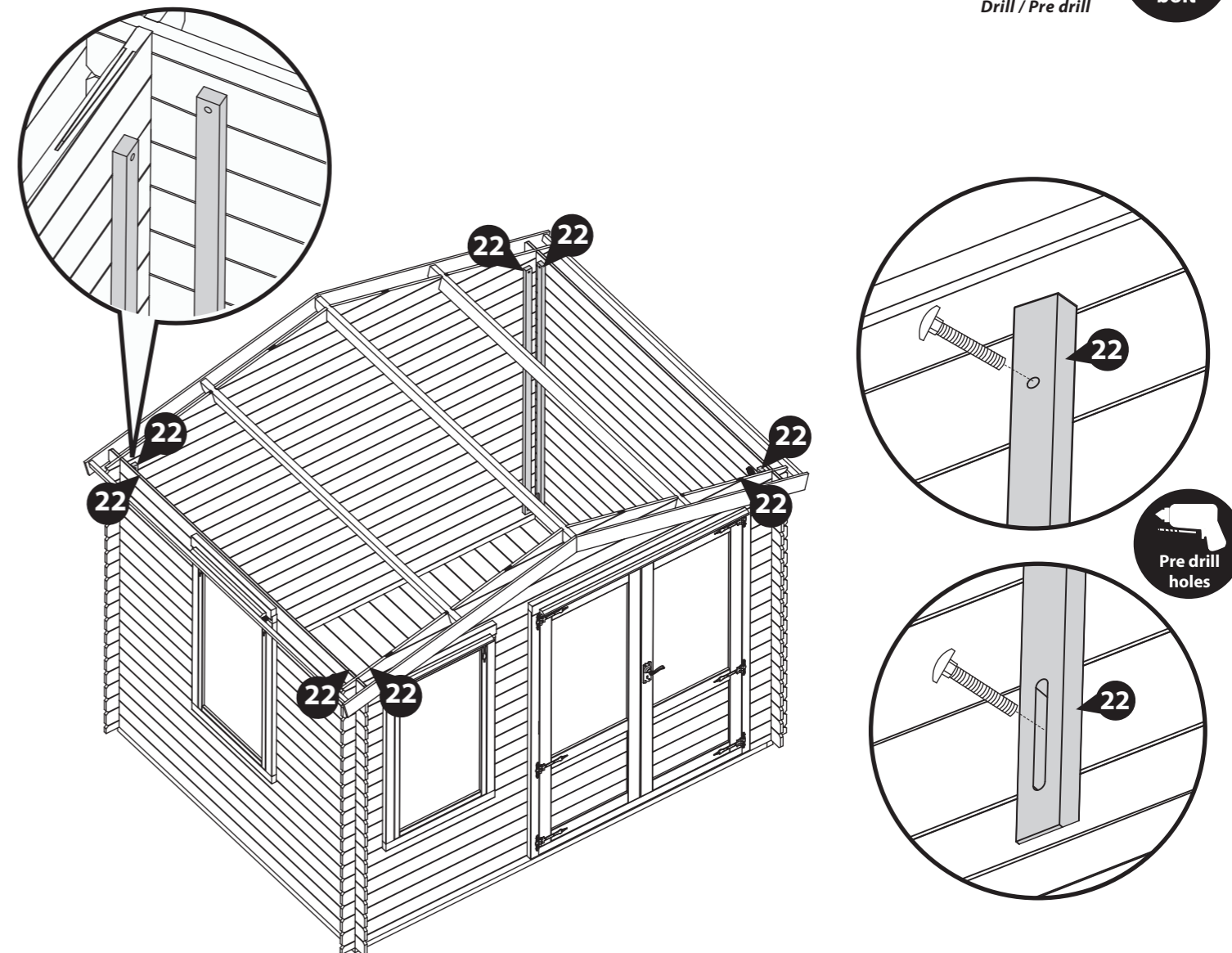
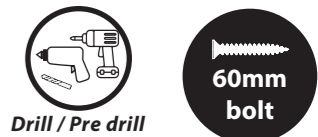

**Step 29**

Once constructed, apply a preserving treatment and a waterproofing treatment to your garden building as soon as possible. This will help to protect your building and prevent decay.

See page 22 for a full guide and instructions.

Once fully treated, score around the protective covers on the glazing and carefully peel the coverings back. It is essential to seal around all window framing with silicone sealant (not provided) to minimise water ingress.

**\*Please Note:** This image is for illustrative purposes and may differ from your window and door position. Nevertheless, the process of treating your building, removing the protective covers and sealing the windows is the same.

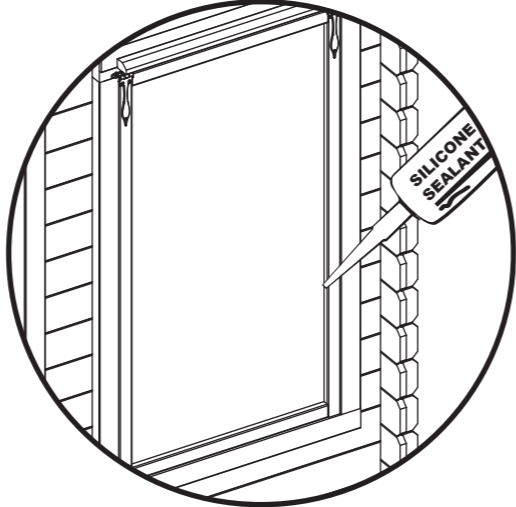
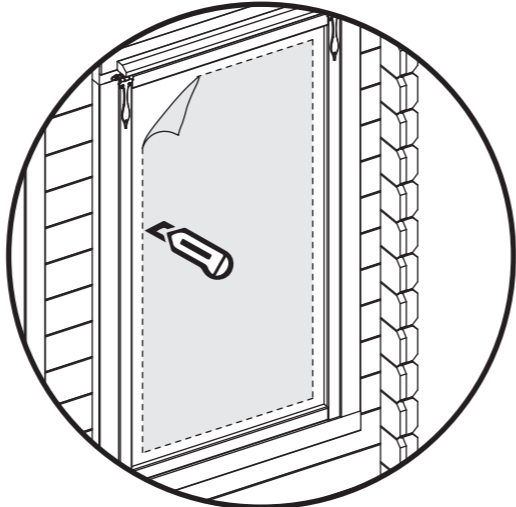
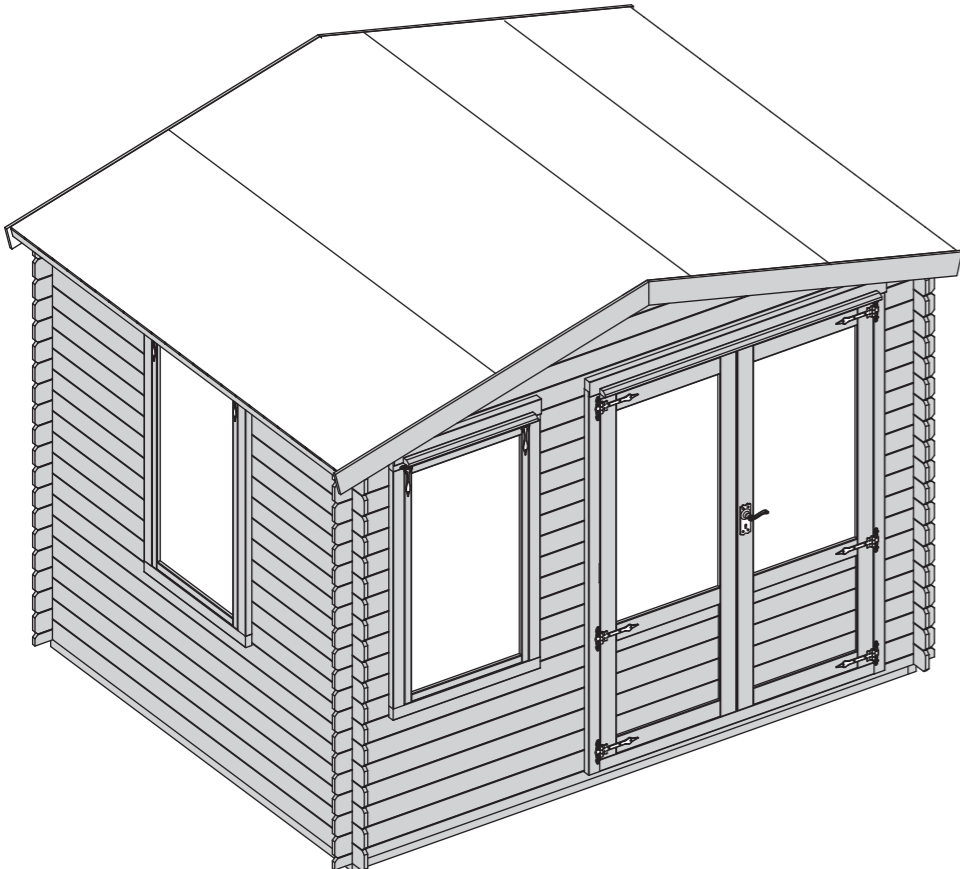



**LEAVE US A REVIEW...**

Want to share your experience with us?  
Leave us a review on Feefo, TrustPilot or Google.

Your reviews help other people find and trust our business, as well as helping to play an important role in our growth and improvement!

## TREATING YOUR GARDEN BUILDING

Preservation of wood that's outdoors is vital. A little early care will help protect your garden building, improve its appearance and ensure maximum longevity. Insects, moisture, salt, and changing weather can have dramatic effects on the stability and appearance of your garden building. Once your building is installed, you've checked it over and you're happy with it, you can take a few basic precautions to prepare it for the elements. Treating your garden building helps prevent decay and, by repelling water, discourages the growth of moulds and fungi that could jeopardise the structural integrity of the wood.

**Dip Treated buildings** - Require a preservative treatment to protect against rot and decay and a waterproof treatment to prevent water ingress  
**Pressure Treated buildings** - Require a waterproof treatment to prevent water ingress  
**Log Cabins/Insulated Garden Rooms** - Are supplied untreated and require a preservative and waterproofing treatment.



**ANY QUESTIONS?**  
Scan the QR code to contact us via our customer portal.

To apply a preservative and water proofing treatment (pressure treated products do not require a preserver), follow the manufacturer's instructions but in principle, stick to the following steps:

- ✓ Weather permitting, ensure to treat your garden building within 14 days of installation.
- ✓ Wear latex or rubber gloves, eye protection and (if spraying) a mask.
- ✓ Prepare the wood, by sanding down any ridges or inconsistencies in the wood, smoothing out knots and end-cuts.
- ✓ Choose a dry day to treat your garden building. If you're spraying rather than brushing paint on, avoid a windy day.
- ✓ Be sure you can safely reach all the sections you need to paint - and if you need a ladder, make sure it's safely positioned before climbing. Lay dust sheets around to avoid paint splatters on your base or surrounding plants.

- ✓ Tape around windowpanes to avoid smears when you're painting the frames.
- ✓ Keep pets and small children out of the way. The last thing you want is to have fur on your garden building paint, or little painted footprints all over your garden and home.
- ✓ Fill any gaps in the building's body with caulk or wood filler to prevent water and draughts getting in. Silicone based caulk is flexible and will move with the timber when temperature and humidity change. Allow to dry completely before treating. A handy tip for finding gaps is to go into your garden building and look for light leaking through joins and frames. If light gets in, then so will water.
- ✓ Liberally apply at least two coats of the treatment products with a brush or spray, taking care to allow the first coat to completely dry before applying the second.
- ✓ Make sure the solution permeates the whole of the surface area, especially around natural cracks, end cuts and nail/screw holes.



APPLY WOOD TREATMENT  
**IMMEDIATELY**  
AFTER ASSEMBLY



## 1 Perimeter

Check around the perimeter of your product to ensure there are not trees or plants that are in contact with or overhanging the building. This can affect airflow and overhanging trees, or branches can damage the roof, it is advised to keep plants at a distance.

## 2 Repair

Inspect the interior and exterior of the product to look for splits, cracks, and holes. Although this is a natural occurrence it can be prevented. A wood filler can be used to close the splits, cracks, and holes.

## 3 Roof

Check your roof regularly for tears, splits, damaged wood and fallen debris. If you notice any of this immediate repair is critical.

## 4 Doors & Windows

Expansion and contraction can cause doors and windows to stick or become difficult to open. Small adjustments to the hinge position can be made to the doors and windows to allow free movement.

## 5 Oil

Hinges can seize up over time, apply lubricant to the hinges and locks annually.

## 6 Screws & Bolts

It is advised to check all screws and bolts and tighten any loose you might find. For log cabins specifically the storm braces will require loosening. During humidity and temperature changes (seasons) to allow expansion and contraction to prevent gapping, twisting, popping, and warping.

## 7 Wash

At least once a year, give the outside of you building a good wash, to remove cobwebs, leaves, or any other dirt that may accumulate on the exterior.

## 8 Airing

Airing your product regularly prevents the build up of condensation which can cause the timber to warp, bow, boards to pop, distortion, rot and mould. Condensation can build up over time or daily, it is caused by a rise and fall in temperature.

Excessive moisture levels within your building can cause water to collect on the roofs, walls and floors internally. Leaving doors and windows open regularly can help combat the natural moisture build up.

## 9 Storm Braces

The storm braces will need to be altered during the buildings life as the moisture content within the log boards changes, altering the braces will help your building expand and contract properly. The boards will expand during periods of high moisture (Winter) and shrink during periods of low moisture (Summer).

Ensure each bolt is tightened using a washer so as not to damage the log boards.

## 10 Clean & Tidy

It is good practice to clean the inside and outside of your product regularly. Clear out the contents, sweep the floor, remove dirt and cobwebs. Check for areas of damp and investigate the cause to remove and prevent future occurrences. Check the ground around your product for build up of debris such as leaves, remove and ensure there is clear ventilation underneath the floor.

### Additional Playhouse Maintenance:

It is recommended that the following checks and maintenance are carried out at the beginning of each season as well as at regular intervals during the usage season.

- Check all nuts /bolts/ screws for tightness and tighten when required.
- Check for movement / opening of wood giving rise to protrusion of nail heads and tips.
- Check hinges.
- Replace defective parts in accordance with the manufacturers instructions.
- Check any crossbeams, suspensions and anchors.
- If a swing is included; check the swing seat, chains and ropes.

**IF THESE CHECKS ARE NOT CARRIED OUT THE ACTIVITY TOY COULD BECOME A HAZARD**

All our garden buildings have been designed and manufactured with care and attention to be the perfect addition to your outdoor space. To ensure you do get the best out of your new garden building and to increase the longevity we advise that you follow the product instructions and our manufacturer's recommendations as detailed below. Thank you for choosing a Mercia Garden product!

## 1 Choosing the most suitable location for your garden building...

A minimum of 60cm should be left around the perimeter of your garden building to allow access for maintenance, annual treatment and to allow air flow around the building.

Where possible you should avoid placing your garden building underneath large trees to prevent the tree causing damage to the building.

## 2 Preparing the base for your garden building...

All our buildings must be built on a firm, level base to ensure the longevity of the building and prevent the wood from distorting. We recommend either concrete, concrete slabs or a wooden base, such as our 'Portabase'.

The base should be the same size as the building's floor bearer frame. These base dimensions are given on the first page of the contents. This will create a run off for water and preventing water from pooling underneath the building.

We also recommend that the floor of the garden building is a minimum of 25mm above the surrounding ground level to avoid flooding.

## 3 After installation...

Once your garden building has been installed, it will need to be treated within 14 days (weather permitting) and annually to prevent the timber from deteriorating and to waterproof it. This is required to maintain the anti-rot guarantee.

Dip Treated buildings - Require a preservative treatment to protect against rot and decay

and a waterproof treatment to prevent water ingress.

Pressure Treated buildings - Require a waterproof treatment to prevent water ingress.

Log Cabins/Insulated Garden Rooms - Are supplied untreated and require a preservative and waterproofing treatment.

We also recommend using a silicon sealant on the inside and outside of the windows as soon as possible after assembly and treatment to fully seal the windows.

Roofing felt/covering should be checked annually and replaced or fixed accordingly.

## 4 General maintenance and wood characteristics

As wood is a natural material it may be affected by the following:

Shrinkage and warping - The timber used in the construction of your garden building will have retained some of its natural moisture content. The moisture content of the timber will vary, depending upon prevailing environmental conditions, which will result in the components either naturally expanding or contracting. As the components dry out, shrinkage may occur. A good waterproofing treatment from the start is the best protection to minimise the effect of moisture loss/intake.

In extended periods of very warm weather getting some moisture to the building will help the overall balance. You can do this by spraying it down lightly with a garden hose. In contrast, after snow fall try to remove the snow as best as possible from the roof to prevent moisture intake and to remove the extra weight.

**Top tip** - using a garden brush will help you to reach the highest part of the building to remove snow and any debris left from bad weather.

Damp and mould - During the winter months, cold and damp conditions can result in an increased amount of moisture within your garden building, especially when used infrequently. Condensation can form on the timber and other items stored within your garden building. If left this moisture is likely to cause mould and mildew.

To prevent the build-up of moisture, we recommend leaving the door or windows of your building open from time to time, to allow the fresh air to circulate. We also advise against storing wet or damp items in your garden building as this will also increase the level of moisture in the building. If mould or mildew does start to form within your building we recommend using an anti-mould cleaner to remove it and to prevent it spreading, which if left untreated could permanently damage your garden building.

Splits, cracks and knots - You may notice small splits and cracks in some components or holes may appear where knots shrink and fall out. This will not affect the structure of your Garden building however, if you wish to fill them this can be easily done using any good quality wood filler.

Sap - is naturally occurring in wood and may appear in some boards of your garden building. If you wish to remove the sap, we advise waiting until it is dry and then using a sharp knife to carefully remove it. If the removal of the sap causes a hole in the timber, we recommend using a good quality wood filler to fill it.

For more handy hints and tips on how to care and maintain your garden building please refer to the MGP Customer Portal at [www.mgplogistics.co.uk](http://www.mgplogistics.co.uk)

### Any further questions?



Contact our Customer Service Team via the MGP Customer Portal at: [www.mgplogistics.co.uk](http://www.mgplogistics.co.uk)



## 1

### Manufacturer's Warranty

All Mercia Garden Products are supplied with a 1 year warranty on all parts against manufacturing defects.

This warranty does not cover movement, warping or splitting of timber products over time.

This warranty will be voided if any of the following occur:

1. The building has been customised or modified/adapted in any way.
2. The person claiming is not the original purchaser of the building.
3. Any damage has been caused by or as a result of misuse.
4. The building has not been maintained and cared for in accordance to our advisories and manufacturer's recommendations.
5. The building has not been treated annually or as per the manufacturer's recommendations, please ensure receipts are kept to validate this claim.
6. The building has not been erected, fitted or installed as per the supplier instructions.
7. The building has not been erected on a suitable sized firm flat, solid level concrete/slab base or placed on pressure treated bearers.
8. The building is or has been placed with 2 feet (600mm) of any obstructions (walls, trees, plants, fences etc.) which can allow moisture to penetrate the timber.
9. The roofing felt has been incorrectly fitted or damaged, allowing water ingress, or has not been properly maintained.
10. Any windows and joints have not been sealed, inside and out, with silicone or other watertight sealant.
11. Any timber has been cut, pierced or drilled without subsequent application of approved cut-end treatment.

REGISTER FOR YOUR  
**10 YEAR**  
**ANTI-ROT**  
GUARANTEE TODAY



[www.mgplogistics.co.uk](http://www.mgplogistics.co.uk)

## 2

### Anti-rot Guarantee

Mercia Garden Products offer a 10 year anti-rot guarantee on all dip treated (a preparatory treatment) and 15 years on all pressure treated products. This guarantee covers solid timber against rot, decay, blue stain and insect attacks.

To validate the guarantee, the building must be treated (as detailed within manufacturer's recommendations) within 14 days (weather permitting) of assembly and annually thereafter.

This guarantee does not cover movement, warping or splitting of timber products over time.

This guarantee will be voided if any of the following occur:

1. The building has been customised or modified/adapted in any way.
2. The person claiming is not the original purchaser of the building.
3. Any damage is caused by or as a result of misuse.
4. The building has not been maintained and cared for in accordance to our advisories and manufacturer's recommendations.
5. The building has not been treated annually or as per the manufacturer's recommendations, please ensure receipts are kept to validate this claim.
6. The building has not been erected, fitted or installed as per the supplier instructions.
7. The building has not been erected on a suitable sized firm flat, solid level concrete/slab base or placed on pressure treated bearers.
8. The building is or has been placed with 600mm of any obstructions (walls, trees, plants, fences etc.) which can allow moisture to penetrate the timber.
9. The roofing felt has been incorrectly fitted or damaged allowing water ingress, or has not been properly maintained.
10. Any windows and joints have not been sealed, inside and out, with silicone or other watertight sealant.
11. Any timber has been cut, pierced or drilled without subsequent application of approved cut-end treatment.