

0619VR3301-V1
19MM LOG CABIN - 3.3X1M VERANDA ADD ON PACK B

BEFORE YOU START PLEASE READ INSTRUCTIONS CAREFULLY

- Check the pack and make sure you have all the parts listed.
- When you are ready to start, make sure you have the right tools at hand (not supplied) including a Phillips screwdriver, Stanley knife, wood saw, step ladder and drill with 2mm bit.
- Ensure there is plenty of space and a clean dry area for assembly.

TIMBER

As with all natural materials, timber can be affected during various weather conditions. For the duration of heavy or extended periods of rain, swelling of the wood panels may occur. Warping of the wood may also occur during excessive dry spells due to an interior moisture loss. Unfortunately, these processes cannot be avoided but can be helped. It is suggested that the outdoor building is sprayed with water during extended periods of warm sunshine and sheltered as much as possible during rain or snow.

BUILDING A BASE

When thinking about where the building and base are going to be constructed: Ensure that there will be access (60mm) to all sides for maintenance work and annual treatment.

Ensure the base is level and is built on firm ground, to prevent distortion. Refer to diagrams for the base dimensions. The base should be slightly smaller than the external measurement of the building, i.e. The cladding should overlap the base, creating a run off for water. It is also recommended that the floor be at least 25mm above the surrounding ground level to avoid flooding.

TYPES OF BASE

- Concrete 75mm laid on top of 75mm hard-core.
- Slabs laid on 50mm of sharp sand.

Whilst all products manufactured are made to the highest standards of Safety and in the case of childrens products independently tested to EN71 level, we cannot accept responsibility for your safety whilst erecting or using this product.

Refer to the instructions pages for your specific product code



All buildings should be erected by two adults



Winter = High Moisture = Expansion
Summer = Low Moisture = Contraction



2mm Drill bit

For ease of assembly, you **MUST** pilot drill all screw holes and ensure all screw heads are countersunk.



CAUTION
Every effort has been made during the manufacturing process to eliminate the prospect of splinters on rough surfaces of the timber. You are strongly advised to wear gloves when working with or handling rough sawn timber.



For ease of assembly use a rubber mallet to fit the log boards. Do **NOT** use a heavy hammer.



Ensure to measure and check before cutting boards.



It is advisable to use a hand saw when cutting roof and floor boards.



To ensure log boards are even, use a spirit level to check each layer has been installed correctly.

Screws & Nails



Bolts



To identify the fixings required for each step use a measuring tape.

For assistance please contact customer care on: 01636 821215

Mercia Garden Products Limited,
Sutton On Trent,
Newark,
Nottinghamshire,
NG23 6QN

www.merciagardenproducts.co.uk



Overall Dimensions:
 Width = 3258mm
 Depth = 1000mm
 Height = 870mm

Base Dimensions:
 Width = 3230mm
 Depth = 902mm

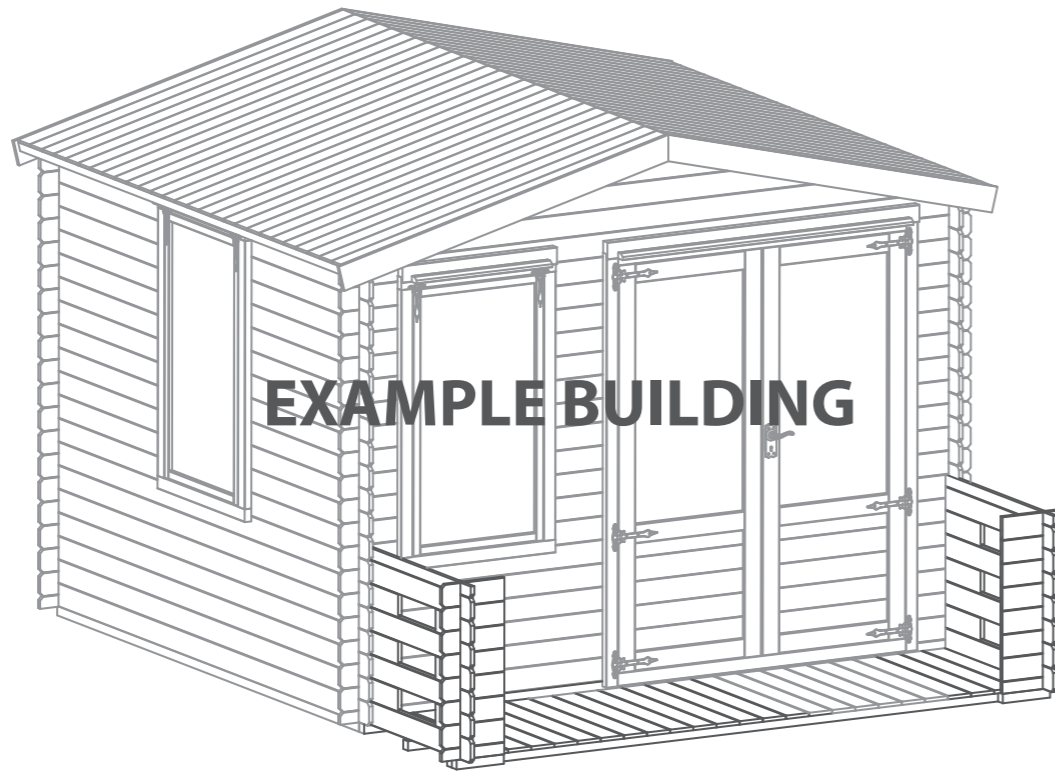

Nail Bag

There may be extra screws present in the nail bag

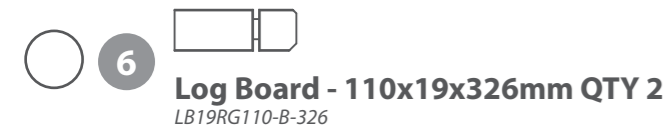
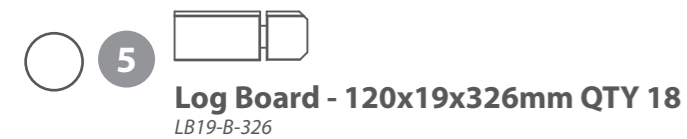
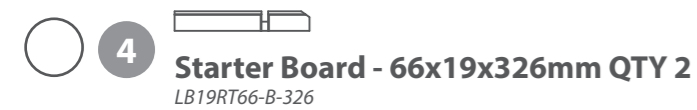
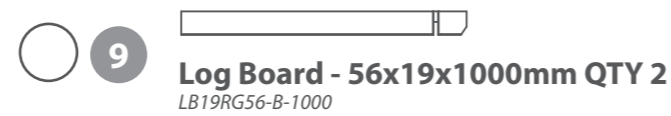
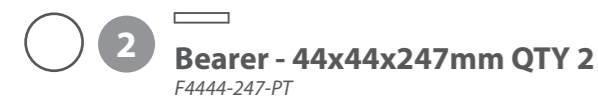
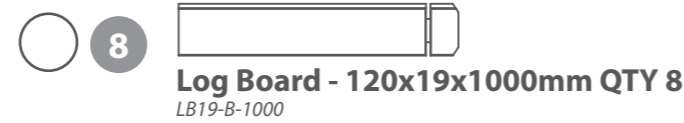
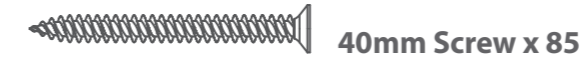

Pre-assembly

***Please note:**

Each board interlocks at either end in a staggered pattern.

Before securing ensure that the boards are fitted properly in their respective tongues and grooves.

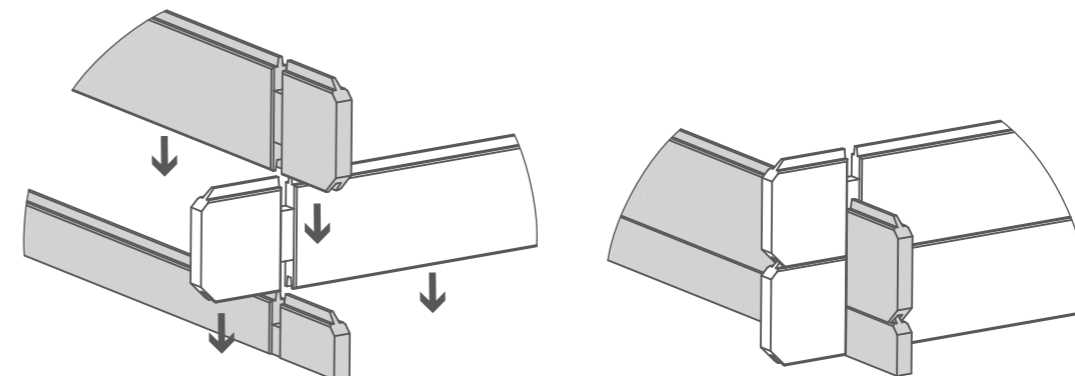

Pre-Assembly

Follow the instructions for the 19mm Log Cabin
(0619AXNE3326HGDD2SW-V1 OR 0619AXNE3303HGDD2SW-V1)

Your Log cabin should be fully assembled before starting the Veranda.

Your building should look as shown.

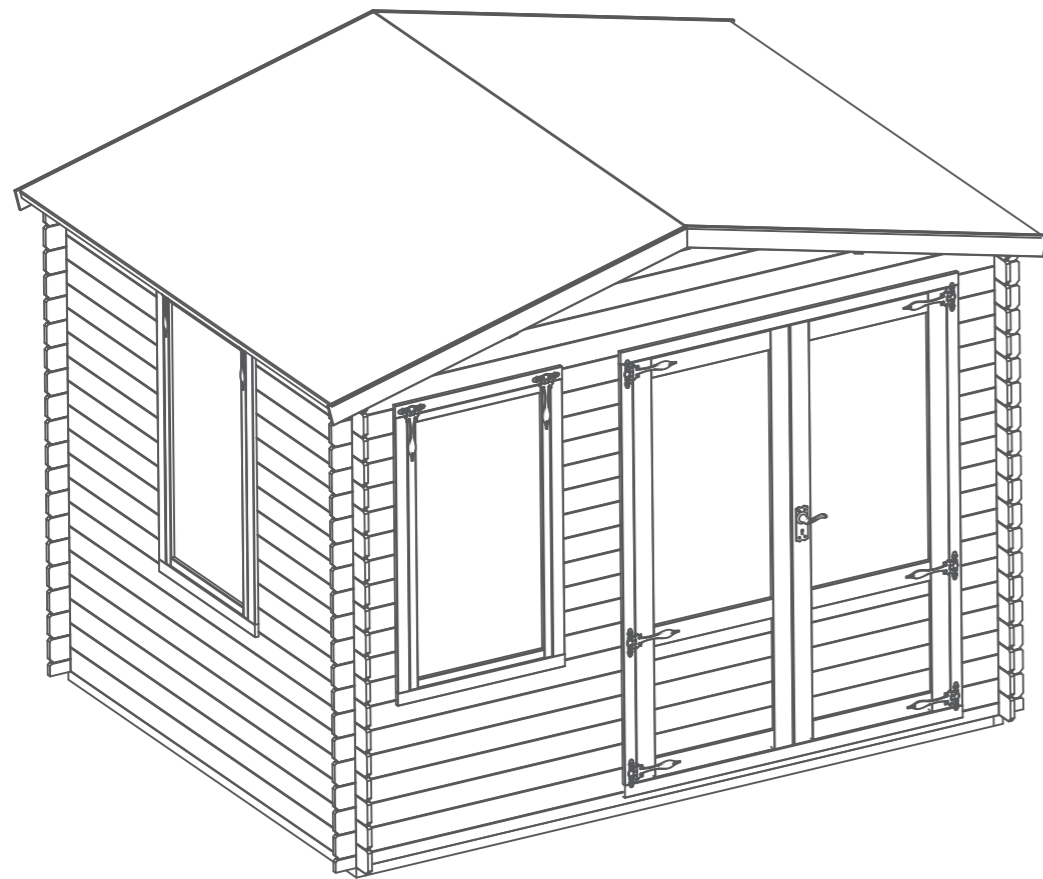

Step 1

Parts Needed - No. 1 QTY 3

No. 2 QTY 2

a Place the first Bearer (No. 1) up to the log cabin and fix to the log cabin bearer using 4x70mm screws.

b Attach one small bearer (No. 2) to each end of the third-larger bearer using 4x70mm screws.

8x70mm Screws



Pre drill hole



70mm screw

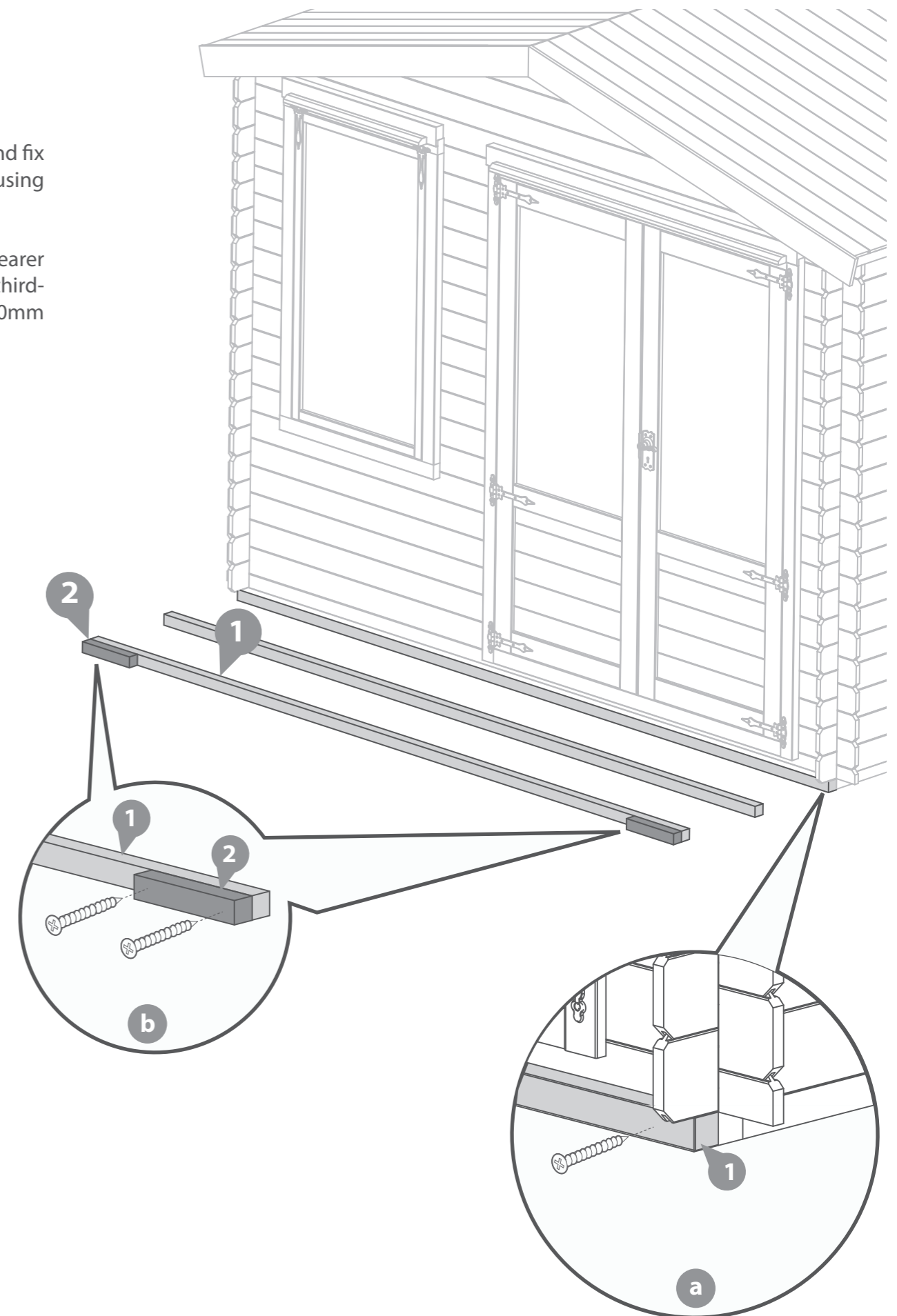

Step 2

**Parts Needed - No. 4 QTY 2
No. 8 QTY 2**

Following the method outlined in the illustration, secure one starter board (**No. 4**) onto each of the small bearers (**No. 2**), using 1x70mm screws per board, ensuring to screw through the notch into the bearer below. Make sure that the end of starter board (**No. 4**) is flush with end of the small bearer (**No. 2**).

Place the first two log boards (**No.8**) onto the starter boards (**No.4**) and rest onto the bearers as shown in the illustration.

Once in position fix the log board to the inside of the cabin using 2x40mm screws per log board.

**The centre bearer at this point is not fixed into position, arrange so that the bearer is central.*

**4x40mm Screws
2x70mm Screws**

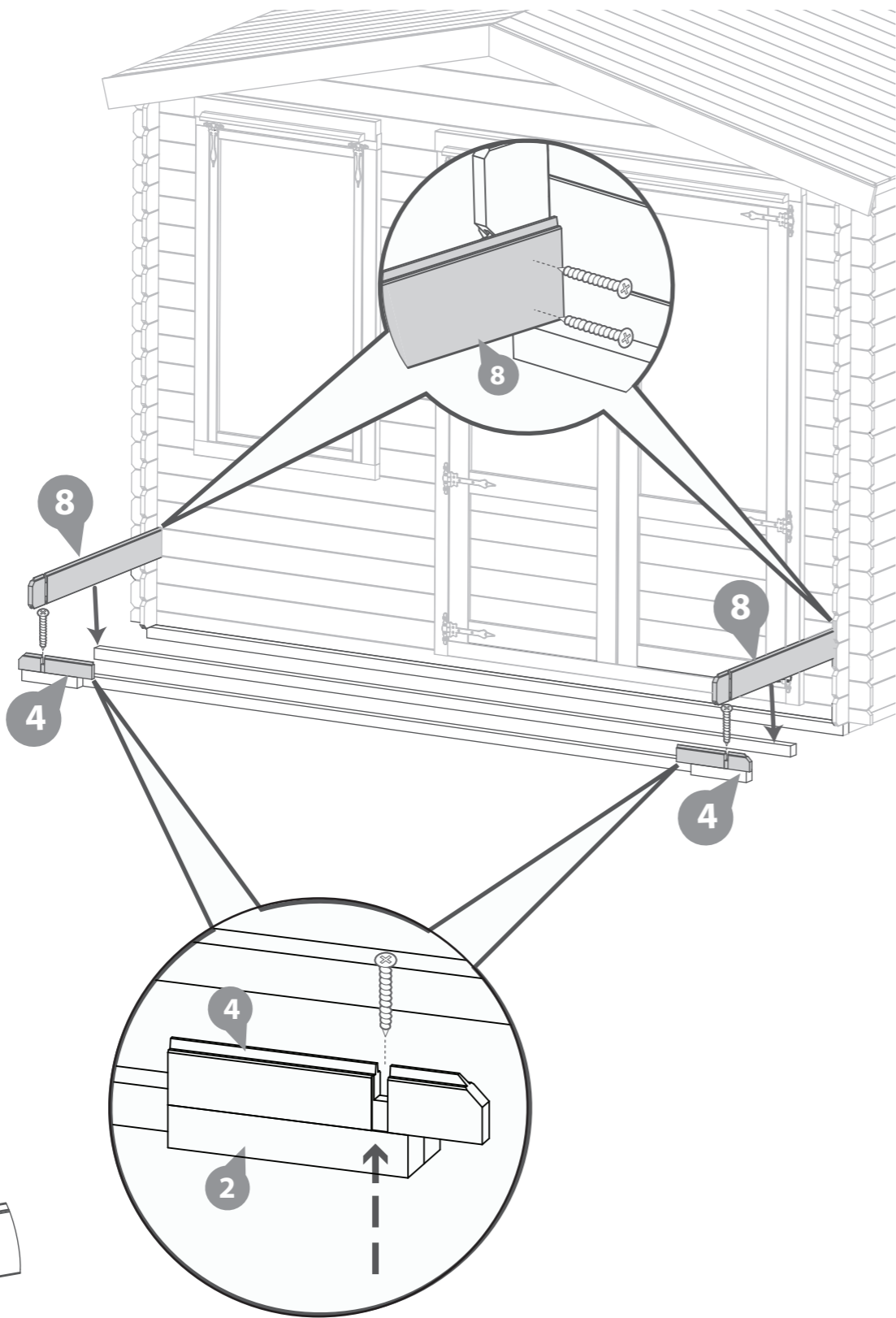
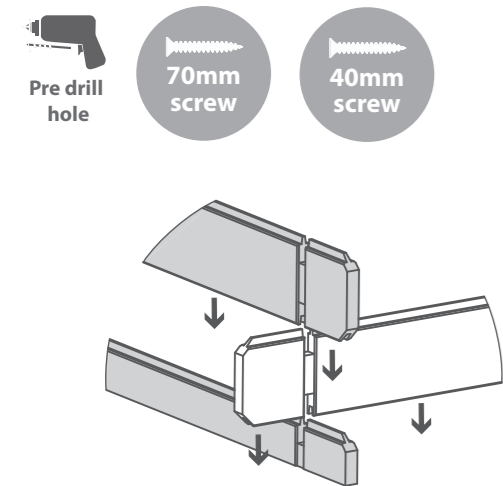

Step 3

**Parts Needed - No. 5 QTY 18
No. 6 QTY 2
No. 7 QTY 6
No. 8 QTY 6**

Following the method outlined in the illustration, continue placing the boards (**No. 5, 7 & 8**) on to the veranda sides as shown in the illustrations, ensuring to interlock the boards.

Once in position fix the top log board (**No.6**) on each side to the inside of the cabin using 2x40mm screws per log board.

4x40mm Screws

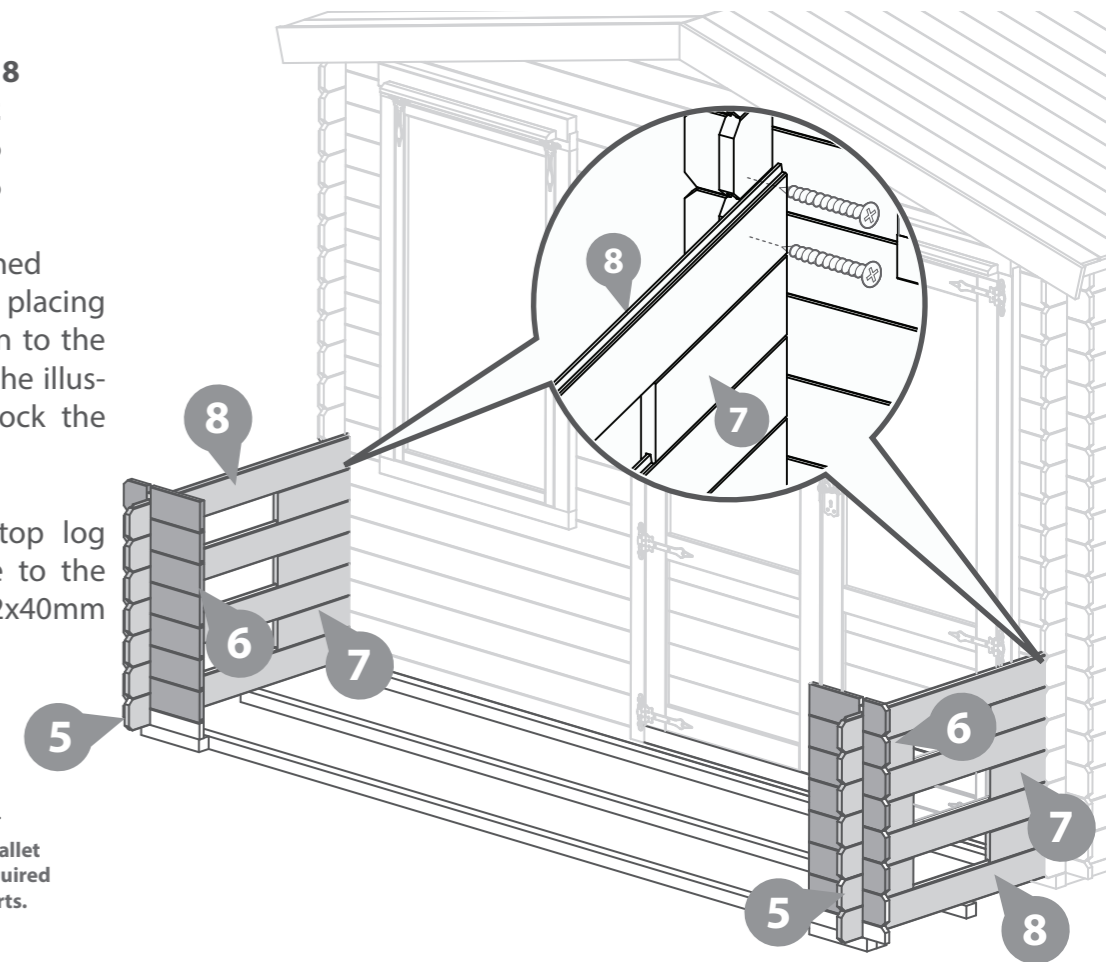
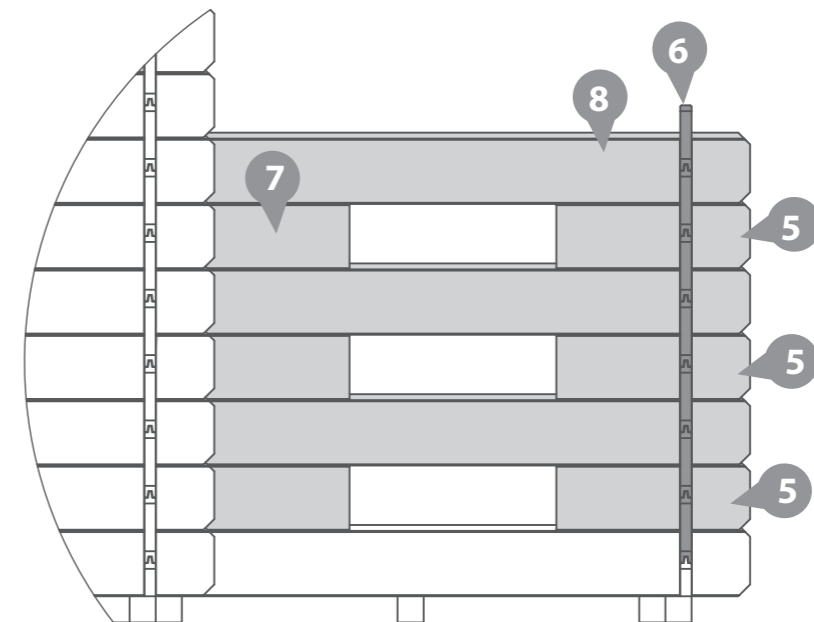
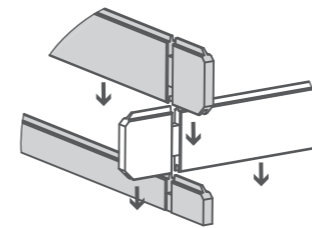
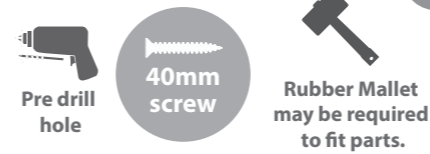

Step 4

Parts Needed - No. 3 QTY 25

Place the Floor Boards (**No. 3**) onto the bearers and secure each board into place using 3x40mm screws, ensuring to screw through the boards into the bearers below.

75x40mm Screws



Pre drill hole



40mm screw

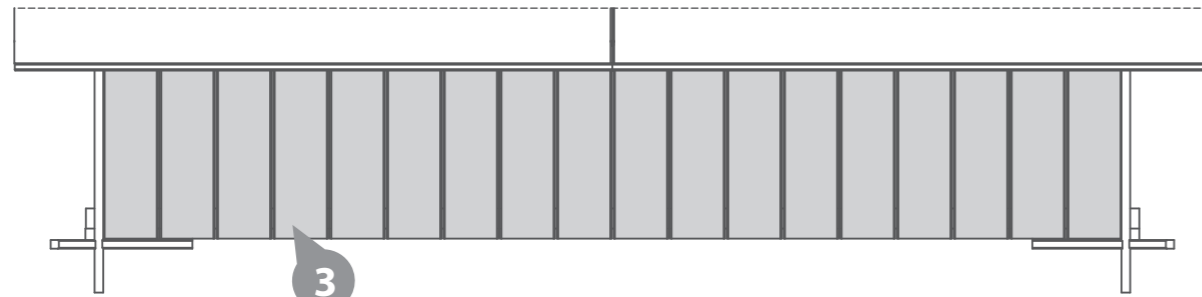

Step 5

Parts Needed - No. 9 QTY 2

Fix the last two log boards (**No.9**) onto the veranda sides using 1x70mm screws per board through the notches and 2x40mm screws per board through the boards as shown in the illustration.

2x40mm Screws 2x70mm Screws



Pre drill hole



70mm screw

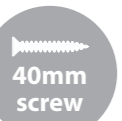

40mm screw



Rubber Mallet may be required to fit parts.

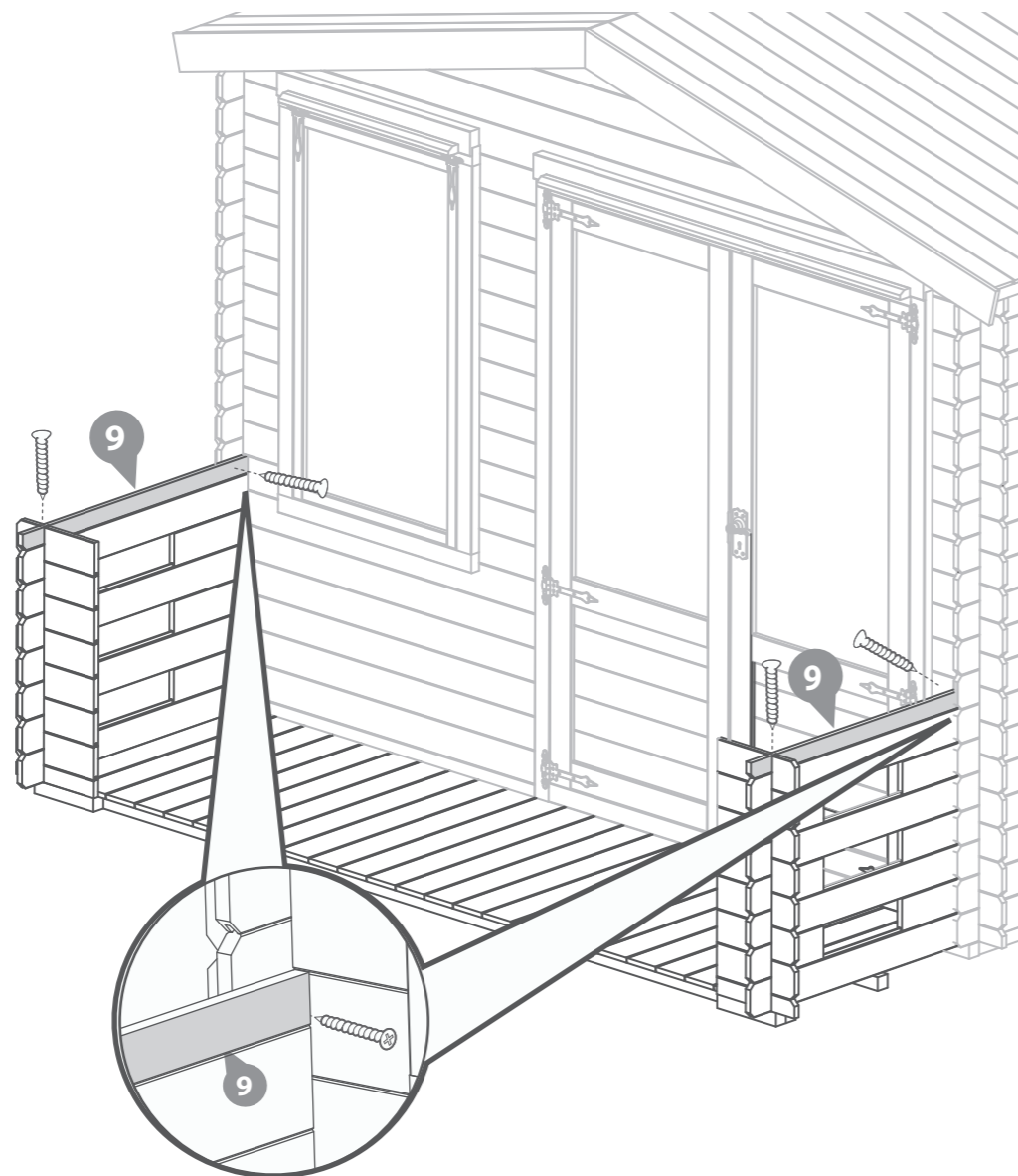
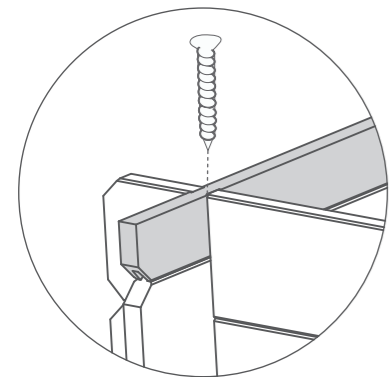

It is **ESSENTIAL** that you apply wood treatment immediately after the building has been assembled.

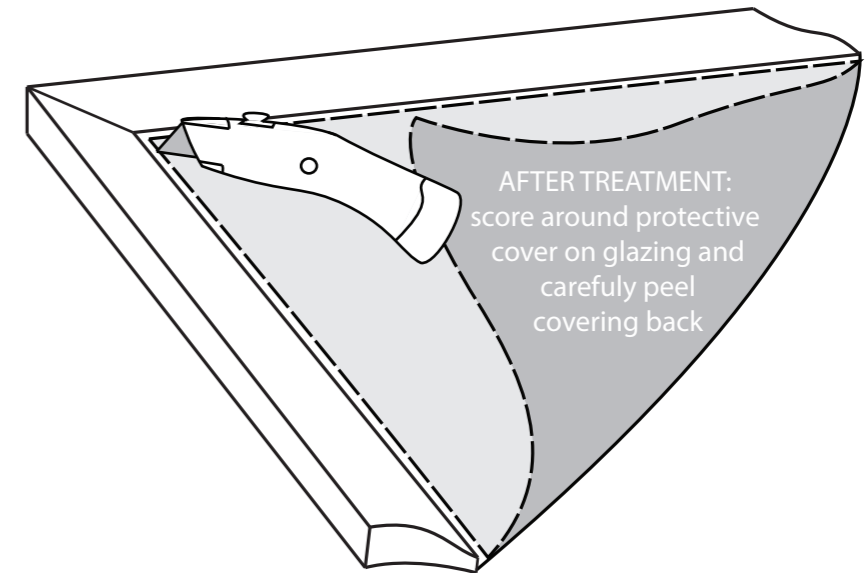

AFTER TREATMENT: score around protective cover on glazing and carefully peel covering back

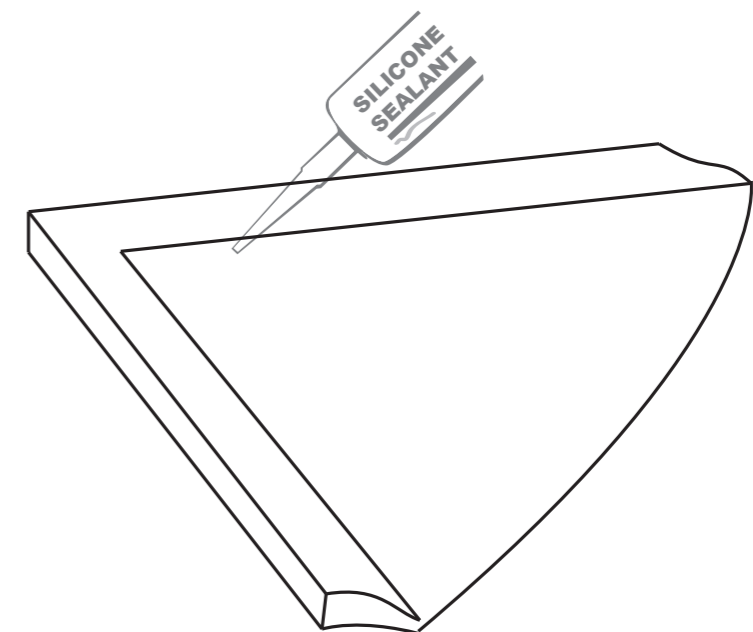

SILICONE SEALANT

It is **ESSENTIAL** to seal around all window framing with silicone sealant (not included) to minimise water ingress.