

0628PNSLPA0303NDNW-V1
28MM LOG CABIN 3M X 3M PENT SLATTED PATIO AREA ADD ON.

BEFORE YOU START PLEASE READ INSTRUCTIONS CAREFULLY

- Check the pack and make sure you have all the items listed in the parts list provided.
- When you are ready to start, make sure you have the right tools at hand (not supplied - see the equipment list on next page).
- Ensure you have enough time to build the product to ensure the building is water tight.

LOCATION FOR YOUR GARDEN BUILDING

A minimum of 600mm should be left around the perimeter of your garden building to allow access for maintenance, annual treatment and to allow air flow around the building.

Where possible you should avoid placing your garden building underneath large trees to prevent the tree causing damage to the building.

TIMBER

As with all natural materials, timber can be affected during various weather conditions. For the duration of heavy or extended periods of rain, swelling of the wood panels may occur. Warping of the wood may also occur during excessive dry spells due to an interior moisture loss. Unfortunately, these processes cannot be avoided but can be helped. It is suggested that the outdoor building is sprayed with water during extended periods of warm sunshine and sheltered as much as possible during rain or snow.

Once your garden building has been installed it will need to be treated within 14 days (weather permitting) and annually to prevent the timber from deteriorating and to waterproof it. This is required to maintain the anti-rot guarantee.

Log Cabins/Insulated Garden Rooms - Are supplied untreated and require a preservative and waterproofing treatment.

BUILDING A BASE

When thinking about where the building and where the base is going to be constructed: Ensure that there will be access to all sides for maintenance work and annual treatment.

Ensure the base is level and is built on firm ground, to prevent movement. Refer to the contents page for the base dimensions. The base should be slightly smaller than the external measurement of the building, i.e. The cladding should overlap the base, creating a run off for water. It is also recommended that the floor be at least 25mm above the surrounding ground level to avoid flooding.

TYPES OF BASE

- Concrete 75mm laid on top of 75mm hard-core.
- Slabs laid on 50mm of sharp sand.
- Wooden base - Levelled / on posts / ground screws.

Whilst all products manufactured are made to the highest standards of safety and in the case of children's products independently tested to EN71 level, we cannot accept responsibility for your safety whilst erecting or using this product.



x2 All buildings should be erected by two adults



Winter = High Moisture = Expansion
 Summer = Low Moisture = Contraction



2mm Drill bit

For ease of assembly, you **MUST** pilot drill all screw holes and ensure all screw heads are countersunk.



CAUTION

Every effort has been made during the manufacturing process to eliminate the prospect of splinters on rough surfaces of the timber. You are strongly advised to wear gloves when working with or handling rough sawn timber.



For ease of assembly use a rubber mallet to fit the log boards. Do NOT use a heavy hammer.



Ensure to measure and check before cutting boards.

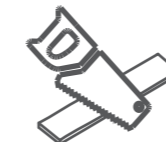

It is advisable to use a hand saw when cutting roof and floor boards.



To ensure log boards are even, use a spirit level to check each layer has been installed correctly.

Screws & Nails



Measure overall length

Bolts



Measure under the head

To identify the fixings required for each step use a measuring tape.

REGISTER FOR YOUR

ANTI-ROT

GUARANTEE TODAY

PLEASE SCAN HERE:

In all instances for assistance with your product, please contact us via our customer portal: <https://www.mgplistics.co.uk/>.

Mercia Garden Products Limited,
 Sutton On Trent,
 Newark,
 Nottinghamshire,
 NG23 6QN



TO DO LIST

- Find a suitable location to build *(see front cover for further information).*
- Build a base *(see front cover for further information).*
- Check the base is flat, level, clear of debris and has 60cm clearance on all sides.
- Check you have the required equipment / tools.
- Check you have all the product items listed *(if you have missing or damaged parts please scan the QR code below to visit our online customer portal)*
- Install the product as per the step by step instructions within this pack.
- Prepare the product ready for treatment (This may include sanding).
- Apply a preserving and a waterproofing treatment within 14 days *(weather permitting)* of installation.
- Register for your anti rot guarantee *(scan the QR below).*
- Tidy the build area and dispose of any remaining parts responsibly.
- Maintain your building *(see the manufacturers recommendations at the back of this pack).*

EQUIPMENT LIST

- Hammer
- Mallet
- Flat Head Screwdriver
- Drill
- Drill Bit Set
- Phillips and Slotted Bit Sets
- Tape Measure
- Hand Saw
- Spirit Level
- Ladders/Steps
- Stanley Knife/Cutting Tool
- Sand Paper
- Gloves
- Silicone (For Windows Only)
- Wood Filler (Optional)
- Timber Preservative Treatment
- Timber Water Proofing Treatment
- Treatment Mixing Stick
- Paint Brush/Sprayer/Roller

NEED EXTRA SUPPORT

If you are unsure that your base preparation will be suitable, please contact us via our customer portal to discuss this further.

Alternatively, you can visit our website or MGP Logistics Online Portal for some further sheducation.

Website:

<https://www.merciagardenproducts.co.uk/sheducation>

MGP Logistics Online Portal:

<https://www.mgplogistics.co.uk/>

Here you will find plenty of useful information that'll help with most pre-installation and maintenance queries.

PLEASE SCAN HERE:



ANY QUESTIONS?

Scan the QR code to contact us via our customer portal.

NOTES

Before assembly please make sure you have a suitable base ready to erect your building



MADE IN GREAT BRITAIN

PLEASE SCAN HERE:



ANY QUESTIONS?
Scan the QR code to contact us via our customer portal.

Overall Dimensions: Width = 2988mm
Depth = 3334mm
Height = 2494mm



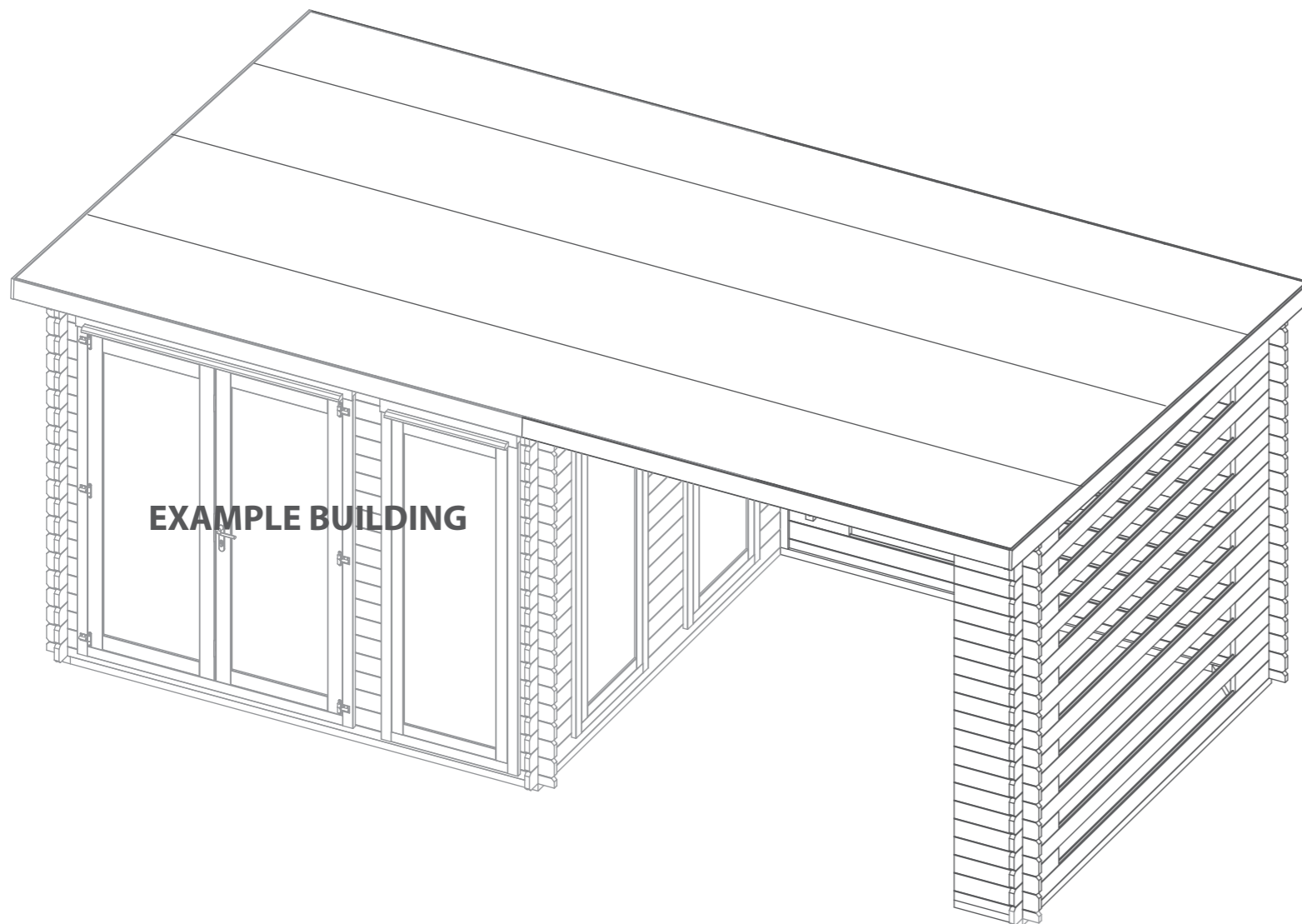







Base Dimensions: Width = 2874mm
Depth = 2782mm











Tip: Labelling your parts, using a pencil and masking tape, may help you to identify them easier when you need them.



Log Boards Contents:

- 1  **Starter Board - 28x66x2949mm QTY 1**
LB28RT66-B-2949mm
- 2  **Starter Board - 28x66x500mm QTY 1**
LB28RT66-B-500mm
- 3  **Log Board - 28x120x2974mm QTY 10**
LB28-A-2974mm
- 4  **Log Board - 28x120x2949mm QTY 10**
LB28-B-2949mm
- 5  **Log Board - 28x120x500mm QTY 50**
LB28-B-500mm
- 6  **Log Board - 28x120x376mm QTY 10**
LB28-C-376mm
- 7  **Log Board - 28x120x2970mm QTY 1**
LB28-B-2970mm
- 8  **Finisher Board - 28x50x2949mm QTY 1**
LB28RG50-B-2949mm
- 9  **Finisher Board - 28x50x2970mm QTY 1**
LB28RG50-B-2970mm
- 10  **Gable QTY 1**
AI-0628LOGPNPA3-G-V1
- 11  **Gable Point QTY 1**
AI-0628LOGPNPA3-G-V1

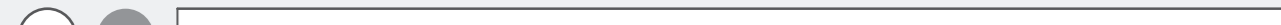





Fixing Kit Contents:

- 
12 Floor Bearer - 44x44x2782mm QTY 1
F4444-2782mm-PT
- 
13 Floor Bearer - 44x44x2830mm QTY 1
F4444-2830mm-PT
- 
14 Floor Bearer - 44x44x360mm QTY 1
F4444-360mm-PT
- 
15 Floor Bearer - 44x44x440mm QTY 2
F4444-G-440mm-PT (2x45 deg cuts, 400mm finished length)
- 
16 Purlin - 45x120x2972mm QTY 2
F45120-B-2972mm
- 
17 Roof Board - 16x121x3300mm QTY 27*
MB16-3300mm
- 
18 Eaves Frame - 27x44x2874mm QTY 2
F2744-2874mm
- 
19 Fascia - 16x120x3000mm QTY 2*
S16120-3000mm
- 
20 Closure Trim - 16x28x2400mm (approx length) QTY 3*
S1628-2400mm
- 
21 Storm Brace - 44x27x2000mm QTY 5
F2744-2000mm

**This part will be longer than needed and requires cutting to size when used. This will be explained when required within the instruction step.*

Note: one piece may be required to be cut into multiple different sizes. Do not dispose of off-cuts until the building is fully constructed as they may be needed in another step.

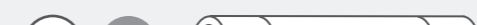
Fixing Kit Contents:

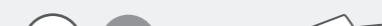
- 
22 Strip - 16x60x2222mm QTY 1
S1660-2222mm
- 
23 L-Frame - 44x44x2222mm QTY 1
LF4444-2222mm
- 
24 2mm Spacer QTY 5
PI-07-0208 (20x100x2mm)
- 
25 Sand Capping Felt
- 
26 Sand Felt
- 
27 Green Felt
- 
28 Butyl QTY 2
PI-01-0042

Screw Pack.

There may be extra screws present in the pack.

- | | | | |
|---|---------------------------|---|-------------------------|
|  | 70mm Bolt Set x 10 |  | 40mm Screw x 116 |
|  | 70mm Screw x 27 |  | 30mm Screw x 42 |
|  | 50mm Screw x 12 |  | Felt Tacks x 300 |

Pre-assembly

***Please note:**
Each board interlocks at either end in a staggered pattern.

Before securing ensure that the boards are fitted properly in their respective tongue's and groove's.

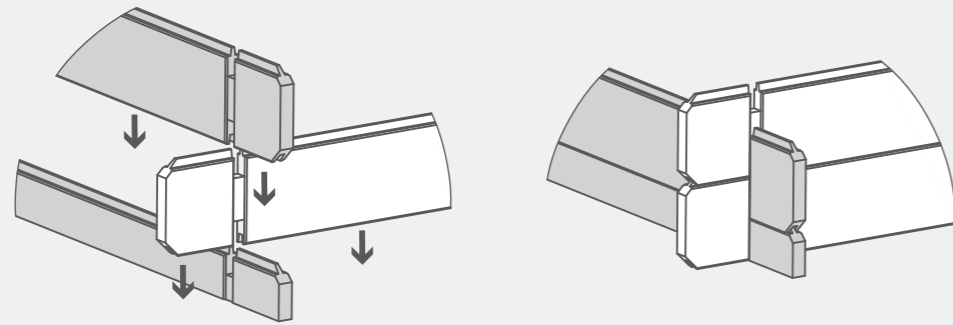

Pre-Assembly

Before beginning construction of your Patio area, please follow the instructions to construct your chosen log cabin, however **DO NOT** attach or cut down the last roof board, Felt or the Fascia trims.

Not attaching these parts allows the extension to be fixed in place.

Your building should look as shown:

(0628PNNE0303FGDD3TW-V1)
(0634PNNE0303FGDD3TW-V1)
(0644PNNE0303FGDD3TW-V2)

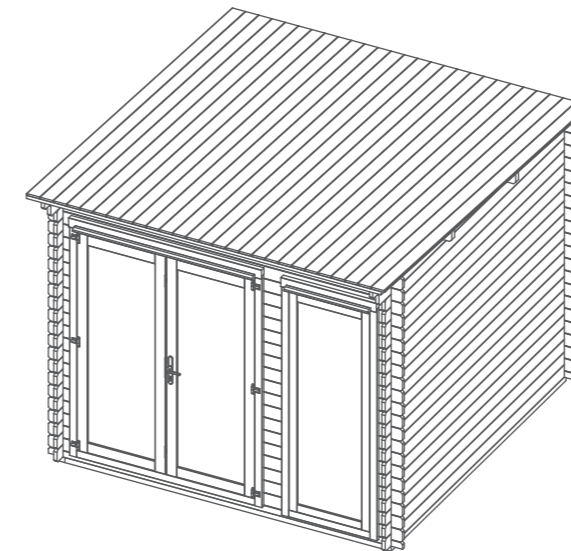

(0628PNNE0403FGDD4TW-V1)
(0634PNNE0403FGDD4TW-V1)
(0644PNNE0403FGDD4TW-V1)

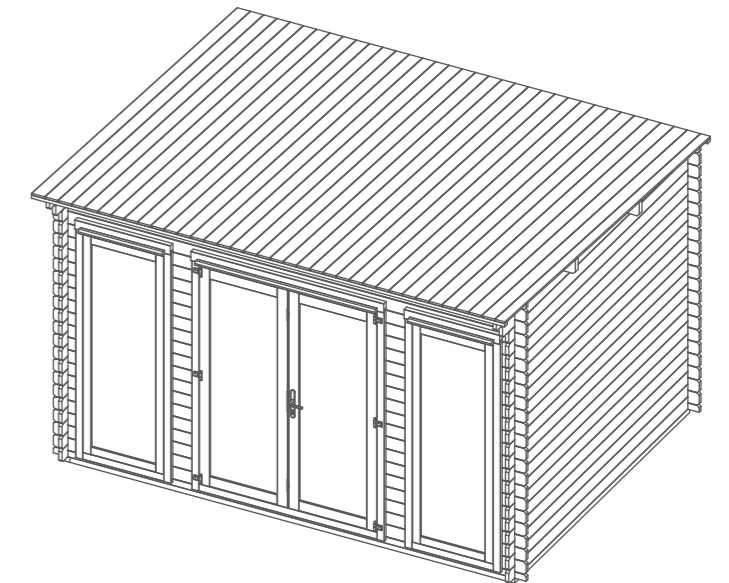

(0628PNNE0303HGDD1TW-V1)

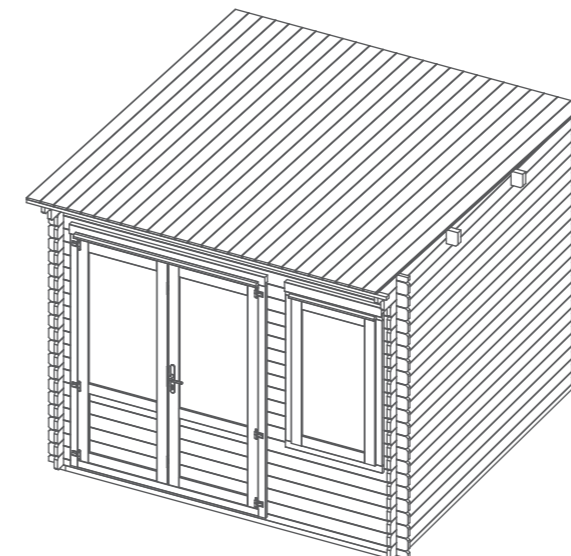

PLEASE SCAN HERE:



Missing parts?

Scan the QR code to visit our customer portal where you can quickly raise any missing or damaged parts and get a replacement sent out ASAP.



Step 1

Parts Needed - No. 12 QTY 1 No. 14 QTY 1
No. 13 QTY 1 No. 15 QTY 2

Lay the bearers (No. 12, 13, 14 & 15) onto a firm and level base (free from areas where standing water can collect) ensuring the bearers are level and flush as shown.

Fix the bearers together at each corner using 2x70mm screws per corner.

***Please note: For illustrative purposes the patio area will be constructed on the right hand side of the log cabin, however, you can position the patio area on either side of the log cabin.**

12x70mm Screws

Important: Pre-drill before fixing screws.

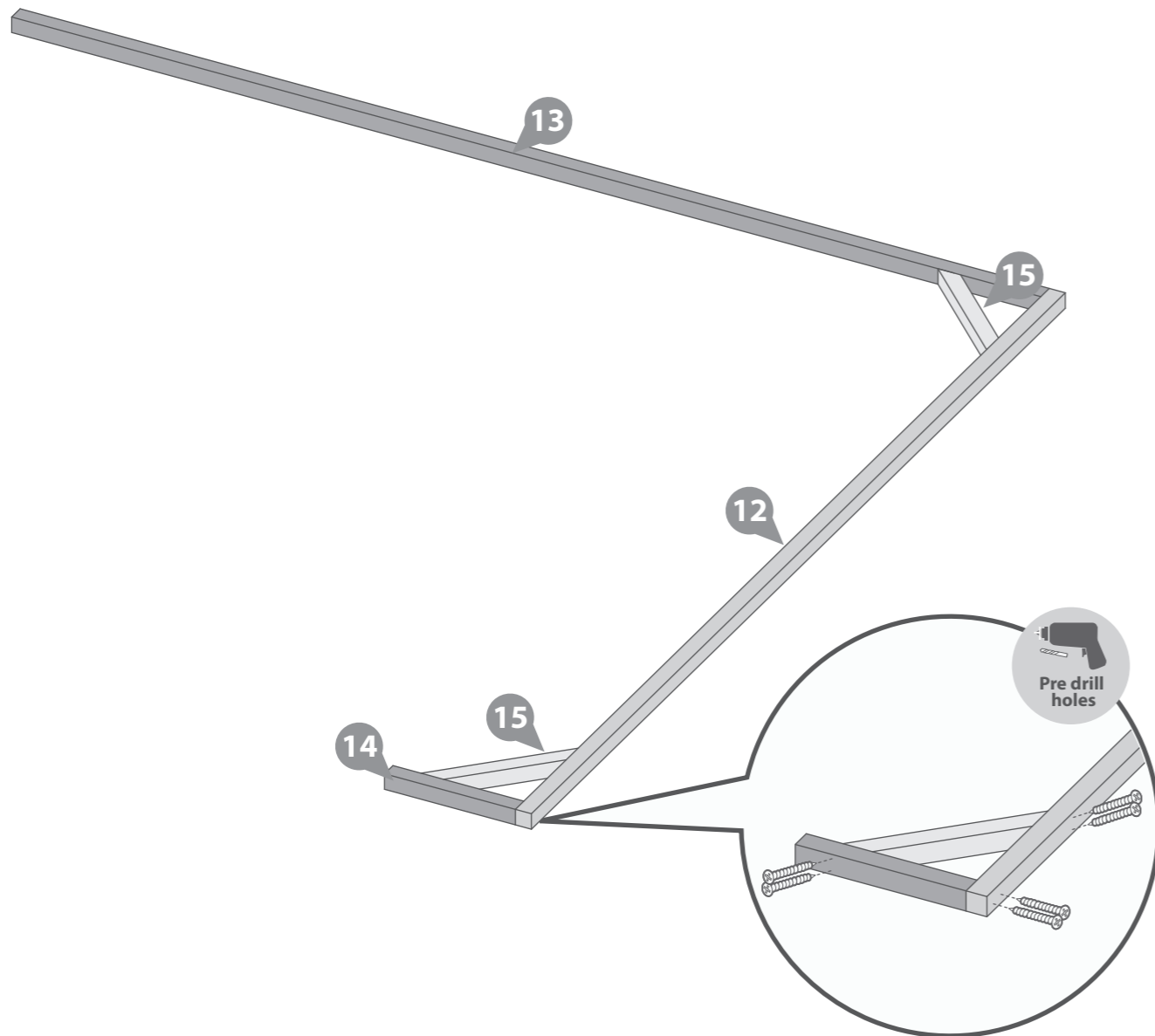
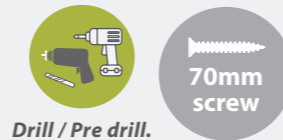

Step 2

***Please note: For illustrative purposes the patio area will be constructed on the right hand side of the log cabin, however, you can position the patio area on either side of the log cabin.**

Lay the assembled bearers up against the Log Cabin as shown, ensuring the bearers are level and flush with each other and those on the log cabin.

***Please note: At the back of the log cabin, there will be a gap between the log cabin bearers and the patio bearers. The position of your bearers will depend on the thickness of your Cabin's log boards. If you Cabin's boards are 28mm, the bearer should sit 22mm away from the cabins back log board. If you Cabin's boards are 34mm or 44mm, the bearer should sit 16mm away from the cabins back log board.**

Secure the bearers to the cabin's bearers using 70mm screws. Direct the screws through at an angle to fix into the cabins bearers. Ensure that the bearers remain level.

Once fully assembled, ensure the bearers are square by measuring from corner to corner as illustrated, making sure the measurements are equal. If the bearers are not aligned equally, unscrew, adjust and re-align accordingly.

Ensure the bearers are positioned correctly by using a long board to check that when the board is positioned on top of the front bearer (No.13) and is flush to the front, the board sits in front of the Cabin's front log board. If not, unscrew and re-align.

***Please note: The Log cabin used in the step is for illustrative purposes only and may differ from your choice in building, however the process of constructing the bearers is the same.**

2x70mm Screws

Important: Pre-drill before fixing screws.

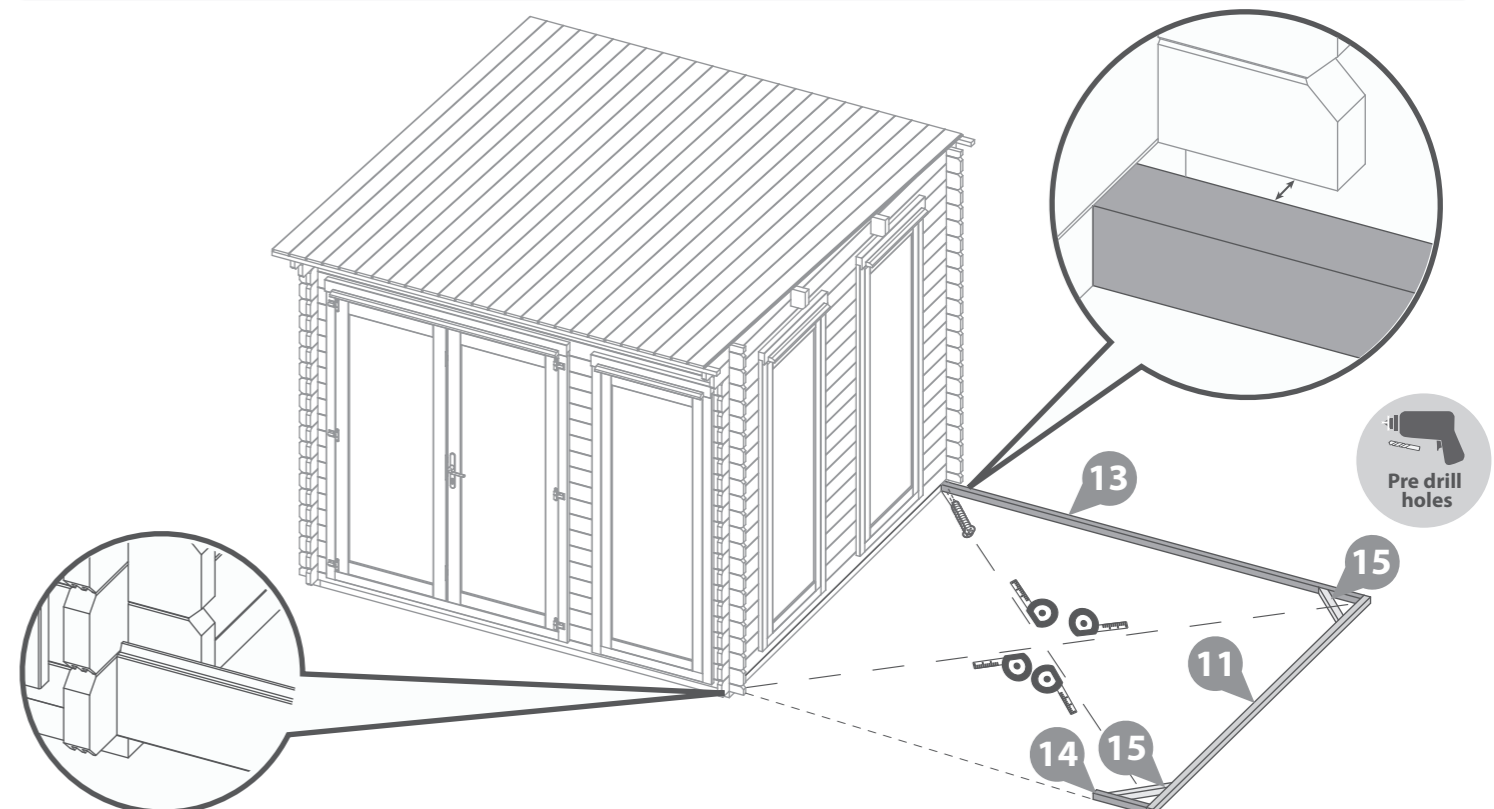

Step 3

**Parts Needed - No. 22 QTY 1
No. 23 QTY 1**

Place the 'L Frame' (**No.23**) and the Strip (**No. 22**) flush together, creating a 'U' shaped channel, as shown in the illustration.

Fix together using 6x30mm screws.

6x30mm Screws

Important: Pre-drill before fixing screws.



Drill / Pre drill.



70mm screw

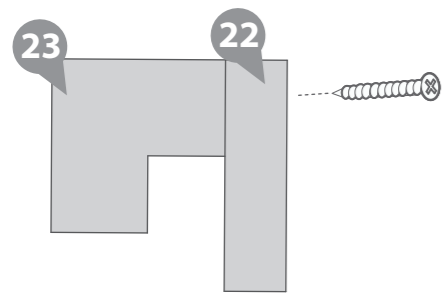

Aerial View

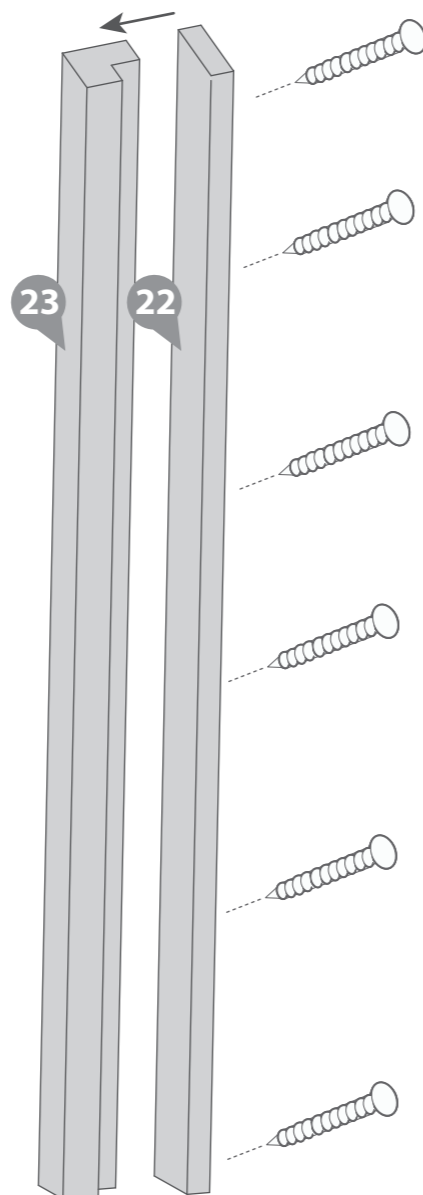

Pre drill holes

Step 4

**Parts Needed - No. 1 QTY 1
No. 2 QTY 1
No. 3 QTY 1**

Place the starter boards (**No. 1 & 2**) on to the assembled base frame along the front and the back, and lightly position the first log board (**No. 3**) on the notches as shown.

Note: Use a mallet and a scrap piece of wood to gently fix the log boards into position.

Locate the 'U' Channel (if you have not yet constructed your 'U' channel please refer to Step 3) so it is flush to the side of the log cabin's log boards, and the 'U' channel sits around the starter board (**No. 1**).

The starter board (**No.1**) should sit flush to the back of the back bearer, and the back strip of the 'U' channel should overhang this bearer, as shown in the illustration.

Depending on the board thickness of your log cabin, there may be a gap between the back of the U-channel and the log cabins log boards.

****Ensure the measurement between the 'U' channel and log cabins log boards is equal at the top and bottom of the 'U' channel.**



Rubber Mallet.

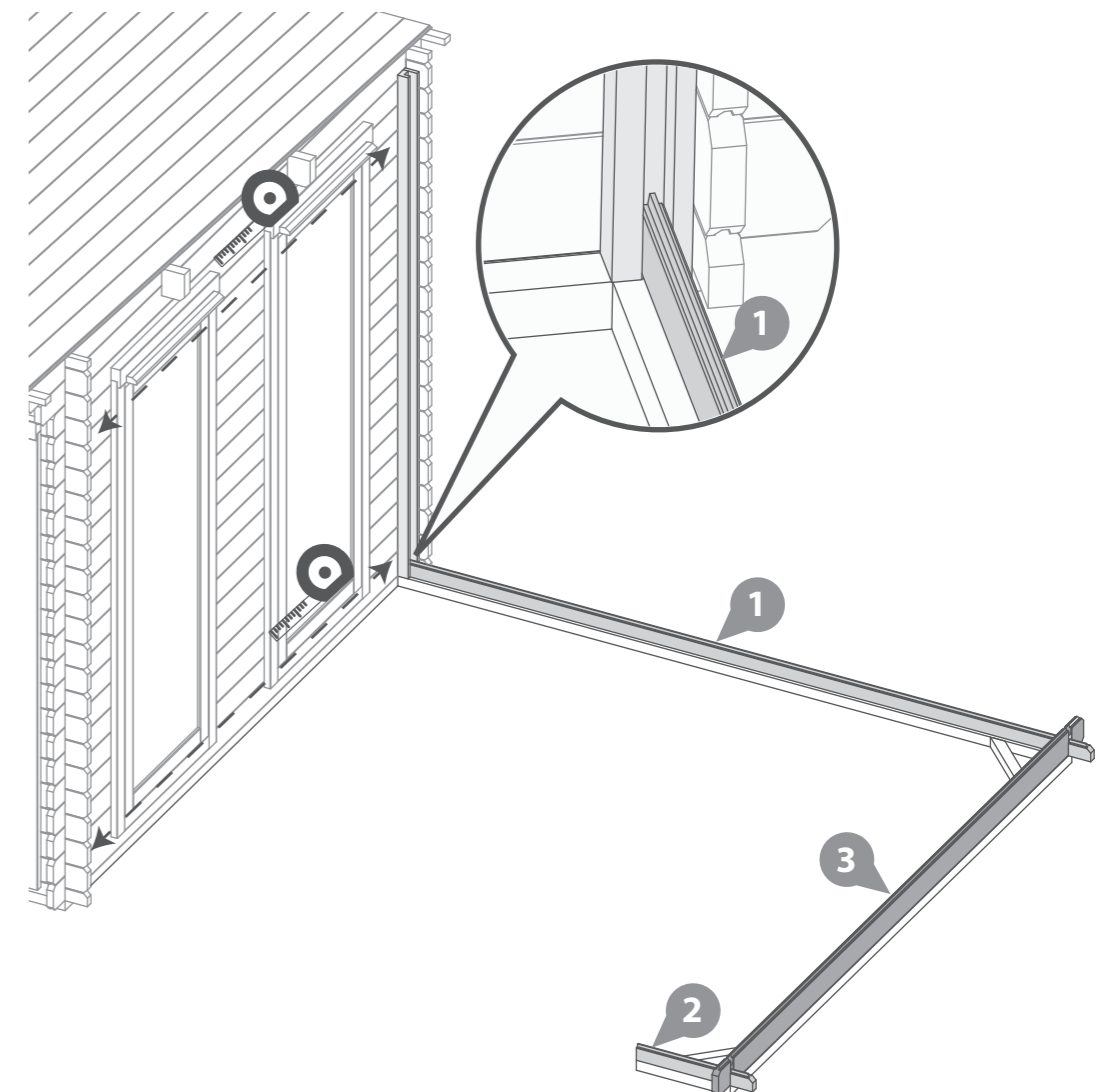

Step 5

- Parts Needed - No. 1 QTY 1
- No. 2 QTY 1
- No. 3 QTY 1

Ensure the boards sit square on the base using the same method used in Step 2. Measure corner to corner, making sure the measurements are equal.

Once the boards are square, lift up the log board (No. 3) and fix the starter boards (No. 1 & 2) in place by screwing through the notches into the bearer using 1x70mm screw per notch, as shown in the illustration.

2x70mm Screws

Important: Pre-drill before fixing screws.

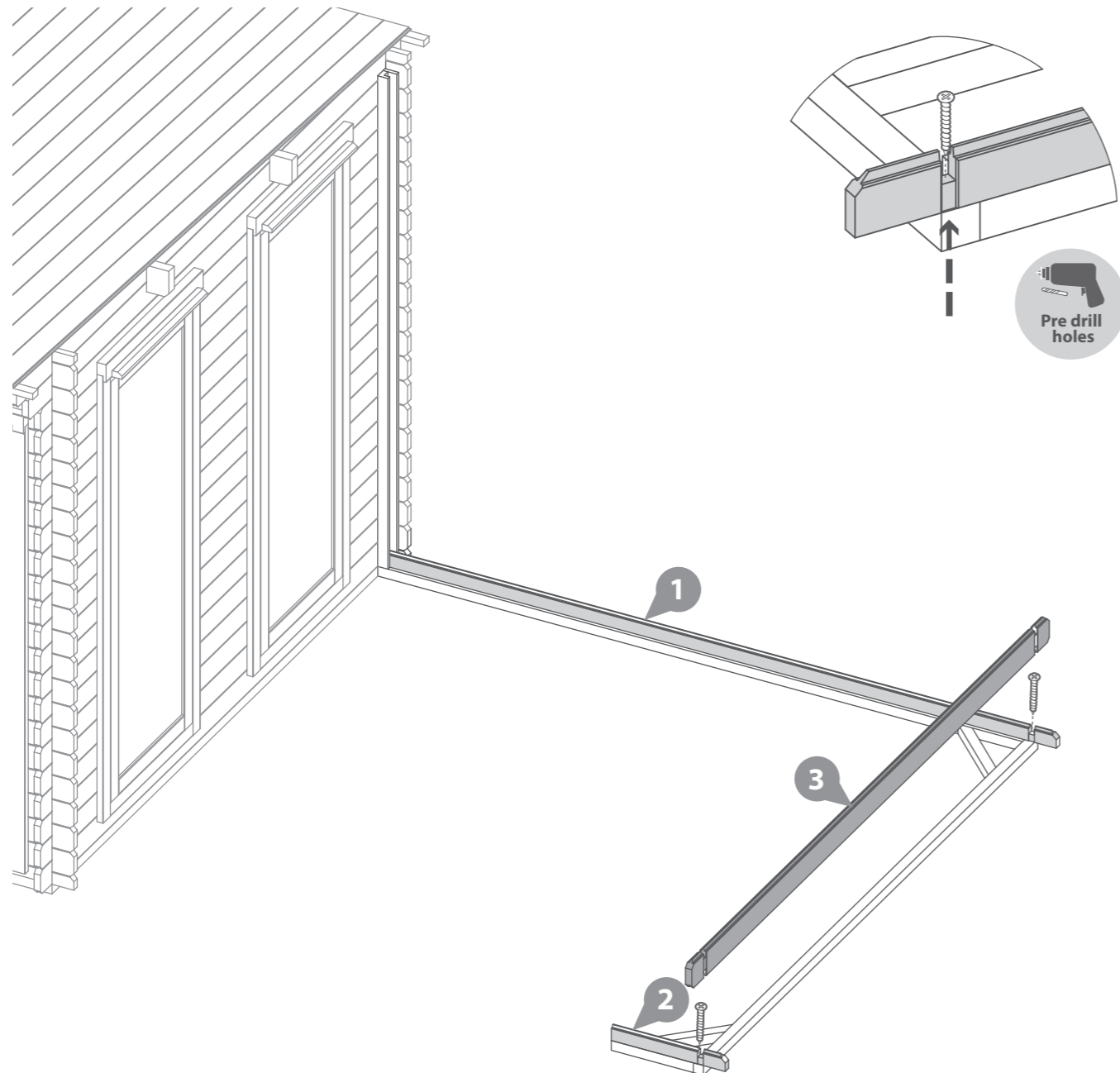

Step 6

Fix the 'U' channel in place by screwing through the 'L frame' into the log boards behind using 6x30mm screws.

****Ensure the measurement between the 'U' channel and log cabins log boards is equal at the top and bottom of the 'U' channel.**

6x30mm screws.

Important: Pre-drill before fixing screws.

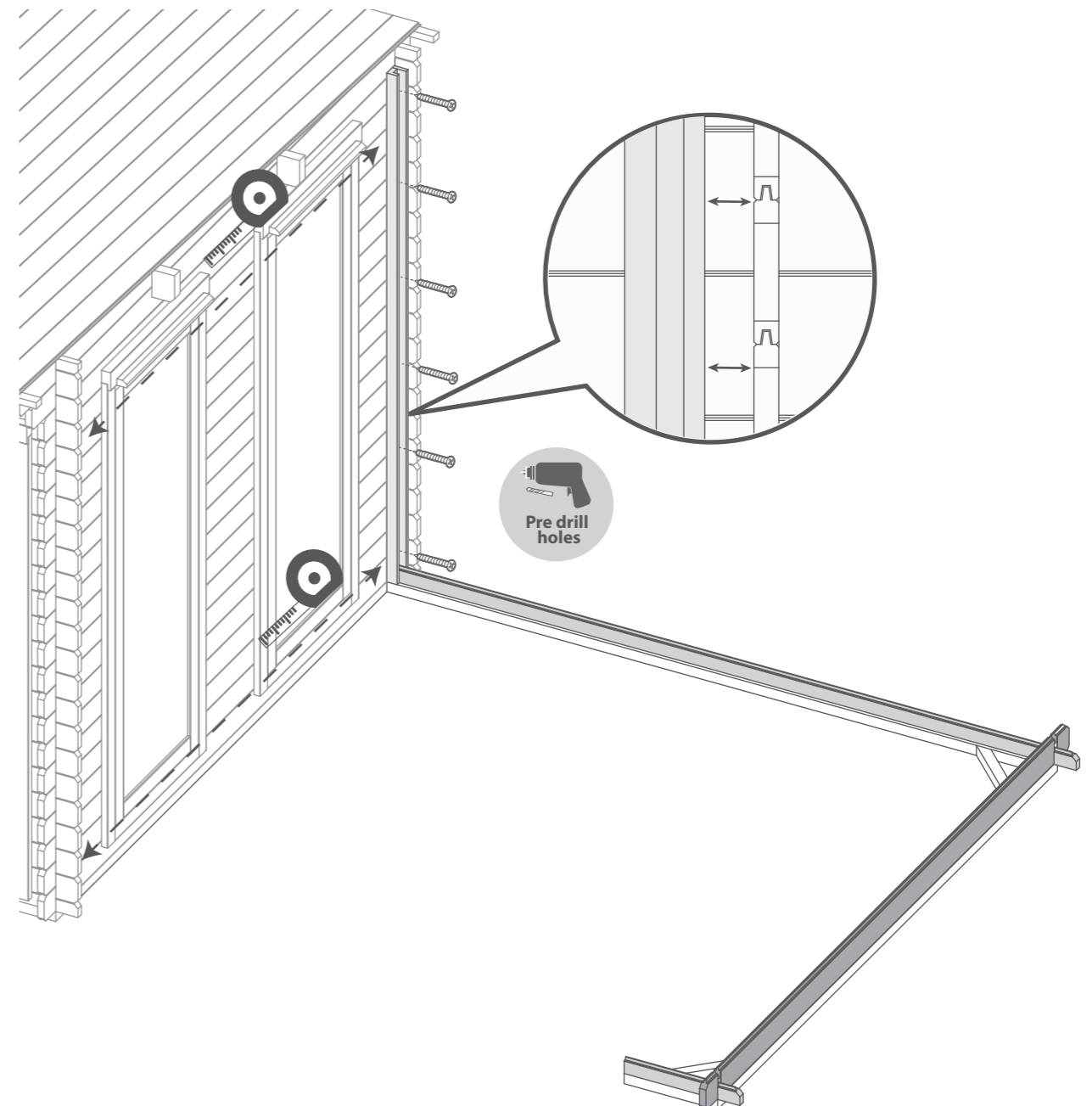

Step 7

- Parts Needed - No. 3 QTY 3**
- No. 4 QTY 3**
- No. 5 QTY 15**
- No. 6 QTY 3**

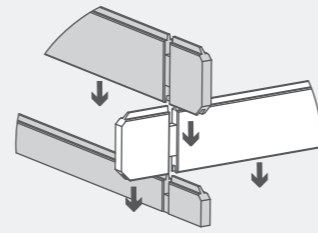

Following the method shown in the illustration, lay the first 6 boards (**No. 3,4,5 & 6**) off of the starter boards to create your first level, ensuring that the back log boards (**No. 4 & 6**) sit inside the 'U' channel.

Ensure to lay the boards in the order shown to create the slatted affect.

**Ensure that the boards are level and flush with each other as you lay each one.*

Secure the back top board (**No.6**) by screwing through the Log board at an angle into the 'U' channel, using 2x50mm screws.

2x50mm screws.
Important: Pre-drill before fixing screws.



Step 8

- Parts Needed - No. 3 QTY 3**
- No. 4 QTY 3**
- No. 5 QTY 15**
- No. 6 QTY 3**

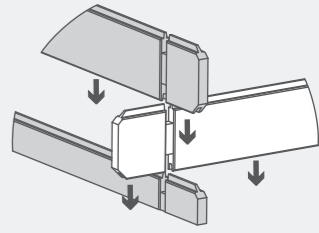

Following the method shown in the illustration, lay the next 6 boards (**No. 3,4,5 & 6**) to create your second level, ensuring that the back log boards (**No. 4 & 6**) sit inside the 'U' channel.

Ensure to lay the boards in the order shown to create the slatted affect.

**Ensure that the boards are level and flush with each other as you lay each one.*

Secure the back top board (**No.6**) by screwing through the Log board at an angle into the 'U' channel, using 2x50mm screws.

2x50mm screws.
Important: Pre-drill before fixing screws.

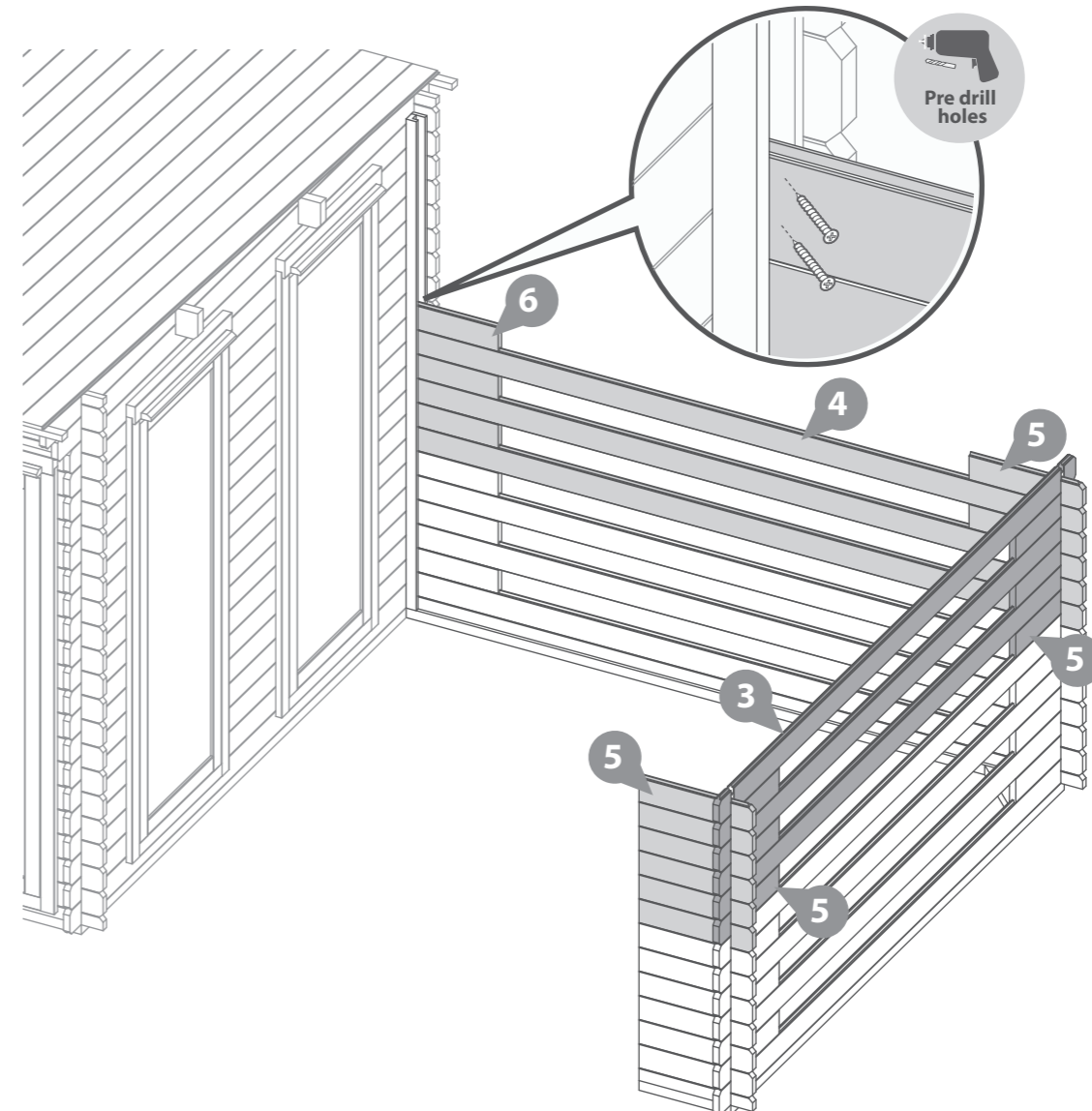
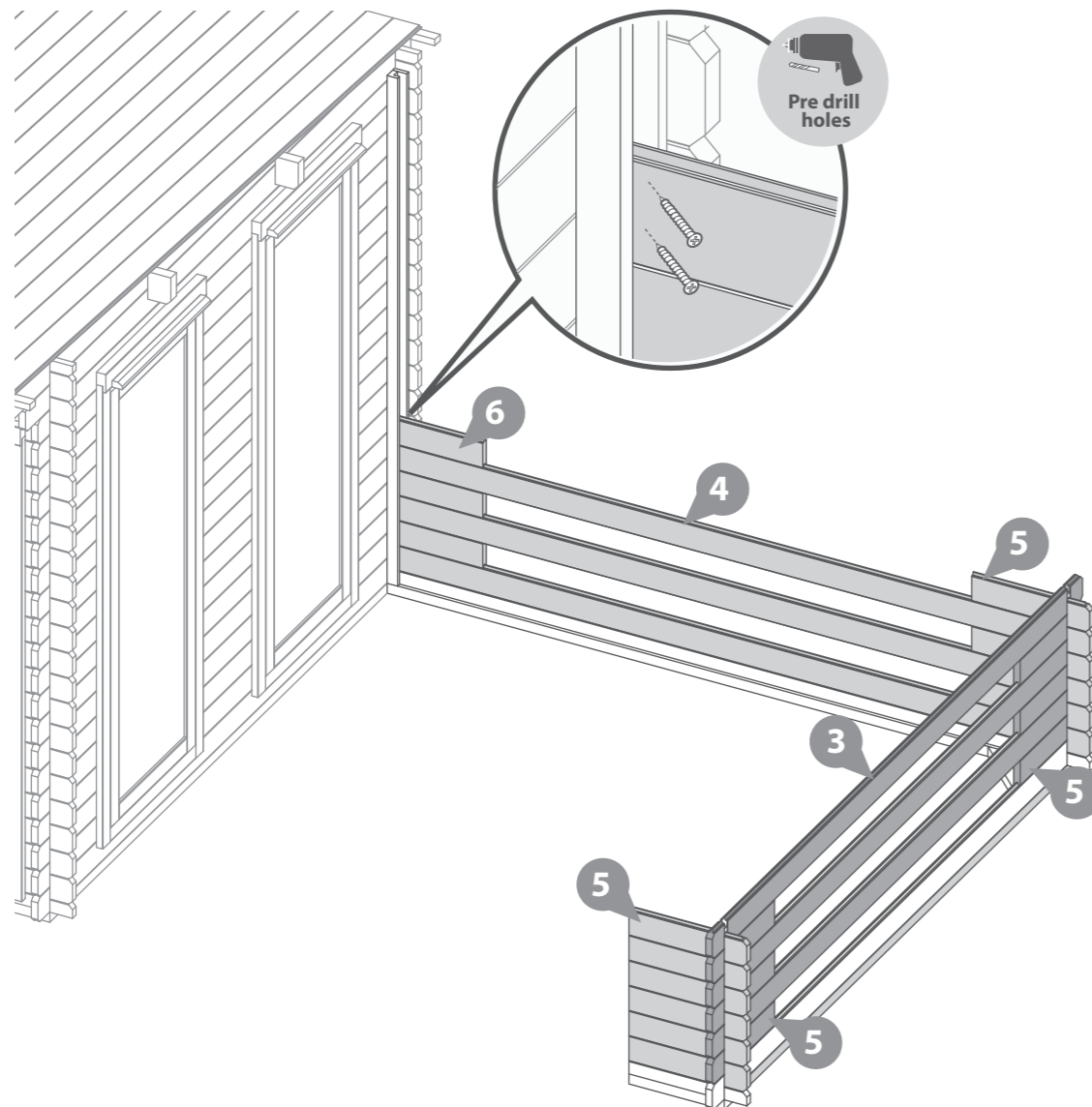

Step 9

- Parts Needed - No. 3 QTY 3**
- No. 4 QTY 3**
- No. 5 QTY 15**
- No. 6 QTY 3**

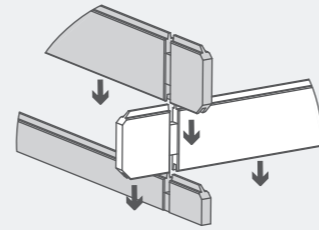

Following the method shown in the illustration, lay the next 6 boards (**No. 3,4,5 & 6**) to create your next level, ensuring that the back log boards (**No. 4 & 6**) sit inside the 'U' channel.

Ensure to lay the boards in the order shown to create the slatted affect.

***Ensure that the boards are level and flush with each other as you lay each one.**

Secure the back top board (**No.6**) by screwing through the Log board at an angle into the 'U' channel, using 2x50mm screws.

2x50mm screws.
Important: Pre-drill before fixing screws.

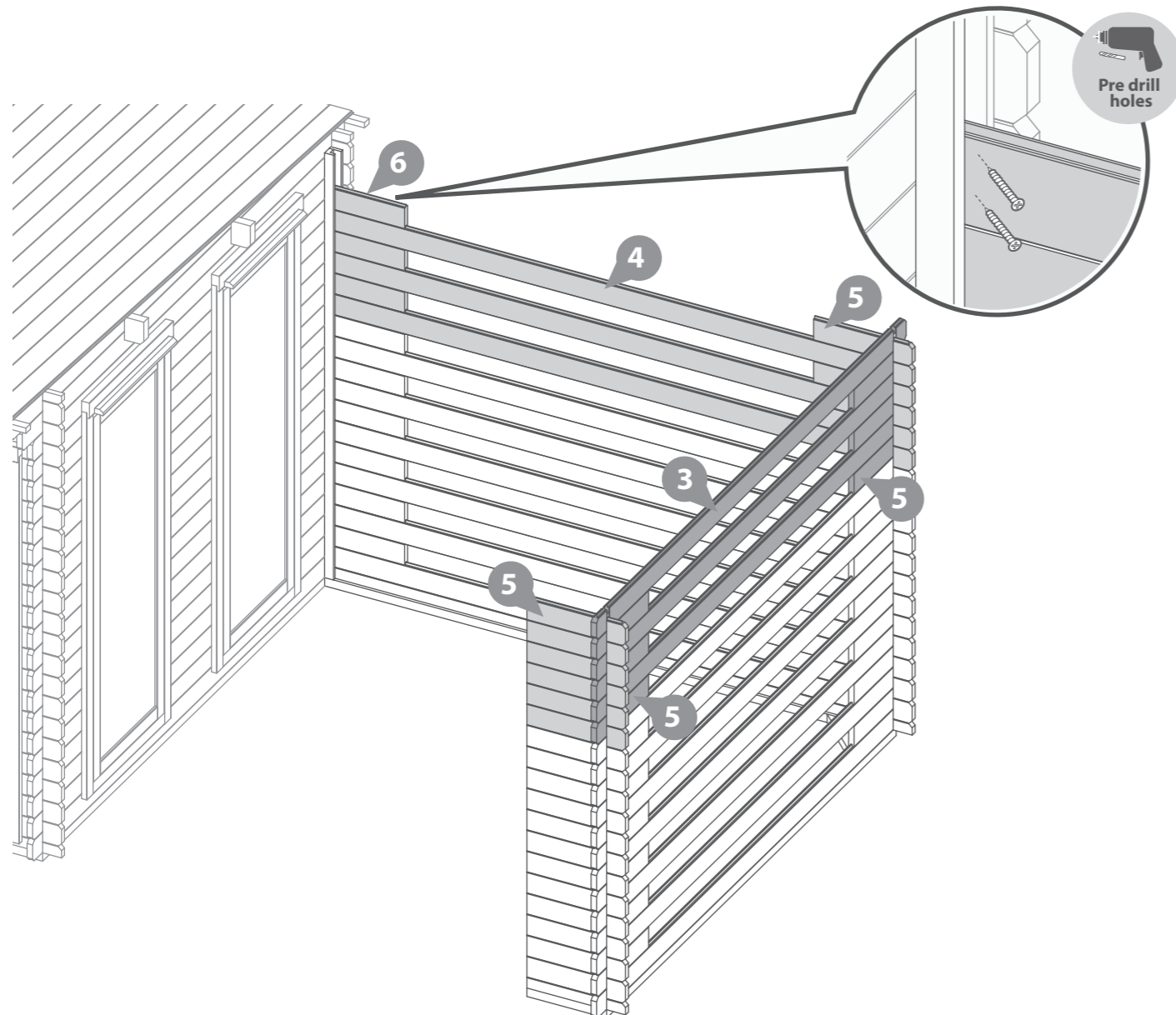

Step 10

- Parts Needed - No. 4 QTY 1**
- No. 5 QTY 3**

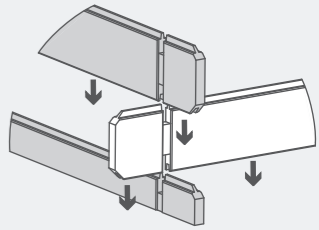

Following the method shown in the illustration, lay the next 6 boards (**No.4 & 5**) to create your next level, ensuring that the back log board (**No. 4**) sits inside the 'U' channel.

Ensure to lay the boards in the order shown to create the slatted affect.

***Ensure that the boards are level and flush with each other as you lay each one.**

Secure the back top board (**No.4**) by screwing through the Log board at an angle into the 'U' channel, using 2x50mm screws.

2x50mm screws.
Important: Pre-drill before fixing screws.

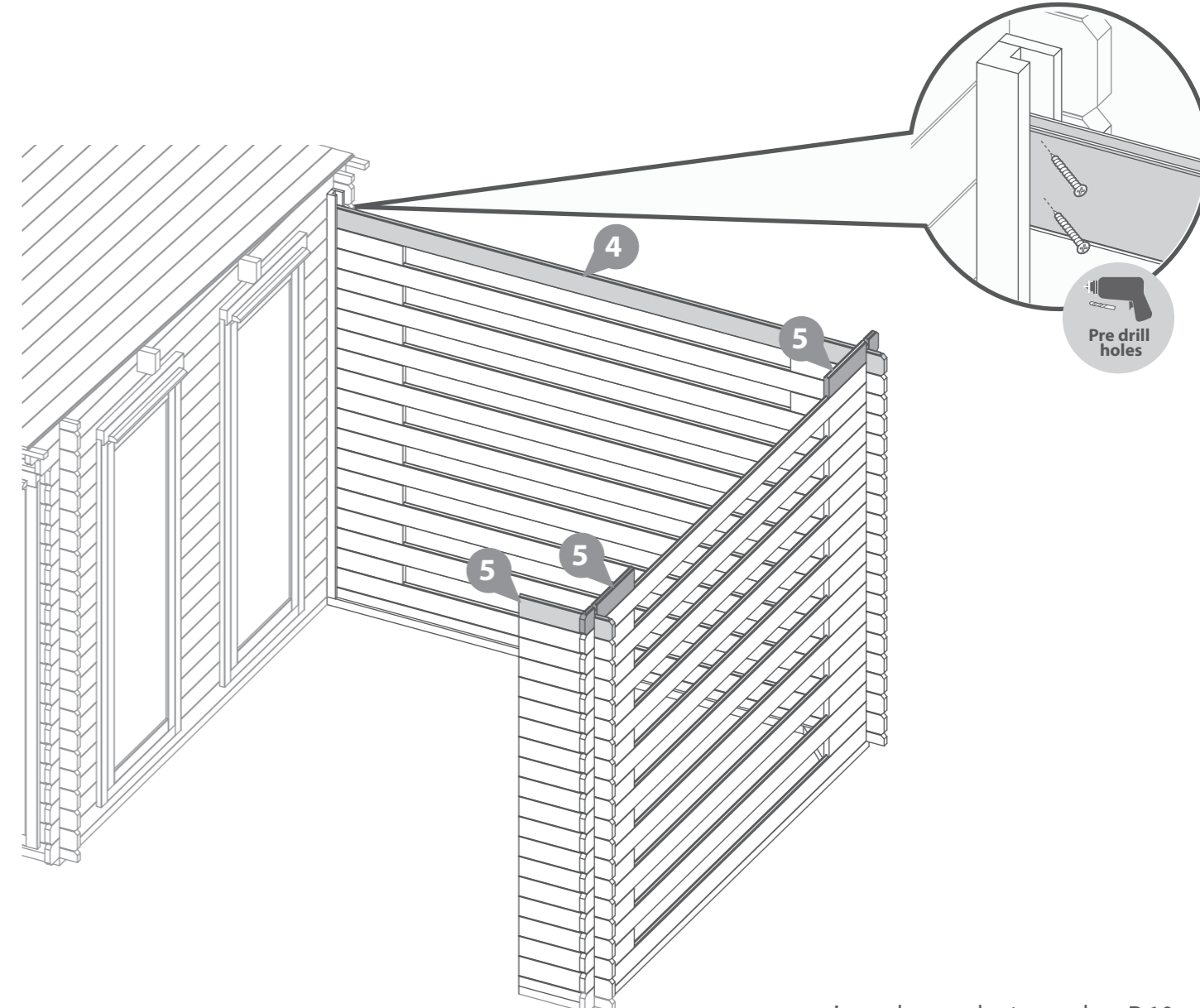

Step 11

Parts Needed - No. 5 QTY 2
No. 6 QTY 1
No. 10 QTY 1

Following the method shown in the illustration, lay the boards (**No. 5 & 6**) and Gable (**No. 10**) onto the patio to create your next level, ensuring that the back log board (**No.6**) sits inside the 'U' channel.

**Ensure that the boards are level and flush with each other as you lay each one.*

Secure the back top board (**No.6**) by screwing through the Log board at an angle into the 'U' channel, using 2x50mm screws.

2x50mm screws.

Important: Pre-drill before fixing screws.

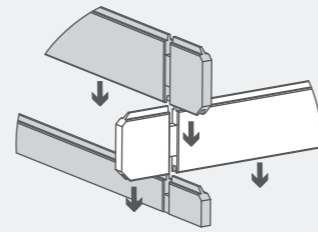

Rubber Mallet.



Drill / Pre drill.



50mm screw

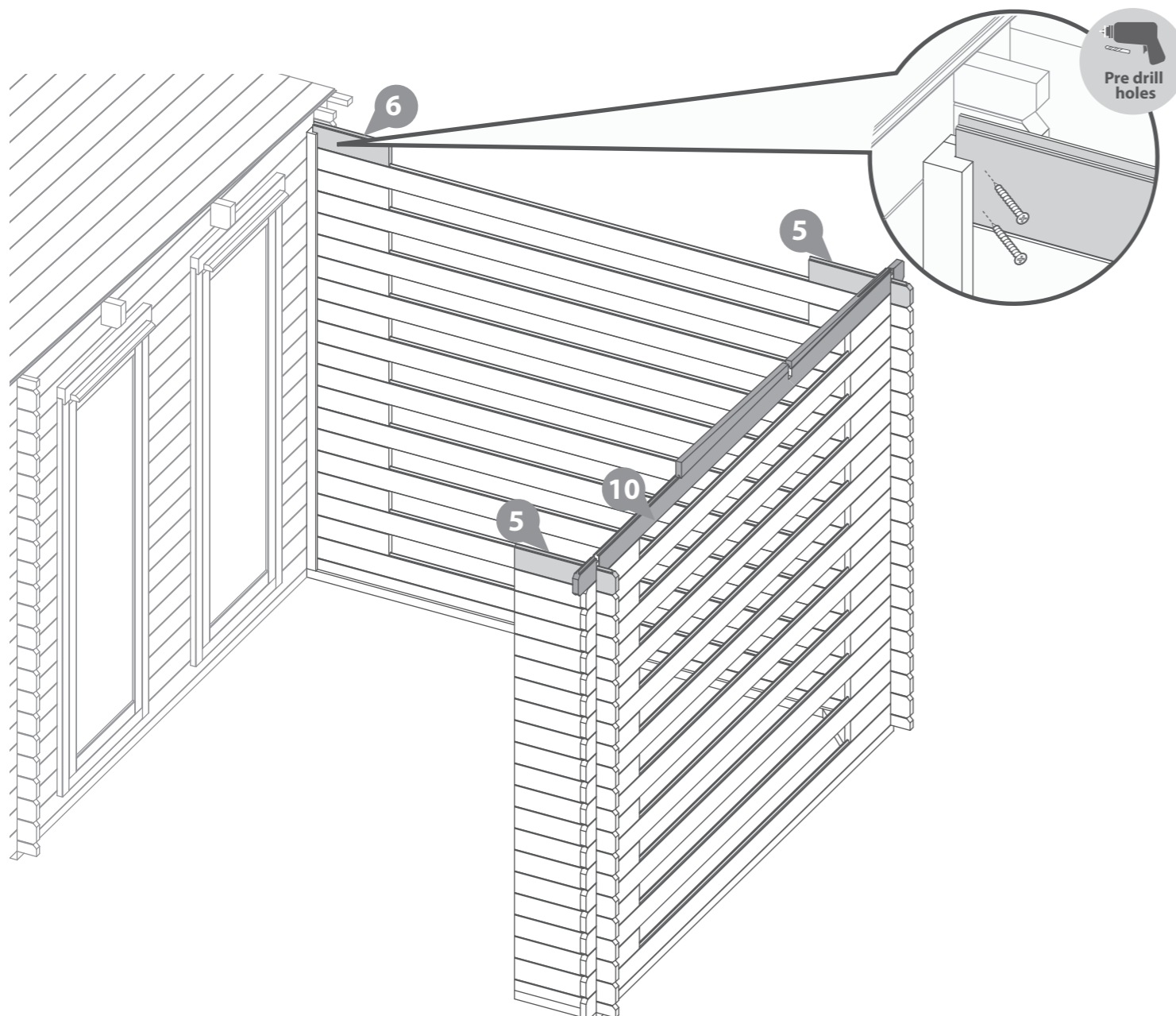

Step 12

Parts Needed - No. 7 QTY 1
No. 8 QTY 1
No. 11 QTY 1

Following the method shown in the illustration, lay the board (**No. 7**), finisher board (**No.8**) and Gable Point (**No. 11**) to create your next level. The back board (**No.8**) will sit above the top of the 'U' Channel. This allows for the timbers natural movement over time.

Ensure the front board (**No. 7**) sits in front of the log cabins front log boards, and the end of the board is flush to the main cabin, as shown.

**Ensure that the boards are level and flush with each other as you lay each one.*

Secure the front top board (**No.7**) by screwing through the Log board into the Log Cabin's log board behind, using 2x50mm screws.

Fix each board to the board below by screwing through the notches using 1x70mm screw per notch, as shown.

2x50mm screws.

2x70mm screws.

Important: Pre-drill before fixing screws.

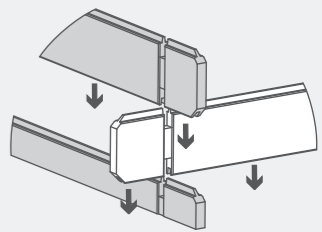

Rubber Mallet.



Drill / Pre drill.

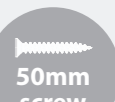

50mm screw

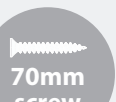

70mm screw

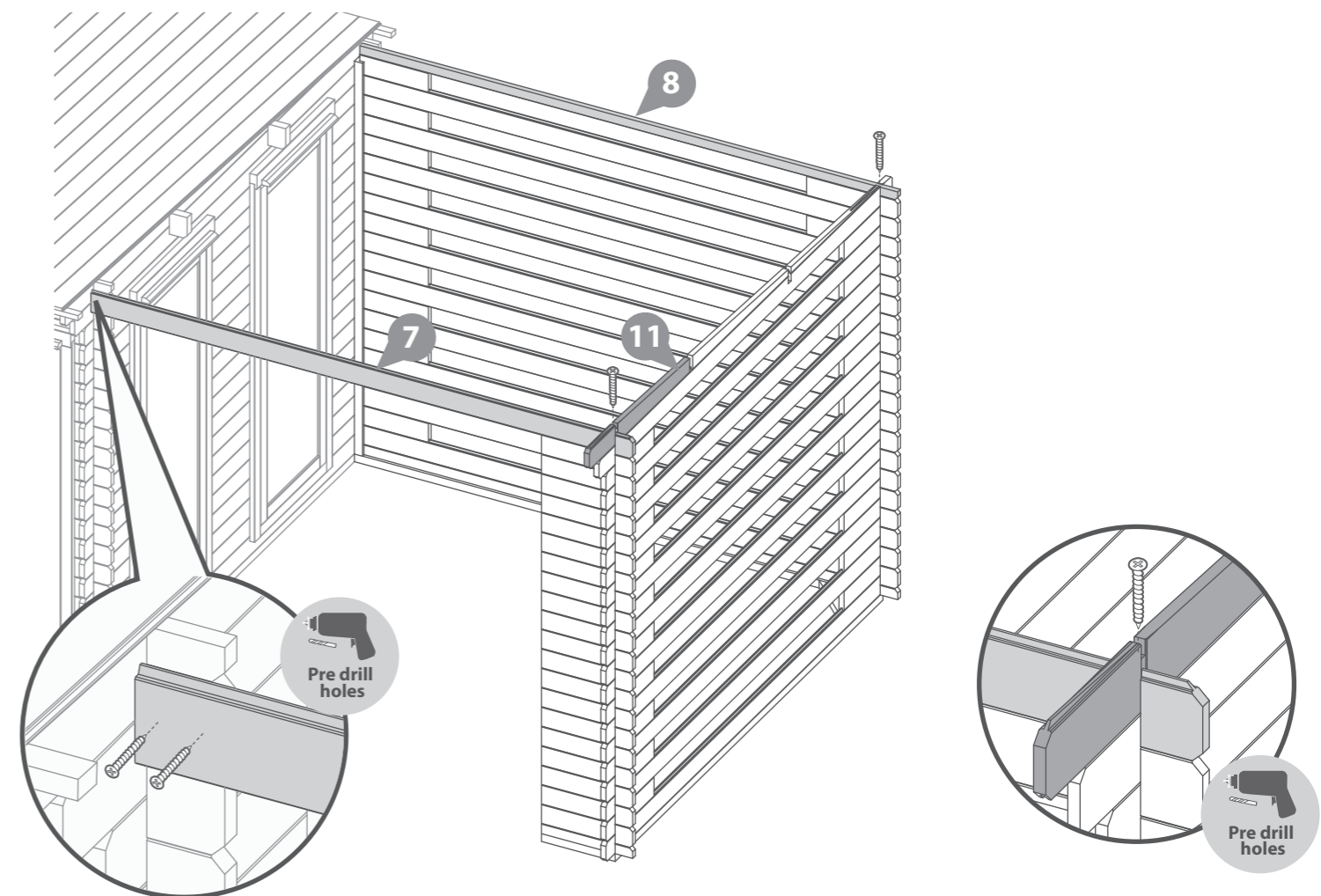

Step 13
Parts Needed - No. 9 QTY 1

Following the method shown in the illustration, lay the final finisher board (No.9) onto the patio.

**Ensure that the boards are level and flush with each other as you lay each one.*

Fix the Finisher Board (No. 9) to the Gable below by screwing through the notch using 1x70mm screw, as shown.

1x70mm screws.
Important: Pre-drill before fixing screws.

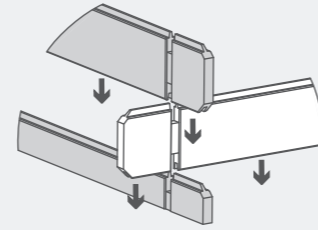

Rubber Mallet.



Drill / Pre drill.

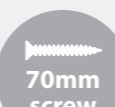

70mm screw

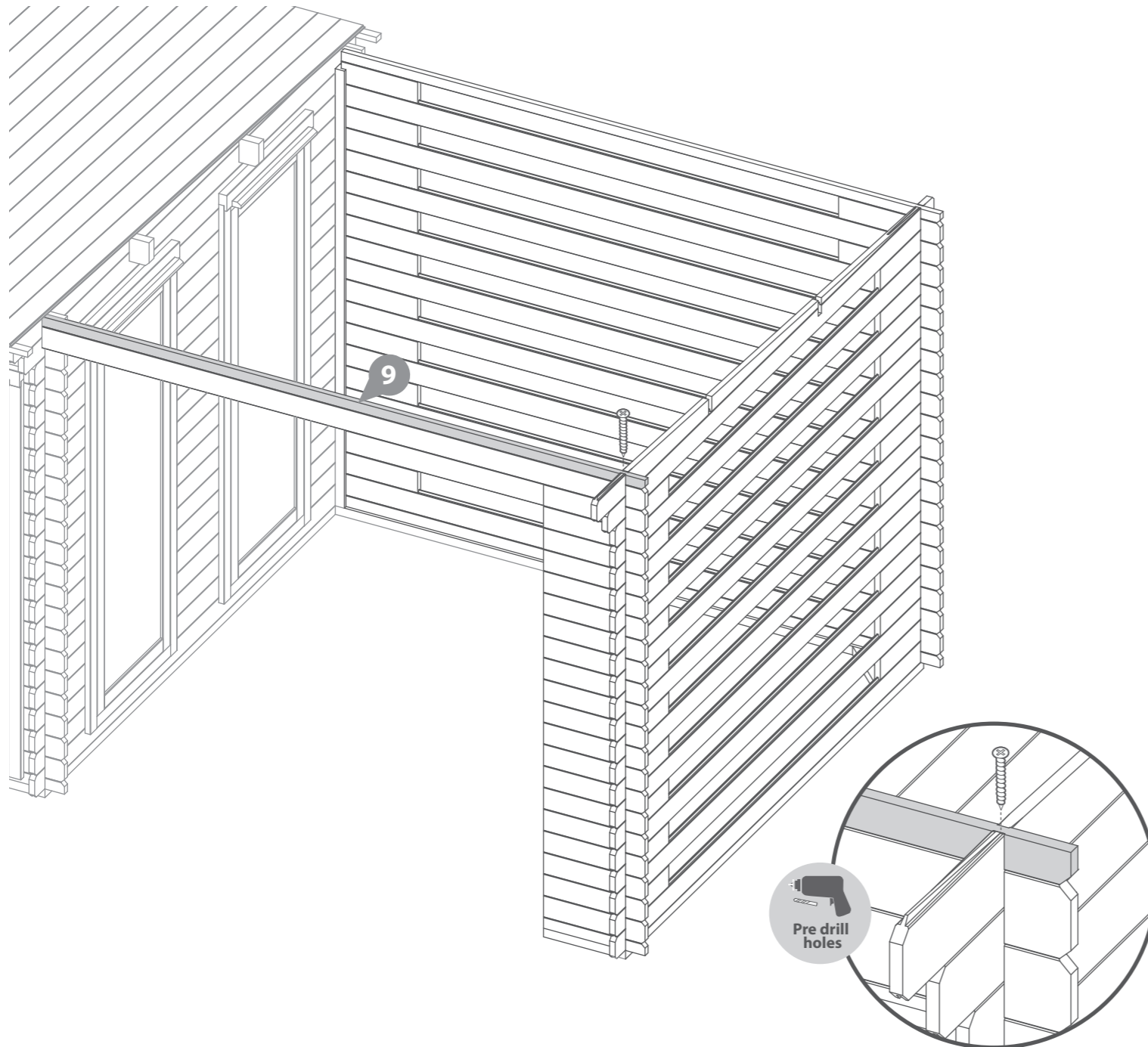

Step 14
Parts Needed - No. 16 QTY 2

a Align the Roof Purlins (No. 16) into the cut out slots on the Gable, ensuring they interlock.

Note: Use a mallet and a scrap piece of wood to gently fix the purlins into position.

b Secure the roof purlins at each end by screwing through the purlins into the gable below, and through the purlin into the Log cabins purlins, as illustrated, using 2x70mm screws per end.

**Please note: The Log cabin used in the step is for illustrative purposes only and may differ from your choice in building, however the process of fitting the purlins is the same.*

8x70mm Screws
Important: Pre-drill before fixing screws.



Rubber Mallet.



Drill / Pre drill.

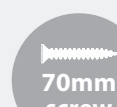

70mm screw

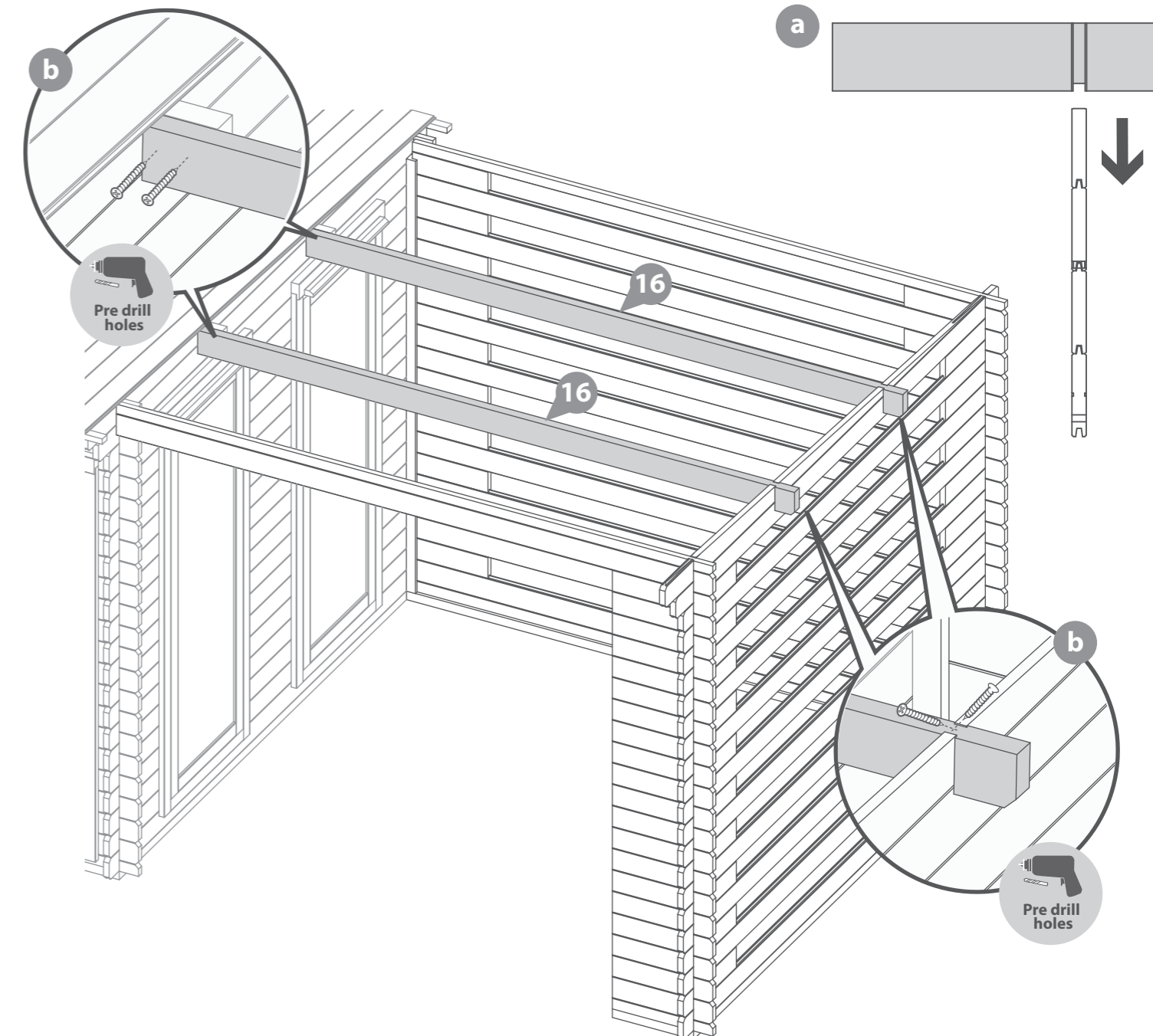

Step 15

Parts needed - No. 17 QTY 27

No. 24 QTY 5

- a** Place the remaining roof board from the Log Cabin onto the roof. Fix in place to the Purlins, front and back of the cabin, using 4x40mm screws.
- b** Place the first roof board (**No. 17**) onto the shed add on, making sure the board interlocks with the last placed board from the cabin, and is flush and level.

Ensure there is an even amount of overhang between the log boards and roof board at the front and back of the cabin. Once in position, fix to the purlins, front and back of the shed add on using 4x40mm screws.

To ensure the roof boards are not laid too close together, use the spacers (**No. 24**) provided to create a 2mm gap. Adjusting the spacing between the boards allows the wood to swell in damp weather.

Continue to add roof boards onto the roof. Once in position fix to the purlin, front and back of the log cabin using 4x40mm screws per roof board.

You have been issued with 27 roof boards, but you may only need to use 26.

- c** The last board will overhang past the end of the Purlins. Using a straight edge and a pencil, mark out a line as a guide.

Saw along the pencil mark and remove the excess. Place the cut down board's back onto the roof and secure into place using 4x40mm screws per board.

***Please note:** The Log cabin used in the step is for illustrative purposes only and may differ from your choice in building, however the process of fitting the roof boards is the same.

108x40mm Screws

Important: Pre-drill before fixing screws.

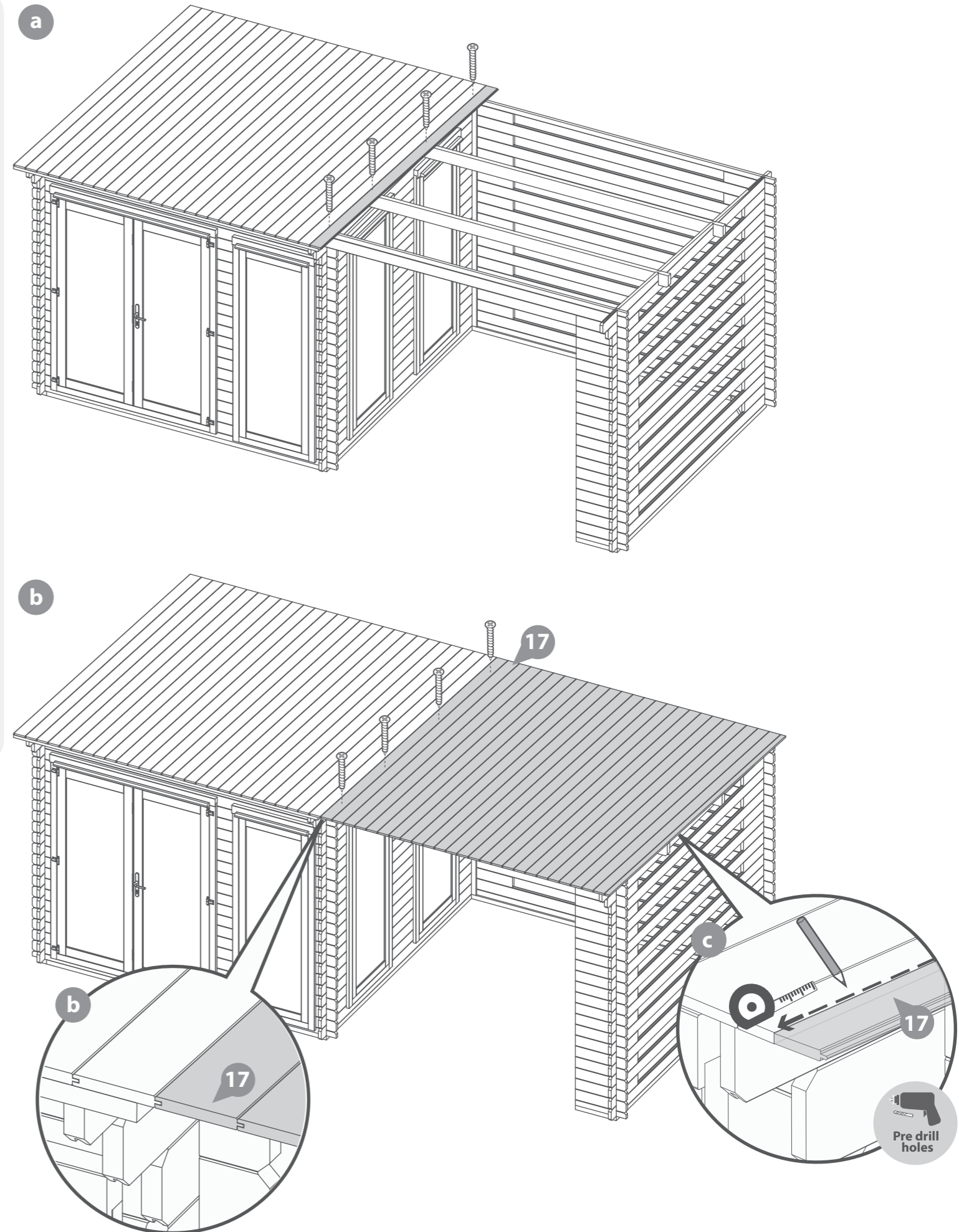

Step 16
Parts Needed - No. 18 QTY 2

Ensuring the roof boards are flush and level, locate the Eaves Frames (No. 18) to the underside of the roof boards at the front and back of the patio. Secure in place using 6x30mm screws per frame, as shown in the illustration

12x30mm Screws
Important: Pre-drill before fixing screws.

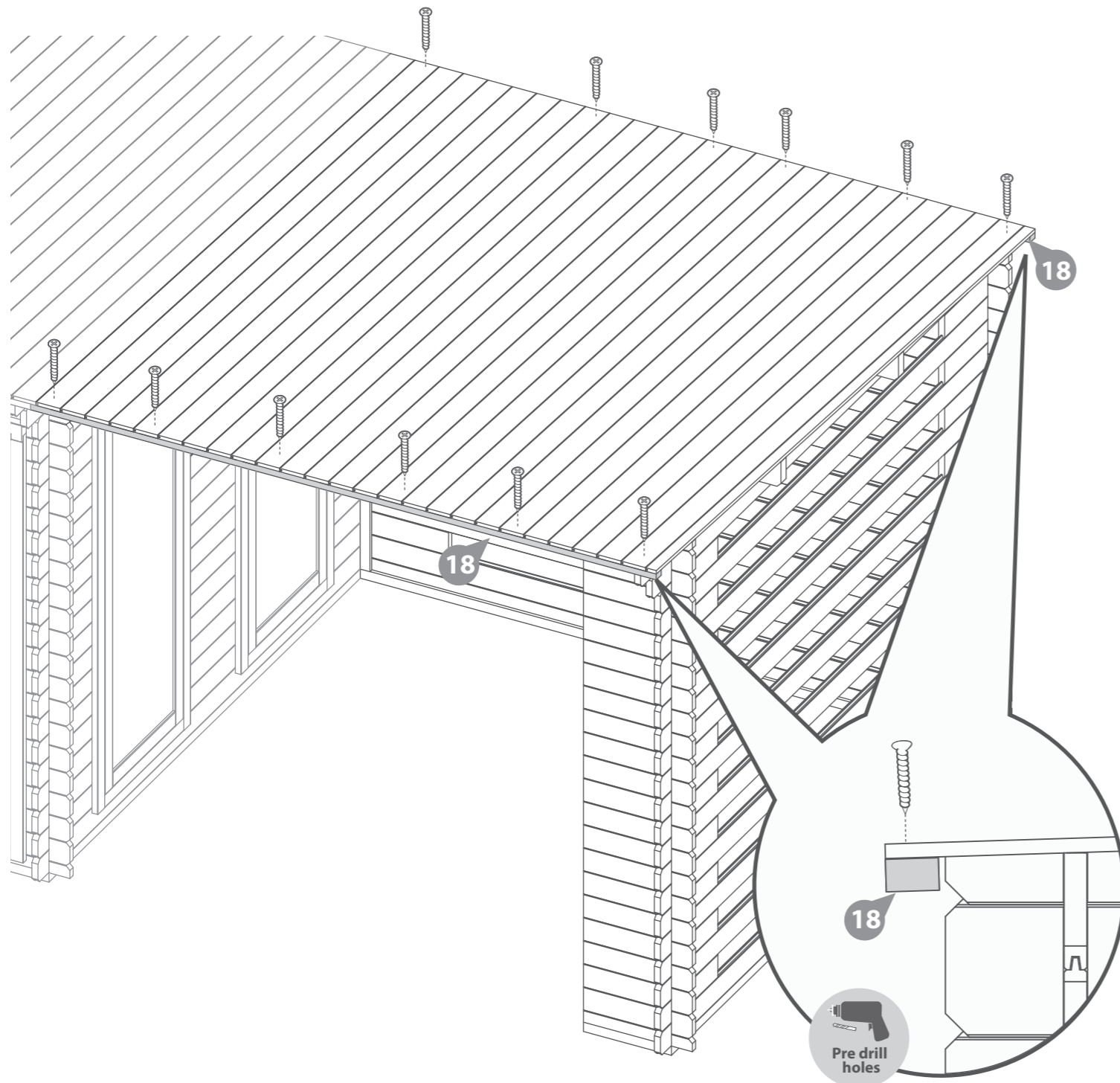

Step 17
Parts needed - No. 20 QTY 3

Inside the building, place the closure trim (No. 20) against the boarding and align with the roof as shown in the illustration.

***Measure and cut the closure trims to fit the internal space.**

Once in position fix each trim into place by pre drilling a pilot hole and using 6x30mm screws per trim, equally spacing them along the face of the board.

18x30mm Screws
Important: Pre-drill before fixing screws.

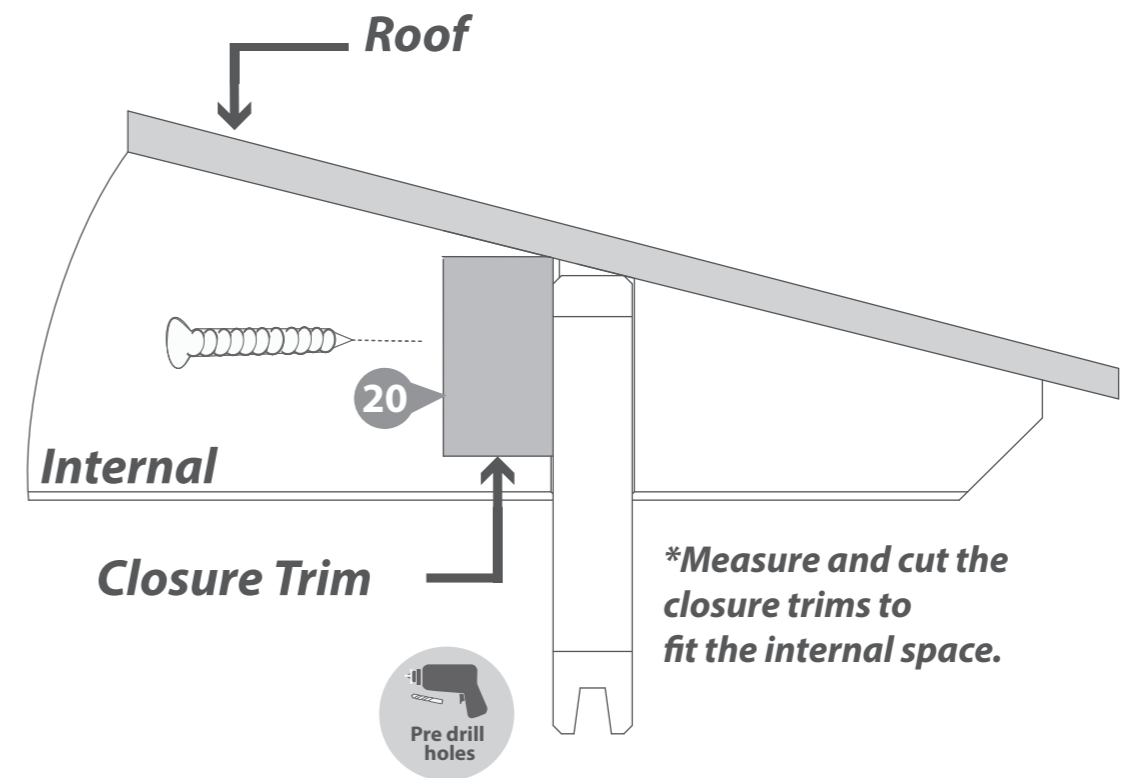
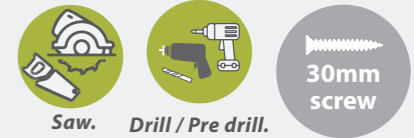

Step 18

- Parts Needed - No. 25**
No. 26
No. 28 QTY 1

a Cut the Sand Capping Felt (**No.25**) into one sheet measuring:
3x3 Cabin + patio area = 6000mm (L) x 300mm (W)
4x3 Cabin + patio area = 7000mm (L) x 300mm (W)

Cut the Sand Felt (**No.26**) into four sheets measuring:
3x3 Cabin + patio area = 6000mm (L) x 1000mm (W)
4x3 Cabin + patio area = 7000mm (L) x 1000mm (W)

Lay the sheets onto the roof in the order shown, starting with the Capping Felt (**No.25**) as the first sheet laid, then the remaining four sheets (**No.26**), as shown.

Ensure the sheets overhang each side by 50mm and overlap each other by 100mm.

There may be a larger overhang around the building than suggested, if so, excess felt can be cut off from around the building after fitting is complete.

b To ensure a complete bond between the sheets, apply the Butyl (**No.28**) between each overlapping layer, as shown in the image. Ensure to apply the Butyl using a sealant application gun and in a 'wiggly' line for the best finish. Once applied, compact the layers to seal.

At each corner, fold the felt over each other so they sit on the front and backs of the building, as shown.

Secure the felt in place by hammering felt tacks into the overlapping layers, the front, back and sides of the building at 100mm intervals, as shown.

***Please note:** The Log cabin used in the step is for illustrative purposes only and may differ from your choice in building, however the process of fitting the felt is the same.

300 x Felt Tacks

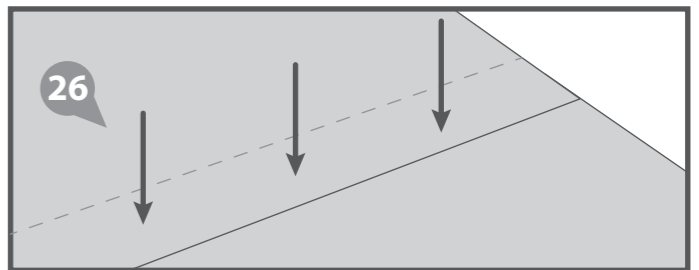
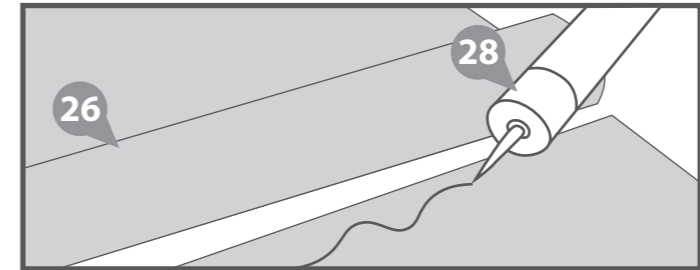
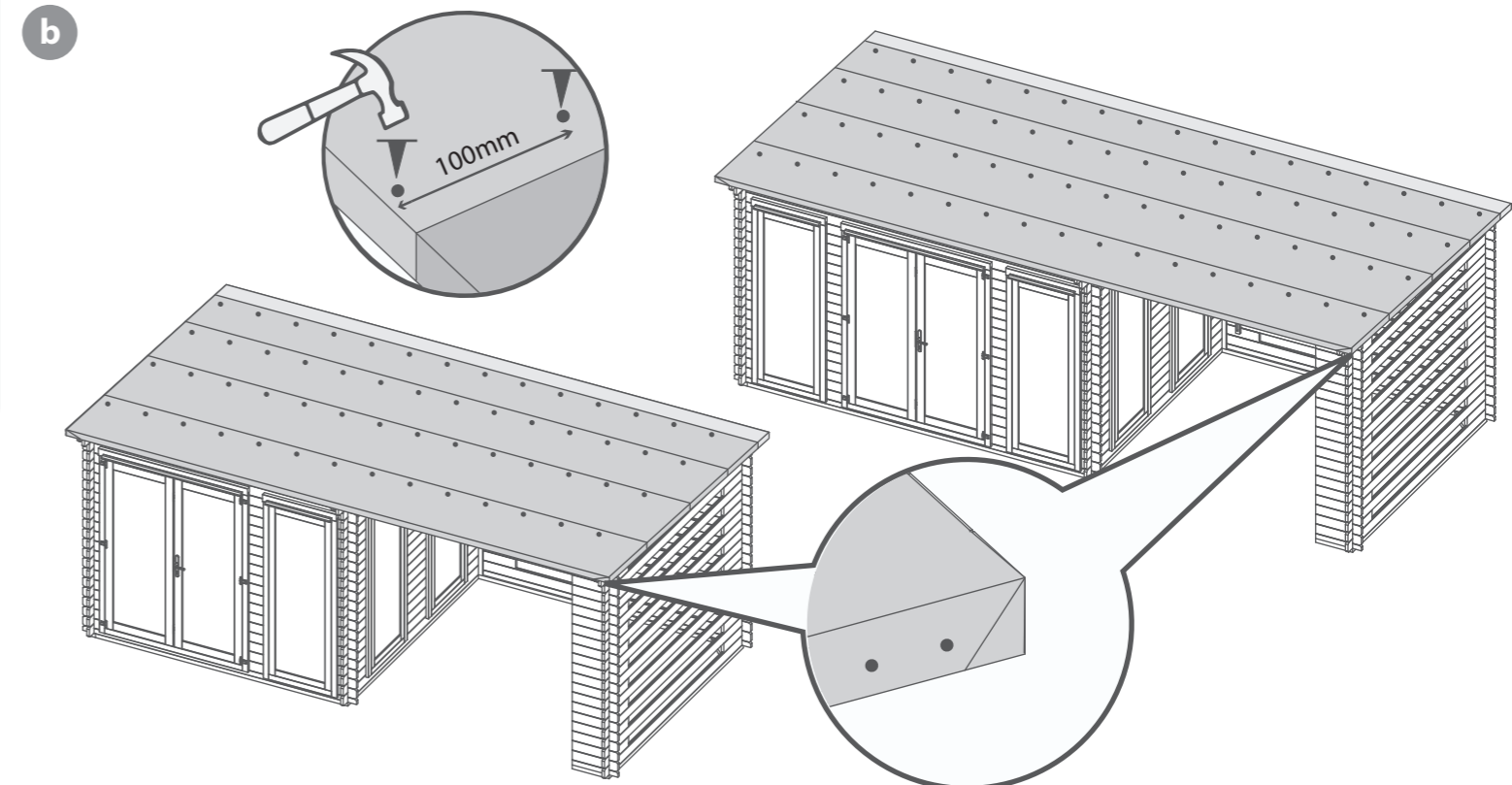
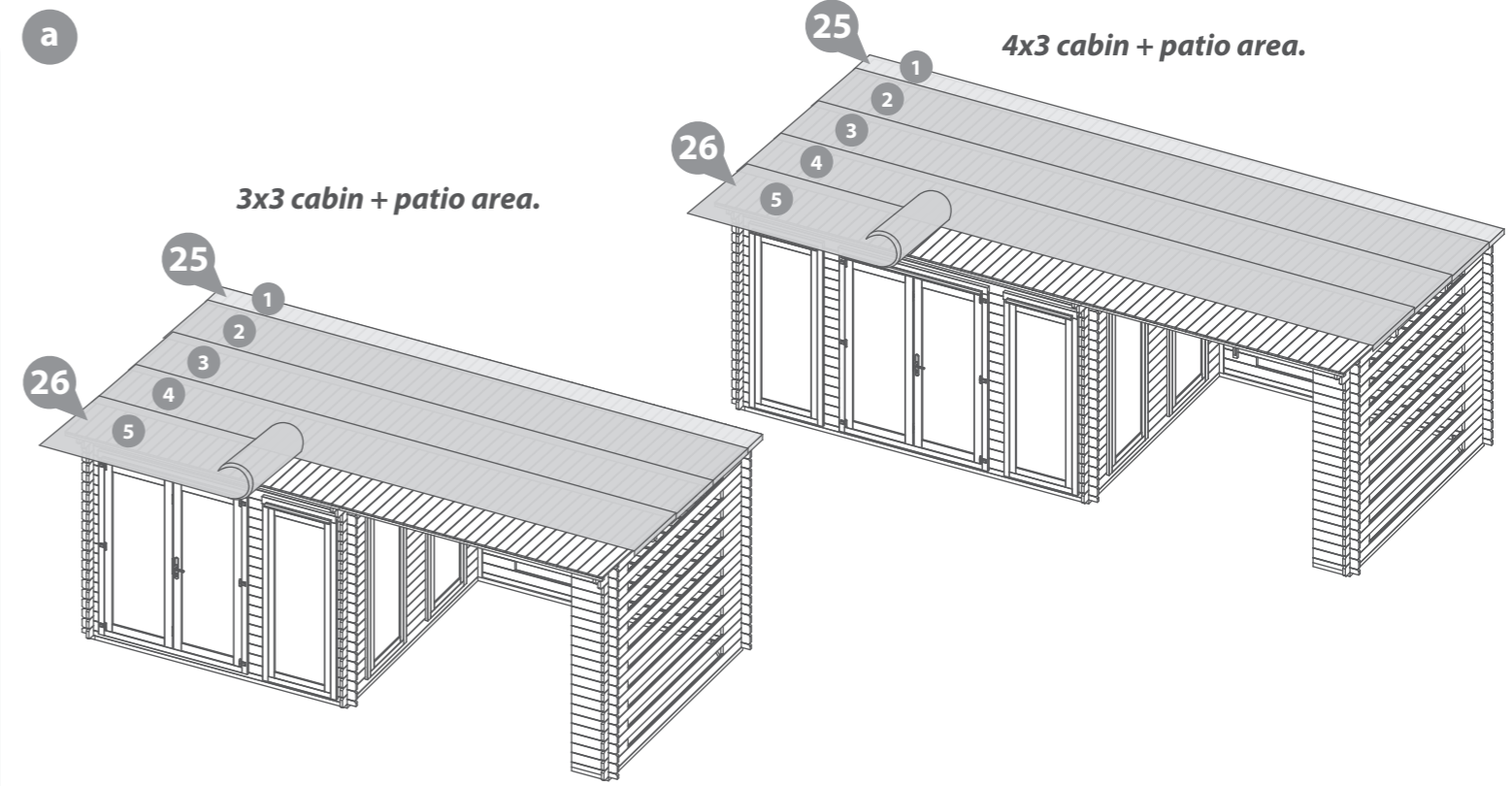
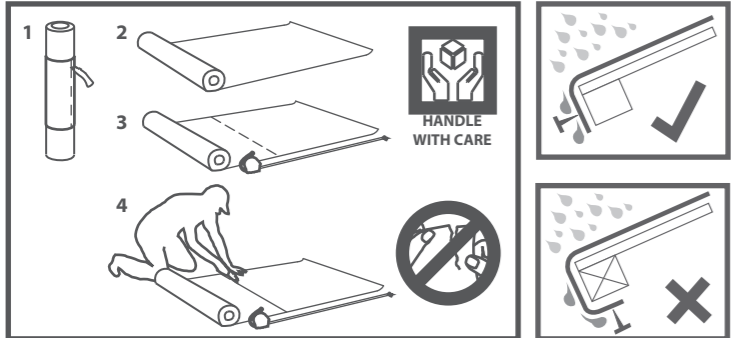
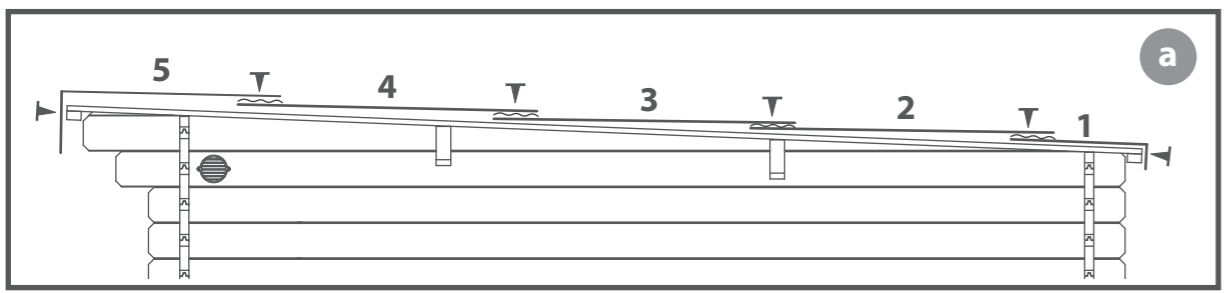

Step 19

Parts Needed - No. 27

No. 28 QTY 1

- a** Cut the Green Felt (No.27) into four sheets measuring:
3x3 Cabin + patio area = 6000mm (L) x 1000mm (W)
4x3 Cabin + patio area = 7000mm (L) x 1000mm (W)

Lay the sheets onto the roof in the order shown. Ensure the sheets overhang each side by 50mm and overlap each other by 100mm.

****Make sure that where the Green felt layers overlap is offset to the previously laid Sand felt, as shown in the diagram. This will ensure the felt can be secured correctly and allows water to drain off efficiently.****

There may be a larger overhang around the building than suggested, if so, excess felt can be cut off from around the building after fitting is complete.

- b** To ensure a complete bond between the sheets, apply the Butyl (No.28) between each overlapping layer, as shown in the image. Ensure to apply the Butyl using a sealant application gun and in a 'wiggly' line for the best finish. Once applied, compact the layers to seal.

At each corner, fold the felt over each other so they sit on the sides of the building, as shown. Ensure these corners sit on the opposite sides to the sand felt, as suggested.

Secure the felt in place by hammering felt tacks into the overlapping layers, the front, back and sides of the building at 100mm intervals, as shown. Ensure to stagger the tacks on the sides, front and back to avoid colliding with the layers below.

***Please note:** The Log cabin used in the step is for illustrative purposes only and may differ from your choice in building, however the process of fitting the felt is the same.

300 x Felt Tacks

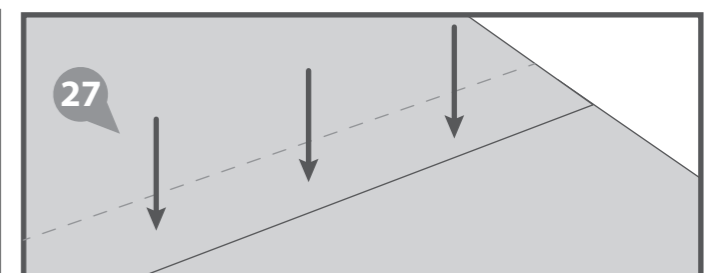
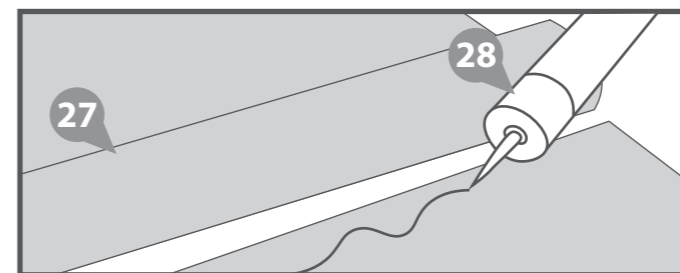
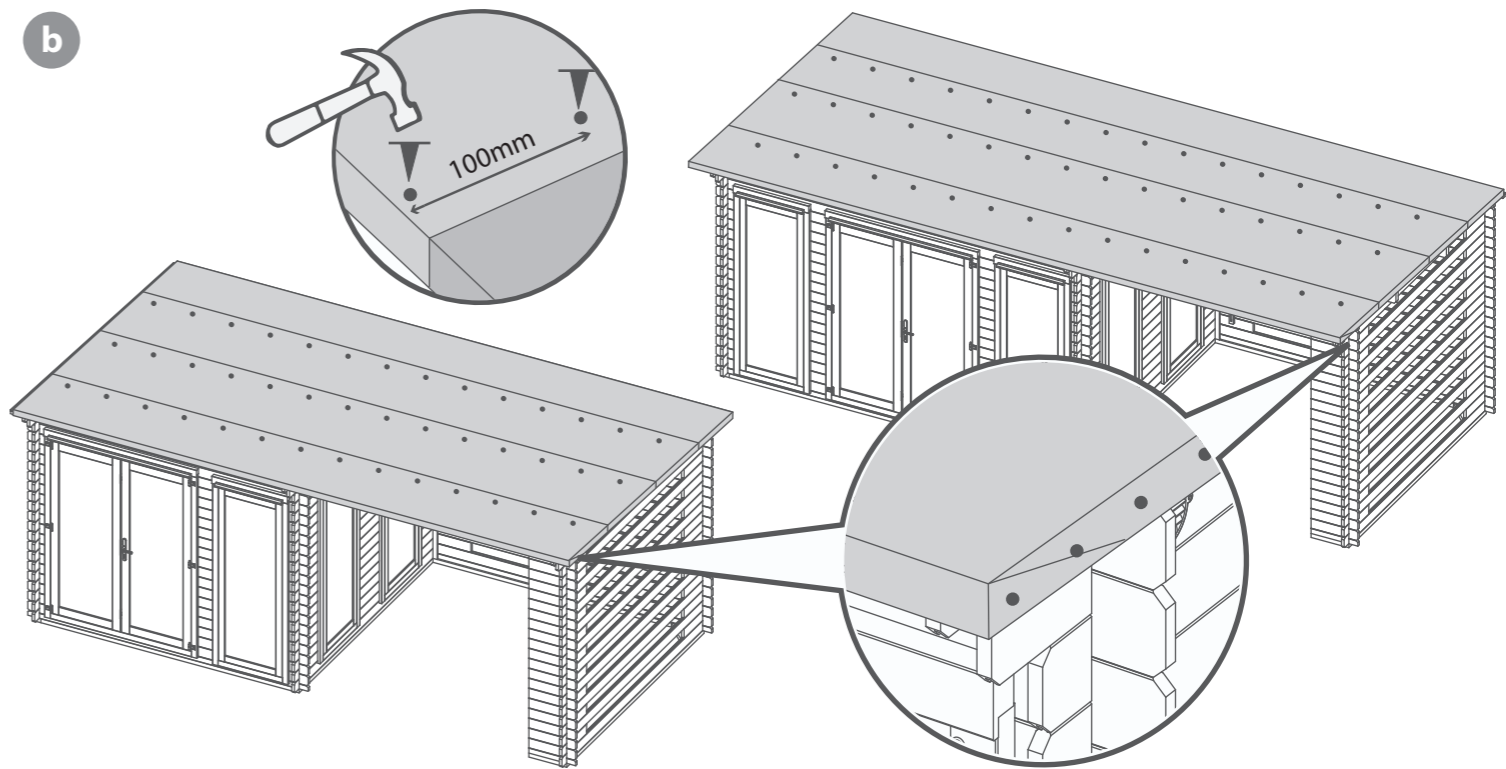
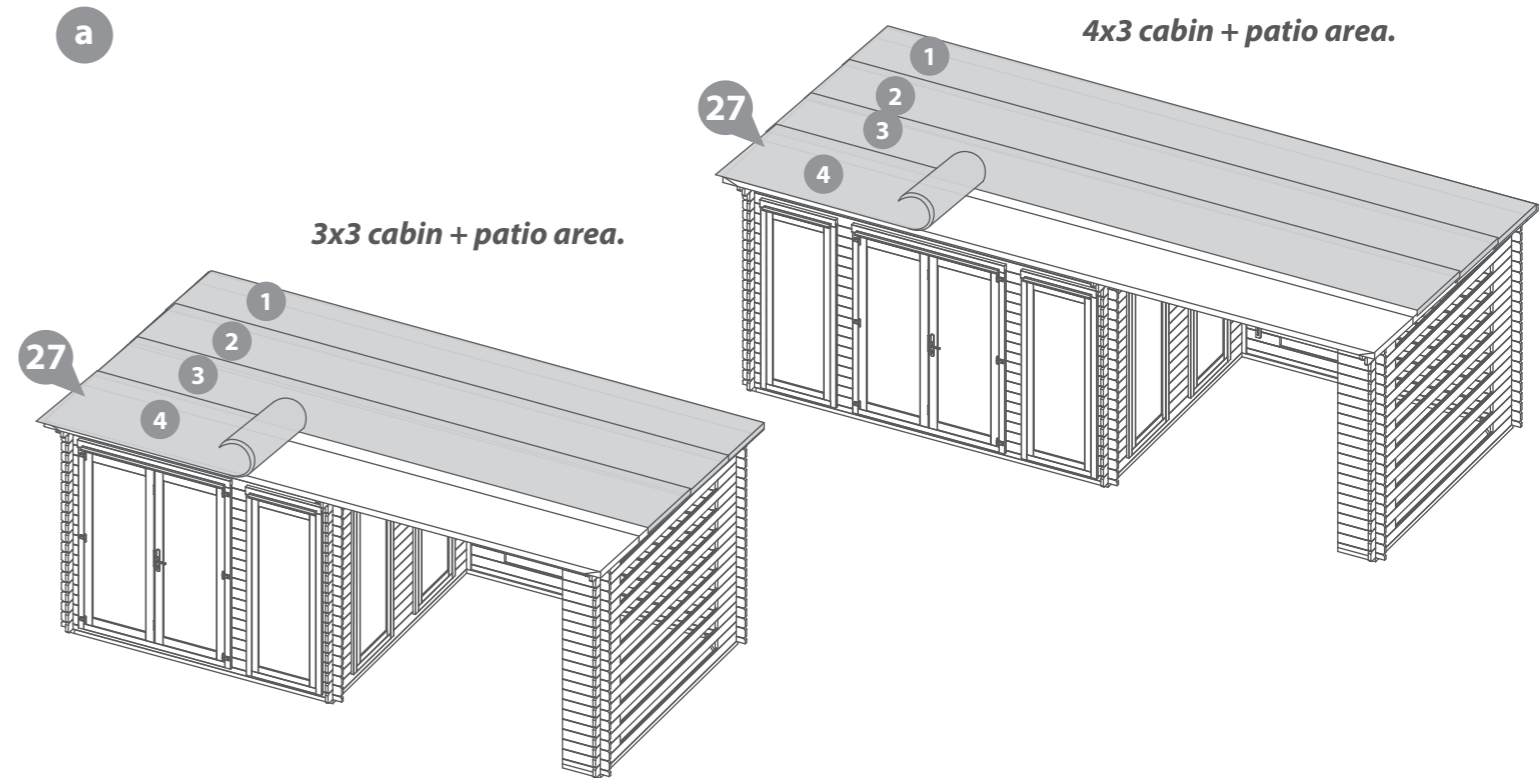
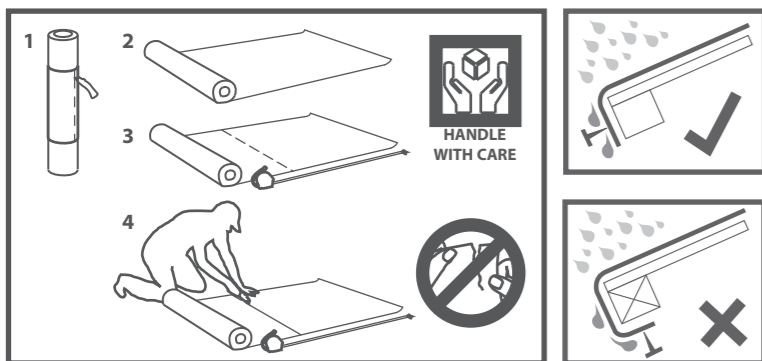
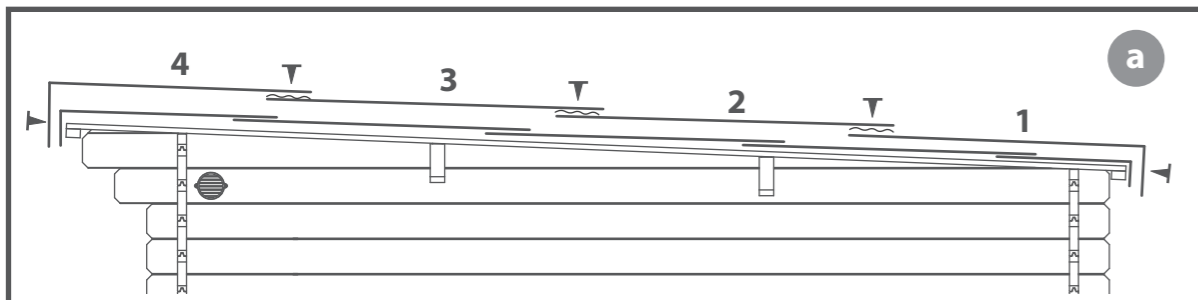

Step 20

Parts Needed - No. 19 QTY 2

- a** Attach the Patio's Fascias (**No. 19**) and the remaining Cabin Fascias to the front and back of the log cabin and Patio (*ensuring to trap the felt in-between the fascias*) securing in place by screwing through the Fascia into the Eaves Frames using 4x40mm screws per Fascia.

Once in place, mark the excess Fascia with a pencil and trim the Fascias to follow the shape of the building, as shown in the illustration.

- b** Locate the remaining Cabin Fascias to the sides of the log cabin and Patio (*ensuring to trap the felt in-between the fascia*) and secure in place using 6x40mm screws per fascia, screwing through the Fascia into the Purlins, eaves frame or log board behind.

Once in place, repeat the above method to trim the fascias to follow the shape of the building.

Ensure the fascias at the back of the log cabin sit level or lower than the felt to allow water to run off.

***Please note:** The Log cabin used in the step is for illustrative purposes only and may differ from your choice in building, however the process of fitting the fascias is the same.

8x40mm Screws

Important: Pre-drill before fixing screws.

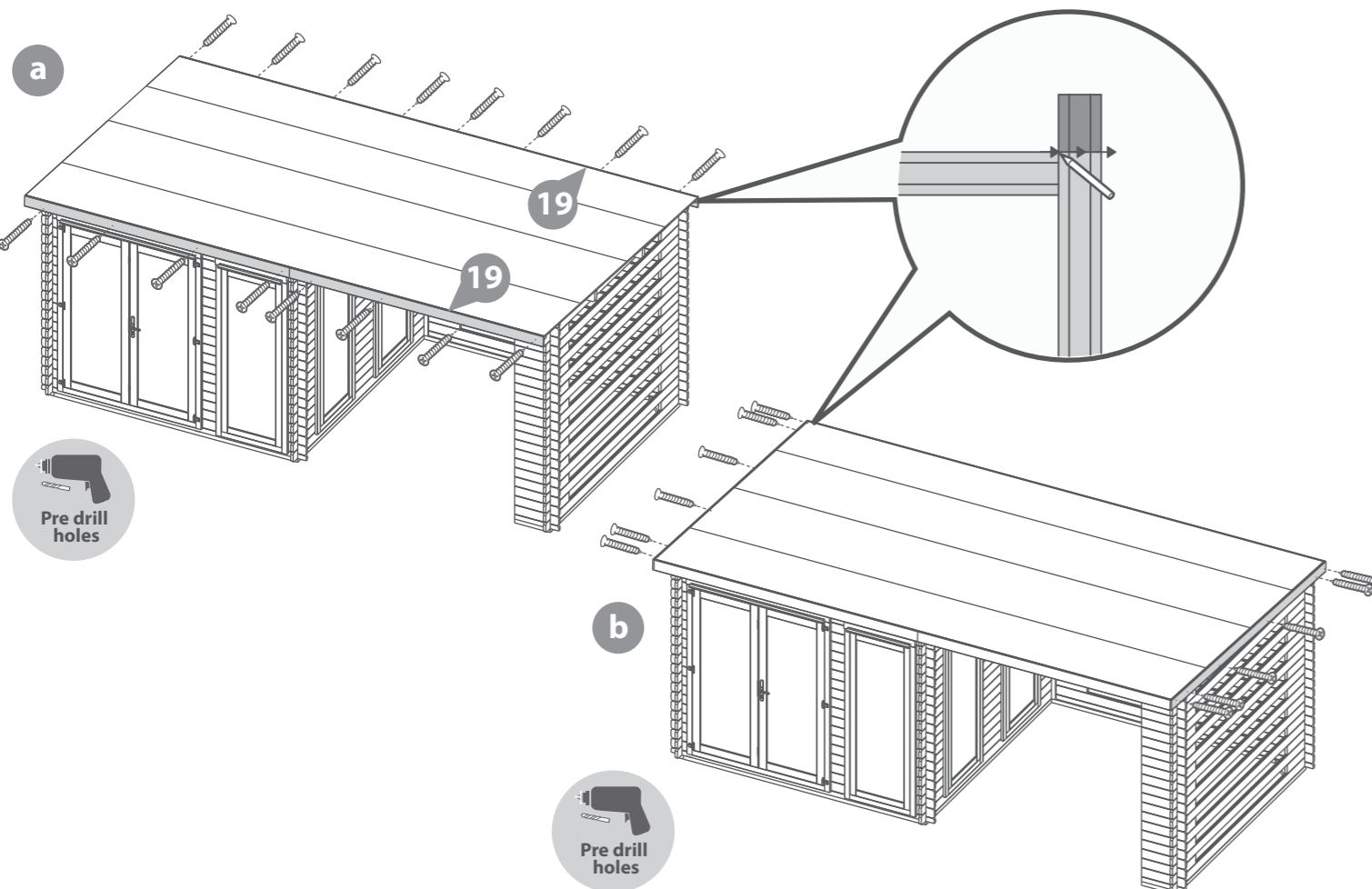

Step 21

Parts needed - No. 21 QTY 5

Arrange the storm braces (**No.21**) around the building (*internally*), placing two storm braces per wall.

***Ensure the storm braces are secured at the highest point possible on each side.**

Fix in place using 2x70mm bolts per brace, making sure the washer & nut are tightened from the outside of the building.

The storm braces will need to be altered during the buildings life as the moisture content within the log boards changes. The boards will expand during periods of high moisture (Winter) and shrink during periods of low moisture (Summer.)

****Storm braces are required to be adjusted during changes in humidity to allow the building to expand and contract. To do this, periodically loosen the bolts, adjust the storm brace position and re-tighten.**

*****Important: Ensure each bolt is tightened using a washer so as not to damage the log boards.**

***Please note:** The Log cabin used in the step is for illustrative purposes only and may differ from your choice in building, however the process of fitting the Storm Braces is the same.

10x70mm Bolt Sets

Important: Pre-drill before fixing screws.

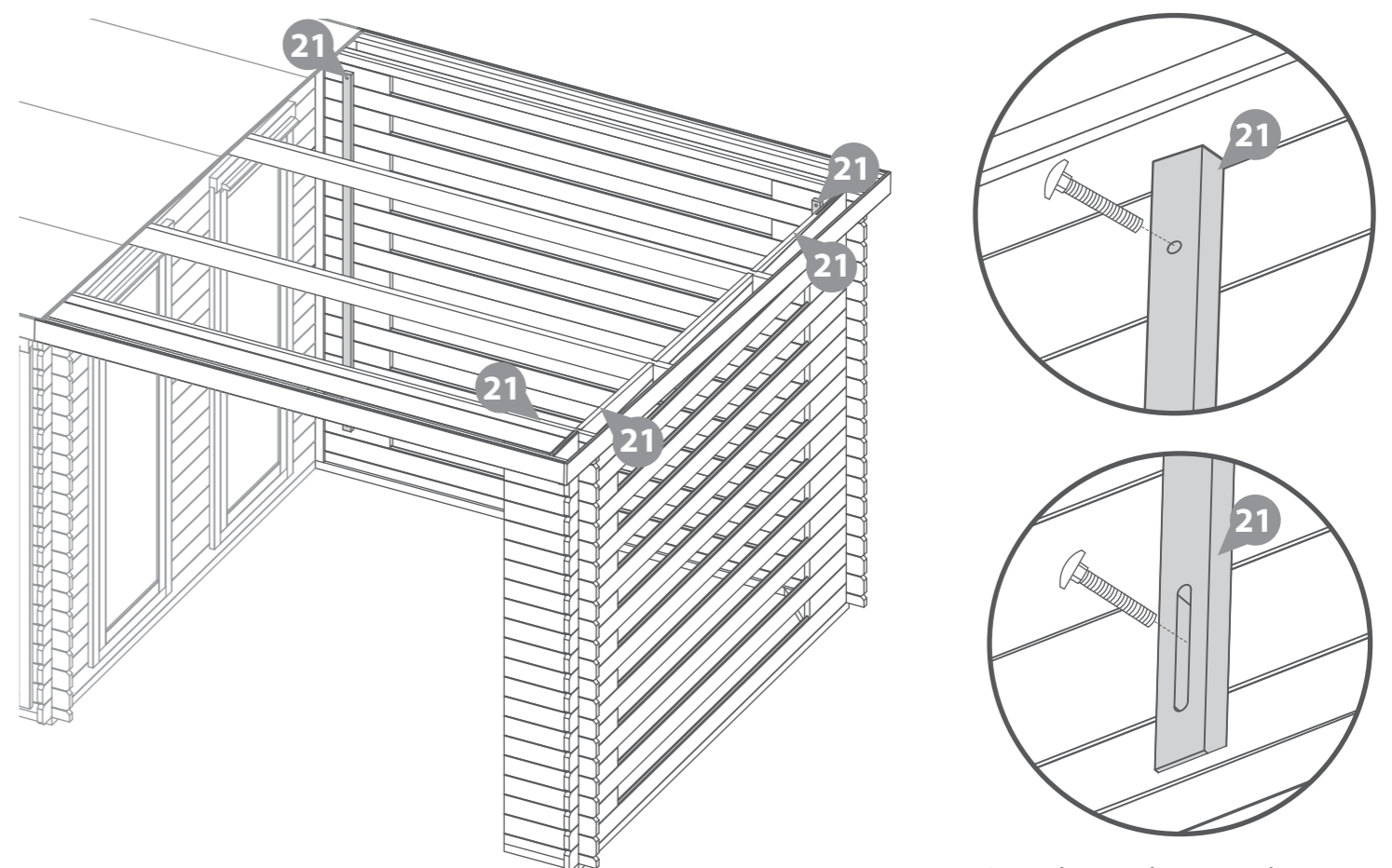
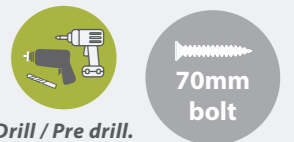

Step 22

Once constructed, apply a preserving and a waterproofing treatment to your log cabin as soon as possible. This will help to protect your building and prevent decay.

***Please note:** The Log cabin used in the step is for illustrative purposes only and may differ from your choice in building, however the process of treating the building is the same.

See page 19 for a full guide and instructions.



Apply treatment.



Timber preservative treatment



Treatment mixing stick.



Paintbrush/sprayer/roller.

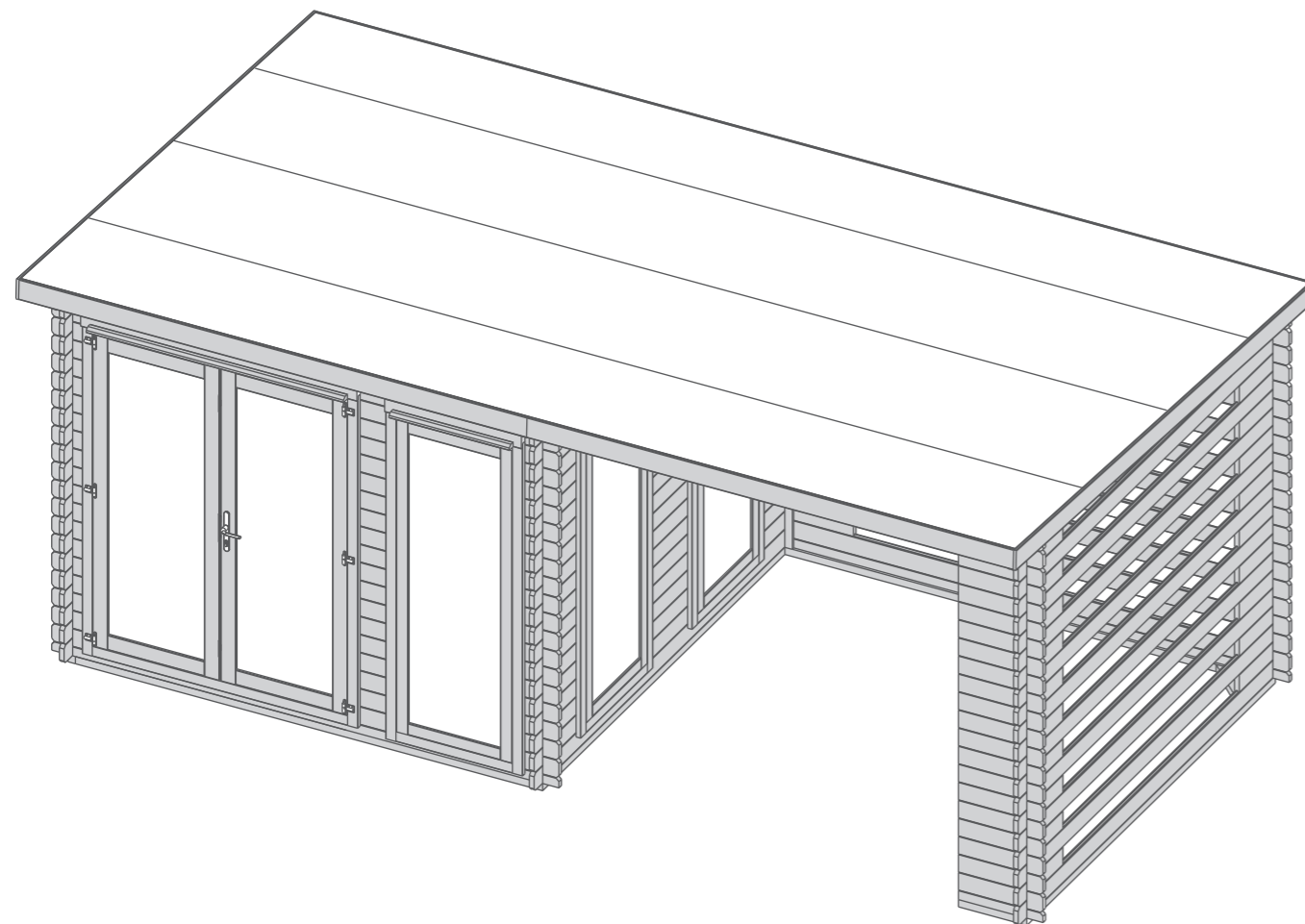

LEAVE US A REVIEW...



Want to share your experience with us?
Leave us a review on Feefo, TrustPilot or Google.

Your reviews help other people find and trust our business, as well as helping to play an important role in our growth and improvement!

TREATING YOUR GARDEN BUILDING

Preservation of wood that's outdoors is vital. A little early care will help protect your garden building, improve its appearance and ensure maximum longevity. Insects, moisture, salt, and changing weather can have dramatic effects on the stability and appearance of your garden building. Once your building is installed, you've checked it over and you're happy with it, you can take a few basic precautions to prepare it for the elements. Treating your garden building helps prevent decay and, by repelling water, discourages the growth of moulds and fungi that could jeopardise the structural integrity of the wood.

Dip Treated buildings - Require a preservative treatment to protect against rot and decay and a waterproof treatment to prevent water ingress
Pressure Treated buildings - Require a waterproof treatment to prevent water ingress
Log Cabins/Insulated Garden Rooms - Are supplied untreated and require a preservative and waterproofing treatment.



ANY QUESTIONS?

Scan the QR code to contact us via our customer portal.

To apply a preservative and water proofing treatment (pressure treated products do not require a preserver), follow the manufacturer's instructions but in principle, stick to the following steps:

- ✓ Weather permitting, ensure to treat your garden building within 14 days of installation.
- ✓ Wear latex or rubber gloves, eye protection and (if spraying) a mask.
- ✓ Prepare the wood, by sanding down any ridges or inconsistencies in the wood, smoothing out knots and end-cuts.
- ✓ Choose a dry day to treat your garden building. If you're spraying rather than brushing paint on, avoid a windy day.
- ✓ Be sure you can safely reach all the sections you need to paint - and if you need a ladder, make sure it's safely positioned before climbing. Lay dust sheets around to avoid paint splatters on your base or surrounding plants.

- ✓ Tape around windowpanes to avoid smears when you're painting the frames.
- ✓ Keep pets and small children out of the way. The last thing you want is to have fur on your garden building paint, or little painted footprints all over your garden and home.
- ✓ Fill any gaps in the building's body with caulk or wood filler to prevent water and draughts getting in. Silicone based caulk is flexible and will move with the timber when temperature and humidity change. Allow to dry completely before treating. A handy tip for finding gaps is to go into your garden building and look for light leaking through joins and frames. If light gets in, then so will water.
- ✓ Liberally apply at least two coats of the treatment products with a brush or spray, taking care to allow the first coat to completely dry before applying the second.
- ✓ Make sure the solution permeates the whole of the surface area, especially around natural cracks, end cuts and nail/screw holes.



APPLY WOOD TREATMENT
IMMEDIATELY
AFTER ASSEMBLY

PLEASE SCAN HERE TO
SEE TREATMENT VIDEO:



1 Perimeter

Check around the perimeter of your product to ensure there are not trees or plants that are in contact with or overhanging the building. This can affect airflow and overhanging trees, or branches can damage the roof, it is advised to keep plants at a distance.

2 Repair

Inspect the interior and exterior of the product to look for splits, cracks, and holes. Although this is a natural occurrence it can be prevented. A wood filler can be used to close the splits, cracks, and holes.

3 Roof

Check your roof regularly for tears, splits, damaged wood and fallen debris. If you notice any of this immediate repair is critical.

4 Doors & Windows

Expansion and contraction can cause doors and windows to stick or become difficult to open. Small adjustments to the hinge position can be made to the doors and windows to allow free movement.

5 Oil

Hinges can seize up over time, apply lubricant to the hinges and locks annually.

6 Screws & Bolts

It is advised to check all screws and bolts and tighten any loose you might find. For log cabins specifically the storm braces will require loosening. During humidity and temperature changes (seasons) to allow expansion and contraction to prevent gaping, twisting, popping, and warping.

7 Wash

At least once a year, give the outside of you building a good wash, to remove cobwebs, leaves, or any other dirt that may accumulate on the exterior.

8 Airing

Airing your product regularly prevents the build up of condensation which can cause the timber to warp, bow, boards to pop, distortion, rot and mould. Condensation can build up over time or daily, it is caused by a rise and fall in temperature.

Excessive moisture levels within your building can cause water to collect on the roofs, walls and floors internally. Leaving doors and windows open regularly can help combat the natural moisture build up.

9 Storm Braces

The storm braces will need to be altered during the buildings life as the moisture content within the log boards changes, altering the braces will help your building expand and contract properly. The boards will expand during periods of high moisture (Winter) and shrink during periods of low moisture (Summer).

Ensure each bolt is tightened using a washer so as not to damage the log boards.

10 Clean & Tidy

It is good practice to clean the inside and outside of your product regularly. Clear out the contents, sweep the floor, remove dirt and cobwebs. Check for areas of damp and investigate the cause to remove and prevent future occurrences. Check the ground around your product for build up of debris such as leaves, remove and ensure there is clear ventilation underneath the floor.

Additional Playhouse Maintenance:

It is recommended that the following checks and maintenance are carried out at the beginning of each season as well as at regular intervals during the usage season.

- Check all nuts /bolts/ screws for tightness and tighten when required.
- Check for movement / opening of wood giving rise to protrusion of nail heads and tips.
- Check hinges.
- Replace defective parts in accordance with the manufacturers instructions.
- Check any crossbeams, suspensions and anchors.
- If a swing is included; check the swing seat, chains and ropes.

IF THESE CHECKS ARE NOT CARRIED OUT THE ACTIVITY TOY COULD BECOME A HAZARD

All our garden buildings have been designed and manufactured with care and attention to be the perfect addition to your outdoor space. To ensure you do get the best out of your new garden building and to increase the longevity we advise that you follow the product instructions and our manufacturer's recommendations as detailed below. Thank you for choosing a Mercia Garden product!

1 Choosing the most suitable location for your garden building...

A minimum of 60cm should be left around the perimeter of your garden building to allow access for maintenance, annual treatment and to allow air flow around the building.

Where possible you should avoid placing your garden building underneath large trees to prevent the tree causing damage to the building.

2 Preparing the base for your garden building...

All our buildings must be built on a firm, level base to ensure the longevity of the building and prevent the wood from distorting. We recommend either concrete, concrete slabs or a wooden base, such as our 'Portabase'.

The base should be slightly smaller than the external measurement of the building, i.e. the cladding should overlap the base, creating a run off for water and preventing water from pooling underneath the building.

We also recommend that the floor of the garden building is a minimum of 25mm above the surrounding ground level to avoid flooding.

3 After installation...

Once your garden building has been installed, it will need to be treated within 14 days (weather permitting) and annually to prevent the timber from deteriorating and to waterproof it. This is required to maintain the anti-rot guarantee.

Dip Treated buildings - Require a preservative treatment to protect against rot and decay

and a waterproof treatment to prevent water ingress.

Pressure Treated buildings - Require a waterproof treatment to prevent water ingress.

Log Cabins/Insulated Garden Rooms - Are supplied untreated and require a preservative and waterproofing treatment.

We also recommend using a silicon sealant on the inside and outside of the windows as soon as possible after assembly and treatment to fully seal the windows.

Roofing felt/covering should be checked annually and replaced or fixed accordingly.

4 General maintenance and wood characteristics

As wood is a natural material it may be affected by the following:

Shrinkage and warping - The timber used in the construction of your garden building will have retained some of its natural moisture content. The moisture content of the timber will vary, depending upon prevailing environmental conditions, which will result in the components either naturally expanding or contracting. As the components dry out, shrinkage may occur. A good waterproofing treatment from the start is the best protection to minimise the effect of moisture loss/intake.

In extended periods of very warm weather getting some moisture to the building will help the overall balance. You can do this by spraying it down lightly with a garden hose. In contrast, after snow fall try to remove the snow as best as possible from the roof to prevent moisture intake and to remove the extra weight.

Top tip - using a garden brush will help you to reach the highest part of the building to remove snow and any debris left from bad weather.

Damp and mould - During the winter months, cold and damp conditions can result in an increased amount of moisture within your garden building, especially when used infrequently. Condensation can form on the timber and other items stored within your garden building. If left this moisture is likely to cause mould and mildew.

To prevent the build-up of moisture, we recommend leaving the door or windows of your building open from time to time, to allow the fresh air to circulate. We also advise against storing wet or damp items in your garden building as this will also increase the level of moisture in the building. If mould or mildew does start to form within your building we recommend using an anti-mould cleaner to remove it and to prevent it spreading, which if left untreated could permanently damage your garden building.

Splits, cracks and knots - You may notice small splits and cracks in some components or holes may appear where knots shrink and fall out. This will not affect the structure of your Garden building however, if you wish to fill them this can be easily done using any good quality wood filler.

Sap - is naturally occurring in wood and may appear in some boards of your garden building. If you wish to remove the sap, we advise waiting until it is dry and then using a sharp knife to carefully remove it. If the removal of the sap causes a hole in the timber, we recommend using a good quality wood filler to fill it.

For more handy hints and tips on how to care and maintain your garden building please refer to the MGP Customer Portal at www.mgplogistics.co.uk

Any further questions?

Contact our
Customer Service Team via the MGP
Customer Portal at:
www.mgplogistics.co.uk

1

Manufacturer's Warranty

All Mercia Garden Products are supplied with a 1 year warranty on all parts against manufacturing defects.

This warranty does not cover movement, warping or splitting of timber products over time.

This warranty will be voided if any of the following occur:

1. The building has been customised or modified/adapted in any way.
2. The person claiming is not the original purchaser of the building.
3. Any damage has been caused by or as a result of misuse.
4. The building has not been maintained and cared for in accordance to our advisories and manufacturer's recommendations.
5. The building has not been treated annually or as per the manufacturer's recommendations, please ensure receipts are kept to validate this claim.
6. The building has not been erected, fitted or installed as per the supplier instructions.
7. The building has not been erected on a suitable sized firm flat, solid level concrete/slab base or placed on pressure treated bearers.
8. The building is or has been placed with 2 feet (600mm) of any obstructions (walls, trees, plants, fences etc.) which can allow moisture to penetrate the timber.
9. The roofing felt has been incorrectly fitted or damaged, allowing water ingress, or has not been properly maintained.
10. Any windows and joints have not been sealed, inside and out, with silicone or other watertight sealant.
11. Any timber has been cut, pierced or drilled without subsequent application of approved cut-end treatment.

2

Anti-rot Guarantee

Mercia Garden Products offer a 10 year anti-rot guarantee on all dip treated (a preparatory treatment) and 15 years on all pressure treated products. This guarantee covers solid timber against rot, decay, blue stain and insect attacks.

To validate the guarantee the building must be treated (as detailed within manufacturer's recommendations) within 14 days (weather permitting) of assembly and annually thereafter.

This guarantee does not cover movement, warping or splitting of timber products over time.

This guarantee will be voided if any of the following occur:

1. The building has been customised or modified/adapted in any way.
2. The person claiming is not the original purchaser of the building.
3. Any damage is caused by or as a result of misuse.
4. The building has not been maintained and cared for in accordance to our advisories and manufacturer's recommendations.
5. The building has not been treated annually or as per the manufacturer's recommendations, please ensure receipts are kept to validate this claim.
6. The building has not been erected, fitted or installed as per the supplier instructions.
7. The building has not been erected on a suitable sized firm flat, solid level concrete/slab base or placed on pressure treated bearers.
8. The building is or has been placed with 600mm of any obstructions (walls, trees, plants, fences etc.) which can allow moisture to penetrate the timber.
9. The roofing felt has been incorrectly fitted or damaged allowing water ingress, or has not been properly maintained.
10. Any windows and joints have not been sealed, inside and out, with silicone or other watertight sealant.
11. Any timber has been cut, pierced or drilled without subsequent application of approved cut-end treatment.



REGISTER FOR YOUR
ANTI-ROT
GUARANTEE TODAY

PLEASE SCAN HERE:

