

**0644AXUPVC0403HGDD1SW-V1**  
UPVC 44MM 4M X 3M APEX LOG CABIN.

**BEFORE YOU START PLEASE READ INSTRUCTIONS CAREFULLY**

- Check the pack and make sure you have all the items listed in the parts list provided.
- When you are ready to start, make sure you have the right tools at hand (not supplied - see the equipment list on next page).
- Ensure you have enough time to build the product to ensure the building is water tight.

**LOCATION FOR YOUR GARDEN BUILDING**

A minimum of 600mm should be left around the perimeter of your garden building to allow access for maintenance, annual treatment and to allow air flow around the building.

Where possible you should avoid placing your garden building underneath large trees to prevent the tree causing damage to the building.

**TIMBER**

As with all natural materials, timber can be affected during various weather conditions. For the duration of heavy or extended periods of rain, swelling of the wood panels may occur. Warping of the wood may also occur during excessive dry spells due to an interior moisture loss. Unfortunately, these processes cannot be avoided but can be helped. It is suggested that the outdoor building is sprayed with water during extended periods of warm sunshine and sheltered as much as possible during rain or snow.

Once your garden building has been installed it will need to be treated within 14 days (weather permitting) and annually to prevent the timber from deteriorating and to waterproof it. This is required to maintain the anti-rot guarantee.

Log Cabins/Insulated Garden Rooms - Are supplied untreated and require a preservative and waterproofing treatment.

**BUILDING A BASE**

When thinking about where the building and where the base is going to be constructed: Ensure that there will be access to all sides for maintenance work and annual treatment.

Ensure the base is level and is built on firm ground, to prevent movement. Refer to the contents page for the base dimensions. The base should be slightly smaller than the external measurement of the building, i.e. The cladding should overlap the base, creating a run off for water. It is also recommended that the floor be at least 25mm above the surrounding ground level to avoid flooding.

**TYPES OF BASE**

- Concrete 75mm laid on top of 75mm hard-core.
- Slabs laid on 50mm of sharp sand.
- Wooden base - Levelled / on posts / ground screws.

Whilst all products manufactured are made to the highest standards of safety and in the case of children's products independently tested to EN71 level, we cannot accept responsibility for your safety whilst erecting or using this product.

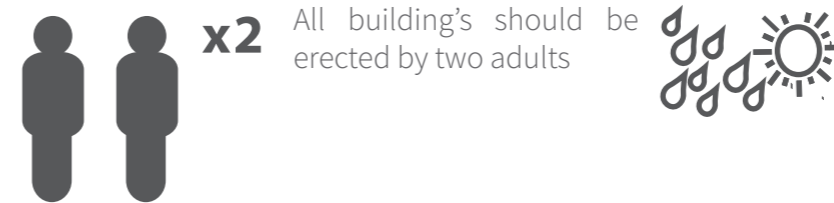

**x2** All buildings should be erected by two adults



Winter = High Moisture = Expansion  
Summer = Low Moisture = Contraction



**2mm Drill bit**

For ease of assembly, you **MUST** pilot drill all screw holes and ensure all screw heads are countersunk.



**CAUTION**  
Every effort has been made during the manufacturing process to eliminate the prospect of splinters on rough surfaces of the timber. You are strongly advised to wear gloves when working with or handling rough sawn timber.



For ease of assembly use a rubber mallet to fit the log boards. Do NOT use a heavy hammer.



Ensure to measure and check before cutting boards.

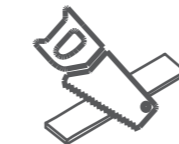

It is advisable to use a hand saw when cutting roof and floor boards.



To ensure log boards are even, use a spirit level to check each layer has been installed correctly.

**Screws & Nails**



Measure overall length

**Bolts**

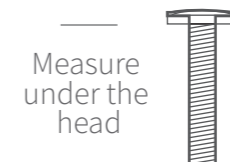

Measure under the head

To identify the fixings required for each step use a measuring tape.

**REGISTER FOR YOUR  
ANTI-ROT  
GUARANTEE TODAY**

PLEASE SCAN HERE:

In all instances for assistance with your product, please contact us via our customer portal: <https://www.mgplistics.co.uk/>.

Mercia Garden Products Limited,  
Sutton On Trent,  
Newark,  
Nottinghamshire,  
NG23 6QN



## TO DO LIST

- Find a suitable location to build *(see front cover for further information)*.
- Build a base *(see front cover for further information)*.
- Check the base is flat, level, clear of debris and has 60cm clearance on all sides.
- Check you have the required equipment / tools.
- Check you have all the product items listed *(if you have missing or damaged parts please scan the QR code below to visit our online customer portal)*
- Install the product as per the step by step instructions within this pack.
- Prepare the product ready for treatment (This may include sanding).
- Apply a preserving and a waterproofing treatment within 14 days *(weather permitting)* of installation.
- Register for your anti rot guarantee *(scan the QR below)*.
- Tidy the build area and dispose of any remaining parts responsibly.
- Maintain your building *(see the manufacturers recommendations at the back of this pack)*.

## EQUIPMENT LIST

- Hammer
- Mallet
- Flat Head Screwdriver
- Drill
- Drill Bit Set
- Phillips and Slotted Bit Sets
- Tape Measure
- Hand Saw
- Spirit Level
- Ladders/Steps
- Stanley Knife/Cutting Tool
- Sand Paper
- Sealant Application Gun
- Scraper
- Gloves
- Silicone (For Windows Only)
- Wood Filler (Optional)
- Timber Preservative Treatment
- Timber Water Proofing Treatment
- Treatment Mixing Stick
- Paint Brush/Sprayer/Roller

## NEED EXTRA SUPPORT

If you are unsure that your base preparation will be suitable, please contact us via our customer portal to discuss this further.

Alternatively, you can visit our website or MGP Logistics Online Portal for some further sheducation.

### Website:

<https://www.merciagardenproducts.co.uk/sheducation>

### MGP Logistics Online Portal:

<https://www.mgplogistics.co.uk/>

Here you will find plenty of useful information that'll help with most pre-installation and maintenance queries.

PLEASE SCAN HERE:



### ANY QUESTIONS?

Scan the QR code to contact us via our customer portal.

## NOTES

Before assembly please make sure you have a suitable base ready to erect your building

**MADE IN GREAT BRITAIN**

**Overall Dimensions:** Width = 4141mm  
 Depth = 3428mm  
 Height = 2744mm

**Base Dimensions:** Width = 3818mm  
 Depth = 2814mm

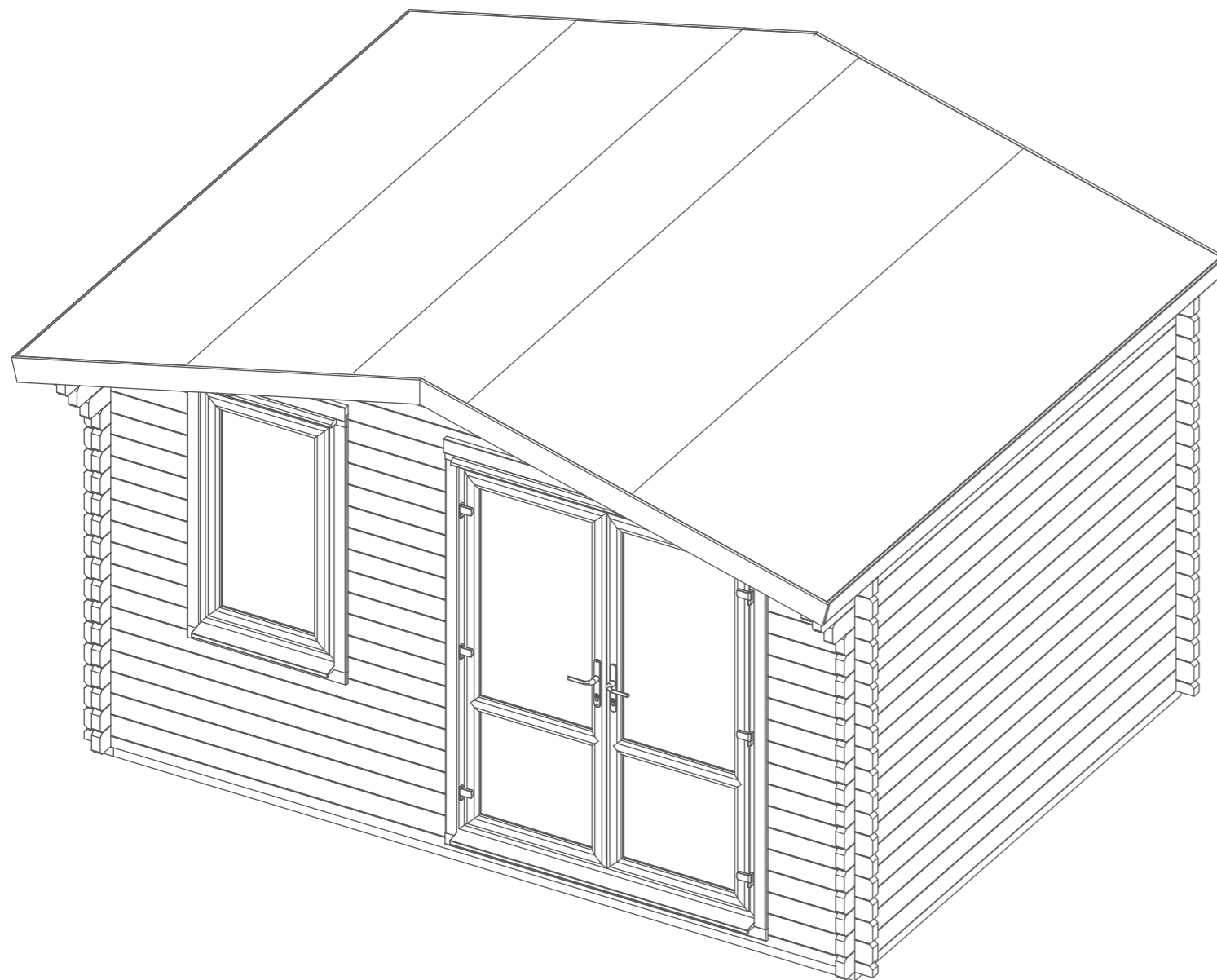

PLEASE SCAN HERE:

**ANY QUESTIONS?**  
 Scan the QR code to contact us via our customer portal.











Tip: Labelling your parts, using a pencil and masking tape, may help you to identify them easier when you need them.

*NO.1 STARTER BOARD*

**Log Boards Contents:**



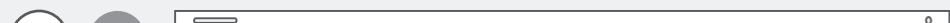



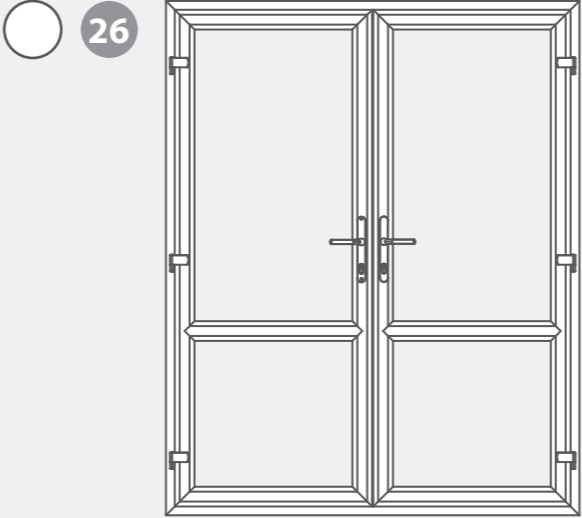
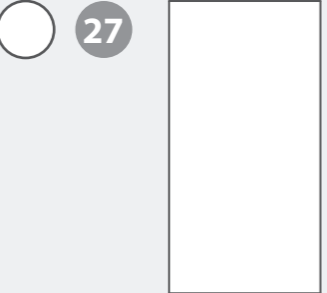
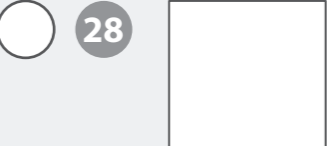

- 1 **Starter Board - 44x66x4000mm QTY 2**  
LB44RT66-A-4000mm
- 2 **Log Board - 44x120x2996mm QTY 32**  
LB44-A-2996mm
- 3 **Log Board - 44x120x4000mm QTY 19**  
LB44-A-4000mm
- 4 **Log Board - 44x120x1870mm QTY 6**  
LB44-B-1870mm
- 5 **Log Board - 44x120x560mm QTY 30**  
LB44-B-560mm
- 6 **Log Board - 44x120x560mm QTY 12**  
LB44-C-560mm
- 7 **Log Board - 44x120x4000mm QTY 1**  
LB44-AD-4000mm (1 x window, 1 x door cut out)
- 8 **Log Board - 44x120x3096mm QTY 2**  
LB44-AE-3096mm
- 9 **Log Board - 44x120x3196mm QTY 2**  
LB44-AE-3196mm
- 10 **Log Board - 44x120x3296mm QTY 2**  
LB44-AE-3296mm (Vent cut out)
- 11 **Log Board - 44x120x3396mm QTY 2**  
LB44-AE-3396mm
- 12 **Gable QTY 2**  
AI-0644AXNE0403HGDD1SW-G-V1

### Fixing Kit Contents:

- 
**13 Floor Bearer - 44x58x2814mm QTY 2**  
F4458-2814mm-PT
- 
**14 Floor Bearer - 44x58x3702mm QTY 10**  
F4458-3702mm-PT
- 
**15 Purlin - 45x120x3396mm QTY 3**  
F45120-AE-3396mm
- 
**16 Roof Board - 16x121x2114mm QTY 64**  
MB16-2114mm
- 
**17 Floor Board - 16x121x2722mm QTY 35**  
MB16-2722mm
- 
**18 Eaves Frame - 27x44x3396mm QTY 2**  
F2744-3396mm
- 
**19 Fascia - 16x120x3400mm QTY 2\***  
S16120-3400mm
- 
**20 Fascia - 16x120x2150mm QTY 4\***  
S16120-G-2150mm (1 x angled cut)
- 
**21 Closure Trim - 16x28x2400mm (approx length) QTY 11\***  
S1628-2400mm
- 
**22 Storm Brace - 44x27x2000mm QTY 8**  
F2744-2000mm
- 
**23 Plastic Vent QTY 4**  
PI-07-0237
- 
**24 Felt**
- 
**25 2mm Spacer QTY 5**  
PI-07-0208 (20x100x2mm)

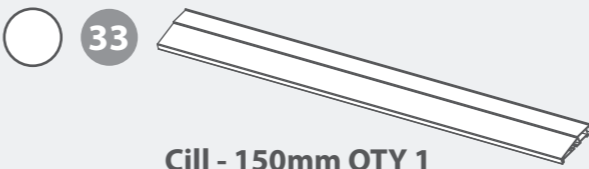
**\*This part will be longer than needed and requires cutting to size when used. This will be explained when required within the instruction step.**  
**Note: one piece may be required to be cut into multiple different sizes. Do not dispose of off-cuts until the building is fully constructed as they may be needed in another step.**

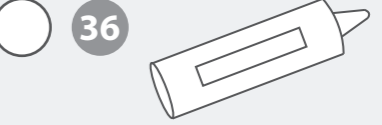
### Door Contents:

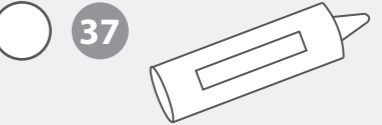
- 
**26 UPVC Double Doors QTY 1**  
(Morticed for lock)  
 PI-19-0119 White  
 PI-19-0120 Oak  
 PI-19-0121 Anthracite
- 
**27 Glass 521mm x 1071mm QTY 2**  
PI-19-0145
- 
**28 UPVC Small Panel 521mm x 421mm QTY 2**  
PI-19-0168 White  
 PI-19-0169 Oak  
 PI-19-0170 Anthracite
- 
**29 Door Frame Bottom - 88x60x1628mm QTY 1**  
AI-0644UPVCL0GDDBF-V1
- 
**30 Door Frame Top - 98x105x1632mm QTY 1**  
AI-0644UPVCL0GD DTF-V1
- 
**31 Door Frame Left - 88x60x2067mm QTY 1**  
AI-0644UPVCL0GDUFL-V1
- 
**32 Door Frame Right - 88x60x2067mm QTY 1**  
AI-0644UPVCL0GDUFR-V1
- 
**33 Cill - 150mm QTY 1**  
PI-19-0156 White  
 PI-19-0157 Oak  
 PI-19-0158 Anthracite
- 
**35 Rain Guard - 28x44x1520mm QTY 1**  
RG2844-1520mm
- 
**36 Clear Silicone QTY 2**  
ESDXL30ACC099
- 
**34 Cill End Cap - 150mm QTY 4**  
PI-19-0156 White  
 PI-19-0157 Oak  
 PI-19-0158 Anthracite
- 
**37 Colour Matched Silicone QTY 1**  
ESDXL30ACC109 - White  
 ESDXL30ACC110 - Oak  
 ESDXL30ACC111 - Anthracite

### Window Contents:

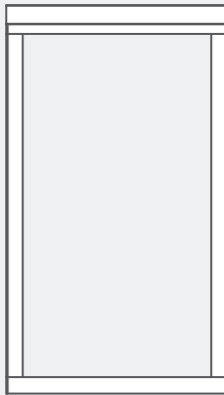
- 

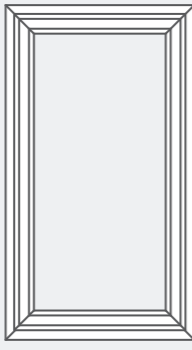
**38**  
**Window Frame QTY 1**  
AI-0644UPVCDGWF808X1417-V1
- 

**39**  
**UPVC Window QTY 1**  
PI-19-0125 White  
PI-19-0126 Oak  
PI-19-0127 Anthracite
- 

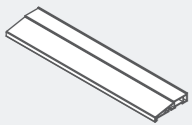
**40**  
**Glass**  
504mm x 1036mm QTY 1  
PI-19-0147
- 

**41**  
**Cill - 150mm QTY 1**  
PI-19-0162 White  
PI-19-0163 Oak  
PI-19-0164 Anthracite
- 

**42**  
**Rain Guard - 28x44x710mm QTY 1**  
RG2844-710mm
- 

**43**  
**Plastic Packers**  
PI-07-0239

### Pre-assembly

**\*Please note:**

Each board interlocks at either end in a staggered pattern.

Before securing ensure that the boards are fitted properly in their respective tongue's and groove's.

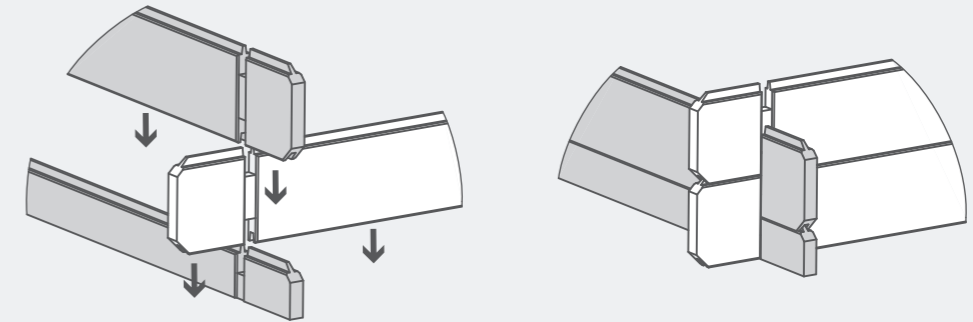

### Screw Pack.

There may be extra screws present in the pack.

- 

**90mm Bolt Set x 16**
- 

**40mm Screw x 496**
- 

**90mm Screw x 40**
- 

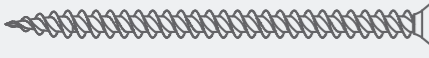
**30mm Screw x 80**
- 

**80mm Screw x 8**
- 

**20mm Screw x 8**
- 

**70mm Screw x 66**
- 

**Felt Tacks x 250**

PLEASE SCAN HERE:

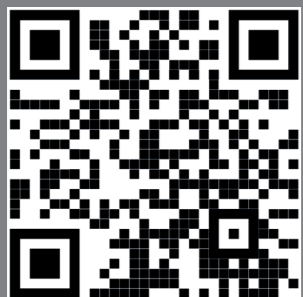

### Missing parts?

Scan the QR code to visit our customer portal where you can quickly raise any missing or damaged parts and get a replacement sent out ASAP.





**Step 1**

**Parts Needed - No. 13 QTY 2**  
**No. 14 QTY 2**

Lay the bearers (**No. 13 & 14**) onto a firm and level base (*free from areas where standing water can collect*) ensuring the bearers are flat and level and the ends are flush, as shown.

Ensure to lay the bearers so the widest face (58mm) is positioned on the flat, and the smaller face (44mm) is positioned as the height, as shown.

Fix the bearers together using 2x90mm screws per corner.

Once secured, ensure the bearers are square by measuring from corner to corner, making sure the measurements are equal. If the bearers are not aligned equally, unscrew, adjust and re-align accordingly.

**8x90mm Screws**  
**Important:** Pre-drill before fixing screws.

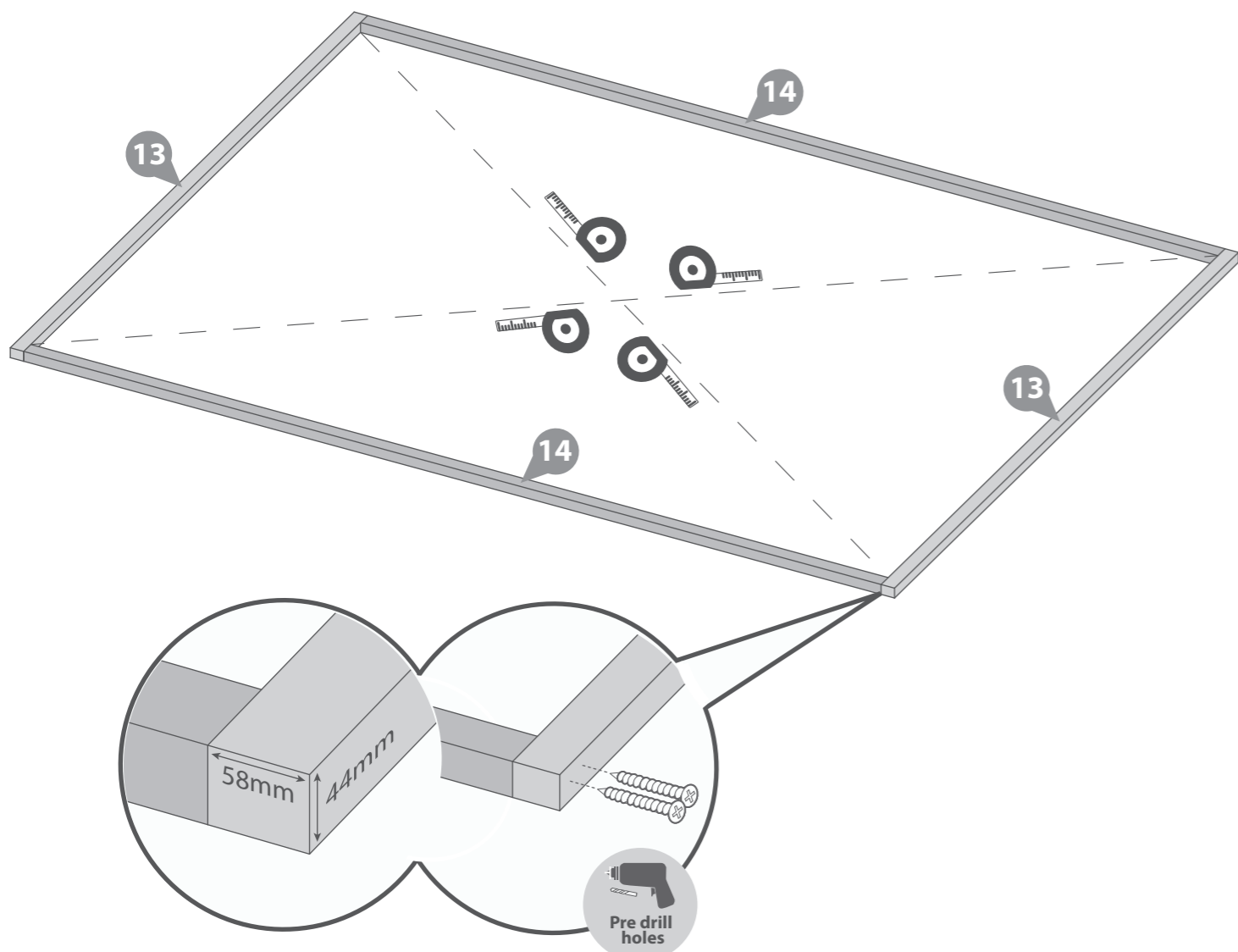
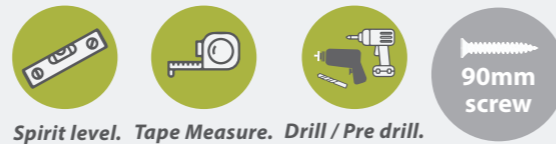

**Step 2**

**Parts Needed - No. 14 QTY 8**

Following the same method shown in the previous step, arrange the remaining bearers (**No. 14**) inside the assembled frame, ensuring each piece is flush and level.

Ensure to lay the bearers so the widest face (58mm) is positioned on the flat, and the smaller face (44mm) is positioned as the height, as shown.

**\*Ensure there is an equal amount of space between each bearer.**

Secure each of the bearers in place by screwing through the outside framing into the framing behind using 2x90mm screws for each end of the bearer, as shown.

**32x90mm Screws**  
**Important:** Pre-drill before fixing screws.

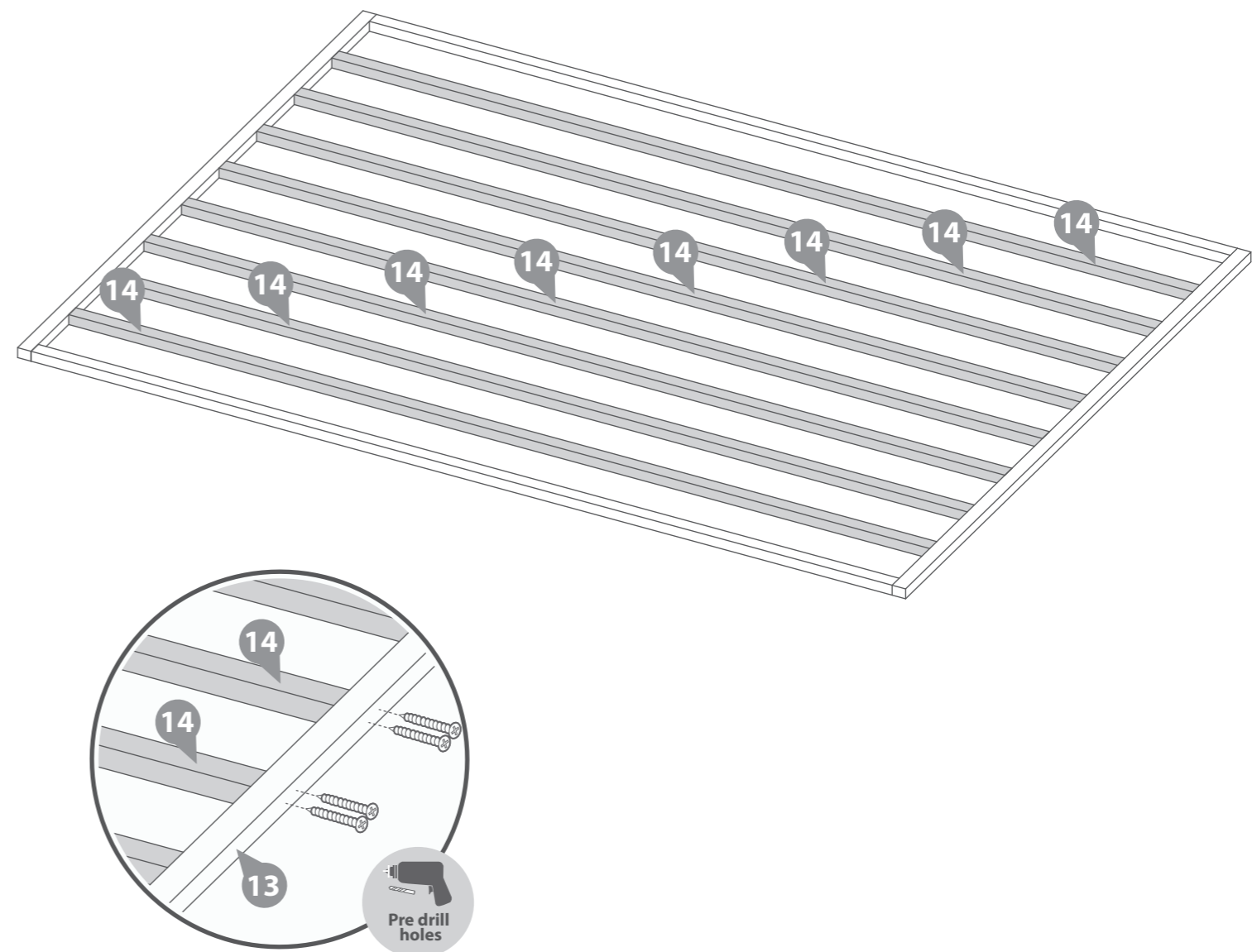
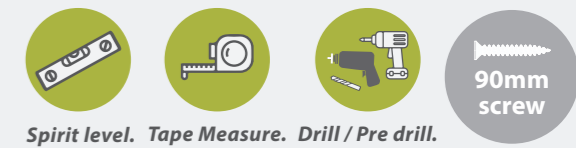

**Step 3**

**Parts Needed - No. 1 QTY 2**  
**No. 2 QTY 2**

Place the starter boards (**No.1**) on to the front and back of the assembled bearers and lightly position the first two log boards (**No. 2**) into the notches as shown.

Ensure the boards sit square on the base using the same method used in Step 1. Measure corner to corner, making sure the measurements are equal.

Once the boards are square, lift up the log boards (**No. 2**) and fix the starter boards in place by screwing through the notch into the bearer below, using 1x70mm screw per notch.

**Note: Use a mallet and a scrap piece of wood to gently persuade the log boards into place.**

**4x70mm Screws**  
**Important: Pre-drill before fixing screws.**



Rubber Mallet.



Drill / Pre drill.

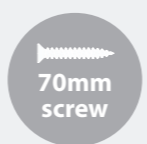

70mm screw

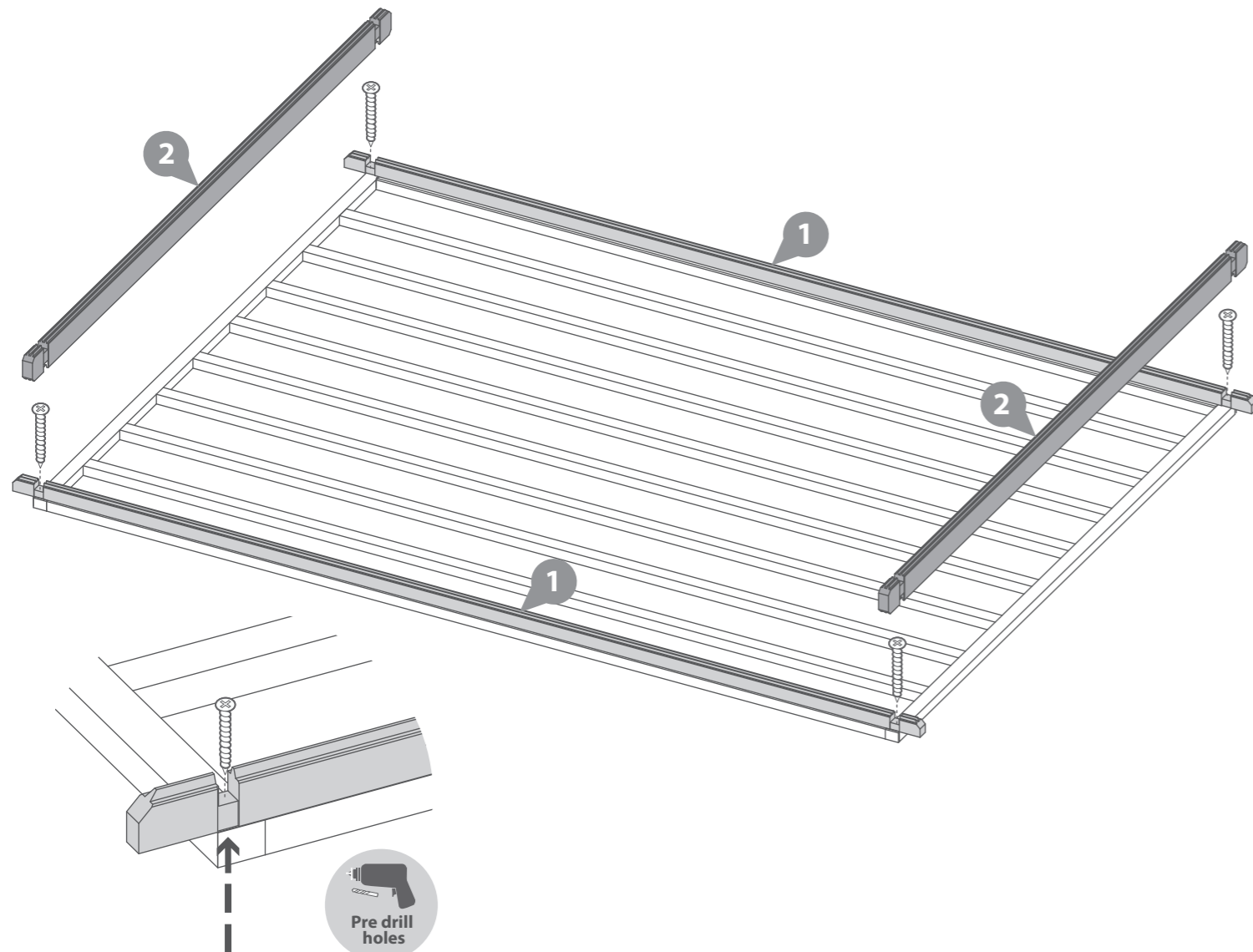

**Step 4**

**Parts Needed - No. 2 QTY 12**  
**No. 3 QTY 6**  
**No. 4 QTY 6**  
**No. 5 QTY 6**

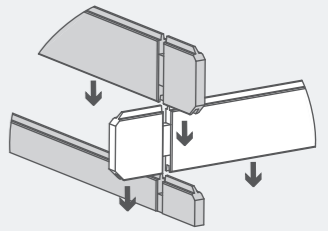

Following the method shown in the illustration, lay the first 6 boards (**No. 2, 3, 4 & 5**) off of the starter boards to create your first level.

**\*Ensure that the boards are level and flush with each other as you lay each one.**

Start by placing the front and back boards, interlocking them with the side boards. Then place the next side boards, interlocking with the front and back boards. Continue this method until you have placed **6 boards off of the starter boards on each side**, as shown.

Please note: The short boards at the front (either side of the door opening) of the building can be placed either side depending on where you'd like your door to be positioned.



Rubber Mallet.

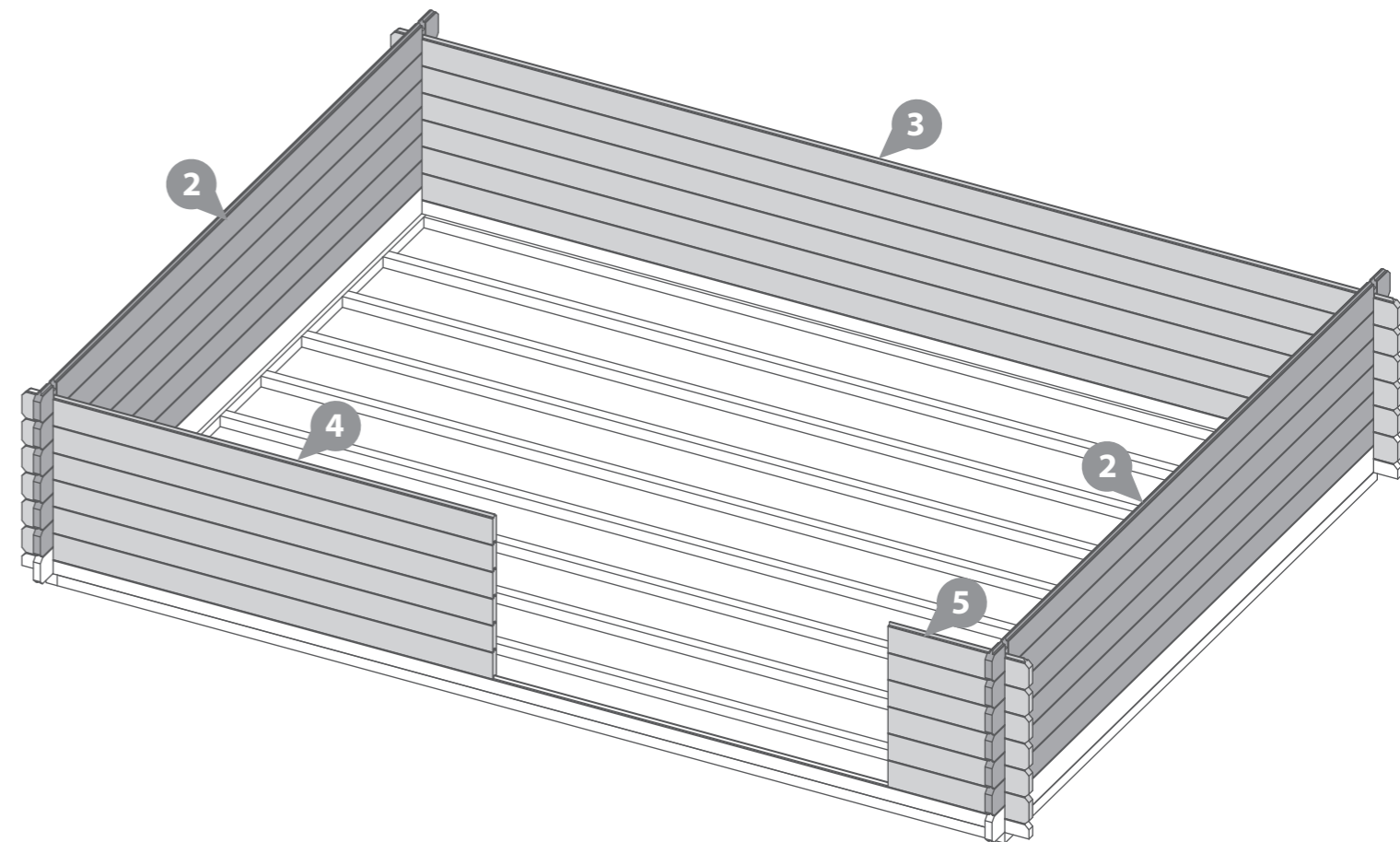

**Step 5**

- Parts Needed - No. 29 QTY 1**
- No. 30 QTY 1**
- No. 31 QTY 1**
- No. 32 QTY 1**

Arrange the left, right, top & bottom door frames (**No. 29, 30, 31 & 32**) onto a flat and level surface.

Secure the top and bottom frames to the uprights using 2x80mm screws per corner, ensuring the screws do **NOT** protrude through the front of the door framing.

**8x80mm Screws**  
**Important:** Pre-drill before fixing screws.

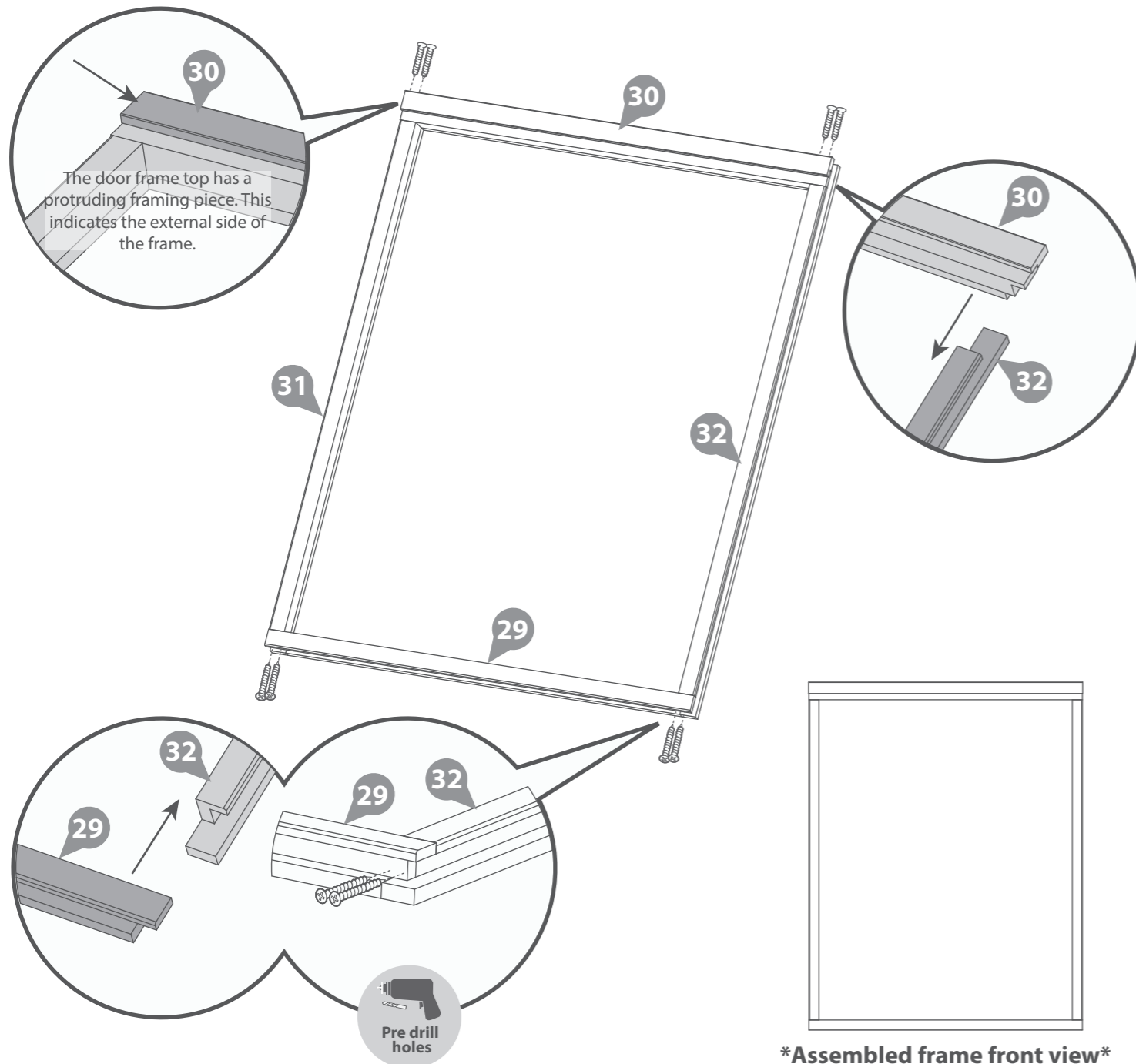

**Step 6**

Once you have laid 6 log boards (off of the starter board) up the door section, slide the assembled door frame over the boards, ensuring to rest the frame on top of the starter board. *If you have not yet assembled your door frame, please refer to step 5.*



Rubber Mallet.

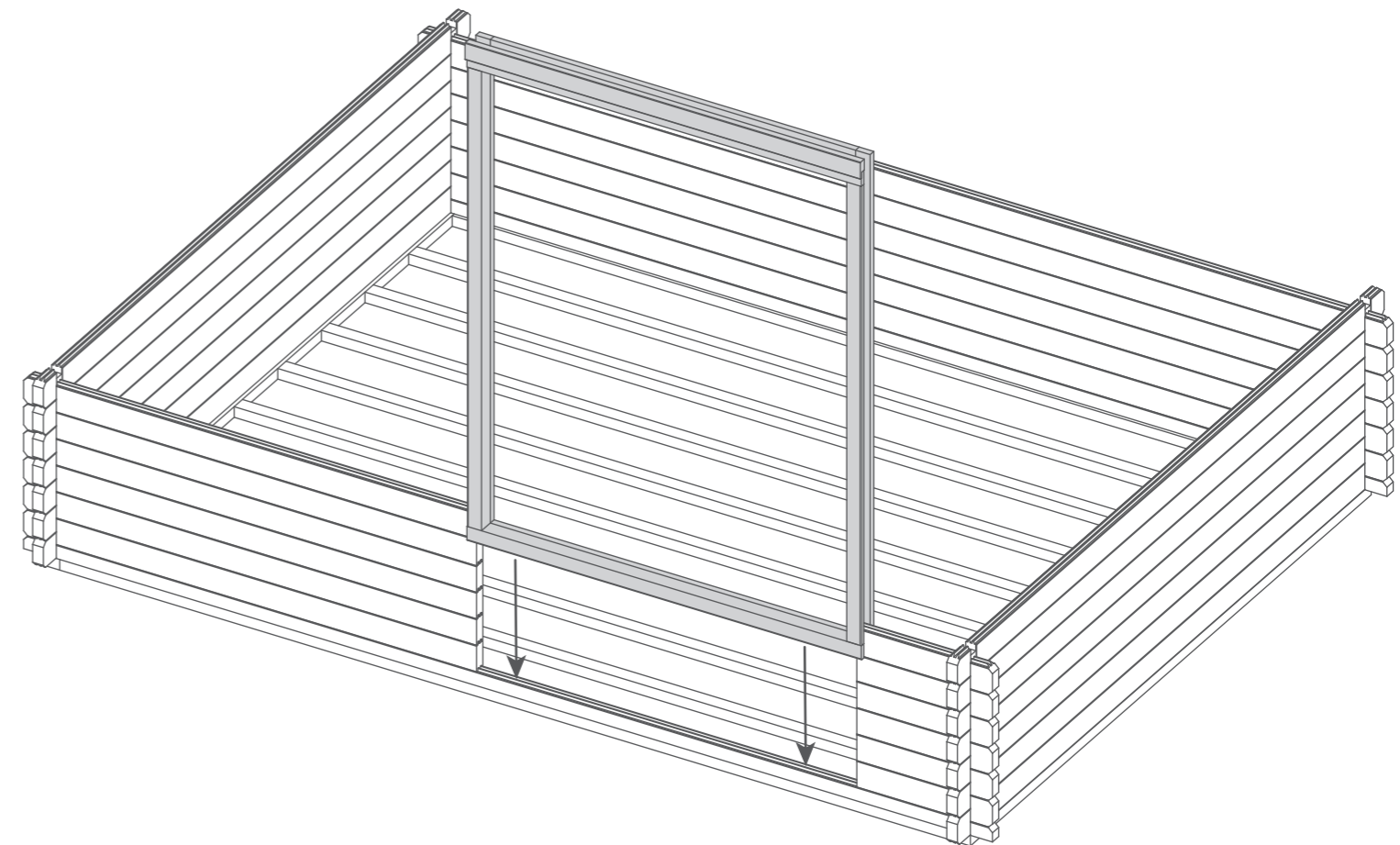



### Step 7

Parts Needed - No. 2 QTY 12  
No. 3 QTY 6  
No. 5 QTY 12  
No. 6 QTY 6

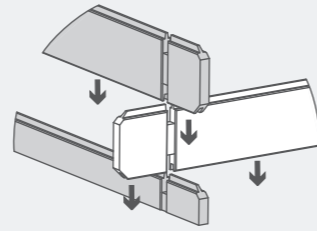

Following the method shown in the illustration, lay the next 6 boards (No. 2, 3, 5 & 6) on to the log cabin to create your second level.



Rubber Mallet.

*\*Ensure that the boards are level and flush with each other as you lay each one.*

### Step 8

Parts Needed - No. 38 QTY 1

Once you have laid 6 log boards up the window section, slide the assembled Window frame (No. 38) over the boards, ensuring to rest the frame on top of the board below.



Rubber Mallet.

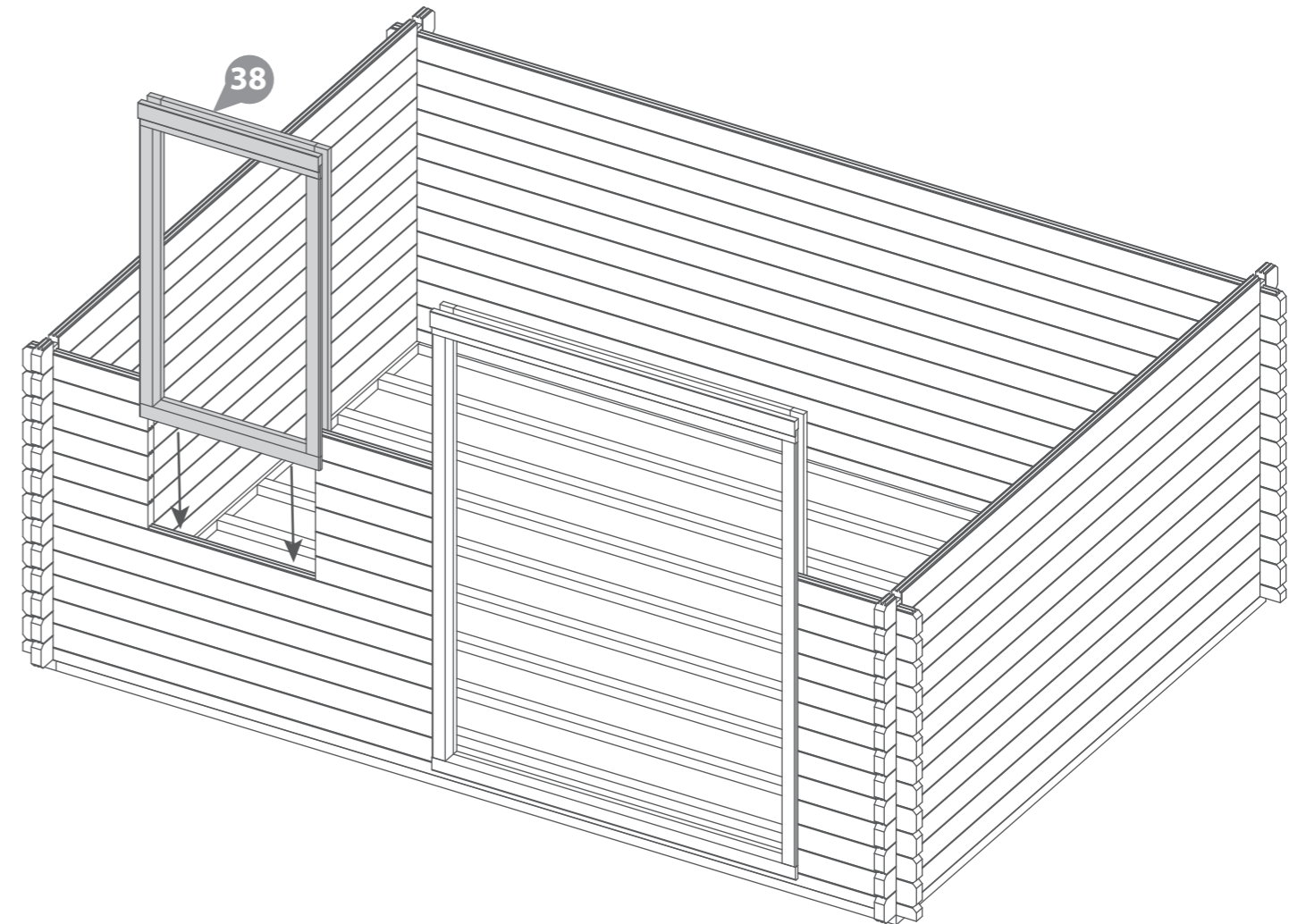

**Step 9**

**Parts Needed - No. 10 QTY 2**  
**No. 23 QTY 4**

Lay the Log Boards (**No. 10**) onto a flat and level surface and locate one Vent (**No.23**) into each vent hole, as shown. Secure in place using 2x20mm screws per Vent.

Flip the Log Boards (**No. 10**) over and position the remaining Vents (**No. 23**) into the opposite side of the Vent holes. Fix in place using 2x20mm screws per vent.

On one side of each gable, the vent will need to be slightly offset to an angle to ensure the screws do not collide.

**8x20mm Screws.**  
**Important: Pre-drill before fixing screws.**

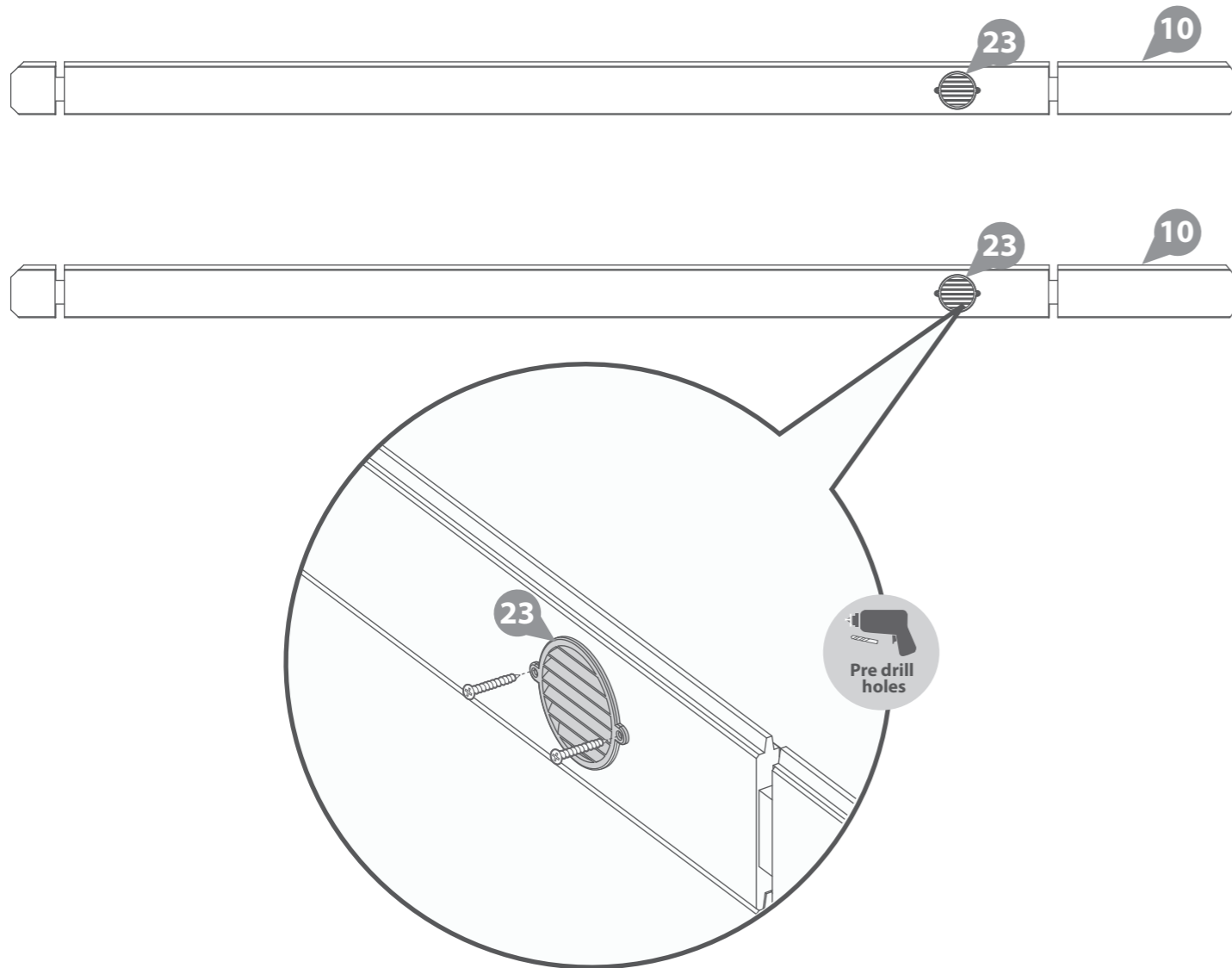
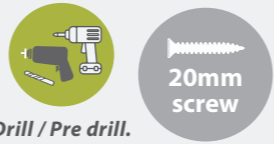

**Step 10**

**Parts Needed - No. 2 QTY 6**  
**No. 3 QTY 6**  
**No. 5 QTY 12**  
**No. 6 QTY 6**  
**No. 8 QTY 2**  
**No. 9 QTY 2**  
**No. 10 QTY 2**

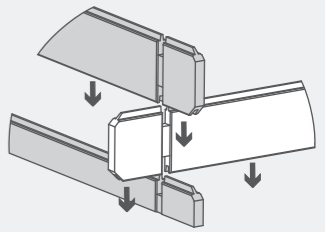

Following the method shown in the illustration, lay the next 6 boards (**No. 2, 3, 5, 6, 8, 9 & 10**) on to the log cabin to create your next level. Ensure to lay the boards so they create a staggered overhanging pattern at the front of the building, as shown.

**\*Ensure that the boards are level and flush with each other as you lay each one.**

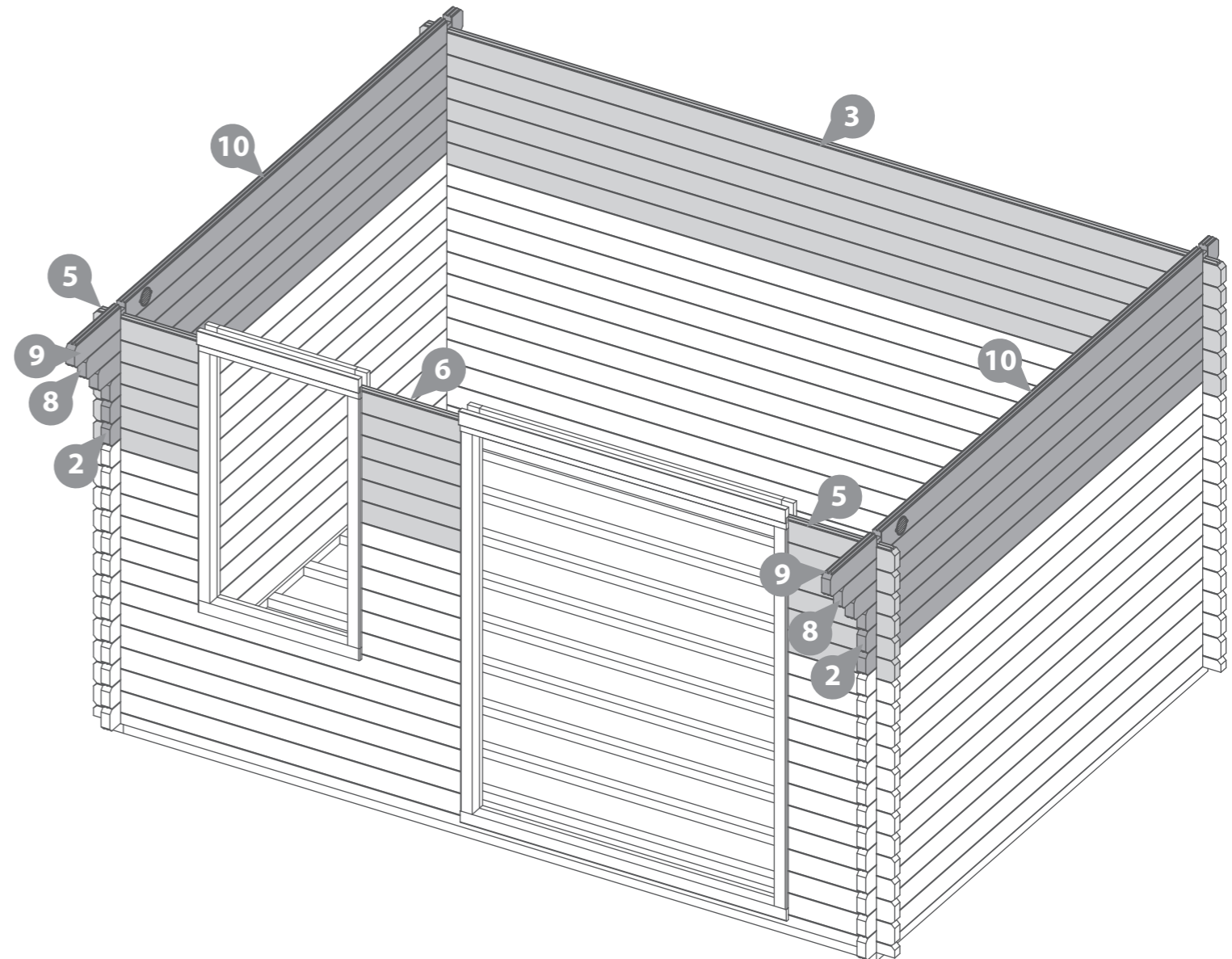

**Step 11**

**Parts Needed - No. 3 QTY 1  
No. 7 QTY 1  
No. 11 QTY 2**

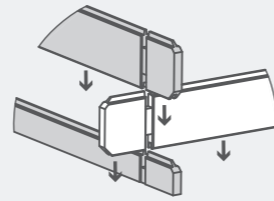

Following the method shown in the illustration, lay the next layer of boards (**No. 3, 7 & 11**) onto the log cabin.

**\*Ensure that the boards are level and flush with each other as you lay each one.**

Fix the top boards to the boards below by screwing through the notch using 1x70mm screw per corner, as shown in the illustration.

**4x70mm Screws**  
**Important: Pre-drill before fixing screws.**

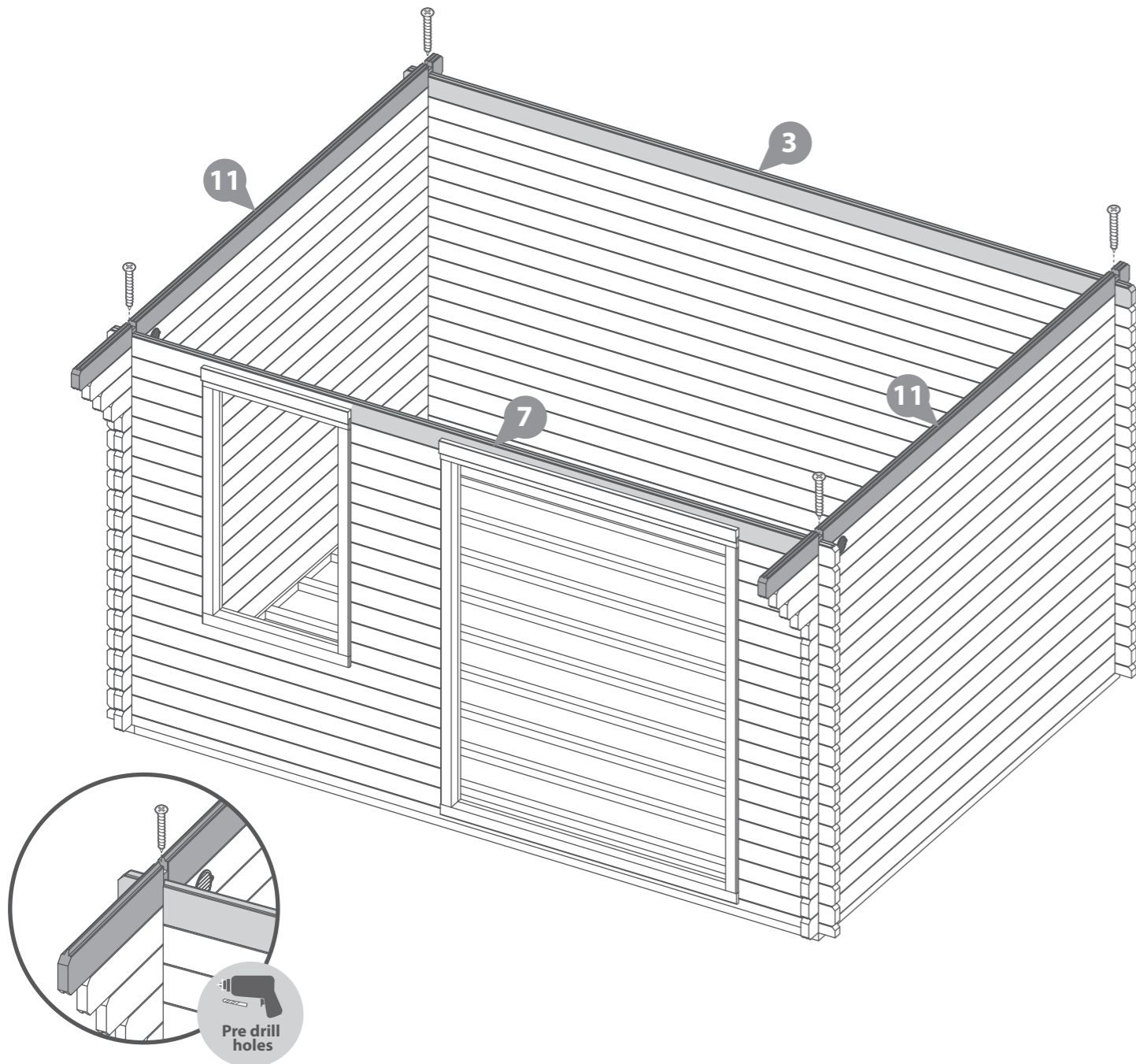

**Step 12**

**Parts Needed - No. 12 QTY 2**

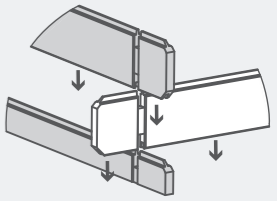

Following the method shown in the illustration, locate the Gables (**No. 12**) onto the front and back of the log cabin.

**\*Ensure that the boards are level and flush with each other as you lay each one.**

Fix the gables to the boards below by screwing through the notch using 1x70mm screw per corner, as shown in the illustration.

**4x70mm Screws**  
**Important: Pre-drill before fixing screws.**

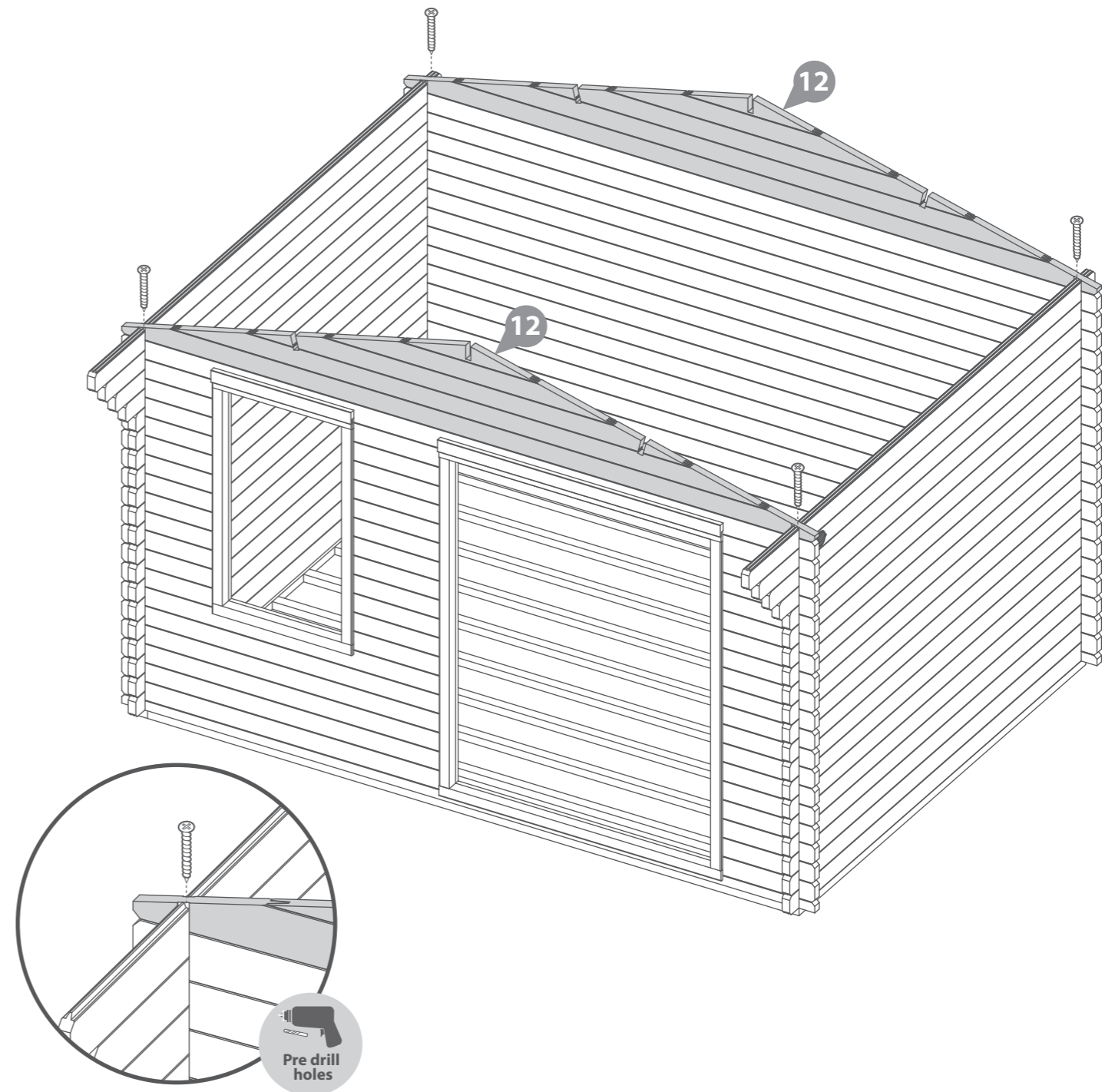



**Step 13**

**Parts needed - No. 15 QTY 3**

Align the Purlins (**No.15**) into the cut out notches on the Gables, ensuring they interlock.

**Note: Use a mallet and a scrap piece of wood to gently fix the purlins into position.**

Secure the roof purlins by screwing through the purlin into the gable (*ensure to pre-drill to avoid the boards splitting*) using 2x70mm screws per notch.

**12x70mm Screws**

**Important: Pre-drill before fixing screws.**

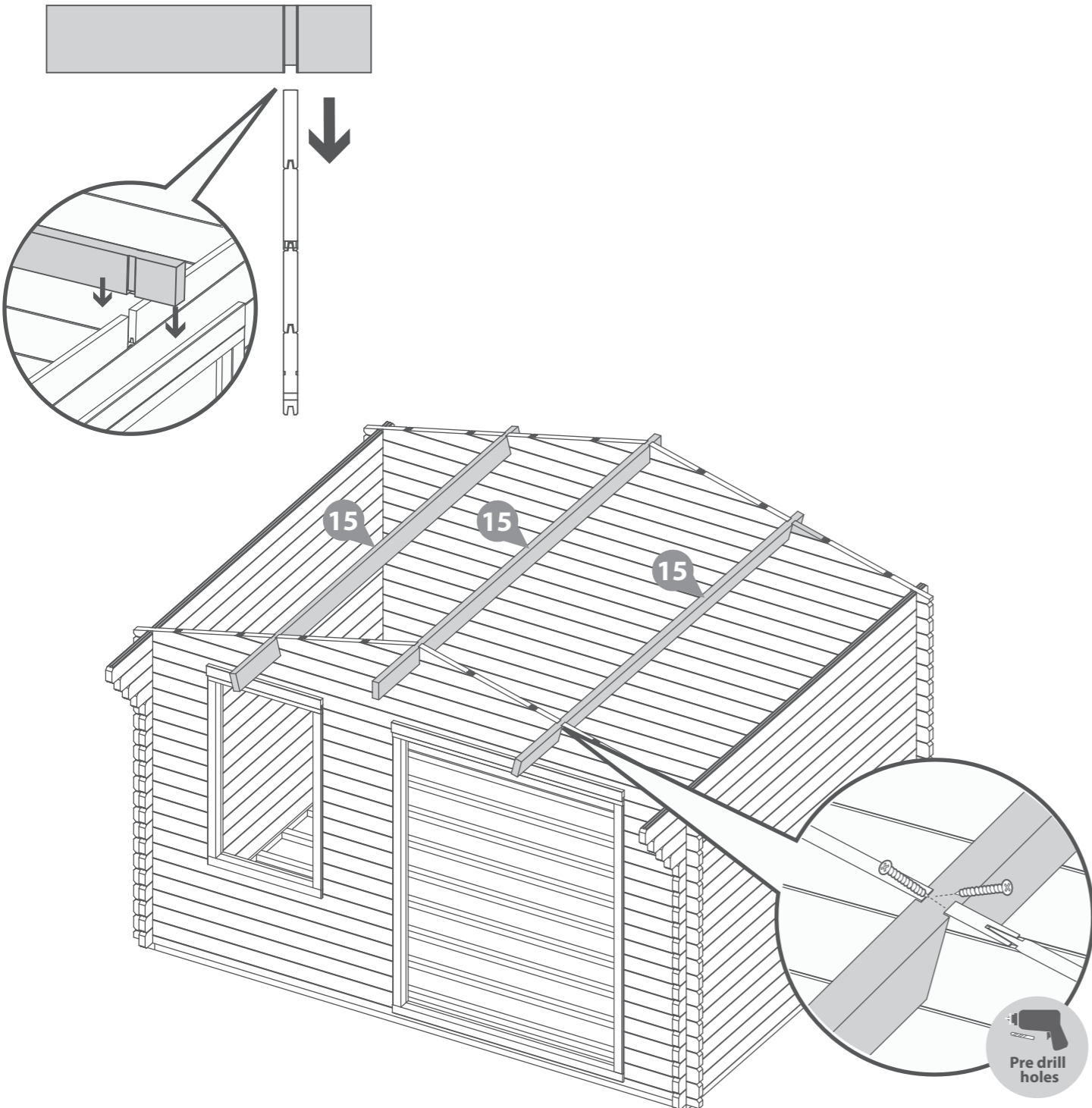

**Step 14**

**Parts needed - No. 16 QTY 64**

**No. 25 QTY 5**

**a** Place the first two roof boards (**No. 16**) onto either side of the log cabin, making sure the boards are flush to the end of the roof purlin. Once in position fix to each purlin or log board below using 3x40mm screws.

Continue adding the roof boards along the roof, fixing each one into position using 3x40mm screws, making sure that each board is interlocked, flush at the bottom and meets another at the top of the apex. **\*Ensure the roof boards meet at the top of the apex and leave an overhang at the bottom.**

To ensure the roof boards are not laid too close together, use the 2mm spacers (**No.25**) provided to create a 2mm gap. Adjusting the spacing between the boards allows the wood to swell in damp weather.

You have been issued with 64 roof boards, but you may only need to use 62.

**b** The last board will overhang past the Purlins. Using a straight edge and a pencil, mark out a line as a guide.

Saw along the pencil mark and remove the excess. Place the cut down boards back onto the roof and secure into place using 3x40mm screws per board.

**192x40mm Screws**

**Important: Pre-drill before fixing screws.**

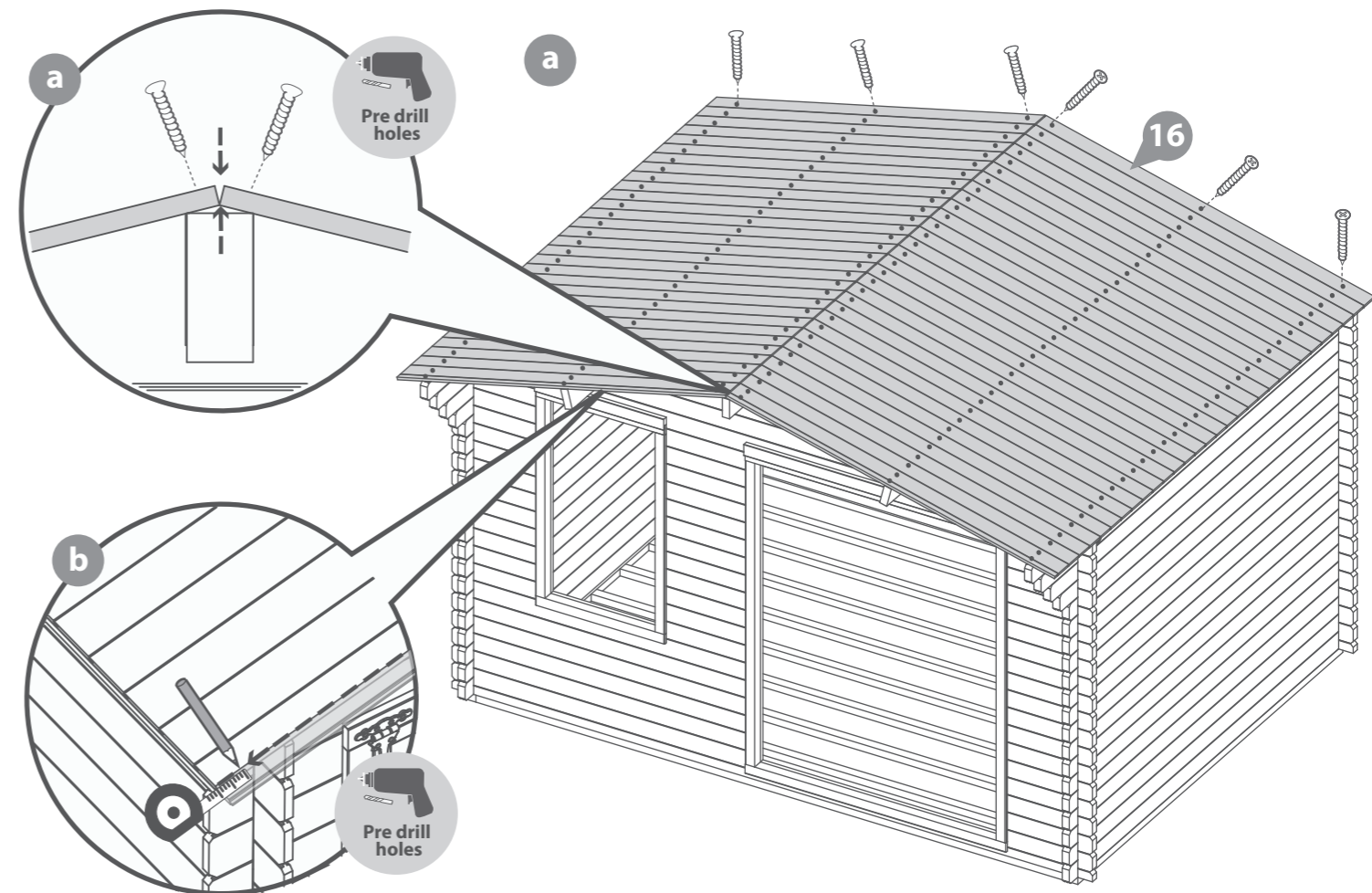



**Step 15**  
**Parts Needed - No. 18 QTY 2**

Ensuring the roof boards are flush and level, locate the Eaves Frames (**No. 18**) to the underside of the roof boards on either side of the log cabin. Secure in place using 7x30mm screws per frame, as shown in the illustration.

**14x30mm Screws**  
**Important:** *Pre-drill before fixing screws.*

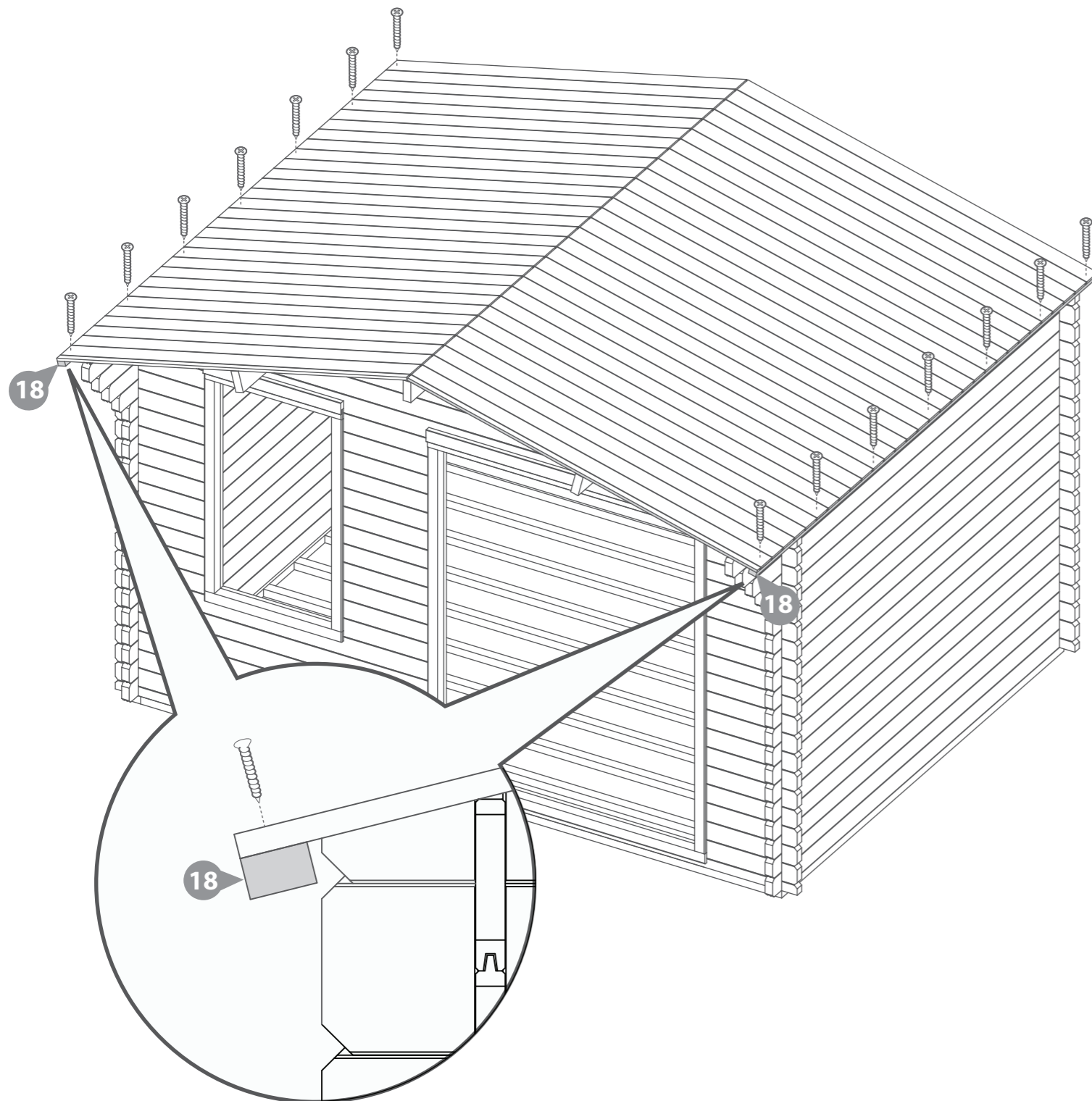

**Step 16**

- Parts Needed - No. 26 QTY 1**  
**No. 33 QTY 1**  
**No. 34 QTY 2**  
**No. 36 QTY 1**  
**No. 43 QTY 1**

**a** The cill (**No. 33**) for the bottom of the doors will be slightly larger than required, this will require cutting to size before fitting. Measure the bottom of the UPVC door frame (**No. 26**) and record the length. Using a pencil, mark the desired length minus the thickness of the two end caps (**No. 34**) and cut with a saw.

Once cut, place onto the bottom of the frame opening and check the fit. Place the UPVC door frame (**No. 26**) central in the door opening. There should be a tolerance gap between the UPVC door (**No. 26**) and the frame at the top and either side. Measure the gap, this gap is to be distributed on all four sides using the packers (**No. 43**) provided.

**Remove the UPVC frame and cill, place to one side.**

**b** Apply clear silicone (**No. 36**) to the edge of the cill (**No. 33**), secure the end caps (**No. 34**) to both ends of the cill.

**c** Place plastic packers (**No. 43**) along the bottom of the door frame which add up to half the vertical tolerance gap measured and then place the cill on top. Position the cill (**No. 33**) with the back edge flush with the internal frame. Measure from the top of the cill to the top of the opening to ensure the gap is equal, measure in a few places along the cill to be sure.

Remove the cill (**No. 33**) and apply a clear silicone (**No. 36**) bead along each corner and a wiggled line along the full width. Place the cill (**No. 33**) down onto the area the silicone was applied, apply pressure to ensure the cill is sitting on the spacers.

Fix the cill (**No. 33**) to the door frame using 4 x 70mm screws, fixing through the flat area at the back of the cill. Ensure to pre-drill the screw holes and finish the screw heads flush with the cill surface.

**4x70mm Screws**

**Important:** Pre-drill before fixing screws.



Sealant application gun.



Tape Measure.



Spirit level.



Saw.



Drill / Pre drill.

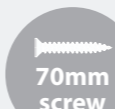

70mm screw

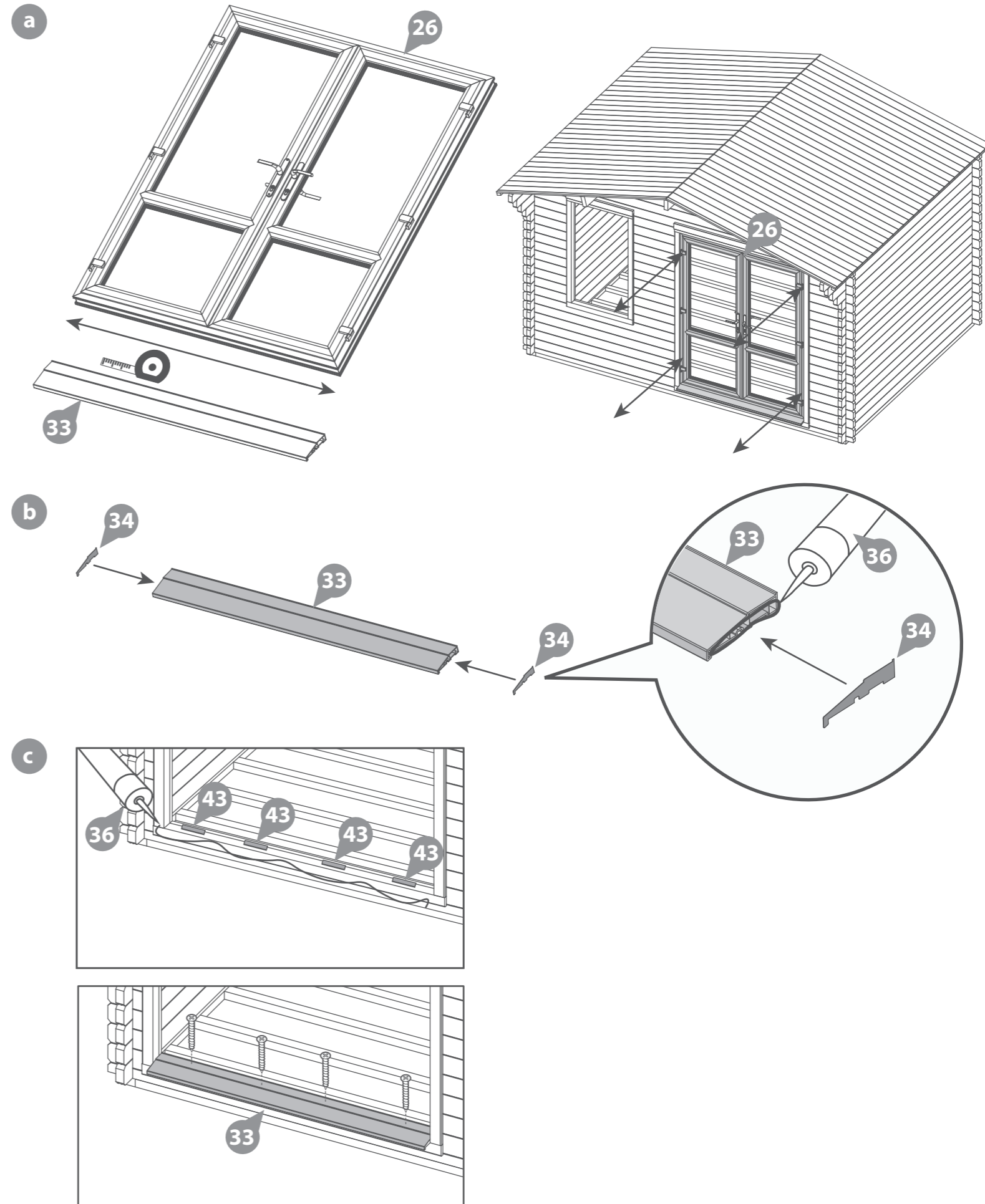

**Step 17**

- Parts Needed - No. 26 QTY 1**  
**No. 33 QTY 1**  
**No. 36 QTY 1**  
**No. 37 QTY 1**  
**No. 43 QTY 1**

- a** Apply beads of clear silicone (**No. 36**) along the flat face of the cill (**No. 33**), along the front, back and both sides.
- b** Position the UPVC door frame (**No. 26**) onto the cill, the UPVC door frame should sit flush with the internal wall. Use the plastic packers (**No. 43**) provided to place between the UPVC and the door frame. These stop the UPVC frame from bowing when the screws are fixed. Position multiple along the sides and top.

*Use a pen or a small thin implement to push the packers into place.*

- c** Open the doors to expose the internal frame, the frame is not fixed in position and will require supporting. Along all four sides pre-drill four holes. Fill the screw holes with clear silicone (**No. 36**) and then fix the UPVC door frame (**No. 26**) to the door frame and the cill using 70mm screws.
- d** Seal around the UPVC door frame, using the colour matched silicone (**No. 37**) apply a bead around both sides and the top of the frame. Be careful to apply a neat line which runs between the UPVC and timber frame.

**Following the door installation, if you have any issues with the doors catching or not opening and closing smoothly, see pages 26 - 29 for adjustment advice. It is best to make alterations once the glass has been fitted. The weight of the glass can alter door positioning.**

**16x70mm Screws**

**Important:** Pre-drill before fixing screws.

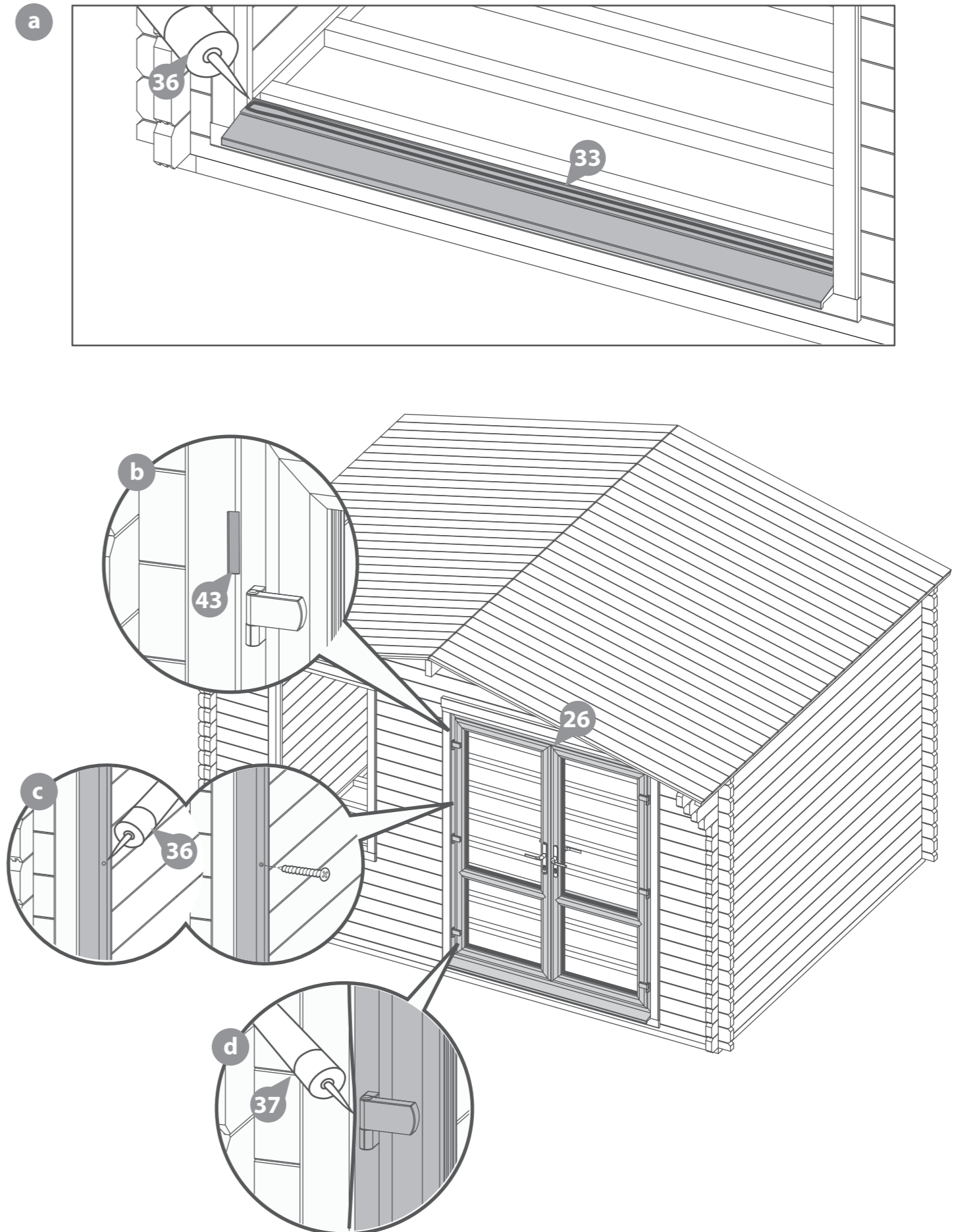
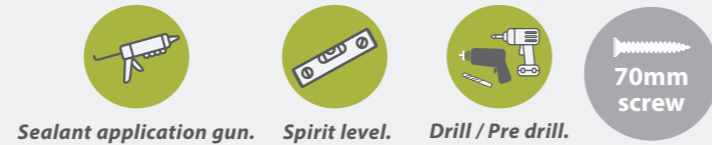



**Step 18**

**Parts Needed - No. 34 QTY 2**

**No. 36 QTY 1**

**No. 39 QTY 1**

**No. 41 QTY 1**

**No. 43 QTY 1**

- a** The cill (**No. 41**) for the bottom of the windows will be slightly larger than required, this will require cutting to size before fitting. Measure the bottom of the UPVC window frame (**No. 39**) and record the length. Using a pencil, mark the desired length minus the thickness of the two end caps (**No. 34**) and cut with a saw.

Once cut, place onto the bottom of the frame opening and check the fit. Place the UPVC window frame (**No. 39**) central in the window opening. There should be a tolerance gap between the UPVC window (**No. 39**) and the frame at the top and either side. Measure the gap, this gap is to be distributed on all four sides using the packers (**No. 43**) provided.

**Remove the UPVC frame and cill, place to one side.**

- b** Secure the cill end caps (**No. 34**) to the cill (**No. 41**) using clear silicone (**No. 36**).
- c** Place plastic packers (**No. 43**) along the bottom of the window frame which add up to half the vertical tolerance gap measured and then place the cill on top. Position the cill (**No. 41**) with the back edge flush with the internal frame. Measure from the top of the cill to the top of the opening to ensure the gap is equal, measure in a few places along the cill to be sure.

Remove the cill (**No. 41**) and apply a clear silicone (**No. 36**) bead along each corner and a wiggled line along the full width. Place the cill (**No. 41**) down onto the area the silicone was applied, apply pressure to ensure the cill is sitting on the spacers. Check the cill is flush internally

Fix the cill (**No. 41**) to the window frame using 3 x 70mm screws, fixing through the flat area at the back of the cill. Ensure to pre-drill the screw holes and finish the screw heads flush with the cill surface.

**3x70mm Screws**

**Important:** Pre-drill before fixing screws.

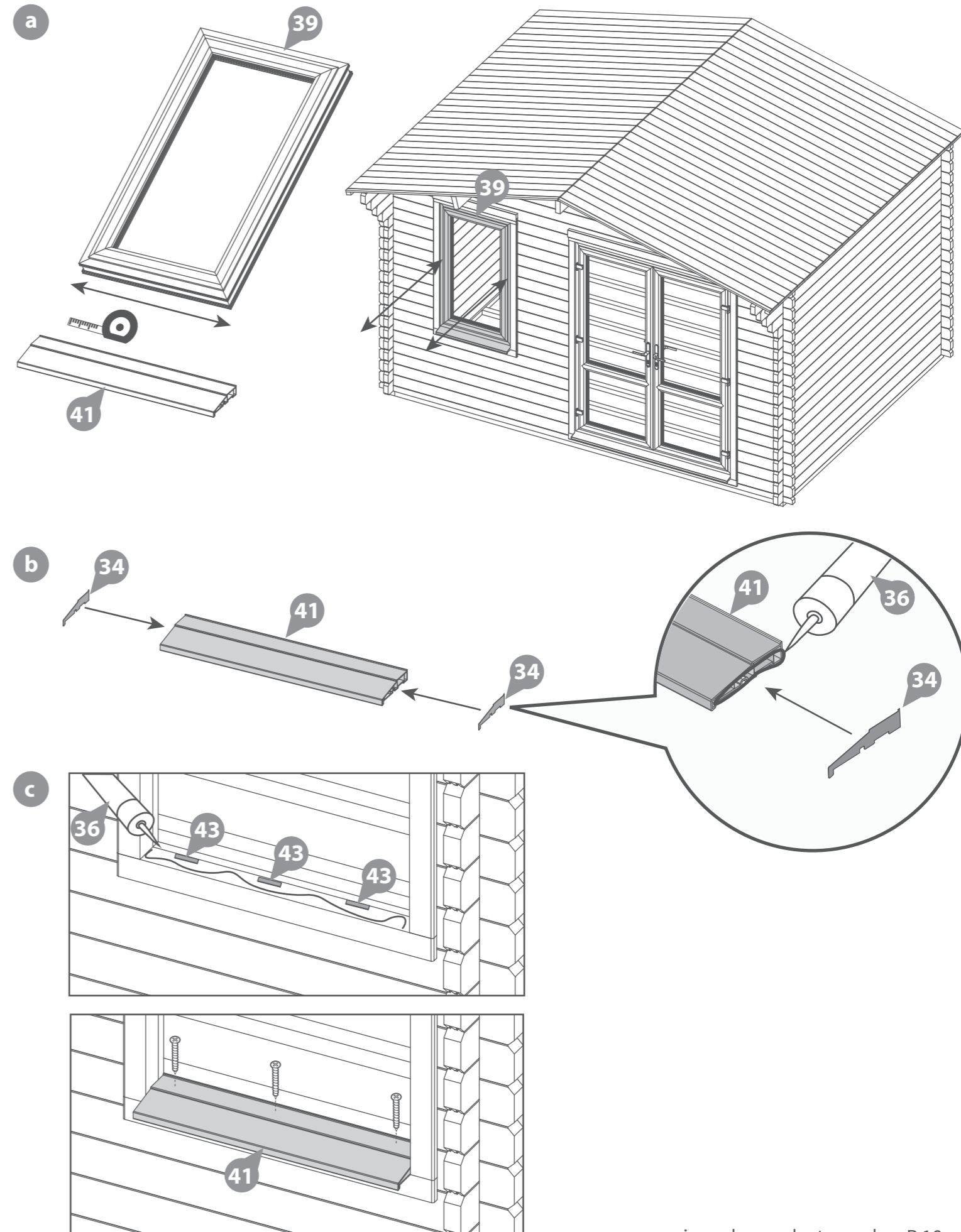
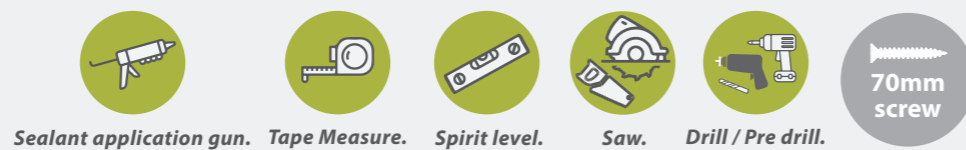



**Step 19**

- Parts Needed - No. 36 QTY 1**  
**No. 37 QTY 1**  
**No. 39 QTY 1**  
**No. 41 QTY 1**  
**No. 43 QTY 1**

- a** Apply beads of clear silicone (**No. 36**) along the flat face of the cill (**No. 41**), along the front, back and both sides.
- b** Position the UPVC window frame (**No. 39**) onto the cill, the UPVC window frame should sit flush with the internal wall. Use the plastic packers (**No. 43**) provided to place between the UPVC and the window frame these stop the UPVC frame from bowing when the screws are fixed. Position multiples along the sides and top.

*Use a pen or a small thin implement to push the packers into place.*

- c** Open the window to expose the internal frame, the frame is not fixed in position and will require supporting. Along all four sides pre-drill three holes. Fill the screw holes with clear silicone (**No. 36**) and then fix the UPVC window frame (**No. 39**) to the window frame and the cill using 70mm screws.

- d** Seal around the UPVC window frame, using the colour matched silicone (**No. 37**) apply a bead around both sides and the top of the frame. Be careful to apply a neat line which runs between the UPVC and timber frame.

**12x70mm Screws**

**Important:** Pre-drill before fixing screws.

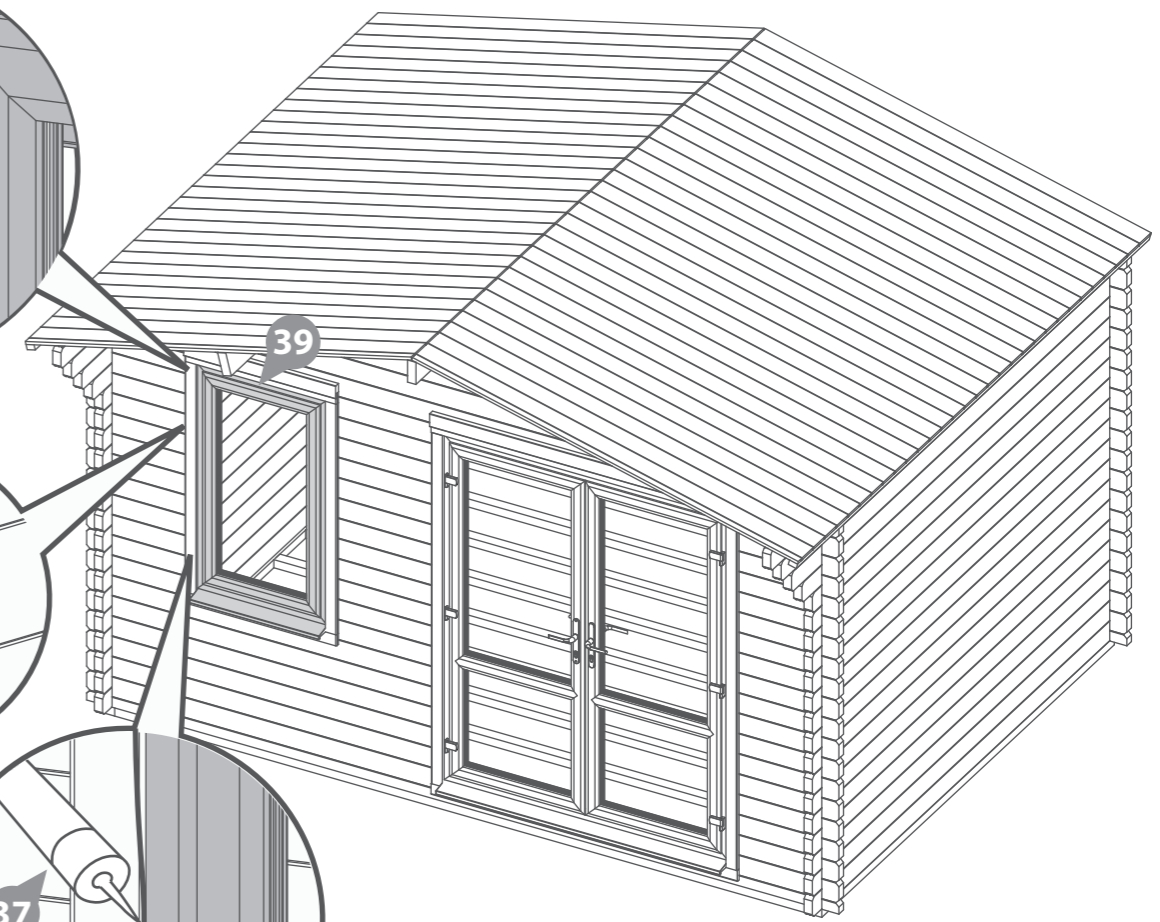
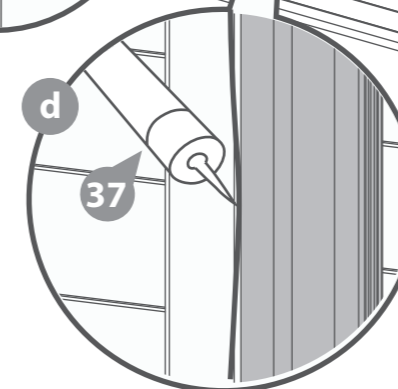
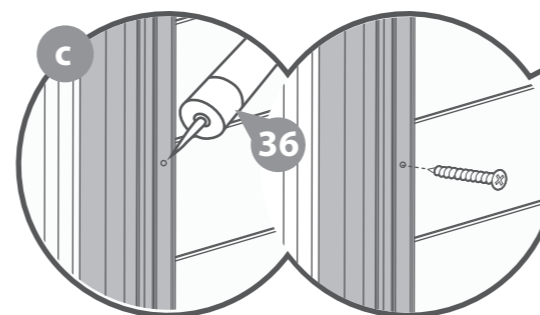
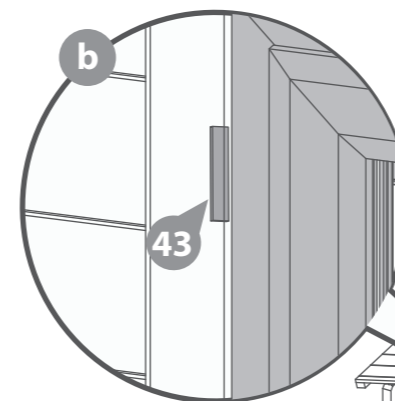
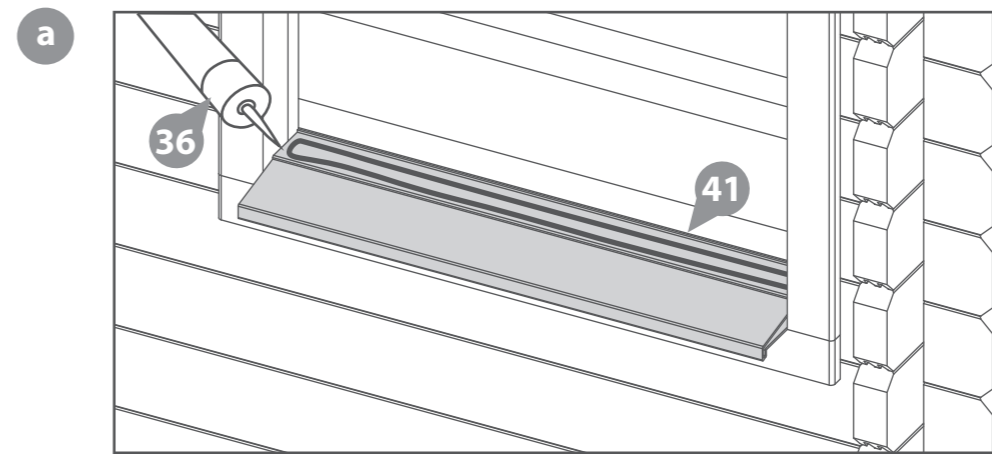
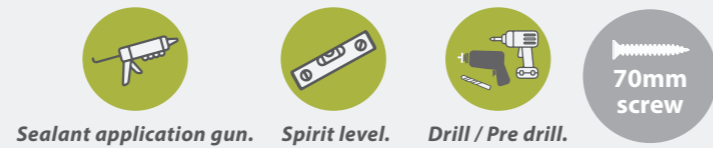

**Step 20**

**Parts Needed - No. 28 QTY 2  
No. 43 QTY 1**

**a** Internally on the UPVC doors (**No. 26**) there is beading attached which holds the UPVC Panel (**No. 28**) in place once fitted. Remove the four pieces of beading, you may need to use a scraper between the beading and the frame to prise them off.

**b** The UPVC Panel (**No. 28**) is slightly smaller than the opening. Add packers (**No. 43**) along the opening, these raise the bottom of the panel up and even out the tolerance gap above and below. Place the UPVC Panel (**No. 28**) into the opening on top of the packers. Add a packer (**No. 43**) at the top of the panel the same thickness as the bottom.

**The UPVC Panel will be unstable until the four pieces of beading have been re-fitted.**

Once the desired packers are in place, ensure the UPVC Panel sits centrally side to side as well as top and bottom.

**c** Take the top piece of beading, starting in one corner gently refit the beading using a small rubber mallet, working from one side to the other.

**Take care to only touch the beading with the mallet.**

Before refitting the bottom piece of beading ensure the packers will not obstruct, move them towards the front of the door frame. Then refit in the same way the top piece was fitted, working from one corner to the other.

Refit the two pieces of beading which run down the sides, starting in the top corners and working down to the bottom.

Repeat the same process for the second door.

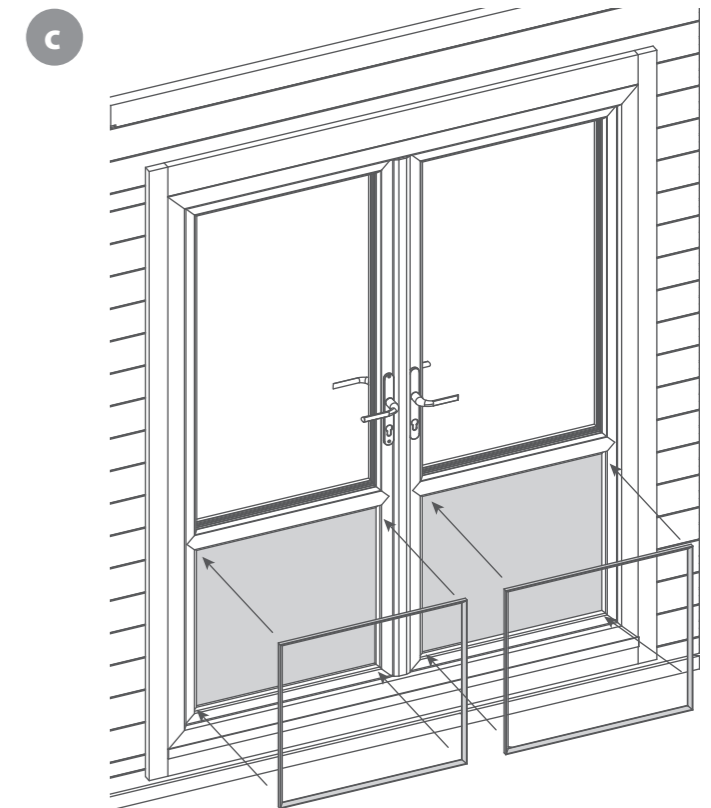
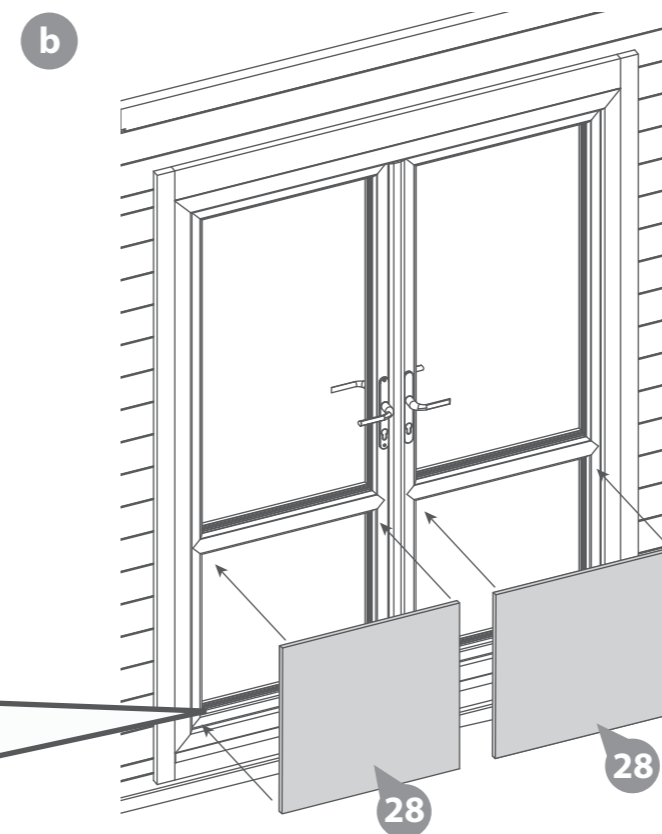
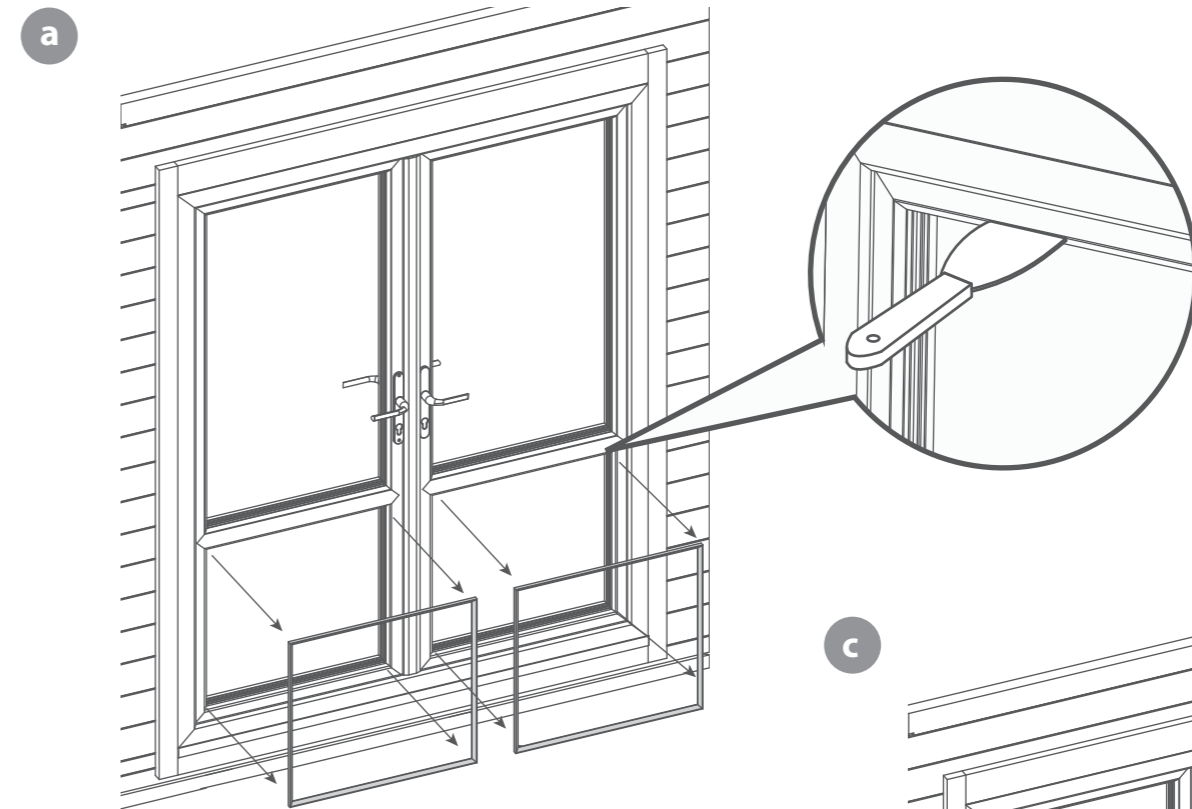
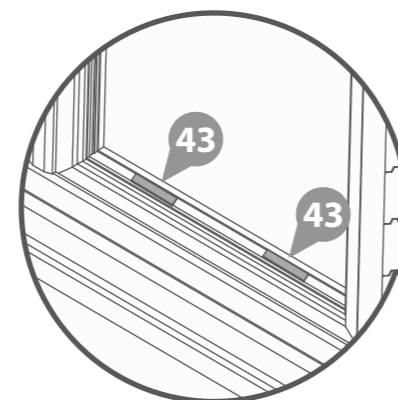

**Step 21**

**Parts Needed - No. 27 QTY 2**  
**No. 40 QTY 1**  
**No. 43 QTY 1**

**a** Internally on the UPVC doors (**No. 26**) there is beading attached which holds the glass (**No. 27**) in place once fitted. Remove the four pieces of beading, you may need to use a scraper between the beading and the frame to prise them off.

**b** The glass (**No. 27**) is slightly smaller than the opening. Add packers (**No. 43**) along the opening, these raise the bottom of the glass up and even out the tolerance gap above and below the glass. Place the glass (**No. 27**) into the opening on top of the packers. Add a packer (**No. 43**) at the top of the glass the same thickness as the bottom.

**The glass will be unstable until the four pieces of beading have been re-fitted.**

Once the desired packers are in place ensure the glass sits central side to side as well as top and bottom.

**c** Take the top piece of beading, starting in one corner gently refit the beading using a small rubber mallet, working from one side to the other.

**Take care to only touch the beading with the mallet.**

Before refitting the bottom piece of beading ensure the packers will not obstruct, move them towards the front of the door frame. Then refit in the same way the top piece was fitted working from one corner to the other.

Refit the two pieces of beading which run down the sides starting in the top corners and working down to the bottom.

Repeat the same process for the second door and the window, using the window glass (**No. 40**).

**Following the door installation if you have any issues with the doors catching or not opening and closing smoothly, see pages 26 - 29 for adjustment advise.**



Rubber Mallet.



Scraper

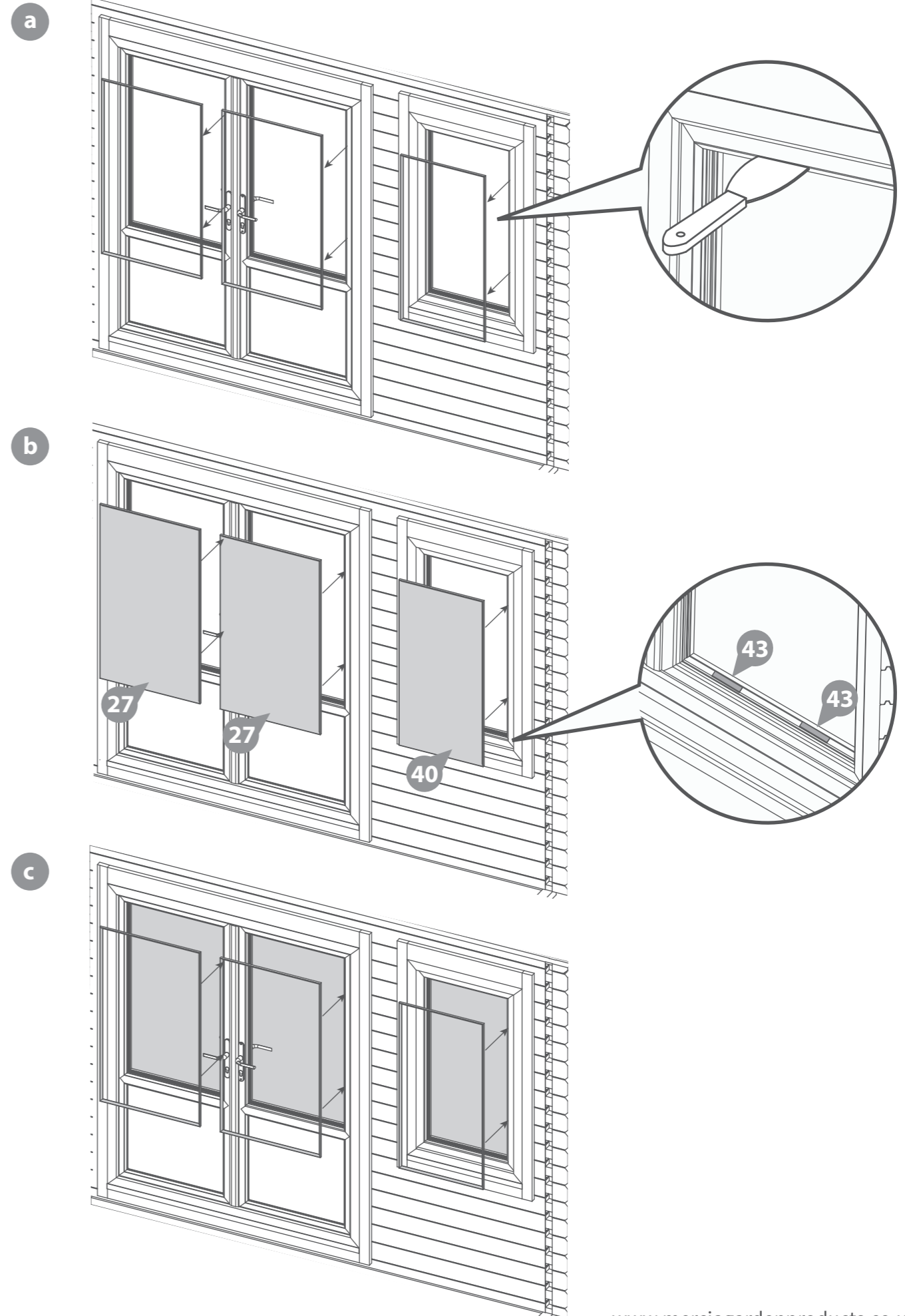

**Step 22**

**Parts Needed - No. 17 QTY 35**

- a** Place the first floor board (**No. 17**) inside the building flush to the log board on one side. Continue adding the floor boards (*internally*) making sure to interlock each individual board.

You have been issued with 35 floor boards, but in reality you may only need to use 34.

**\*Do NOT secure the boards until the last board has been measured and cut.**

- b** Once a full board can no longer fit, measure the gap between the bottom of the tongue (*on the last board placed*) and the log board. Ensure to measure at multiple points along the board for added accuracy.

Using a straight edge, mark out the measurement onto the last floor board (**No. 17**), saw along the length and remove the excess. Mark the final board 2mm under the measurement; This will allow the timber to expand and contract correctly.

Once all the floor boards are in position, secure each board into position using 8x40mm screws per board.

**\*\*\*Please Note:** Ensure to screw through each of the floor boards into the floor bearers.

**280x40mm Screws**

**Important:** Pre-drill before fixing screws.

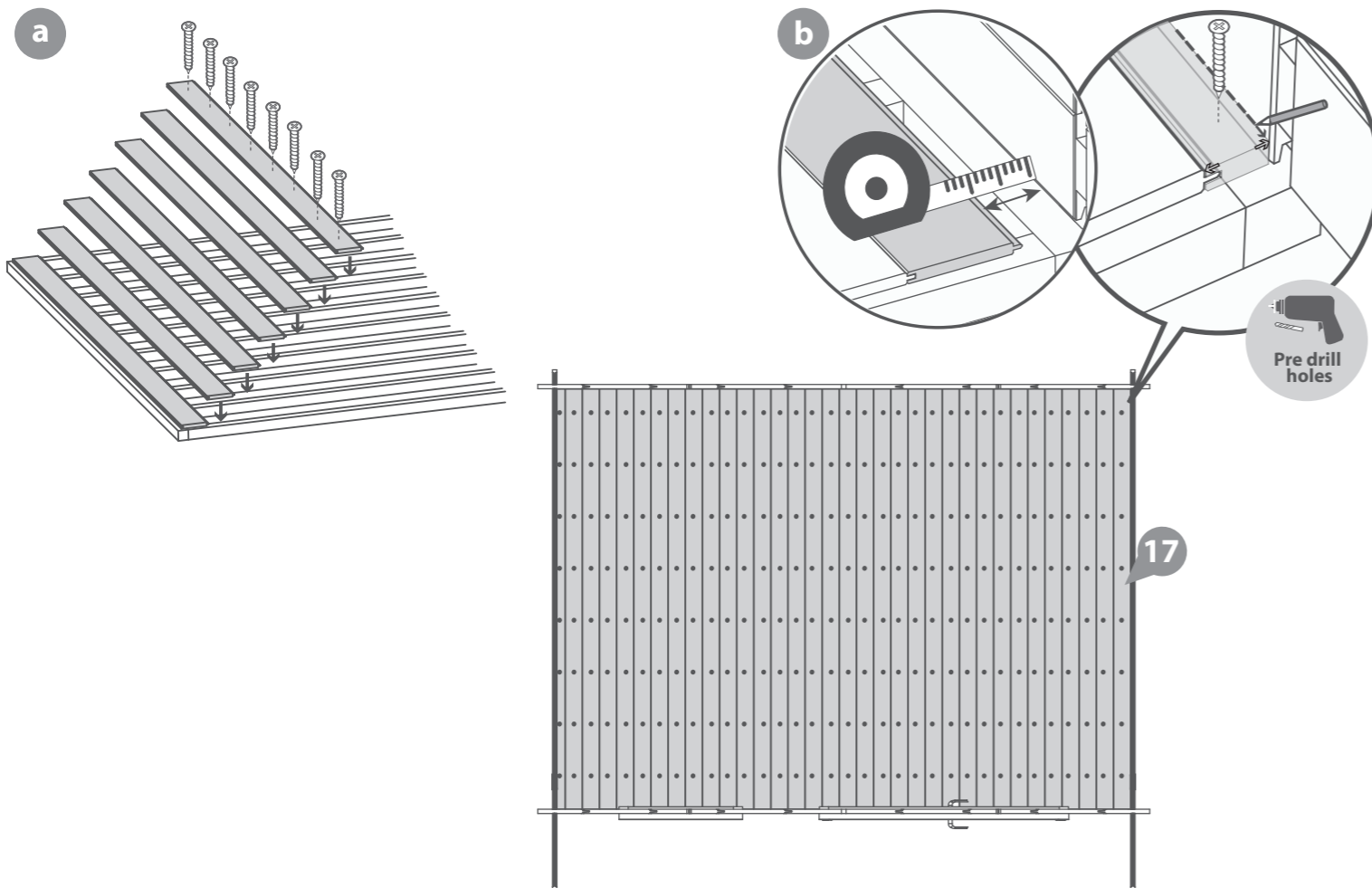

**Step 23**

**Parts needed - No. 21 QTY 5**

Inside the building place the closure trim (**No. 21**) against the boarding and align with the roof as shown in the illustration.

**\*Measure and cut the closure trims to fit the internal space.**

Once in position fix each trim into place by pre drilling a pilot hole and using 6x30mm screws per trim, equally spacing them along the face of the board.

**30x30mm Screws**

**Important:** Pre-drill before fixing screws.

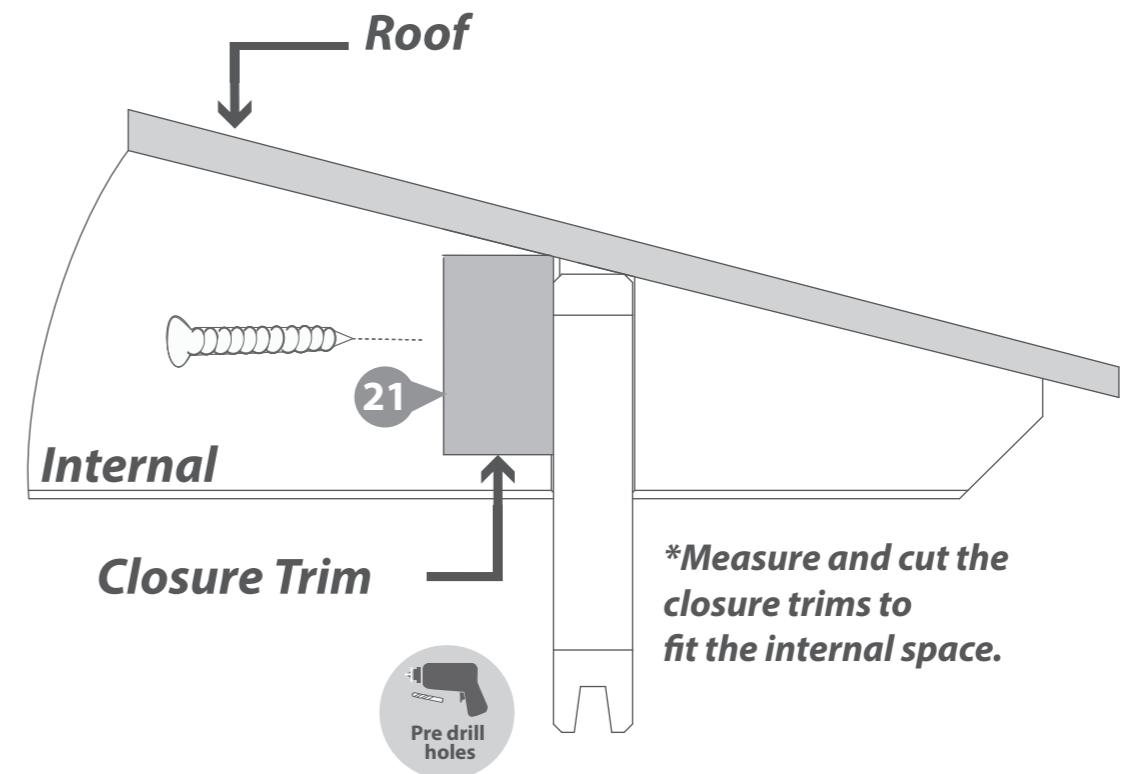

**\*Measure and cut the closure trims to fit the internal space.**



**Step 24**  
Parts needed - No. 21 QTY 6

Once the floor has been laid, arrange the closure trim (**No. 21**) around the outside edge of the floor (**internally**), measure and cut down accordingly to best match the internal space.

Secure each trim section into place using 6x30mm screws spaced equally along the board as shown in the illustration.

**\*Do NOT fix the closure trim to the floor boards.**

**36x30mm Screws**  
**Important:** Pre-drill before fixing screws.

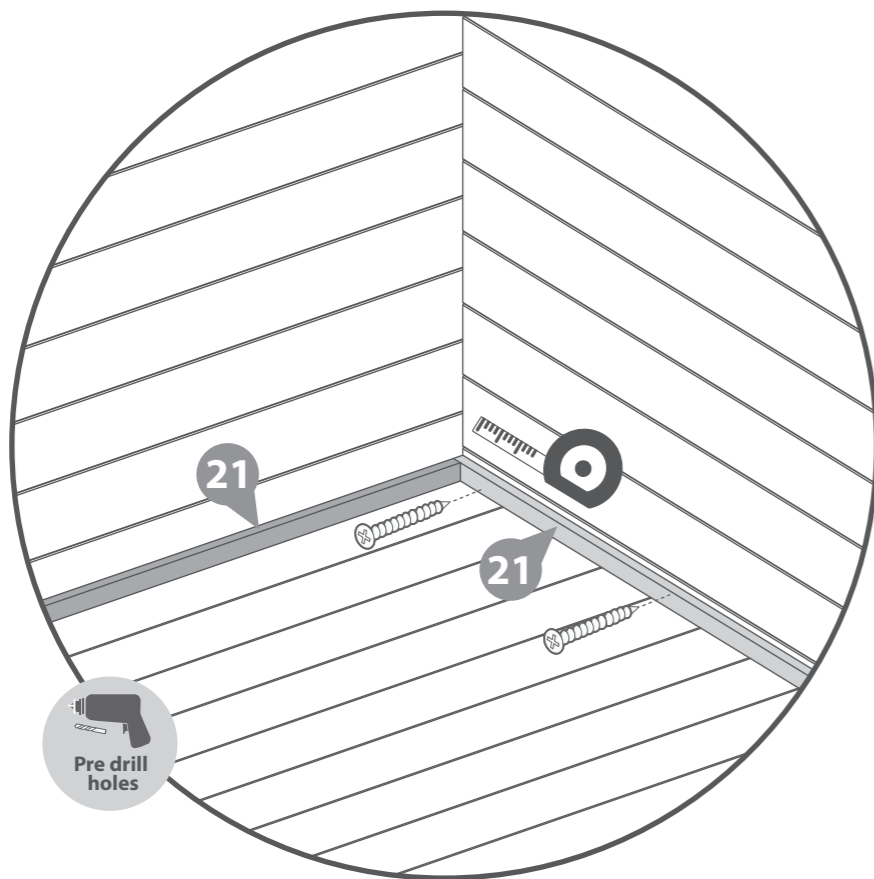

**Step 25**  
Parts needed - No. 24

Cut the felt (**No. 24**) into five strips measuring: **3500mm (L) X 1000mm (W)** and lay onto the roof in the order shown in the illustration.

**\*Ensure there is approximately 50mm of overhanging felt each side and the sheets overlap by 50mm.**

Once the felt is laid out, fix to the roof using felt tacks at 100mm intervals.

**250 x Felt Tacks**

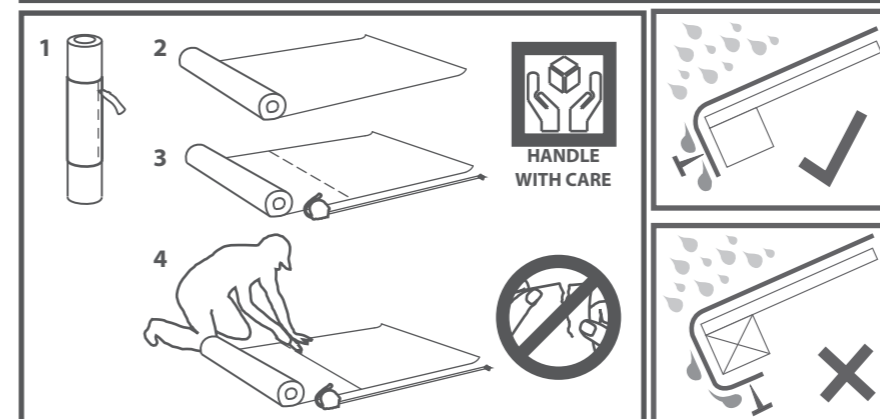
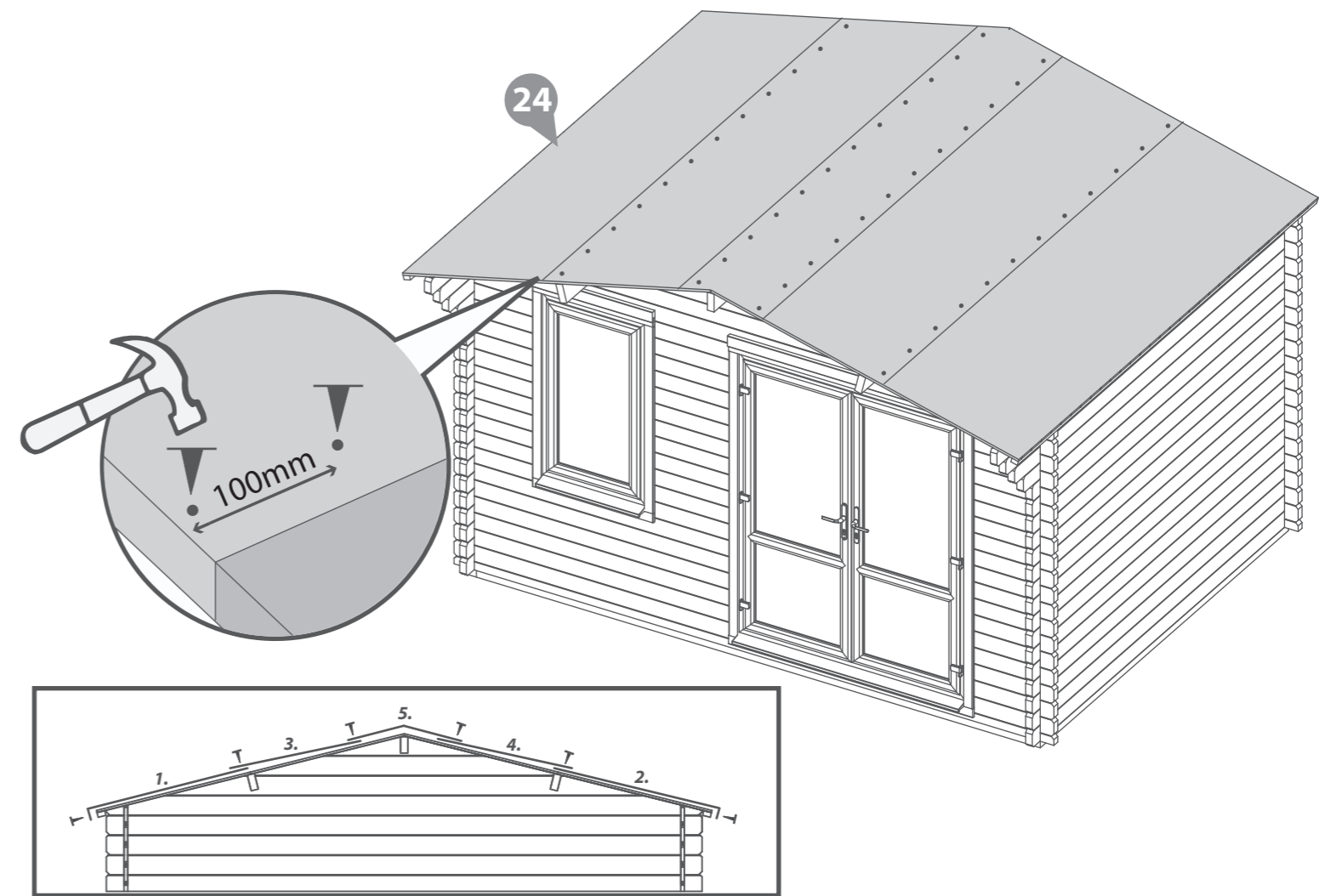

**Step 26**

**Parts Needed - No. 35 QTY 1  
No. 42 QTY 1**

Attach the Rain Guard (**No. 42**) to the Window frame, ensuring to position the rain guard directly above the window, flush to the underside of the top framing, as shown. Make sure the rain guard is positioned centrally. Fix in place using 3x70mm screws.

Attach the Rain Guard (**No. 35**) to the Door frame, fixing in place onto the framing above the Door using 4x70mm screws.

**7x70mm Screws.**  
**Important:** Pre-drill before fixing screws.

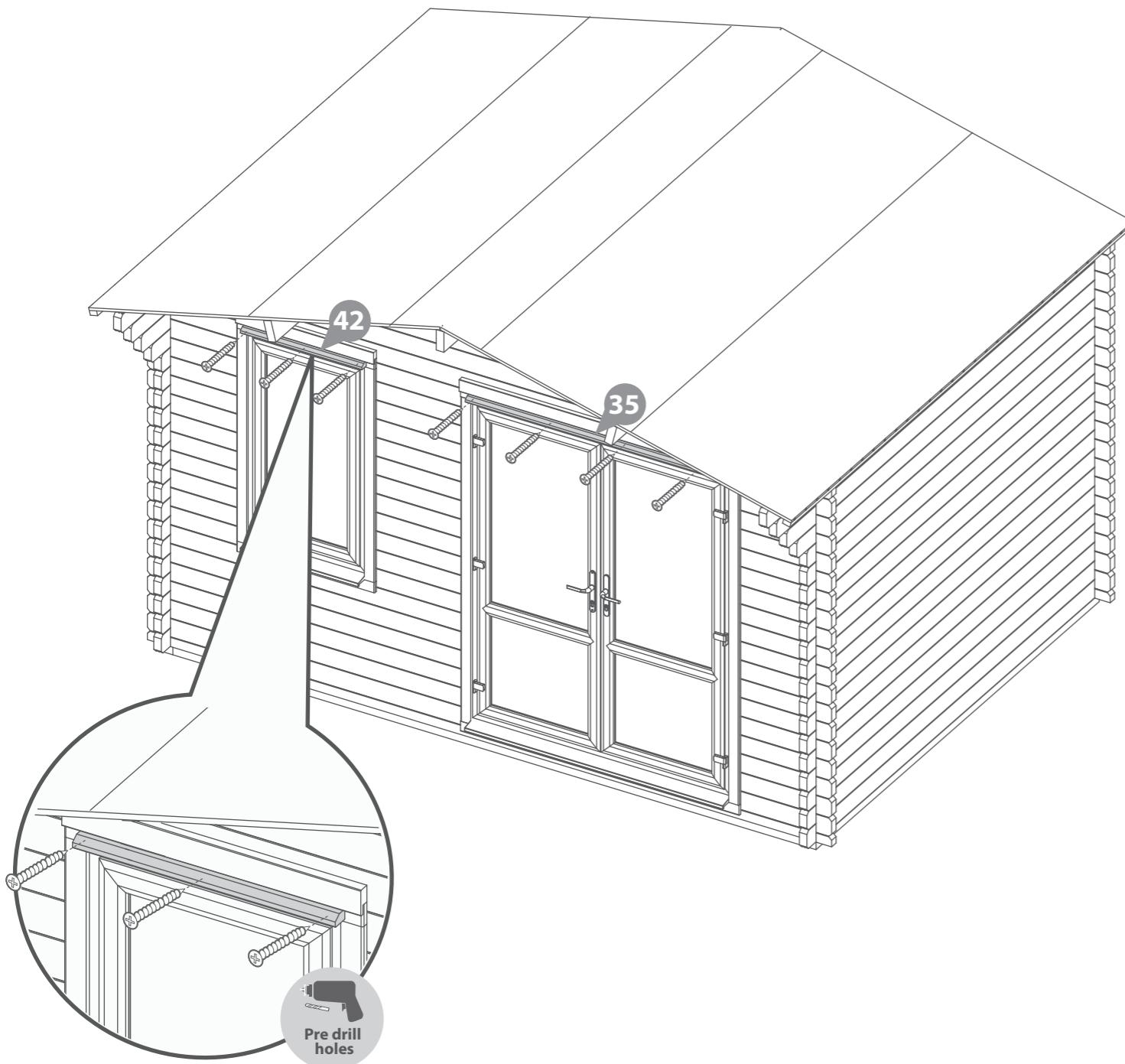
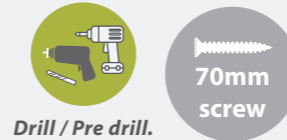

**Step 27**

**Parts Needed - No. 19 QTY 2  
No. 20 QTY 4**

**a** Attach the Fascias (**No. 19**) to the sides of the log cabin (*ensuring to trap the felt in between the fascias*) securing in place by screwing through the Fascia into the Eaves frame behind using 6x40mm screws per Fascia.

Once in place, mark the excess Fascia with a pencil and trim the Fascias to follow the shape of the building, as shown in the illustration.

**b** Locate the Fascias (**No. 20**) to the front and back of the log cabin (*ensuring to trap the felt in between the fascias*) and secure in place using 3x40mm screws per fascia, screwing through the Fascia in to the Eaves frame, Purlin or log board behind.

Once in place, repeat the above method to trim the fascias to follow the shape of the building.

**Ensure the fascias at the back of the log cabin sit level or lower than the felt to allow water to run off.**

**24x40mm Screws**  
**Important:** Pre-drill before fixing screws.

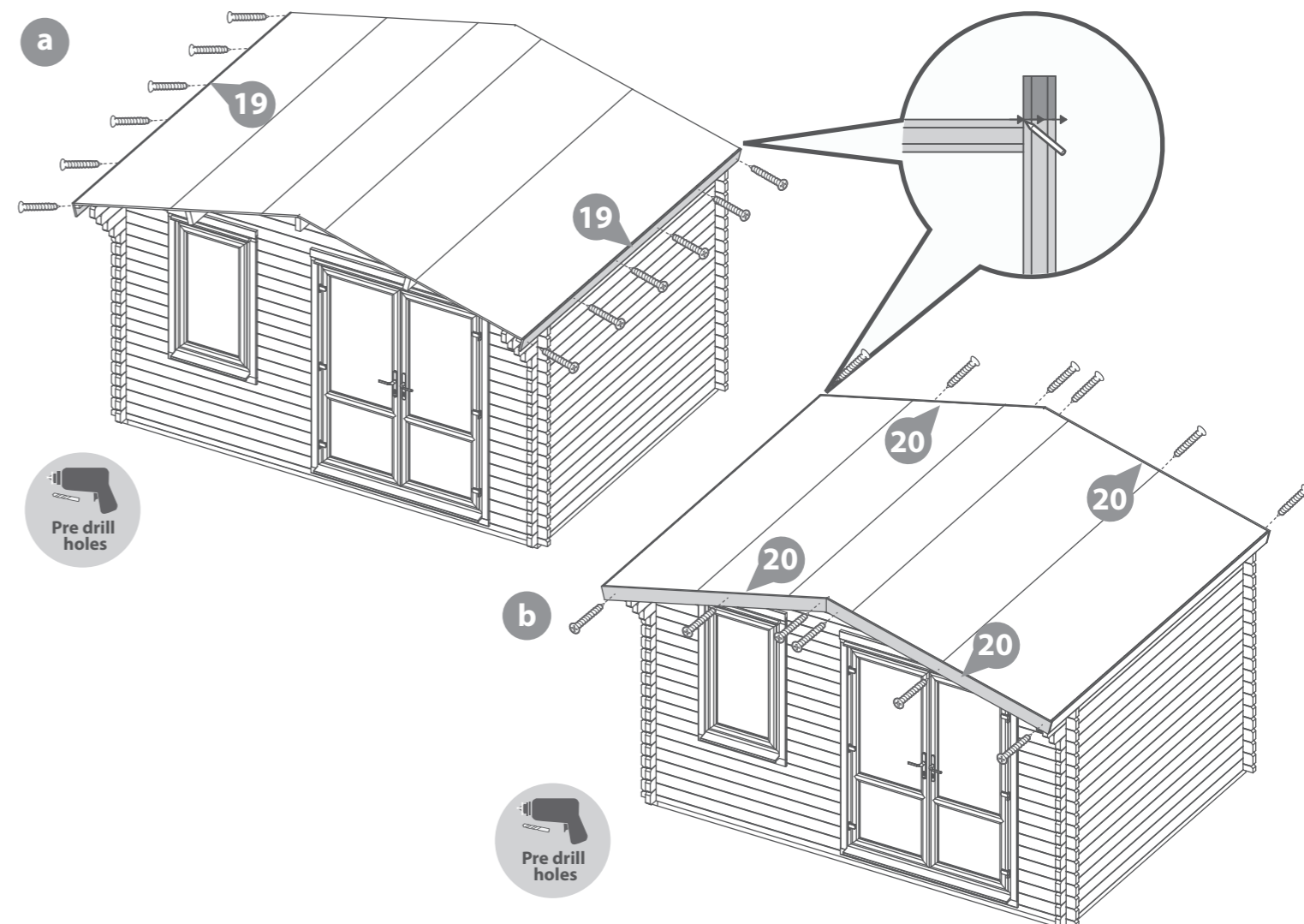



**Step 28**

**Parts needed - No. 22 QTY 8**

Arrange the storm braces (No.22) around the building (*internally*), placing two storm braces per wall.

**\*Ensure the storm braces are secured at the highest point possible on each side.**

Fix in place using 2x90mm bolts per brace, making sure the washer & nut are tightened from the outside of the building.

The storm braces will need to be altered during the buildings life as the moisture content within the log boards changes. The boards will expand during periods of high moisture (Winter) and shrink during periods of low moisture (Summer.)

**\*\*Storm braces are required to be adjusted during changes in humidity to allow the building to expand and contract. To do this, periodically loosen the bolts, adjust the storm brace position and re-tighten.**

**\*\*\*Important: Ensure each bolt is tightened using a washer so as not to damage the log boards.**

**16x90mm Bolt Sets**

**Important:** Pre-drill before fixing screws.



Drill / Pre drill.



90mm bolt

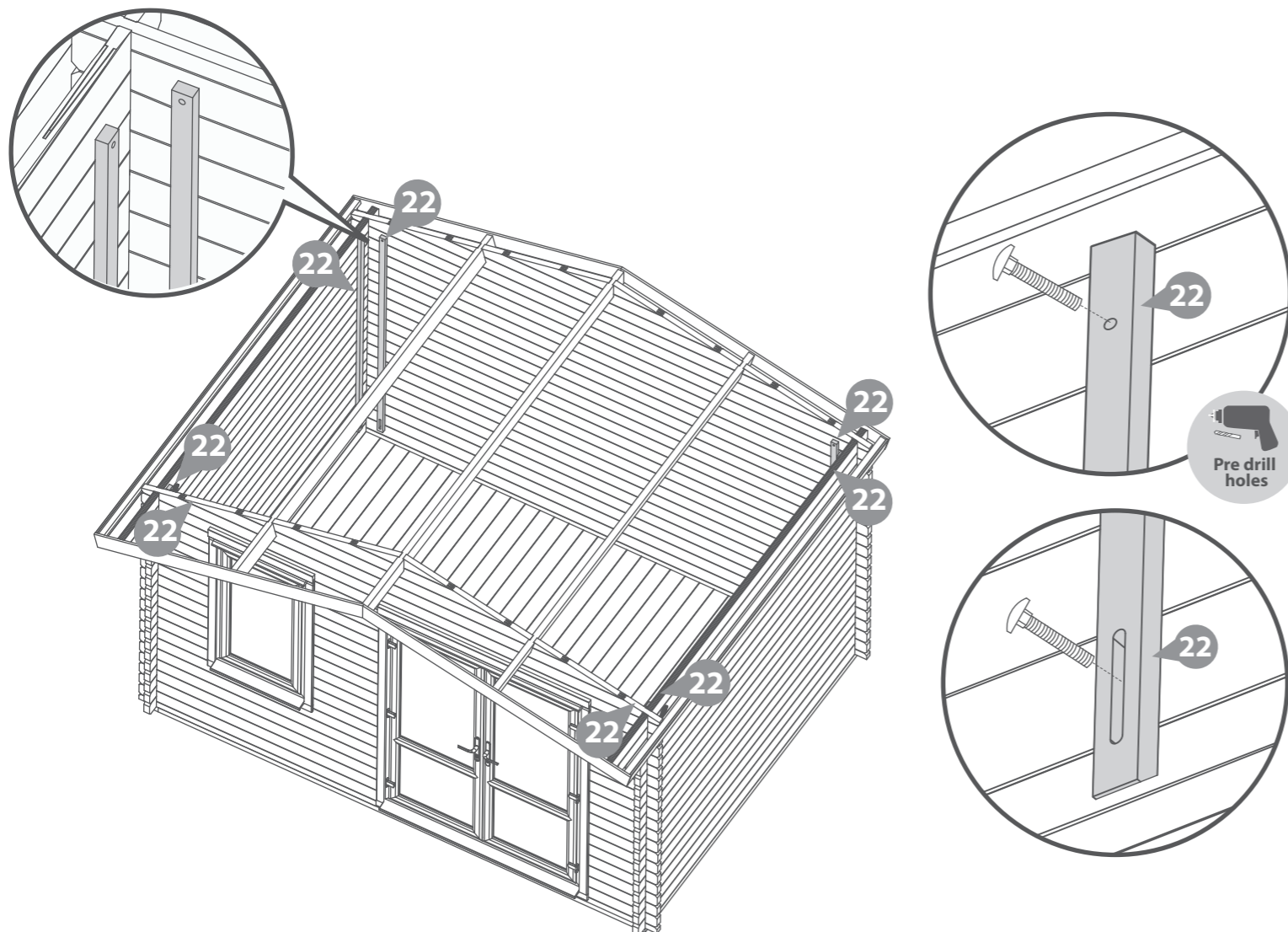

**Step 29**

Once constructed, apply a preserving and a waterproofing treatment to your garden building as soon as possible. This will help to protect your building and prevent decay.

See page 24 for a full guide and instructions.



Apply treatment.



Timber preservative treatment



Treatment mixing stick.



Paintbrush/sprayer/roller.

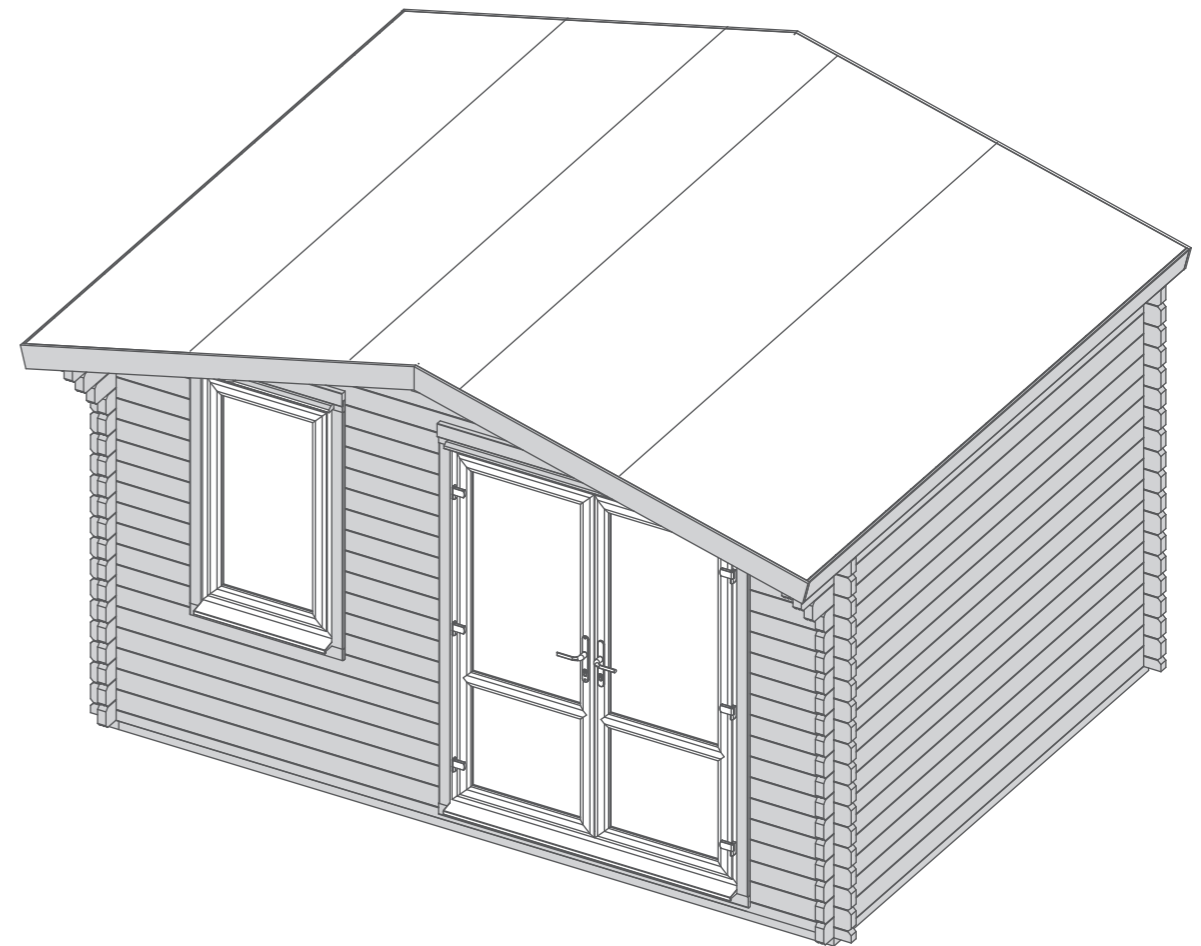

**LEAVE US A REVIEW...**



Want to share your experience with us? Leave us a review on Feefo, TrustPilot or Google.

Your reviews help other people find and trust our business, as well as helping to play an important role in our growth and improvement!



## TREATING YOUR GARDEN BUILDING

Preservation of wood that's outdoors is vital. A little early care will help protect your garden building, improve its appearance and ensure maximum longevity. Insects, moisture, salt, and changing weather can have dramatic effects on the stability and appearance of your garden building. Once your building is installed, you've checked it over and you're happy with it, you can take a few basic precautions to prepare it for the elements. Treating your garden building helps prevent decay and, by repelling water, discourages the growth of moulds and fungi that could jeopardise the structural integrity of the wood.

**Dip Treated buildings** - Require a preservative treatment to protect against rot and decay and a waterproof treatment to prevent water ingress  
**Pressure Treated buildings** - Require a waterproof treatment to prevent water ingress  
**Log Cabins/Insulated Garden Rooms** - Are supplied untreated and require a preservative and waterproofing treatment.



### ANY QUESTIONS?

Scan the QR code to contact us via our customer portal.

To apply a preservative and water proofing treatment (pressure treated products do not require a preserver), follow the manufacturer's instructions but in principle, stick to the following steps:

- ✓ Weather permitting, ensure to treat your garden building within 14 days of installation.
- ✓ Wear latex or rubber gloves, eye protection and (if spraying) a mask.
- ✓ Prepare the wood, by sanding down any ridges or inconsistencies in the wood, smoothing out knots and end-cuts.
- ✓ Choose a dry day to treat your garden building. If you're spraying rather than brushing paint on, avoid a windy day.
- ✓ Be sure you can safely reach all the sections you need to paint - and if you need a ladder, make sure it's safely positioned before climbing. Lay dust sheets around to avoid paint splatters on your base or surrounding plants.

- ✓ Tape around windowpanes to avoid smears when you're painting the frames.
- ✓ Keep pets and small children out of the way. The last thing you want is to have fur on your garden building paint, or little painted footprints all over your garden and home.
- ✓ Fill any gaps in the building's body with caulk or wood filler to prevent water and draughts getting in. Silicone based caulk is flexible and will move with the timber when temperature and humidity change. Allow to dry completely before treating. A handy tip for finding gaps is to go into your garden building and look for light leaking through joints and frames. If light gets in, then so will water.
- ✓ Liberally apply at least two coats of the treatment products with a brush or spray, taking care to allow the first coat to completely dry before applying the second.
- ✓ Make sure the solution permeates the whole of the surface area, especially around natural cracks, end cuts and nail/screw holes.



APPLY WOOD TREATMENT  
**IMMEDIATELY**  
AFTER ASSEMBLY

PLEASE SCAN HERE TO  
SEE TREATMENT VIDEO:



## 1 Perimeter

Check around the perimeter of your product to ensure there are not trees or plants that are in contact with or overhanging the building. This can affect airflow and overhanging trees, or branches can damage the roof, it is advised to keep plants at a distance.

## 2 Repair

Inspect the interior and exterior of the product to look for splits, cracks, and holes. Although this is a natural occurrence it can be prevented. A wood filler can be used to close the splits, cracks, and holes.

## 3 Roof

Check your roof regularly for tears, splits, damaged wood and fallen debris. If you notice any of this immediate repair is critical.

## 4 Doors & Windows

Expansion and contraction can cause doors and windows to stick or become difficult to open. Small adjustments to the hinge position can be made to the doors and windows to allow free movement.

## 5 Oil

Hinges can seize up over time, apply lubricant to the hinges and locks annually.

## 6 Screws & Bolts

It is advised to check all screws and bolts and tighten any loose you might find. For log cabins specifically the storm braces will require loosening. During humidity and temperature changes (seasons) to allow expansion and contraction to prevent gaping, twisting, popping, and warping.

## 7 Wash

At least once a year, give the outside of your building a good wash, to remove cobwebs, leaves, or any other dirt that may accumulate on the exterior.

## 8 Airing

Airing your product regularly prevents the build up of condensation which can cause the timber to warp, bow, boards to pop, distortion, rot and mould. Condensation can build up over time or daily, it is caused by a rise and fall in temperature.

Excessive moisture levels within your building can cause water to collect on the roofs, walls and floors internally. Leaving doors and windows open regularly can help combat the natural moisture build up.

## 9 Storm Braces

The storm braces will need to be altered during the buildings life as the moisture content within the log boards changes, altering the braces will help your building expand and contract properly. The boards will expand during periods of high moisture (Winter) and shrink during periods of low moisture (Summer).

Ensure each bolt is tightened using a washer so as not to damage the log boards.

## 10 Clean & Tidy

It is good practice to clean the inside and outside of your product regularly. Clear out the contents, sweep the floor, remove dirt and cobwebs. Check for areas of damp and investigate the cause to remove and prevent future occurrences. Check the ground around your product for build up of debris such as leaves, remove and ensure there is clear ventilation underneath the floor.

### Additional Playhouse Maintenance:

It is recommended that the following checks and maintenance are carried out at the beginning of each season as well as at regular intervals during the usage season.

- Check all nuts /bolts/ screws for tightness and tighten when required.
- Check for movement / opening of wood giving rise to protrusion of nail heads and tips.
- Check hinges.
- Replace defective parts in accordance with the manufacturers instructions.
- Check any crossbeams, suspensions and anchors.
- If a swing is included; check the swing seat, chains and ropes.

**IF THESE CHECKS ARE NOT CARRIED OUT THE ACTIVITY TOY COULD BECOME A HAZARD**

**Problem: Doors catching on the frame - sides.**

If your door is catching on the adjacent door or side frames, your doors need adjusting to the left or right:

- 1 Unlock the doors and open.
- 2 When open, you can see the back of the hinges, (if the doors open outwards this will be inside) where there are two screws inside the hinge. Use a screwdriver to unscrew the screws fully but do not remove. Use a flat head screwdriver to gently release the cover.
- 3 On the front of the hinge, pull open the released cover for each hinge. Repeat for each hinge and close the doors. But don't lock.
- 4 Now the screws inside the hinge can be loosened to make the doors slack slightly. Use a Philips screwdriver to loosen the face on screws slightly (approx half a turn depending) on each hinge.
- 5 Place the Allen key into the central screw and turn - you will see the mechanism move depending on which way you turn. Adjust this screw accordingly depending on which way the door needs to move and do the same for each hinge accordingly.  
*Note: Depending on which way the door is offset (from the top of bottom) depends which way the screw should be turned.*
- 6 Open the doors and check for catching. Check the gap between the door and lock catch is not too large and continue to adjust in the same way as step 5 if needed.
- 7 Once all adjustments are complete, re-tighten the face on screws in each hinge to prevent further movement. Close the hinge covers ensuring they click into place and re-tighten the internal screws.

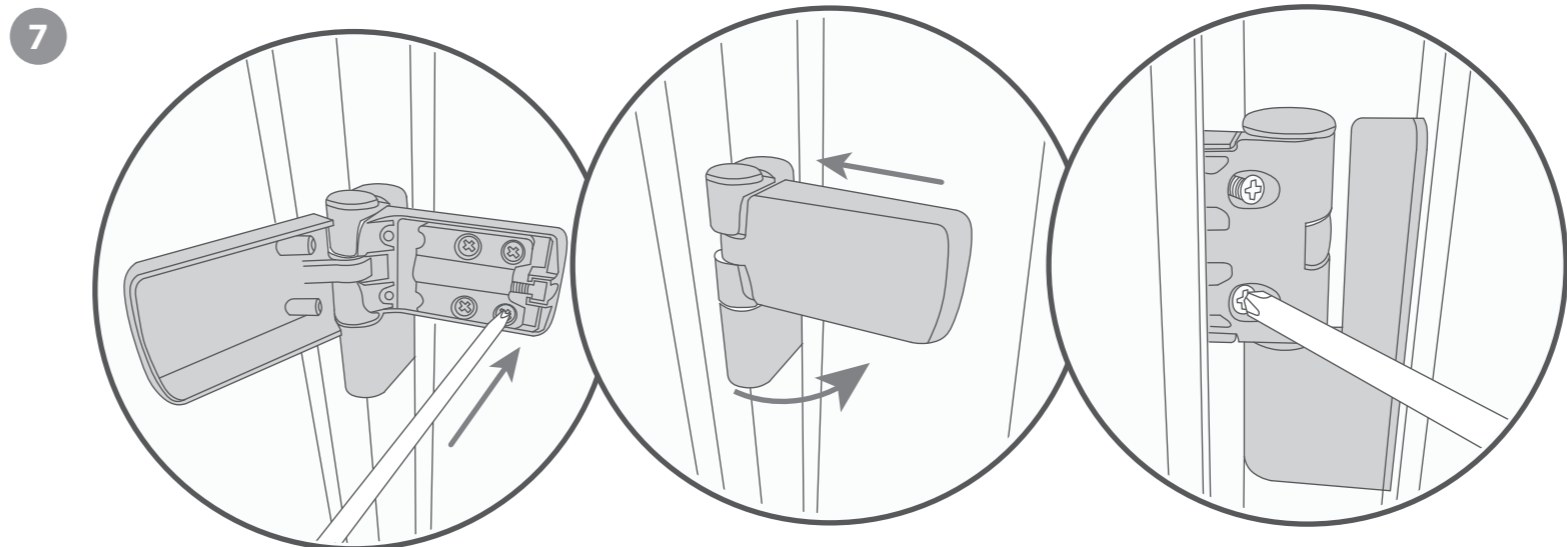
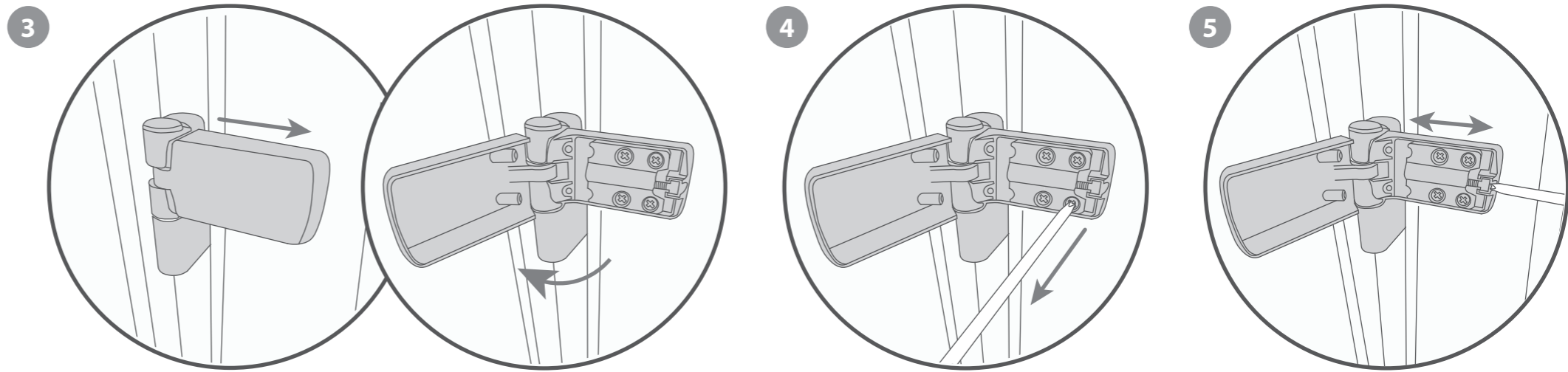
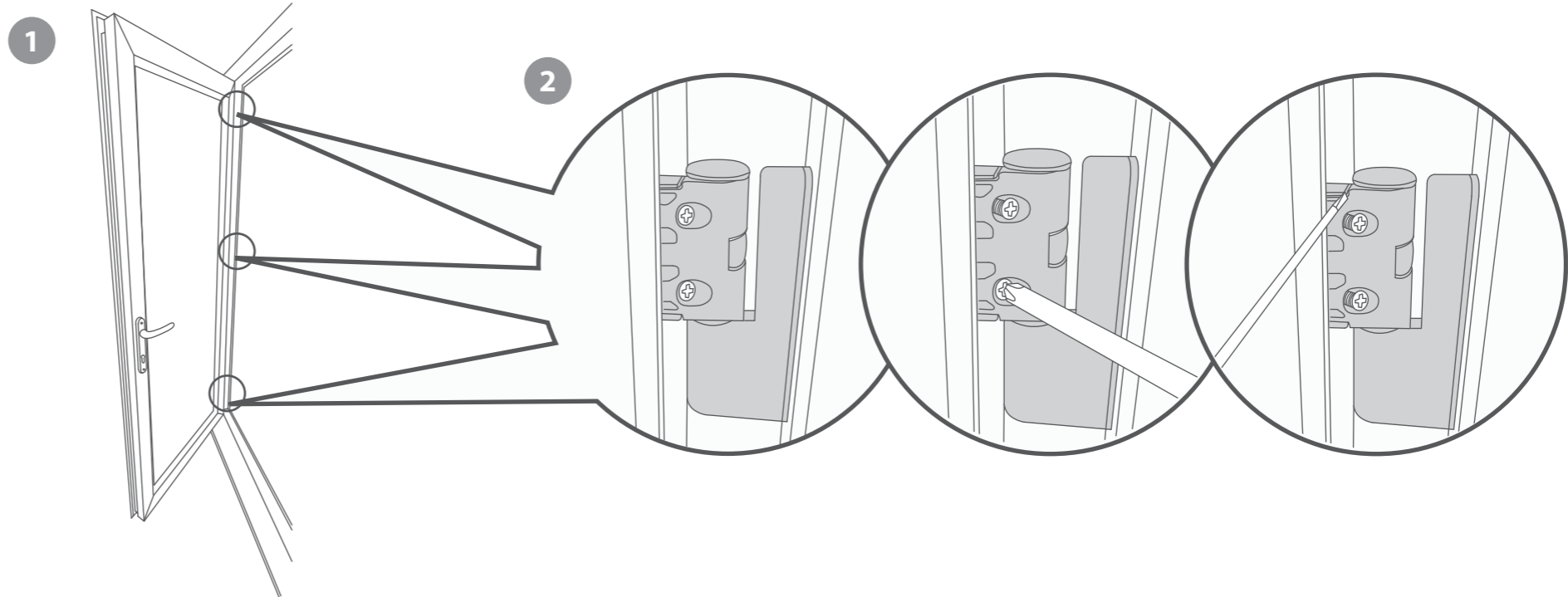



## Problem: Doors catching on the frame - top or bottom.

If your door is catching on the top or bottom frame, your doors need moving up or down.

- 1 Unlock the doors and open.
- 2 On the front of the doors, locate the part of the hinge that is attached to the frame, on the underside there are two small holes.
- 3 Locate an Allen key into the hole closest to the frame, ensuring it catches the thread internally. Turn the key to the left or right to raise or lower your door height. Once you're happy with the height, adjust on each hinge so the weight isn't resting on only one hinge.
- 4 Check the doors open and closes freely and that the lock mechanism still works. If more adjustments are needed, repeat the above steps.

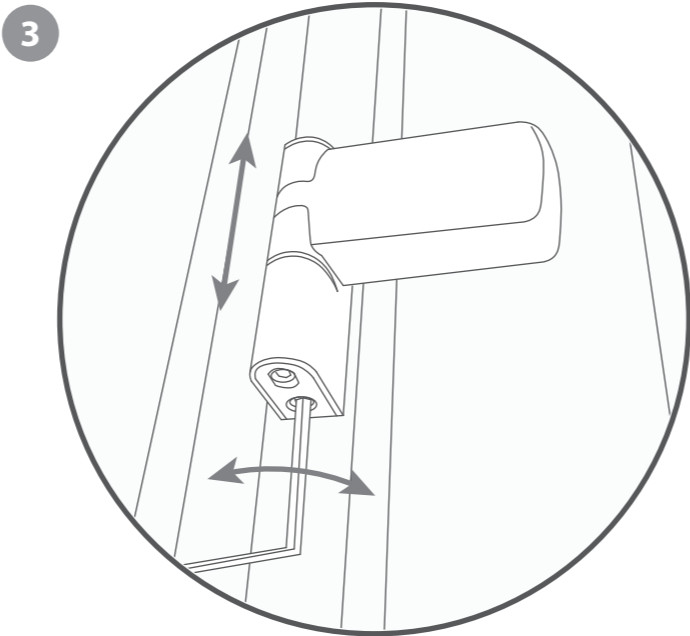
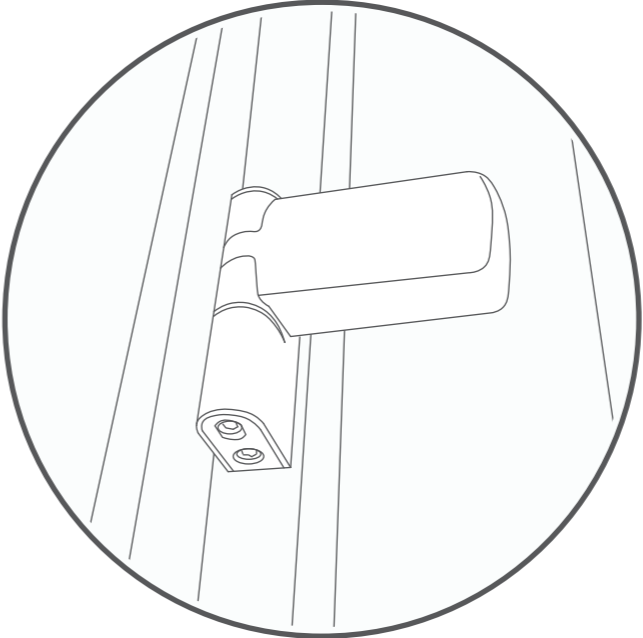
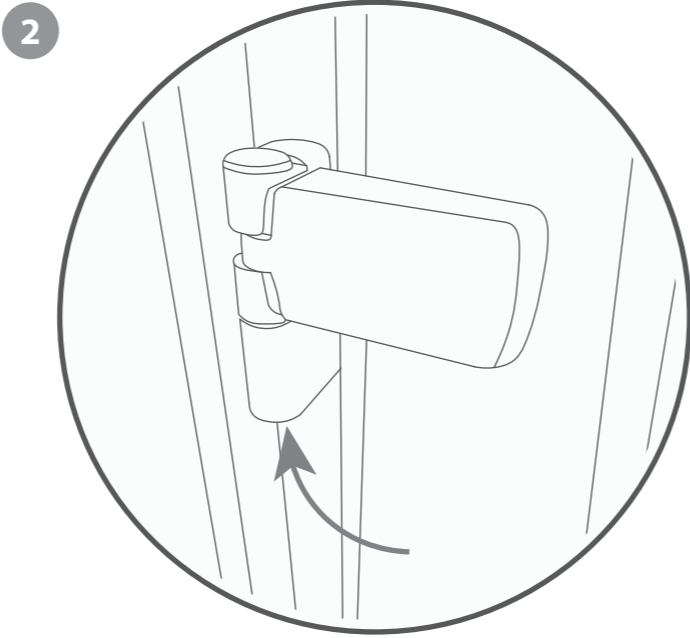

Allen key set.

## Problem: Gaps, draughts, excessive movement between doors and framing:

If your doors are rattling or have excessive movement, the internal latch needs to be adjusted.

- 1 Unlock the doors and open.
- 2 Locate the latch on the inside of the secondary door or framing, with screws above and below it.
- 3 Loosen the two screws slightly - DO NOT fully remove as it is very difficult to get them back in - and see the latch is loosened and able to move more.
- 4 Adjust the latch inwards slightly and re-fix the screws. Check how the door sits / movement and continue to adjust accordingly in the same way until there is no more movement.

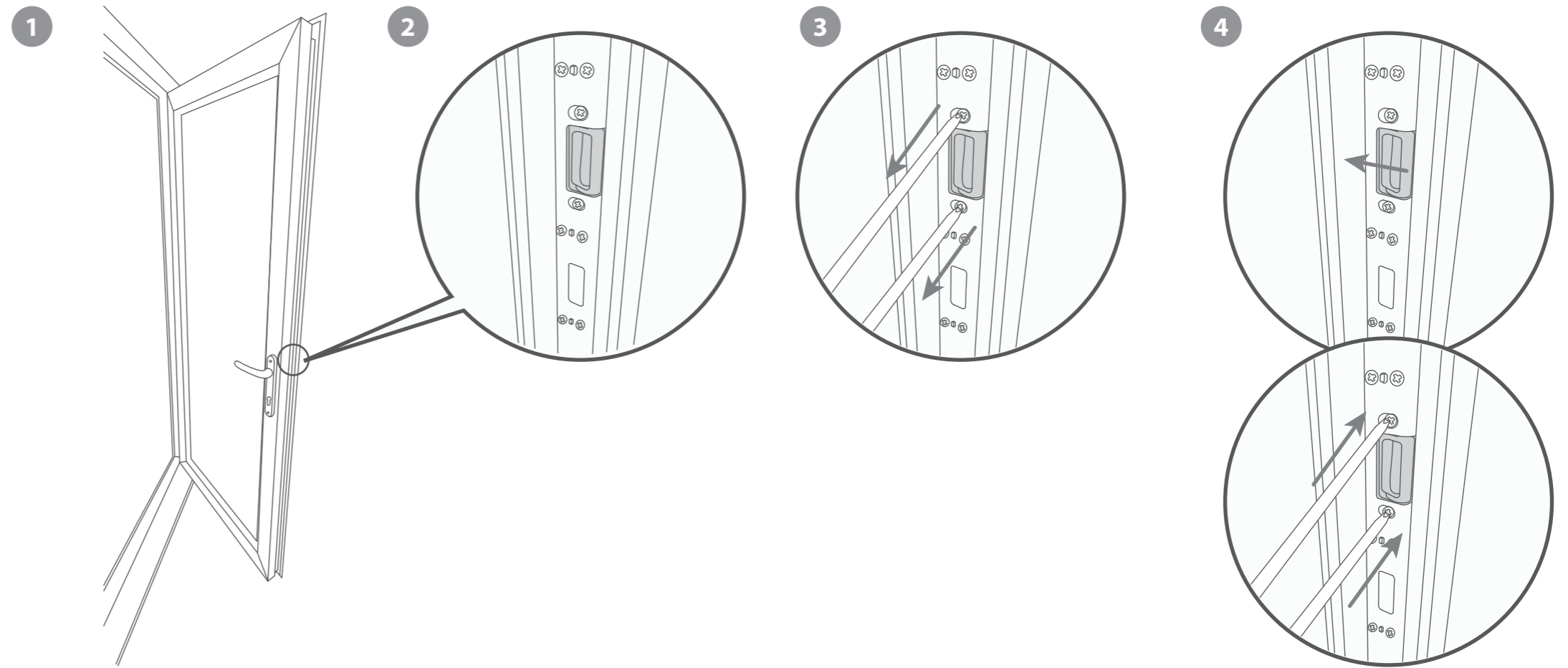

If your doors are rattling or have excessive movement, where the doors sit may need adjusting within the casing.

- 1 Unlock the doors and open.
- 2 Locate the cam mechanism on the inside of the master door - one at the top and one at the bottom.
- 3 Insert an Allen key into mechanism and spin either way. This will move the door forward or backwards in the casing. Do this on the top and bottom mechanism.
- 4 Adjust until you are happy with how the door sits, ensuring it isn't too tight / close to the casing when the door is shut. (If the door is too tight then the handle wont move). Check the door opens and closes freely and the lock mechanism works, if not continue to adjust and check until happy.

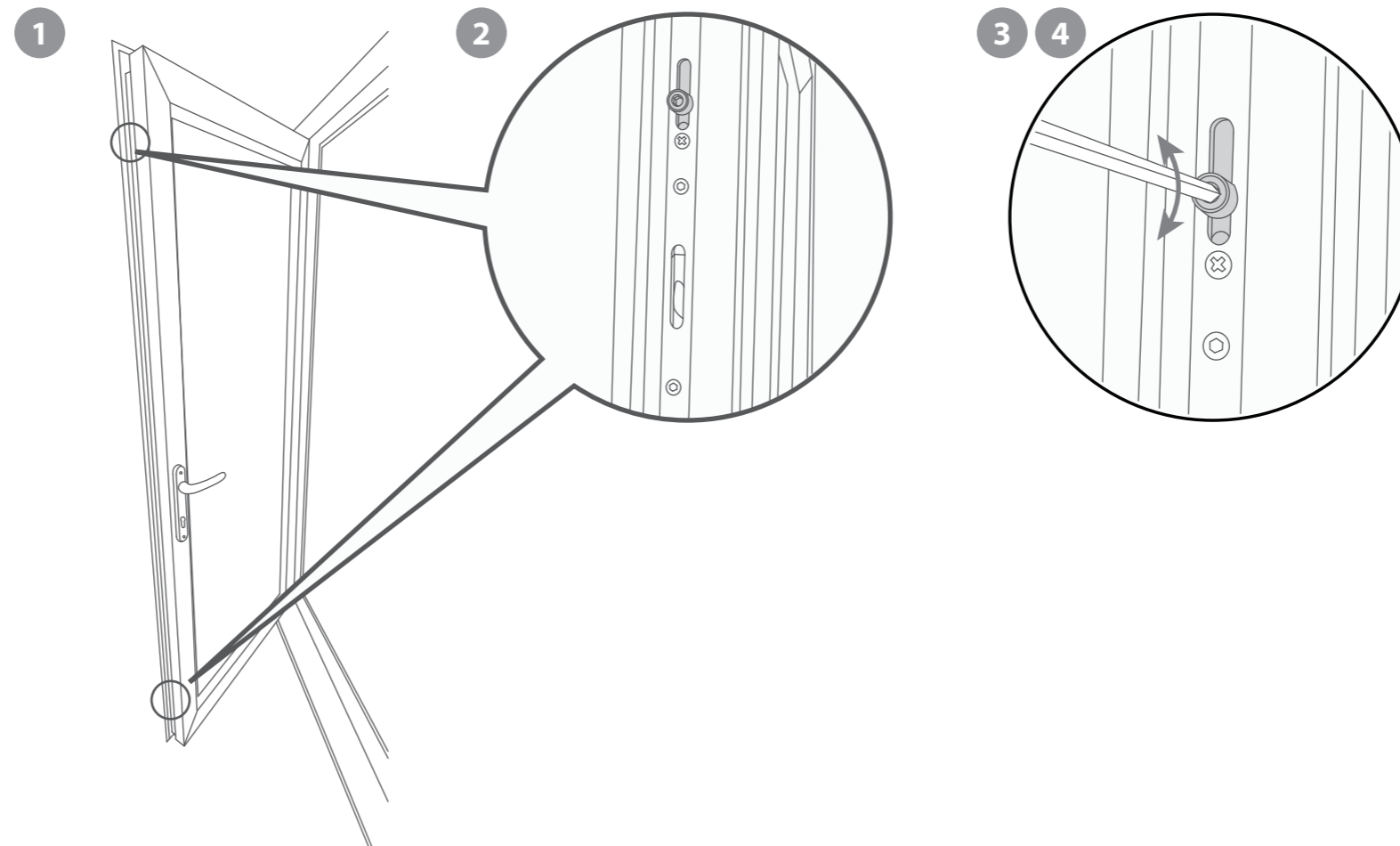

## Problem: Windows not staying open.

If your window is not staying open on its own, you may need to adjust the friction stays.

- 1 Unlock and open the window - ensure to hold window open manually.
- 2 Locate the friction stay on the inside of the window
- 3 Use a screwdriver to tighten the screw by turning clockwise. Repeat on the opposite side of the frame.
- 4 Check to see if the window stays opens - ensure to check at different depths / positions - and continue to adjust if needed.



Philips screwdriver.

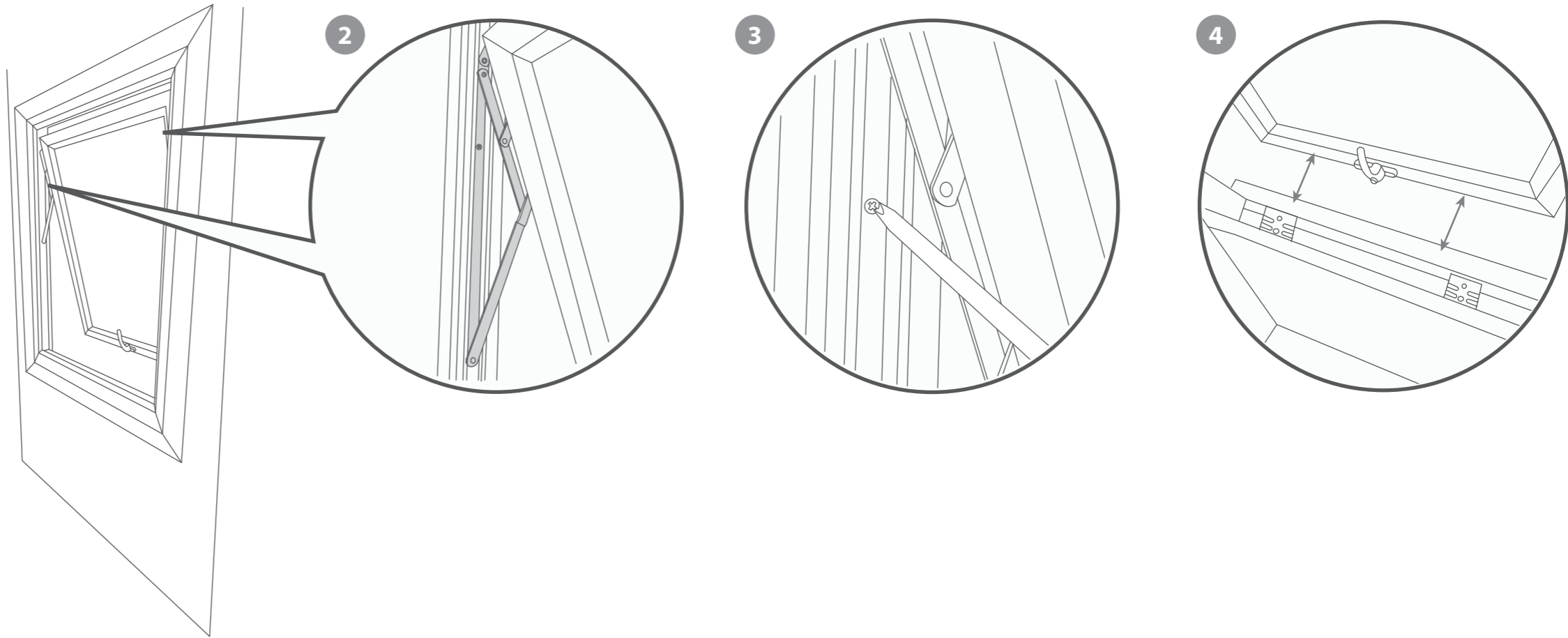

## Problem: Windows catching the lock.

If your window is not catching the lock mechanism, you may need to adjust the lock casement.

- 1 Unlock and open the window - ensure to hold window open manually.
- 2 From the outside, locate the lock on the underside of the window.
- 3 Locate an Allen key into the screw and adjust accordingly - move in or out so it will catch - repeat across all screws.
- 4 Close and lock the window to check if the window latches correctly - adjust if needed.



Allen key set.

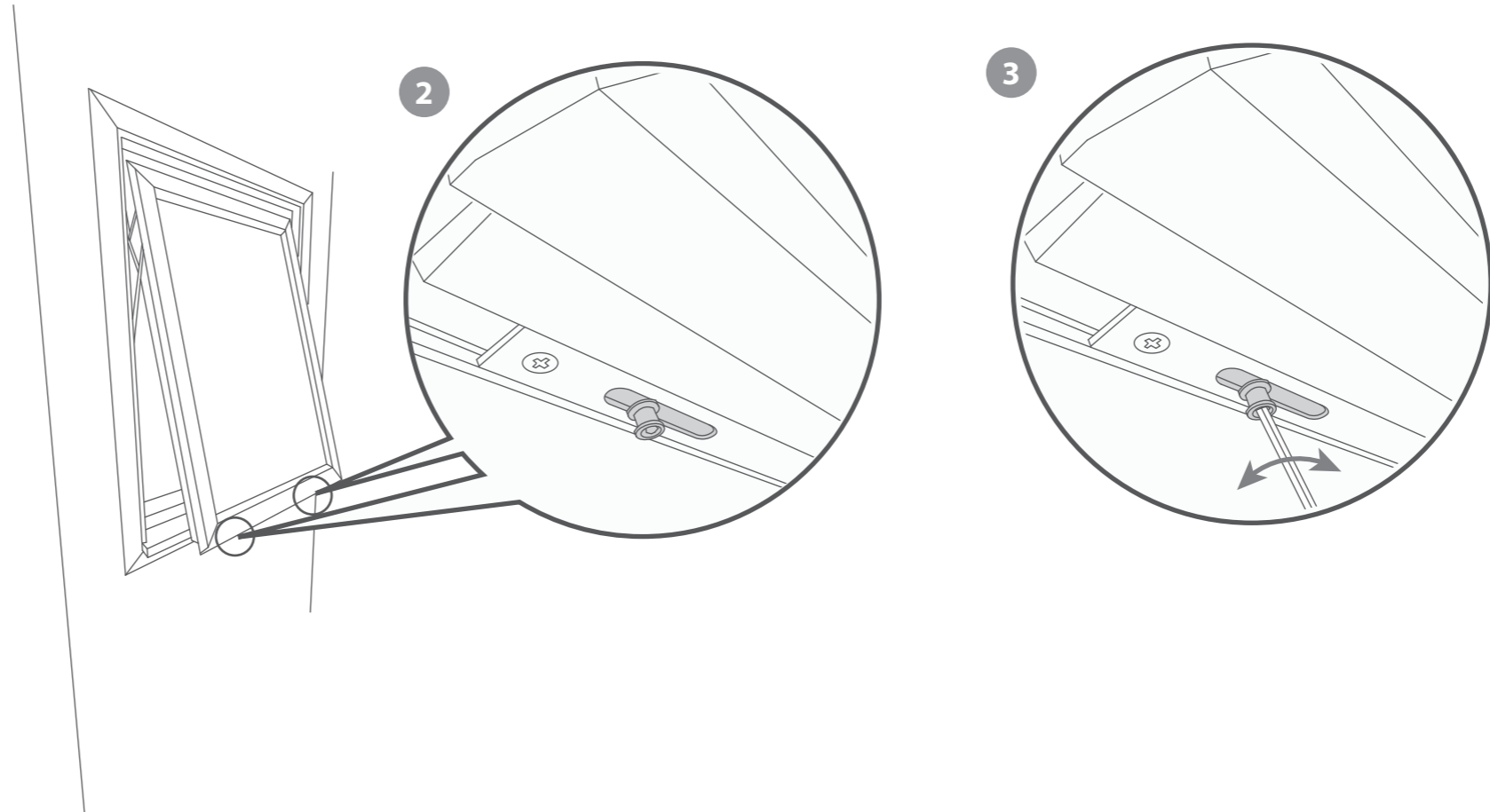



All our garden buildings have been designed and manufactured with care and attention to be the perfect addition to your outdoor space. To ensure you do get the best out of your new garden building and to increase the longevity we advise that you follow the product instructions and our manufacturer's recommendations as detailed below. Thank you for choosing a Mercia Garden product!

## 1 Choosing the most suitable location for your garden building...

A minimum of 60cm should be left around the perimeter of your garden building to allow access for maintenance, annual treatment and to allow air flow around the building.

Where possible you should avoid placing your garden building underneath large trees to prevent the tree causing damage to the building.

## 2 Preparing the base for your garden building...

All our buildings must be built on a firm, level base to ensure the longevity of the building and prevent the wood from distorting. We recommend either concrete, concrete slabs or a wooden base, such as our 'Portabase'.

The base should be slightly smaller than the external measurement of the building, i.e. the cladding should overlap the base, creating a run off for water and preventing water from pooling underneath the building.

We also recommend that the floor of the garden building is a minimum of 25mm above the surrounding ground level to avoid flooding.

## 3 After installation...

Once your garden building has been installed, it will need to be treated within 14 days (weather permitting) and annually to prevent the timber from deteriorating and to waterproof it. This is required to maintain the anti-rot guarantee.

Dip Treated buildings - Require a preservative treatment to protect against rot and decay and a waterproof treatment to prevent water ingress.

Pressure Treated buildings - Require a waterproof treatment to prevent water ingress.

Log Cabins/Insulated Garden Rooms - Are supplied untreated and require a preservative and waterproofing treatment.

We also recommend using a silicon sealant on the inside and outside of the windows as soon as possible after assembly and treatment to fully seal the windows.

Roofing felt/covering should be checked annually and replaced or fixed accordingly.

## 4 General maintenance and wood characteristics

As wood is a natural material it may be affected by the following:

**Shrinkage and warping** - The timber used in the construction of your garden building will have retained some of its natural moisture content. The moisture content of the timber will vary, depending upon prevailing environmental conditions, which will result in the components either naturally expanding or contracting. As the components dry out, shrinkage may occur. A good waterproofing treatment from the start is the best protection to minimise the effect of moisture loss/intake.

In extended periods of very warm weather getting some moisture to the building will help the overall balance. You can do this by spraying it down lightly with a garden hose. In contrast, after snow fall try to remove the snow as best as possible from the roof to prevent moisture intake and to remove the extra weight.

Top tip - using a garden brush will help you to reach the highest part of the building to remove snow and any debris left from bad weather.

**Damp and mould** - During the winter months, cold and damp conditions can result in an increased amount of moisture within your garden building, especially when used infrequently. Condensation can form on the timber and other items stored within your garden building. If left this moisture is likely to cause mould and mildew.

To prevent the build-up of moisture, we recommend leaving the door or windows of your building open from time to time, to allow the fresh air to circulate. We also advise against storing wet or damp items in your garden building as this will also increase the level of moisture in the building. If mould or mildew does start to form within your building we recommend using an anti-mould cleaner to remove it and to prevent it spreading, which if left untreated could permanently damage your garden building.

**Splits, cracks and knots** - You may notice small splits and cracks in some components or holes may appear where knots shrink and fall out. This will not affect the structure of your Garden building however, if you wish to fill them this can be easily done using any good quality wood filler.

**Sap** - is naturally occurring in wood and may appear in some boards of your garden building. If you wish to remove the sap, we advise waiting until it is dry and then using a sharp knife to carefully remove it. If the removal of the sap causes a hole in the timber, we recommend using a good quality wood filler to fill it.

For more handy hints and tips on how to care and maintain your garden building please refer to the MGP Customer Portal at [www.mgplogistics.co.uk](http://www.mgplogistics.co.uk)

### Any further questions?

Contact our  
Customer Service Team via the MGP  
Customer Portal at:  
[www.mgplogistics.co.uk](http://www.mgplogistics.co.uk)

## 1

### Manufacturer's Warranty

All Mercia Garden Products are supplied with a 1 year warranty on all parts against manufacturing defects.

This warranty does not cover movement, warping or splitting of timber products over time.

This warranty will be voided if any of the following occur:

1. The building has been customised or modified/adapted in any way.
2. The person claiming is not the original purchaser of the building.
3. Any damage has been caused by or as a result of misuse.
4. The building has not been maintained and cared for in accordance to our advisories and manufacturer's recommendations.
5. The building has not been treated annually or as per the manufacturer's recommendations, please ensure receipts are kept to validate this claim.
6. The building has not been erected, fitted or installed as per the supplier instructions.
7. The building has not been erected on a suitable sized firm flat, solid level concrete/slab base or placed on pressure treated bearers.
8. The building is or has been placed with 2 feet (600mm) of any obstructions (walls, trees, plants, fences etc.) which can allow moisture to penetrate the timber.
9. The roofing felt has been incorrectly fitted or damaged, allowing water ingress, or has not been properly maintained.
10. Any windows and joints have not been sealed, inside and out, with silicone or other watertight sealant.
11. Any timber has been cut, pierced or drilled without subsequent application of approved cut-end treatment.

## 2

### Anti-rot Guarantee

Mercia Garden Products offer a 10 year anti-rot guarantee on all dip treated (a preparatory treatment) and 15 years on all pressure treated products. This guarantee covers solid timber against rot, decay, blue stain and insect attacks.

To validate the guarantee the building must be treated (as detailed within manufacturer's recommendations) within 14 days (weather permitting) of assembly and annually thereafter.

This guarantee does not cover movement, warping or splitting of timber products over time.

This guarantee will be voided if any of the following occur:

1. The building has been customised or modified/adapted in any way.
2. The person claiming is not the original purchaser of the building.
3. Any damage is caused by or as a result of misuse.
4. The building has not been maintained and cared for in accordance to our advisories and manufacturer's recommendations.
5. The building has not been treated annually or as per the manufacturer's recommendations, please ensure receipts are kept to validate this claim.
6. The building has not been erected, fitted or installed as per the supplier instructions.
7. The building has not been erected on a suitable sized firm flat, solid level concrete/slab base or placed on pressure treated bearers.
8. The building is or has been placed with 600mm of any obstructions (walls, trees, plants, fences etc.) which can allow moisture to penetrate the timber.
9. The roofing felt has been incorrectly fitted or damaged allowing water ingress, or has not been properly maintained.
10. Any windows and joints have not been sealed, inside and out, with silicone or other watertight sealant.
11. Any timber has been cut, pierced or drilled without subsequent application of approved cut-end treatment.



REGISTER FOR YOUR  
**ANTI-ROT**  
GUARANTEE TODAY

PLEASE SCAN HERE:

