

# 4FT PENT LEAN-TO GREENHOUSE

Please retain product label and instructions for future reference

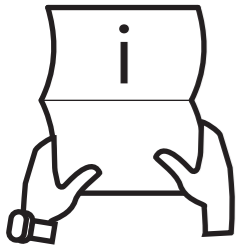

## BEFORE YOU START PLEASE READ THE INSTRUCTIONS CAREFULLY

- Check the pack and make sure you have all the items listed in the parts list provided.
- When you are ready to start, make sure you have the right tools at hand (not supplied - see the equipment list on next page).
- Ensure there is plenty of space and a clean dry area for assembly.
- Ensure you have enough time to fully assemble the main structure of your Greenhouse.

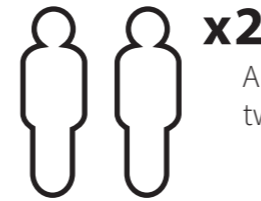

x2

All greenhouses should be erected by two adults

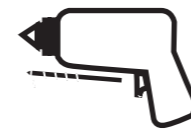

2mm Drill bit

For ease of assembly, you **MUST** pilot drill all screw holes and ensure all screw heads are countersunk.



For ease of assembly, you will need a tape measure to check dimensions of components and fixings.



Winter = High Moisture = Expansion  
Summer = Low Moisture = Contraction



## CAUTION

Every effort has been made during the manufacturing process to eliminate the prospect of splinters on rough surfaces of the timber. You are strongly advised to wear gloves when working with or handling rough sawn timber.

## \*\*Protim Aquatan T5 (621)\*\*

Your greenhouse has been dip treated with Aquatan.

Aquatan is a water-based concentrate which is diluted with water, the building has been treated by the correct application of Aquatan solution and then allowed to dry.

Aquatan is a decorative finish to colour the wood, which is applied industrially to timber fence panels and garden buildings.

Aquatan undiluted contains: boric acid, sodium hydroxide 32% solution, aqueous mixture of sodium dioctyl sulphosuccinat and alcohols: 2, 4, 6-trichlorophenol.

REGISTER FOR YOUR  
**10 YEAR**  
**ANTI-ROT**  
GUARANTEE TODAY

In all instances for assistance with your product or to register your anti rot guarantee, please contact us via our customer portal



[www.mgplogistics.co.uk](http://www.mgplogistics.co.uk)

Mercia Garden Products Limited, Sutton On Trent, Newark, Nottinghamshire, NG23 6QN

Screws & Nails

Measure overall length

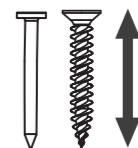

Bolts

Measure under the head



## LOCATION FOR YOUR GREENHOUSE

Ensure you have a suitable space available and cleared before beginning assembly:

- A minimum of 600mm should be left around the perimeter of your Greenhouse to allow access for maintenance, annual treatment and to allow air flow around the building.
- To fit your glazing, you require a minimum of 1500mm clearance on one side of your Greenhouse. This must be the side where the lowest end of the sloping roof will be positioned.
- Where possible, avoid placing your Greenhouse underneath large trees to prevent the tree causing damage to the building.

## BUILDING A BASE

When thinking about where the greenhouse and where the base is going to be constructed: Ensure that there will be access to all sides for maintenance work and annual treatment.

Ensure the base is level and is built on firm ground, to prevent movement. Refer to Page 5 for the base dimensions. The base should be slightly smaller than the external measurement of the greenhouse, i.e. The cladding should overlap the base, creating a run off for water. It is also recommended that the floor be at least 25mm above the surrounding ground level to avoid flooding.

## TYPES OF BASE

- Concrete 75mm laid on top of 75mm hard-core.
- Slabs laid on 50mm of sharp sand.
- Wooden base - Levelled / on posts / ground screws.

## TREATMENT

Once your Greenhouse has been installed it will need to be treated within 14 days (weather permitting) and then annually to prevent the timber from deteriorating and to waterproof it. This is required to maintain the anti-rot guarantee.

Dip Treated greenhouses - Require a preservative treatment to protect against rot and decay and a waterproof treatment to prevent water ingress.

## TIMBER

As with all natural materials, timber can be affected during various weather conditions. For the duration of heavy or extended periods of rain, swelling of the wood panels may occur. Warping of the wood may also occur during excessive dry spells due to an interior moisture loss. Unfortunately, these processes cannot be avoided but can be helped. It is suggested that the greenhouse is sprayed with water during extended periods of warm sunshine and sheltered as much as possible during rain or snow.

Whilst all products manufactured are made to the highest standards of safety and in the case of children's products independently tested to EN71 level, we cannot accept responsibility for your safety whilst erecting or using this product.



## TO DO LIST

- Find a suitable location to build (*see front cover for further information*).
- Build a base (*see front cover for further information*).
- Check the base is flat, level, clear of debris and has the required clearance on all sides (see page 1).
- Check you have the required equipment / tools.
- Check you have all the product items listed (*if you have missing or damaged parts please scan the QR code below to visit our online customer portal*).
- Install the product as per the step by step instructions within this pack.
- Prepare the product ready for treatment (this may include sanding).
- Apply a preserving and a waterproofing treatment within 14 days (*Weather permitting*) of installation (*pressure treated products do not require a preserver*).
- Register for your anti rot guarantee (*scan the QR below*).
- Tidy the build area and dispose of any remaining parts responsibly.
- Maintain your greenhouse (*see the manufacturers recommendations at the back of this pack*).

## EQUIPMENT LIST

- Hammer
- Flat Head Screwdriver
- Drill
- Drill Bit Set
- Phillips and Slotted Bit Sets
- Tape Measure
- Hand Saw
- Spirit Level
- Ladders/Steps
- Stanley Knife/Cutting Tool
- Sand Paper
- Gloves
- Silicone (For Windows Only)
- Sealant Application Gun
- Wood Filler (Optional)
- Timber Preservative Treatment (*not pressure treated products*)
- Timber Water Proofing Treatment
- Treatment Mixing Stick
- Paint Brush/Sprayer/Roller

## NEED EXTRA SUPPORT

If you are unsure that your base preparation will be suitable, please contact us via our customer portal to discuss this further.

Alternatively, you can visit our website or MGP Logistics Online Portal for some further shededucation.

### Website:

<https://www.merciagardenproducts.co.uk/sheducation>

### MGP Logistics Online Portal:

<https://www.mgplogistics.co.uk/>

Here you will find plenty of useful information that'll help with most pre-installation and maintenance queries.



### ANY QUESTIONS?

Scan the QR code to contact us via our customer portal.

## NOTES

## ACCESSING VIDEO GUIDES...

Some steps within this set of instructions come with an added video guide for your convenience. These can be accessed via the QR code and used to aid you in constructing that step. See below for how to use.

You can also find all the videos on our youtube channel:  
<https://www.youtube.com/@merciagardenproducts8716/videos>

### 1. Find the QR code within the instruction step...

#### Step.....

Parts Needed- No. QTY 1  
No. QTY 1  
No. QTY 1

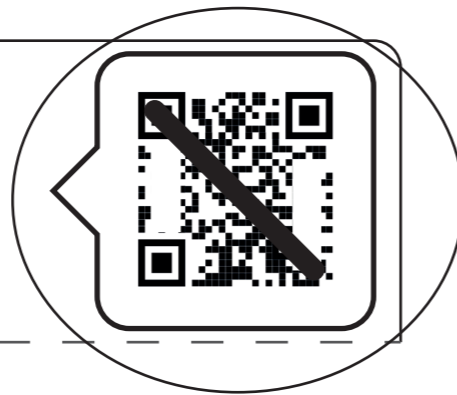

Within the instruction step, there will be an icon in the top right that has a QR code in. This is where the video can be accessed from.

*Please note: not every step has a video guide.*

### 2. Open camera app...

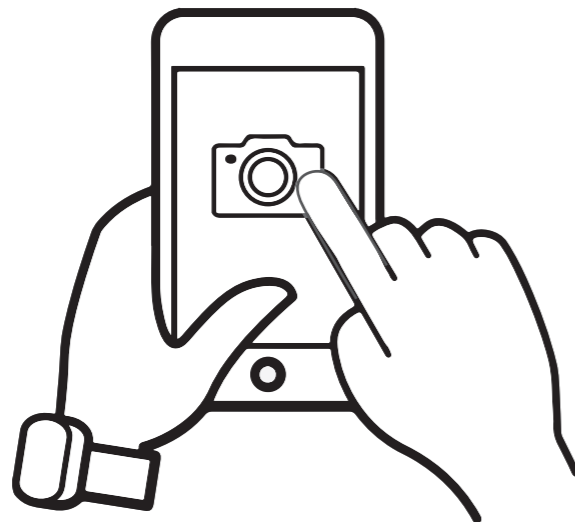

On your personal smart device (phone, tablet etc), open your camera app or QR code scanner app.

## ACCESSING VIDEO GUIDES...

### 3. Scan QR code...



To scan the QR code, hold the camera over the QR code so that it can be seen on the screen. Once the QR code has been registered, follow the prompts on your device to open the video. (This will vary depending on your device.)

*Please note: Ensure to use the back camera of your smart device as this will scan the QR code more accurately.*

### 4. Watch the video...



The video guide will now be displayed on your smart device.

**Disclaimer:** The garden building constructed in the video guides may be constructed differently to your building. Please ensure to read your instructions carefully to avoid error.

## What is a Modular Greenhouse?

A Modular Greenhouse allows you to choose the layout of your Greenhouse, yourself.

The 2ft Door and Glazed Panels (No. 1a & 1b) are interchangeable with each other, and can be swapped and positioned however you choose.

*Please note: The buildings shown may differ in size from your chosen building however the process of interchanging the Panels is the same.*

## How should I position my panels?

This instruction manual contains steps to construct one building with different options ;

- 8x4 Lean-To Greenhouse.
- 8x4 Lean-To Greenhouse with height extension

These buildings can be constructed with the panels in different configurations, as explained above. Ensure you have decided how you would like your building to look before beginning construction.

***We recommend positioning your Door on one end, as this allows for the most usable space inside your Greenhouse. However, the Door can be placed in any position.***

## What building do I have?

All of our modular Greenhouses have different names and different components, so it's important to understand what building you have and what comes with it before beginning assembly. Please refer to the information below to check what type of building you have before beginning construction.

### 4ft Lean-To Greenhouse.

The building you have purchased is referred to generically as a '4ft Lean-To Greenhouse' and this instruction manual contains steps to construct one size building;

- 8x4 Lean-to Greenhouse.

*For your exact building reference codes and a full building breakdown, please see the pages to follow that contain your chosen building size. For base options, please see the 4ft Base assembly instructions guide.*

### What does the building name mean?

The building you have purchased will be named as shown above, for example: **8x4 Lean-To Greenhouse.**

### 8x4 Lean-To Greenhouse:

8 - the depth of the building. This building is 8ft deep.

4 - the width of the building. This building is 4ft wide.

Pent Lean-To - the roof type. This building is a Pent Lean-To, which means the roof consists of a single sloped surface and has one open side to be leant against a wall or structure.

Greenhouse - the building structure. This building is a Greenhouse, which means the majority of wall and roof panels are glazed.

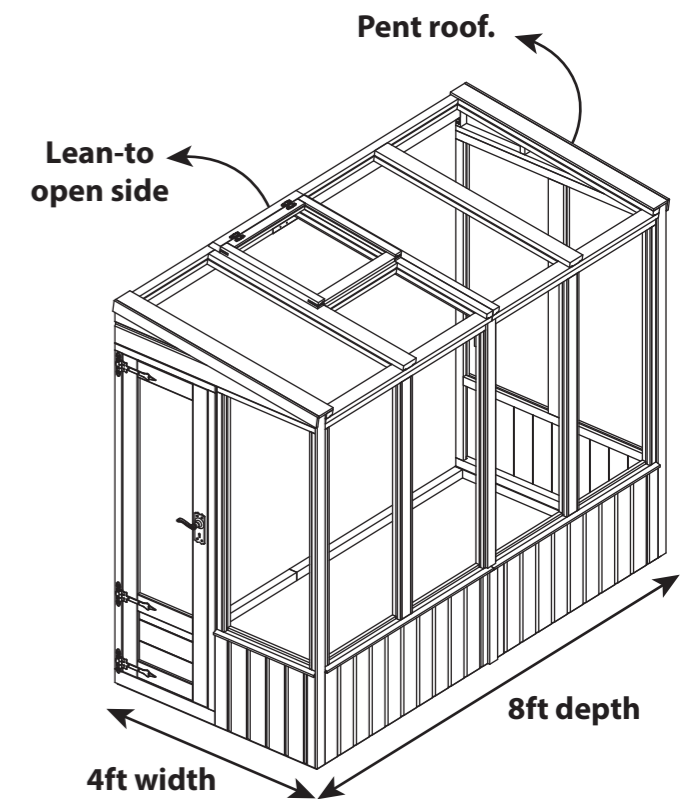

***All of the Greenhouses in this manual are 4ft wide, with differing depths. Throughout the instructions, ensure to check that you are referring to the correct building where necessary.***



### ANY QUESTIONS?

Scan the QR code to contact us via our customer portal.

# 8x4

### Standard base

**Overall Dimensions:**  
 Width = 1205mm  
 Depth = 2496mm  
 Height = 2061mm

**Base Dimensions:**  
 Width = 1180mm  
 Depth = 2448mm

### Standard base + Height Extension

**Overall Dimensions:**  
 Width = 1205mm  
 Depth = 2496mm  
 Height = 2172mm

**Base Dimensions:**  
 Width = 1180mm  
 Depth = 2448mm

### Premium base

**Overall Dimensions:**  
 Width = 1205mm  
 Depth = 2496mm  
 Height = 2075mm

**Base Dimensions:**  
 Width = 1180mm  
 Depth = 2420mm

### Premium base + Height Extension

**Overall Dimensions:**  
 Width = 1205mm  
 Depth = 2496mm  
 Height = 2185mm

**Base Dimensions:**  
 Width = 1180mm  
 Depth = 2420mm

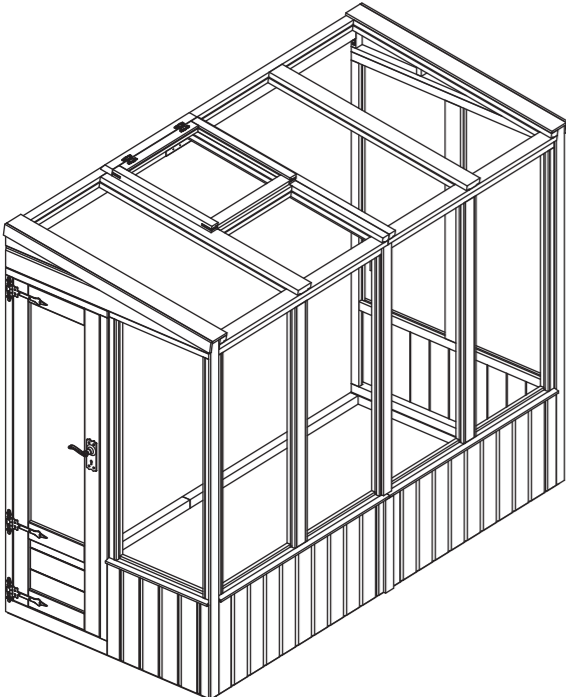

Standard

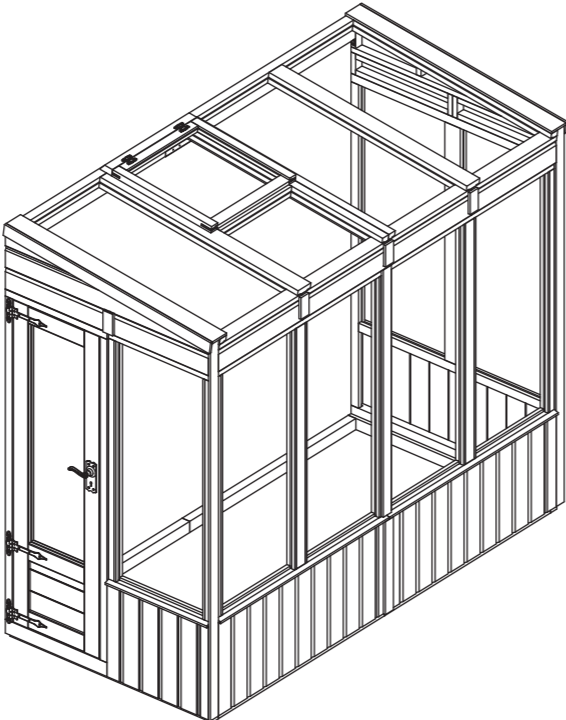

Height Extension

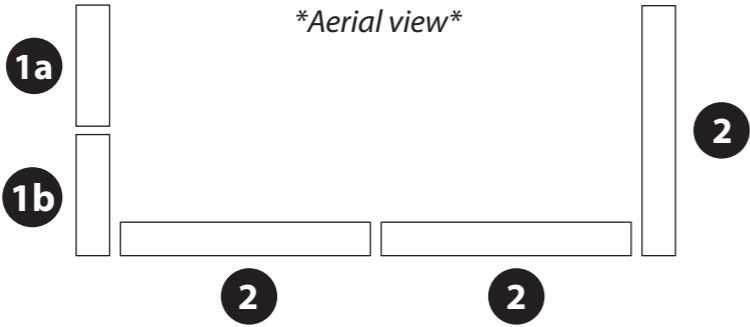

**Building Breakdown**

**Main Buildings:**

- SI-100-004-0025 - 8x4 Pent Lean-To Greenhouse with Styrene
- SI-100-004-0026 - 8x4 Pent Lean-To Greenhouse with Polycarbonate
- SI-100-004-0027 - 8x4 Pent Lean-To Greenhouse with Glass

**Upgrades:**

- SI-100-004-0028 - 8x4 Pent Lean-To Additional Height

**Building Contents:**

In the tables to follow, please refer to the row with your chosen building size in to determine how many of each part is required.

We highly recommend checking you have all the required components before beginning assembly.

Tip: Labelling your parts, using a pencil and masking tape, may help you to identify them easier when you need them.

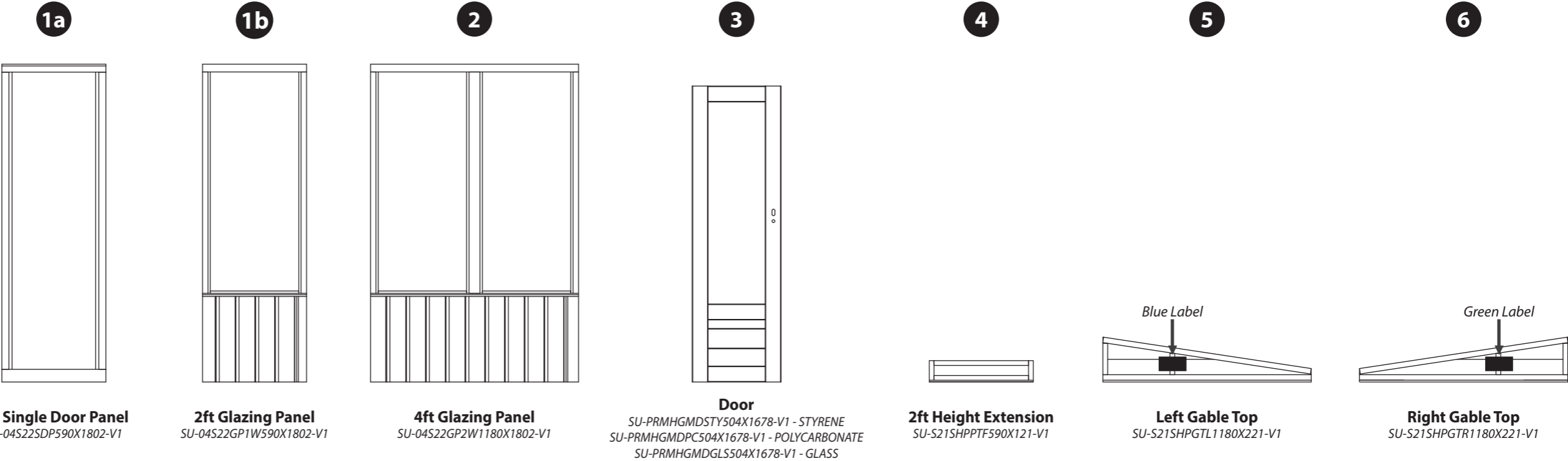
**2ft Single Door Panel**  
SU-04S22SDP590X1802-V1

**2ft Glazing Panel**  
SU-04S22GP1W590X1802-V1

**4ft Glazing Panel**  
SU-04S22GP2W1180X1802-V1

**Door**  
SU-PRMHGMDSTY504X1678-V1 - STYRENE  
SU-PRMHGMDPC504X1678-V1 - POLYCARBONATE  
SU-PRMHGMDGLS504X1678-V1 - GLASS

**2ft Height Extension**  
SU-S21SHPTTF590X121-V1







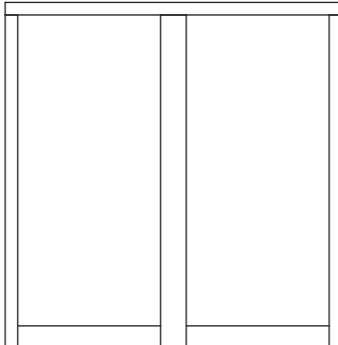
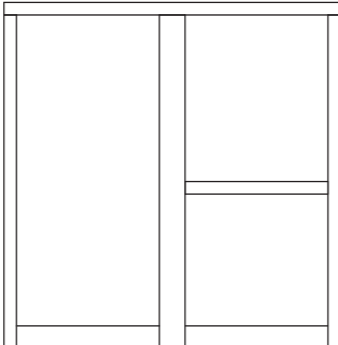
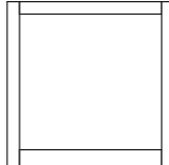

**Left Gable Top**  
SU-S21SHPGTL1180X221-V1

**Right Gable Top**  
SU-S21SHPGTR1180X221-V1

<b>8 X 4 LEAN-TO GREENHOUSE</b>	<b>QTY 1</b>	<b>QTY 1</b>	<b>QTY 3</b>	<b>QTY 1</b>	<b>QTY 8</b>	<b>QTY 1</b>	<b>QTY 1</b>
---------------------------------	--------------	--------------	--------------	--------------	--------------	--------------	--------------

*Included with 'Additional Height upgrade' only.*

**Building Contents:**

	<b>7</b>	<b>8</b>	<b>9</b>	<b>10</b>	<b>11</b>	<b>12</b>	<b>13</b>	<b>14</b>	<b>15</b>	<b>16</b>
										
	<b>4ft Roof</b> <i>SU-04S32GR2W1180X1204-V1</i>	<b>4ft Opening Window Roof</b> <i>SU-04S32GROW3W1180X1204-V1</i>	<b>Window</b> <i>SU-SW590X580-V1</i>	<b>4ft Ridge Bar</b> <b>27x70x1180mm</b> <i>F2770-1180mm-DT</i>	<b>Window Block</b> <b>65x35x590mm</b> <i>F6535-G-590mm</i>	<b>Truss Frame</b> <b>27x44x1122mm</b> <i>F2744-G-1162mm</i>	<b>Truss block</b> <b>27x44x140mm</b> <i>F2744-G-160mm</i>	<b>Cover Trim**</b> <b>12x56x2100mm</b> <i>S1256-2100mm</i>	<b>Roof Trim**</b> <b>12x100x2100mm</b> <i>S12100-2100mm-DT</i>	<b>Fascia**</b> <b>12x60x2000mm</b> <i>S1260-2000mm-DT</i>

<b>8 X 4 LEAN-TO GREENHOUSE</b>	<b>QTY 1</b>	<b>QTY 1</b>	<b>QTY 1</b>	<b>QTY 2</b>	<b>QTY 1</b>	<b>QTY 1</b>	<b>QTY 2*</b>	<b>QTY 6*</b>	<b>QTY 2</b>	<b>QTY 2</b>
---------------------------------	--------------	--------------	--------------	--------------	--------------	--------------	---------------	---------------	--------------	--------------

\*You may have more of this part that required.

\*\*This part will be longer than needed and requires cutting to size when used. This will be explained when required within the instruction step.  
 Note: one piece may be required to be cut into multiple different sizes. Do not dispose of off-cuts until the building is fully constructed as they may be needed in another step.

**Building Contents:**

- 17
- 18
- 19
- 20
- 21
- 22
- 23
- 24

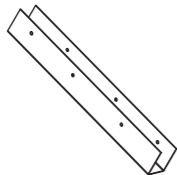

**U-Channel**  
PI-07-0013

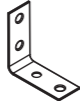

**Corner Brace**  
PI-07-0012

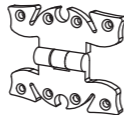

**Butt-Hinge**  
PI-07-0004

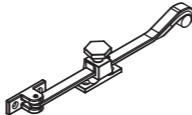

**Casement Stay**  
PI-07-0080

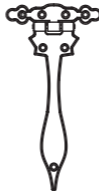

**T-Hinge**  
PI-07-0002



**Lock**  
PI-07-0017



**Key-Plate**  
PI-07-0017

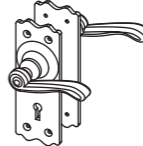

**Handle Set**  
PI-07-0006

**8 X 4 LEAN-TO GREENHOUSE**

**QTY 1**

**QTY 4**

**QTY 2**

**QTY 1**

**QTY 3**

**QTY 1**

**QTY 1**

**QTY 1**

*\*You may have more of this part that required.*

**\*\*This part will be longer than needed and requires cutting to size when used. This will be explained when required within the instruction step.  
Note: one piece may be required to be cut into multiple different sizes. Do not dispose of off-cuts until the building is fully constructed as they may be needed in another step.**



## Screw Packs

In the table below, please refer to the row with your chosen building size and type in to determine how many of each screw is required.

There may be extra screws in the pack.

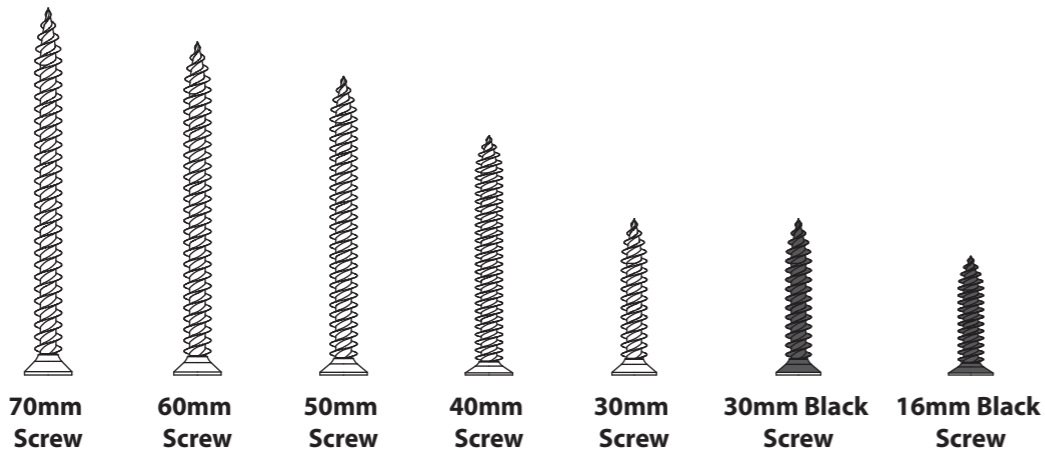

<b>8 X 4 LEAN-TO GREENHOUSE</b>	<b>QTY 23</b>	<b>QTY 20</b>	<b>QTY 48</b>	<b>QTY 8</b>	<b>QTY 62</b>	<b>QTY 51</b>	<b>QTY 4</b>
---------------------------------	---------------	---------------	---------------	--------------	---------------	---------------	--------------

We do not include wall fixings with this product due to wall construction materials varying from property to property. If you are unsure on the fixings you require, we recommend that you consult with your local builders merchant or knowledgeable DIY store.

**Before assembly, please make sure you have followed instructions to assemble your Greenhouse Base frame.**

**If not, please refer to the '4ft Base frame construction' manual provided with your building.  
*This must be constructed before assembling your Greenhouse.***

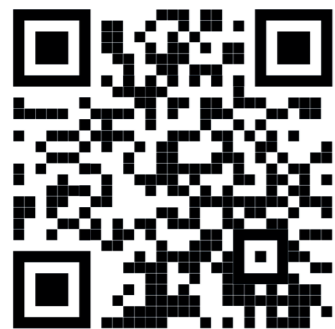

### Missing parts?

Scan the QR code to visit our customer portal where you can quickly raise any missing or damaged parts and get a replacement sent out ASAP.



## Step 1

### Parts Needed

<b>Building</b>	<b>No. 1a</b>	<b>No. 3</b>	<b>No. 21</b>	<b>30mm black screw</b>
<b>All sizes</b>	<b>QTY 1</b>	<b>QTY 1</b>	<b>QTY 3</b>	<b>QTY 27</b>

**IMPORTANT: Pre-drill before fixing screws.**

- a** Lay the 2ft Single Door Panel (**No. 1a**) face up on a flat and level surface.

To ensure the panel is the correct way up, check that the internal lips on either side of the upright framing are visible.

- b** Place the Door (**No. 3**) within the Door Panel opening so it is sat on the internal lipped edges.

Ensure there is equal spacing on all sides and that the cut outs on the Door are lined up with the cut out in the door frame.

Locate the T-Hinges (**No. 21**) onto the Door and Door Panel, ensuring the Hinges line up with the Door framing.

Secure in place using 9x30mm black screws per hinge.

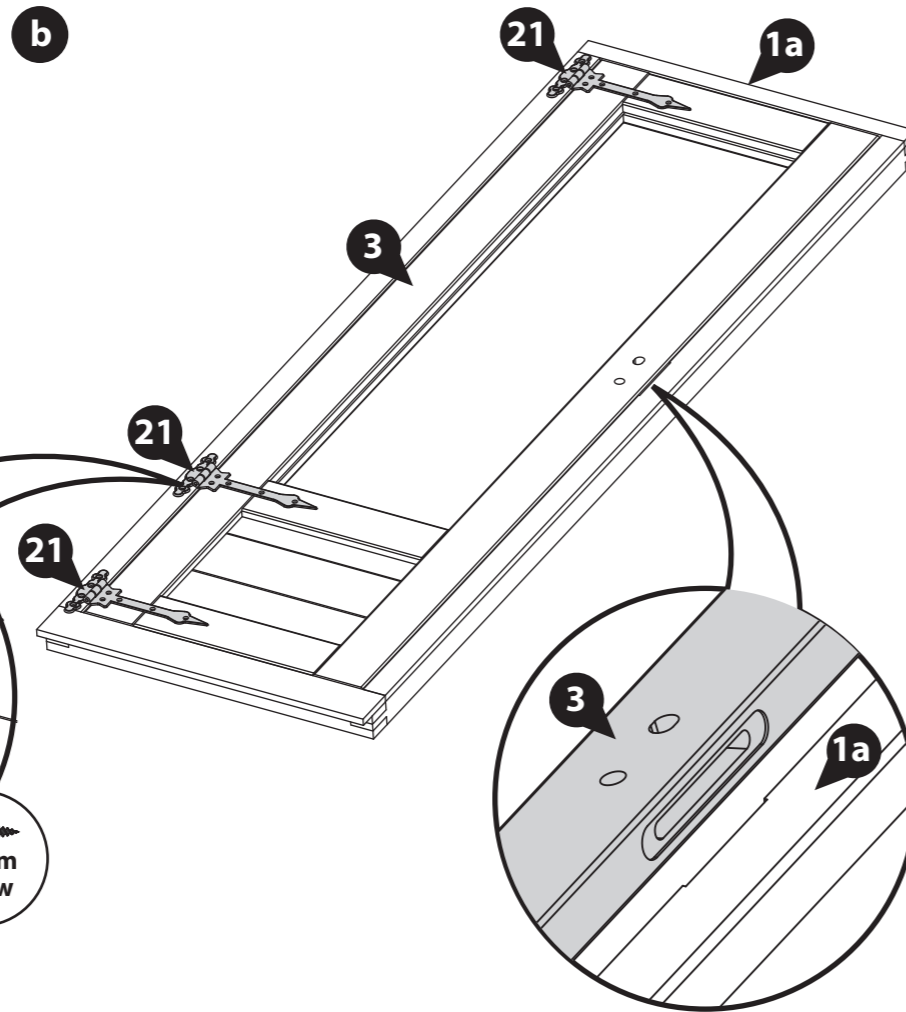
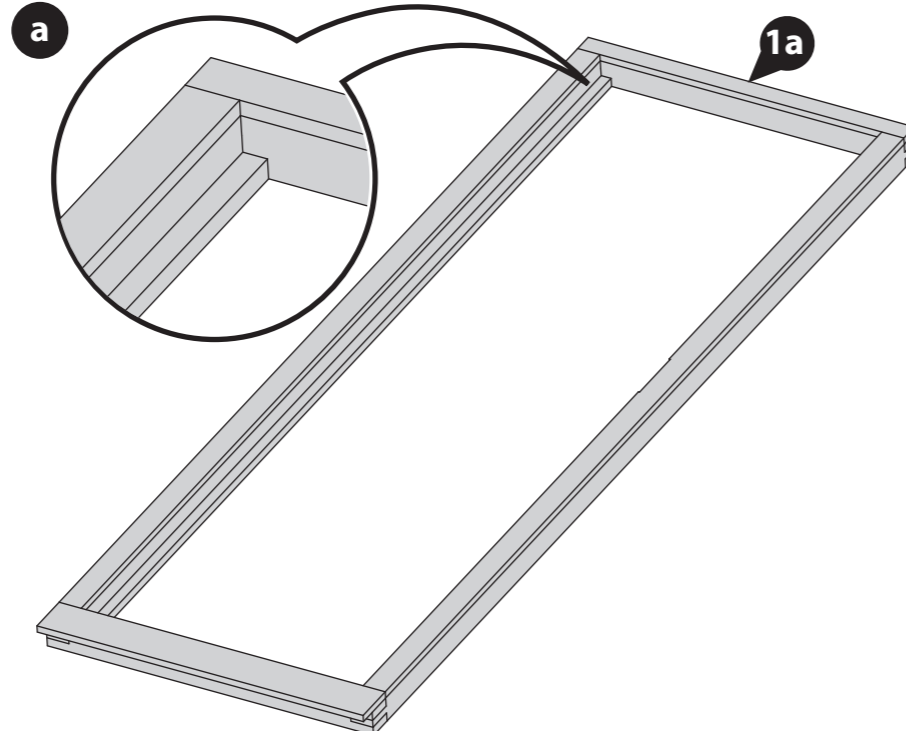

## Step 2

### Parts Needed

<b>Building</b>	<b>No. 22</b>	<b>No. 23</b>	<b>30mm screw</b>
<b>All sizes</b>	<b>QTY 1</b>	<b>QTY 1</b>	<b>QTY 4</b>

**IMPORTANT: Pre-drill before fixing screws.**

Open the Door and locate the Lock (**No. 22**) into the recess of the Door (**No. 3**). Fix in place using 2x30mm screws.

Locate the Key-Plate (**No. 23**) onto the recess on the inside of the Door Panel (**No. 1a**). Fix in place using 2x30mm screws.

**Do NOT shut the door fully until the Handle Set has been fitted in step 3.**

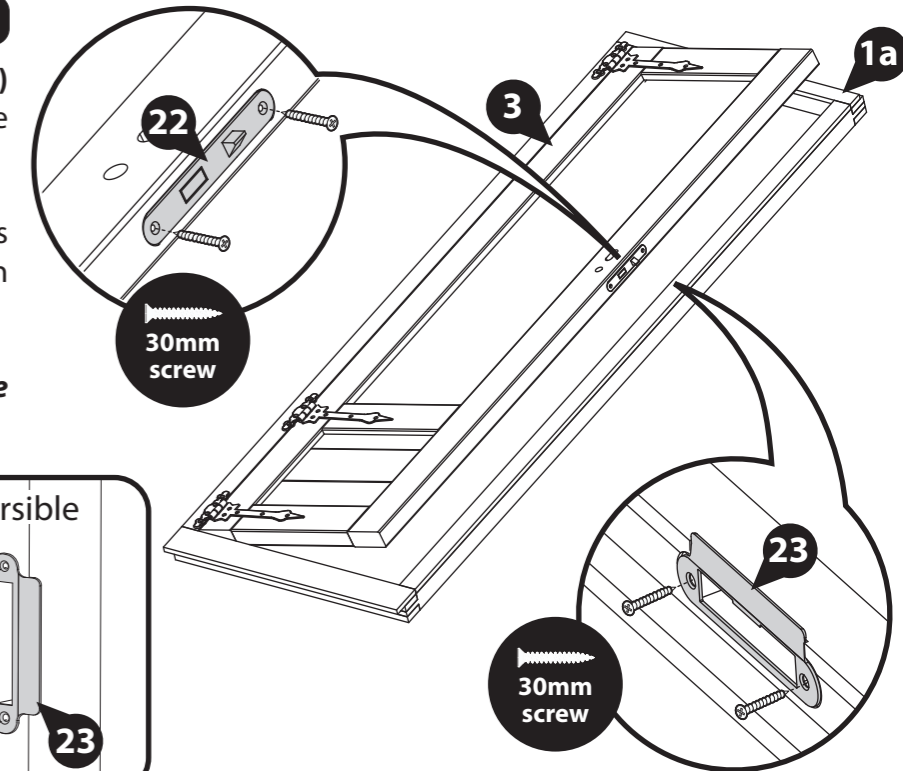
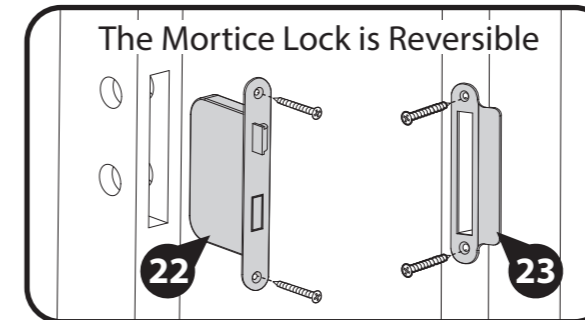

## Step 3

### Parts Needed

<b>Building</b>	<b>No. 24</b>	<b>30mm black screw</b>
<b>All sizes</b>	<b>QTY 1</b>	<b>QTY 8</b>

**IMPORTANT: Pre-drill before fixing screws.**

From the Handle Set (**No. 24**) position the Metal Bar through the Door and lock and connect one handle onto either side, as shown.

Fix each Handle in place using 4x30mm black screws.

Before closing the door, ensure the door mechanism works by checking that the lock (**No. 22**) moves with the Handle set.

Then, check the door can open and close freely.

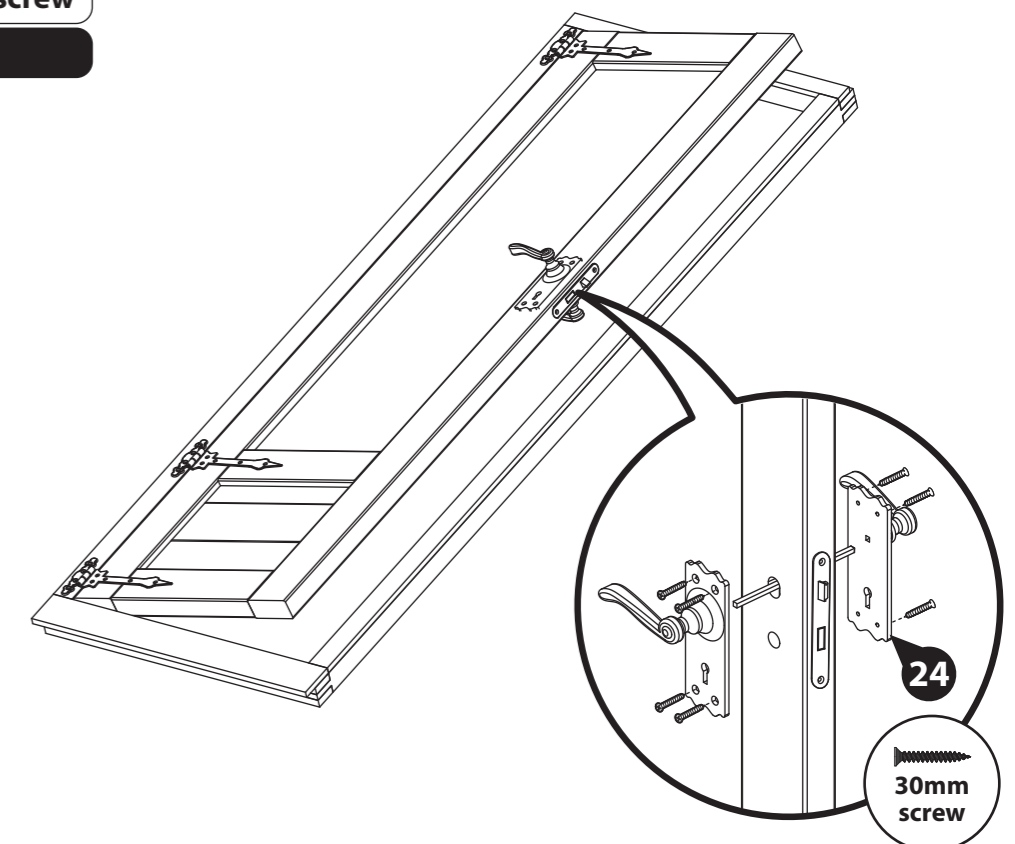

## Step 4

- a** Before assembling the Greenhouse walls, ensure you have constructed your Greenhouse Base framing and that it is square and level.

*If not, please refer to the '4ft Base frame' manual provided with your building.*

- b** With your base constructed, decide how you want your panels to sit.

**We recommend positioning your Door on one end, as this allows for the most usable space inside your Greenhouse. However, the Door can be placed in any position.**

It is advised to lay your panels around the base frame in the desired positions, an example is shown below.

*Please note: the 8x4 has been shown for illustrative purposes and may differ from your chosen building. However the process of laying out the Panels is the same.*

**a**

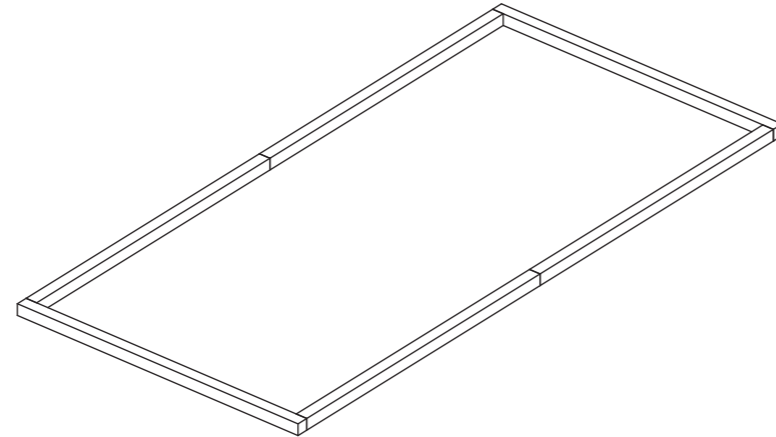

**b**

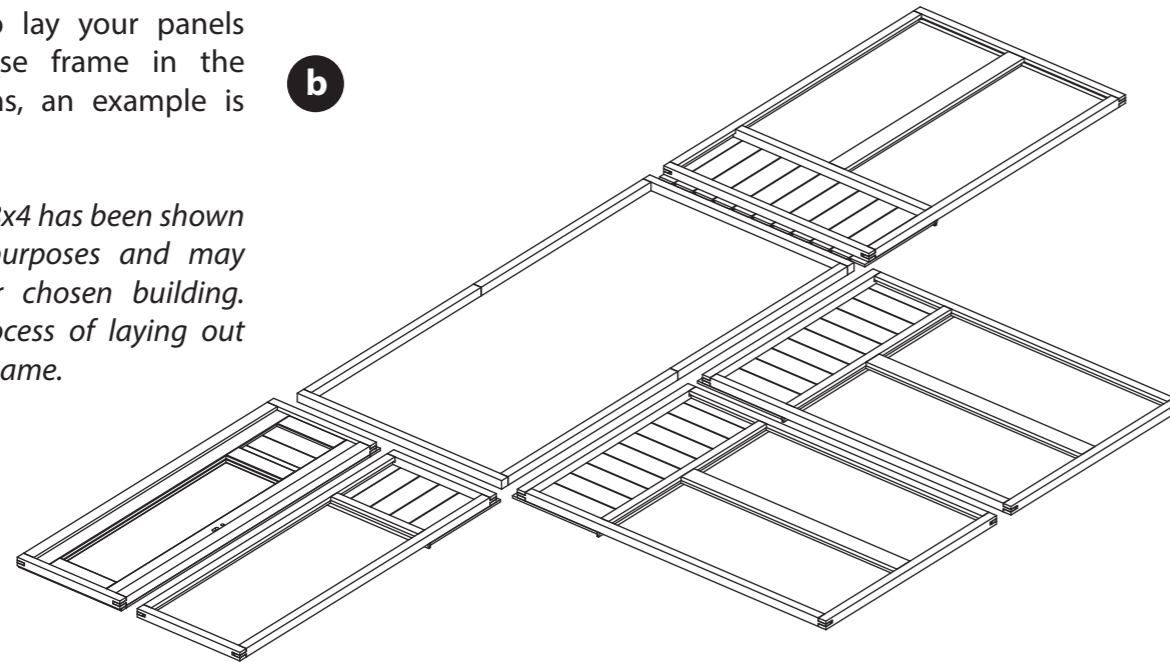

## Step 5

### Parts Needed

Building	No. 2	60mm screw
8x4	QTY 2	QTY 3

**\*\*Please note: the 2ft panels (No. 1a & 1b) are interchangeable and can be positioned in a variety of different configurations. Decide which works best for you before assembly.**

Locate one 4ft Glazing Panel (No. 2) on top of the base frame at one end. On the inside of the end panel, create the corner by positioning another 4ft Glazing Panel (No. 2).

Secure the Panels together at the corner using 3x60mm screws, as shown.

Ensure to position the Panels so the 4ft Panel on the end is flush to the base frame on the open side, as shown. Make sure to position the Panels so there is equal spacing between the overhanging cladding and the base frame on all sides.

**Do NOT secure the building to the base frame until the roof has been fitted.**



**a**

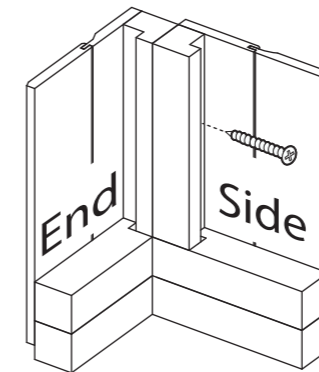

**60mm screw**

**IMPORTANT: Pre-drill before fixing screws.**

8x4

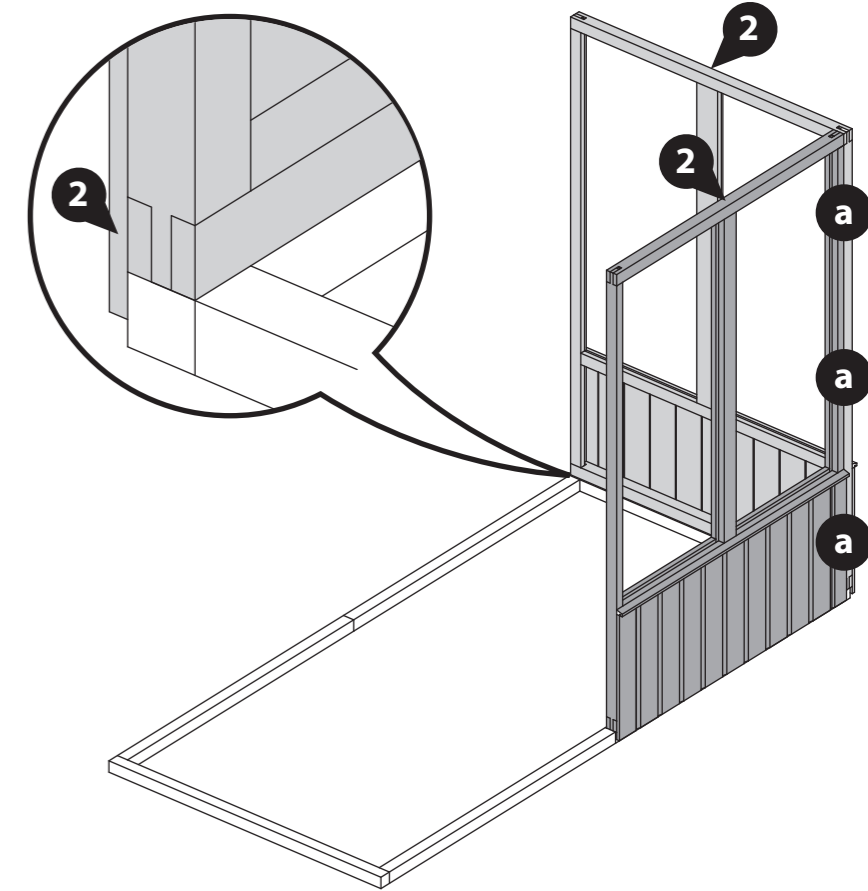

## Step 6

### Parts Needed

<b>Building</b>	<b>No. 2</b>	<b>60mm screw</b>
<b>8x4</b>	<b>QTY 1</b>	<b>QTY 3</b>

Locate another 4ft Glazing Panel (**No. 2**) next to the previously placed Panel on the side, as shown.

Secure the Panels together using 3x60mm screws, as shown.

Make sure to position the Panels so there is equal spacing between the overhanging cladding and the base frame on all sides.

**Do NOT secure the building to the base frame until the roof has been fitted.**



**b**

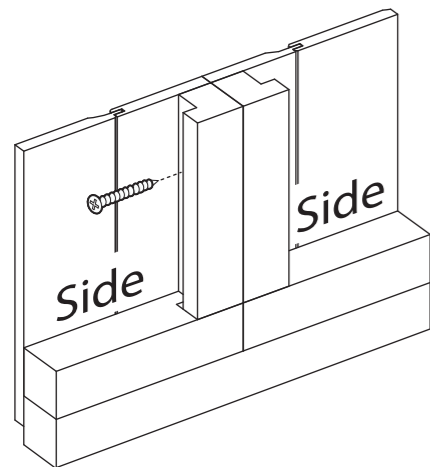

**IMPORTANT: Pre-drill before fixing screws.**

8x4

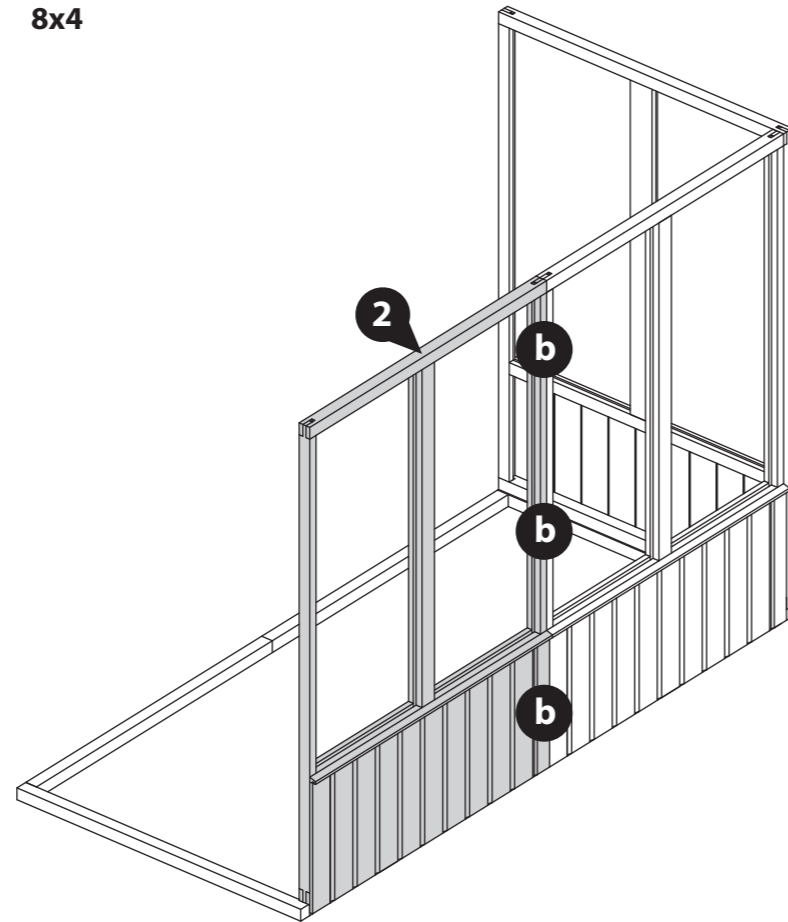

## Step 7

### Parts Needed

<b>Building</b>	<b>No. 1 (a or b)</b>	<b>60mm screw</b>
<b>All sizes</b>	<b>QTY 2</b>	<b>QTY 6</b>

Locate the 2ft Panels (**No. 1a & 1b**) on top of the floor at the end, ensuring they sit on the outside of the previously placed panel, as shown.

Fix the Panels together using 3x60mm screws per join, as shown.

Secure the Panels together at the corner using 3x60mm screws per corner.

Ensure to position the Panels so the Panel on the end is flush to the base frame on the open side, as shown. Make sure to position the Panels so there is equal spacing between the overhanging cladding and the base frame on all sides.

**Do NOT secure the building to the base frame until the roof has been fitted.**



**a**

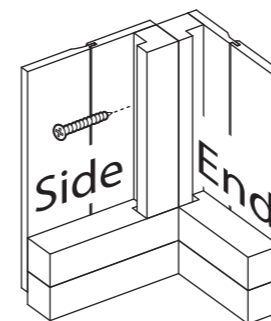

**b**

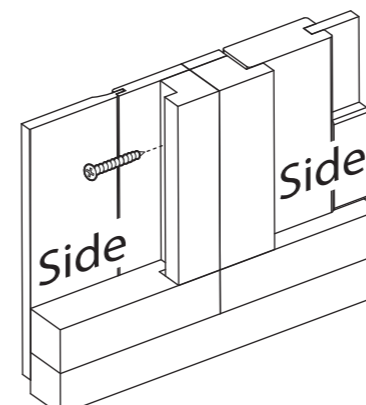

**IMPORTANT: Pre-drill before fixing screws.**

8x4

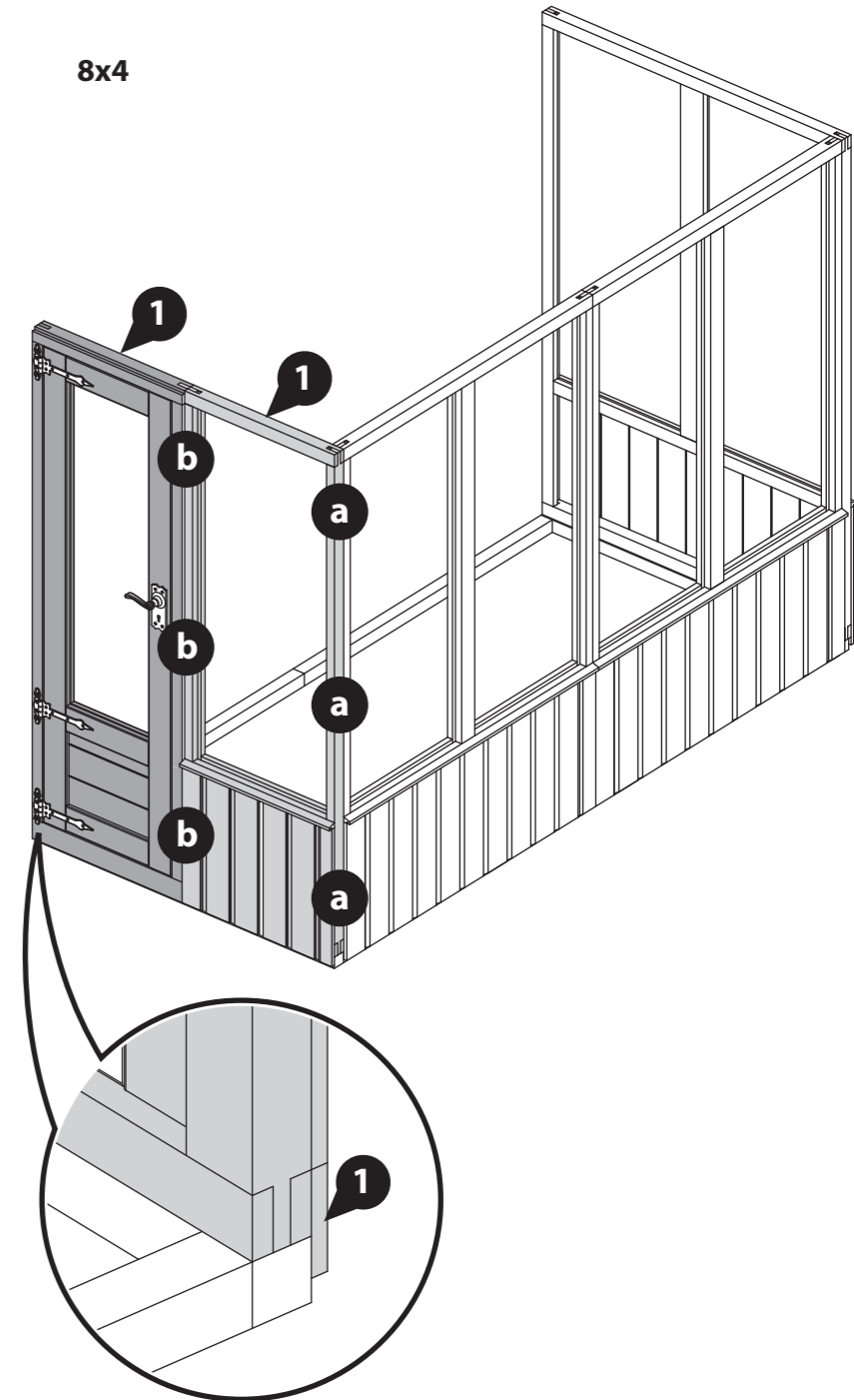

## Step 8

### Parts Needed

<b>Building</b>	<b>No. 4</b>	<b>50mm screw</b>
<b>8x4</b>	<b>QTY 8</b>	<b>QTY 31</b>

### Additional Height upgrade only.

If you have not purchased the Additional Height upgrade, then please skip to the next step (Step 9).

**a** At one end of the building, locate two 2ft Height Extension Panels (**No. 4**) on top of the end panels, as shown. Ensure each Extension Panel is flush and level with the wall Panel framing below and to the adjacent Extension Panel.

Secure each Panel in place using 3x50mm screws, screwing down through the Extension Panel framing into the wall panel framing below.

Fix the Extension panels together using 1x50mm screw, screwing through the upright framing into the panel framing behind.

**b** Continue to Position the 2ft Height Extension Panels (**No. 4**) around the top of the building. Ensure each is flush to the panel below and the adjacent Extension Panel.

Secure each to the panel below using 3x50mm screws per Panel. Fix together using 1x50mm screw. When fixing at a corner, ensure to screw through the upright framing into the panel behind, as shown.

Please note: the 8x4 has been shown for illustrative purposes and may differ from your chosen building. However the process of fitting the Height Extension Panels is the same.

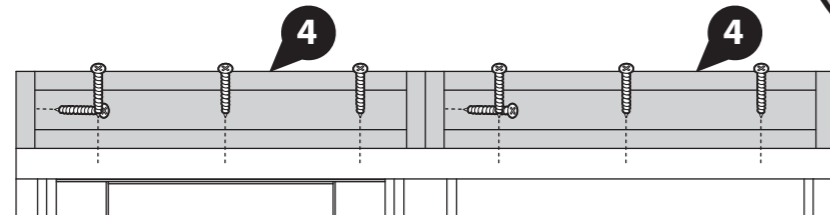

**IMPORTANT: Pre-drill before fixing screws.**

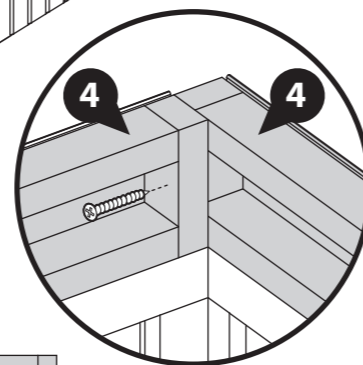
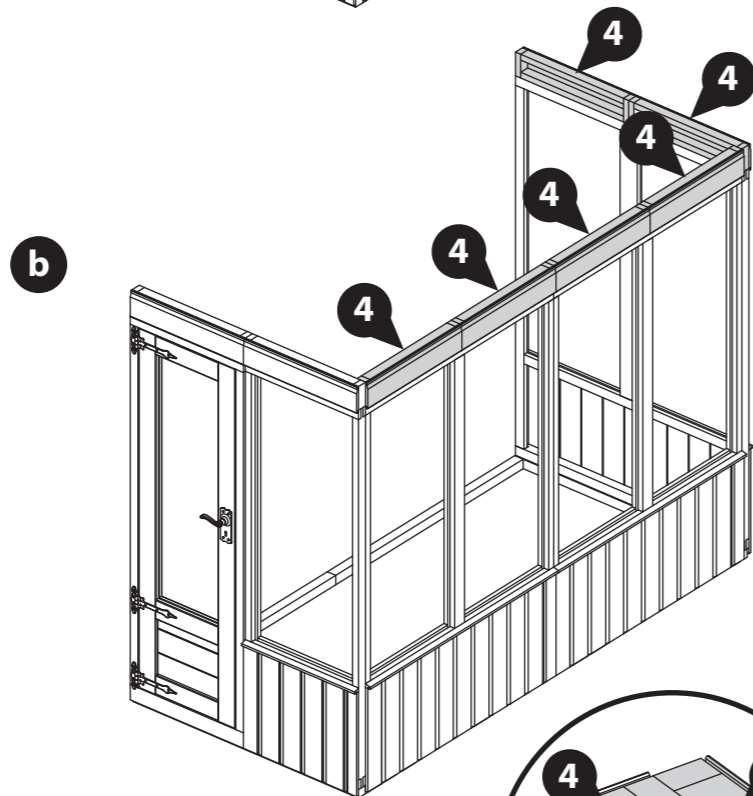
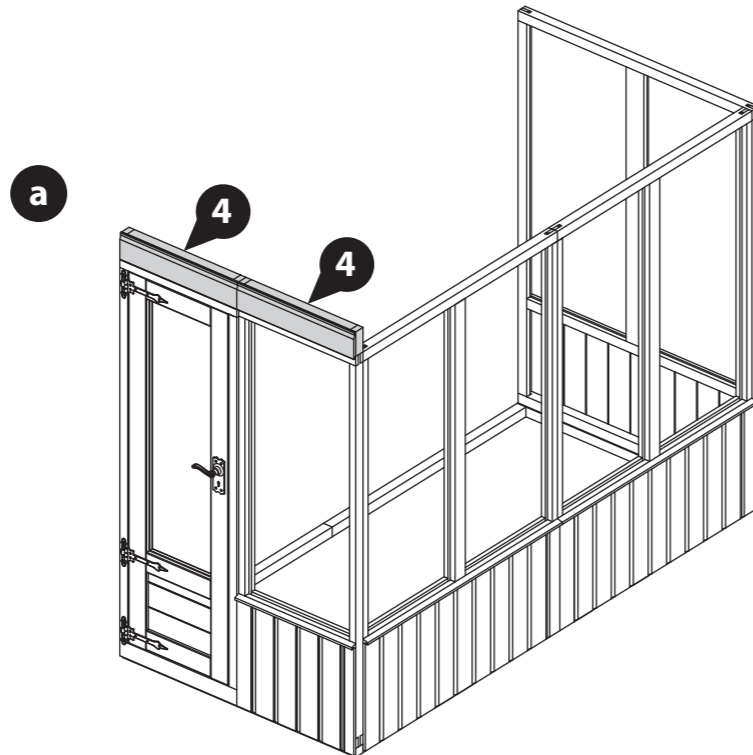

## Step 9

### Parts Needed

<b>Building</b>	<b>No. 5</b>	<b>No. 6</b>	<b>60mm screw</b>
<b>All sizes</b>	<b>QTY 1</b>	<b>QTY 1</b>	<b>QTY 8</b>

Locate the Gable Tops (**No. 5 & 6**) on top of the end Panels, ensuring that the framing is flush and level.

Make sure that the tallest part of the Gable Top is positioned towards the open side of the building, as shown.

Secure in place using 4x60mm screws per Gable, screwing down through the Gable framing into the Panel below.

### Height Extension only:

Ensure that the Gable cladding slots into the top cladding on the Height extension panel below, as shown.

Please note: the 8x4 has been shown for illustrative purposes and may differ from your chosen building. However the process of fitting the Gable Tops is the same.

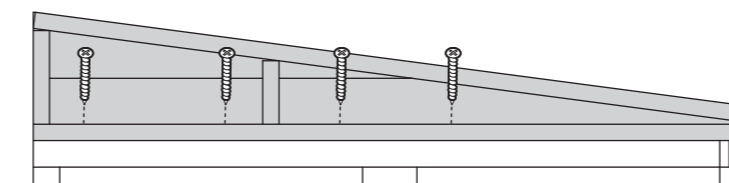

Standard

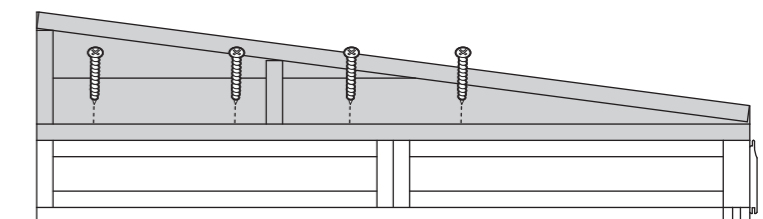

Height Extension

**IMPORTANT: Pre-drill before fixing screws.**

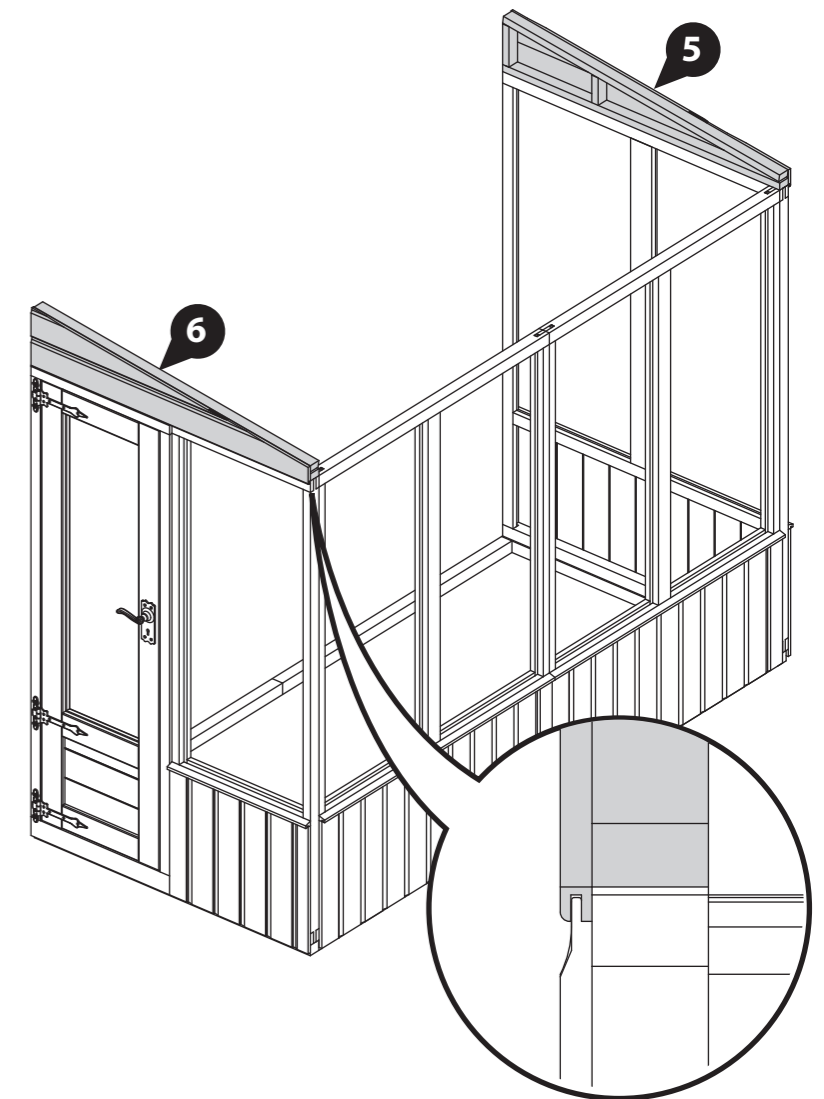

## Step 10

### Parts Needed

Building	No. 10	No. 17	No. 18	30mm screw
8x4	QTY 2	QTY 1	QTY 2	QTY 14

Position the Ridge Bars (**No. 10**) in a row so the ends are flush together and the faces are level. Position one U-channel (**No. 17**) centrally across each join and secure in place using 10x30mm screws.

Locate one Corner Brace (**No. 18**) onto either end of the Ridge Bars, ensuring they are flush with the ends of the framing, as shown.

Secure in place using 2x30mm screws per Corner Brace (**No. 18**).

This has constructed your Ridge bar.

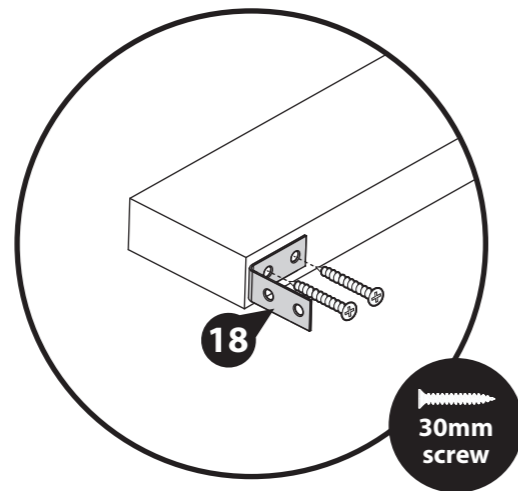
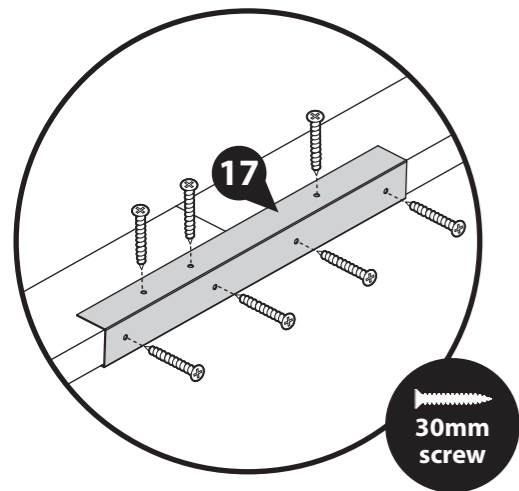

**IMPORTANT: Pre-drill before fixing screws.**

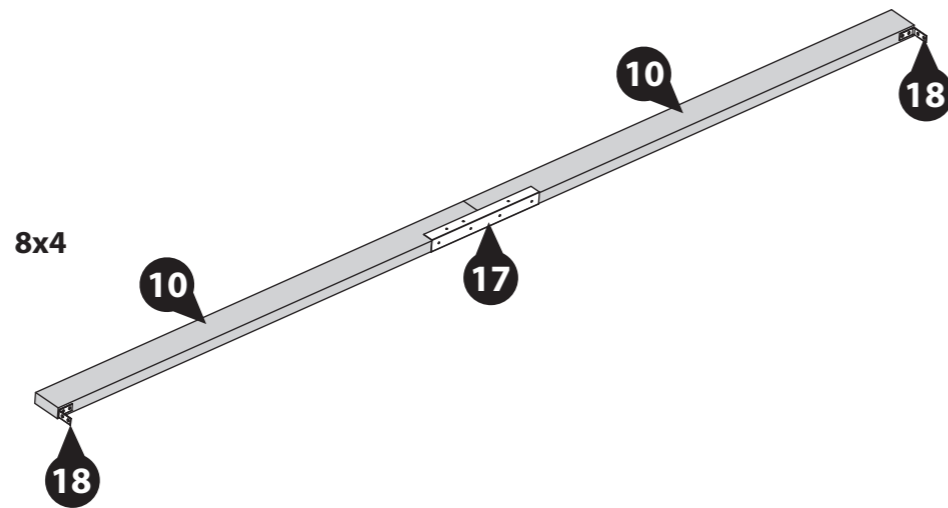

## Step 11

### Parts Needed

Building	30mm screw
All sizes	QTY 4

Align the assembled Ridge Bar (**No. 10**) with the outer-most framing of the Gable Tops, ensuring the sides are flush.

Position the Ridge Bar 62mm below the top point of the Gable Tops, as shown.

*(If you have not yet assembled your Ridge Bar, please refer to step 10).*

Secure the Corner Braces (**No. 18**) to the upright of the Gable Tops using 2x30mm screws per brace.

*Please note: the 8x4 has been shown for illustrative purposes and may differ from your chosen building. However the process of fitting the Ridge Bar is the same.*

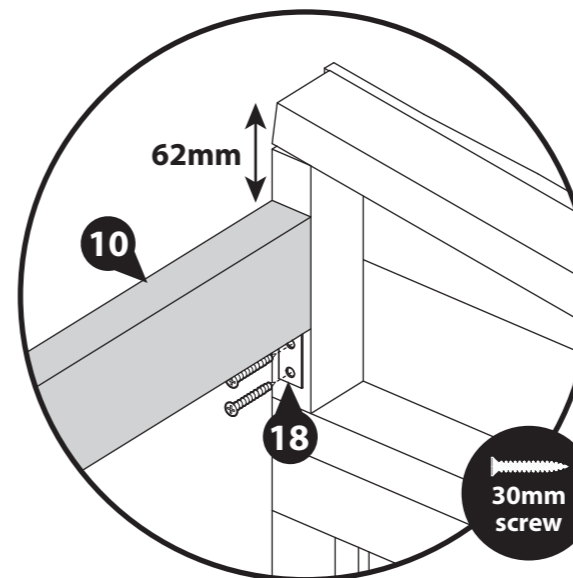

**IMPORTANT: Pre-drill before fixing screws.**

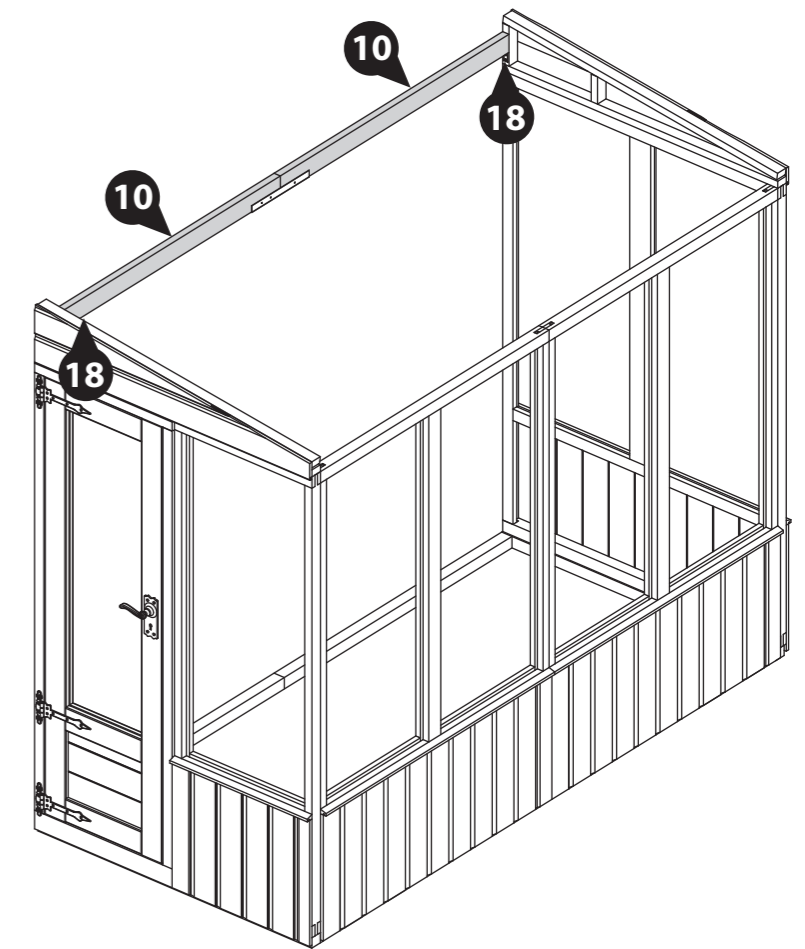

**IMPORTANT: Pre-drill before fixing screws.**

## Step 12

### Parts Needed

Building	No. 8	No. 9	No. 11	No. 14	No. 19	No. 20	16mm black screw	30mm black screw	30mm screw	50mm screw
8x4	QTY 1	QTY 1	QTY 1	QTY 1	QTY 2	QTY 1	QTY 4	QTY 16	QTY 2	QTY 2

- a** Place the 4ft Opening Window Roof (**No. 8**) face up on a flat and level surface.

Position the Window (**No. 9**) and the Window Block (**No. 11**) onto the Roof Panel (**No. 8**) framing, over the open space at the top right of the panel, as shown. The two should be flush and level with the side of the Roof Panel.

Ensuring the Window Block sits just below the top of the Panel and the Window sits on the central framing, secure the Window Block (**No. 11**) in place using 2x50mm screws.

- b** Place the Butt-Hinges (**No. 19**) onto the Window and Window Block. Fix in place using 8x30mm black screws per hinge.

- c** Whilst holding the window shut, flip the Panel over and position the Casement Stay (**No. 20**) centrally inside the Window, so the stay and pins align with the Roof and Window framing, as shown.

*\*\*Please ensure to support the window when flipping the panel as the window is not fully secured at this point and WILL open.*

Secure in place using 4x16mm black screws.

- d** With the Panel face down, measure the distance between the roof framing, as shown.

Mark this measurement onto one Cover Trim (**No. 14**) and cut to size.

Position the Cover Trim (**No. 14**) in between the top Roof framing, flush to the top framing. Ensure to cover the join between the Window and Window Block, as shown.

Secure in place using 2x30mm screws, screwing through the trim into the window block behind.

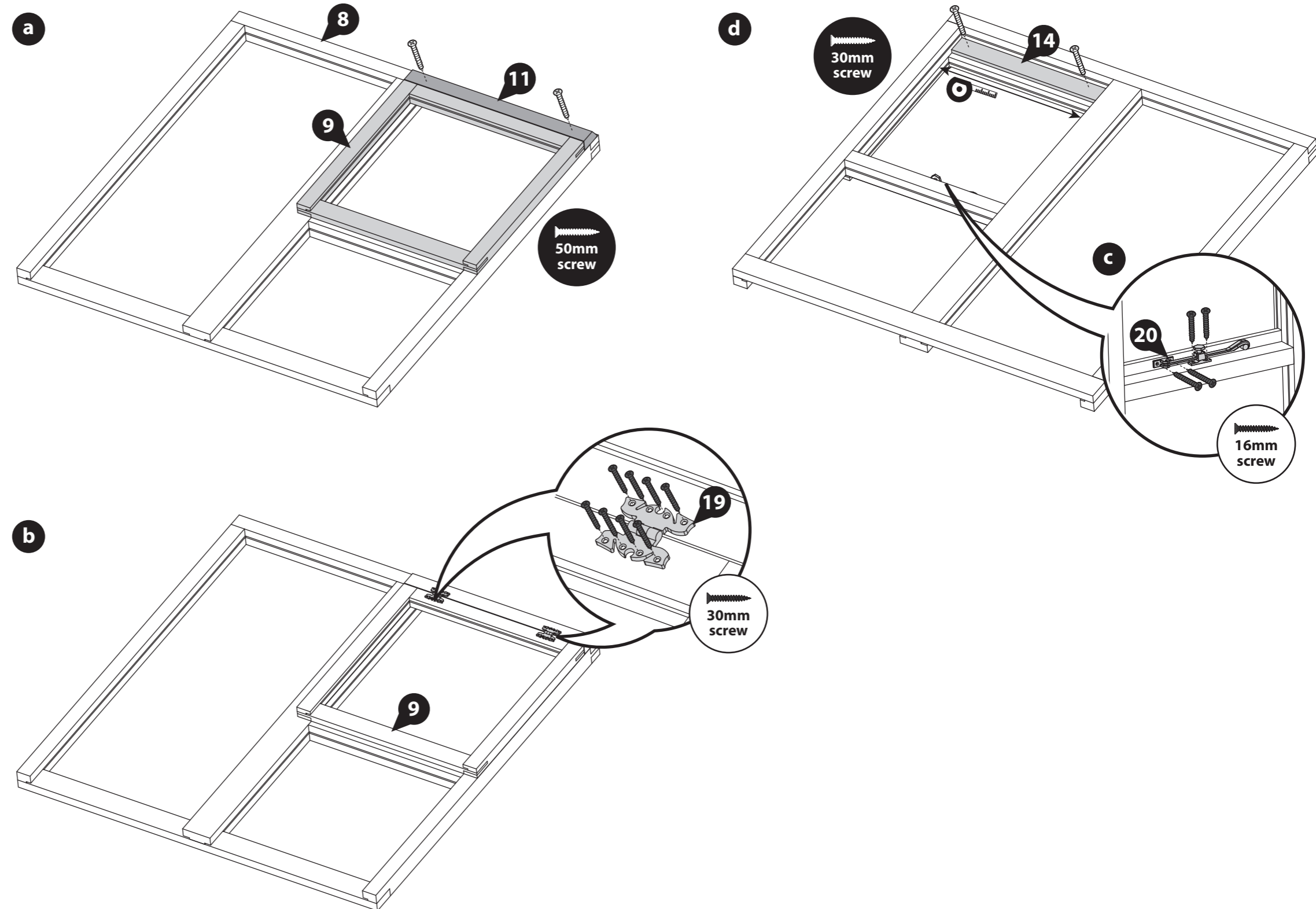

**IMPORTANT: Pre-drill before fixing screws.**

### Step 13

#### Parts Needed

Building	No. 7	No. 8	70mm screw
8x4	QTY 1	QTY 1	QTY 10

*\*Please note: The 4ft Roof Panels (No. 7 & 8) are interchangeable and can be positioned in a variety of different configurations.*

*Where possible, we recommend positioning your opening window panel as central to the greenhouse as possible, as this will allow for the best ventilation.*

**a** At one end of the building, locate one Roof Panel (No. 7 or 8) on top of the building, ensuring the Panel sits inside the Gable Top, is flush to the top of the Gable top and sits firmly on the Ridge Bar.

Position the Roof so the framing at the top end of the Roof is flush with the side of the Ridge Bar, as shown. This will ensure your building can sit flush to the surface it leans against.

*\*Make sure to position your Panels the correct way around. The stepped framing should be at the bottom, as shown.*

Fix the Roof Panel to the Gable Top using 3x70mm screws per Roof, screwing through the bottom half of the Roof framing, into the Gable framing behind. Ensure to NOT screw into the Roof channel.

**b** Continue to Position the Roof panels (No. 7 or 8) onto the building, ensuring they are flush and level. Secure them together as you go using 4x70mm screws per join in an alternating pattern.

**c** Once all the Roof Panels are positioned, secure the end Roof Panel to the Gable Top using 3x70mm screws.

*Please note: the 8x4 has been shown for illustrative purposes and may differ from your chosen building. However the process of fitting the Roof Panels is the same.*

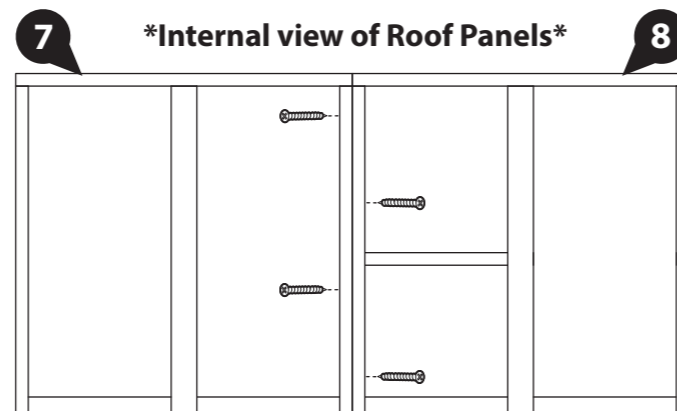
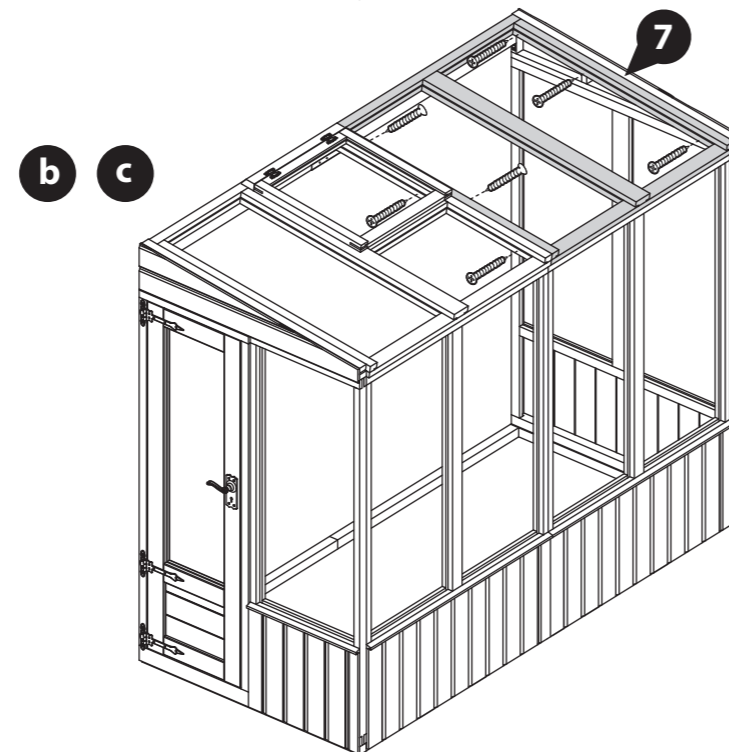
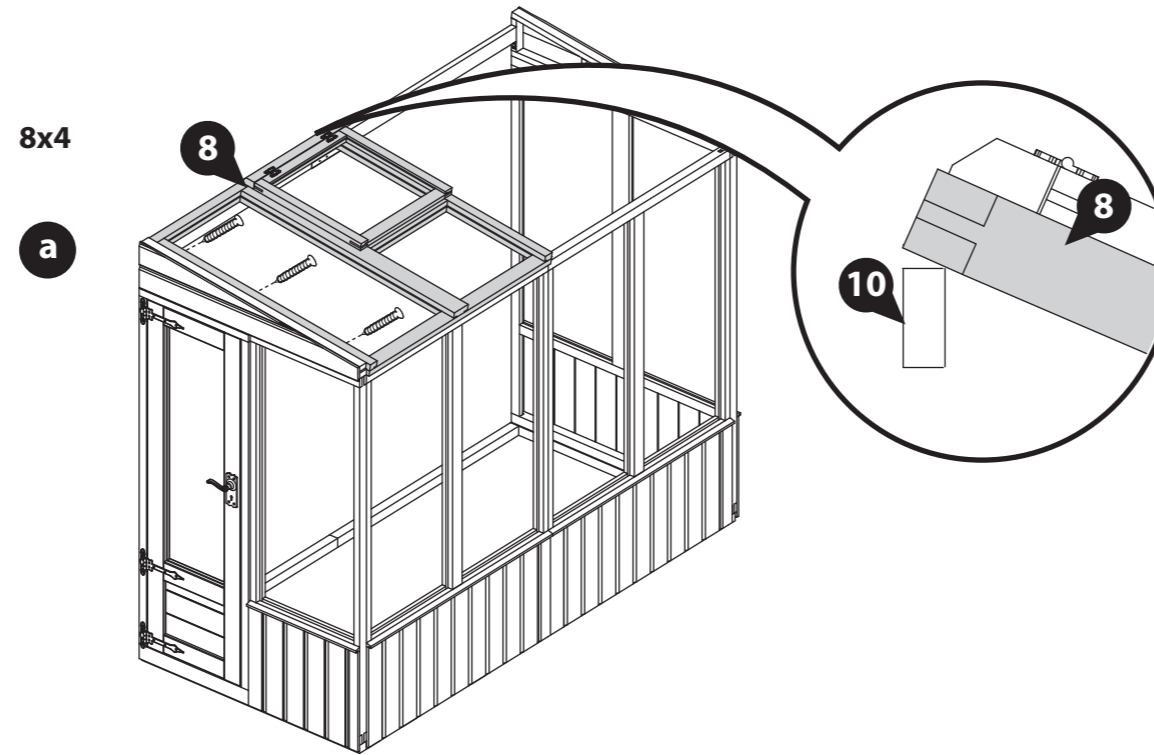



## Step 14

### Parts Needed

<b>Building</b>	<b>No. 12</b>	<b>50mm screw</b>
<b>8x4</b>	<b>QTY 1</b>	<b>QTY 5</b>

Position a Truss Frame (**No. 12**), underneath the joining Roof Panels (**No. 7 & 8**) so it is central to where they join, as shown.

Ensure to align the angled ends of the Truss Frame (**No. 12**) so they sit flush to the Wall Panel framing and flush to the Ridge Bar, as shown.

Fix the Truss Frame (**No. 12**) in place using 5x30mm screws per frame, screwing up through the Truss Frame (**No. 12**) into the Roof Panels (**No. 7 & 8**) in an alternating pattern.

It is essential that the Truss Frame (**No. 12**) and Roof Panels (**No. 7 & 8**) pull together when secured.

*Please note: the 8x4 has been shown for illustrative purposes and may differ from your chosen building. However the process of fitting the Truss Frame is the same.*

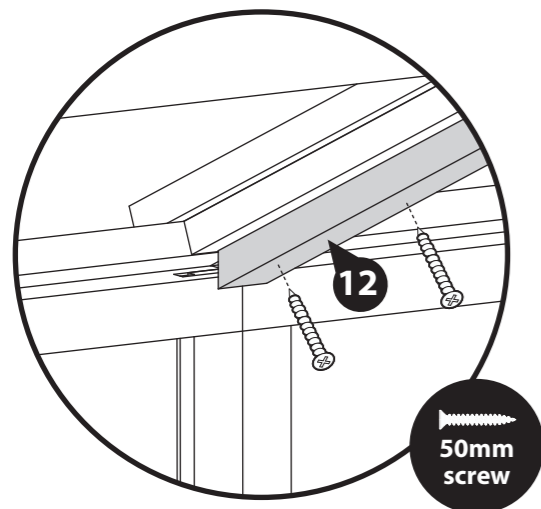

**\*Internal View\***

**IMPORTANT: Pre-drill before fixing screws.**

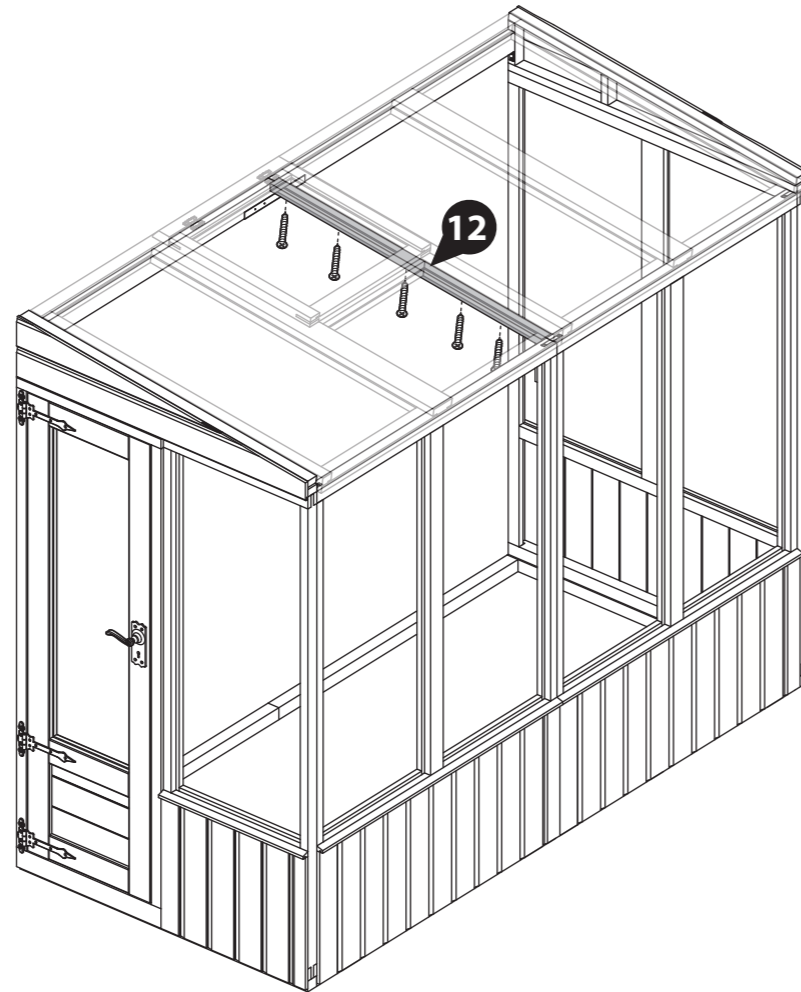

## Step 15

### Parts Needed

<b>Building</b>	<b>No. 13</b>	<b>50mm screw</b>
<b>8x4</b>	<b>QTY 1</b>	<b>QTY 2</b>

*Please note: You have been provided with two Truss Blocks (**No. 13**) however you only need to use one.*

On the walled side of the building, place the Truss Block (**No. 13**) up to the Truss Frame (**No. 12**) so the angled cut edge is facing upwards, flush to the Truss Frame (**No. 12**).

Ensure the block is also flush to the Panel uprights behind.

Fix in place using 2x50mm screws through the block into the framing behind, alternating which Panel upright you screw in to, as shown.

*Please note: the 8x4 has been shown for illustrative purposes and may differ from your chosen building. However the process of fitting the Truss Block is the same.*

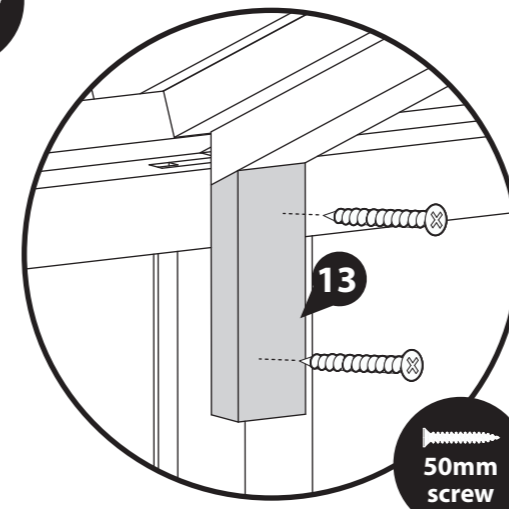

**\*Internal View\***

**IMPORTANT: Pre-drill before fixing screws.**

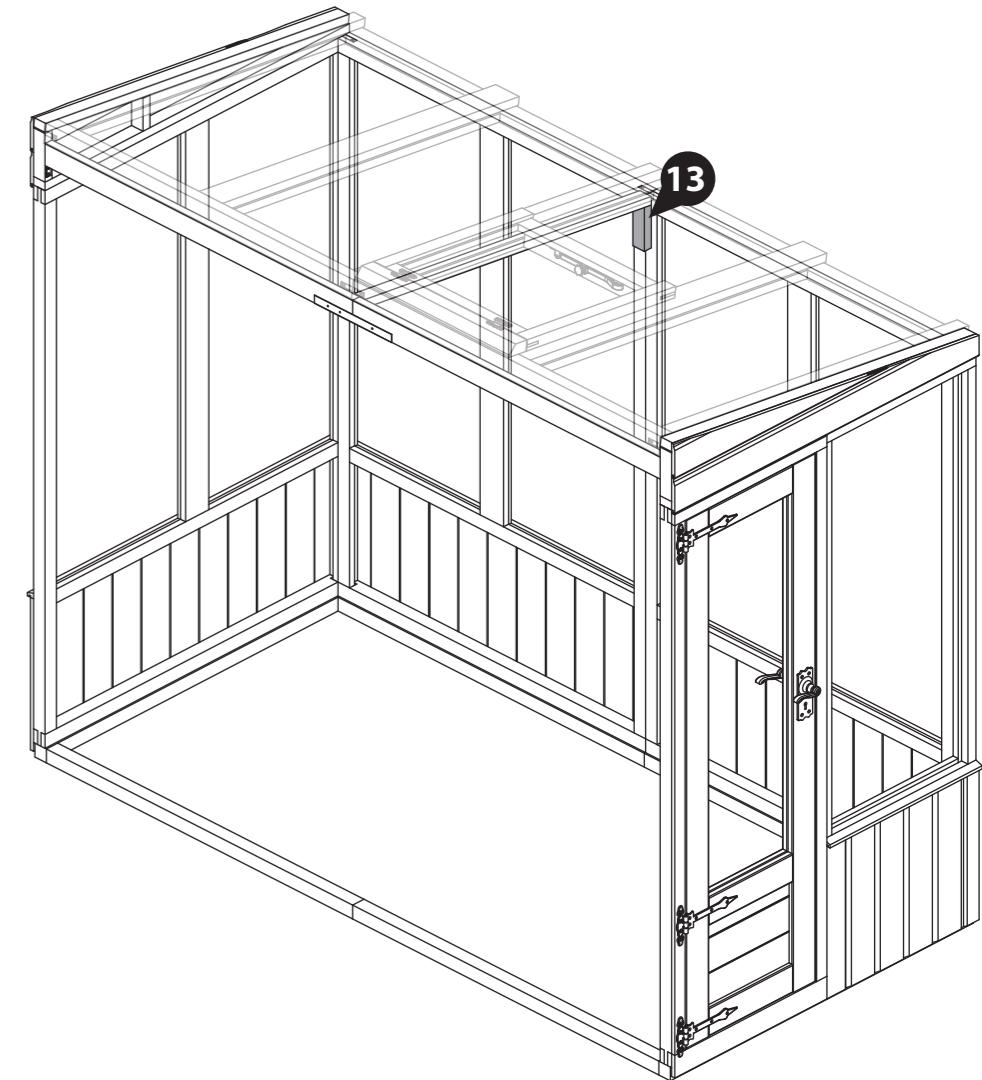

## Step 16

### Parts Needed

<b>Building</b>	<b>No. 18</b>	<b>30mm screw</b>
<b>8x4</b>	<b>QTY 2</b>	<b>QTY 8</b>

Secure the Truss Frame (**No. 12**) to the Ridge Bars (**No. 10**), by placing one Corner Brace (**No. 18**) either side of the Truss Frame. Ensure they are flush to both the Truss Frame and Ridge Bars, as shown.

Fix in place using 4x30mm screws per Corner Brace.

*Please note: the 8x4 has been shown for illustrative purposes and may differ from your chosen building. However the process of fitting the Corner Braces is the same.*

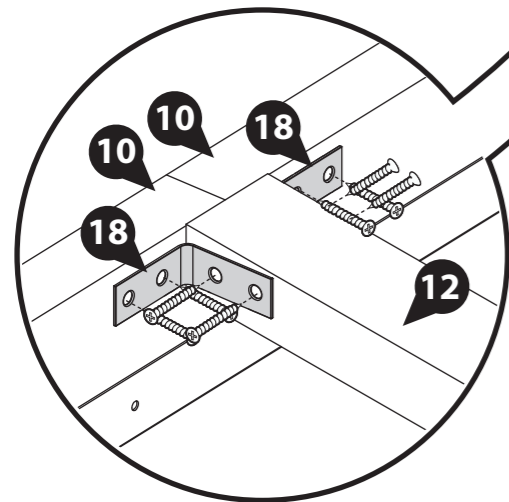

**IMPORTANT: Pre-drill before fixing screws.**

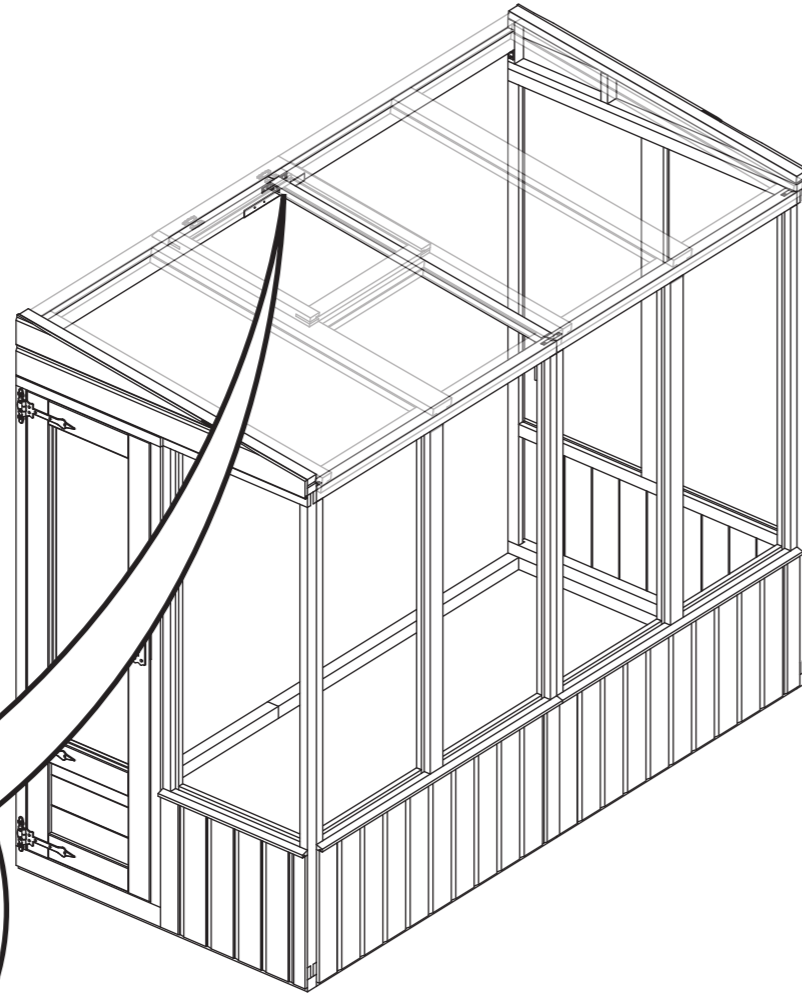

## Step 17

### Parts Needed

<b>Building</b>	<b>50mm screw</b>
<b>8x4</b>	<b>QTY 8</b>

Make sure the building is square by measuring from corner to corner and comparing the measurements. If the measurements are equal, the building is square, if not, adjustments may be required.

Once square, secure the Roofs in place using 50mm screws, screwing down through the Roof framing into the Panel framing below.

Ensure the screws are countersunk to avoid interference when glazing.

*Please note: the 8x4 has been shown for illustrative purposes and may differ from your chosen building. However the process of fixing the Roof is the same.*

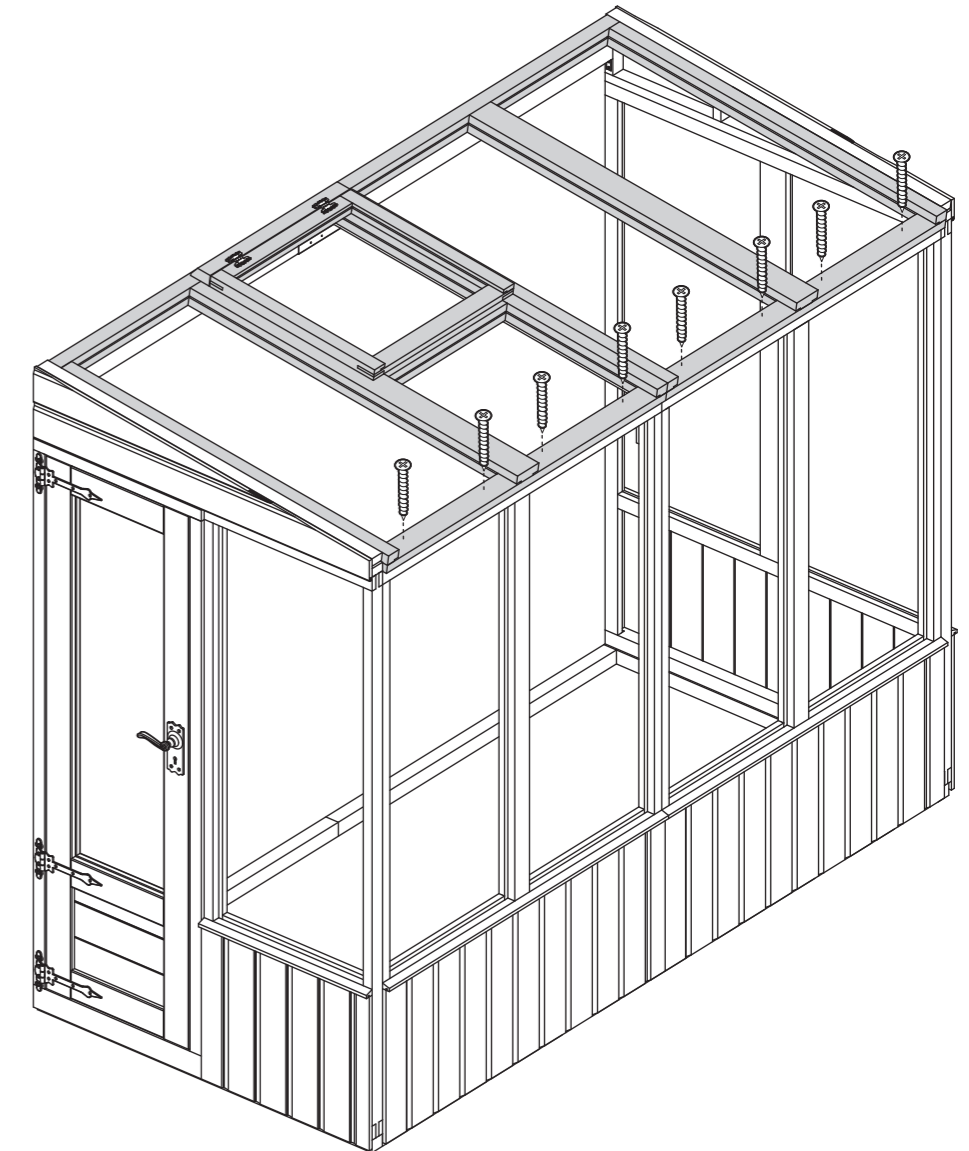
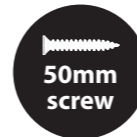

**IMPORTANT: Pre-drill before fixing screws.**

**Step 18** **Parts Needed**

<b>Building</b>	<b>70mm screw</b>
<b>8x4</b>	<b>QTY 13</b>

Once the Roof is fixed, secure the Panels to the base frame using 70mm screws, screwing down through the Panel framing into the base frame below.

*Please note: the 8x4 has been shown for illustrative purposes and may differ from your chosen building. However the process of fixing the Panels is the same.*

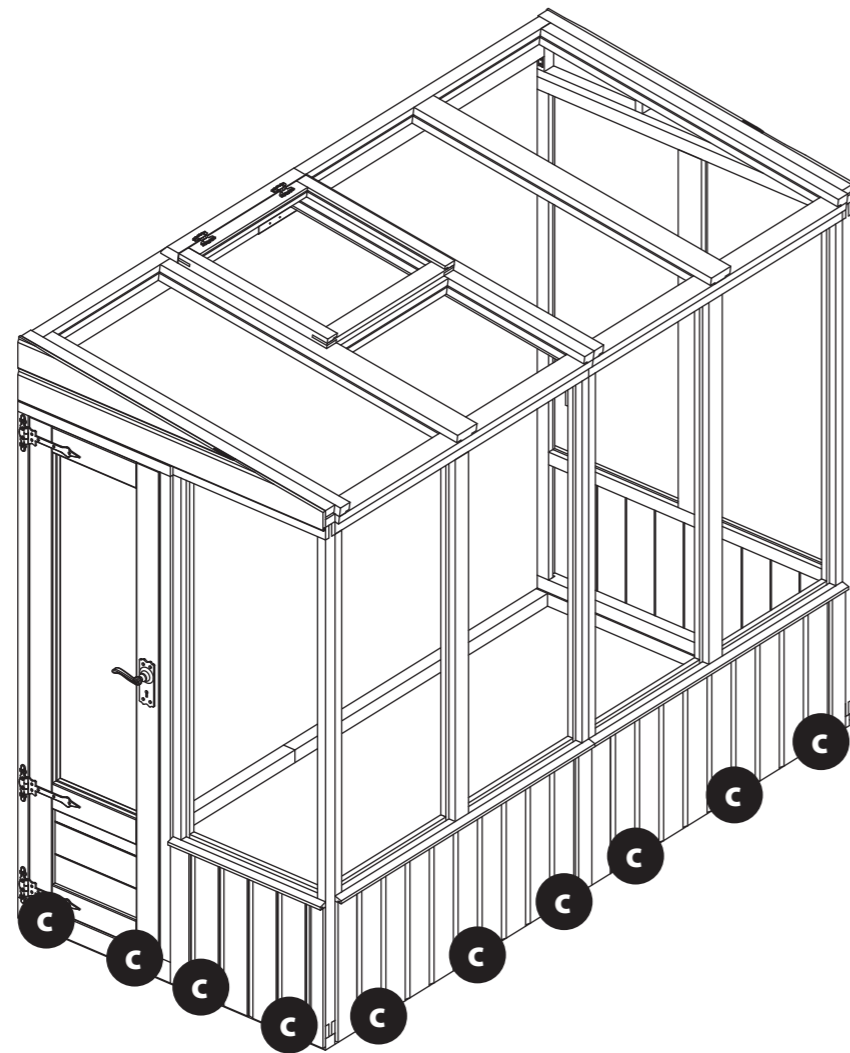
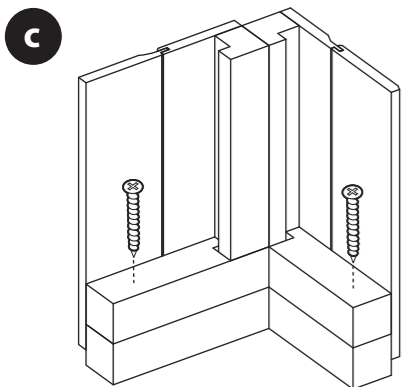

**IMPORTANT: Pre-drill before fixing screws.**

**Step 19** **Parts Needed**

<b>Building</b>	<b>No. 14</b>	<b>30mm screw</b>
<b>8x4</b>	<b>QTY 3</b>	<b>QTY 12</b>

*Please note: You have been supplied with a total of six Cover Trims (No. 14) however you may not need to use them all.*

- a** At each corner and Panel join, use a tape measure to measure the distance the Cover Trim needs to fill e.g, from the bottom of the Panel to the top of the Panel or from the top of the cill to the top of the panel.

Mark the measurements onto the Cover Trims (No. 14) and cut to size if required.

*Please note: For the panel joins, one Cover Trim can be cut to create both the top and bottom. Ensure to use all of one Cover Trim where possible before cutting a new one. Do not dispose of off-cuts until the building is fully constructed as they may be needed in another step.*

- b** Locate the Cover Trims (No. 14), over each Panel join and corner, ensuring they sit centrally over the joins and flush to the Panel cladding at the corners.

Secure in place using 3x30mm screws per Cover Trim, alternating fixing into each Panel when over a join.

*Please note: the 8x4 has been shown for illustrative purposes and may differ from your chosen building. However the process of fitting the Cover Trims is the same.*

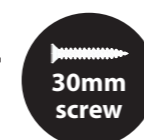

**IMPORTANT: Pre-drill before fixing screws.**

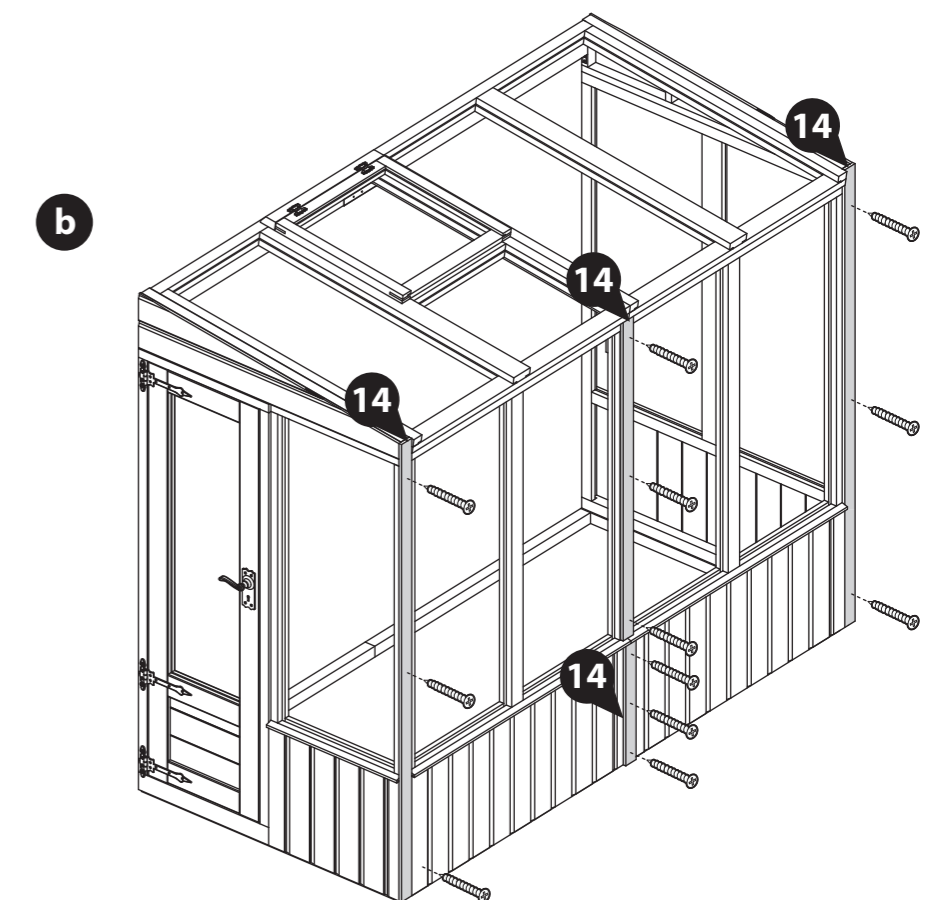
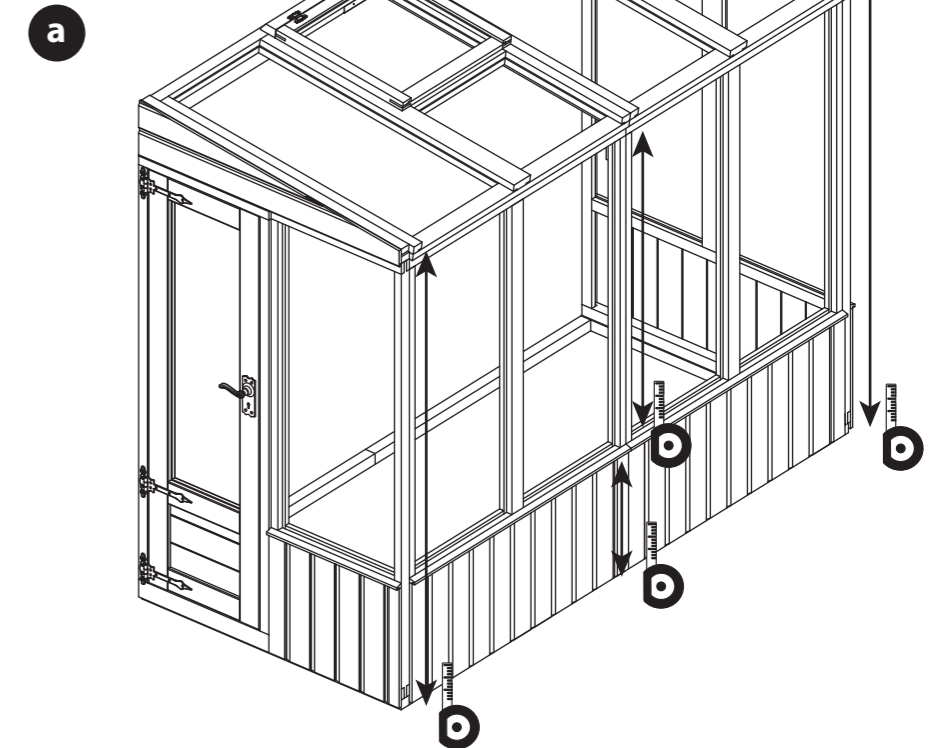

<b>Step 20</b>	Parts Needed	
	<b>Building</b>	<b>No. 14 30mm screw</b>
	<b>8x4</b>	<b>QTY 1 QTY 10</b>

**Additional Height upgrade only.**  
 If you have not purchased the Additional Height upgrade, then please skip to the next step (Step 21).

**a** Where each 2ft Height Extension Panel (No. 4) joins to the next, use a tape measure to measure from the top of the panel to the bottom, as shown.

Mark the measurements onto the Cover Trims (No. 14) and cut to size if required.

*Please note: Ensure to use all of one Cover Trim where possible before cutting a new one. You may have a suitable size remaining from the previous step. Do not dispose of off-cuts until the building is fully constructed as they may be needed in another step.*

**b** Locate the Cover Trims (No. 14), over each Panel join, ensuring they sit centrally over the joins.

Secure in place using 2x30mm screws per Cover Trim, alternating fixing into each Panel.

*Please note: the 8x4 has been shown for illustrative purposes and may differ from your chosen building. However the process of fitting the Cover Trims is the same.*



**IMPORTANT: Pre-drill before fixing screws.**

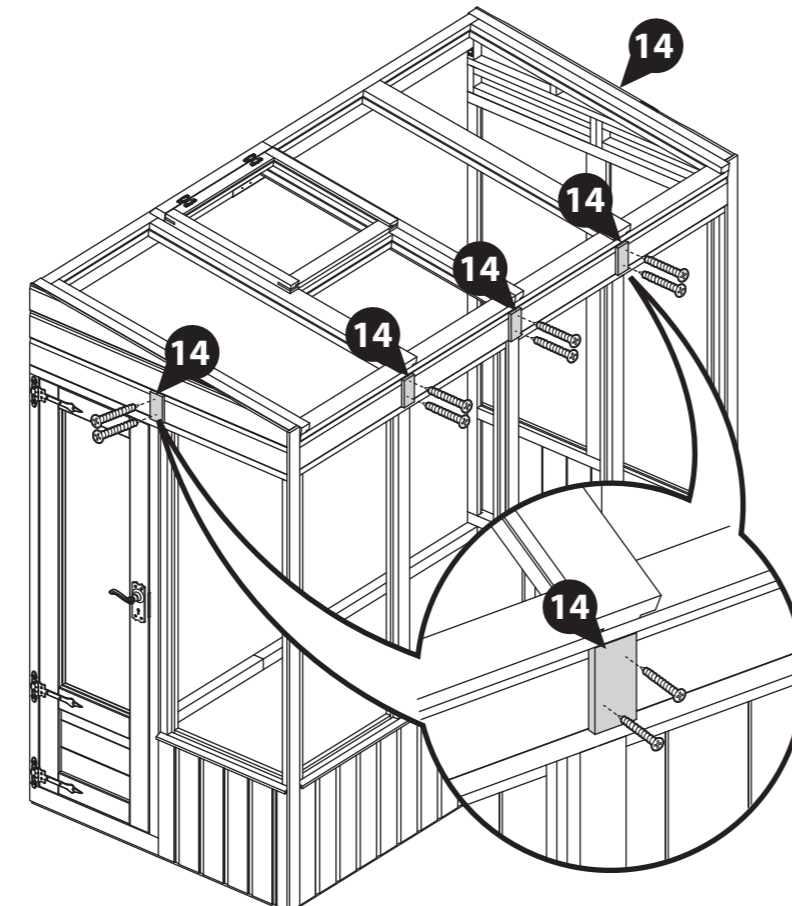
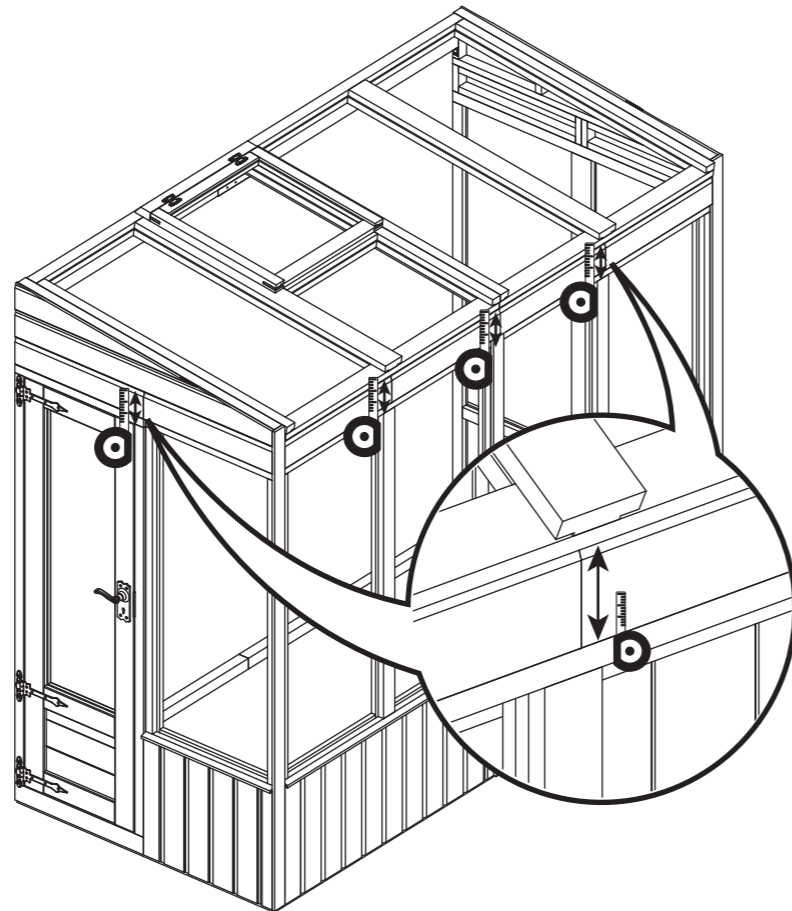

<b>Step 21</b>	Parts Needed	
	<b>Building</b>	<b>No. 15 30mm screw</b>
	<b>All sizes</b>	<b>QTY 2 QTY 8</b>

**a** At each end of the building, use a tape measure to measure the distance from the top of the Roof Panel to the bottom, as shown.

Mark the measurements onto two Roof Trims (No. 15) and cut to size.

**b** Locate the Roof Trims (No. 15), over the joining Roof and Gable Top framing, ensuring they sit flush to the Gable cladding, as shown.

Secure in place using 4x30mm screws per Roof Trim.

*Please note: the 8x4 has been shown for illustrative purposes and may differ from your chosen building. However the process of fitting the Roof Trim is the same.*



**IMPORTANT: Pre-drill before fixing screws.**

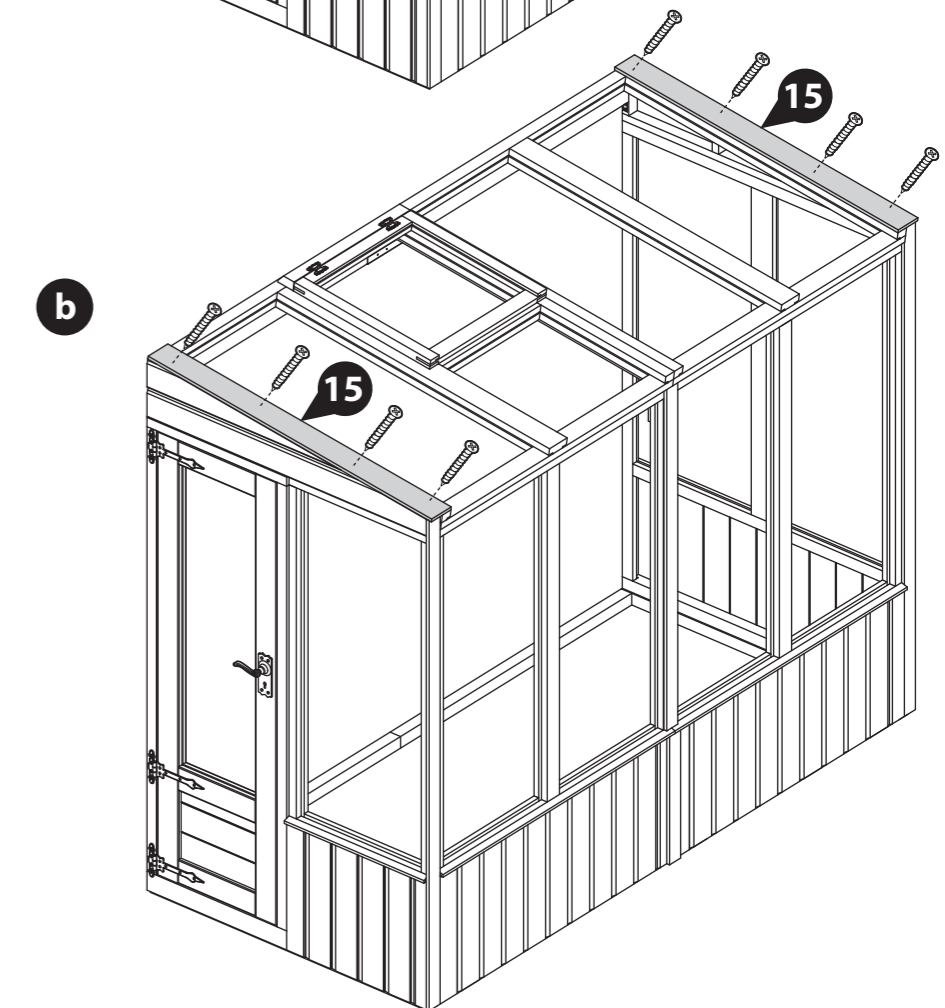
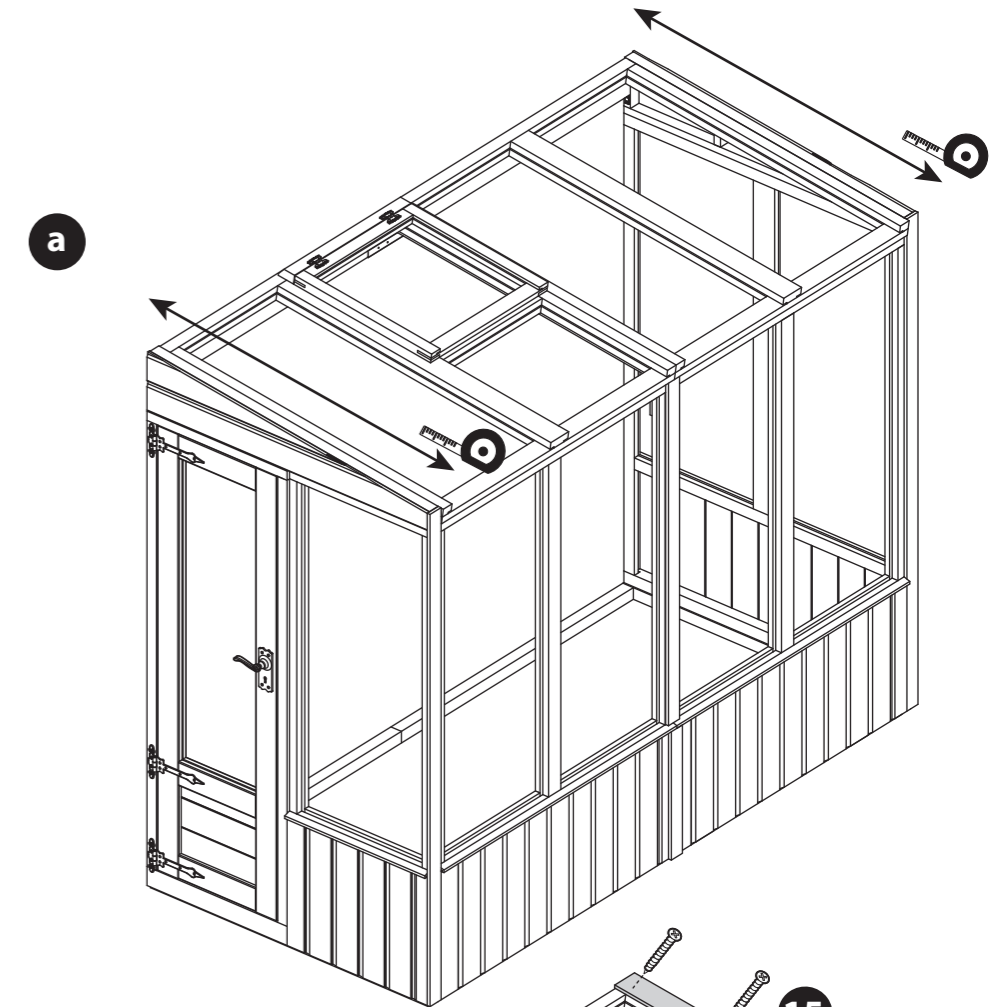

Step 22			Parts Needed	
Building	No. 16	40mm screw		
8x4	QTY 2	QTY 8		

**IMPORTANT: Pre-drill before fixing screws.** **Step 23**

**a** At each end of the building, use a tape measure to measure the distance from the top of the roof Panel to the bottom of the Roof Panel, as shown.

Mark the measurements onto two Fascias (No. 16) and cut to size.

**b** Position the Fascias onto the ends of the building, ensuring they are flush and level.

Secure in place using 4x40mm screws per Fascia.

*Please note: the 8x4 has been shown for illustrative purposes and may differ from your chosen building. However the process of fitting the Fascias is the same.*

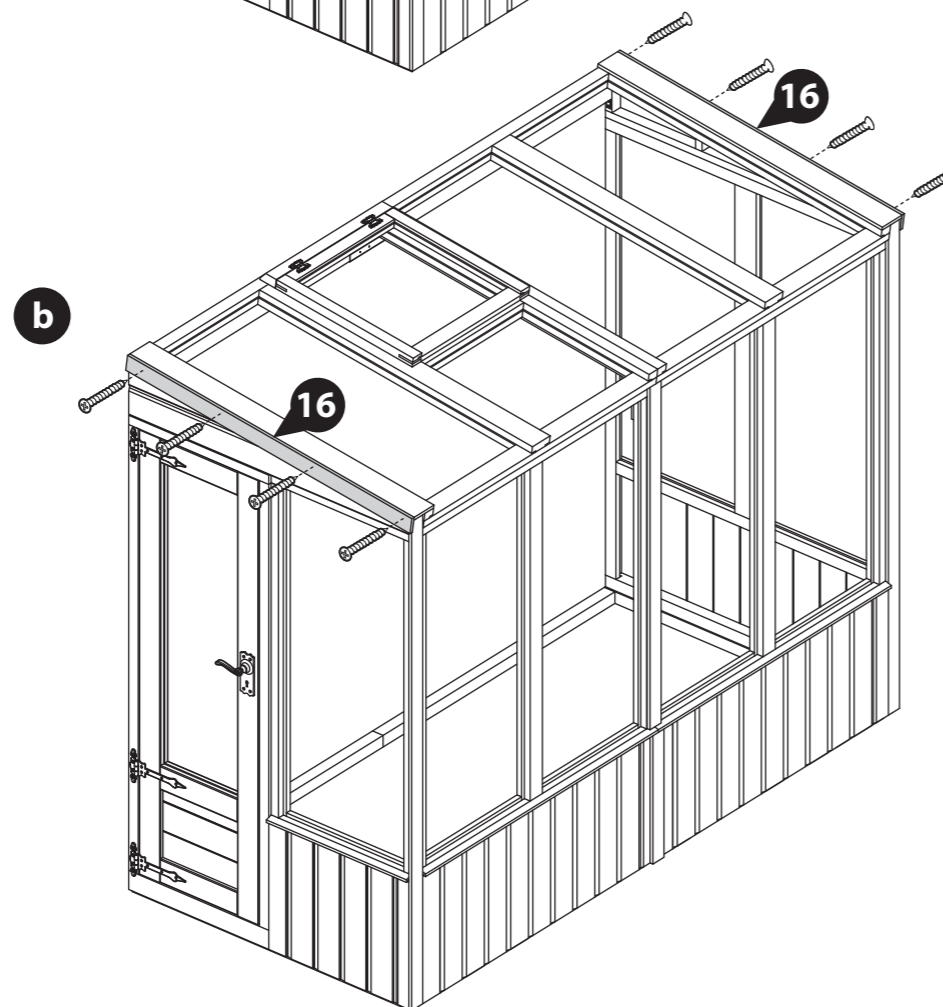
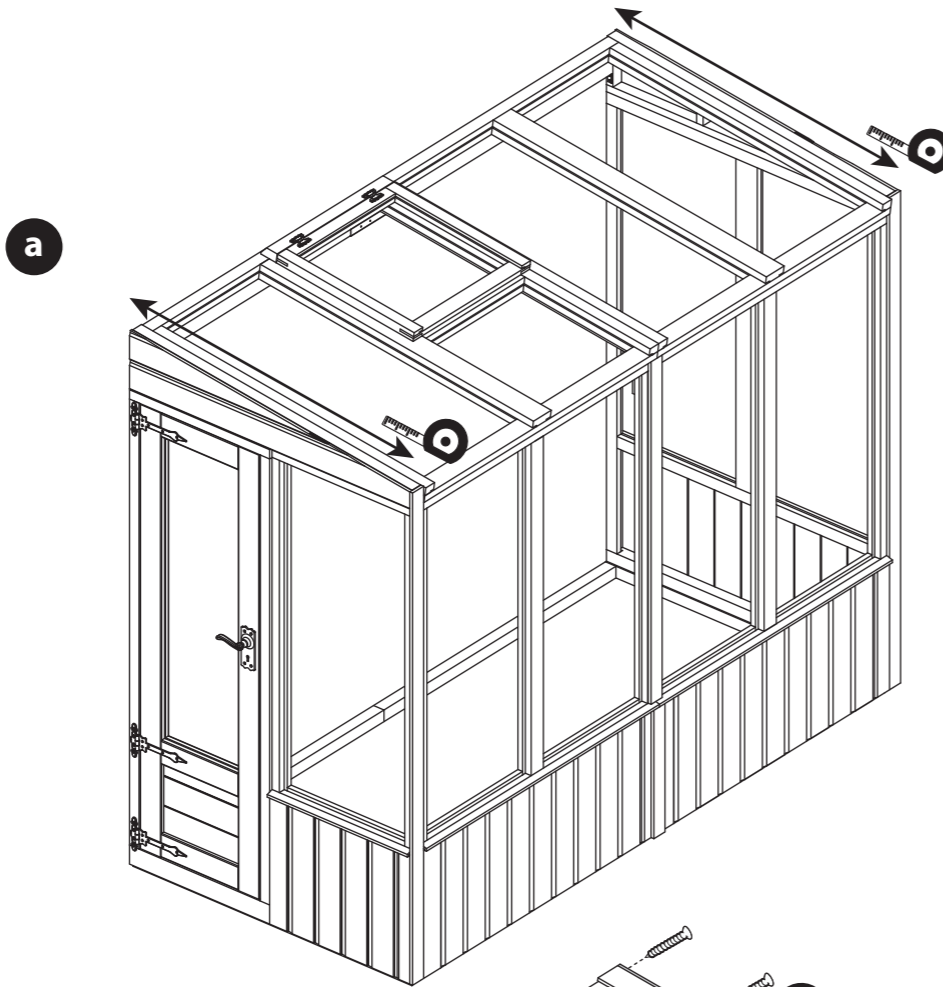

Once constructed, apply a preserving treatment and a waterproofing treatment to your garden building as soon as possible. This will help to protect your building and prevent decay.

**\*\*Make sure to treat any loose timber components still required for the glazing of your building - such as beading strips.**

See page 23 for a full guide and instructions.

*Please note: the 8x4 has been shown for illustrative purposes and may differ from your chosen building. However the process of treating the building is the same.*



Apply treatment.

**Next steps...**

Once your Greenhouse is constructed and treated please refer to the 'Panel Glazing' manual provided for steps on how to fit the glazing into each of your panels.

***This guide must be followed to complete the construction of your Greenhouse.***

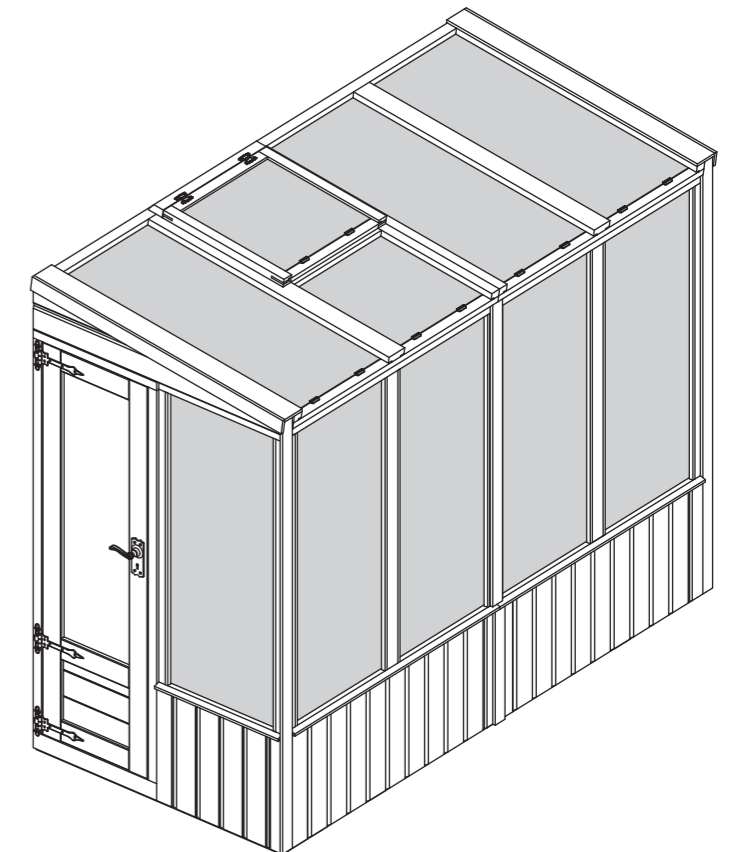
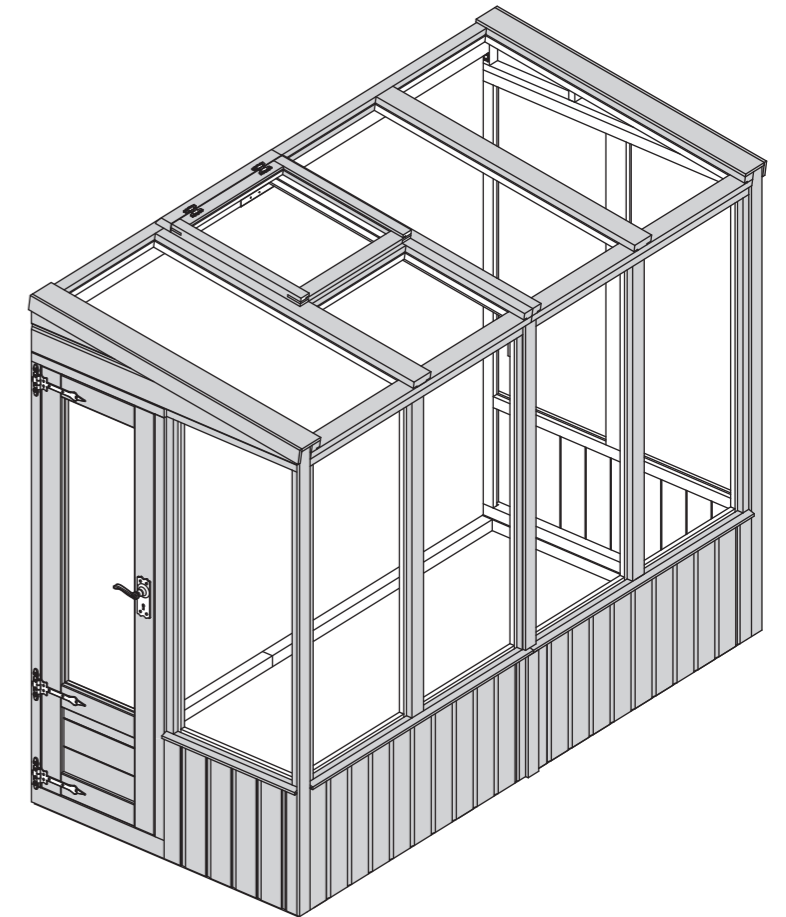

**We do not include wall fixings with this product due to wall construction materials varying from property to property. If you are unsure on the fixings you require, we recommend that you consult with your local builders merchant or knowledgeable DIY store.**



## **LEAVE US A REVIEW...**

Want to share your experience with us?  
Leave us a review on Feefo, TrustPilot or Google.

Your reviews help other people find and trust our business, as well as helping to play an important role in our growth and improvement!

## TREATING YOUR GREENHOUSE

Preservation of wood that's outdoors is vital. A little early care will help protect your greenhouse, improve its appearance and ensure maximum longevity. Insects, moisture, salt, and changing weather can have dramatic effects on the stability and appearance of your greenhouse. Once your greenhouse is installed, you've checked it over and you're happy with it, you can take a few basic precautions to prepare it for the elements. Treating your greenhouse helps prevent decay and, by repelling water, discourages the growth of moulds and fungi that could jeopardise the structural integrity of the wood.

**Dip Treated Greenhouses** - Require a preservative treatment to protect against rot and decay and a waterproof treatment to prevent water ingress



**ANY QUESTIONS?**  
Scan the QR code to contact us via our customer portal.

To apply a preservative and water proofing treatment (pressure treated products do not require a preserver), follow the manufacturer's instructions but in principle, stick to the following steps:

- ✓ Weather permitting, ensure to treat your greenhouse within 14 days of installation.
- ✓ Wear latex or rubber gloves, eye protection and (if spraying) a mask.
- ✓ Prepare the wood, by sanding down any ridges or inconsistencies in the wood, smoothing out knots and end-cuts.
- ✓ Choose a dry day to treat your greenhouse. If you're spraying rather than brushing paint on, avoid a windy day.
- ✓ Be sure you can safely reach all the sections you need to paint - and if you need a ladder, make sure it's safely positioned before climbing. Lay dust sheets around to avoid paint splatters on your base or surrounding plants.
- ✓ Tape around windowpanes to avoid smears when you're painting the frames.
- ✓ Keep pets and small children out of the way. The last thing you want is to have fur on your garden building paint, or little painted footprints all over your garden and home.
- ✓ Fill any gaps in the greenhouse's body with caulk or wood filler to prevent water and draughts getting in. Silicone based caulk is flexible and will move with the timber when temperature and humidity change. Allow to dry completely before treating. A handy tip for finding gaps is to go into your greenhouse and look for light leaking through joins and frames. If light gets in, then so will water.
- ✓ Liberally apply at least two coats of the treatment products with a brush or spray, taking care to allow the first coat to completely dry before applying the second.
- ✓ Make sure the solution permeates the whole of the surface area, especially around natural cracks, end cuts and nail/screw holes.



APPLY WOOD TREATMENT  
**IMMEDIATELY**  
AFTER ASSEMBLY



## 1 Perimeter

---

Check around the perimeter of your product to ensure there are not trees or plants that are in contact with or overhanging the building. This can affect airflow and overhanging trees, or branches can damage the roof, it is advised to keep plants at a distance.

## 2 Repair

---

Inspect the interior and exterior of the product to look for splits, cracks, and holes. Although this is a natural occurrence it can be prevented. A wood filler can be used to close the splits, cracks, and holes.

## 3 Roof

---

Check your roof regularly for tears, splits, damaged wood and fallen debris. If you notice any of this immediate repair is critical.

## 4 Doors & Windows

---

Expansion and contraction can cause doors and windows to stick or become difficult to open. Small adjustments to the hinge position can be made to the doors and windows to allow free movement.

## 5 Oil

---

Hinges can seize up over time, apply lubricant to the hinges and locks annually.

## 6 Screws & Bolts

---

It is advised to check all screws and bolts and tighten any loose you might find. For log cabins specifically the storm braces will require loosening. During humidity and temperature changes (seasons) to allow expansion and contraction to prevent gaping, twisting, popping, and warping.

## 7 Wash

---

At least once a year, give the outside of you greenhouse a good wash, to remove cobwebs, leaves, or any other dirt that may accumulate on the exterior.

## 8 Airing

---

Airing your product regularly prevents the build up of condensation which can cause the timber to warp, bow, boards to pop, distortion, rot and mould. Condensation can build up over time or daily, it is caused by a rise and fall in temperature.

Excessive moisture levels within your building can cause water to collect on the roofs, walls and floors internally. Leaving doors and windows open regularly can help combat the natural moisture build up.

## 9 Clean & Tidy

---

It is good practice to clean the inside and outside of your product regularly. Clear out the contents, sweep the floor, remove dirt and cobwebs. Check for areas of damp and investigate the cause to remove and prevent future occurrences. Check the ground around your product for build up of debris such as leaves, remove and ensure there is clear ventilation underneath the floor.



All our greenhouses have been designed and manufactured with care and attention to be the perfect addition to your outdoor space. To ensure you do get the best out of your new greenhouse and to increase the longevity we advise that you follow the product instructions and our manufacturer's recommendations as detailed below. Thank you for choosing a Mercia Garden product!

## 1 Choosing the most suitable location for your greenhouse...

A minimum of 60cm should be left around the perimeter of your greenhouse to allow access for maintenance, annual treatment and to allow air flow around the building.

Where possible you should avoid placing your greenhouse underneath large trees to prevent the tree causing damage to the building.

## 2 Preparing the base for your garden building...

All our buildings must be built on a firm, level base to ensure the longevity of the building and prevent the wood from distorting. We recommend either concrete, concrete slabs or a wooden base, such as our 'Portabase'.

The base should be slightly smaller than the external measurement of the building, i.e. the cladding should overlap the base, creating a run off for water and preventing water from pooling underneath the building.

We also recommend that the floor of the greenhouse is a minimum of 25mm above the surrounding ground level to avoid flooding.

## 3 After installation...

Once your greenhouse has been installed, it will need to be treated within 14 days (weather permitting) and then annually to prevent the timber from deteriorating and to waterproof it. This is required to maintain the anti-rot guarantee.

Dip Treated greenhouses - Require a preservative treatment to protect against rot and decay

We also recommend using a silicon sealant around the glazing on the inside and outside of the windows and roofs as soon as possible after assembly and treatment to fully seal the windows.

Roofing coverings should be checked annually and replaced or fixed accordingly.

## 4 General maintenance and wood characteristics

As wood is a natural material it may be affected by the following:

**Shrinkage and warping** - The timber used in the construction of your greenhouse will have retained some of its natural moisture content. The moisture content of the timber will vary, depending upon prevailing environmental conditions, which will result in the components either naturally expanding or contracting. As the components dry out, shrinkage may occur. A good waterproofing treatment from the start is the best protection to minimise the effect of moisture loss/intake.

In extended periods of very warm weather getting some moisture to the building will help the overall balance. You can do this by spraying it down lightly with a garden hose. In contrast, after snow fall try to remove the snow as best as possible from the roof to prevent moisture intake and to remove the extra weight.

**Top tip** - using a garden brush will help you to reach the highest part of the building to remove snow and any debris left from bad weather.

**Damp and mould** - During the winter months, cold and damp conditions can result in an increased amount of moisture within your greenhouse, especially when used infrequently. Condensation can form on the timber and other items stored within your greenhouse. If left this moisture is likely to cause mould and mildew.

To prevent the build-up of moisture, we recommend leaving the door or windows of your greenhouse open from time to time, to allow the fresh air to circulate. We also advise against storing wet or damp items in your greenhouse as this will also increase the level of moisture in the building. If mould or mildew does start to form within your greenhouse we recommend using an anti-mould cleaner to remove it and to prevent it spreading, which if left untreated could permanently damage your greenhouse.

**Splits, cracks and knots** - You may notice small splits and cracks in some components or holes may appear where knots shrink and fall out. This will not affect the structure of your greenhouse however, if you wish to fill them this can be easily done using any good quality wood filler.

**Sap** - is naturally occurring in wood and may appear in some boards of your greenhouse. If you wish to remove the sap, we advise waiting until it is dry and then using a sharp knife to carefully remove it. If the removal of the sap causes a hole in the timber, we recommend using a good quality wood filler to fill it.

For more handy hints and tips on how to care and maintain your greenhouse please refer to the MGP Customer Portal at [www.mgplogistics.co.uk](http://www.mgplogistics.co.uk)



### Any further questions?

Contact our Customer Service Team via the MGP Customer Portal at: [www.mgplogistics.co.uk](http://www.mgplogistics.co.uk)

## 1

### Manufacturer's Warranty

All Mercia Garden Products are supplied with a 1 year warranty on all parts against manufacturing defects.

This warranty does not cover movement, warping or splitting of timber products over time.

This warranty will be voided if any of the following occur:

1. The building has been customised or modified/adapted in any way.
2. The person claiming is not the original purchaser of the building.
3. Any damage has been caused by or as a result of misuse.
4. The building has not been maintained and cared for in accordance to our advisories and manufacturer's recommendations.
5. The building has not been treated annually or as per the manufacturer's recommendations, please ensure receipts are kept to validate this claim.
6. The building has not been erected, fitted or installed as per the supplier instructions.
7. The building has not been erected on a suitable sized firm flat, solid level concrete/slab base or placed on pressure treated bearers.
8. The building is or has been placed with 2 feet (600mm) of any obstructions (walls, trees, plants, fences etc.) which can allow moisture to penetrate the timber.
9. The roofing felt has been incorrectly fitted or damaged, allowing water ingress, or has not been properly maintained.
10. Any windows and joints have not been sealed, inside and out, with silicone or other watertight sealant.
11. Any timber has been cut, pierced or drilled without subsequent application of approved cut-end treatment.

REGISTER FOR YOUR  
**10 YEAR**  
**ANTI-ROT**  
GUARANTEE TODAY



[www.mgplogistics.co.uk](http://www.mgplogistics.co.uk)

## 2

### Anti-rot Guarantee

Mercia Garden Products offer a 10 year anti-rot guarantee on all dip treated (a preparatory treatment) and 15 years on all pressure treated products. This guarantee covers solid timber against rot, decay, blue stain and insect attacks.

To validate the guarantee, the building must be treated (as detailed within manufacturer's recommendations) within 14 days (weather permitting) of assembly and annually thereafter.

This guarantee does not cover movement, warping or splitting of timber products over time.

This guarantee will be voided if any of the following occur:

1. The building has been customised or modified/adapted in any way.
2. The person claiming is not the original purchaser of the building.
3. Any damage is caused by or as a result of misuse.
4. The building has not been maintained and cared for in accordance to our advisories and manufacturer's recommendations.
5. The building has not been treated annually or as per the manufacturer's recommendations, please ensure receipts are kept to validate this claim.
6. The building has not been erected, fitted or installed as per the supplier instructions.
7. The building has not been erected on a suitable sized firm flat, solid level concrete/slab base or placed on pressure treated bearers.
8. The building is or has been placed with 600mm of any obstructions (walls, trees, plants, fences etc.) which can allow moisture to penetrate the timber.
9. The roofing felt has been incorrectly fitted or damaged allowing water ingress, or has not been properly maintained.
10. Any windows and joints have not been sealed, inside and out, with silicone or other watertight sealant.
11. Any timber has been cut, pierced or drilled without subsequent application of approved cut-end treatment.