

12PTMBHP0404RP-V1

4M X 4M PRESSURE TREATED MATCHBOARD HIP ROOF PACK.

BEFORE YOU START PLEASE READ INSTRUCTIONS CAREFULLY

- Check the pack and make sure you have all the items listed in the parts list provided.
- When you are ready to start, make sure you have the right tools at hand (not supplied - see the equipment list on next page).
- Ensure you have enough time to build the product.

LOCATION FOR YOUR GARDEN STRUCTURE

A minimum of 600mm should be left around the perimeter of your garden structure to allow access for maintenance, annual treatment and to allow air flow around the structure.

TIMBER

As with all natural materials, timber can be affected during various weather conditions. For the duration of heavy or extended periods of rain, swelling of the wood panels may occur. Warping of the wood may also occur during excessive dry spells due to an interior moisture loss. Unfortunately, these processes cannot be avoided but can be helped. It is suggested that the outdoor structure sprayed with water during extended periods of warm sunshine and sheltered as much as possible during rain or snow.

Once your garden structure has been installed it will need to be treated within 14 days (weather permitting) and annually to prevent the timber from deteriorating and to waterproof it. This is required to maintain the anti-rot guarantee.

Dip Treated buildings - Require a preservative treatment to protect against rot and decay and a waterproof treatment to prevent water ingress.

Pressure Treated Products - Require a waterproof treatment to prevent water ingress

ANCHORING OPTIONS

When thinking about where the structure, ensure that there will be access to all sides for maintenance work and annual treatment.

There are a number of techniques for anchoring the structure to the ground, the most suitable option will depend on the ground conditions and surrounding area. These options are but not limited to, concreting the posts into the ground, steel post supports, ground screws, fixing to decking, metal footings and brackets. When deciding upon the most suitable anchoring option for you take advice from your local DIY store.

Whilst all products manufactured are made to the highest standards of safety and in the case of children's products independently tested to EN71 level, we cannot accept responsibility for your safety whilst erecting or using this product.



x2 All product's should be erected by two adults



Winter = High Moisture = Expansion
Summer = Low Moisture = Contraction



2mm Drill bit

For ease of assembly, you **MUST** pilot drill all screw holes and ensure all screw heads are countersunk.



CAUTION
Every effort has been made during the manufacturing process to eliminate the prospect of splinters on rough surfaces of the timber. You are strongly advised to wear gloves when working with or handling rough sawn timber.



For ease of assembly use a rubber mallet to fit notched timbers together. Do NOT use a heavy hammer.



Ensure to measure and check before cutting boards.

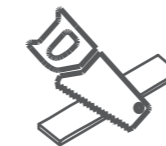

It is advisable to use a hand saw when cutting roof and floor boards.



To ensure timbers are even, use a spirit level to check each layer has been installed correctly.

Screws & Nails



Measure overall length

Bolts



Measure under the head

To identify the fixings required for each step use a measuring tape.

Pressure Treated Timber

Your product has been pressure treated.

Pressure treating is a chemical process which helps to protect wood against adverse weather which could lead to rot or insect damage.

The most common chemicals used to pressure treat wood are **Alkaline Copper Quaternary (ACQ)**, **Copper Azole (CA)**, and **Micronized Copper Quaternary (MCQ)**.

Safety: Always wear gloves, eye protection and a dust mask when handling wood. Due to chemicals in pressure treated wood, never burn its sawdust or scraps; instead dispose in a landfill.

In all instances for assistance with your product, please contact customer care on :
01636 821215 or customerservice@merciagardenproducts.co.uk

Mercia Garden Products Limited,
Sutton On Trent,
Newark,
Nottinghamshire,
NG23 6QN



REGISTER FOR YOUR
ANTI-ROT
GUARANTEE TODAY

PLEASE SCAN HERE:



TO DO LIST

- Find a suitable location to build *(see front cover for further information).*
- Prepare area, anchor posts *(see front cover and pre-assembly for further information).*
- Check the base is flat, level, clear of debris and has 60cm clearance on all sides.
- Check you have the required equipment.
- Check you have all the product items listed *(if you have missing or damaged parts please contact the customer services department, see front cover for contact details).*
- Install the product as per the step by step instructions within this pack.
- Prepare the product ready for treatment.
- Apply a waterproofing treatment within 14 days *(weather permitting)* of installation.
- Register for your anti rot guarantee *(scan the QR below).*
- Tidy the build area and dispose of any remaining parts responsibly.
- Maintain your structure *(see the manufacturers recommendations at the back of this pack).*

EQUIPMENT LIST

- Hammer
- Mallet
- Flat Head Screwdriver
- Drill
- Drill Bit Set
- Phillips and Slotted Bit Sets
- Tape Measure
- Hand Saw
- Spirit Level
- Ladders/Steps
- Stanley Knife/Cutting Tool
- Sand Paper
- Gloves
- Silicone (For Windows Only)
- Wood Filler (Optional)
- Timber Water Proofing Treatment
- Treatment Mixing Stick
- Paint Brush/Sprayer/Roller

NEED EXTRA SUPPORT

If you are unsure that your base preparation will be suitable, please contact us on 01636 821215 to discuss this further.

Alternatively, you can visit our website or MGP Logistics Online Portal for some further sheducation.

Website:

<https://www.merciagardenproducts.co.uk/sheducation>

MGP Logistics Online Portal:

<https://www.mgplogistics.co.uk/>

Here you will find plenty of useful information that'll help with most pre-installation and maintenance queries.



ANY QUESTIONS?
CONTACT US ON
01636 821215

NOTES

Before assembly
please make sure you have a
suitable base ready to erect your
building



MADE IN GREAT BRITAIN

Overall Dimensions: Width = 4472mm
Depth = 4466mm
Height = 3538mm

Base Dimensions: Width = 4472mm
Depth = 4466mm

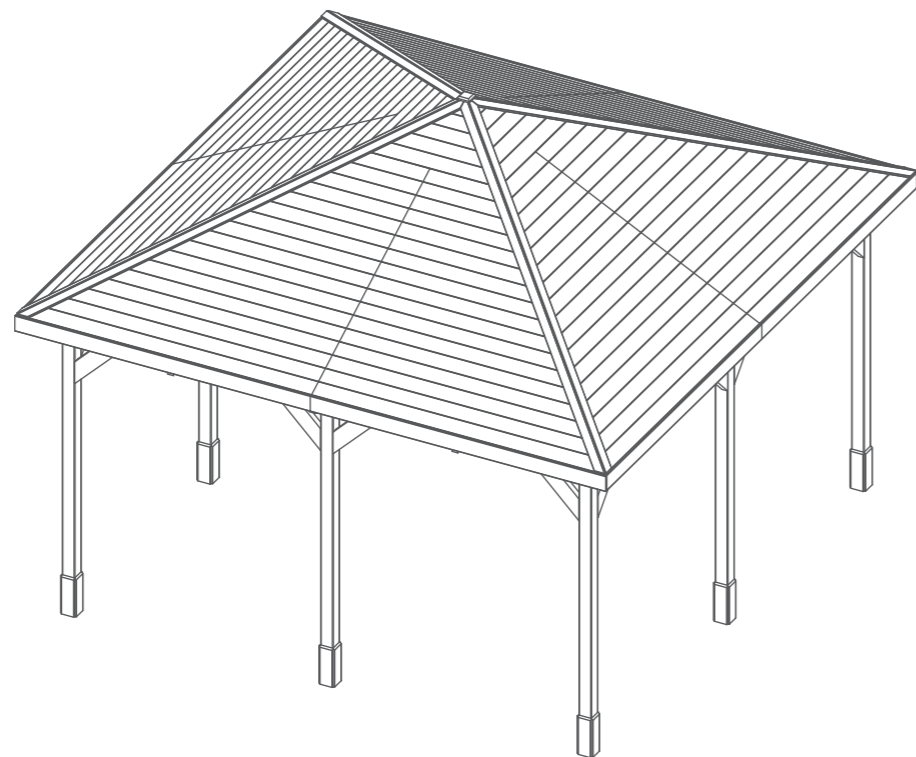

Contents:

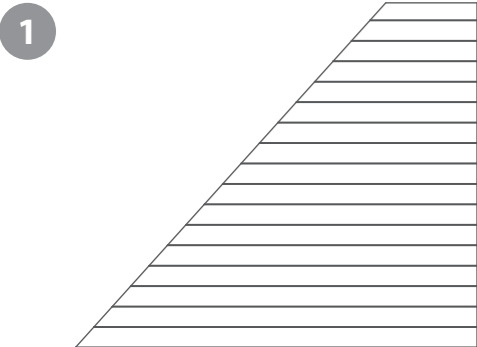

1
Roof Board Pack 1 QTY 8
AI-12MBHP4RBP1-V1

HINT: Keep the roof board packs separate to prevent mixing them up.

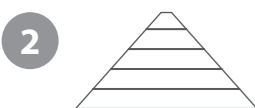

2
Roof Board Pack 2 QTY 4
AI-12MBHP4RBP2-V1

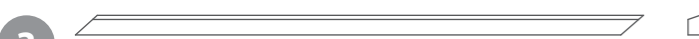

3
Top Truss Frame Left - 27x44x1612mm QTY 4
F2744-G-1612mm (1 x cut along profile, 2 x angled cuts left.)



4
Top Truss Frame Right - 27x44x1612mm QTY 4
F2744-G-1612mm (1 x cut along profile, 2 x angled cuts right.)

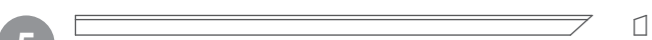

5
Bottom Truss Frame Left - 27x44x1575mm QTY 4
F2744-G-1575mm (1 x cut along profile, 1 x angled cuts left.)

6
Bottom Truss Frame Right - 27x44x1575mm QTY 4
F2744-G-1575mm (1 x cut along profile, 1 x angled cuts right.)



7
Cover Trim - 16x60x3310mm QTY 8
S1660-G-3310mm (2 x angled cuts.)



8
Fascia - 16x120x2400mm QTY 8
S16120-2400mm

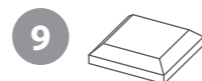

9
Cover Cap - 95x23x95mm QTY 1
ESDXL31FENGPC01BR



10
Roof Spacers QTY 8
PI-07-0208 (20x100x2mm)



11
Felt
(FELTED VERSION ONLY)

Nail Bag



50mm Screw x 98



30mm Screw x 816



Felt Tacks x 950

Pre-Assembly.

Before beginning construction of the Roof pack, please follow the instructions to fully construct the 4M x 4M Gazebo Frame (12PTGAZHP0404-V1).

Your Gazebo should look as shown.

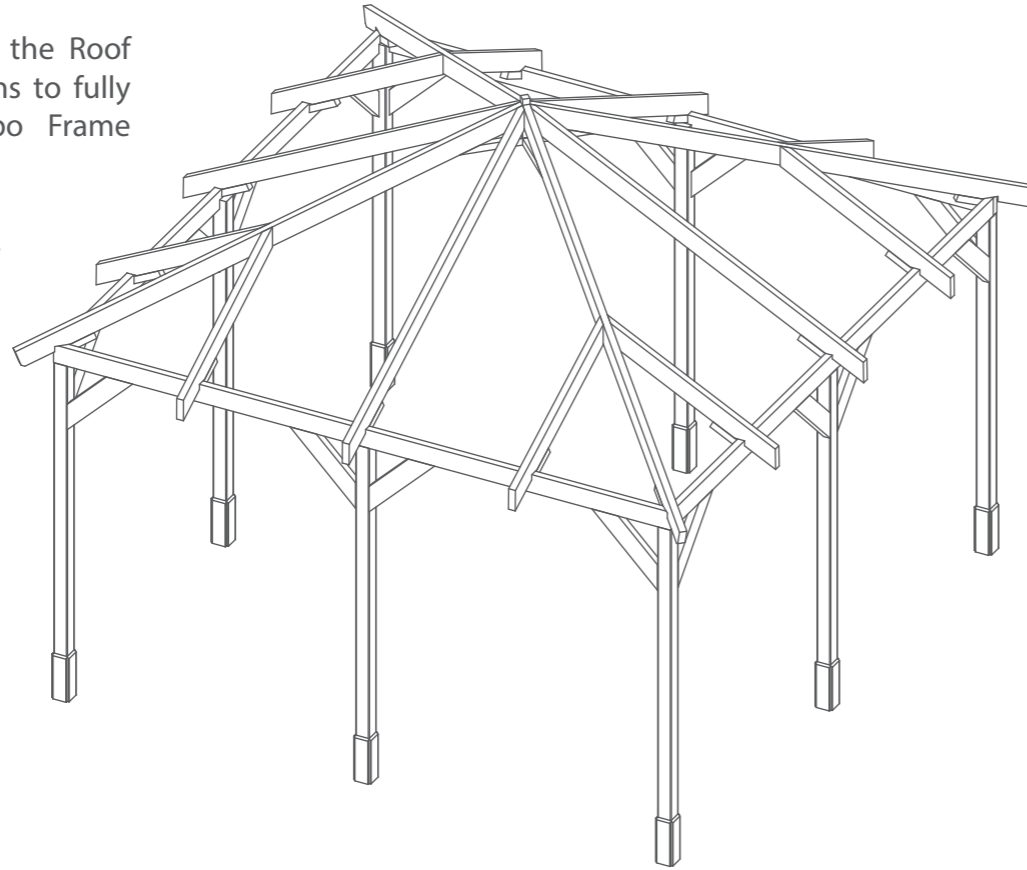

Step 1

Parts Needed - No. 3 QTY 1
No. 4 QTY 1

- a** On the top left side of one of the Corner Truss', position one Top Truss Frame Left (No.3) flush against the Truss.

Ensure the angled profile sits flush against the truss, the top of the truss is flush to the top edge of the framing and the angles fit correctly into the corners against the other truss', as shown.

Secure the framing in place using 4x50mm screws, going through the framing into the truss.

- b** On the opposite side of the Truss, use the same method to position one Top Truss Frame Right (No.4) flush against the truss.

Ensure the angled profile sits flush against the truss, the top of the truss is flush to the top edge of the framing and the angles fit correctly, as shown.

Secure the framing in place using 4x50mm screws, going through the framing into the truss.

Ensure to stagger screws to avoid collision.

8x50mm screws.

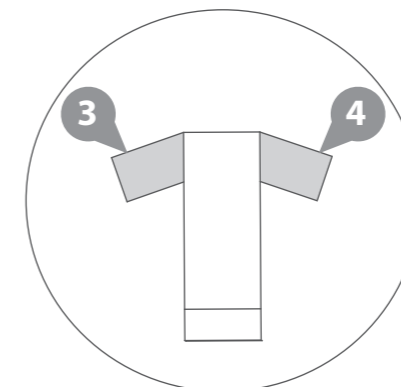
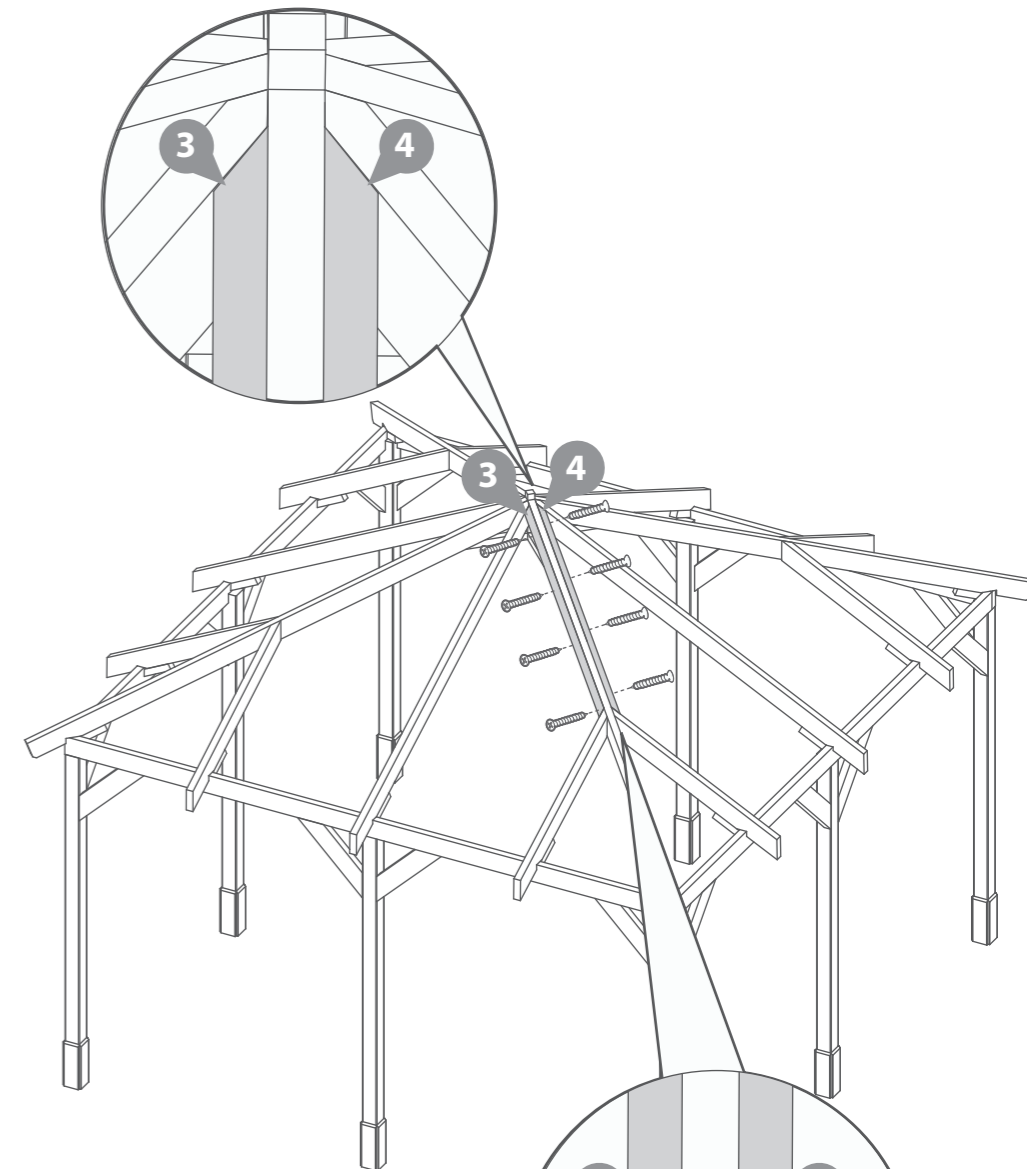
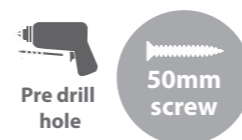

End view of Truss

IMPORTANT: Pre-drill before fixing screws.

Step 2

Parts Needed - No. 5 QTY 1
No. 6 QTY 1

- a** On the bottom left side of the same Corner Truss, position one Bottom Truss Frame Left (No.5) flush against the Truss.

Ensure the angled profile sits flush against the truss, the top of the truss is flush to the top edge of the framing, the angle fits correctly into the corner against the other truss' and the end is flush with the end of the truss, as shown.

Secure the framing in place using 3x50mm screws, going through the framing into the truss.

- b** On the opposite side of the Truss, use the same method to position one Bottom Truss Frame Right (No.6) flush against the truss.

Ensure the angled profile sits flush against the truss, the top of the truss is flush to the top edge of the framing and the ends sit correctly, as shown.

Secure the framing in place using 3x50mm screws, going through the framing into the truss.

Ensure to stagger screws to avoid collision.

6x50mm screws.

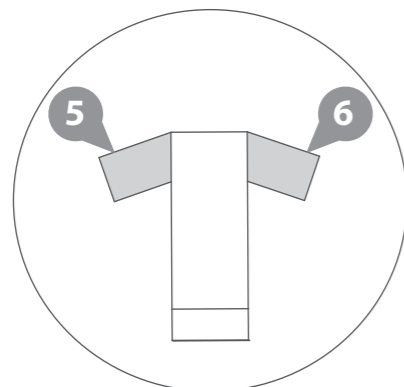
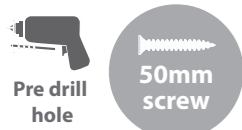

End view of Truss

IMPORTANT: Pre-drill before fixing screws.

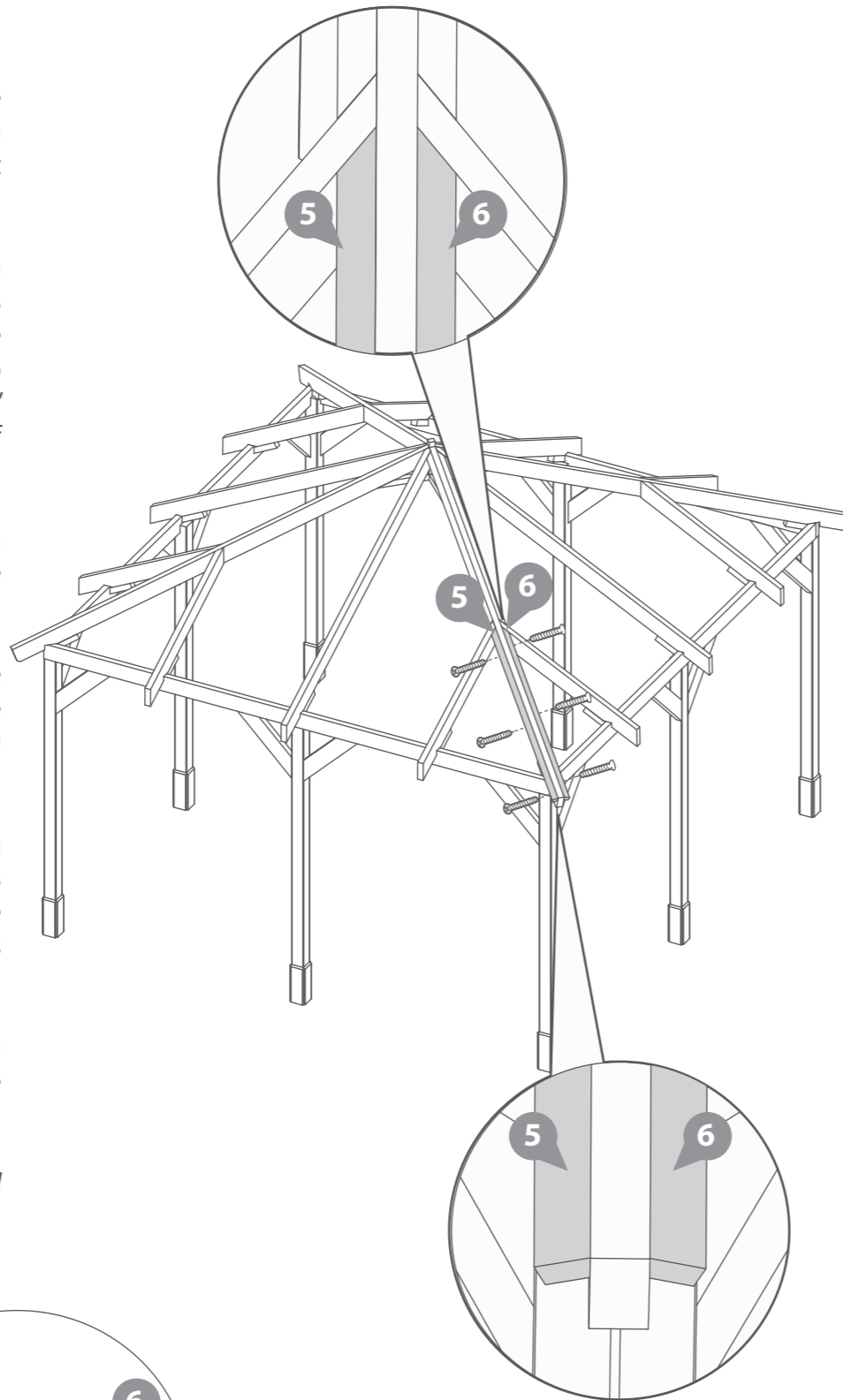

Step 3

Parts Needed - No. 3 QTY 3
No. 4 QTY 3
No. 5 QTY 3
No. 6 QTY 3

- a** Using the same methods as in Step 1 position and secure the remaining Top Truss Framing (No.3 & 4) on to each side of each corner Truss, as shown.

Ensure the angled profile sits flush against the truss, the top of the truss is flush to the top edge of the framing and the angles fit correctly into the corners against the other truss', as shown.

Secure the framing in place using 4x50mm screws per frame, going through the framing into the truss.

- b** Using the same methods as in Step 2 position and secure the remaining Bottom Truss Framing (No.5 & 6) on to each side of each corner Truss, as shown.

Ensure the angled profile sits flush against the truss, the top of the truss is flush to the top edge of the framing, the angle fits correctly into the corner against the other truss' and the end is flush with the end of the truss, as shown.

Secure the framing in place using 3x50mm screws per frame, going through the framing into the truss.

42x50mm screws.

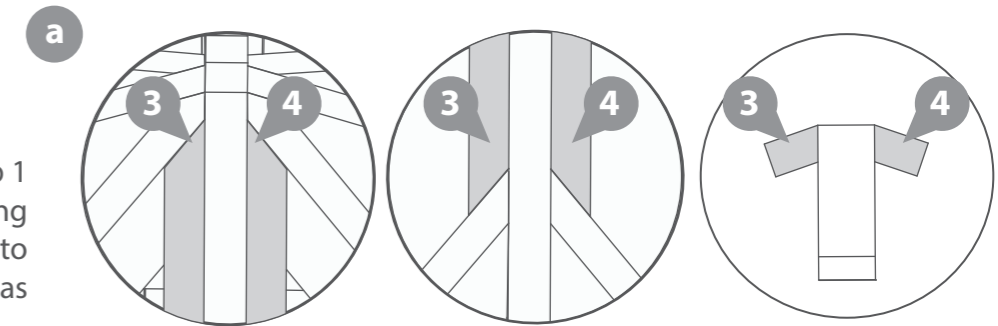

End view of Truss

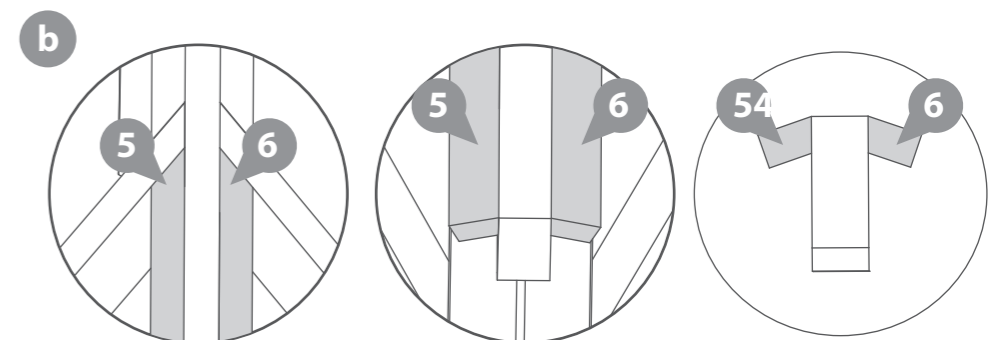
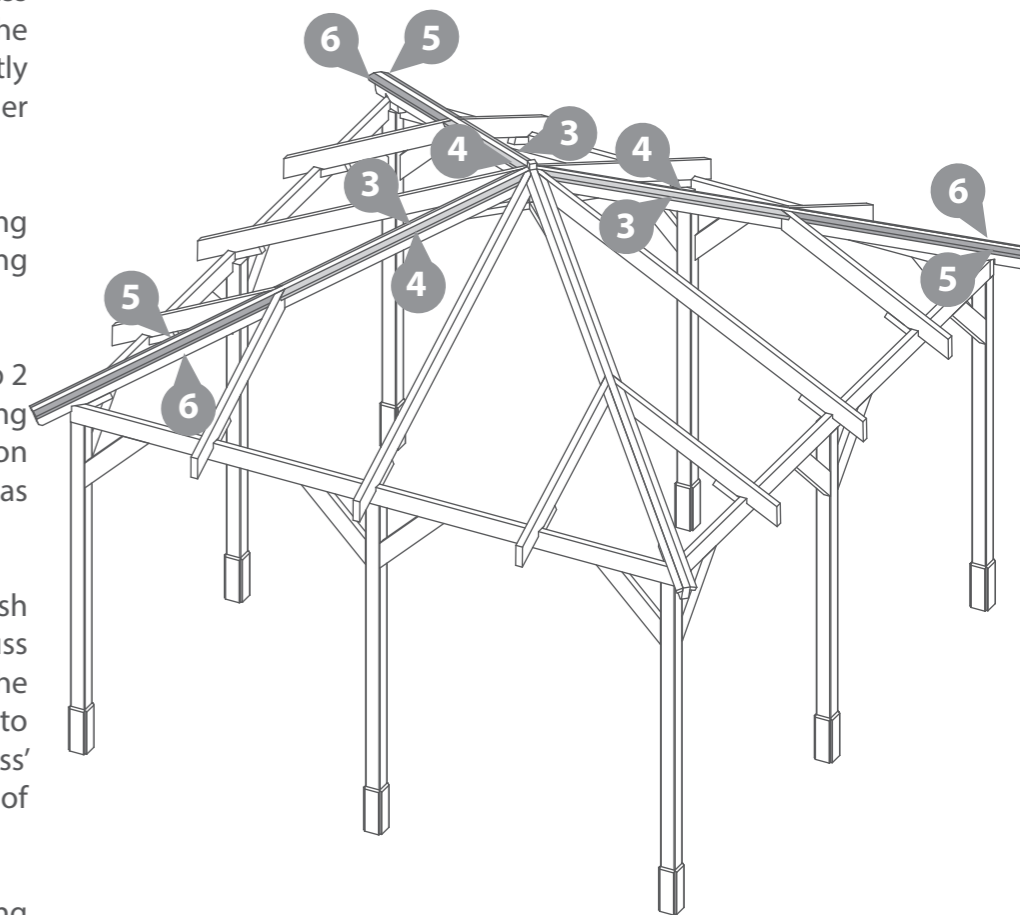

End view of Truss

Step 4

Parts Needed - No. 1 QTY 8

Place the first Roof Board from each 'Roof Board Pack 1' (No.1) onto the roof assembly, working around the gazebo.

Once you are happy with the fit of the roof boards, fix them in place using 6x30mm screws per board, fixing through the board into the truss or framing below.

48x30mm screws.



30mm screw

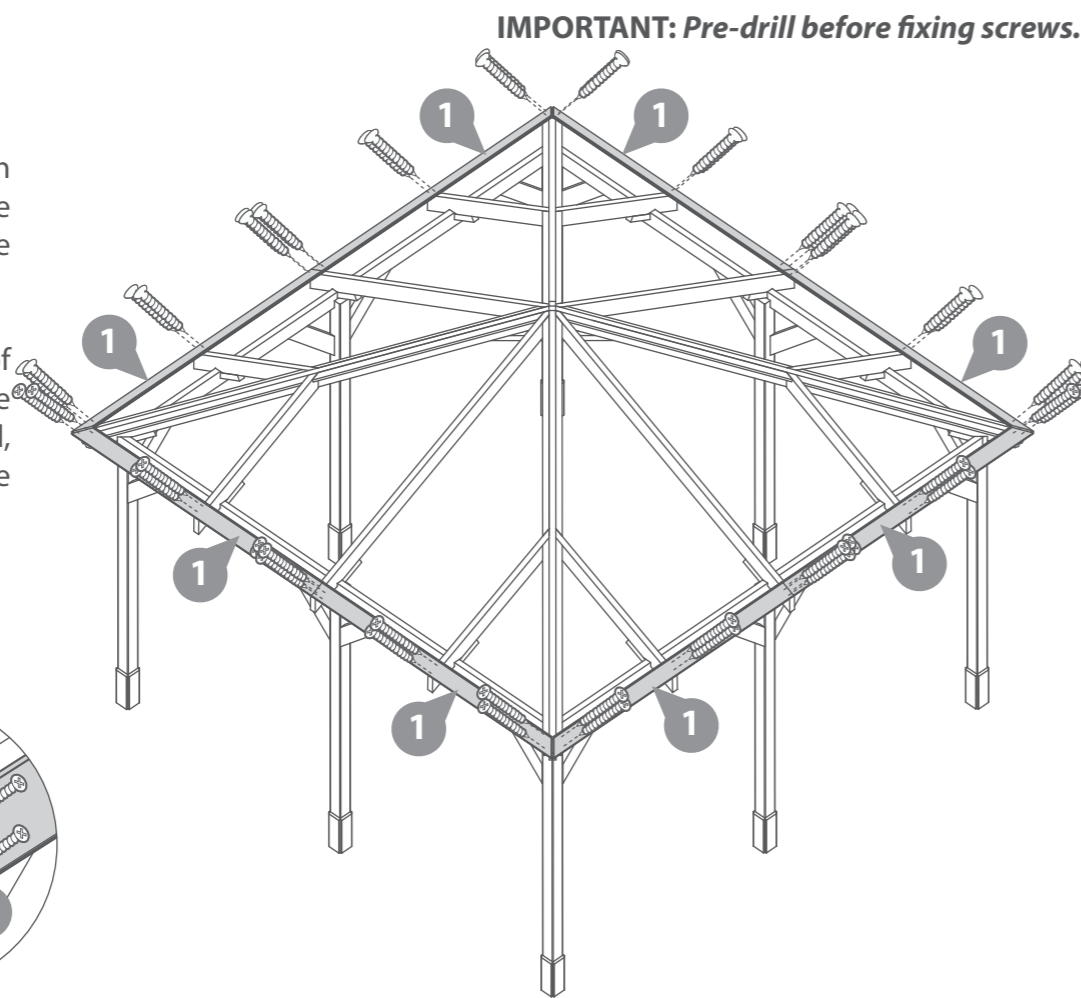
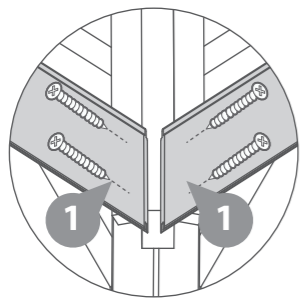

IMPORTANT: Pre-drill before fixing screws.

Step 5

Parts Needed - No. 1 QTY 8
No. 10 QTY 8

Continue to place the next 3 Roof Boards from each 'Roof Board Pack 1' (No.1) onto the roof assembly, working around the gazebo, building each layer of roof boards one by one.

To ensure the Roof boards are not laid too close together, use the Roof spacers (No.10) to create a 2mm gap between each board placed. Adjusting the spacing between the boards allows the wood to swell in damp weather.

Once you are happy with the fit of the roof boards, fix the 2nd, 3rd and 4th boards in place using 6x30mm screws per board, fixing through the board into the truss or framing below.

144x30mm screws.



Pre drill hole

30mm screw

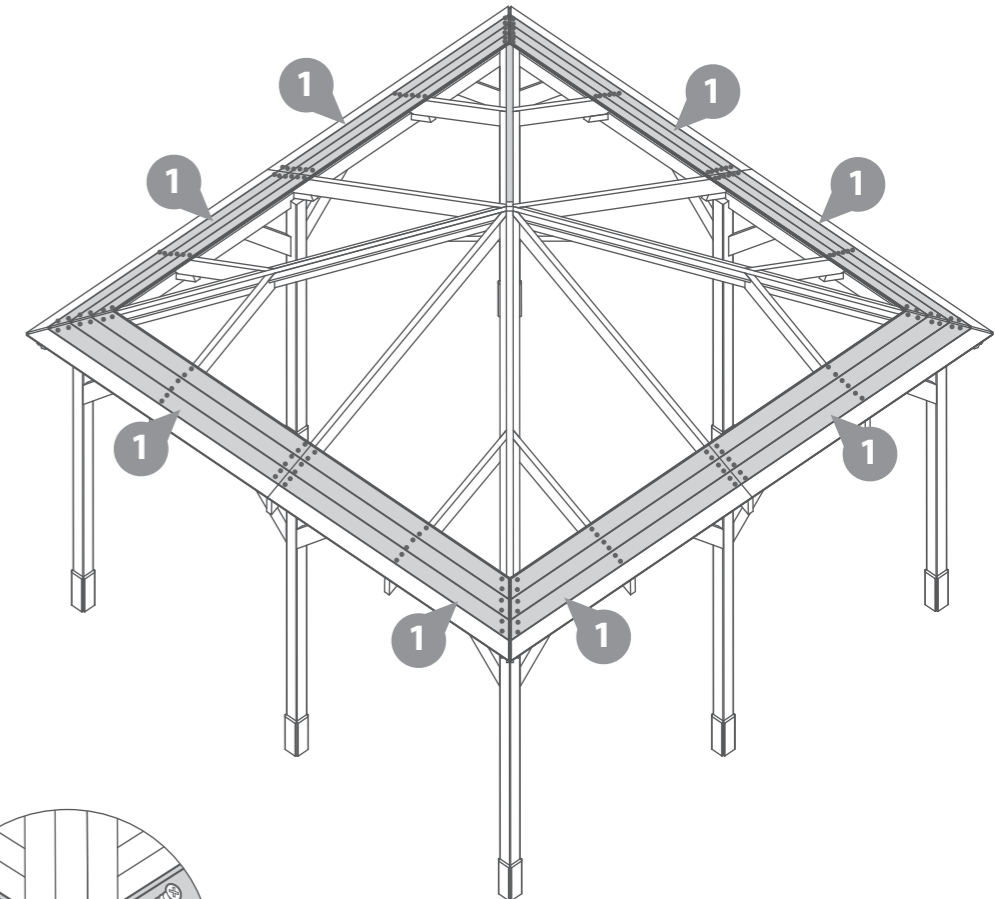
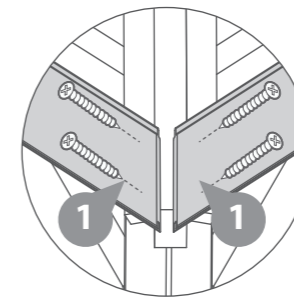

IMPORTANT: Pre-drill before fixing screws.

Step 6

Parts Needed - No. 1 QTY 8
No. 10 QTY 8

Continue to place the next 3 Roof Boards from each 'Roof Board Pack 1' (**No.1**) onto the roof assembly, working around the gazebo, building each layer of roof boards one by one.

To ensure the Roof boards are not laid too close together, use the Roof spacers (**No.10**) to create a 2mm gap between each board placed. Adjusting the spacing between the boards allows the wood to swell in damp weather.

Once you are happy with the fit of the roof boards, fix the 5th, 6th and 7th boards in place using 6x30mm screws per board, fixing through the board into the truss or framing below.

144x30mm screws.

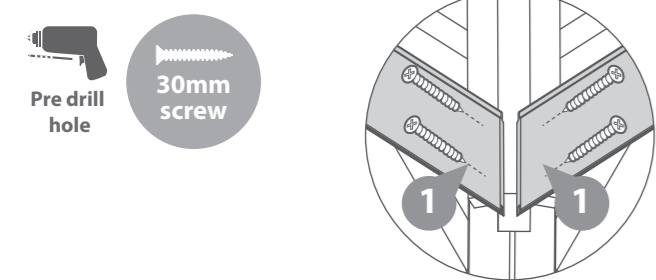

IMPORTANT: Pre-drill before fixing screws.

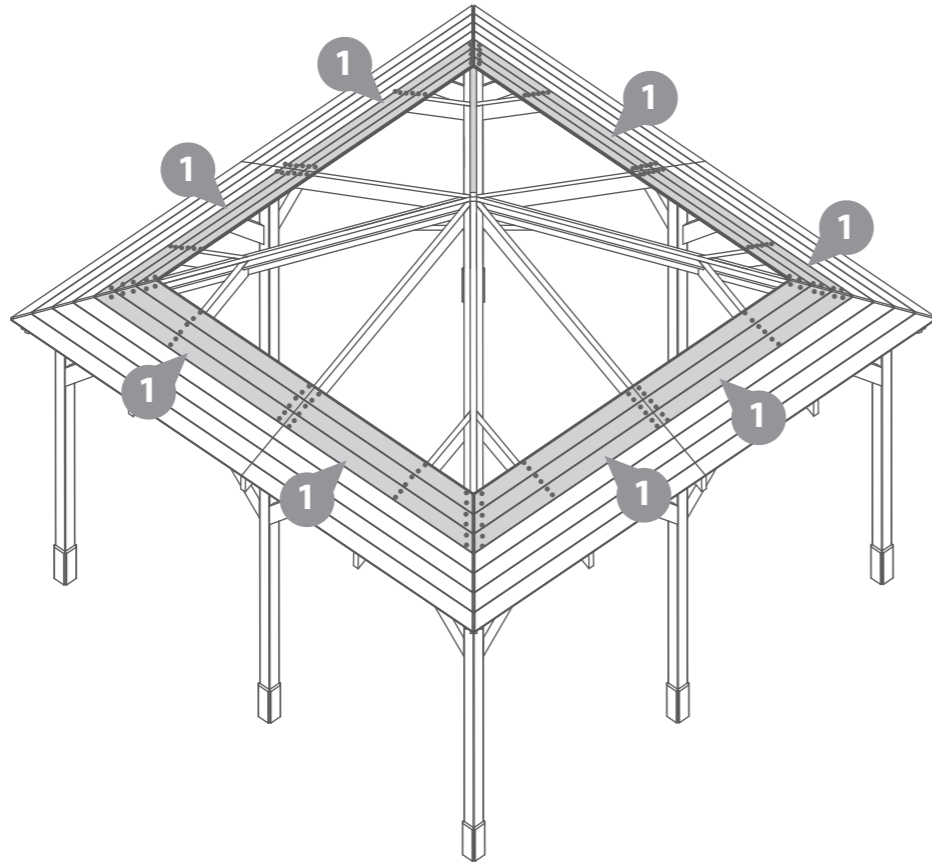

Step 7

Parts Needed - No. 1 QTY 8
No. 10 QTY 8

Continue to place the next 3 Roof Boards from each 'Roof Board Pack 1' (**No.1**) onto the roof assembly, working around the gazebo, building each layer of roof boards one by one.

To ensure the Roof boards are not laid too close together, use the Roof spacers (**No.10**) to create a 2mm gap between each board placed. Adjusting the spacing between the boards allows the wood to swell in damp weather.

Once you are happy with the fit of the roof boards, fix the 8th, 9th and 10th boards in place using 6x30mm screws per board, fixing through the board into the truss or framing below.

144x30mm screws.



IMPORTANT: Pre-drill before fixing screws.

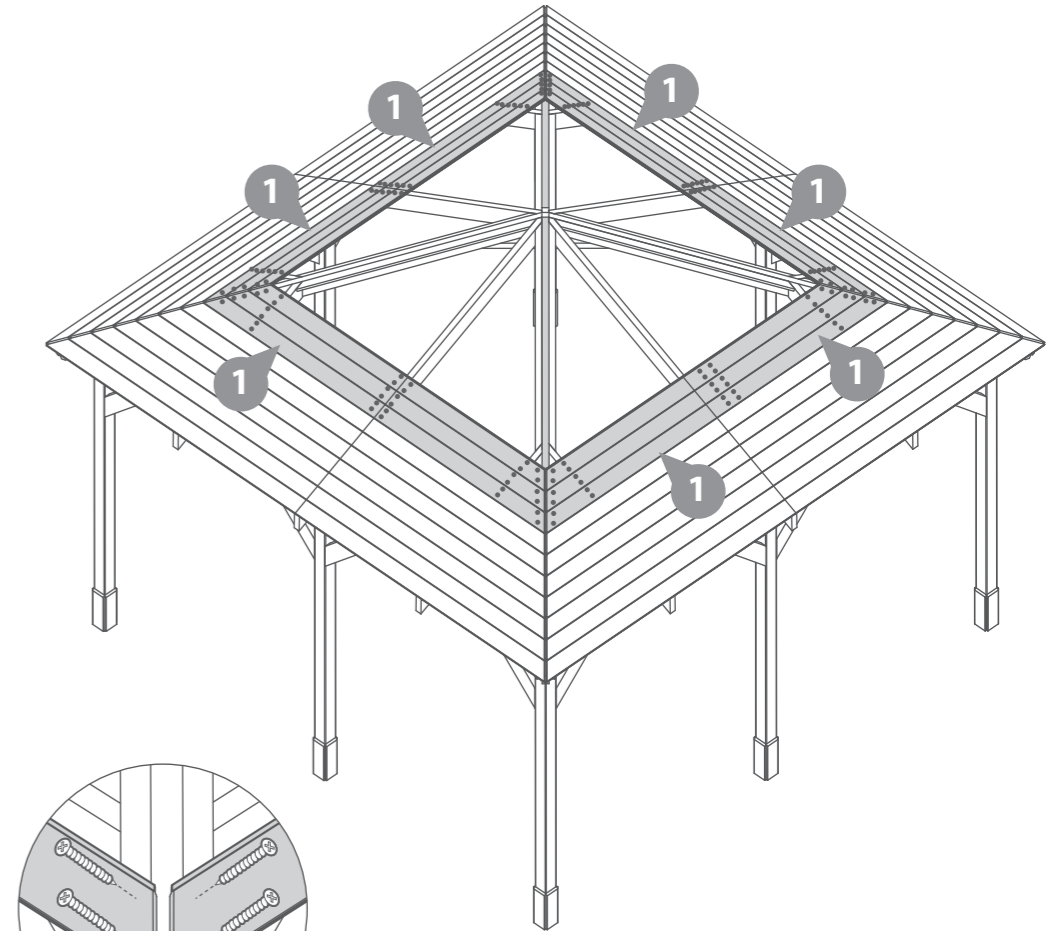

Step 8

Parts Needed - No. 1 QTY 8
No. 10 QTY 8

Continue to place the next 3 Roof Boards from each 'Roof Board Pack' (No.1) onto the roof assembly, working around the gazebo, building each layer of roof boards one by one.

To ensure the Roof boards are not laid too close together, use the Roof spacers (No.10) to create a 2mm gap between each board placed. Adjusting the spacing between the boards allows the wood to swell in damp weather.

Once you are happy with the fit of the roof boards, fix the 11th boards in place using 6x30mm screws per board.

Fix the 12th and 13th boards in place using 4x30mm screws per board, fixing through the board into the truss or framing below.

112x30mm screws.

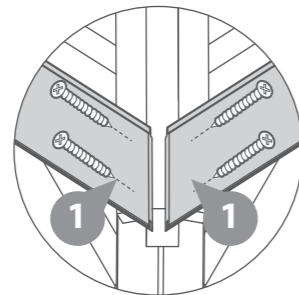
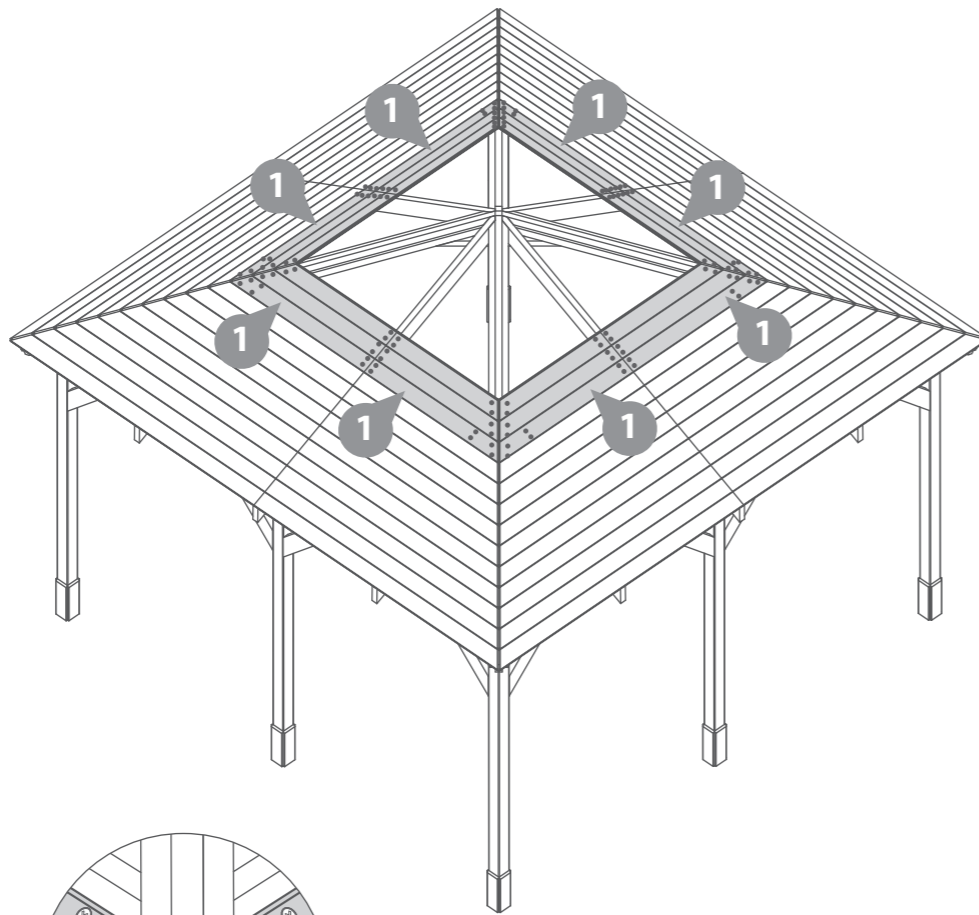
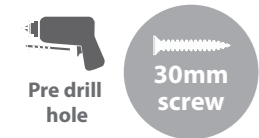

IMPORTANT: Pre-drill before fixing screws.

Step 9

Parts Needed - No. 1 QTY 8
No. 10 QTY 8

Place the remaining four Roof Boards from each 'Roof Board Pack 1' (No.1) onto the roof assembly, working around the gazebo, building each layer of roof boards one by one.

To ensure the Roof boards are not laid too close together, use the Roof spacers (No.10) to create a 2mm gap between each board placed. Adjusting the spacing between the boards allows the wood to swell in damp weather.

Once you are happy with the fit of the roof boards, fix the 14th, 15th, 16th and 17th boards in place using 4x30mm screws per board, fixing through the board into the truss or framing below.

96x30mm screws.

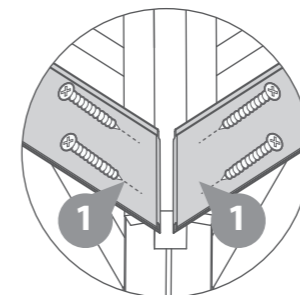
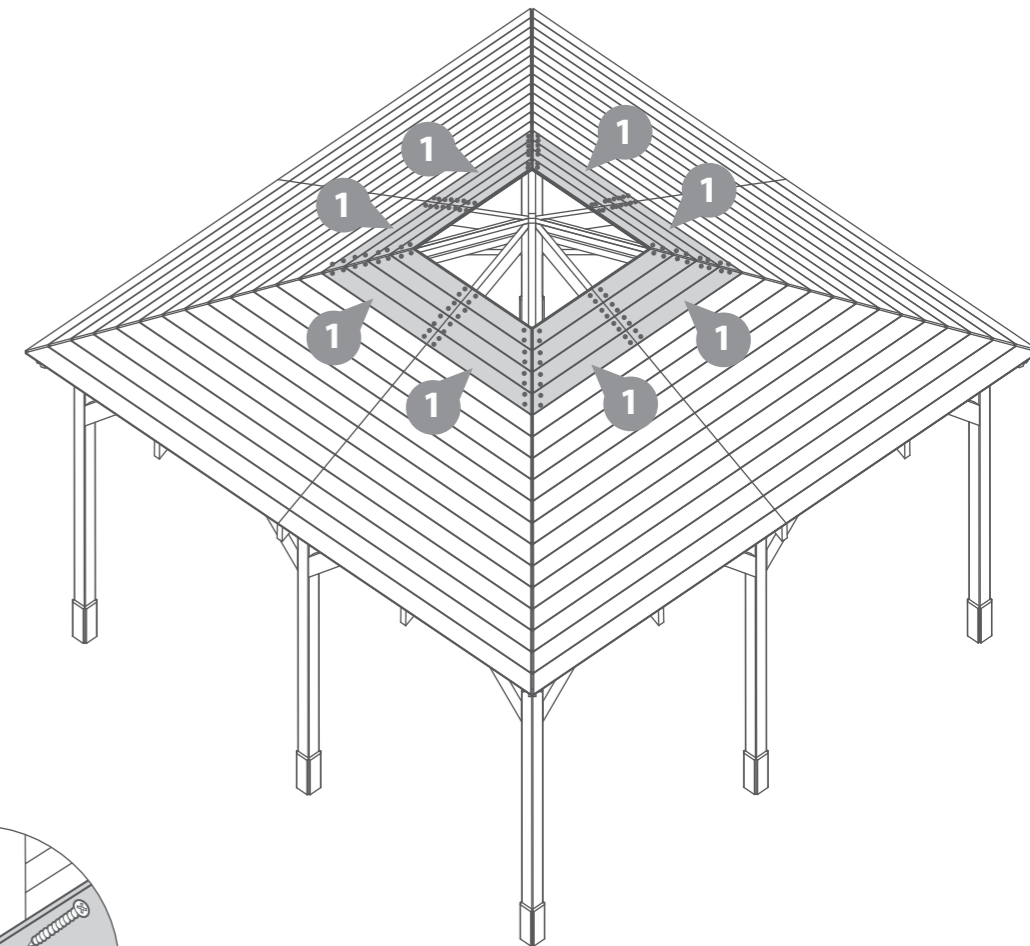
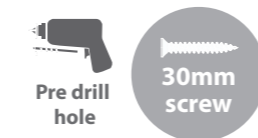

IMPORTANT: Pre-drill before fixing screws.

Step 10

Parts Needed - No. 2 QTY 4
No. 10 QTY 4

Place the first three Roof Boards from each 'Roof Board Pack 2' (No.2) onto the roof assembly, working around the gazebo, building each layer of roof boards one by one.

To ensure the Roof boards are not laid too close together, use the Roof spacers (No.10) to create a 2mm gap between each board placed. Adjusting the spacing between the boards allows the wood to swell in damp weather.

Once you are happy with the fit of the roof boards, fix in place using 6x30mm screws per board, fixing through the board into the truss or framing below.

72x30mm screws.

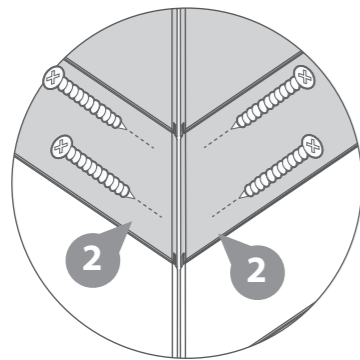
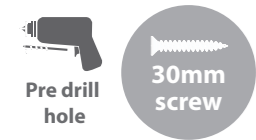

IMPORTANT: Pre-drill before fixing screws.

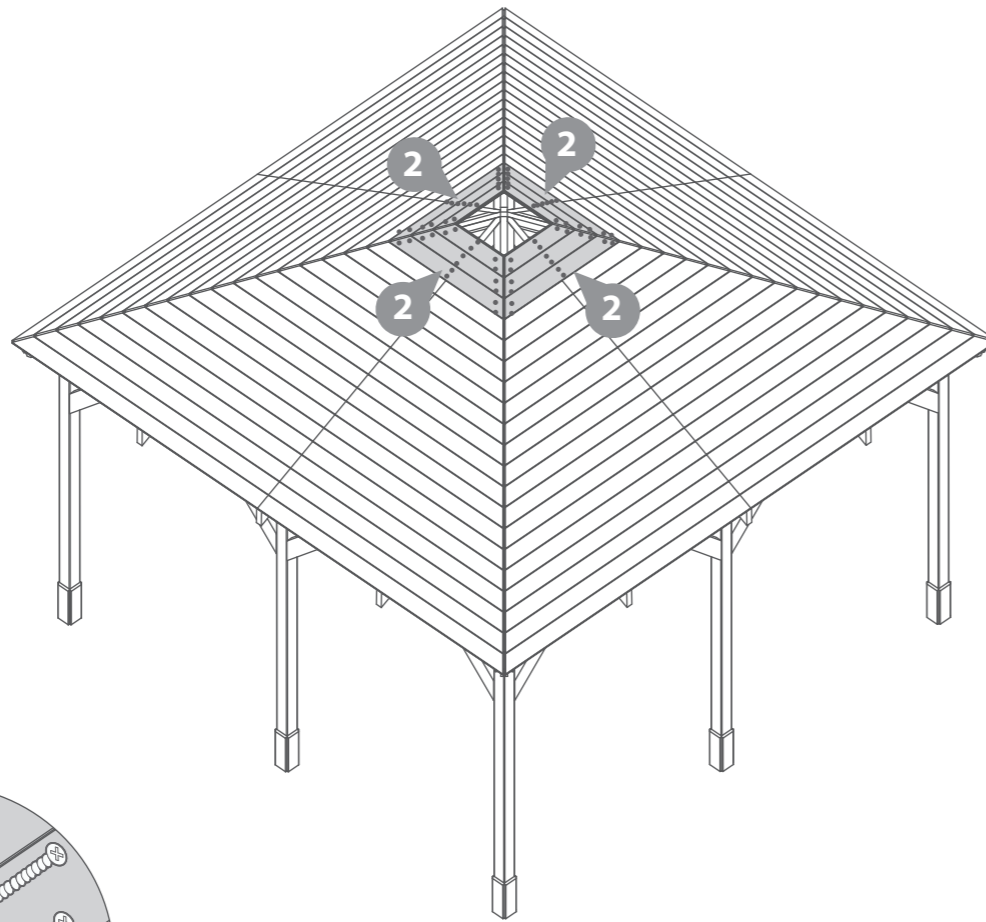

Step 11

Parts Needed - No. 2 QTY 4
No. 10 QTY 4

Place the remaining four Roof Boards from each 'Roof Board Pack 2' (No.2) onto the roof assembly, working around the gazebo, building each layer of roof boards one by one.

To ensure the Roof boards are not laid too close together, use the Roof spacers (No.10) to create a 2mm gap between each board placed. Adjusting the spacing between the boards allows the wood to swell in damp weather.

The last board on each side may dig into the central roof block.

Using a pencil and a straight edge, mark out the area that will dig in. Cut long the marked out line, remove the excess and place the board back onto the roof.

Once you are happy with the fit of the roof boards, fix in place using 2x30mm screws per board, fixing through the board into the truss or framing below.

16x30mm screws.

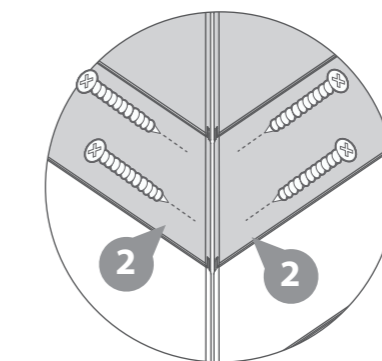
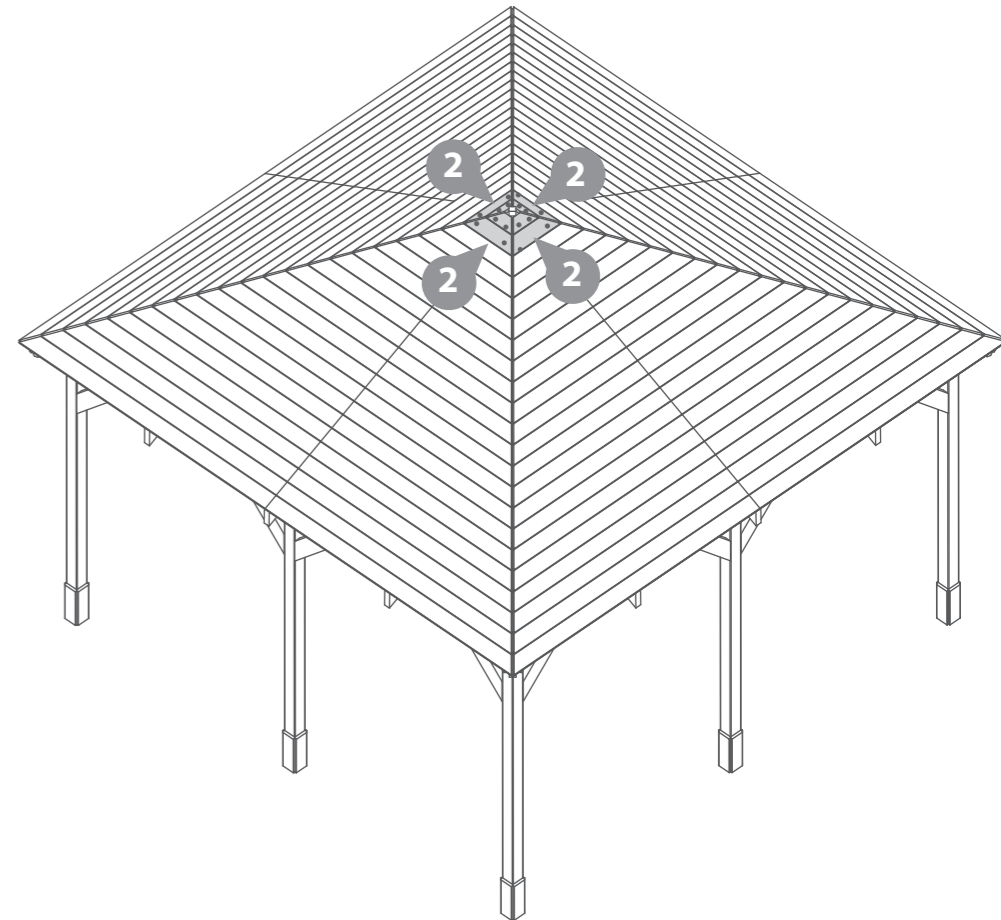
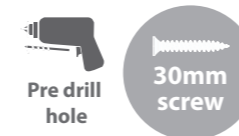

IMPORTANT: Pre-drill before fixing screws.

FELTED VERSION ONLY

If you have not purchased the felted version please skip this step and continue onto step 13.

Step 12A

Parts Needed - No. 11

Measure and cut the Felt (No.11) using the dimensions below:

- A. 4500mm (L) x 1000mm (W) QTY 4
- B. 3500mm (L) x 1000mm (W) QTY 4
- C. 1350mm (L) x 1000mm (W) QTY 4

Lay the first sheet (1-A = 4500mm x 1000mm) onto the roof as shown (1-A) and cut down to the individual shape of the roof.

Continue this method to lay each sheet of felt in the order show (2-A, 3-A, 4-A, 5-B etc).

Ensure each sheet overlaps the next by 50mm and that there is 50mm overhang around the edge of the gazebo.

Secure along the outer edge of each section using felt tacks spaced at 100mm intervals.

650 x Felt Tacks.

Aerial view of roof assembly

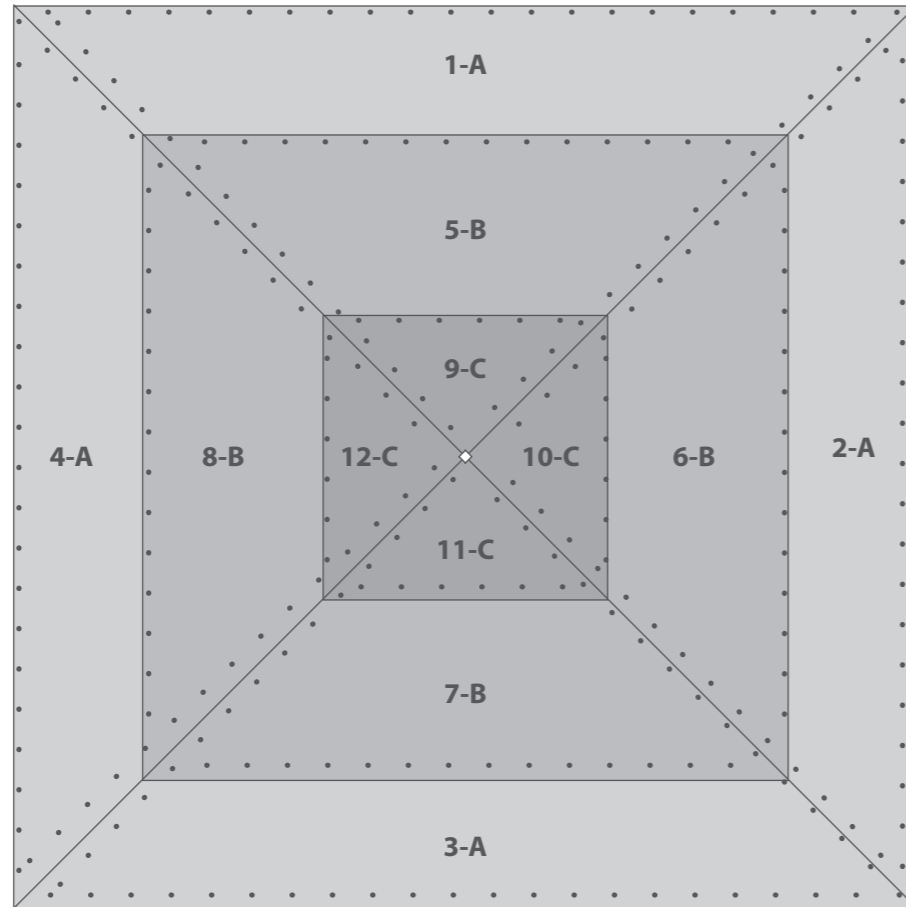

FELTED VERSION ONLY

If you have not purchased the felted version please skip this step and continue onto step 13.

Step 12B

Parts Needed - No. 11

Measure and cut the Felt (No.11) using the dimensions below:

- 3300mm (L) x 200mm (W) QTY 4

Lay the strips onto the roof in the order shown.

Secure each strip in place using felt tacks at 100mm intervals.

300 x Felt Tacks.

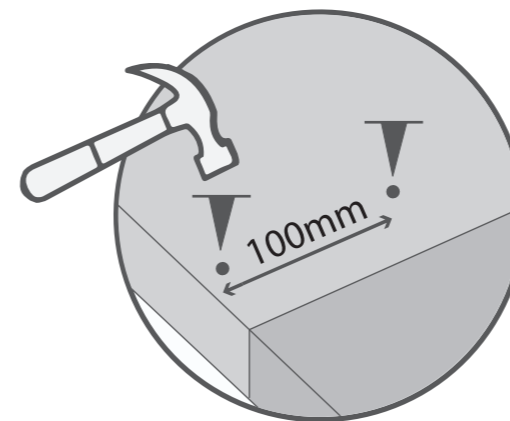

Aerial view of roof assembly

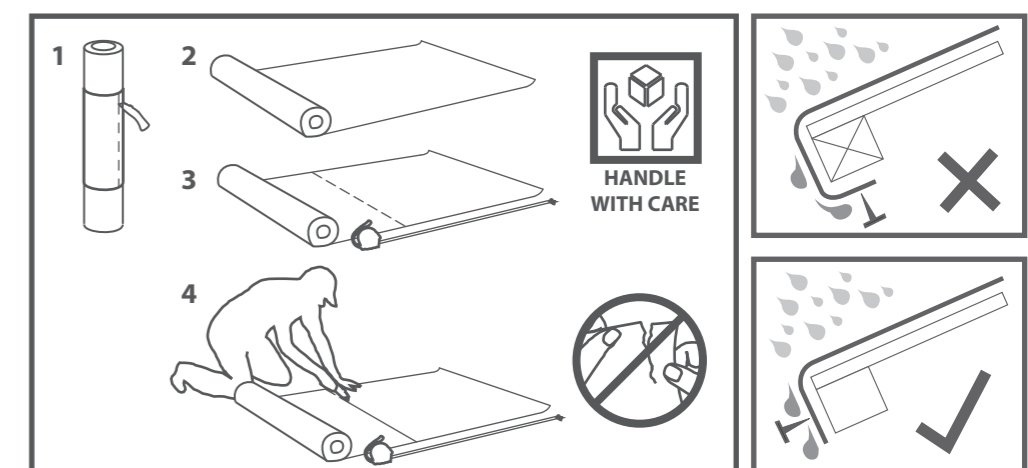
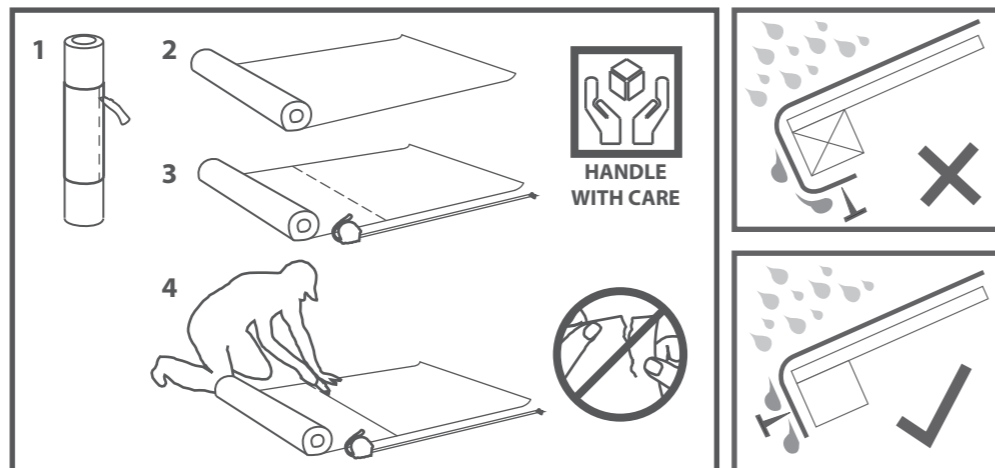
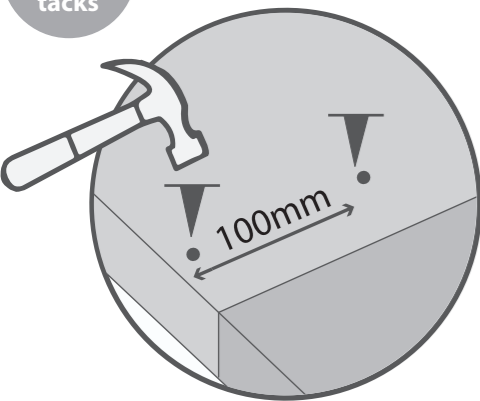
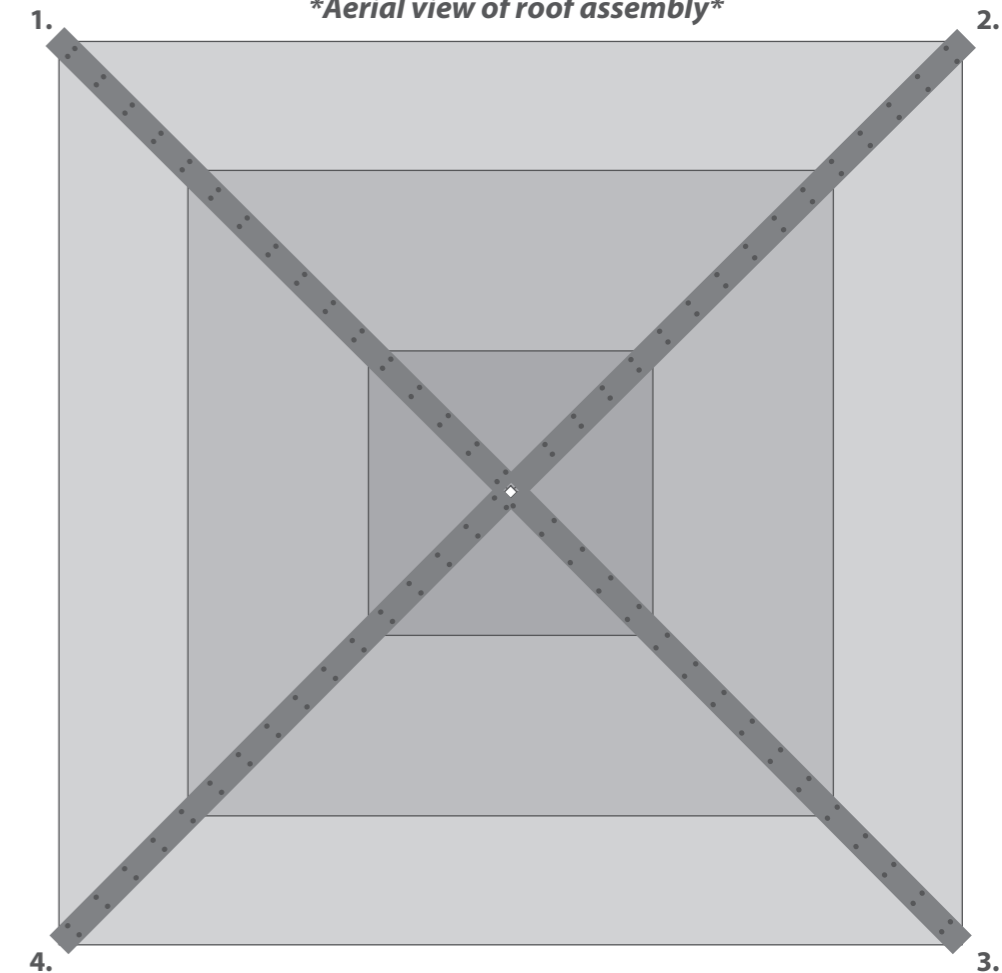

Step 13

Parts Needed - No. 7 QTY 8

Position the Cover Trims (No.7) onto one corner edge of the roof, as shown.

Ensure the edges of the Trims are together and line up with the corner edge of the roof.

Make sure the angled ends are aligned and flush with the outside edges of the Roof Boards.

Secure in place by screwing through the trim into the roof boards below using 5x30mm screws per trim.

Repeat this method to secure trims to each corner edge.

40x30mm screws.

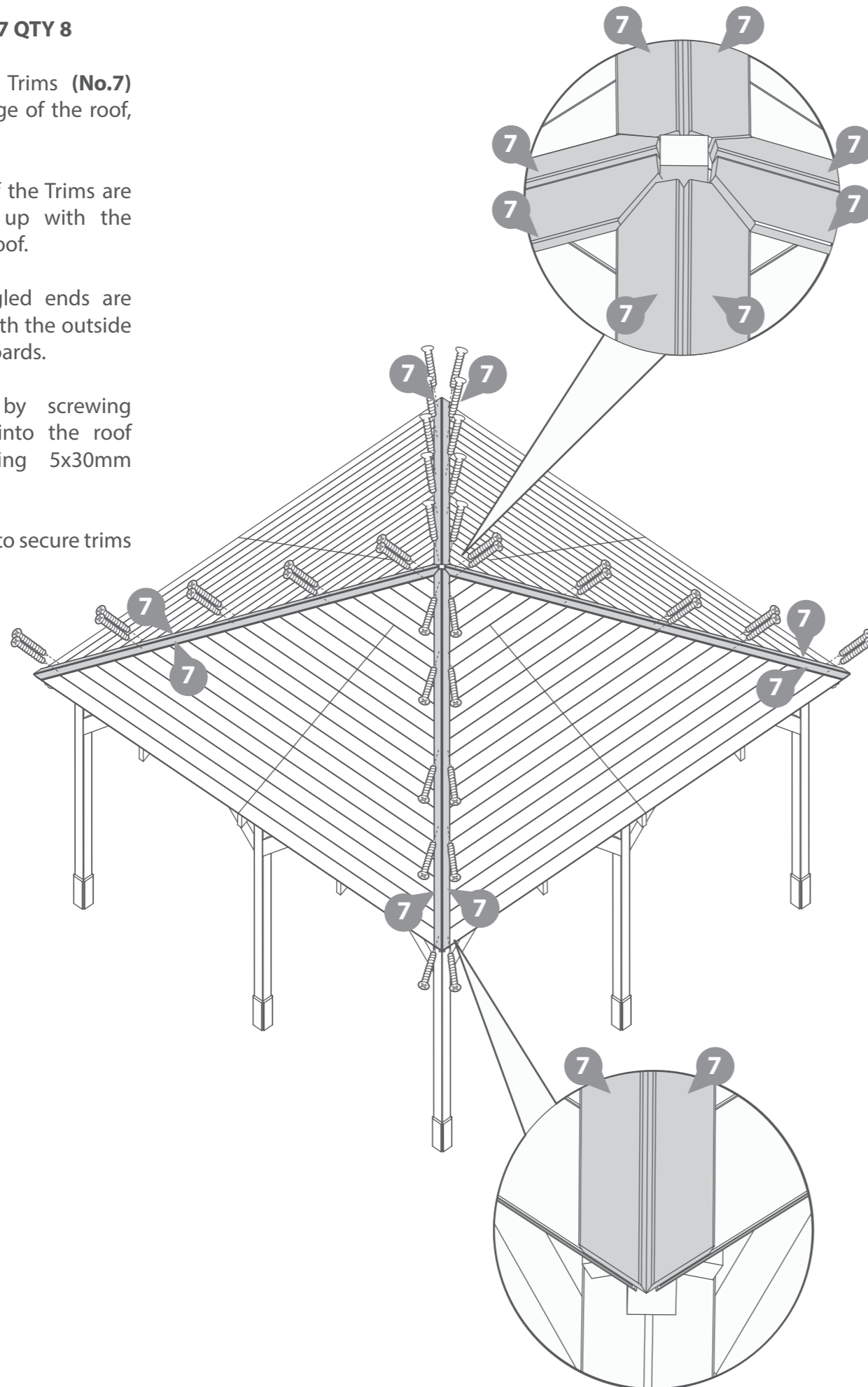
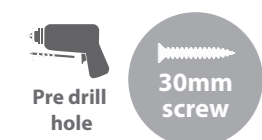

IMPORTANT: Pre-drill before fixing screws.

Step 14

Parts Needed - No. 8 QTY 8

a Measure the width of the Gazebo (from Roof Board corner to corner) and cut two Fascias (No.8) down to this total size.

Locate the two cut Fascias (No.8) onto opposite sides of the Gazebo and fix in place using 4x50mm screws per Fascia, screwing through the fascias in to the Truss' behind.

Ensure the Fascias are flush and level to each other and line up with the top edge of the Roof Boards.

b Measure the distance between the secured Fascias (No.8) and cut the remaining two Fascias (No.8) to these total sizes.

Locate the remaining Fascias between the already secured Fascias and secure them to each truss using 4x50mm screws per fascias.

Fix the Fascias together to the ends using 2x50mm screws per end. Ensure to screw through one Fascias into the other.

If you have purchased the felted version, ensure to trap the felt between the roof boards and the fascias before fixing in place.

40x50mm screws.

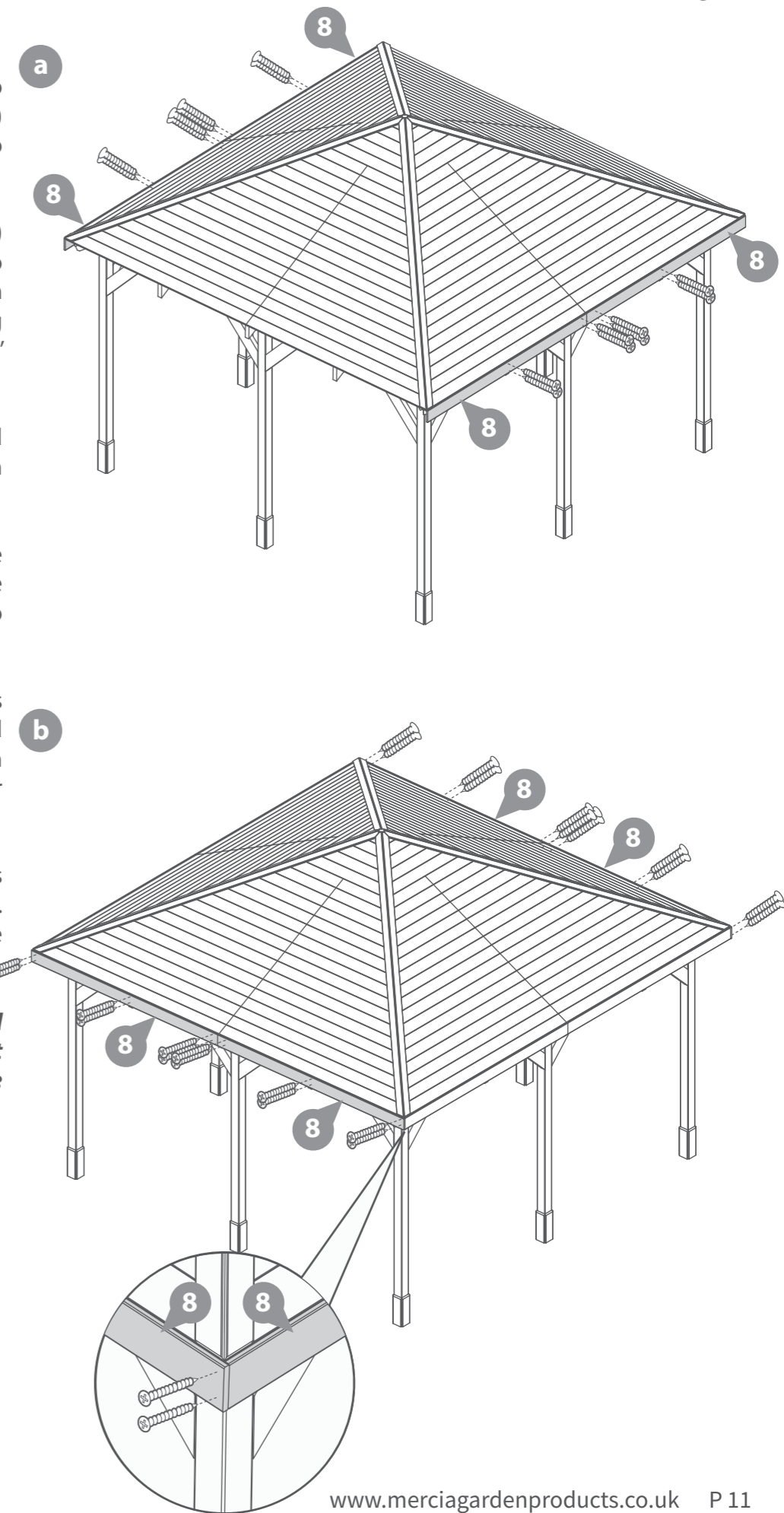

IMPORTANT: Pre-drill before fixing screws.

Step 15

Parts Needed - No. 9 QTY 1

Position the Cover Cap (No.9) centrally on top of the central roof block.

Secure in place using 2x50mm screws, going down through the cap into the block below.

2x50mm screws.

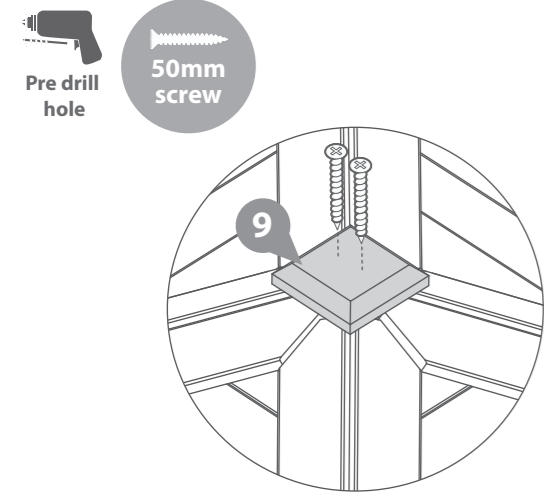

IMPORTANT: Pre-drill before fixing screws.

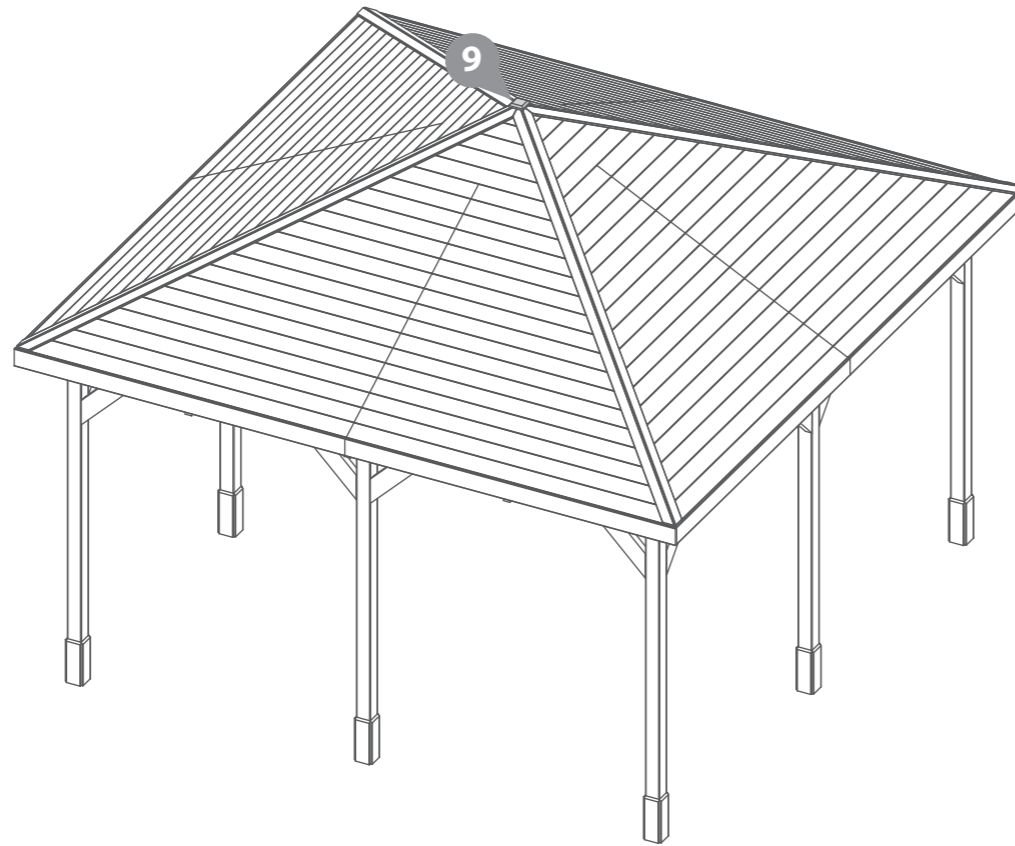

TREATING YOUR GARDEN PRODUCT

Preservation of wood that's outdoors is vital. A little early care will help protect your garden product, improve its appearance and ensure maximum longevity. Insects, moisture, salt, and changing weather can have dramatic effects on the stability and appearance of your garden product. Once your product is installed, you've checked it over and you're happy with it, you can take a few basic precautions to prepare it for the elements. Treating your garden product helps prevent decay and, by repelling water, discourages the growth of moulds and fungi that could jeopardise the structural integrity of the wood.

Dip Treated products - Require a preservative treatment to protect against rot and decay and a waterproof treatment to prevent water ingress
Pressure Treated products - Require a waterproof treatment to prevent water ingress
Log Cabins/Insulated Garden Rooms - Are supplied untreated and require a preservative and waterproofing treatment.



ANY QUESTIONS?
CONTACT US ON
01636 821215

To apply a preservative and water proofing treatment (pressure treated products do not require a preserver), follow the manufacturer's instructions but in principle, stick to the following steps:

- ✓ Wear latex or rubber gloves, eye protection and (if spraying) a mask.
- ✓ Prepare the wood, by sanding down any ridges or inconsistencies in the wood, smoothing out knots and end-cuts.
- ✓ Choose a dry day to treat your garden product. If you're spraying rather than brushing paint on, avoid a windy day.
- ✓ Be sure you can safely reach all the sections you need to paint - and if you need a ladder, make sure it's safely positioned before climbing. Lay dust sheets around to avoid paint splatters on your base or surrounding plants.
- ✓ Tape around windowpanes to avoid smears when you're painting the frames.
- ✓ Keep pets and small children out of the way. The last thing you want is to have fur on your garden product paint, or little painted footprints all over your garden and home.
- ✓ Fill any gaps in the product body with caulk or wood filler to prevent water and draughts getting in. Silicone based caulk is flexible and will move with the timber when temperature and humidity change. Allow to dry completely before treating. A handy tip for finding gaps is to go into your garden building and look for light leaking through joins and frames. If light gets in, then so will water.
- ✓ Liberally apply at least two coats of the treatment products with a brush or spray, taking care to allow the first coat to completely dry before applying the second.
- ✓ Make sure the solution permeates the whole of the surface area, especially around natural cracks, end cuts and nail/screw holes.



APPLY WOOD TREATMENT
IMMEDIATELY
AFTER ASSEMBLY

PLEASE SCAN HERE TO
SEE TREATMENT VIDEO:



1 Perimeter

Check around the perimeter of your product to ensure there are not trees or plants that are in contact with or overhanging the product. This can affect airflow and overhanging trees, or branches can damage the roof, it is advised to keep plants at a distance.

2 Repair

Inspect the interior and exterior of the product to look for splits, cracks, and holes. Although this is a natural occurrence it can be prevented. A wood filler can be used to close the splits, cracks, and holes.

3 Roof

Check your roof regularly for tears, splits, damaged wood and fallen debris. If you notice any of this immediate repair is critical.

4 Doors & Windows

Expansion and contraction can cause doors and windows to stick or become difficult to open. Small adjustments to the hinge position can be made to the doors and windows to allow free movement.

5 Oil

Hinges can seize up over time, apply lubricant to the hinges and locks annually.

6 Screws & Bolts

It is advised to check all screws and bolts and tighten any loose you might find. For log cabins specifically the storm braces will require loosening. During humidity and temperature changes (seasons) to allow expansion and contraction to prevent gaping, twisting, popping, and warping.

7 Wash

At least once a year, give the outside of your product a good wash, to remove cobwebs, leaves, or any other dirt that may accumulate on the exterior.

8 Airing

Airing your product regularly prevents the build up of condensation which can cause the timber to warp, bow, boards to pop, distortion, rot and mould. Condensation can build up over time or daily, it is caused by a rise and fall in temperature.

Excessive moisture levels within your building can cause water to collect on the roofs, walls and floors internally. Leaving doors and windows open regularly can help combat the natural moisture build up.

9 Clean & Tidy

It is good practice to clean the inside and outside of your product regularly. Clear out the contents, sweep the floor, remove dirt and cobwebs. Check for areas of damp and investigate the cause to remove and prevent future occurrences. Check the ground around your product for build up of debris such as leaves, remove and ensure there is clear ventilation underneath the floor.

Additional Playhouse Maintenance:

It is recommended that the following checks and maintenance are carried out at the beginning of each season as well as at regular intervals during the usage season.

- Check all nuts /bolts/ screws for tightness and tighten when required.
- Check for movement / opening of wood giving rise to protrusion of nail heads and tips.
- Check hinges.
- Replace defective parts in accordance with the manufacturers instructions.
- Check any crossbeams, suspensions and anchors.
- If a swing is included; check the swing seat, chains and ropes.

IF THESE CHECKS ARE NOT CARRIED OUT THE ACTIVITY TOY COULD BECOME A HAZARD

All our garden product have been designed and manufactured with care and attention to be the perfect addition to your outdoor space. To ensure you do get the best out of your new garden product and to increase the longevity we advise that you follow the product instructions and our manufacturer's recommendations as detailed below. Thank you for choosing a Mercia Garden product!

1 Choosing the most suitable location for your garden product...

A minimum of 60cm should be left around the perimeter of your garden product to allow access for maintenance, annual treatment and to allow air flow around the product.

Where possible you should avoid placing your garden product underneath large trees to prevent the tree causing damage to the product.

2 Preparing the base for your garden product...

All our products must be built on a firm, level base to ensure the longevity of the product and prevent the wood from distorting. We recommend either concrete, concrete slabs or a wooden base, such as our 'Portabase' for buildings.

The base should be slightly smaller than the external measurement of the building, i.e. the cladding should overlap the base, creating a run off for water and preventing water from pooling underneath the building.

We also recommend that the floor of the garden building is a minimum of 25mm above the surrounding ground level to avoid flooding.

3 After installation...

Once your garden product has been installed, it will need to be treated within 14 days (weather permitting) and annually to prevent the timber from deteriorating and to waterproof it. This is required to maintain the anti-rot guarantee.

Dip Treated products - Require a preservative treatment to protect against rot and decay and a waterproof treatment to prevent water ingress.

Pressure Treated products - Require a waterproof treatment to prevent water ingress.

Log Cabins/Insulated Garden Rooms - Are supplied untreated and require a preservative and waterproofing treatment.

We also recommend using a silicon sealant on the inside and outside of the windows as soon as possible after assembly and treatment to fully seal the windows.

Roofing felt/covering should be checked annually and replaced or fixed accordingly.

4 General maintenance and wood characteristics

As wood is a natural material it may be affected by the following:

Shrinkage and warping - The timber used in the construction of your garden product will have retained some of its natural moisture content. The moisture content of the timber will vary, depending upon prevailing environmental conditions, which will result in the components either naturally expanding or contracting. As the components dry out, shrinkage may occur. A good waterproofing treatment from the start is the best protection to minimise the effect of moisture loss/intake.

In extended periods of very warm weather getting some moisture to the product will help the overall balance. You can do this by spraying it down lightly with a garden hose. In contrast, after snow fall try to remove the snow as best as possible from the roof to prevent moisture intake and to remove the extra weight.

Top tip - using a garden brush will help you to reach the highest part of the product to remove snow and any debris left from bad weather.

Damp and mould - During the winter months, cold and damp conditions can result in an increased amount of moisture within your garden product, especially when used infrequently. Condensation can form on the timber and other items stored within your garden building. If left this moisture is likely to cause mould and mildew.

To prevent the build-up of moisture, we recommend leaving the door or windows of your building open from time to time, to allow the fresh air to circulate. We also advise against storing wet or damp items in your garden building as this will also increase the level of moisture in the building. If mould or mildew does start to form within your building we recommend using an anti-mould cleaner to remove it and to prevent it spreading, which if left untreated could permanently damage your garden building.

Splits, cracks and knots - You may notice small splits and cracks in some components or holes may appear where knots shrink and fall out. This will not affect the structure of your Garden product however, if you wish to fill them this can be easily done using any good quality wood filler.

Sap - is naturally occurring in wood and may appear in some boards of your garden product. If you wish to remove the sap, we advise waiting until it is dry and then using a sharp knife to carefully remove it. If the removal of the sap causes a hole in the timber, we recommend using a good quality wood filler to fill it.

For more handy hints and tips on how to care and maintain your garden product please refer to the MGP Customer Portal at www.mgplogistics.co.uk

Any further questions?

Contact our
Customer Service
Team on:
01636 821215

1 Manufacturer's Warranty

All Mercia Garden Products are supplied with a 1 year warranty on all parts against manufacturing defects.
This warranty does not cover movement, warping or splitting of timber products over time.

This warranty will be voided if any of the following occur:

1. The product has been customised or modified/adapted in any way.
2. The person claiming is not the original purchaser of the product.
3. Any damage has been caused by or as a result of misuse.
4. The product has not been maintained and cared for in accordance to our advisories and manufacturer's recommendations.
5. The product has not been treated annually or as per the manufacturer's recommendations, please ensure receipts are kept to validate this claim.
6. The product has not been erected, fitted or installed as per the supplier instructions.
7. The product has not been erected on a suitable sized firm flat, solid level concrete/slab base or placed on pressure treated bearers.
8. The product is or has been placed with 2 feet (600mm) of any obstructions (walls, trees, plants, fences etc.) which can allow moisture to penetrate the timber.
9. The roofing felt has been incorrectly fitted or damaged, allowing water ingress, or has not been properly maintained.
10. Any windows and joints have not been sealed, inside and out, with silicone or other watertight sealant.
11. Any timber has been cut, pierced or drilled without subsequent application of approved cut-end treatment.

2 Anti-rot Guarantee

Mercia Garden Products offer a 10 year anti-rot guarantee on all dip treated (a preparatory treatment) and 15 years on all pressure treated products. This guarantee covers solid timber against rot, decay, blue stain and insect attacks.
To validate the guarantee, the product must be treated (as detailed within manufacturer's recommendations) within 14 days (weather permitting) of assembly and annually thereafter.

This guarantee does not cover movement, warping or splitting of timber products over time.

This guarantee will be voided if any of the following occur:

1. The product has been customised or modified/adapted in any way.
2. The person claiming is not the original purchaser of the product.
3. Any damage is caused by or as a result of misuse.
4. The product has not been maintained and cared for in accordance to our advisories and manufacturer's recommendations.
5. The product has not been treated annually or as per the manufacturer's recommendations, please ensure receipts are kept to validate this claim.
6. The product has not been erected, fitted or installed as per the supplier instructions.
7. The product has not been erected on a suitable sized firm flat, solid level concrete/slab base or placed on pressure treated bearers.
8. The product is or has been placed with 600mm of any obstructions (walls, trees, plants, fences etc.) which can allow moisture to penetrate the timber.
9. The roofing felt has been incorrectly fitted or damaged allowing water ingress, or has not been properly maintained.
10. Any windows and joints have not been sealed, inside and out, with silicone or other watertight sealant.
11. Any timber has been cut, pierced or drilled without subsequent application of approved cut-end treatment.



**REGISTER FOR YOUR
ANTI-ROT
GUARANTEE TODAY**

PLEASE SCAN HERE:

