

6FT APEX GREENHOUSE

Please retain product label and instructions for future reference

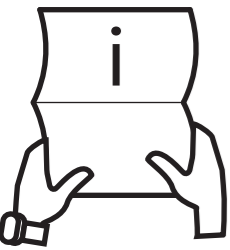

BEFORE YOU START PLEASE READ THE INSTRUCTIONS CAREFULLY

- Check the pack and make sure you have all the items listed in the parts list provided.
- When you are ready to start, make sure you have the right tools at hand (not supplied - see the equipment list on next page).
- Ensure there is plenty of space and a clean dry area for assembly.
- Ensure you have enough time to fully assemble the main structure of your Greenhouse.

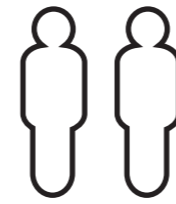

x2

All greenhouses should be erected by two adults.

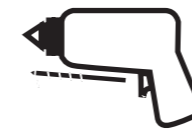

2mm Drill bit

For ease of assembly, you **MUST** pilot drill all screw holes and ensure all screw heads are countersunk.



For ease of assembly, you will need a tape measure to check dimensions of components and fixings.



Winter = High Moisture = Expansion
Summer = Low Moisture = Contraction



CAUTION

Every effort has been made during the manufacturing process to eliminate the prospect of splinters on rough surfaces of the timber. You are strongly advised to wear gloves when working with or handling rough sawn timber.

LOCATION FOR YOUR GREENHOUSE

Ensure you have a suitable space available and cleared before beginning assembly:

- A minimum of 600mm should be left around the perimeter of your Greenhouse to allow access for maintenance, annual treatment and to allow air flow around the building.
- To fit your glazing, you require a minimum of 1000mm clearance on either side of your Greenhouse. These must be the sides where the lowest ends of the roofs (bottom of the apex) will be positioned.
- Where possible, avoid placing your Greenhouse underneath large trees to prevent the tree causing damage to the building.

BUILDING A BASE

When thinking about where the greenhouse and where the base is going to be constructed: Ensure that there will be access to all sides for maintenance work and annual treatment.

Ensure the base is level and is built on firm ground, to prevent movement. Refer to pages 5-6 for the base dimensions. The base should be slightly smaller than the external measurement of the greenhouse, i.e. The cladding should overlap the base, creating a run off for water. It is also recommended that the floor be at least 25mm above the surrounding ground level to avoid flooding.

TYPES OF BASE

- Concrete 75mm laid on top of 75mm hard-core.
- Slabs laid on 50mm of sharp sand.
- Wooden base - Levelled / on posts / ground screws.

TREATMENT

Once your Greenhouse has been installed it will need to be treated within 14 days (weather permitting) and then annually to prevent the timber from deteriorating and to waterproof it. This is required to maintain the anti-rot guarantee.

Dip Treated greenhouses - Require a preservative treatment to protect against rot and decay and a waterproof treatment to prevent water ingress.

TIMBER

As with all natural materials, timber can be affected during various weather conditions. For the duration of heavy or extended periods of rain, swelling of the wood panels may occur. Warping of the wood may also occur during excessive dry spells due to an interior moisture loss. Unfortunately, these processes cannot be avoided but can be helped. It is suggested that the greenhouse is sprayed with water during extended periods of warm sunshine and sheltered as much as possible during rain or snow.

REGISTER FOR YOUR
15 YEAR
ANTI-ROT
GUARANTEE TODAY

In all instances for assistance with your product or to register your anti rot guarantee, please contact us via our customer portal



www.mgplogistics.co.uk

Mercia Garden Products Limited, Sutton On Trent, Newark, Nottinghamshire, NG23 6QN

Screws & Nails

Measure overall length

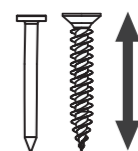

Bolts

Measure under the head



****Protim Aquatan T5 (621)****

Your greenhouse has been dip treated with Aquatan.

Aquatan is a water-based concentrate which is diluted with water, the building has been treated by the correct application of Aquatan solution and then allowed to dry.

Aquatan is a decorative finish to colour the wood, which is applied industrially to timber fence panels and garden buildings.

Aquatan undiluted contains: boric acid, sodium hydroxide 32% solution, aqueous mixture of sodium dioctyl sulphosuccinat and alcohols: 2, 4, 6-trichlorophenol.



TO DO LIST

- Find a suitable location to build (*see front cover for further information*).
- Build a base (*see front cover for further information*).
- Check the base is flat, level, clear of debris and has the required clearance on all sides (see page 1).
- Check you have the required equipment / tools.
- Check you have all the product items listed (*if you have missing or damaged parts please scan the QR code below to visit our online customer portal*).
- Install the product as per the step by step instructions within this pack.
- Prepare the product ready for treatment (this may include sanding).
- Apply a preserving and a waterproofing treatment within 14 days (*Weather permitting*) of installation (*pressure treated products do not require a preserver*).
- Register for your anti rot guarantee (*scan the QR below*).
- Tidy the build area and dispose of any remaining parts responsibly.
- Maintain your greenhouse (*see the manufacturers recommendations at the back of this pack*).

EQUIPMENT LIST

- Hammer
- Flat Head Screwdriver
- Drill
- Drill Bit Set
- Phillips and Slotted Bit Sets
- Tape Measure
- Hand Saw
- Spirit Level
- Ladders/Steps
- Stanley Knife/Cutting Tool
- Sand Paper
- Gloves
- Silicone (For Windows Only)
- Sealant Application Gun
- Wood Filler (Optional)
- Timber Preservative Treatment (*not pressure treated products*)
- Timber Water Proofing Treatment
- Treatment Mixing Stick
- Paint Brush/Sprayer/Roller

NEED EXTRA SUPPORT

If you are unsure that your base preparation will be suitable, please contact us via our customer portal to discuss this further.

Alternatively, you can visit our website or MGP Logistics Online Portal for some further shededucation.

Website:

<https://www.merciagardenproducts.co.uk/sheducation>

MGP Logistics Online Portal:

<https://www.mgplogistics.co.uk/>

Here you will find plenty of useful information that'll help with most pre-installation and maintenance queries.



ANY QUESTIONS?

Scan the QR code to contact us via our customer portal.

NOTES

ACCESSING VIDEO GUIDES...

Some steps within this set of instructions come with an added video guide for your convenience. These can be accessed via the QR code and used to aid you in constructing that step. See below for how to use.

You can also find all the videos on our youtube channel:
<https://www.youtube.com/@merciagardenproducts8716/videos>

1. Find the QR code within the instruction step...

Step.....

Parts Needed- No. QTY 1
No. QTY 1
No. QTY 1

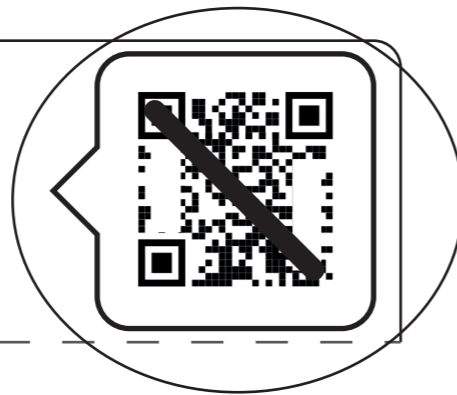

Within the instruction step, there will be an icon in the top right that has a QR code in. This is where the video can be accessed from.

Please note: not every step has a video guide.

2. Open camera app...

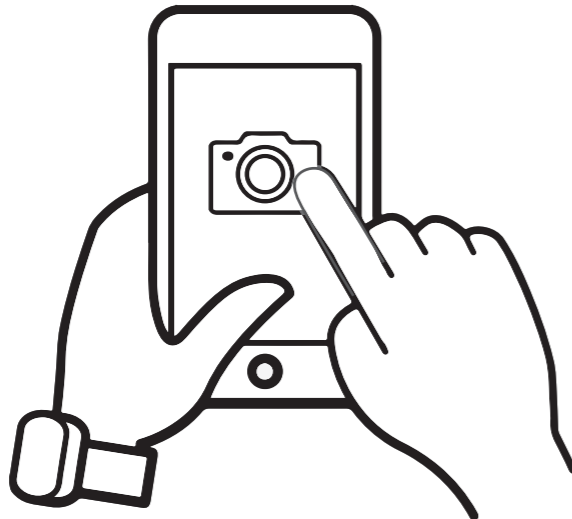

On your personal smart device (phone, tablet etc), open your camera app or QR code scanner app.

ACCESSING VIDEO GUIDES...

3. Scan QR code...



To scan the QR code, hold the camera over the QR code so that it can be seen on the screen. Once the QR code has been registered, follow the prompts on your device to open the video. (This will vary depending on your device.)

Please note: Ensure to use the back camera of your smart device as this will scan the QR code more accurately.

4. Watch the video...



The video guide will now be displayed on your smart device.

Disclaimer: The garden building constructed in the video guides may be constructed differently to your building. Please ensure to read your instructions carefully to avoid error.

What is a Modular Greenhouse?

A Modular Greenhouse allows you to choose the layout of your Greenhouse, yourself.

The 2ft Door and Glazed Panels (No. 1a & 1b) are interchangeable with each other, and can be swapped and positioned however you choose.

Please note: The buildings shown may differ in size from your chosen building however the process of interchanging the Panels is the same.

How should I position my panels?

This instruction manual contains steps to construct three different building sizes;

- 4x6 Apex Greenhouse
- 6x6 Apex Greenhouse
- 8x6 Apex Greenhouse

Each of these buildings can be constructed with the panels in different configurations, as explained above.

Please see the following pages for some inspiration of different ways you can position your panels for your chosen building size and type. Ensure you have decided how you would like your building to look before beginning construction.

We recommend positioning your Door centrally on one end, as this allows for the most usable space inside your Greenhouse. However, the Door can be placed in any position.

What building do I have?

All of our modular Greenhouses have different names and different components, so it's important to understand what building you have and what comes with it before beginning assembly. Please refer to the information below to check what type of building you have before beginning construction.

6ft Apex Greenhouse.

The building you have purchased is referred to generically as a '6ft Apex Greenhouse' and this instruction manual contains steps to construct three different sized buildings;

- 4x6 Apex Greenhouse
- 6x6 Apex Greenhouse
- 8x6 Apex Greenhouse

You will have purchased one of these buildings and have the components to build only that. For your exact building reference codes and a full building breakdown, please see the pages to follow that contain your chosen building size. For base options, please see the 6ft Base assembly instructions guide.

What does the building name mean?

The building you have purchased will be named as shown above, for example: 8x6 Apex Greenhouse.

8x6 Apex Greenhouse:

8 - the depth of the building. This building is 8ft deep.

6 - the width of the building. This building is 6ft wide.

Apex - the roof type. An Apex roof is where the roof shape meets at a central point and can look like a triangle.

Greenhouse - the building structure. This building is a greenhouse, which means the majority of wall and roof panels are glazed.

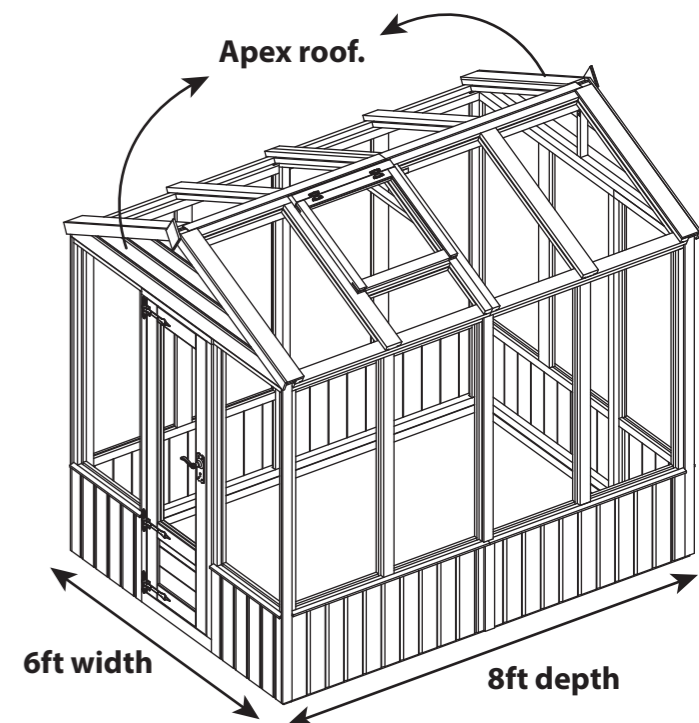

All of the Greenhouses in this manual are 6ft wide, with differing depths. Throughout the instructions, ensure to check that you are referring to the correct building where necessary.



ANY QUESTIONS?

Scan the QR code to contact us via our customer portal.

4x6

Standard base

Overall Dimensions: Width = 1873mm
Depth = 1316mm
Height = 2286mm
Base Dimensions: Width = 1770mm
Depth = 1268mm

Premium base

Overall Dimensions: Width = 1873mm
Depth = 1316mm
Height = 2300mm
Base Dimensions: Width = 1770mm
Depth = 1240mm

Standard base + Height Extension

Overall Dimensions: Width = 1873mm
Depth = 1316mm
Height = 2397mm
Base Dimensions: Width = 1770mm
Depth = 1268mm

Premium base + Height Extension

Overall Dimensions: Width = 1873mm
Depth = 1316mm
Height = 2411mm
Base Dimensions: Width = 1770mm
Depth = 1240mm

Door on the End **Recommended*

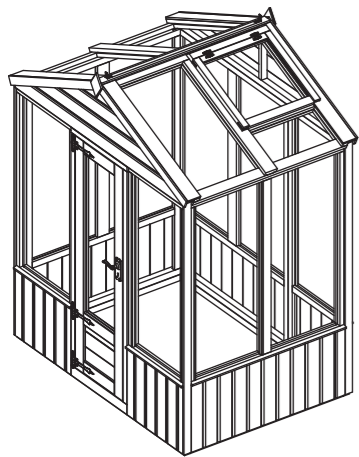

Standard

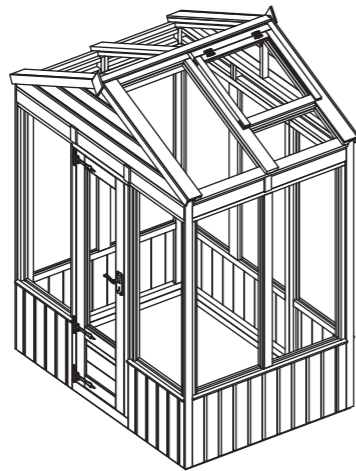

Height Extension

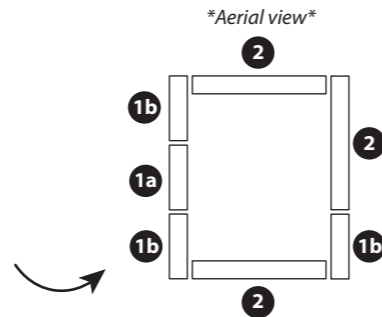

Door on the side

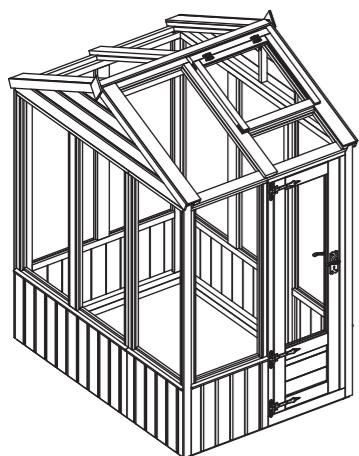

Standard

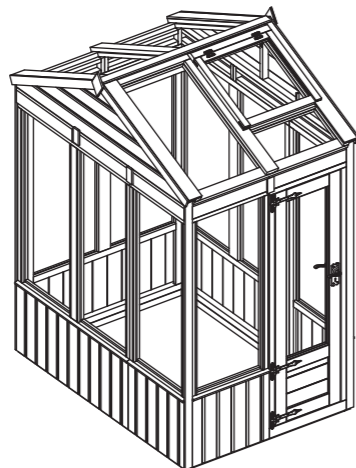

Height Extension

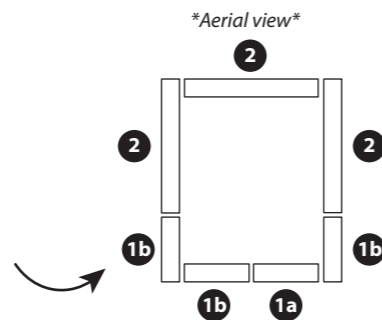

6x6

Standard base

Overall Dimensions: Width = 1873mm
Depth = 1906mm
Height = 2286mm
Base Dimensions: Width = 1770mm
Depth = 1858mm

Premium base

Overall Dimensions: Width = 1873mm
Depth = 1906mm
Height = 2300mm
Base Dimensions: Width = 1770mm
Depth = 1830mm

Standard base + Height Extension

Overall Dimensions: Width = 1873mm
Depth = 1906mm
Height = 2397mm
Base Dimensions: Width = 1770mm
Depth = 1858mm

Premium base + Height Extension

Overall Dimensions: Width = 1873mm
Depth = 1906mm
Height = 2411mm
Base Dimensions: Width = 1770mm
Depth = 1830mm

Door on the End **Recommended*

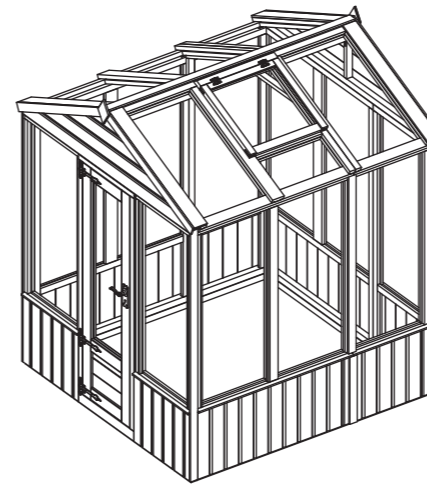

Standard

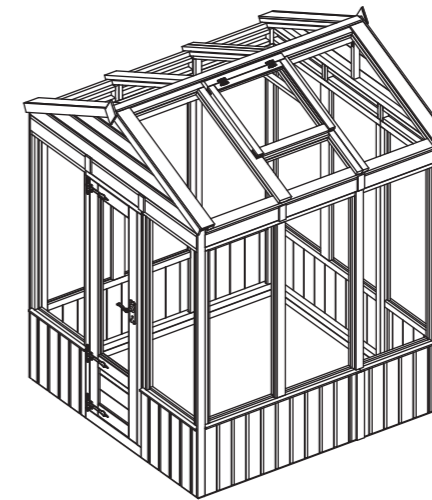

Height Extension

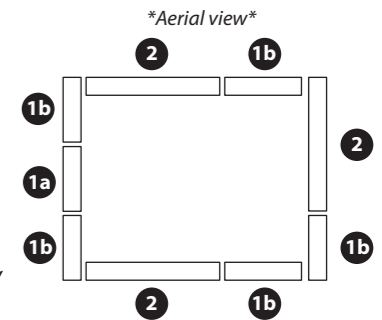

Door on the side

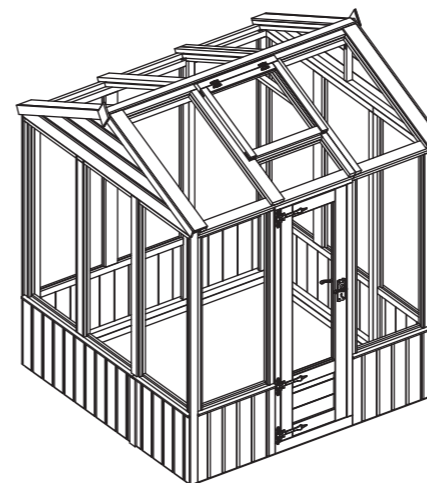

Standard

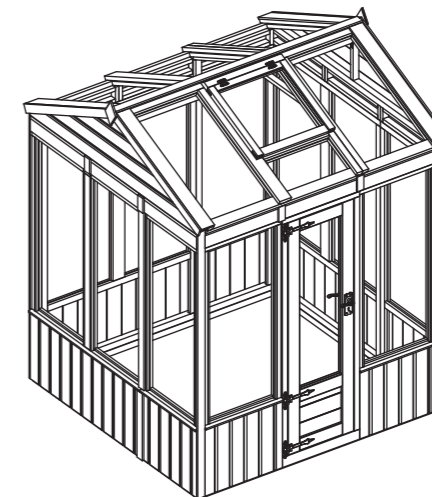

Height Extension

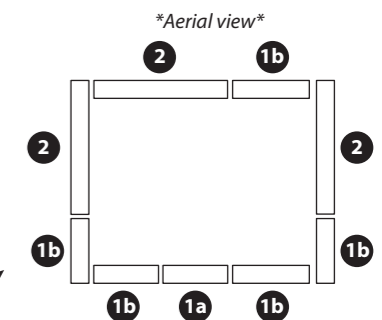

Building Breakdown

Main Buildings:

- SI-100-004-0001 - 4x6 Apex Greenhouse with Styrene
- SI-100-004-0002 - 4x6 Apex Greenhouse with Polycarbonate
- SI-100-004-0003 - 4x6 Apex Greenhouse with Glass

Upgrades:

- SI-100-004-0005 - 4x6 Additional Height

Building Breakdown

Main Buildings:

- SI-100-004-0009 - 6x6 Apex Greenhouse with Styrene
- SI-100-004-0010 - 6x6 Apex Greenhouse with Polycarbonate
- SI-100-004-0011 - 6x6 Apex Greenhouse with Glass

Upgrades:

- SI-100-004-0013 - 6x6 Additional Height

8x6

Standard base

Overall Dimensions: Width = 1873mm
Depth = 2496mm
Height = 2286mm

Base Dimensions: Width = 1770mm
Depth = 2448mm

Standard base + Height Extension

Overall Dimensions: Width = 1873mm
Depth = 2496mm
Height = 2397mm

Base Dimensions: Width = 1770mm
Depth = 2448mm

Premium base

Overall Dimensions: Width = 1873mm
Depth = 2496mm
Height = 2300mm

Base Dimensions: Width = 1770mm
Depth = 2420mm

Premium base + Height Extension

Overall Dimensions: Width = 1873mm
Depth = 2496mm
Height = 2411mm

Base Dimensions: Width = 1770mm
Depth = 2420mm

Door on the End **Recommended*

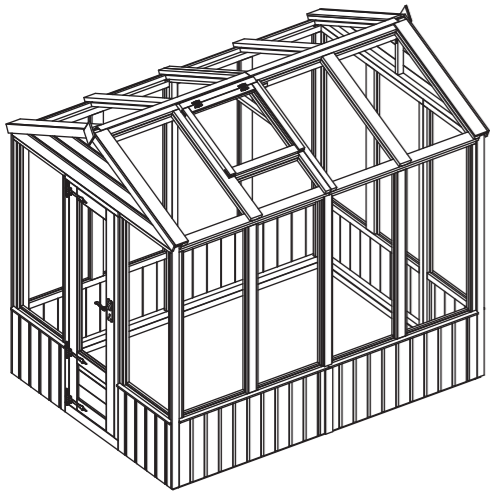

Standard

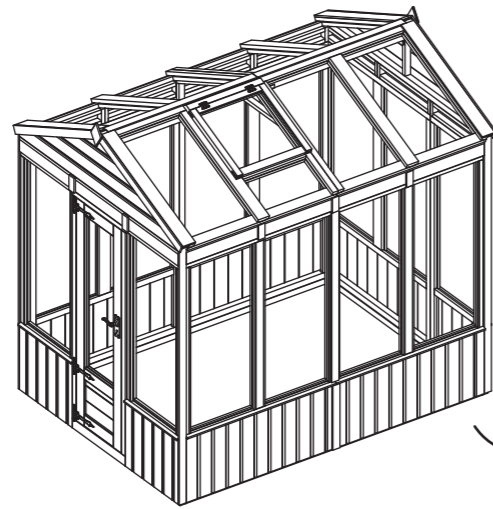

Height Extension

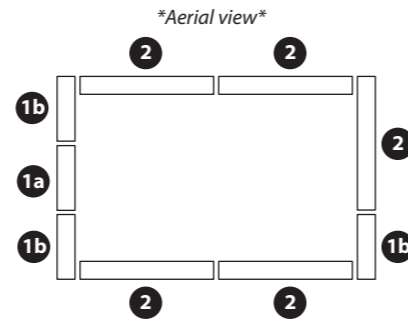

Door on the side

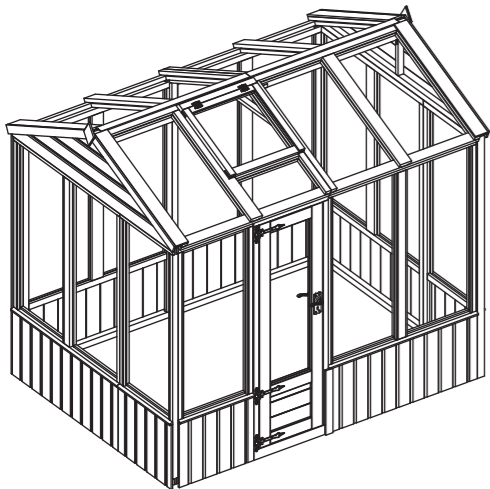

Standard

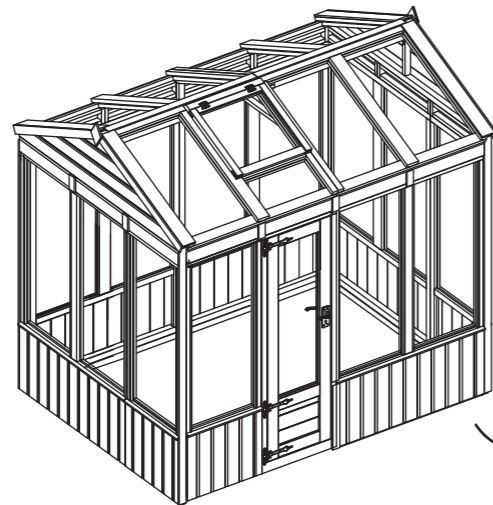

Height Extension

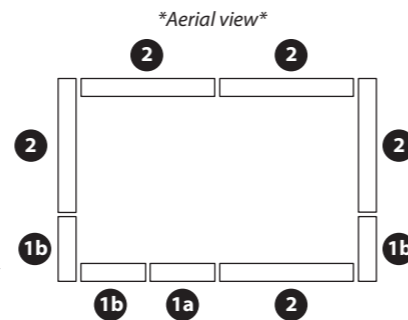

Building Breakdown

Main Buildings:

- SI-100-004-0017 - 8x6 Apex Greenhouse with Styrene
- SI-100-004-0018 - 8x6 Apex Greenhouse with Polycarbonate
- SI-100-004-0019 - 8x6 Apex Greenhouse with Glass

Upgrades:

- SI-100-004-0021 - 8x6 Additional Height

Building Contents:

In the tables to follow, please refer to the row with your chosen building size in to determine how many of each part is required.

Tip: Labelling your parts, using a pencil and masking tape, may help you to identify them easier when you need them.



We highly recommend checking you have all the required components before beginning assembly.

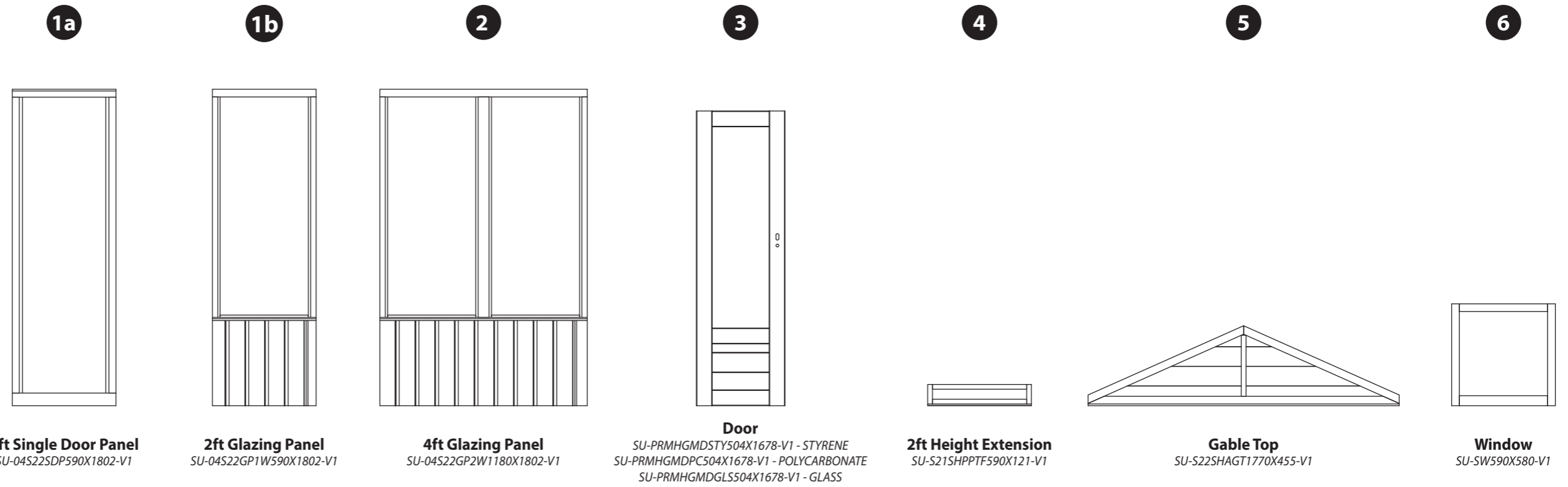

4 X 6 APEX GREENHOUSE	QTY 1	QTY 3	QTY 3	QTY 1	QTY 10	QTY 2	QTY 1
6 X 6 APEX GREENHOUSE	QTY 1	QTY 5	QTY 3	QTY 1	QTY 12	QTY 2	QTY 1
8 X 6 APEX GREENHOUSE	QTY 1	QTY 3	QTY 5	QTY 1	QTY 14	QTY 2	QTY 1

*Included with
'Additional Height
upgrade' only.*

Building Contents:

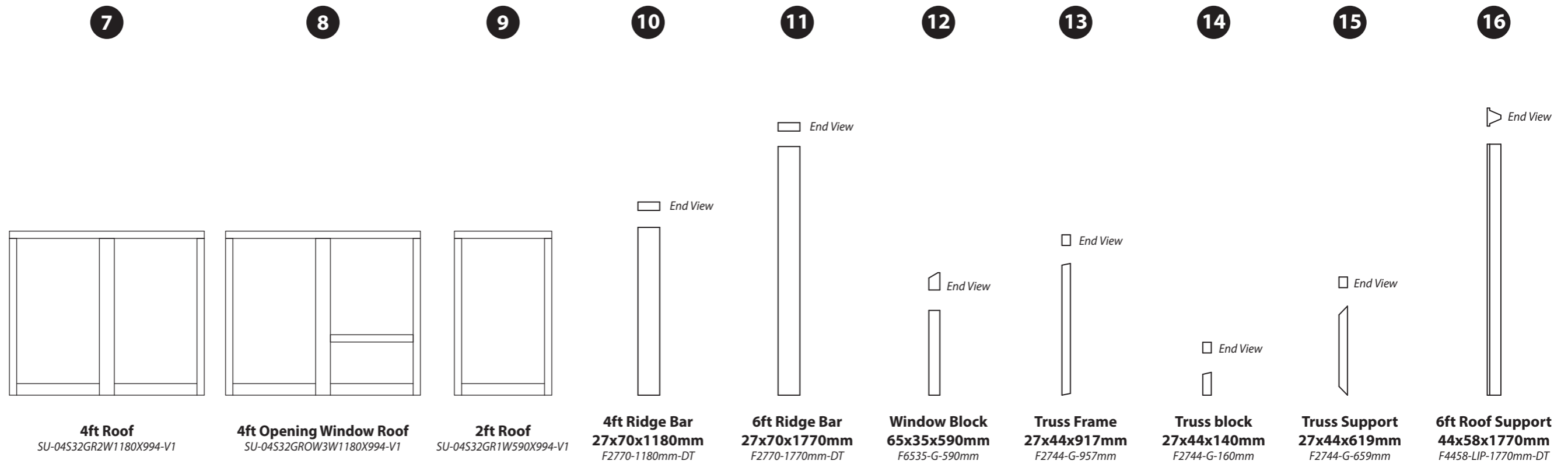

4 X 6 APEX GREENHOUSE	QTY 1	QTY 1	-	QTY 1	-	QTY 1	-	-	-
6 X 6 APEX GREENHOUSE	QTY 1	QTY 1	QTY 2	-	QTY 1	QTY 1	QTY 2	QTY 2	QTY 1
8 X 6 APEX GREENHOUSE	QTY 3	QTY 1	-	QTY 2	-	QTY 1	QTY 2	QTY 2	QTY 1

****This part will be longer than needed and requires cutting to size when used. This will be explained when required within the instruction step.**

Note: one piece may be required to be cut into multiple different sizes. Do not dispose of off-cuts until the building is fully constructed as they may be needed in another step.

Building Contents:

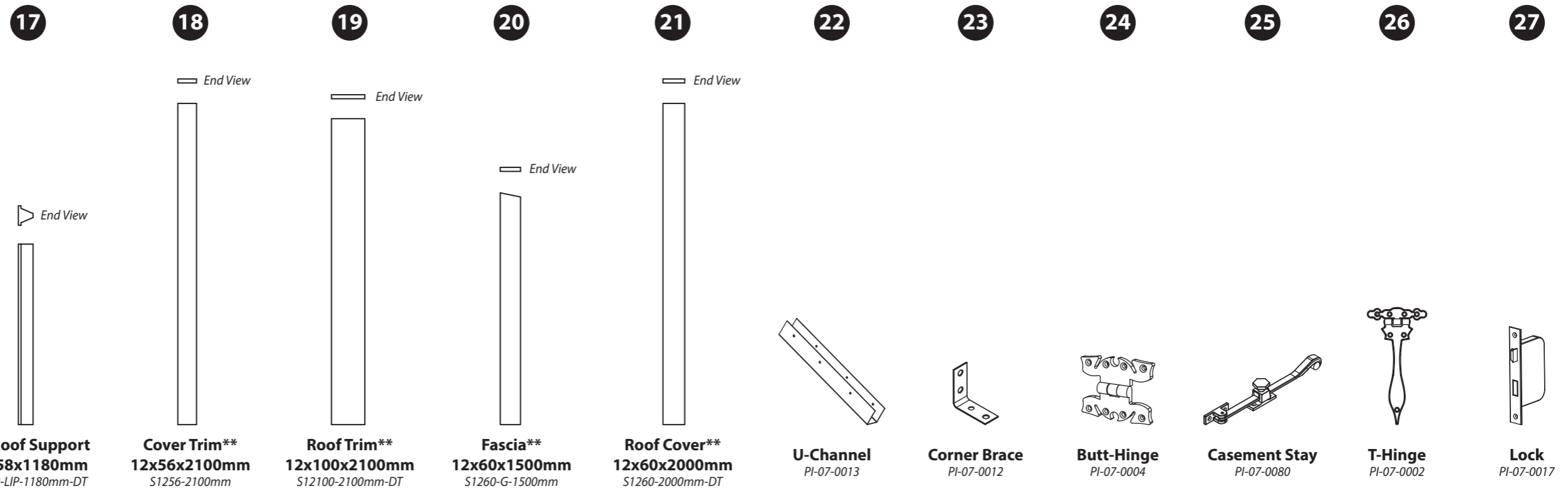

	17	18	19	20	21	22	23	24	25	26	27
4 X 6 APEX GREENHOUSE	QTY 1	QTY 12*	QTY 2	QTY 4	QTY 1	-	QTY 2	QTY 2	QTY 1	QTY 3	QTY 1
6 X 6 APEX GREENHOUSE	-	QTY 12*	QTY 2	QTY 4	QTY 1	-	QTY 2	QTY 2	QTY 1	QTY 3	QTY 1
8 X 6 APEX GREENHOUSE	QTY 2	QTY 12*	QTY 2	QTY 4	QTY 2	QTY 1	QTY 2	QTY 2	QTY 1	QTY 3	QTY 1

*You may have more of this part that required.

**This part will be longer than needed and requires cutting to size when used. This will be explained when required within the instruction step.

Note: one piece may be required to be cut into multiple different sizes. Do not dispose of off-cuts until the building is fully constructed as they may be needed in another step.

Building Contents:

28



Key-Plate
PI-07-0017

29

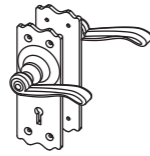

Handle Set
PI-07-0006

30



Finial
SHED DIAMOND FINIAL

	28	29	30
4 X 6 APEX GREENHOUSE	QTY 1	QTY 1	QTY 2
6 X 6 APEX GREENHOUSE	QTY 1	QTY 1	QTY 2
8 X 6 APEX GREENHOUSE	QTY 1	QTY 1	QTY 2

Screw Packs

In the table below, please refer to the row with your chosen building size and type in to determine how many of each screw is required.

There may be extra screws in the pack.



70mm
Screw



60mm
Screw



50mm
Screw



40mm
Screw

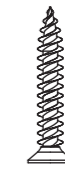

30mm
Screw



30mm Black
Screw



16mm Black
Screw

	70mm Screw	60mm Screw	50mm Screw	40mm Screw	30mm Screw	30mm Black Screw	16mm Black Screw
4 X 6 APEX GREENHOUSE	QTY 33	QTY 29	QTY 54	QTY 16	QTY 71	QTY 51	QTY 4
6 X 6 APEX GREENHOUSE	QTY 47	QTY 35	QTY 80	QTY 20	QTY 87	QTY 51	QTY 4
8 X 6 APEX GREENHOUSE	QTY 51	QTY 35	QTY 96	QTY 20	QTY 104	QTY 51	QTY 4



Missing parts?

Scan the QR code to visit our customer portal where you can quickly raise any missing or damaged parts and get a replacement sent out ASAP.



Step 1

		Parts Needed			
Building	No. 1a	No. 3	No. 26	30mm black screw	
All sizes	QTY 1	QTY 1	QTY 3	QTY 27	

IMPORTANT: Pre-drill before fixing screws.

- a** Lay the 2ft Single Door Panel (**No. 1a**) face up on a flat and level surface.

To ensure the panel is the correct way up, check that the internal lips on either side of the upright framing are visible.

- b** Place the Door (**No. 3**) within the Door Panel opening so it is sat on the internal lipped edges.

Ensure there is equal spacing on all sides and that the cut outs on the Door are lined up with the cut out in the door frame.

Locate the T-Hinges (**No. 26**) onto the Door and Door Panel, ensuring the Hinges line up with the Door framing.

Secure in place using 9x30mm black screws per hinge.

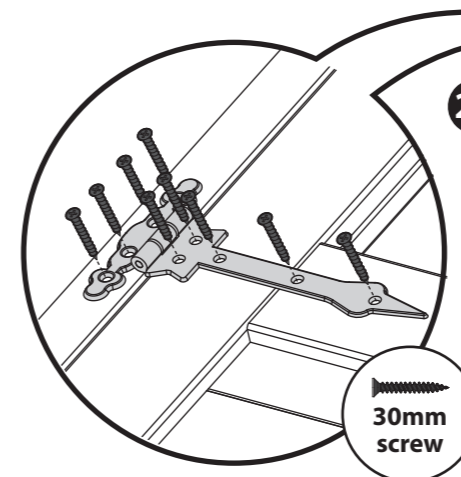
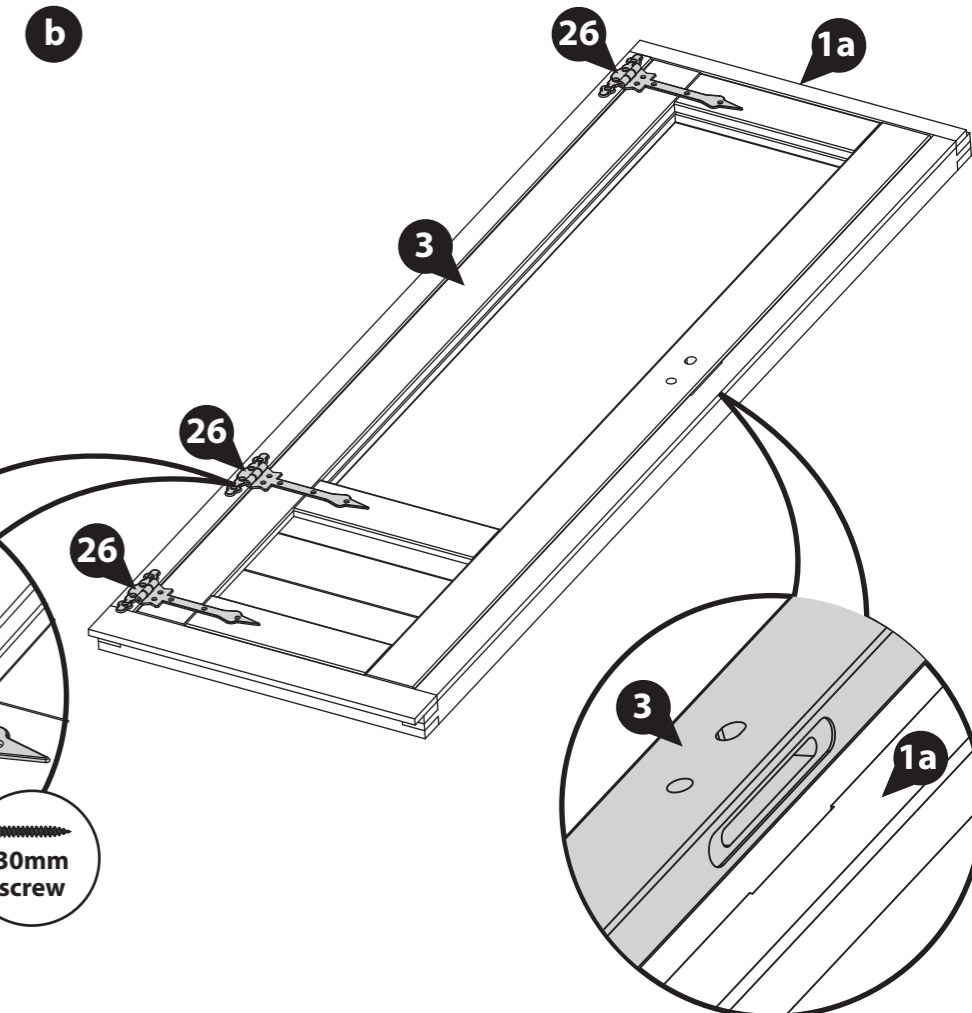
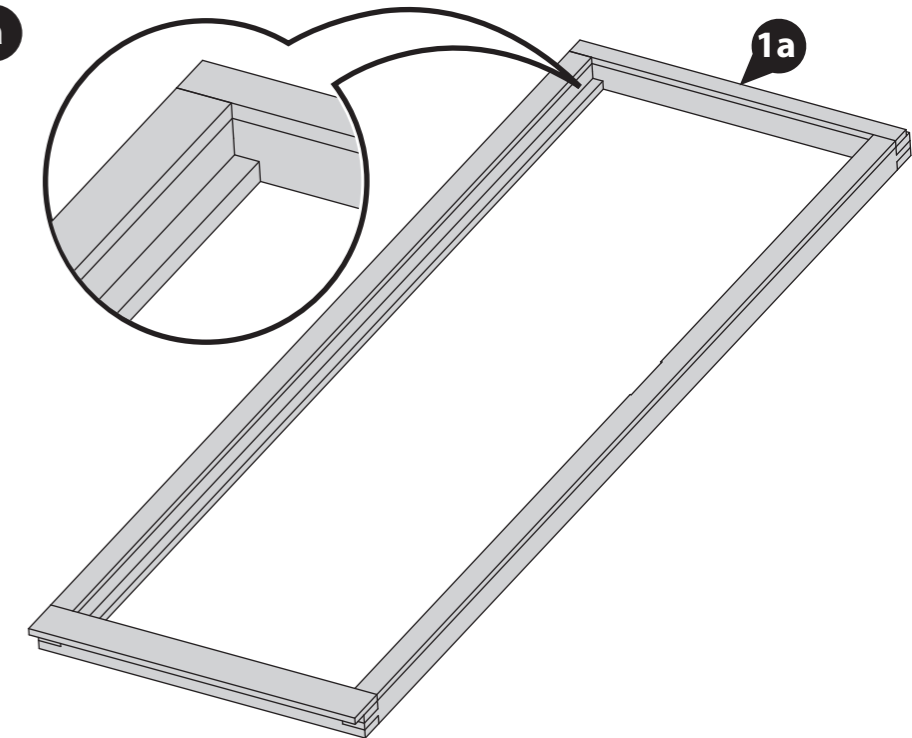

Before assembly, please make sure you have followed instructions to assemble your Greenhouse Base frame.

If not, please refer to the '6ft Base frame construction' manual provided with your building.

This must be constructed before assembling your Greenhouse.

Step 2

Parts Needed

Building	No. 27	No. 28	30mm screw
All sizes	QTY 1	QTY 1	QTY 4

Open the Door and locate the Lock (No. 27) into the recess of the Door (No. 3). Fix in place using 2x30mm screws.

Locate the Key-Plate (No. 28) onto the recess on the inside of the Door Panel (No. 1a). Fix in place using 2x30mm screws.

Do NOT shut the door fully until the Handle Set has been fitted in step 3.

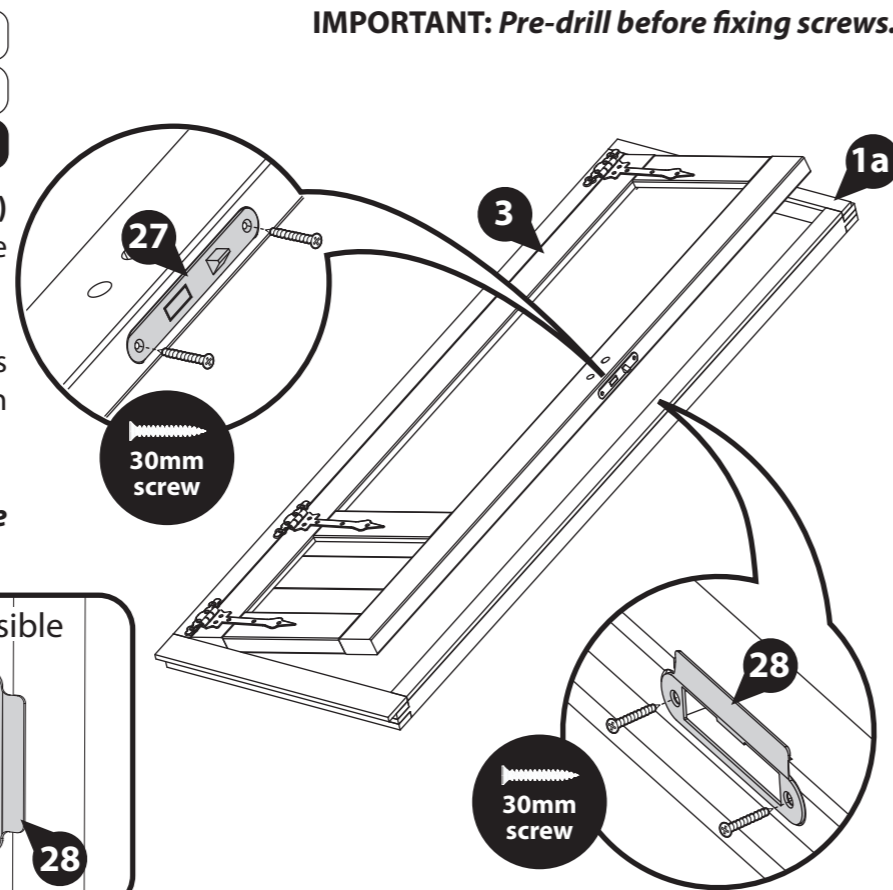
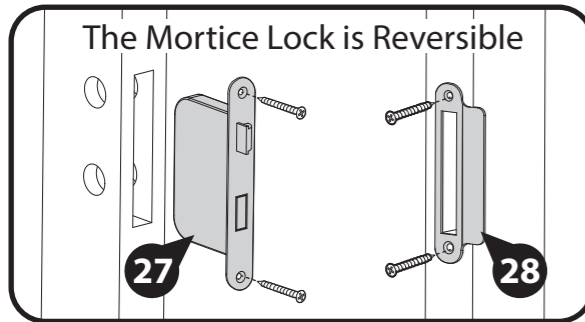

IMPORTANT: Pre-drill before fixing screws.

IMPORTANT: Pre-drill before fixing screws.

Step 3

Parts Needed

Building	No. 29	30mm black screw
All sizes	QTY 1	QTY 8

From the Handle Set (No. 29) position the Metal Bar through the Door and lock and connect one handle onto either side, as shown.

Fix each Handle in place using 4x30mm black screws.

Before closing the door, ensure the door mechanism works by checking that the lock (No. 27) moves with the Handle set.

Then, check the door can open and close freely.

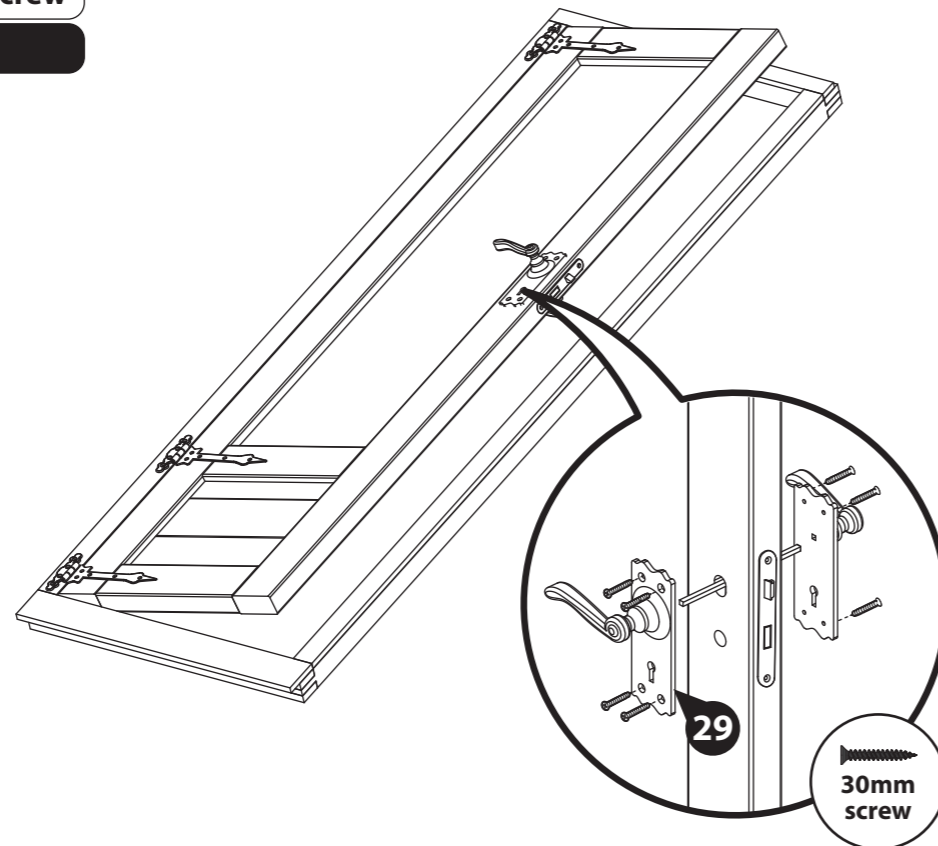

Step 4

a Before assembling the Greenhouse walls, ensure you have constructed your Greenhouse Base framing and that it is square and level.

If not, please refer to the '6ft Base frame' instruction manual provided with your building.

b With your base constructed, decide how you want your interchangeable panels to sit.

We recommend positioning your Door centrally on one end, as this allows for the most usable space inside your Greenhouse. However, the Door can be placed in any position.

It is advised to lay your panels around the base frame in the desired positions, an example is shown below.

Please note: the 8x6 'Door on the end' building configuration has been shown for illustrative purposes and may differ from your chosen configuration. However, the process of laying out the Panels is the same.

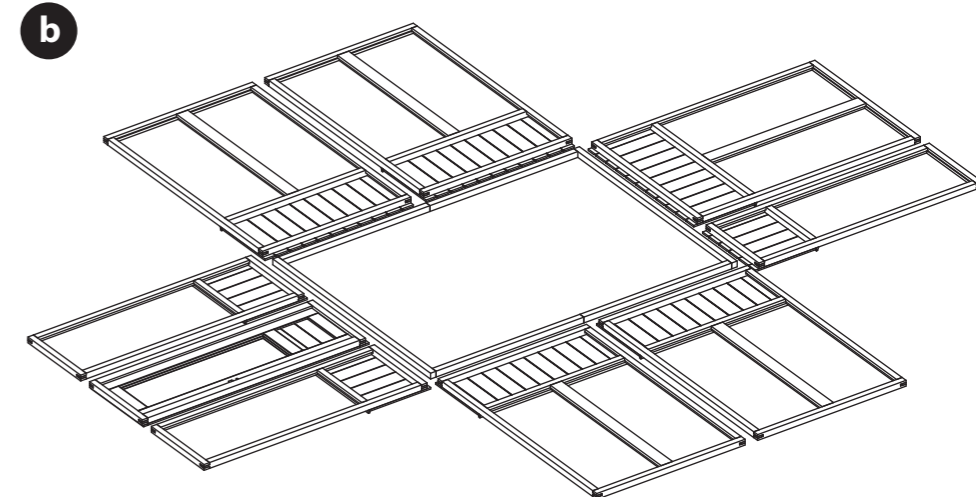
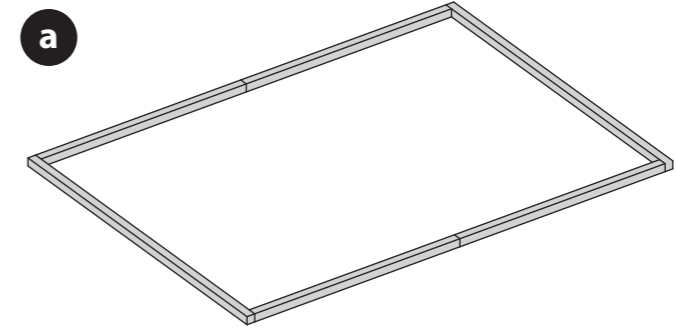

IMPORTANT: Pre-drill before fixing screws.

Step 5

Parts Needed			
Building	No. 1 (a or b)	No. 2	60mm screw
4x6	-	QTY 2	QTY 3
6x6	QTY 1	QTY 1	QTY 3
8x6	-	QTY 2	QTY 3

****Please note: the 2ft panels (No. 1a & 1b) are interchangeable and can be positioned in a variety of different configurations. Decide which works best for you before assembly.**

Locate a 4ft Glazing Panels (**No. 2**) on top of the base frame at one end. On the inside of the end panel, create the corner by positioning a:

4x6 & 8x6: 4ft Glazing Panel (**No. 2**).

6x6: 2ft Panel (**No. 1a or 1b**).

Secure the Panels together at the corner using 3x60mm screws, as shown.

Make sure to position the Panels so there is equal spacing between the overhanging cladding and the base frame on all sides.

Do NOT secure the building to the base frame until the roof has been fitted.

Please note: the 'Door on the end' building configuration has been shown for illustrative purposes and may differ from your chosen configuration. However, the process of fitting the Panels is the same.

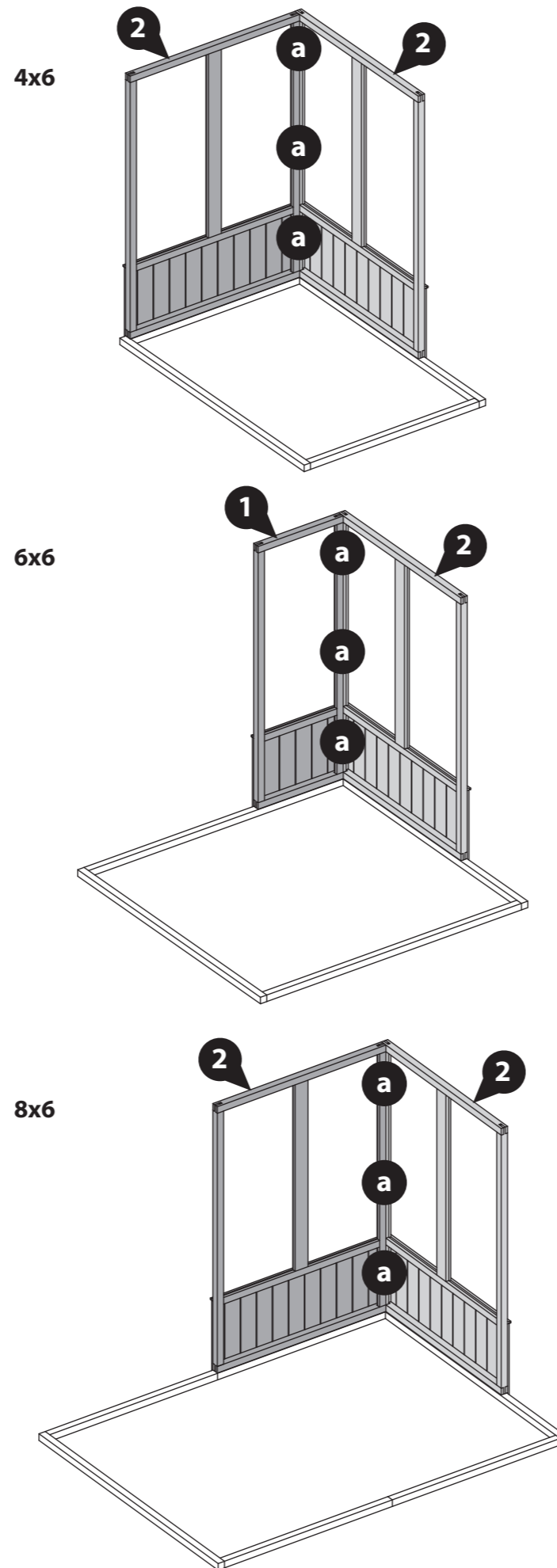
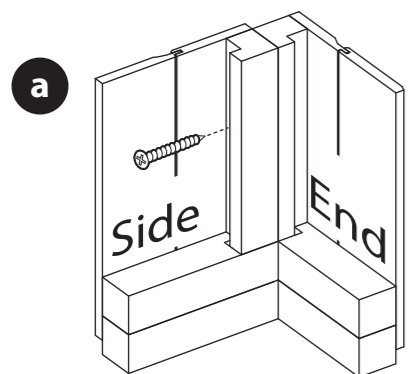

Step 6

		Parts Needed		
Building	No. 1 (a or b)	No. 2	60mm screw	
4x6	QTY 1	-	QTY 3	
6x6	QTY 1	QTY 1	QTY 6	
8x6	QTY 1	QTY 1	QTY 6	

Locate one 2ft Panel (**No. 1a or 1b**) next to the Panel on the end, as shown.

6x6 & 8x6 only: Next to the previously placed Panel on the side, position one 4ft Glazing Panel (**No. 2**).

Secure the Panels together using 3x60mm screws, as shown.

Make sure to position the Panels so there is equal spacing between the overhanging cladding and the base frame on all sides.

Do NOT secure the building to the base frame until the roof has been fitted.

Please note: the 'Door on the end' building configuration has been shown for illustrative purposes and may differ from your chosen configuration. However, the process of fitting the Panels is the same.



4x6

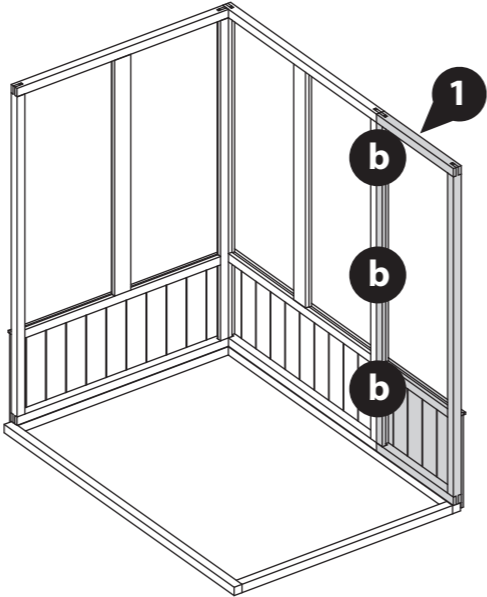

6x6

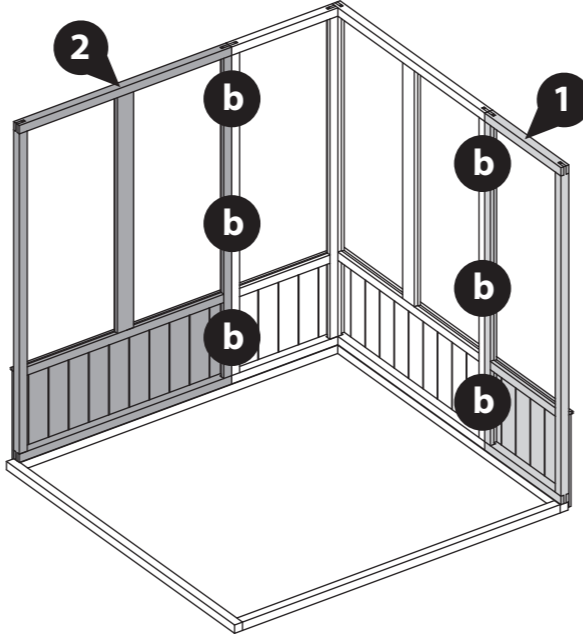

8x6

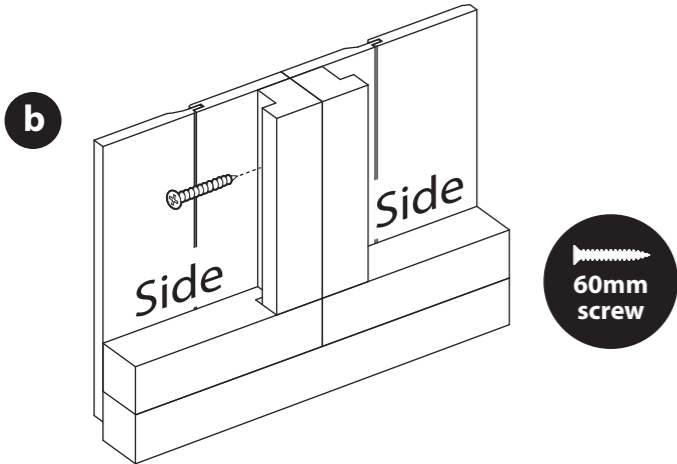
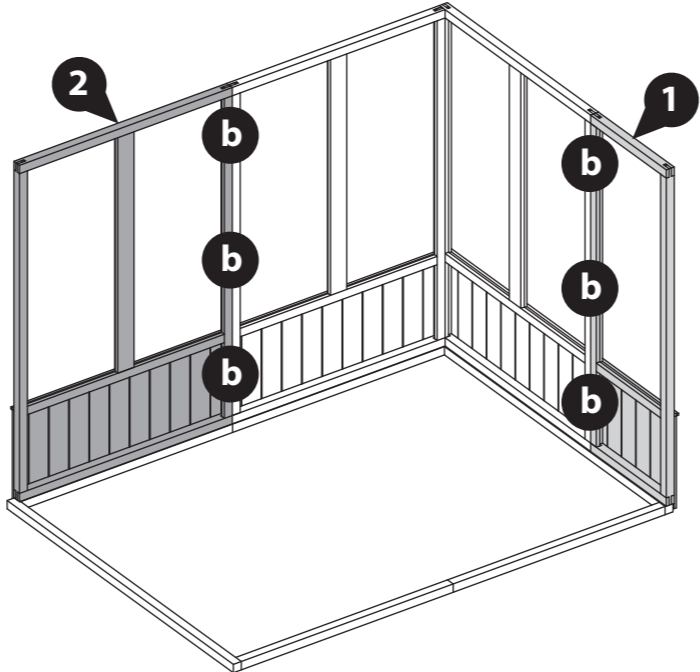

IMPORTANT: Pre-drill before fixing screws.

IMPORTANT: Pre-drill before fixing screws.

Step 7

Parts Needed

Building	No. 1 (a or b)	No. 2	60mm screw
4x6	-	QTY 1	QTY 3
6x6	QTY 1	-	QTY 3
8x6	-	QTY 1	QTY 3

On the inside of the previously fitted 2ft Panel (No. 1a or 1b), create the corner by positioning one:

4x6 & 8x6: 4ft Glazing Panel (No. 2).

6x6: 2ft Panel (No. 1a or 1b).

Secure the Panels together at the corner using 3x60mm screws, as shown.

Make sure to position the Panels so there is equal spacing between the overhanging cladding and the base frame on all sides.

Do NOT secure the building to the base frame until the roof has been fitted.

Please note: the 'Door on the end' building configuration has been shown for illustrative purposes and may differ from your chosen configuration. However, the process of fitting the Panels is the same.



a

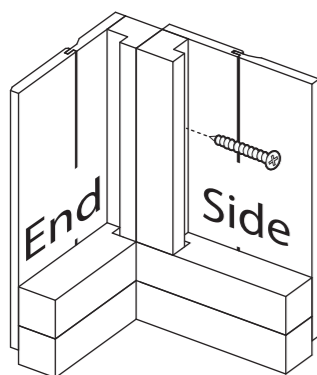

4x6

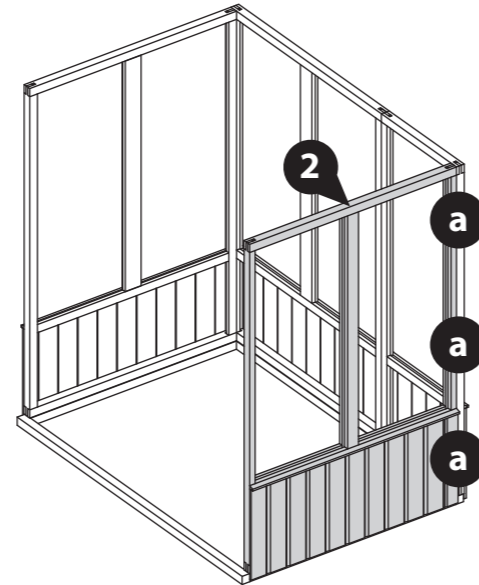

6x6

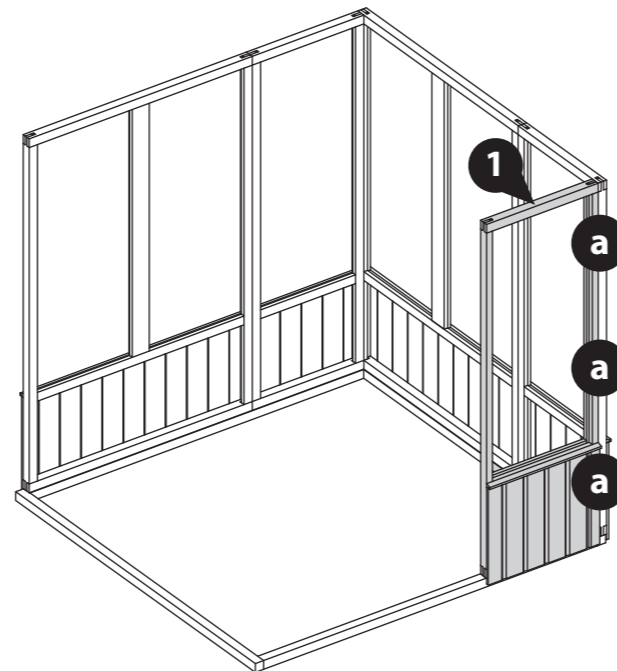

8x6

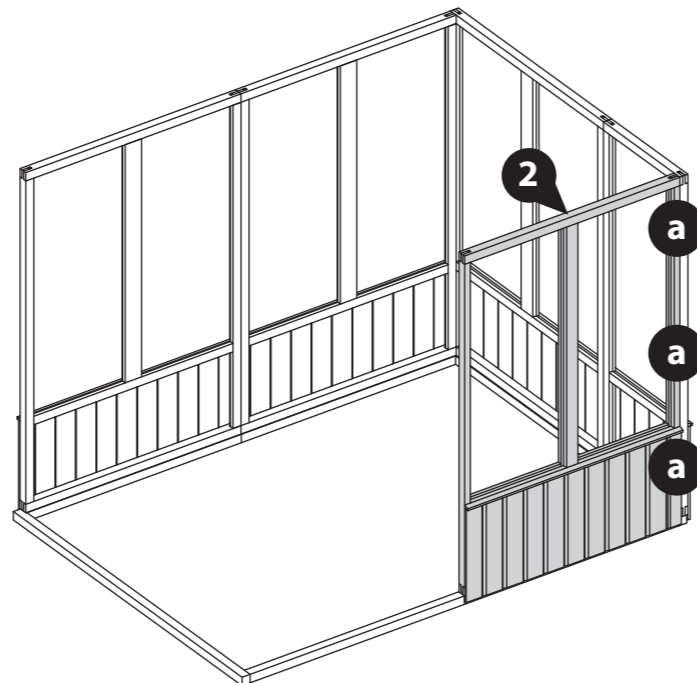

IMPORTANT: Pre-drill before fixing screws.

Step 8

Parts Needed

Building	No. 2	60mm screw
4x6	-	-
6x6	QTY 1	QTY 3
8x6	QTY 1	QTY 3

If you have purchased a 4x6 building, please skip to the next step (Step 9).

Locate one 4ft Glazing Panel (**No. 2**) next to the previously placed Panel on the side, as shown.

Secure the Panels together using 3x60mm screws, as shown.

Make sure to position the Panels so there is equal spacing between the overhanging cladding and the base frame on all sides.

Do NOT secure the building to the base frame until the roof has been fitted.

Please note: the 'Door on the end' building configuration has been shown for illustrative purposes and may differ from your chosen configuration. However, the process of fitting the Panels is the same.

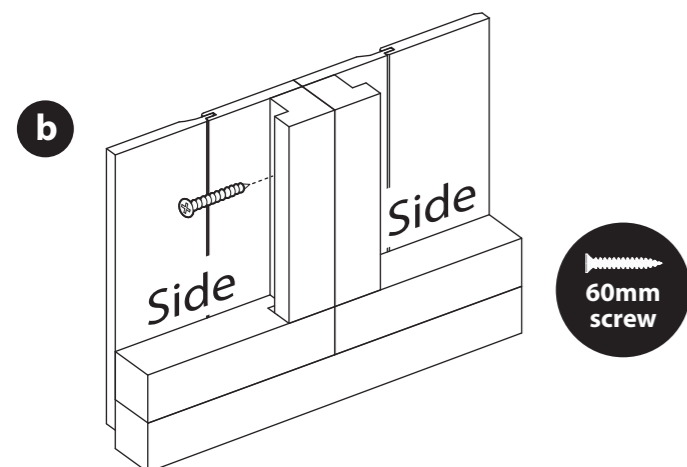

4x6

If you have purchased a 4x6 building, please skip to the next step (Step 9).

6x6

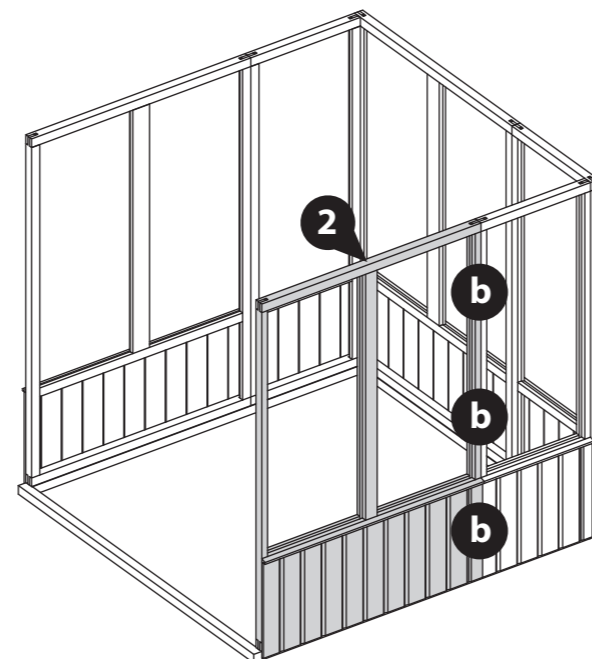

8x6

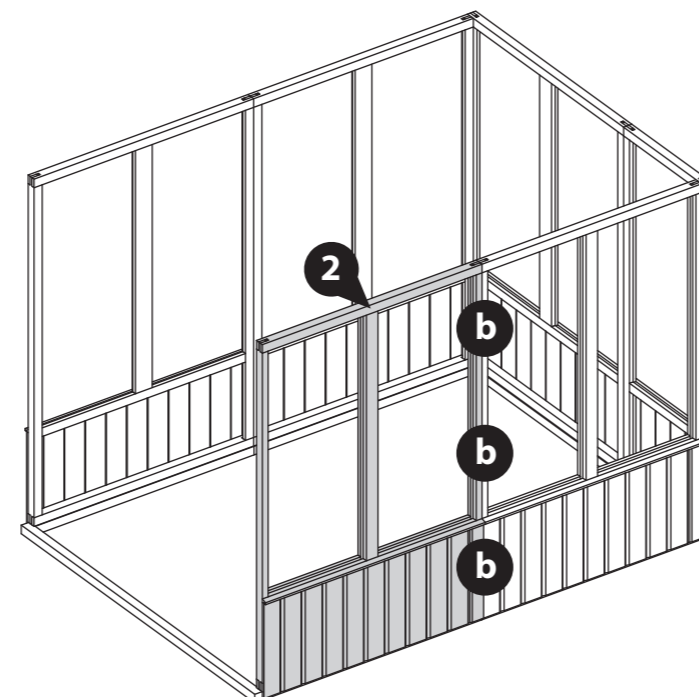

Step 9

Parts Needed

Building	No. 1 (a or b)	60mm screw
All sizes	QTY 3	QTY 12

Locate the remaining 2ft Panels (No. 1a or 1b) on top of the floor at the end, ensuring they sit on the outside of the previously placed panels, as shown.

Fix the Panels together using 3x60mm screws per join, as shown.

Secure the Panels together at the corners using 3x60mm screws per corner.

Make sure to position the Panels so there is equal spacing between the overhanging cladding and the base frame on all sides.

Do NOT secure the building to the base frame until the roof has been fitted.

Please note: the 'Door on the end' building configuration has been shown for illustrative purposes and may differ from your chosen configuration. However, the process of fitting the Panels is the same.

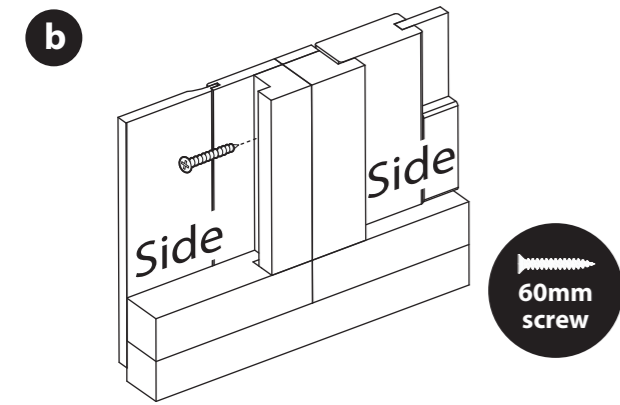
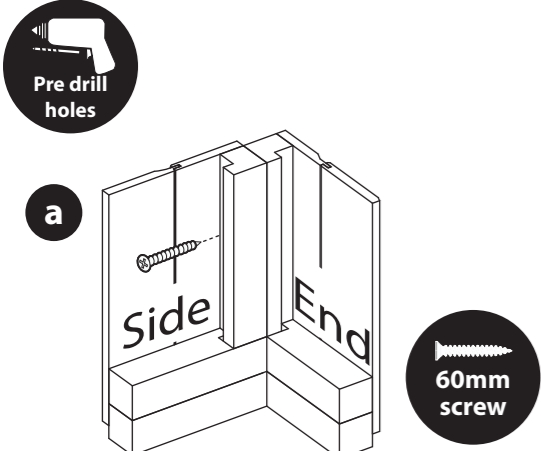

IMPORTANT: Pre-drill before fixing screws.

4x6

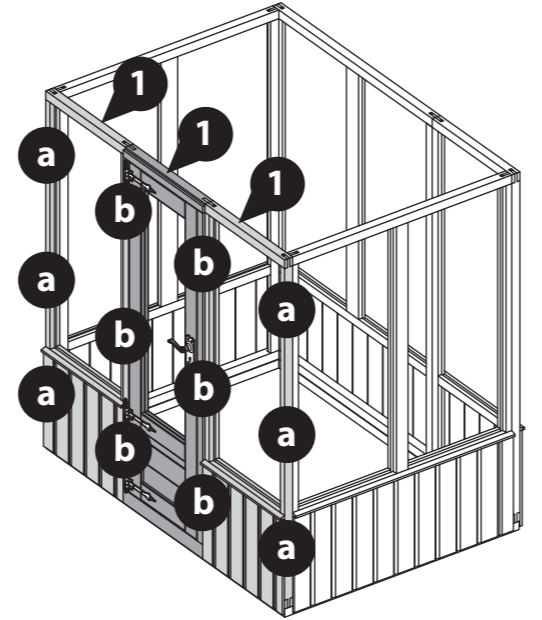

6x6

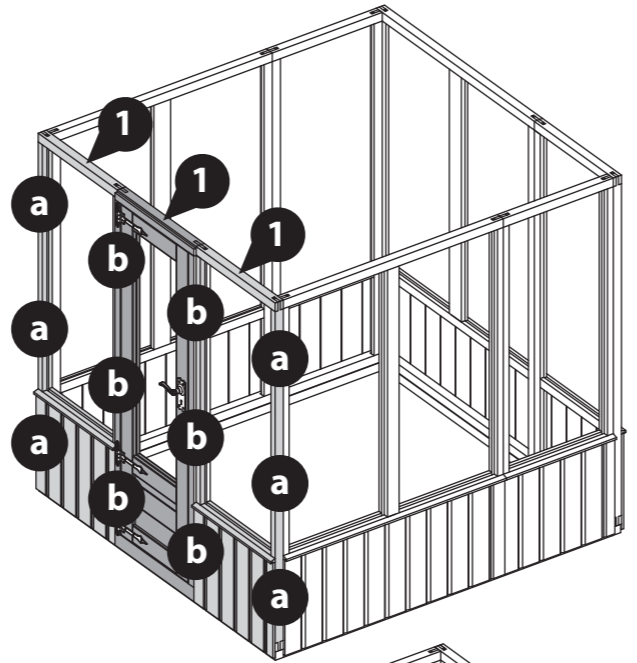

8x6

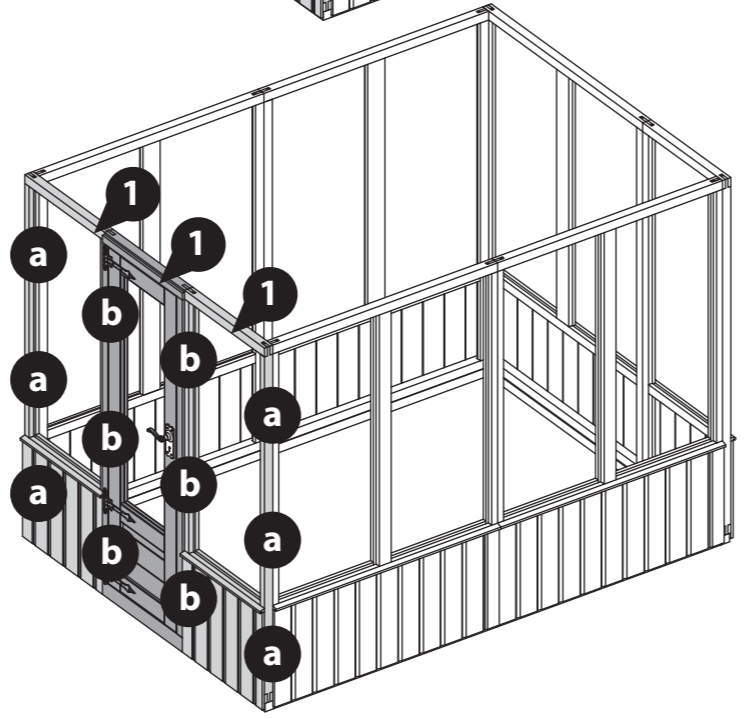

Step 10

Parts Needed

Building	No. 4	50mm screw
4x6	QTY 10	QTY 40
6x6	QTY 12	QTY 48
8x6	QTY 14	QTY 56

Additional Height upgrade only.

If you have not purchased the Additional Height upgrade, then please skip to the next step (Step 11).

a At one end of the building, locate three 2ft Height Extension Panels (No. 4) on top of one of the panels, as shown. Ensure each Extension Panel is flush and level with the wall Panel framing below and to the adjacent Extension Panels.

Secure each Panel in place using 3x50mm screws, screwing down through the Extension Panel framing into the wall panel framing below.

Fix each Extension panel together using 1x50mm screw, screwing through the upright framing into the panel framing behind.

b Continue to Position the 2ft Height Extension Panels (No. 4) around the top of the building. Ensure each is flush to the panel below and the adjacent Extension Panel.

Secure each to the panel below using 3x50mm screws per Panel. Fix together using 1x50mm screw. When fixing at a corner, ensure to screw through the upright framing into the panel behind, as shown.

Please note: the 8x6 'Door on the end' building configuration has been shown for illustrative purposes and may differ from your chosen configuration. However the process of fitting the Height Extension Panels is the same.

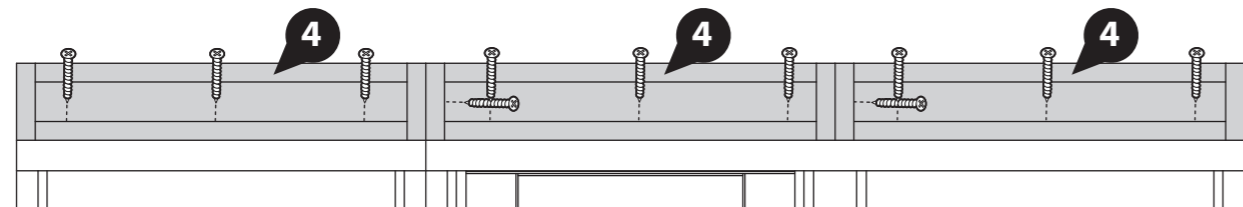

IMPORTANT: Pre-drill before fixing screws.

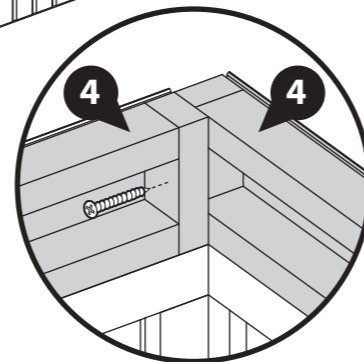
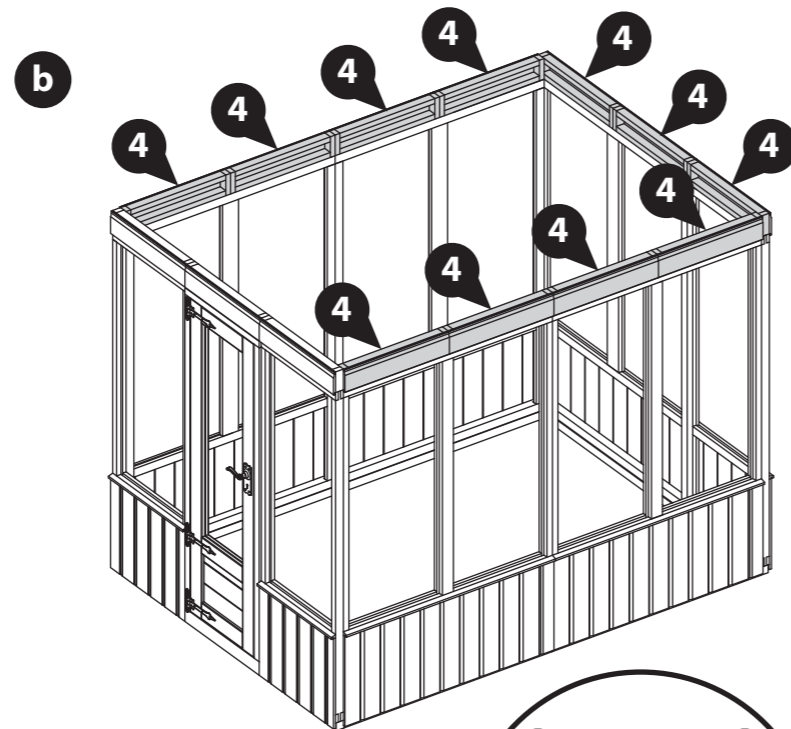
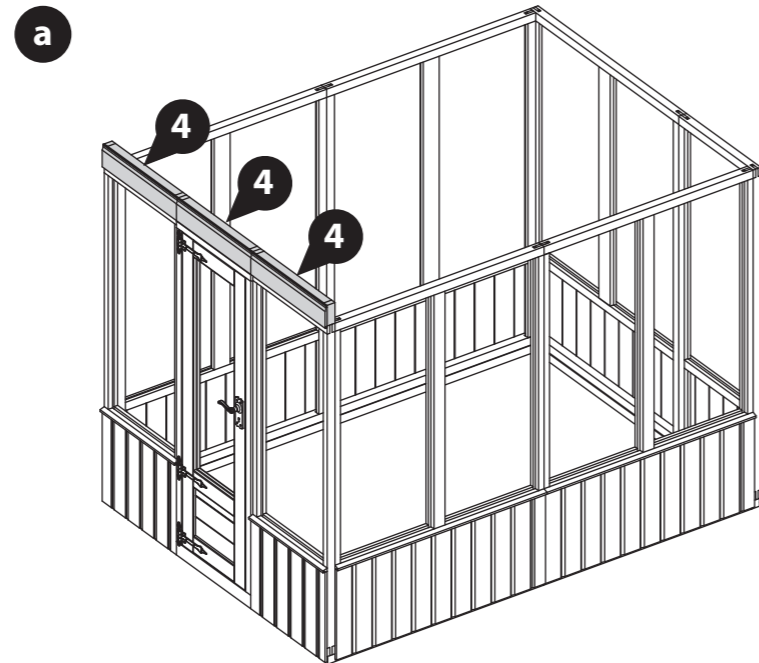

Step 11

Parts Needed

Building	No. 5	60mm screw
All sizes	QTY 2	QTY 8

Locate the Gable Tops (No. 5) on top of the end Panels, ensuring that the framing is flush and level.

Secure in place using 4x60mm screws per Gable, screwing down through the Gable framing into the Panel below.

Height Extension only:

Ensure that the Gable cladding slots into the top cladding on the Height extension panel below, as shown.

Please note: the 8x6 'Door on the end' building configuration has been shown for illustrative purposes and may differ from your chosen configuration. However the process of fitting the Gable Tops is the same.

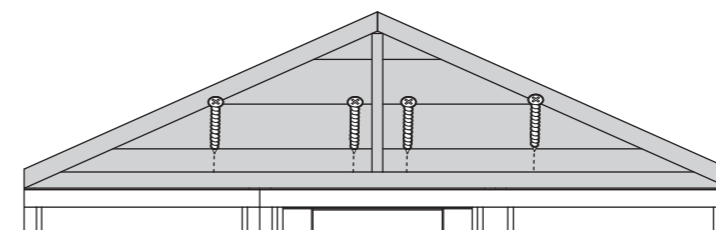

Standard

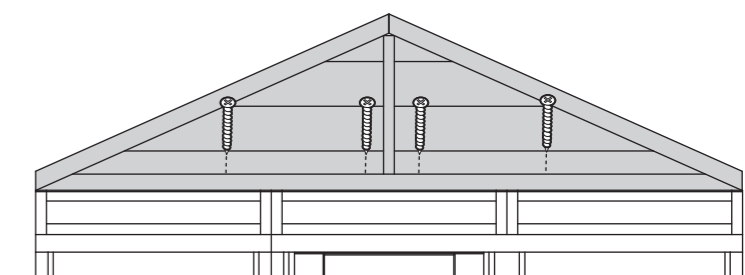

Height Extension

IMPORTANT: Pre-drill before fixing screws.

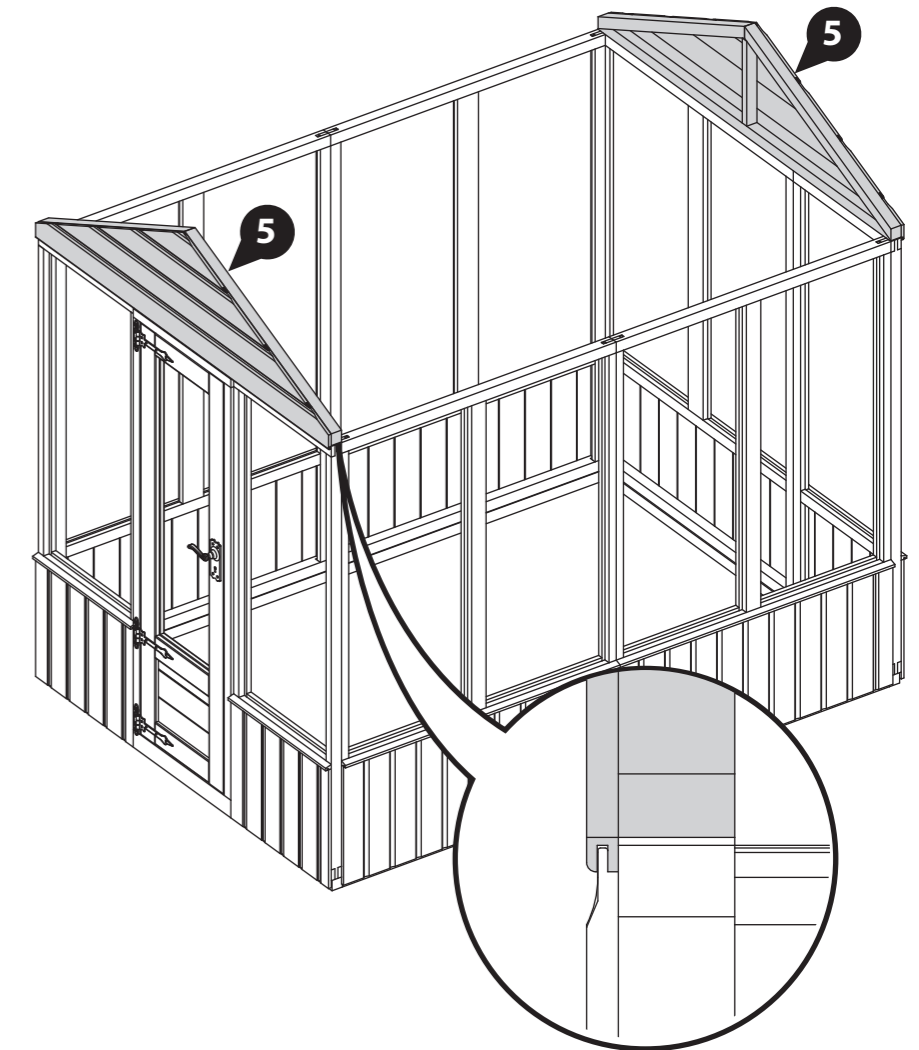

IMPORTANT: Pre-drill before fixing screws.

Step 12 Parts Needed

Building	No. 10	No. 11	No. 22	No. 23	30mm screw
4x6	QTY 1	-	-	QTY 2	QTY 4
6x6	-	QTY 1	-	QTY 2	QTY 4
8x6	QTY 2	-	QTY 1	QTY 2	QTY 14

8x6 only:
Position the Ridge Bars (No. 10) in a row so the ends are flush together and the faces are level. Position one U-channel (No. 22) centrally across each join and secure in place using 10x30mm screws.

All sizes:
Locate one Corner Brace (No. 23) onto either end of the Ridge Bars (No. 10 and/or 11), ensuring they are flush with the ends of the framing, as shown.

Secure in place using 2x30mm screws per Corner Brace (No. 23).

This has constructed your Ridge bar.

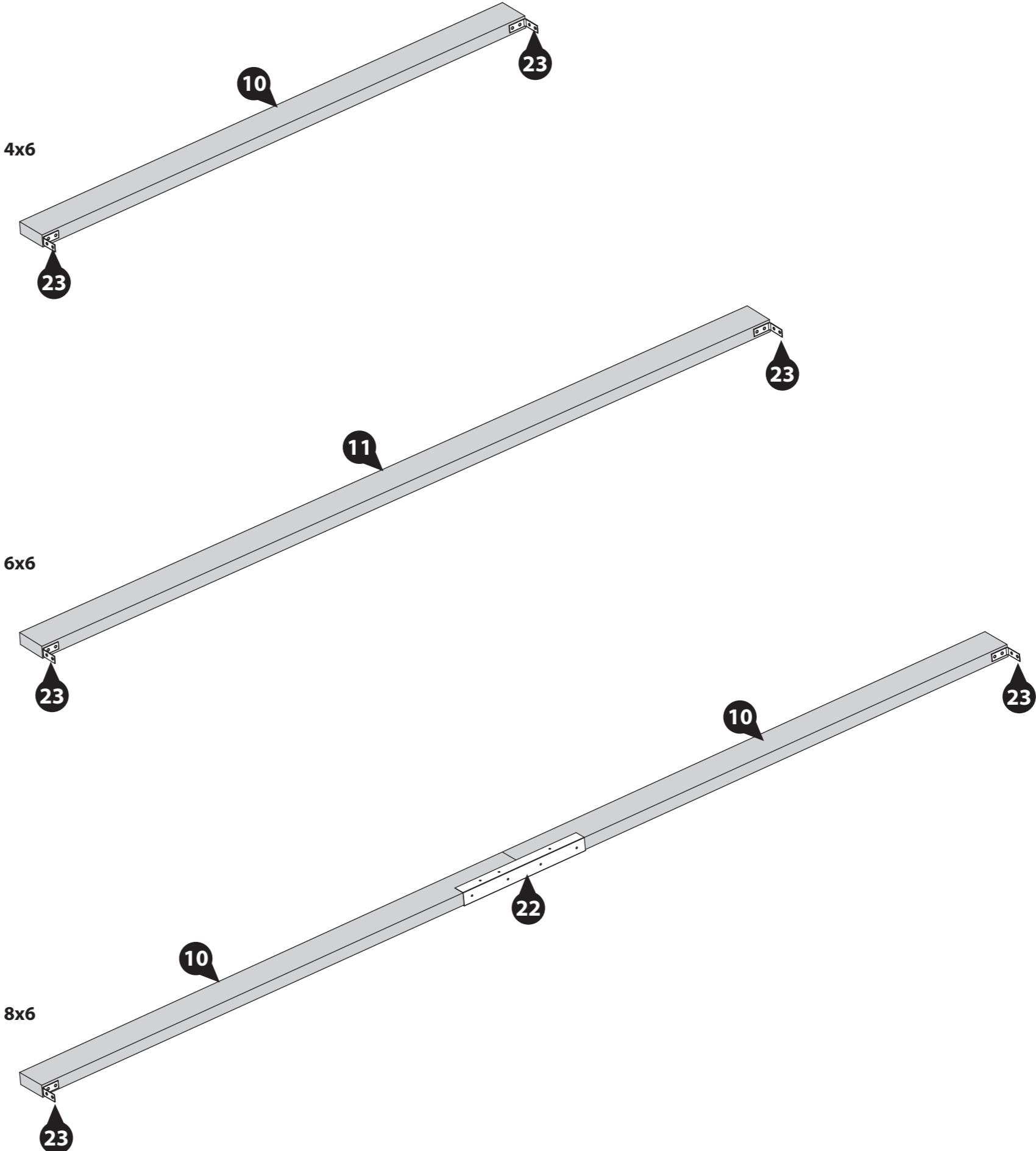
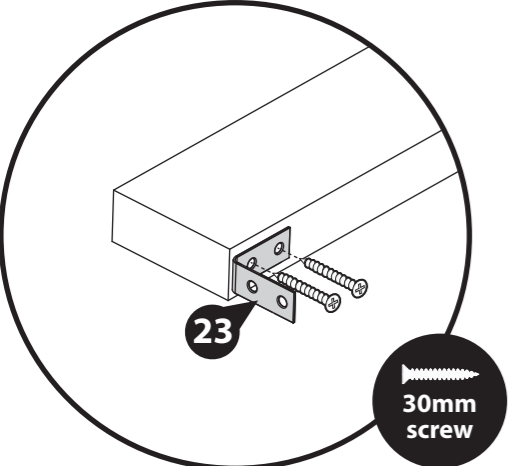
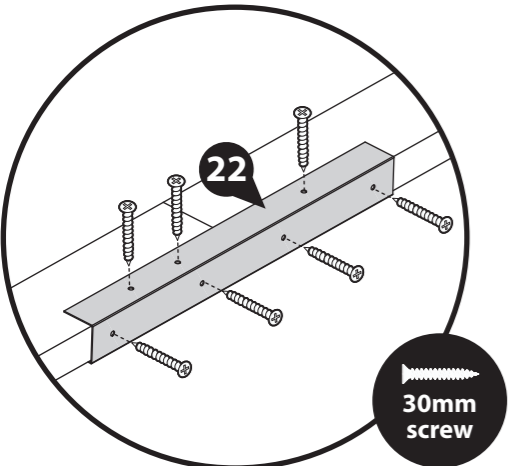

Step 13

Parts Needed

Building

30mm screw

All sizes

QTY 4

IMPORTANT: Pre-drill before fixing screws.

Align the assembled Ridge Bar (No. 10 and/or 11) with the central framing of the Gable Tops, ensuring the sides are flush and the top is level.

(If you have not yet assembled your Ridge Bar, please refer to step 12).

Secure the Corner Braces (No. 23) to the central upright of the Gable Tops using 2x20mm screws per brace.

Please note: the 8x6 'Door on the end' building configuration has been shown for illustrative purposes and may differ from your chosen configuration. However the process of fitting the Ridge Bar is the same.

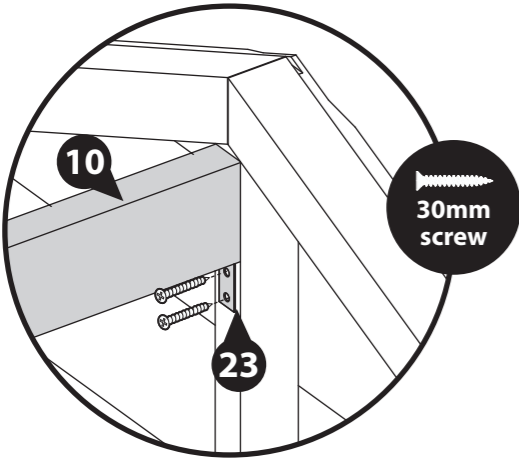
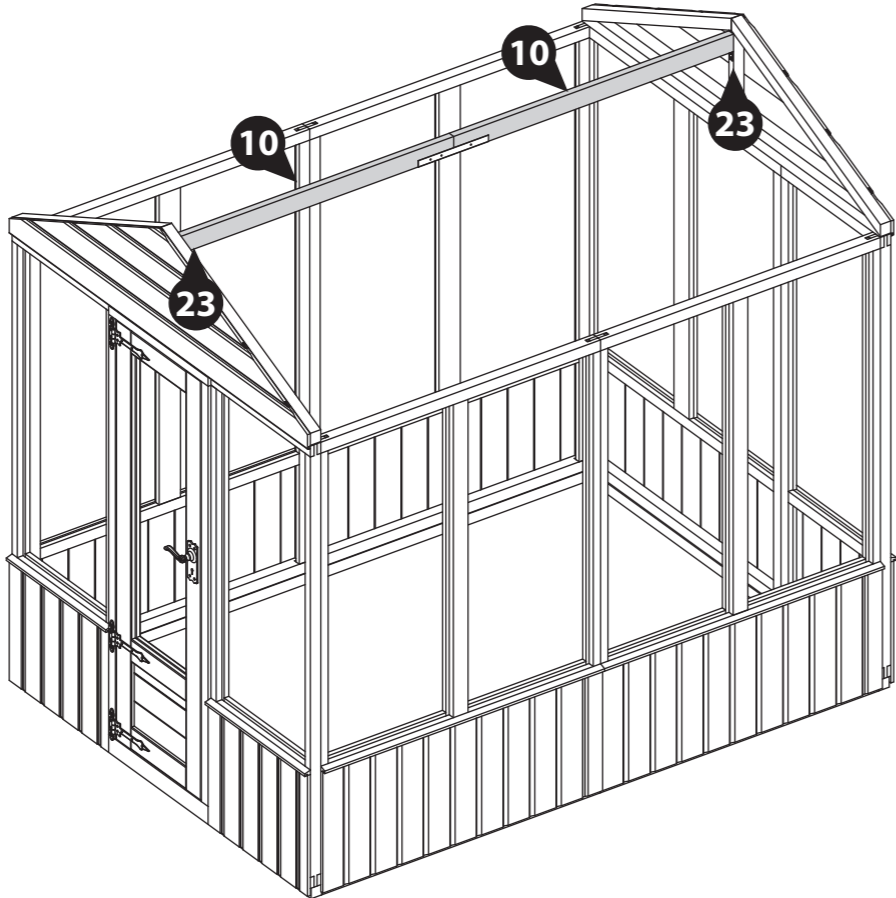

IMPORTANT: Pre-drill before fixing screws.

Step 14

Parts Needed

Building	No. 6	No. 8	No. 12	No. 18	No. 24	No. 25	16mm black screw	30mm black screw	30mm screw	50mm screw
All sizes	QTY 1	QTY 1	QTY 1	QTY 1	QTY 2	QTY 1	QTY 4	QTY 16	QTY 2	QTY 2

- a** Place the 4ft Opening Window Roof (**No. 8**) face up on a flat and level surface.

Position the Window (**No. 6**) and the Window Block (**No. 12**) onto the Roof Panel (**No. 8**) framing, over the open space at the top right of the panel, as shown. The two should be flush and level with the side of the Roof Panel.

Ensuring the Window Block sits just below the top of the Panel and the Window sits on the central framing, secure the Window Block (**No. 12**) in place using 2x50mm screws.

- b** Place the Butt-Hinges (**No. 24**) onto the Window and Window Block. Fix in place using 8x30mm black screws per hinge.

- c** Whilst holding the window shut, flip the Panel over and position the Casement Stay (**No. 25**) centrally inside the Window, so the stay and pins align with the Roof and Window framing, as shown.

***Please ensure to support the window when flipping the panel as the window is not fully secured at this point and WILL open.*

Secure in place using 4x16mm black screws.

- d** With the Panel face down, measure the distance between the roof framing, as shown.

Mark this measurement onto one Cover Trim (**No. 18**) and cut to size.

Position the Cover Trim (**No. 18**) in between the top Roof framing, flush to the top framing. Ensure to cover the join between the Window and Window Block, as shown.

Secure in place using 2x30mm screws, screwing through the trim into the window block behind.

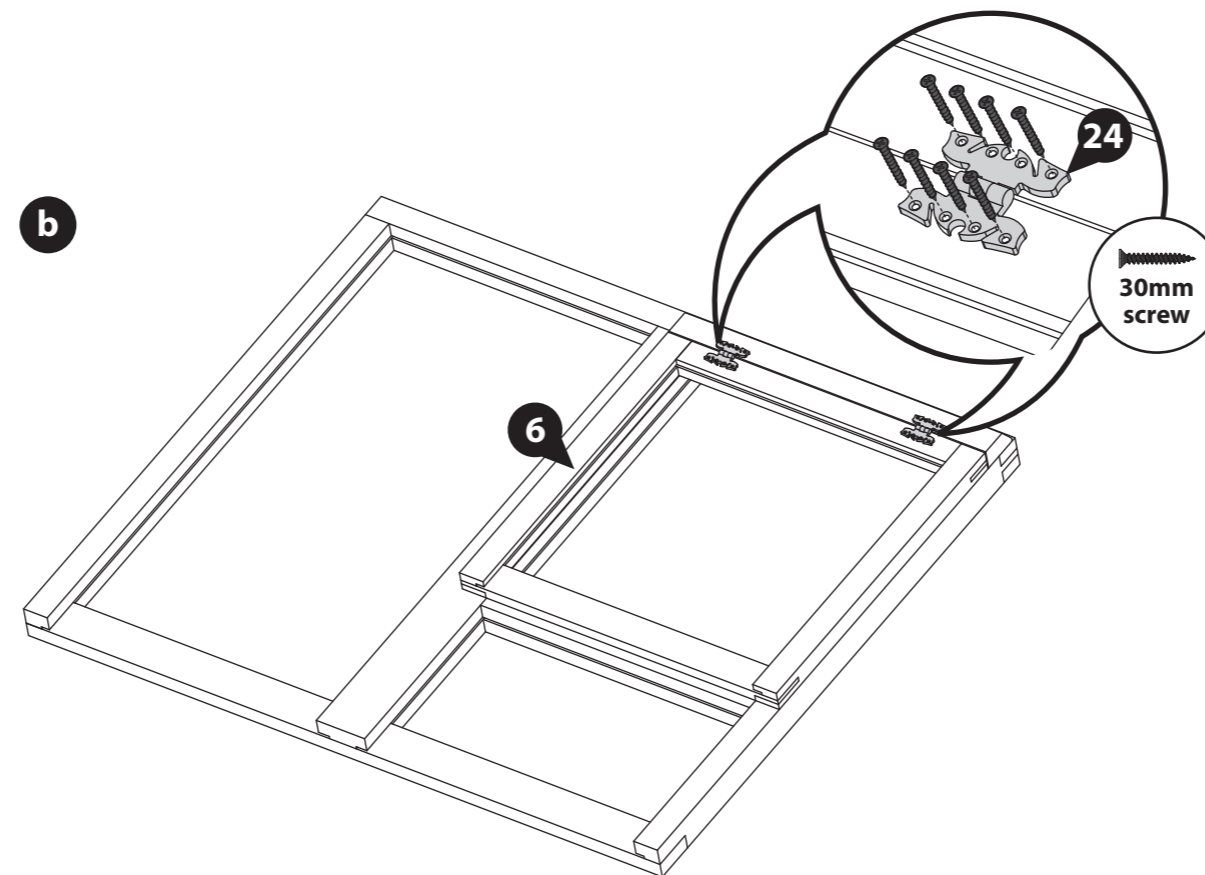
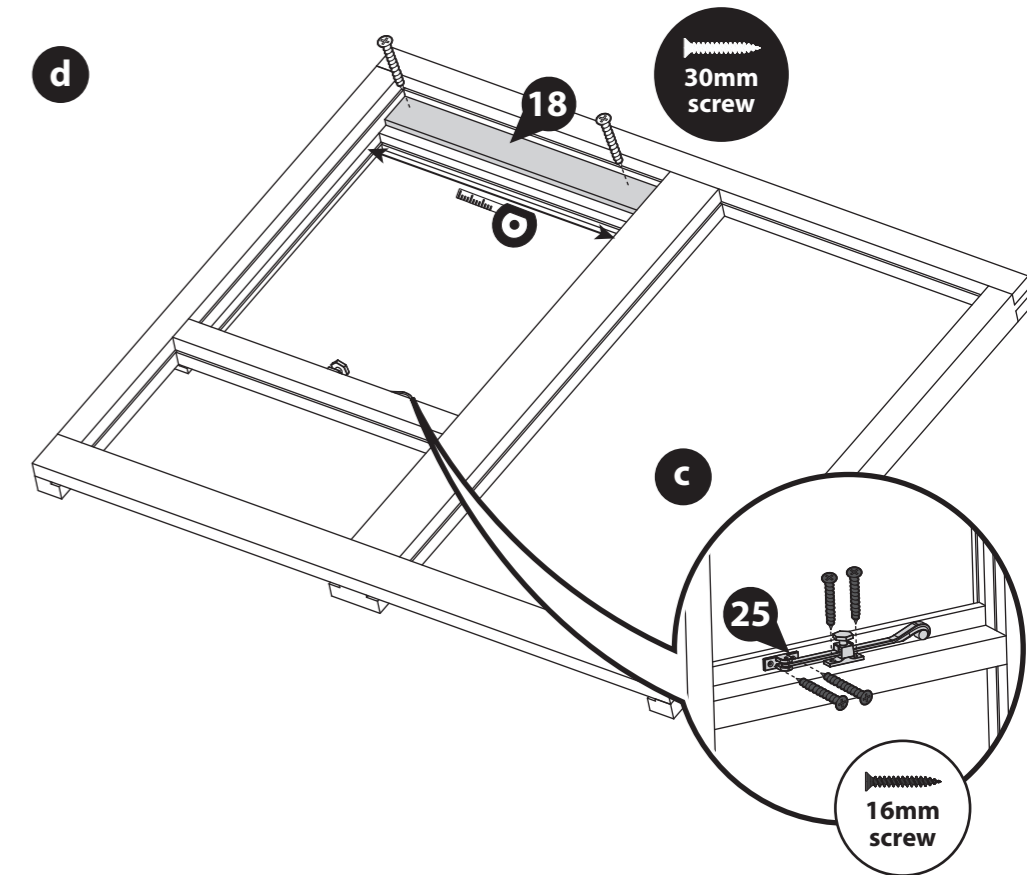
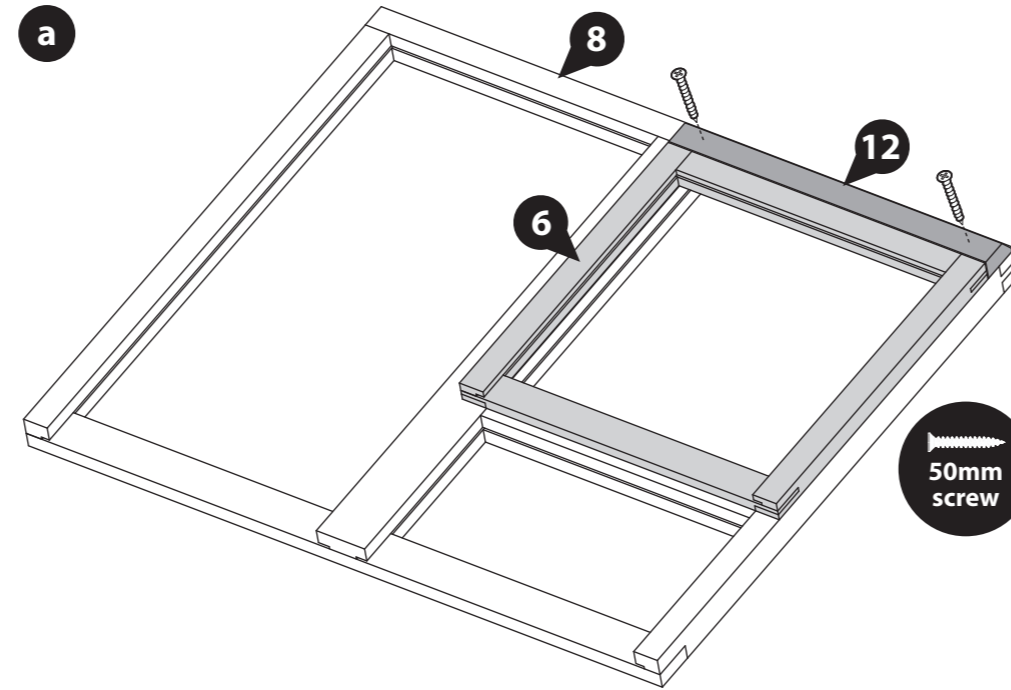

Step 15

Parts Needed

Building	No. 7	No. 8	No. 9	70mm screw
4x6	QTY 1	QTY 1	-	QTY 12
6x6	QTY 1	QTY 1	QTY 2	QTY 20
8x6	QTY 3	QTY 1	-	QTY 20

IMPORTANT

The 4ft Roof Panels (No. 7 & 8) are interchangeable and can be positioned in a variety of different configurations.

Where possible, we strongly advise positioning your opening window panel as central to the greenhouse as possible, as this will allow for the best ventilation.

a At one end of the building, locate two Roof Panels (No. 7, 8 or 9) on either side of the central Ridge Bar, as shown. Ensure the Roofs sit flush to the inside of the Gable Top (No. 5) and the edges are flush at the Apex. The Roof panels should sit approx 12mm above the Gable Top.

*Make sure to position your panels the correct way around. The stepped framing should be at the bottom, as shown.

Fix the Roof Panels to the Gable Top using 3x70mm screws per Roof, screwing through the bottom half of the Roof framing, into the Gable framing behind. Ensure to NOT screw into the Roof channel.

b Continue to Position the Roof panels (No. 7, 8 or 9) onto either side of the building, ensuring they are flush and level. Secure them together as you go using 4x70mm screws per join in an alternating pattern.

c Once all the Roof Panels are positioned, secure them to the Gable Top using 3x70mm screws per Roof.

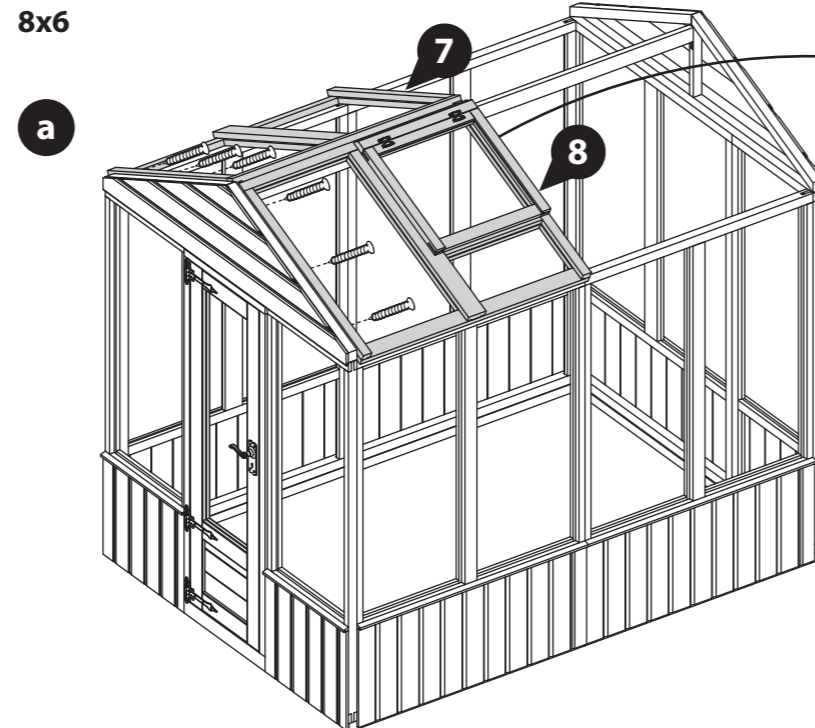

Where possible, we strongly advise positioning your opening window panel as central to the greenhouse as possible.

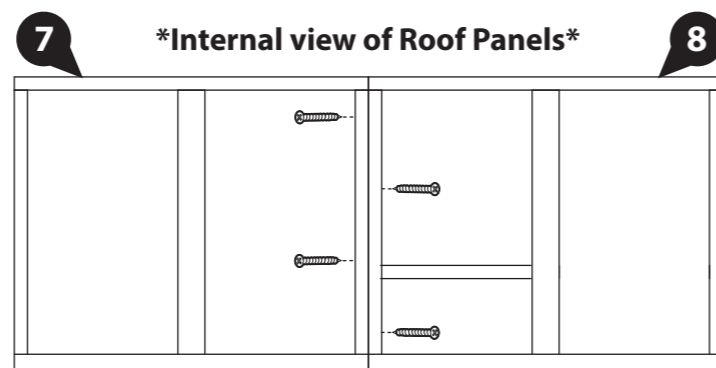
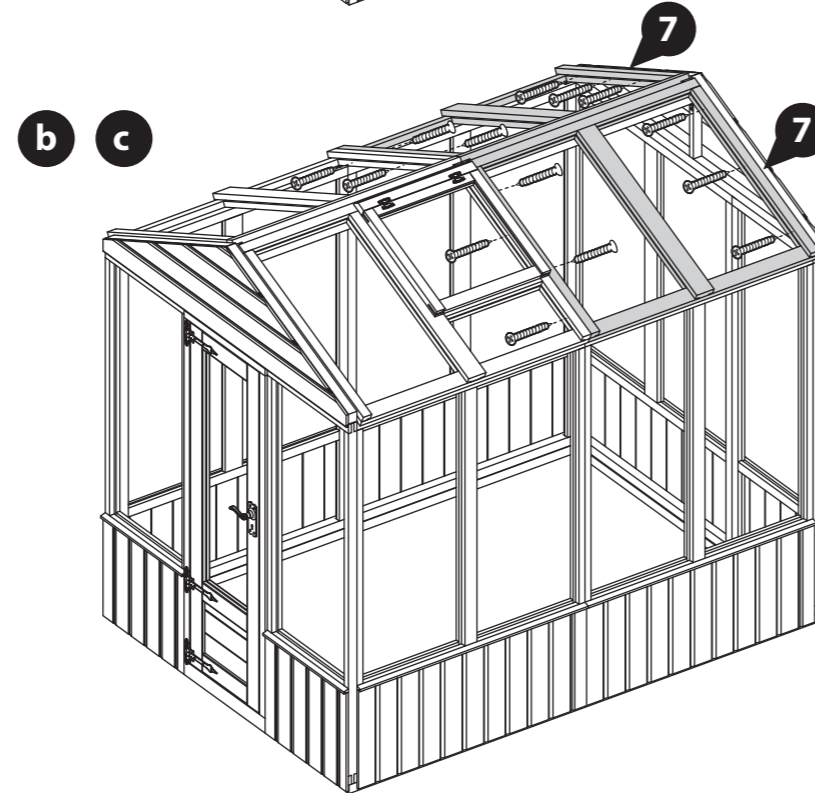
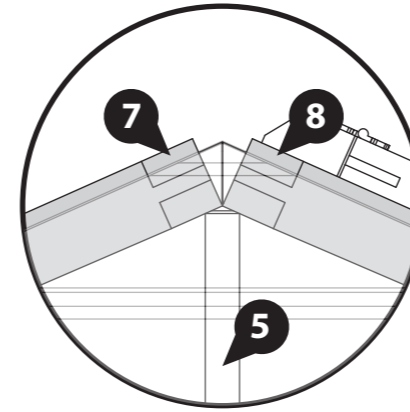

IMPORTANT: Pre-drill before fixing screws.

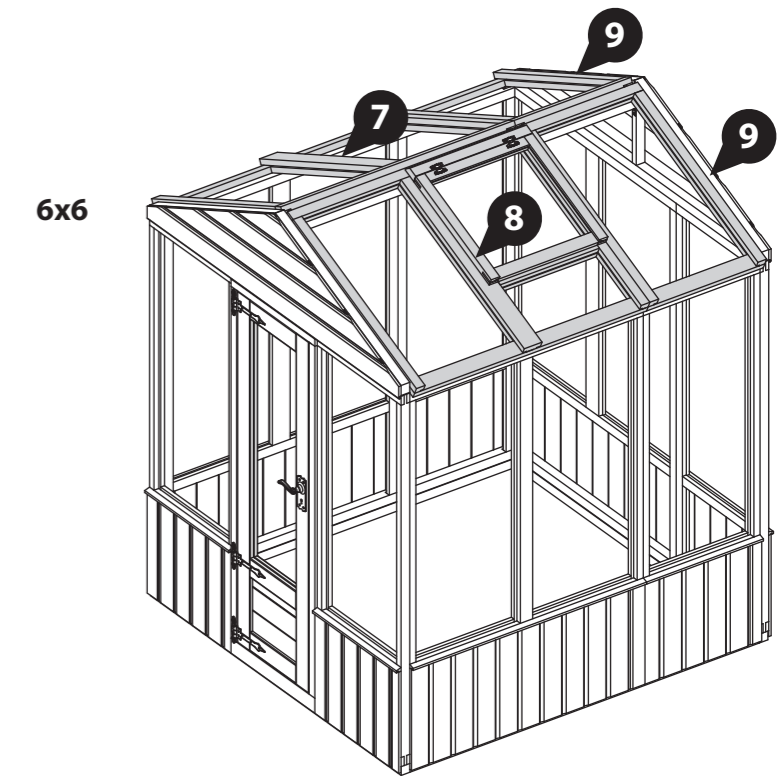
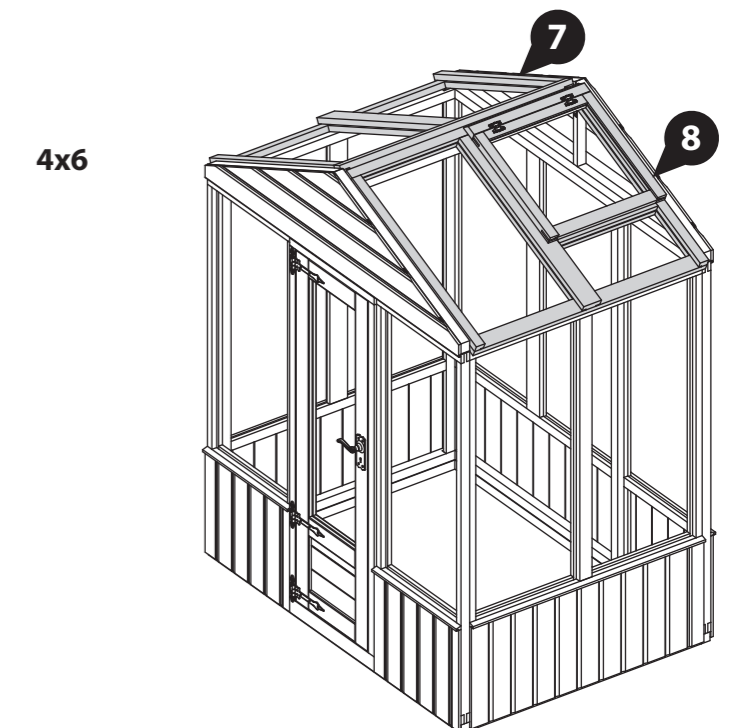

Step 16 Parts Needed

Building	70mm screw
4x6	QTY 4
6x6	QTY 6
8x6	QTY 8

Once the Roof Panels are in place, they can be fixed to the Ridge Bar.

Ensure to check that your Roof panels are level, flush and meet at the apex.

Internally, screw up at an angle through the Ridge Bar (**No. 10 and or 11**) into the Roof Panel (**No. 7, 8 and/ or 9**) framing above using 2x70mm screws per 4ft Roof Panel, and 1x70mm screws per 2ft Roof Panel.

Ensure to stagger the screws to avoid collision.

It is essential that the Ridge Bar and Roof Panels pull together when secured. You may require another person pushing the Ridge Bar up from below when fixing to achieve this.

Please note: the 8x6 'Door on the end' building configuration has been shown for illustrative purposes and may differ from your chosen configuration. However the process of fixing the Ridge Bar is the same.

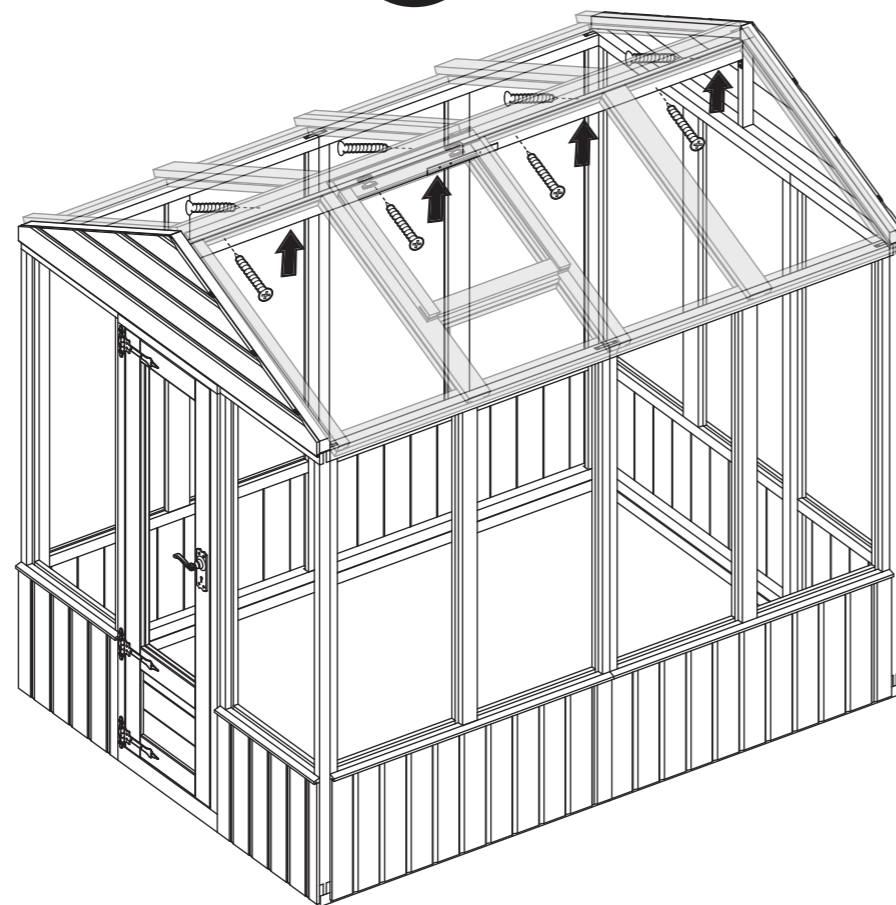
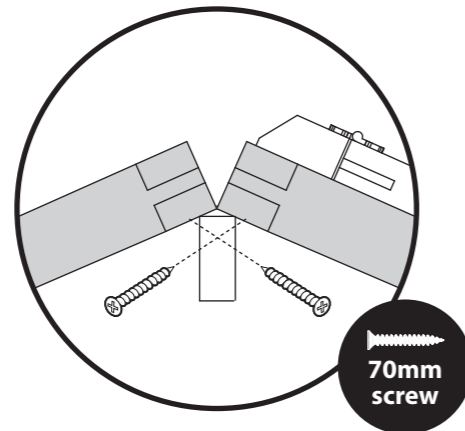

IMPORTANT: Pre-drill before fixing screws.

Step 17 Parts Needed

Building	No. 13	50mm screw
4x6	-	-
6x6	QTY 2	QTY 10
8x6	QTY 2	QTY 10

If you have purchased a 4x6 building, please skip past the Truss assembly steps to Step 20.

On either side of the Ridge bar where the Roofs join, position a Truss Frame (**No. 13**), underneath the Roof Panels (**No. 7, 8 or 9**) so it is central to where they join, as shown.

Ensure to align the angled ends of the Truss Frames (**No. 13**) so they sit flush to the Wall Panel framing and flush to the Ridge Bar, as shown.

Fix the Truss Frame (**No. 13**) in place using 5x50mm screws per frame, screwing up through the Truss Frame (**No. 13**) into the Roof Panels (**No. 7, 8 or 9**).

It is essential that the Truss Frame (**No. 13**) and Roof Panels (**No. 7, 8 or 9**) pull together when secured.

Please note: the 8x6 'Door on the end' building configuration has been shown for illustrative purposes and may differ from your chosen configuration. However the process of fitting the Truss Frame is the same.

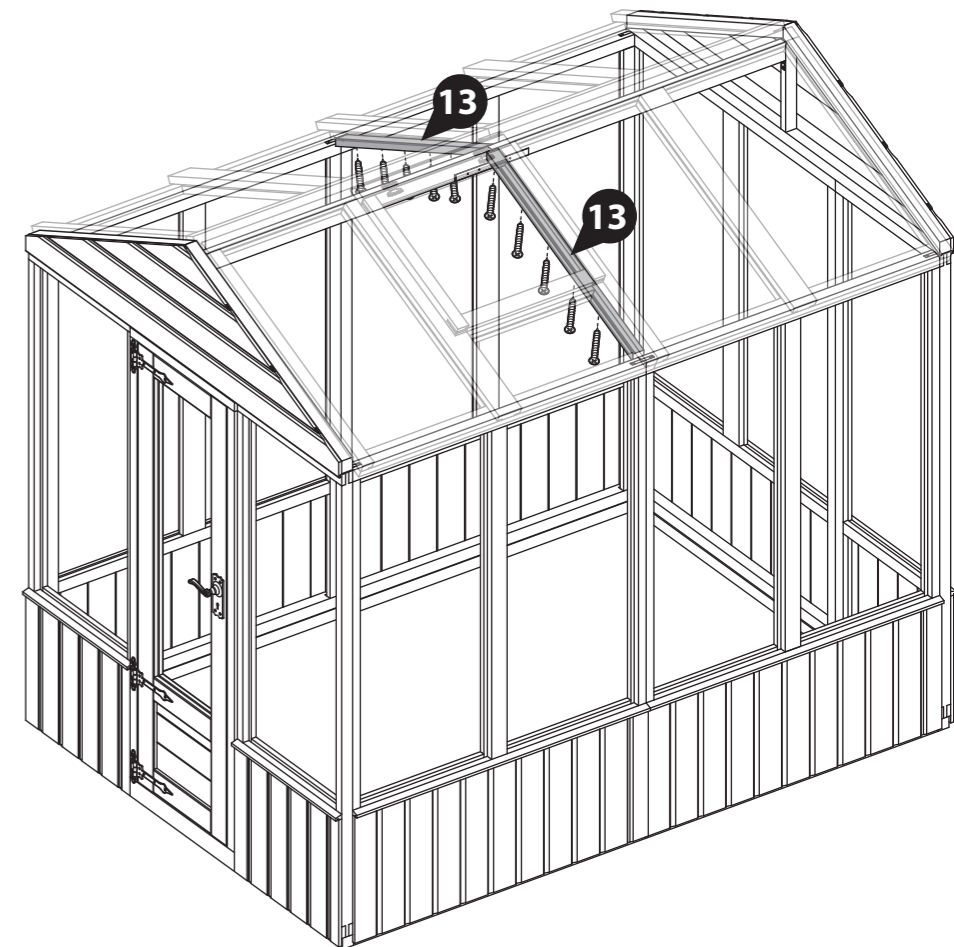

IMPORTANT: Pre-drill before fixing screws.

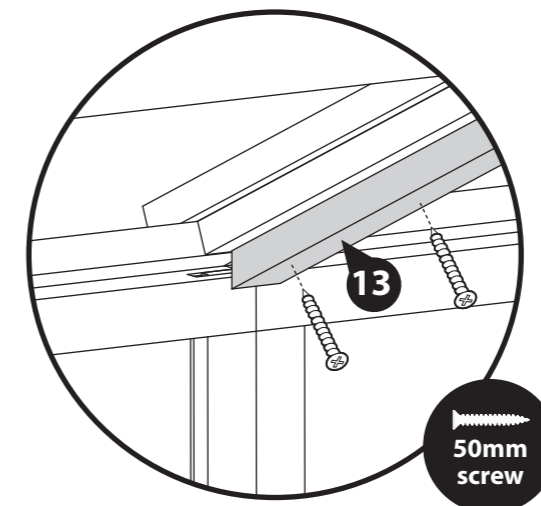

Internal View



IMPORTANT: Pre-drill before fixing screws.

Step 18

Parts Needed

Building	No. 14	50mm screw
4x6	-	-
6x6	QTY 2	QTY 4
8x6	QTY 2	QTY 4

If you have purchased a 4x6 building, please skip past the Truss assembly steps to Step 20.

Place the Truss Block (No. 14) up to the Truss Frame (No. 13) so the angled cut edge is facing upwards, flush to the Truss Frame (No. 13).

Ensure the block is also flush to the Panel uprights behind.

Fix in place using 2x50mm screws through the block into the framing behind, alternating which Panel upright you screw in to, as shown.

Repeat on the opposite side of the building.

Please note: the 8x6 'Door on the end' building configuration has been shown for illustrative purposes and may differ from your chosen configuration. However the process of fitting the truss Block is the same.

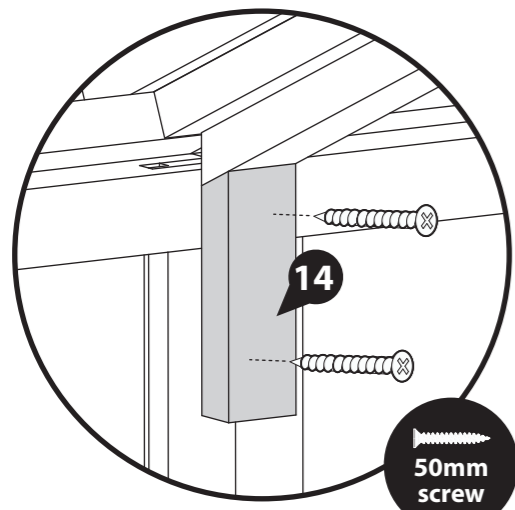

Internal View

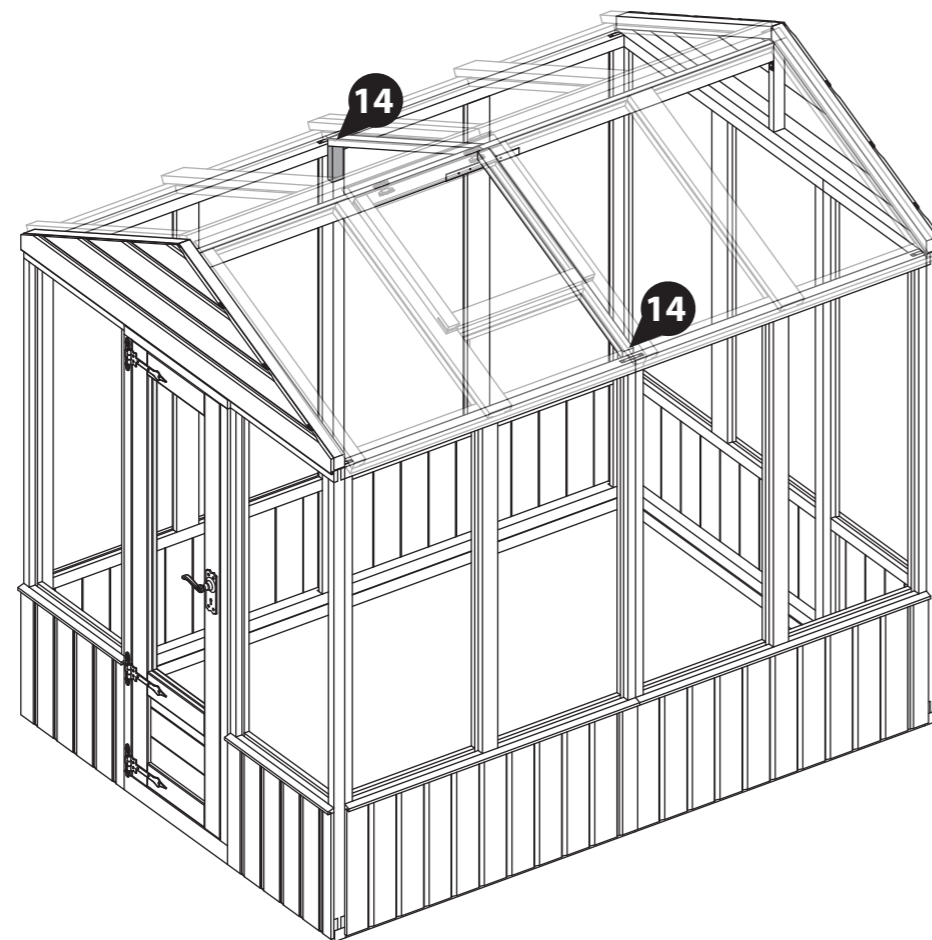

IMPORTANT: Pre-drill before fixing screws.

Step 19

Parts Needed

Building	No. 15	40mm screw
4x6	-	-
6x6	QTY 1	QTY 4
8x6	QTY 1	QTY 4

If you have purchased a 4x6 building, please skip past the Truss assembly steps to Step 20.

Place the Truss Support (No. 15) underneath the two Truss Frames (No. 13) ensuring it sits flush to both.

The Truss Support (No. 15) should sit horizontal - parallel to the floor.

Once in position fix the Truss Support (No. 15) in place using 2x40mm screws at each end of the truss.

Please note: the 8x6 'Door on the end' building configuration has been shown for illustrative purposes and may differ from your chosen configuration. However the process of fitting the Truss Support is the same.

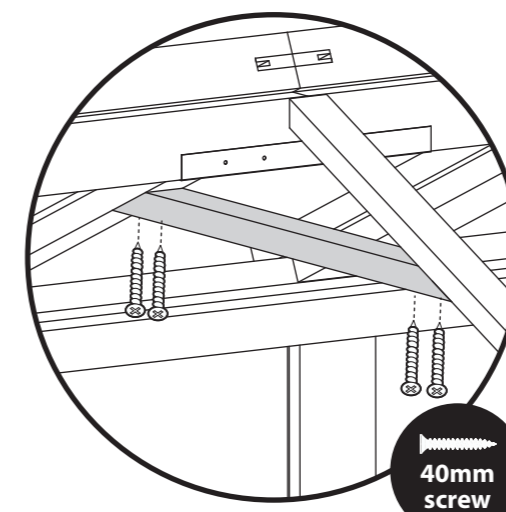

Internal View

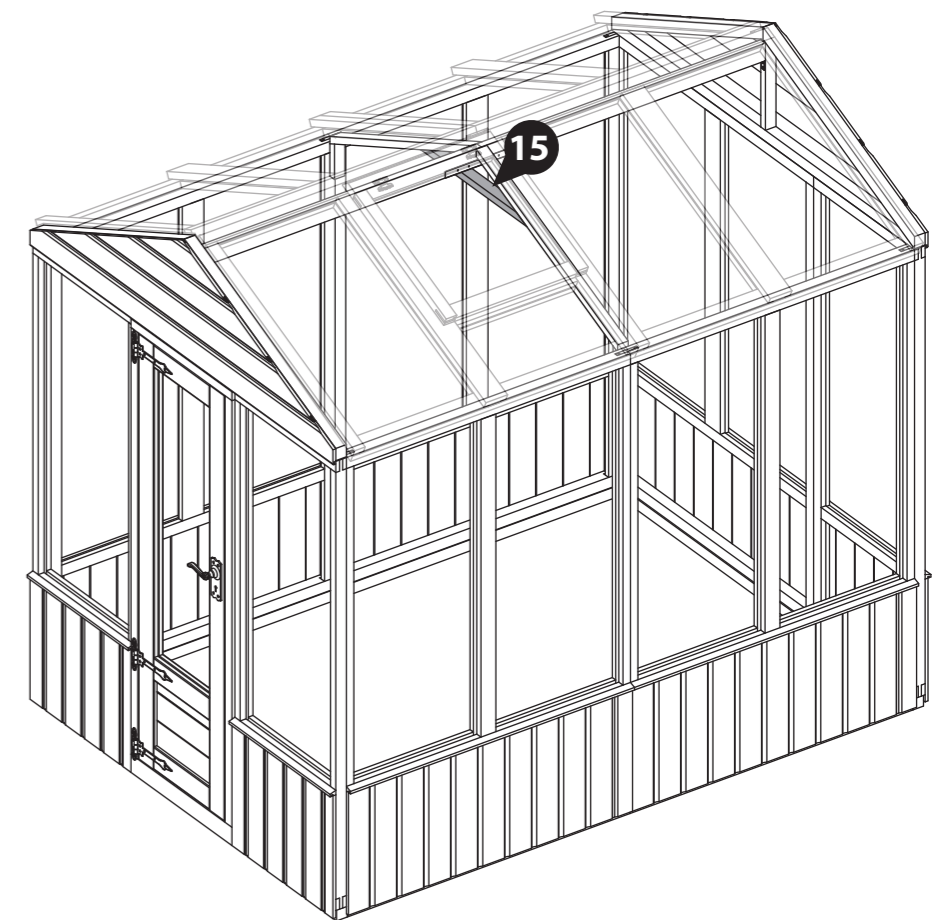

Step 20

Parts Needed

Building	50mm screw
4x6	QTY 8
6x6	QTY 12
8x6	QTY 16

Make sure the building is square by measuring from corner to corner and comparing the measurements. If the measurements are equal, the building is square, if not, adjustments may be required.

Once square, secure the Roofs in place using 50mm screws, screwing down through the Roof framing into the Panel framing below.

Ensure the screws are countersunk to avoid interference when glazing.

Please note: the 8x6 'Door on the end' building configuration has been shown for illustrative purposes and may differ from your chosen configuration. However the process of fixing the Roof is the same.

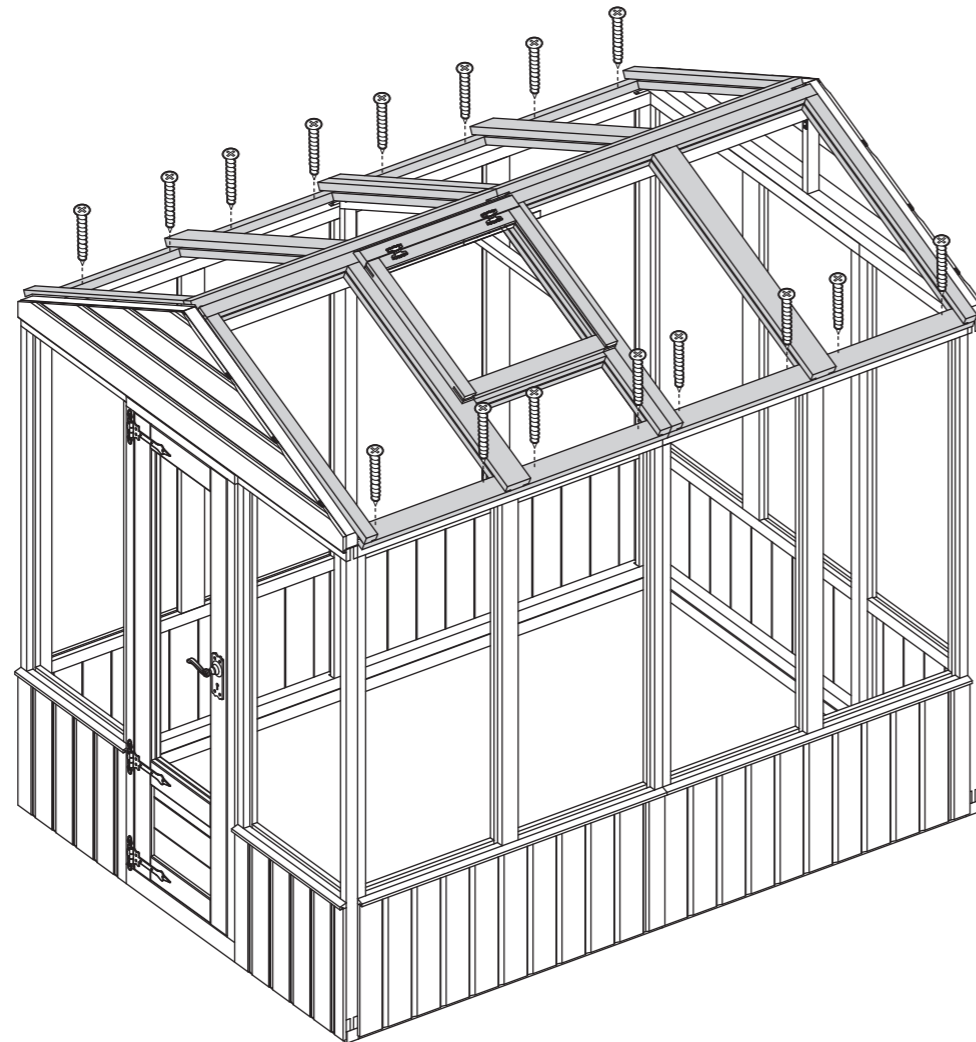

IMPORTANT: Pre-drill before fixing screws.

Step 21

Parts Needed

Building	70mm screw
4x6	QTY 17
6x6	QTY 21
8x6	QTY 23

Once the Roof is fixed, secure the Panels to the base frame using 70mm screws, screwing down through the Panel framing into the base frame below.

Please note: the 8x6 'Door on the end' building configuration has been shown for illustrative purposes and may differ from your chosen configuration. However the process of fixing the Panels is the same.

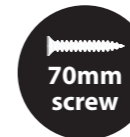
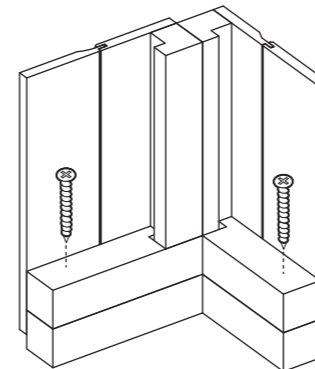

IMPORTANT: Pre-drill before fixing screws.

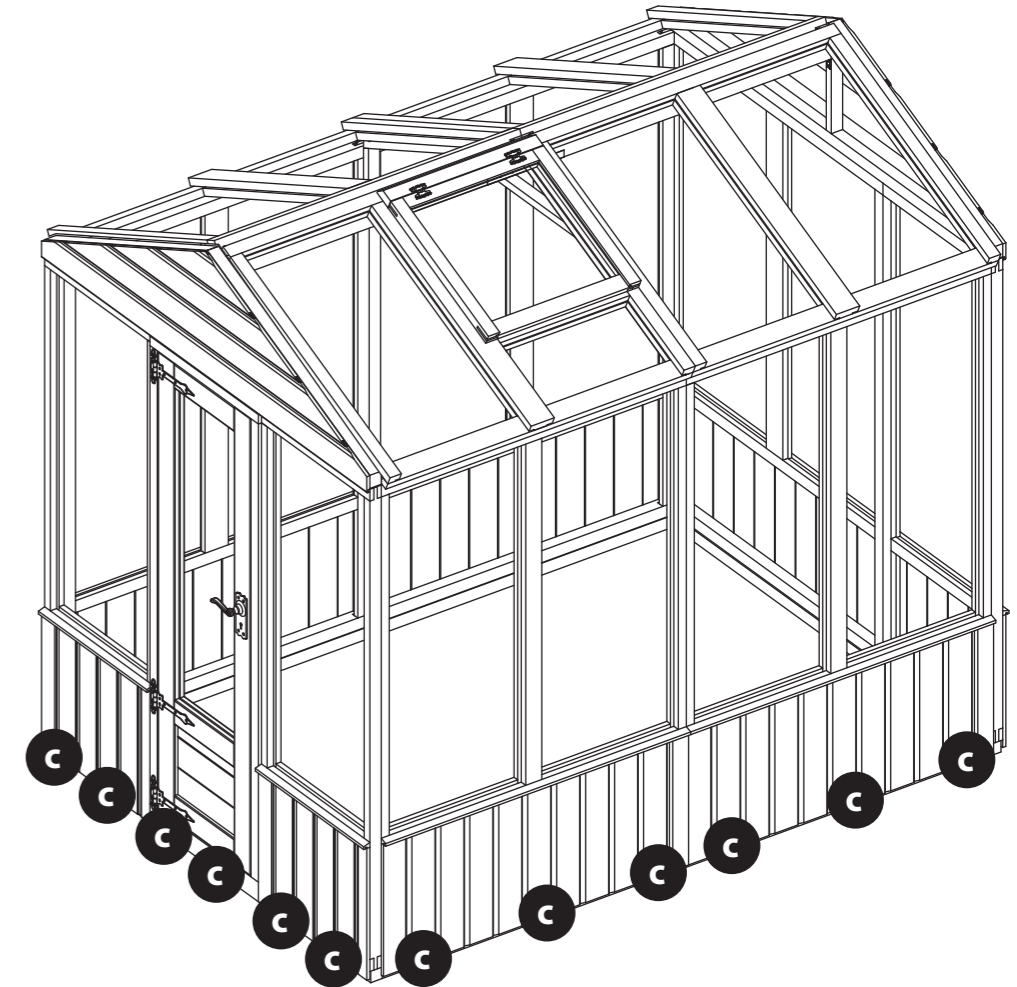

Step 22

Parts Needed

Building	No. 16	No. 17	50mm screw
4x6	-	QTY 1	QTY 4
6x6	QTY 1	-	QTY 4
8x6	-	QTY 2	QTY 8

Position the Roof Supports (**No. 16 and/or 17**) at the top of the Apex, in-between the Roof Panels. Ensure the Supports are flush to the inside of the Gables and the cut outs sits on the top of the Roof Panels, as shown.

Secure in place using 4x50mm screws per roof Support, screwing at an angle through the top of the support into the roof panel behind. Alternate screws to avoid collision.

Please note: the 8x6 'Door on the end' building configuration has been shown for illustrative purposes and may differ from your chosen configuration. However the process of fitting the Roof Support is the same.



IMPORTANT: Pre-drill before fixing screws.

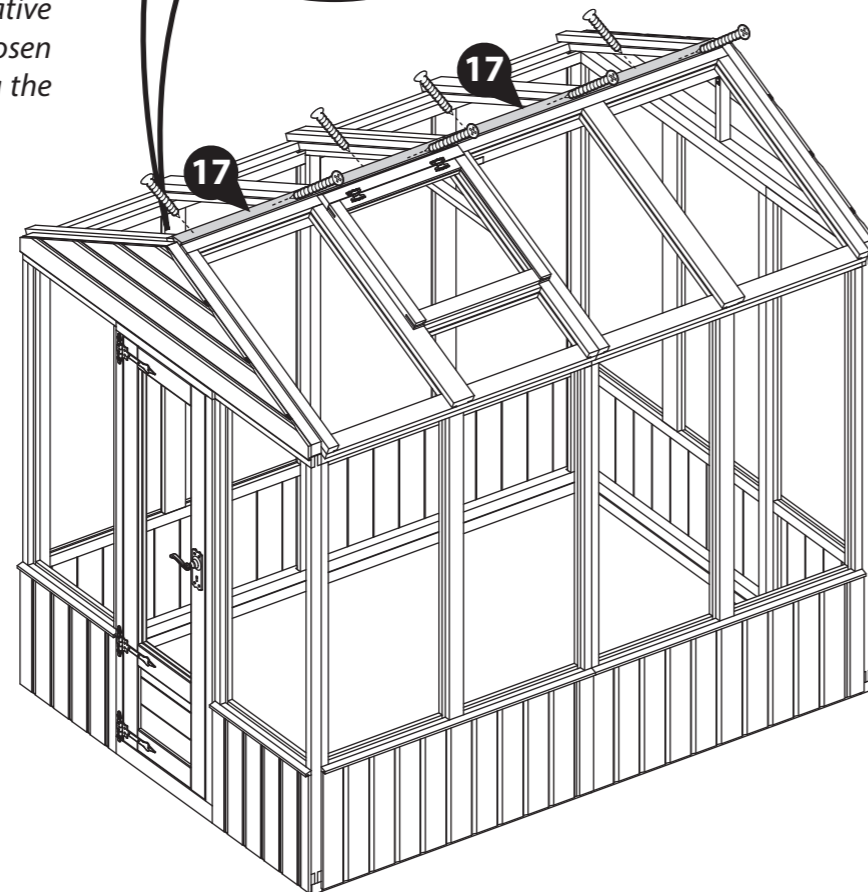
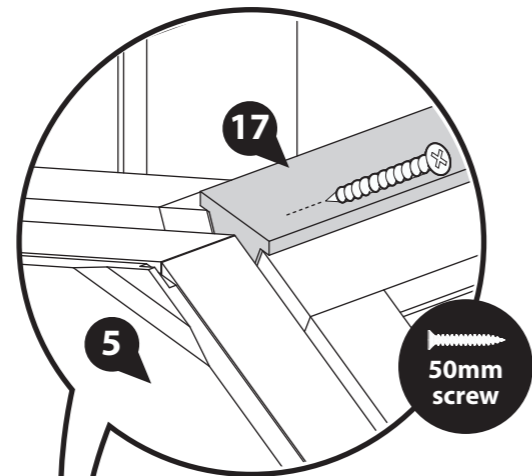

Step 23

Parts Needed

Building	No. 18	30mm screw
4x6	QTY 5	QTY 18
6x6	QTY 7	QTY 30
8x6	QTY 7	QTY 30

Please note: You have been supplied with a total of 12 Cover Trims (No. 18) however you may not need to use them all.

a At each corner and Panel join, use a tape measure to measure the distance the Cover Trim needs to fill e.g. from the bottom of the Panel to the top of the Panel or from the top of the cill to the top of the panel.

Mark the measurements onto the Cover Trims (**No. 18**) and cut to size if required.

Please note: For the panel joins, one Cover Trim can be cut to create both the top and bottom. Ensure to use all of one Cover Trim where possible before cutting a new one. Do not dispose of off-cuts until the building is fully constructed as they may be needed in another step.

b Locate the Cover Trims (**No. 18**), over each Panel join and corner, ensuring they sit centrally over the joins and flush to the Panel cladding at the corners.

Secure in place using 3x30mm screws per Cover Trim, alternating fixing into each Panel when over a join.

Please note: the 8x6 'Door on the end' building configuration has been shown for illustrative purposes and may differ from your chosen configuration. However the process of fitting the Cover Trims is the same.



IMPORTANT: Pre-drill before fixing screws.

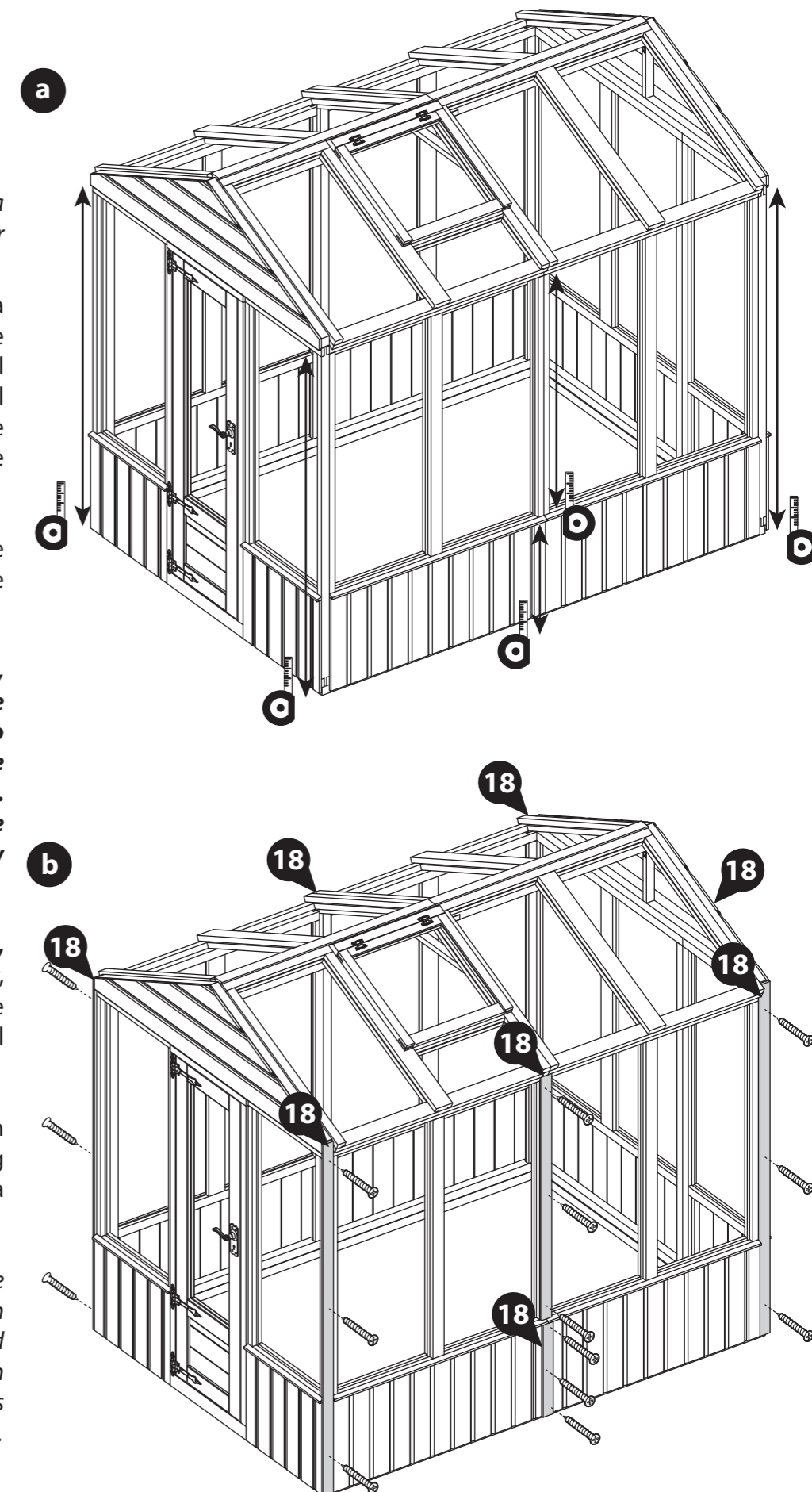

Step 24 Parts Needed

Building	No. 18	30mm screw
4x6	QTY 1	QTY 12
6x6	QTY 1	QTY 16
8x6	QTY 1	QTY 20

Additional Height upgrade only.
 If you have not purchased the Additional Height upgrade, then please skip to the next step (Step 25).

a Where each 2ft Height Extension Panel (No. 4) joins to the next, use a tape measure to measure from the top of the panel to the bottom, as shown.

Mark the measurements onto the Cover Trims (No. 18) and cut to size if required.

Please note: Ensure to use all of one Cover Trim where possible before cutting a new one. You may have a suitable size remaining from the previous step. Do not dispose of off-cuts until the building is fully constructed as they may be needed in another step.

b Locate the Cover Trims (No. 18), over each Panel join, ensuring they sit centrally over the joins.

Secure in place using 2x30mm screws per Trim, alternating fixing into each Panel.

Please note: the 8x6 'Door on the end' building configuration has been shown for illustrative purposes and may differ from your chosen configuration. However the process of fitting the Cover Trims is the same.



IMPORTANT: Pre-drill before fixing screws.

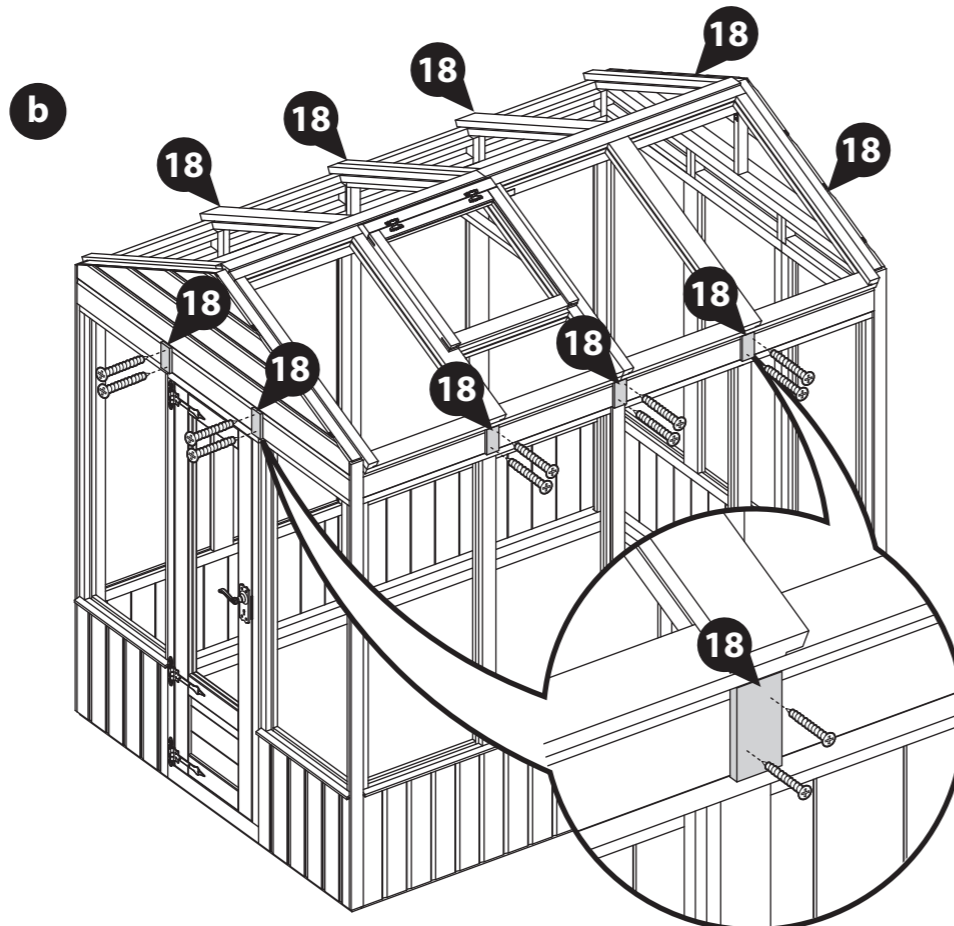
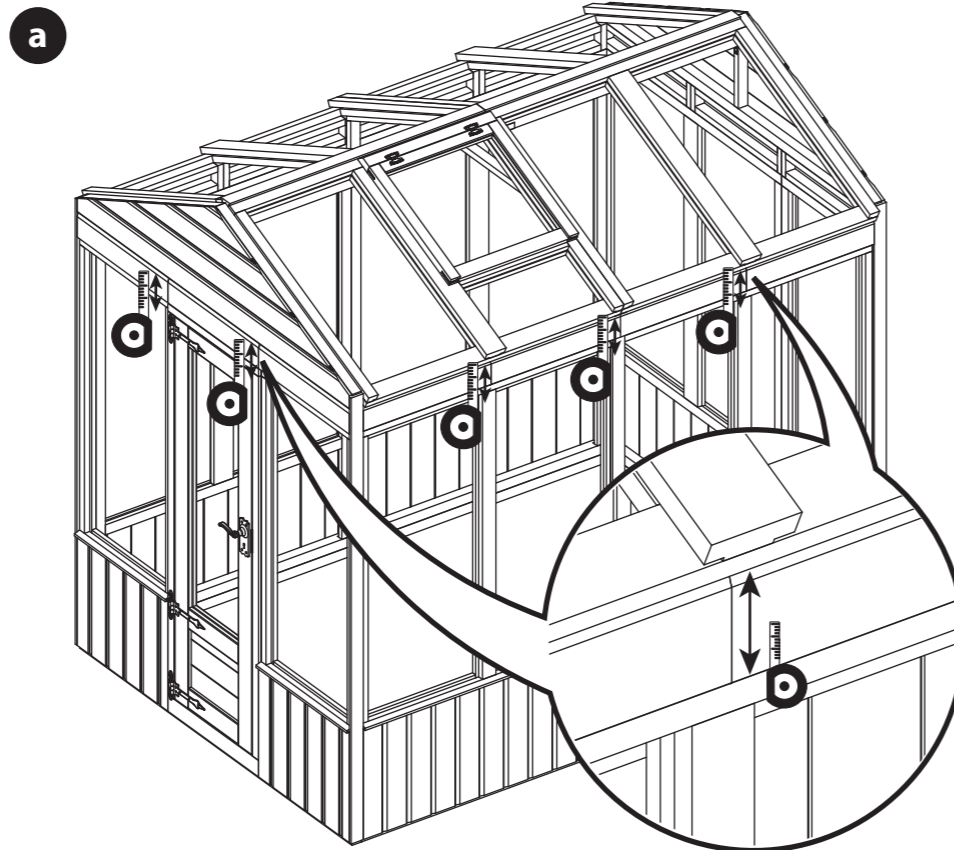

Step 25 Parts Needed

Building	No. 18	30mm screw
All sizes	QTY 2	QTY 12

a At each end of the building, use a tape measure to measure the distance from the top of the apex to the bottom of the Roof Panel on either side, as shown.

Mark the measurements onto the Cover Trims (No. 18) and cut to size if required.

Please note: One Cover Trim can be cut to create both sizes for one Gable end. Ensure to use all of one Cover Trim where possible before cutting a new one. Do not dispose of off-cuts until the building is fully constructed as they may be needed in another step.

b Locate the Cover Trims (No. 18), over the exposed framing on each Gable, ensuring they sit flush to the cladding and meet at the apex, as shown.

Secure in place using 3x30mm screws per Trim.

Please note: the 8x6 'Door on the end' building configuration has been shown for illustrative purposes and may differ from your chosen configuration. However the process of fitting the Cover Trims is the same.



IMPORTANT: Pre-drill before fixing screws.

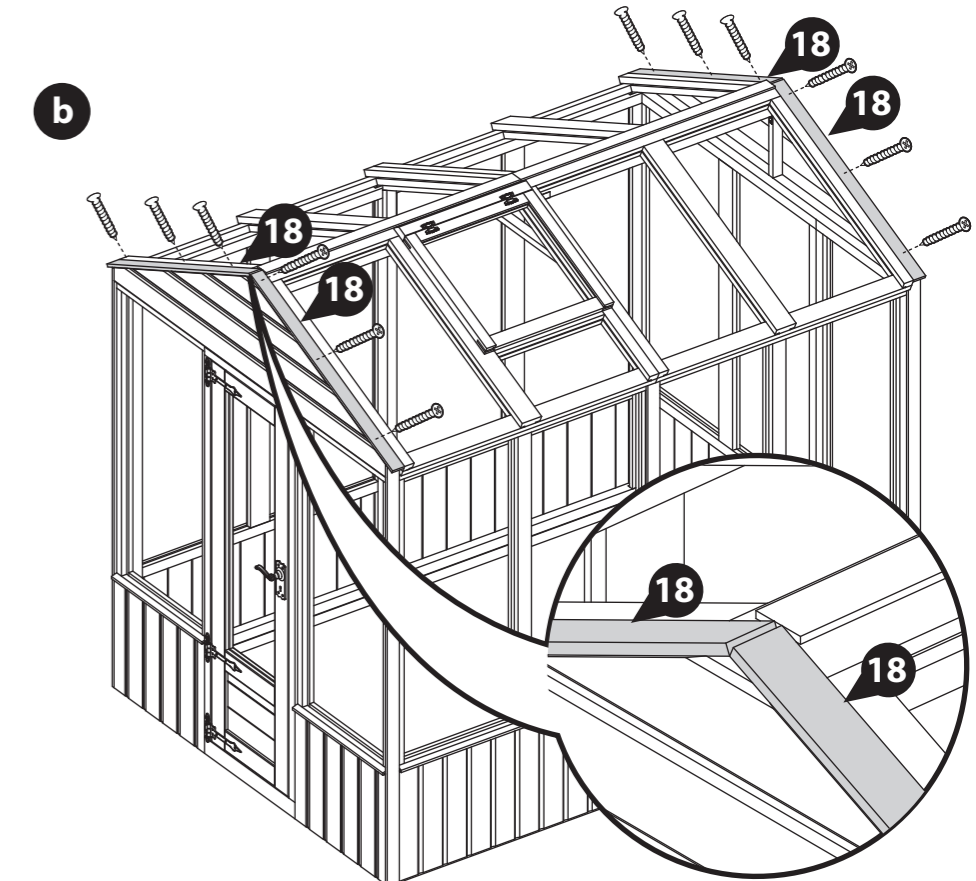
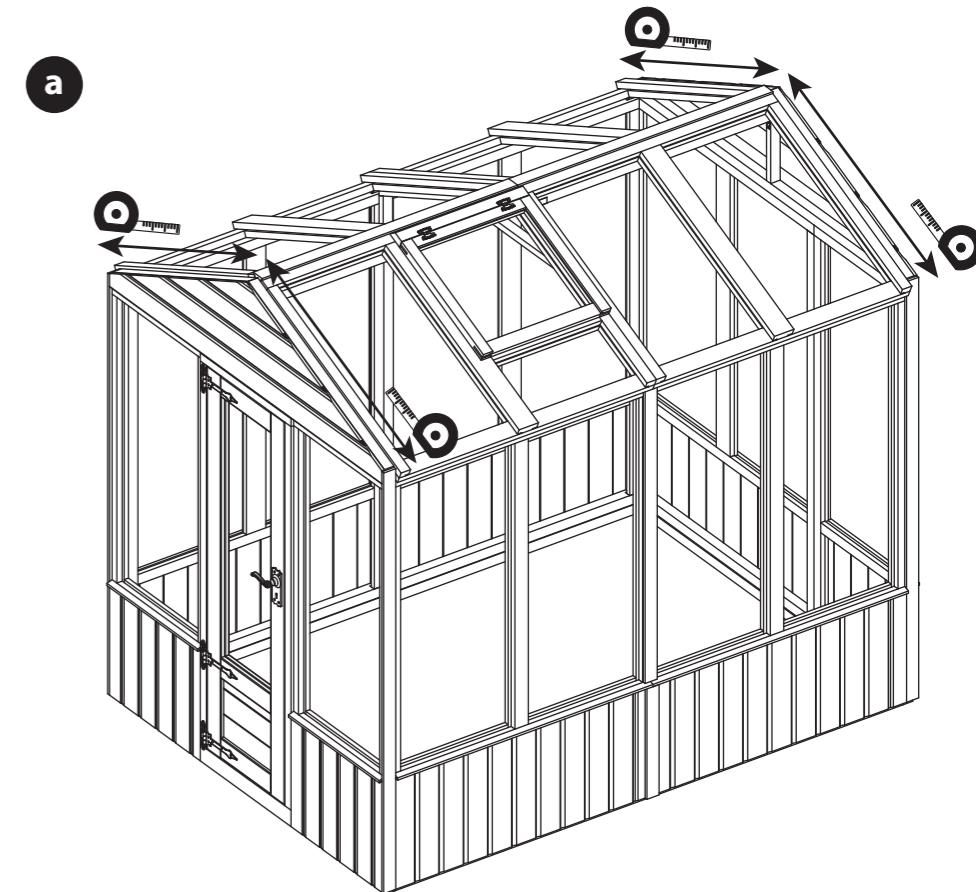

Step 26 Parts Needed

Building	No. 19	30mm screw
All sizes	QTY 2	QTY 12

a At each end of the building, use a tape measure to measure the distance from the side of the Roof Support (**No. 16 and/or 17**) to the bottom of the Roof Panel on either side, as shown.

Mark the measurements onto the Roof Trims (**No. 19**) and cut to size.

Please note: One Roof Trim can be cut to create both sizes for one Gable end. Ensure to use all of one Roof Trim where possible before cutting a new one.

b Locate the Roof Trims (**No. 19**), over the previously fitted Cover Trim and Roof Panel framing. Ensure they sit flush to the Gable cladding, as shown.

Secure in place using 3x30mm screws per Roof Trim, ensuring to stagger the screws to avoid them colliding with the ones below.

4x6 only: Measure and cut a notch out of the Roof Trim next to the window to ensure a neat finish, as shown in the close up illustration below.

Please note: the 8x6 'Door on the end' building configuration has been shown for illustrative purposes and may differ from your chosen configuration. However the process of fitting the Roof Trims is the same.



4x6 only

*Cut to fit

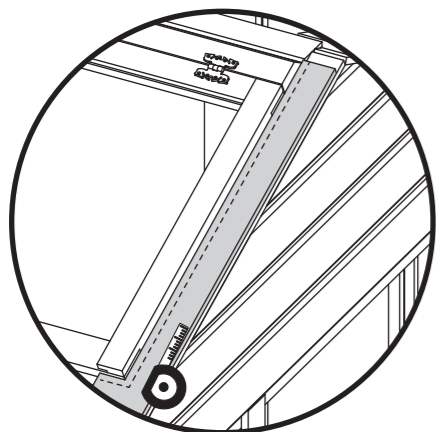

IMPORTANT: Pre-drill before fixing screws.

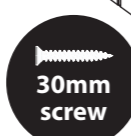
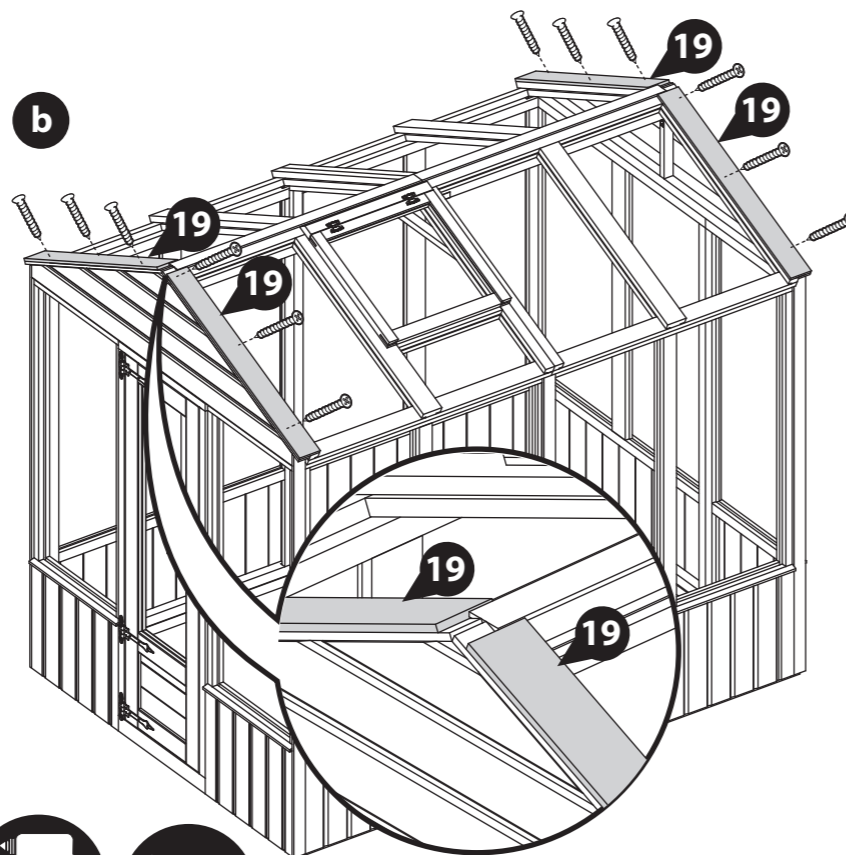
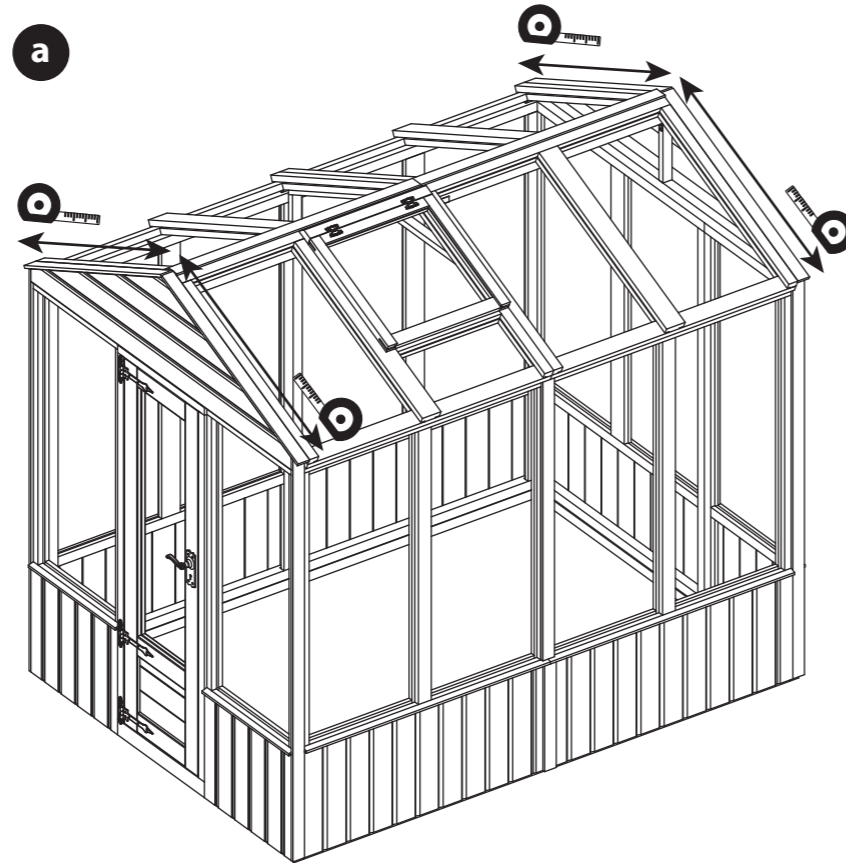

Step 27 Parts Needed

Building	No. 21	30mm screw
4x6	QTY 1	QTY 3
6x6	QTY 1	QTY 3
8x6	QTY 2	QTY 6

a Measure the distance from the front of the building to the back, as shown.

b Lay the Roof Covers (**No. 21**) out end-to-end so they are flush and level. Mark the total measurement across them, as shown.

Use a saw to remove the excess material.

c Position the cut down Roof Covers (**No. 21**) centrally on top of the Roof Support framing (**No. 16 and/or 17**). Ensure the Roof Cover finishes flush with the Roof Trims (**No. 19**) at either end.

Secure in place using 30mm screws, ensuring to stagger the screws to avoid them colliding with the ones below.

Please note: the 8x6 'Door on the end' building configuration has been shown for illustrative purposes and may differ from your chosen configuration. However the process of fitting the Roof Cover is the same.

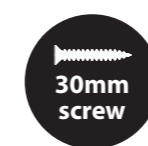

IMPORTANT: Pre-drill before fixing screws.

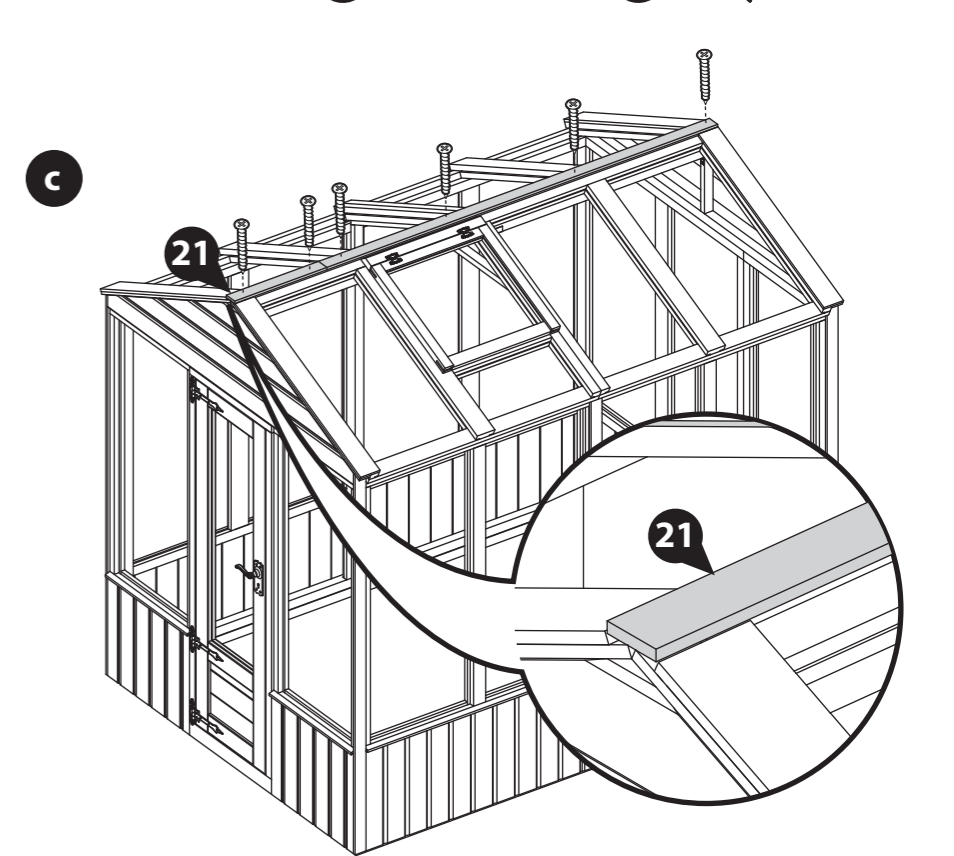
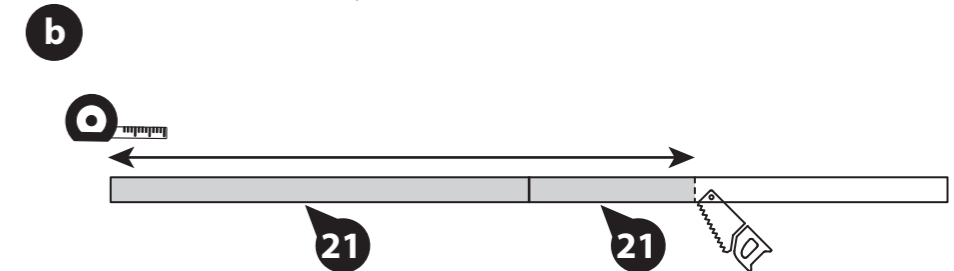
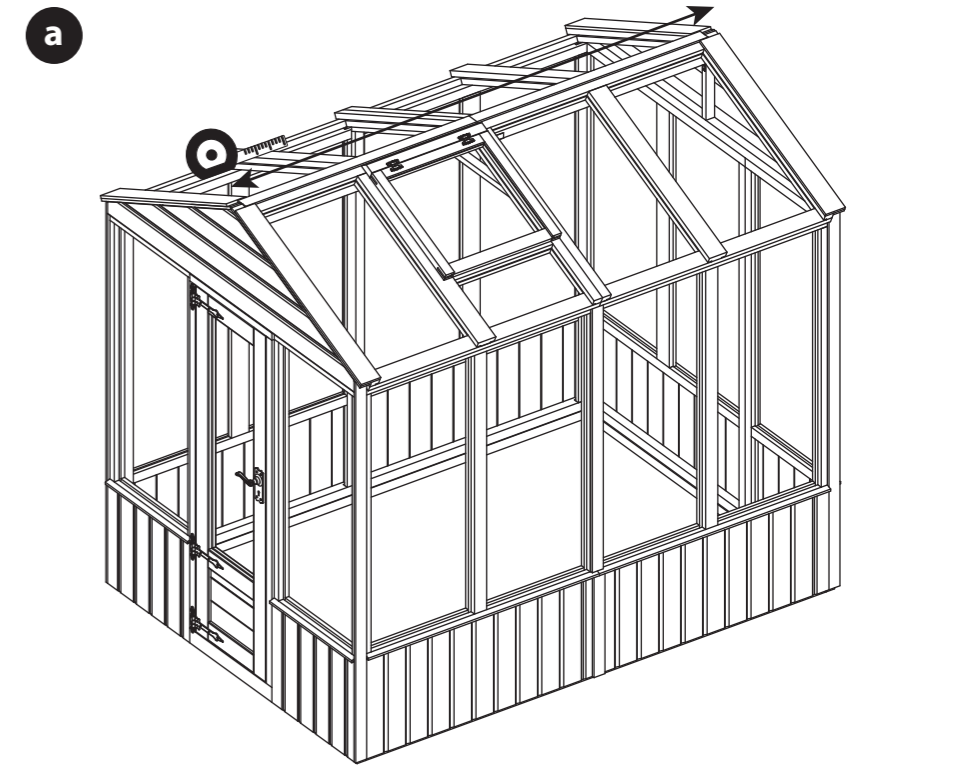

Step 28

Parts Needed

Building	No. 20	No. 30	40mm screw
All sizes	QTY 4	QTY 2	QTY 16

a Locate two Fascias (**No. 20**), to each end of the building, making sure the angled ends meet at the top of the apex.

b The Fascias (**No. 20**) will overhang past the end of the Roofs - mark the overhang onto the Fascias using a pencil or tape.

To get a neat cut, align the pre-cut angled end of a Fascia with the mark and draw a line. Using a saw, remove the excess material.

c Re-position the Fascias and secure in place using 3x40mm screws per Fascia.

Position the Finials (**No. 30**) on top of the Fascias at either end of the building and secure in place using 2x40mm screws per Finial.

Please note: the 8x6 'Door on the end' building configuration has been shown for illustrative purposes and may differ from your chosen configuration. However the process of fitting the Fascias is the same.



IMPORTANT: Pre-drill before fixing screws.

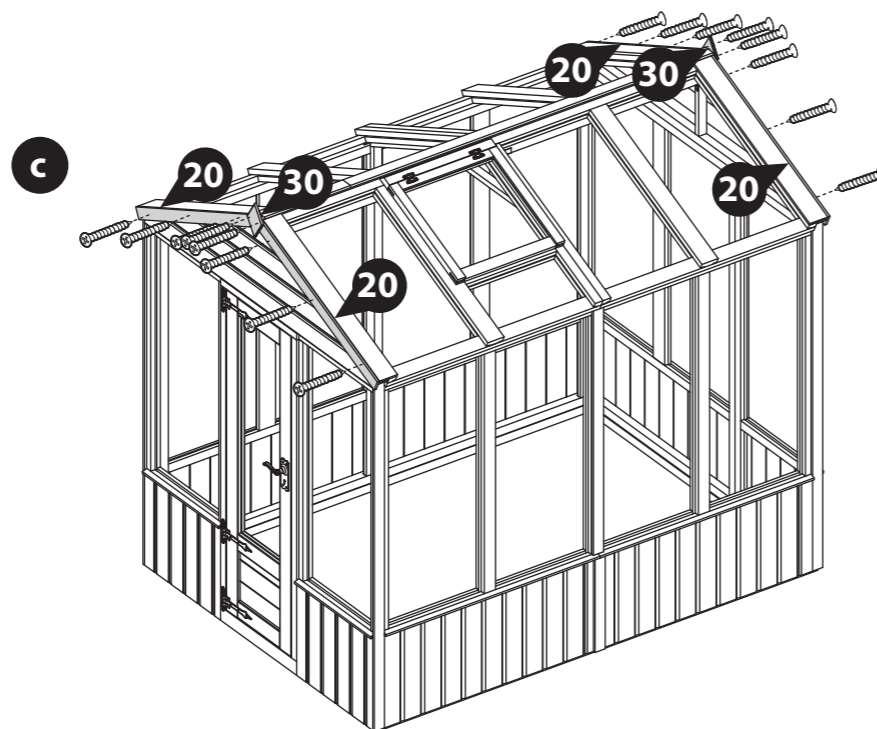
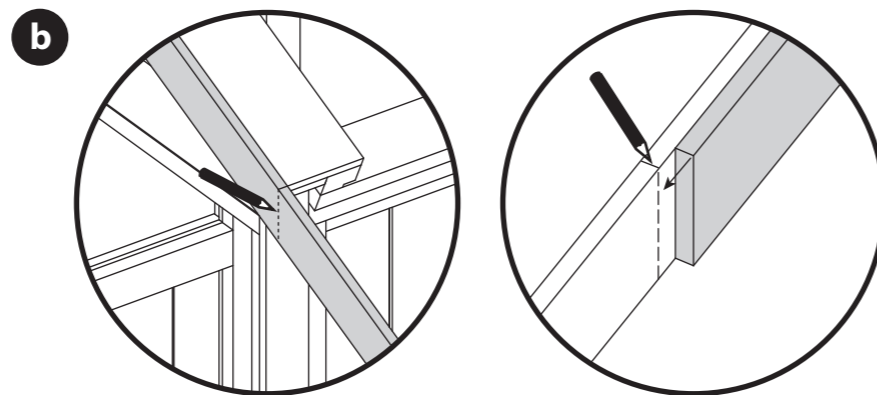
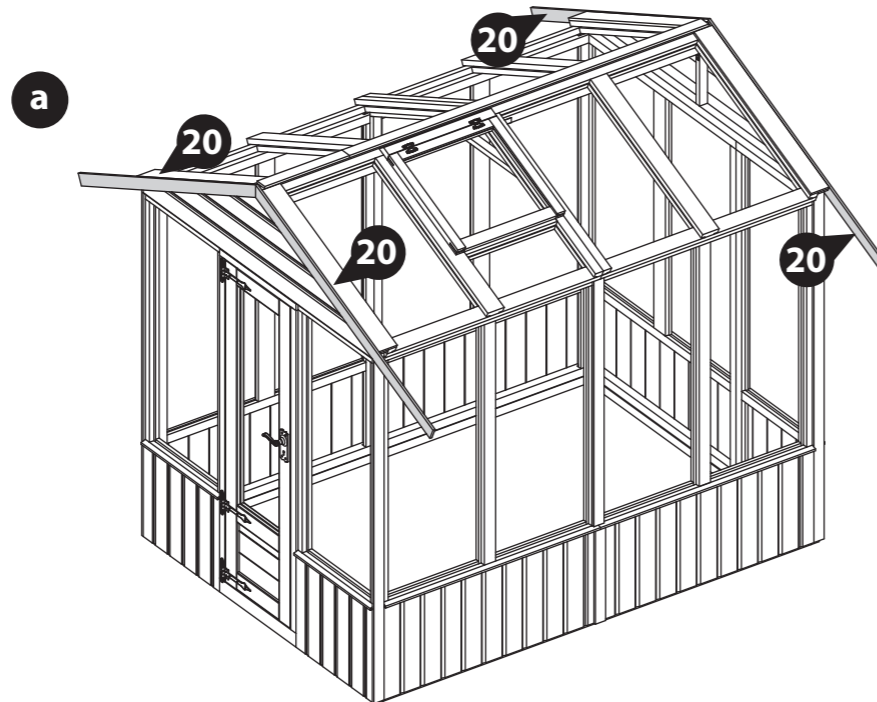

Step 29

Once constructed, apply a preserving treatment and a waterproofing treatment to your garden building as soon as possible. This will help to protect your building and prevent decay.

****Make sure to treat any loose timber components still required for the glazing of your building - such as beading strips.**

See page 31 for a full guide and instructions.

Please note: the 8x6 'Door on the end' building configuration has been shown for illustrative purposes and may differ from your chosen configuration. However the process of treating the building is the same.



Apply treatment.

Next steps...

Once your Greenhouse is constructed and treated please refer to the 'Panel Glazing' manual provided for steps on how to fit the glazing into each of your panels.

This guide must be followed to complete the construction of your Greenhouse.

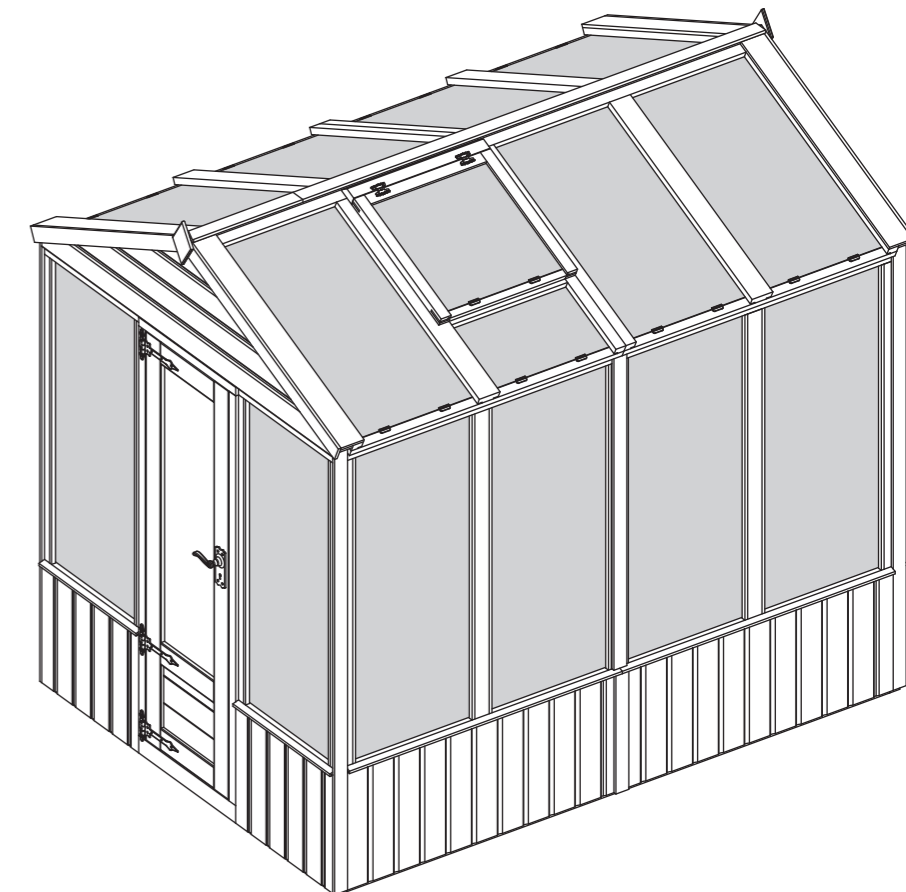
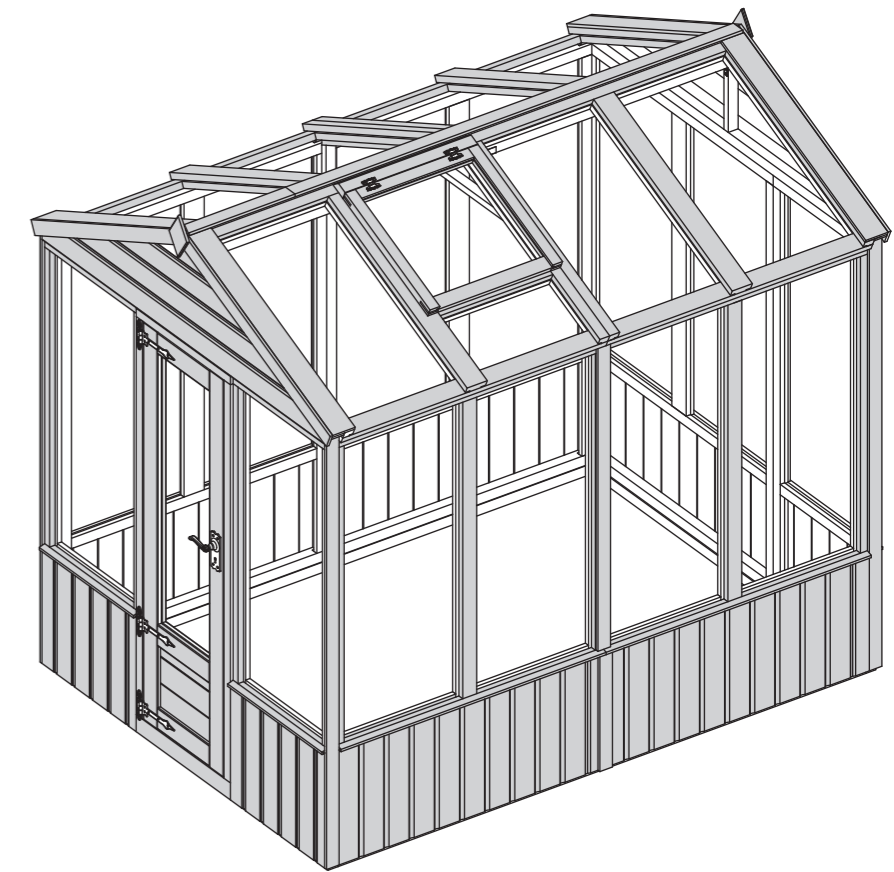



LEAVE US A REVIEW...

Want to share your experience with us?
Leave us a review on TrustPilot or Google.

Your reviews help other people find and trust our business, as well as helping to play an important role in our growth and improvement!

TREATING YOUR GREENHOUSE

Preservation of wood that's outdoors is vital. A little early care will help protect your greenhouse, improve its appearance and ensure maximum longevity. Insects, moisture, salt, and changing weather can have dramatic effects on the stability and appearance of your greenhouse. Once your greenhouse is installed, you've checked it over and you're happy with it, you can take a few basic precautions to prepare it for the elements. Treating your greenhouse helps prevent decay and, by repelling water, discourages the growth of moulds and fungi that could jeopardise the structural integrity of the wood.

Dip Treated Greenhouses - Require a preservative treatment to protect against rot and decay and a waterproof treatment to prevent water ingress



ANY QUESTIONS?
Scan the QR code to contact us via our customer portal.

To apply a preservative and water proofing treatment (pressure treated products do not require a preserver), follow the manufacturer's instructions but in principle, stick to the following steps:

- ✓ Weather permitting, ensure to treat your greenhouse within 14 days of installation.
- ✓ Wear latex or rubber gloves, eye protection and (if spraying) a mask.
- ✓ Prepare the wood, by sanding down any ridges or inconsistencies in the wood, smoothing out knots and end-cuts.
- ✓ Choose a dry day to treat your greenhouse. If you're spraying rather than brushing paint on, avoid a windy day.
- ✓ Be sure you can safely reach all the sections you need to paint - and if you need a ladder, make sure it's safely positioned before climbing. Lay dust sheets around to avoid paint splatters on your base or surrounding plants.
- ✓ Tape around windowpanes to avoid smears when you're painting the frames.
- ✓ Keep pets and small children out of the way. The last thing you want is to have fur on your garden building paint, or little painted footprints all over your garden and home.
- ✓ Fill any gaps in the greenhouse's body with caulk or wood filler to prevent water and draughts getting in. Silicone based caulk is flexible and will move with the timber when temperature and humidity change. Allow to dry completely before treating. A handy tip for finding gaps is to go into your greenhouse and look for light leaking through joins and frames. If light gets in, then so will water.
- ✓ Liberally apply at least two coats of the treatment products with a brush or spray, taking care to allow the first coat to completely dry before applying the second.
- ✓ Make sure the solution permeates the whole of the surface area, especially around natural cracks, end cuts and nail/screw holes.



APPLY WOOD TREATMENT
IMMEDIATELY
AFTER ASSEMBLY



1 Perimeter

Check around the perimeter of your product to ensure there are not trees or plants that are in contact with or overhanging the building. This can affect airflow and overhanging trees, or branches can damage the roof, it is advised to keep plants at a distance.

2 Repair

Inspect the interior and exterior of the product to look for splits, cracks, and holes. Although this is a natural occurrence it can be prevented. A wood filler can be used to close the splits, cracks, and holes.

3 Roof

Check your roof regularly for tears, splits, damaged wood and fallen debris. If you notice any of this immediate repair is critical.

4 Doors & Windows

Expansion and contraction can cause doors and windows to stick or become difficult to open. Small adjustments to the hinge position can be made to the doors and windows to allow free movement.

5 Oil

Hinges can seize up over time, apply lubricant to the hinges and locks annually.

6 Screws & Bolts

It is advised to check all screws and bolts and tighten any loose you might find. For log cabins specifically the storm braces will require loosening. During humidity and temperature changes (seasons) to allow expansion and contraction to prevent gaping, twisting, popping, and warping.

7 Wash

At least once a year, give the outside of you greenhouse a good wash, to remove cobwebs, leaves, or any other dirt that may accumulate on the exterior.

8 Airing

Airing your product regularly prevents the build up of condensation which can cause the timber to warp, bow, boards to pop, distortion, rot and mould. Condensation can build up over time or daily, it is caused by a rise and fall in temperature.

Excessive moisture levels within your building can cause water to collect on the roofs, walls and floors internally. Leaving doors and windows open regularly can help combat the natural moisture build up.

9 Clean & Tidy

It is good practice to clean the inside and outside of your product regularly. Clear out the contents, sweep the floor, remove dirt and cobwebs. Check for areas of damp and investigate the cause to remove and prevent future occurrences. Check the ground around your product for build up of debris such as leaves, remove and ensure there is clear ventilation underneath the floor.

All our greenhouses have been designed and manufactured with care and attention to be the perfect addition to your outdoor space. To ensure you do get the best out of your new greenhouse and to increase the longevity we advise that you follow the product instructions and our manufacturer's recommendations as detailed below. Thank you for choosing a Mercia Garden product!

1 Choosing the most suitable location for your greenhouse...

A minimum of 60cm should be left around the perimeter of your greenhouse to allow access for maintenance, annual treatment and to allow air flow around the building.

Where possible you should avoid placing your greenhouse underneath large trees to prevent the tree causing damage to the building.

2 Preparing the base for your garden building...

All our buildings must be built on a firm, level base to ensure the longevity of the building and prevent the wood from distorting. We recommend either concrete, concrete slabs or a wooden base, such as our 'Portabase'.

The base should be slightly smaller than the external measurement of the building, i.e. the cladding should overlap the base, creating a run off for water and preventing water from pooling underneath the building.

We also recommend that the floor of the greenhouse is a minimum of 25mm above the surrounding ground level to avoid flooding.

3 After installation...

Once your greenhouse has been installed, it will need to be treated within 14 days (weather permitting) and then annually to prevent the timber from deteriorating and to waterproof it. This is required to maintain the anti-rot guarantee.

Dip Treated greenhouses - Require a preservative treatment to protect against rot and decay

We also recommend using a silicon sealant around the glazing on the inside and outside of the windows and roofs as soon as possible after assembly and treatment to fully seal the windows.

Roofing coverings should be checked annually and replaced or fixed accordingly.

4 General maintenance and wood characteristics

As wood is a natural material it may be affected by the following:

Shrinkage and warping - The timber used in the construction of your greenhouse will have retained some of its natural moisture content. The moisture content of the timber will vary, depending upon prevailing environmental conditions, which will result in the components either naturally expanding or contracting. As the components dry out, shrinkage may occur. A good waterproofing treatment from the start is the best protection to minimise the effect of moisture loss/intake.

In extended periods of very warm weather getting some moisture to the building will help the overall balance. You can do this by spraying it down lightly with a garden hose. In contrast, after snow fall try to remove the snow as best as possible from the roof to prevent moisture intake and to remove the extra weight.

Top tip - using a garden brush will help you to reach the highest part of the building to remove snow and any debris left from bad weather.

Damp and mould - During the winter months, cold and damp conditions can result in an increased amount of moisture within your greenhouse, especially when used infrequently. Condensation can form on the timber and other items stored within your greenhouse. If left this moisture is likely to cause mould and mildew.

To prevent the build-up of moisture, we recommend leaving the door or windows of your greenhouse open from time to time, to allow the fresh air to circulate. We also advise against storing wet or damp items in your greenhouse as this will also increase the level of moisture in the building. If mould or mildew does start to form within your greenhouse we recommend using an anti-mould cleaner to remove it and to prevent it spreading, which if left untreated could permanently damage your greenhouse.

Splits, cracks and knots - You may notice small splits and cracks in some components or holes may appear where knots shrink and fall out. This will not affect the structure of your greenhouse however, if you wish to fill them this can be easily done using any good quality wood filler.

Sap - is naturally occurring in wood and may appear in some boards of your greenhouse. If you wish to remove the sap, we advise waiting until it is dry and then using a sharp knife to carefully remove it. If the removal of the sap causes a hole in the timber, we recommend using a good quality wood filler to fill it.



Any further questions?
Contact our
Customer Service Team via the
MGP Customer Portal at:
www.mgplogistics.co.uk

For more handy hints and tips on how to care and maintain your garden building please refer to the MGP Customer Portal at: www.mgplogistics.co.uk

1

Manufacturer's Warranty

All Mercia Garden Products are supplied with a 1 year warranty on all parts against manufacturing defects. This warranty does not cover movement, warping or splitting of timber products over time.

This warranty will be voided if any of the following occur:

1. The building has been customised or modified/adapted in any way.
2. The person claiming is not the original purchaser of the building.
3. Any damage has been caused by or as a result of misuse.
4. The building has not been maintained and cared for in accordance to our advisories and manufacturer's recommendations.
5. The building has not been treated annually or as per the manufacturer's recommendations, please ensure receipts are kept to validate this claim.
6. The building has not been erected, fitted or installed as per the supplier instructions.
7. The building has not been erected on a suitable sized firm flat, solid level concrete/slab base or placed on pressure treated bearers.
8. The building is or has been placed with 2 feet (600mm) of any obstructions (walls, trees, plants, fences etc.) which can allow moisture to penetrate the timber.
9. The roofing felt has been incorrectly fitted or damaged, allowing water ingress, or has not been properly maintained.
10. Any windows and joints have not been sealed, inside and out, with silicone or other watertight sealant.
11. Any timber has been cut, pierced or drilled without subsequent application of approved cut-end treatment.

REGISTER FOR YOUR
15 YEAR
ANTI-ROT
GUARANTEE TODAY



www.mgplogistics.co.uk

2

Anti-rot Guarantee

Mercia Garden Products offer a 15 year anti-rot guarantee on dip treated (a preparatory treatment) and 20 years on pressure treated products within this range. This guarantee covers solid timber against rot, decay, blue stain and insect attacks.

To validate the guarantee, the building must be treated (as detailed within manufacturer's recommendations) within 14 days (weather permitting) of assembly and annually thereafter. This guarantee does not cover movement, warping or splitting of timber products over time.

This guarantee will be voided if any of the following occur:

1. The building has been customised or modified/adapted in any way.
2. The person claiming is not the original purchaser of the building.
3. Any damage is caused by or as a result of misuse.
4. The building has not been maintained and cared for in accordance to our advisories and manufacturer's recommendations.
5. The building has not been treated annually or as per the manufacturer's recommendations, please ensure receipts are kept to validate this claim.
6. The building has not been erected, fitted or installed as per the supplier instructions.
7. The building has not been erected on a suitable sized firm flat, solid level concrete/slab base or placed on pressure treated bearers.
8. The building is or has been placed with 600mm of any obstructions (walls, trees, plants, fences etc.) which can allow moisture to penetrate the timber.
9. The roofing felt has been incorrectly fitted or damaged allowing water ingress, or has not been properly maintained.
10. Any windows and joints have not been sealed, inside and out, with silicone or other watertight sealant.
11. Any timber has been cut, pierced or drilled without subsequent application of approved cut-end treatment.