

6FT APEX COMBI SHED AND GREENHOUSE

Please retain product label and instructions for future reference

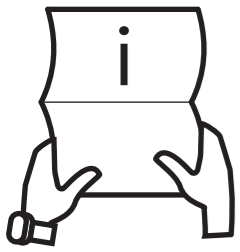

BEFORE YOU START PLEASE READ THE INSTRUCTIONS CAREFULLY

- Check the pack and make sure you have all the items listed in the parts list provided.
- When you are ready to start, make sure you have the right tools at hand (not supplied - see the equipment list on next page).
- Ensure there is plenty of space and a clean dry area for assembly.
- Ensure you have enough time to fully assemble the main structure of your Garden Building.

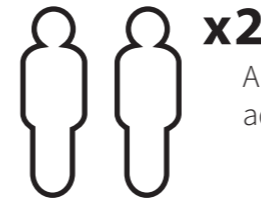

x2
All buildings should be erected by two adults

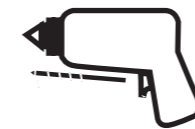

2mm Drill bit

For ease of assembly, you **MUST** pilot drill all screw holes and ensure all screw heads are countersunk.



For ease of assembly, you will need a tape measure to check dimensions of components and fixings.



Winter = High Moisture = Expansion
Summer = Low Moisture = Contraction



CAUTION

Every effort has been made during the manufacturing process to eliminate the prospect of splinters on rough surfaces of the timber. You are strongly advised to wear gloves when working with or handling rough sawn timber.

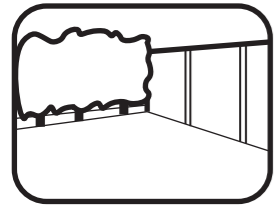

LOCATION FOR YOUR GREENHOUSE

- Ensure you have a suitable space available and cleared before beginning assembly:
- A minimum of 600mm should be left around the perimeter of your garden building to allow access for maintenance, annual treatment and to allow air flow around the building.
 - To fit your glazing, you require a minimum of 1000mm clearance on either side of your Greenhouse. These must be the sides where the lowest ends of the roofs (bottom of the apex) will be positioned.
 - Where possible, avoid placing your garden building underneath large trees to prevent the tree causing damage to the building.

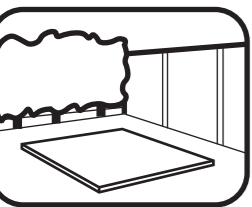

BUILDING A BASE

When thinking about where the building and where the base is going to be constructed: Ensure that there will be access to all sides for maintenance work and annual treatment.

Ensure the base is level and is built on firm ground, to prevent movement. Refer to pages 5-7 for the base dimensions. The base should be slightly smaller than the external measurement of the building, i.e. The cladding should overlap the base, creating a run off for water. It is also recommended that the floor be at least 25mm above the surrounding ground level to avoid flooding.

TYPES OF BASE

- Concrete 75mm laid on top of 75mm hard-core.
- Slabs laid on 50mm of sharp sand.
- Wooden base - Levelled / on posts / ground screws.

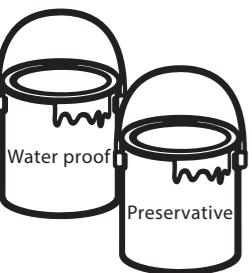

TREATMENT

Once your garden building has been installed it will need to be treated within 14 days (weather permitting) and annually to prevent the timber from deteriorating and to waterproof it. This is required to maintain the anti-rot guarantee.

Dip Treated buildings - Require a preservative treatment to protect against rot and decay and a waterproof treatment to prevent water ingress.

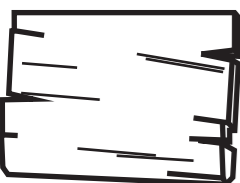

TIMBER

As with all natural materials, timber can be affected during various weather conditions. For the duration of heavy or extended periods of rain, swelling of the wood panels may occur. Warping of the wood may also occur during excessive dry spells due to an interior moisture loss. Unfortunately, these processes cannot be avoided but can be helped. It is suggested that the outdoor building is sprayed with water during extended periods of warm sunshine and sheltered as much as possible during rain or snow.

REGISTER FOR YOUR
10 YEAR
ANTI-ROT
GUARANTEE TODAY

In all instances for assistance with your product or to register your anti rot guarantee, please contact us via our customer portal



www.mgplogistics.co.uk

Mercia Garden Products Limited, Sutton On Trent, Newark, Nottinghamshire, NG23 6QN

Screws & Nails

Measure overall length

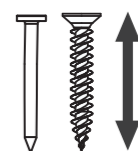

Bolts

Measure under the head



Protim Aquatan T5 (621)

Your building has been dip treated with Aquatan.

Aquatan is a water-based concentrate which is diluted with water, the building has been treated by the correct application of Aquatan solution and then allowed to dry.

Aquatan is a decorative finish to colour the wood, which is applied industrially to timber fence panels and garden buildings.

Aquatan undiluted contains: boric acid, sodium hydroxide 32% solution, aqueous mixture of sodium dioctyl sulphosuccinat and alcohols: 2, 4, 6-trichlorophenol.



TO DO LIST

- Find a suitable location to build (*see front cover for further information*).
- Build a base (*see front cover for further information*).
- Check the base is flat, level, clear of debris and has the required clearance on all sides (see page 1).
- Check you have the required equipment / tools.
- Check you have all the product items listed (*if you have missing or damaged parts please scan the QR code below to visit our online customer portal*).
- Install the product as per the step by step instructions within this pack.
- Prepare the product ready for treatment (this may include sanding).
- Apply a preserving and a waterproofing treatment within 14 days (*weather permitting*) of installation (*pressure treated products do not require a preserver*).
- Register for your anti rot guarantee (*scan the QR below*).
- Tidy the build area and dispose of any remaining parts responsibly.
- Maintain your building (*see the manufacturers recommendations at the back of this pack*).

EQUIPMENT LIST

- Hammer
- Flat Head Screwdriver
- Drill
- Drill Bit Set
- Phillips and Slotted Bit Sets
- Tape Measure
- Hand Saw
- Spirit Level
- Ladders/Steps
- Stanley Knife/Cutting Tool
- Sand Paper
- Gloves
- Silicone (For Windows Only)
- Sealant Application Gun
- Wood Filler (Optional)
- Timber Preservative Treatment (*not pressure treated products*)
- Timber Water Proofing Treatment
- Treatment Mixing Stick
- Paint Brush/Sprayer/Roller

NEED EXTRA SUPPORT

If you are unsure that your base preparation will be suitable, please contact us via our customer portal to discuss this further.

Alternatively, you can visit our website or MGP Logistics Online Portal for some further shededucation.

Website:

<https://www.merciagardenproducts.co.uk/sheducation>

MGP Logistics Online Portal:

<https://www.mgplogistics.co.uk/>

Here you will find plenty of useful information that'll help with most pre-installation and maintenance queries.



ANY QUESTIONS?

Scan the QR code to contact us via our customer portal.

NOTES

ACCESSING VIDEO GUIDES...

Some steps within this set of instructions come with an added video guide for your convenience. These can be accessed via the QR code and used to aid you in constructing that step. See below for how to use.

You can also find all the videos on our youtube channel:
<https://www.youtube.com/@merciagardenproducts8716/videos>

1. Find the QR code within the instruction step...

Step.....

Parts Needed- No. QTY 1
No. QTY 1
No. QTY 1

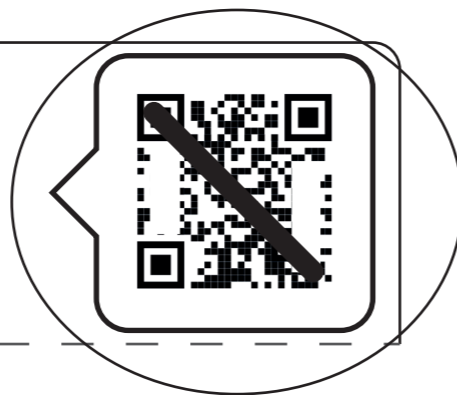

Within the instruction step, there will be an icon in the top right that has a QR code in. This is where the video can be accessed from.

Please note: not every step has a video guide.

2. Open camera app...

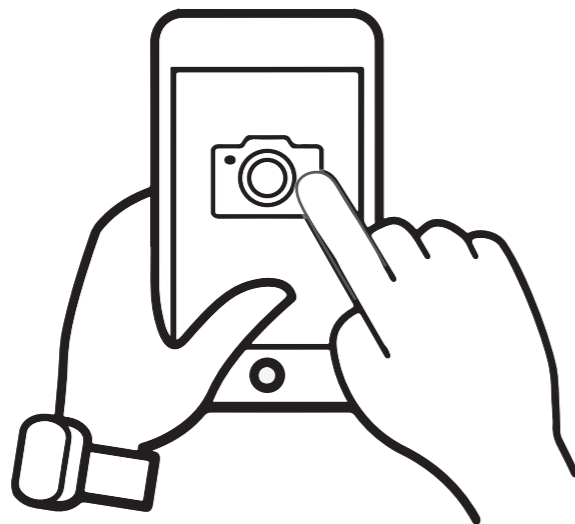

On your personal smart device (phone, tablet etc), open your camera app or QR code scanner app.

ACCESSING VIDEO GUIDES...

3. Scan QR code...



To scan the QR code, hold the camera over the QR code so that it can be seen on the screen. Once the QR code has been registered, follow the prompts on your device to open the video. (This will vary depending on your device.)

www.merciagardenproducts.co.uk P 9

Please note: Ensure to use the back camera of your smart device as this will scan the QR code more accurately.

4. Watch the video...

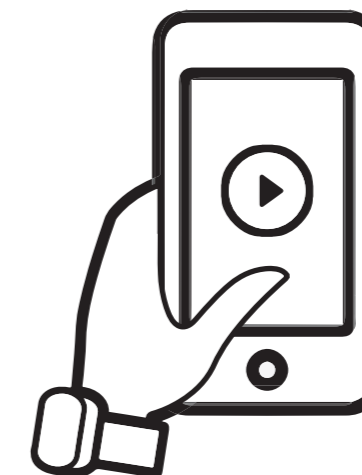

The video guide will now be displayed on your smart device.

Disclaimer: The garden building constructed in the video guides may be constructed differently to your building. Please ensure to read your instructions carefully to avoid error.

What is a Modular Garden Building?

A Modular Product allows you to choose the layout of your Garden Building, yourself.

In your Modular Combi Shed and Greenhouse this means that some panels are interchangeable with each other, such as:

The 4ft Shed Door, Shed Window and Shed Plain Panels (No. 4a, 4b & 4c) are interchangeable with each other, and can be swapped and positioned however you choose.

The 2ft Door and Glazed Panels (No. 9a & 9b) are interchangeable with each other, and can be swapped and positioned however you choose.

Please note: The buildings shown may differ in size from your chosen building however the process of interchanging the Panels is the same.

How should I position my panels?

This instruction manual contains steps to construct three different sized buildings;

- 10x6 Apex Combi - 6x6 Apex Shiplap shed + 4x6 Apex Greenhouse.
- 12x6 Apex Combi - 6x6 Apex Shiplap shed + 6x6 Apex Greenhouse.
- 14x6 Apex Combi - 6x6 Apex Shiplap shed + 8x6 Apex Greenhouse.

Each of these buildings can be constructed with the panels in different configurations, as explained above.

Please see the following pages for some inspiration of different ways you can position your panels for your chosen building size and type. Ensure you have decided how you would like your building to look before beginning construction.

We recommend positioning your Greenhouse Door centrally on one end, as this allows for the most usable space inside your Greenhouse. However, the Greenhouse Door can be placed in any position.

What building do I have?

All of our modular garden buildings have different names and different components, so it's important to understand what building you have and what comes with it before beginning assembly. Please refer to the information below to check what type of building you have before beginning construction.

6ft Apex Combi Greenhouse.

The building you have purchased is referred to generically as a '6ft Apex Combi Greenhouse' and this instruction manual contains steps to construct three different sized buildings;

- 10x6 Apex Combi = 6x6 Apex Shiplap shed + 4x6 Apex Greenhouse.
- 12x6 Apex Combi = 6x6 Apex Shiplap shed + 6x6 Apex Greenhouse.
- 14x6 Apex Combi = 6x6 Apex Shiplap shed + 8x6 Apex Greenhouse.

You will have purchased one of these buildings and have the components to build only that.

For your exact building reference codes and a full building breakdown, please see the pages to follow that contain your chosen building size. For base options, please see the 6ft Base assembly instructions guide.

What does the building name mean?

The building you have purchased will be named as shown above, for example: **14x6 Apex Combi**.

14x6 Apex Combi:

14 - the depth of the building. This building is 14ft deep.

6 - the width of the building. This building is 6ft wide.

Apex - the roof type. An Apex roof is where the roof shape meets at a central point and can look like a triangle.

Combi - the building structure. This building consists of a 6x6 Apex shiplap shed and a 8x6 Apex Greenhouse. Which together, make up the 14ft depth and both have a 6ft width.

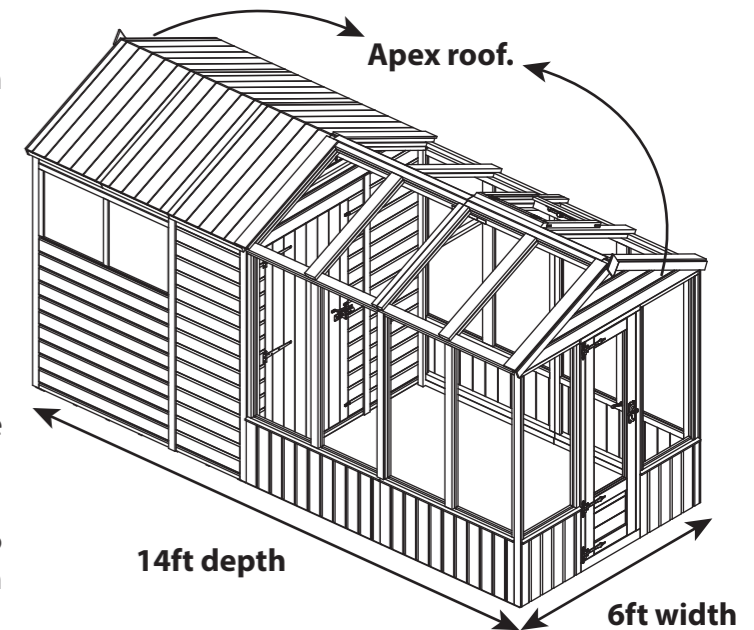

All of the buildings in this manual are 6ft wide, with differing depths. Throughout the instructions, ensure to check that you are referring to the correct building where necessary.



ANY QUESTIONS?

Scan the QR code to contact us via our customer portal.

10x6 6x6 Apex Shiplap Shed + 4x6 Apex Greenhouse

Standard Base

Overall Dimensions:
 Width = 1906mm
 Depth = 3150mm
 Height = 2286mm

Premium Base

Overall Dimensions:
 Width = 1906mm
 Depth = 3150mm
 Height = 2286mm

Greenhouse Door on the end, Shed Door on the inside.

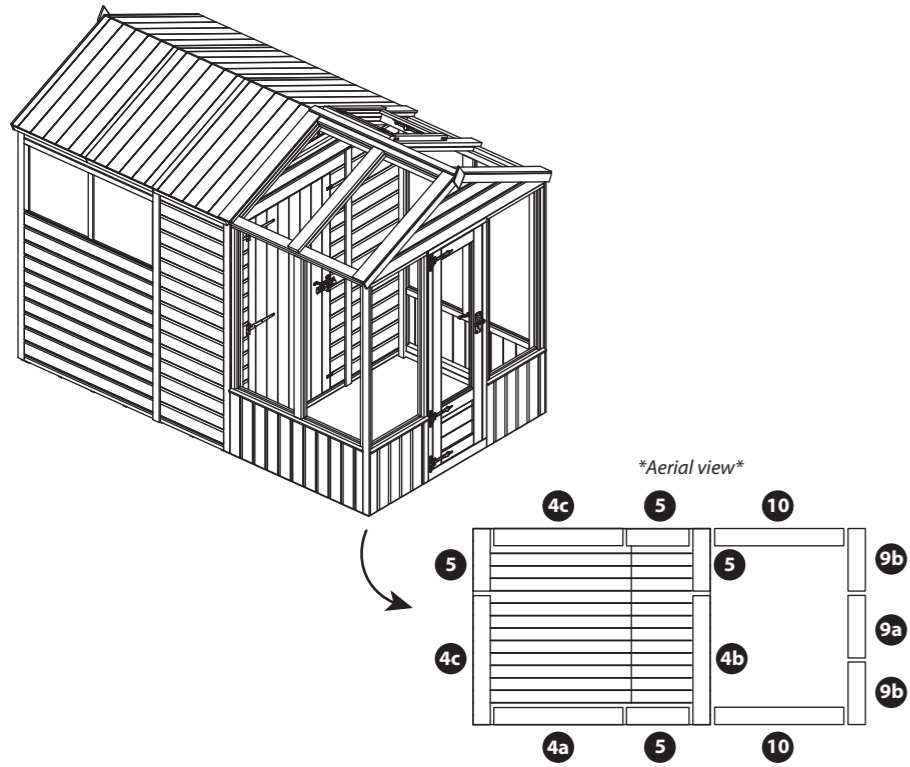

Greenhouse Door on the end, Shed Door on the side.

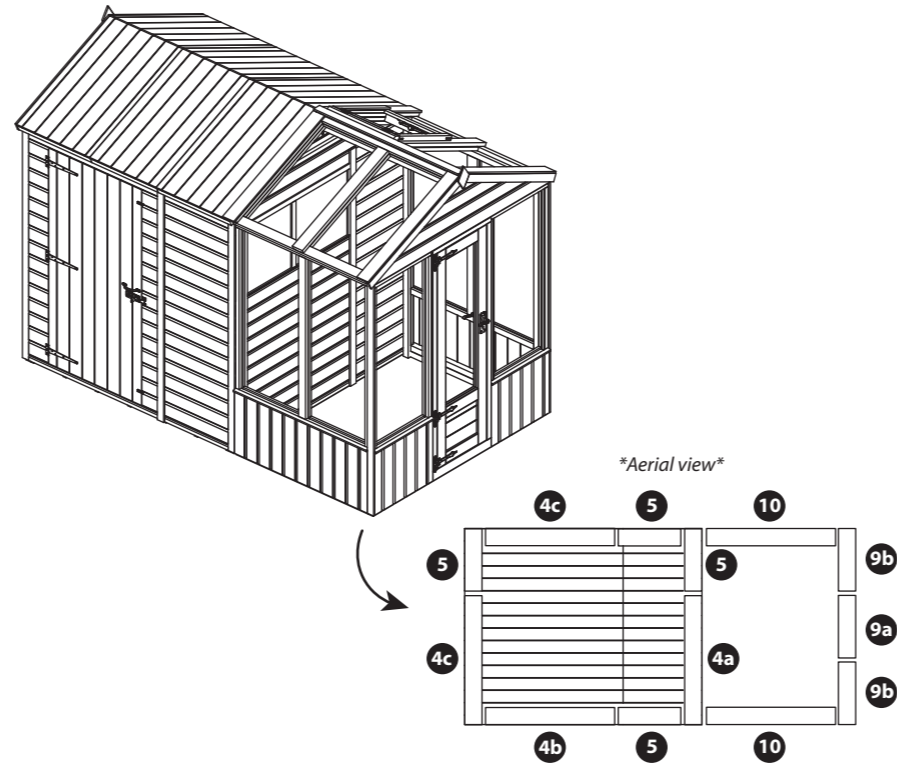

Greenhouse Door on the end, Shed Door on the back.

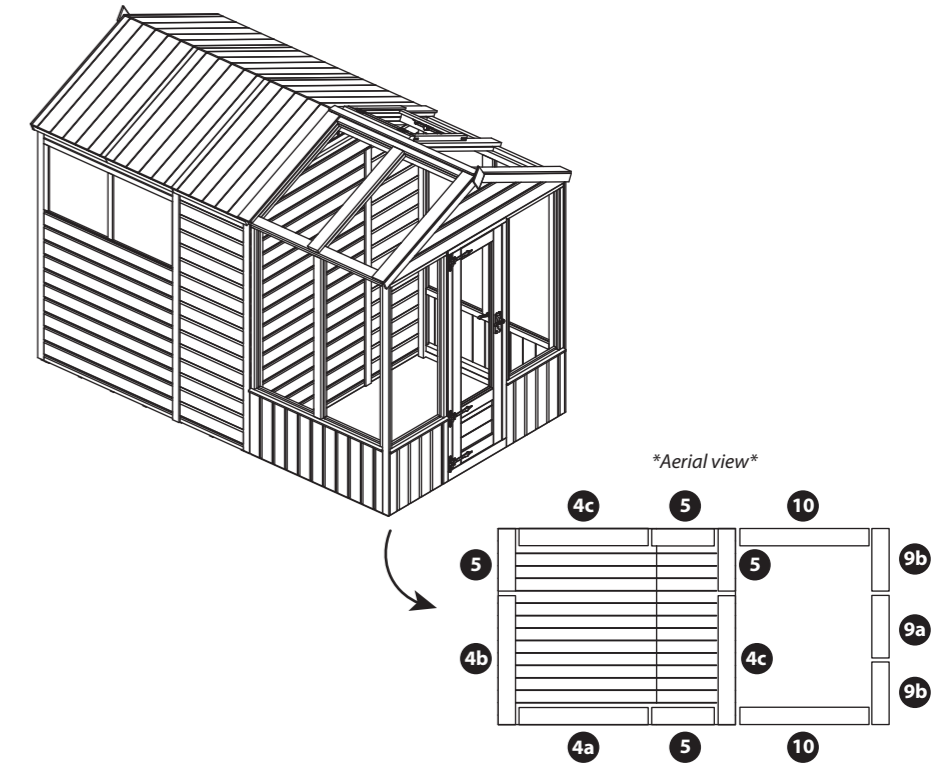

Greenhouse Door on the side, Shed Door on the inside.

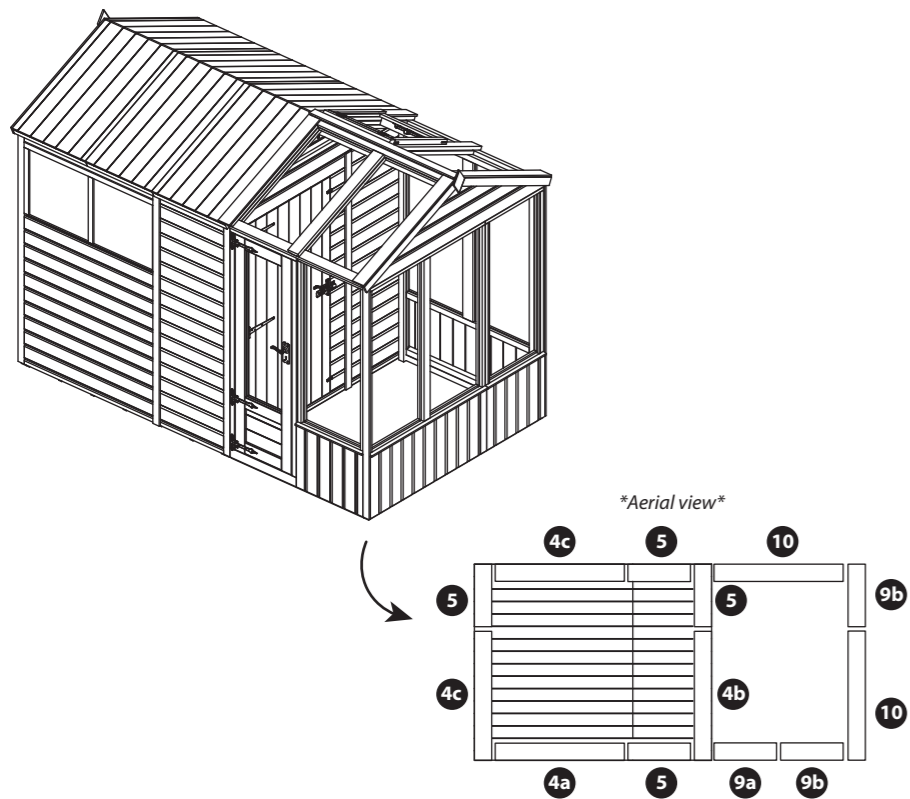

Greenhouse Door on the side, Shed Door on the side.

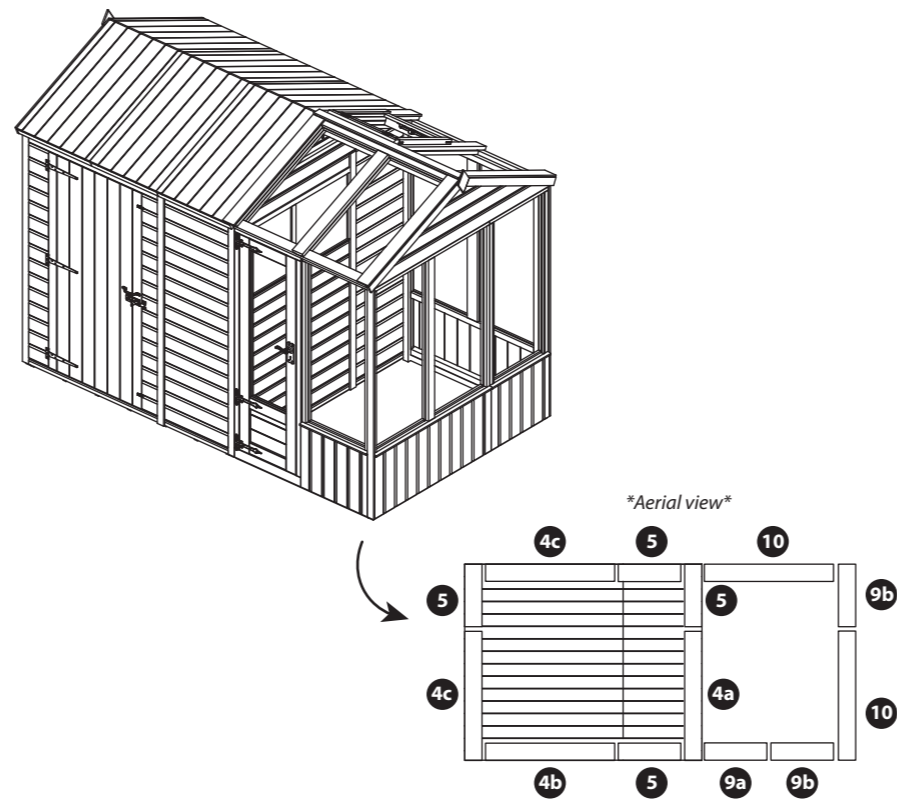

Greenhouse Door on the side, Shed Door on the back.

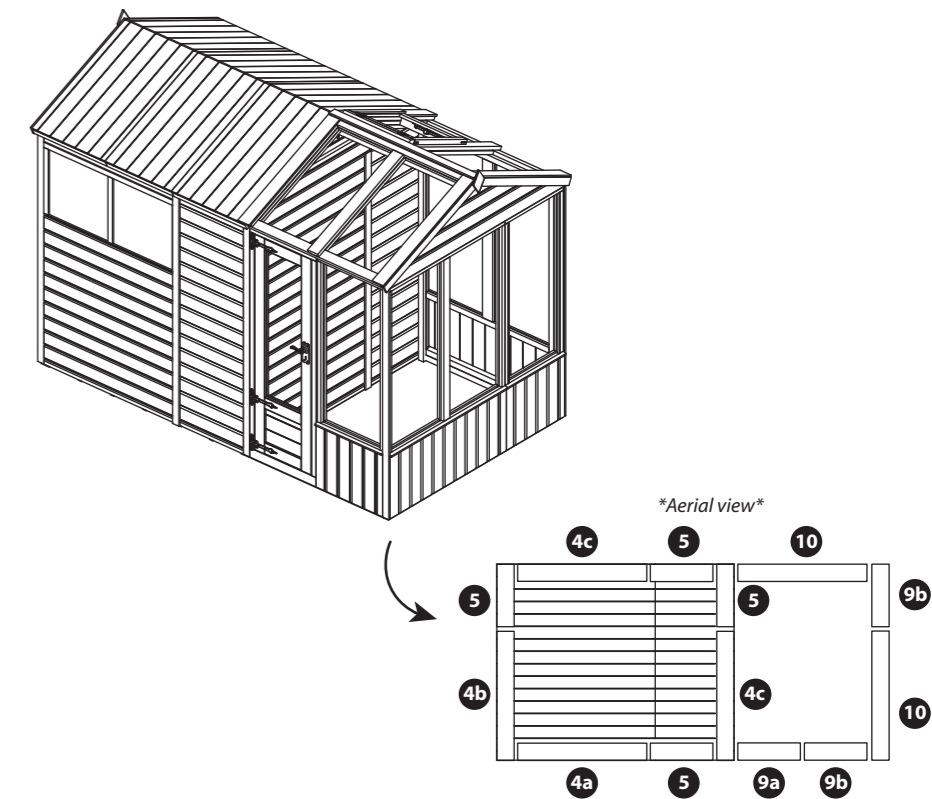

Building Breakdown

- SI-100-004-0004 - 10x6 Apex Greenhouse and Shed Combi with Styrene.

12x6 6x6 Apex Shiplap Shed + 6x6 Apex Greenhouse

Standard Base

Overall Dimensions:
 Width = 1906mm
 Depth = 3740mm
 Height = 2286mm

Premium Base

Overall Dimensions:
 Width = 1906mm
 Depth = 3740mm
 Height = 2286mm

Base Dimensions:
 Width = 1770mm
 Depth = 3665mm

Building Breakdown

◦ SI-100-004-0012 - 12x6 Apex Greenhouse and Shed Combi with Styrene.

Greenhouse Door on the end, Shed Door on the inside.

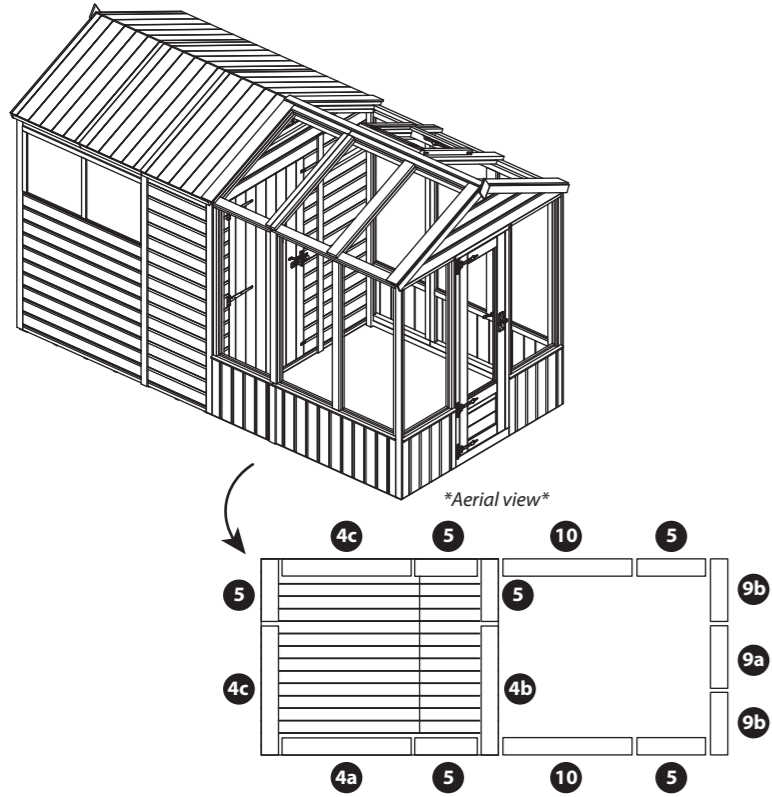

Greenhouse Door on the end, Shed Door on the side.

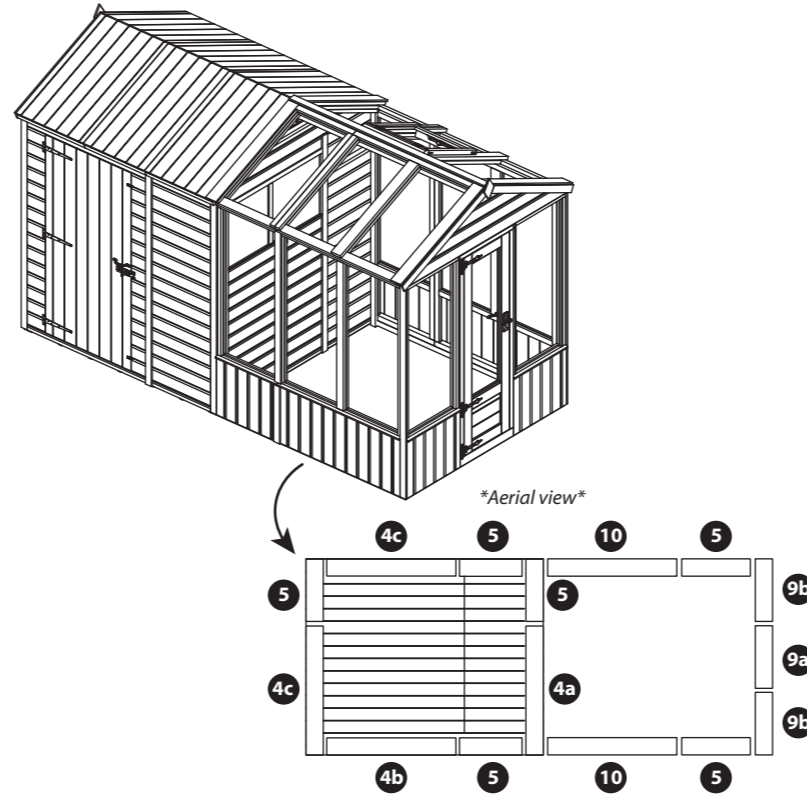

Greenhouse Door on the end, Shed Door on the back.

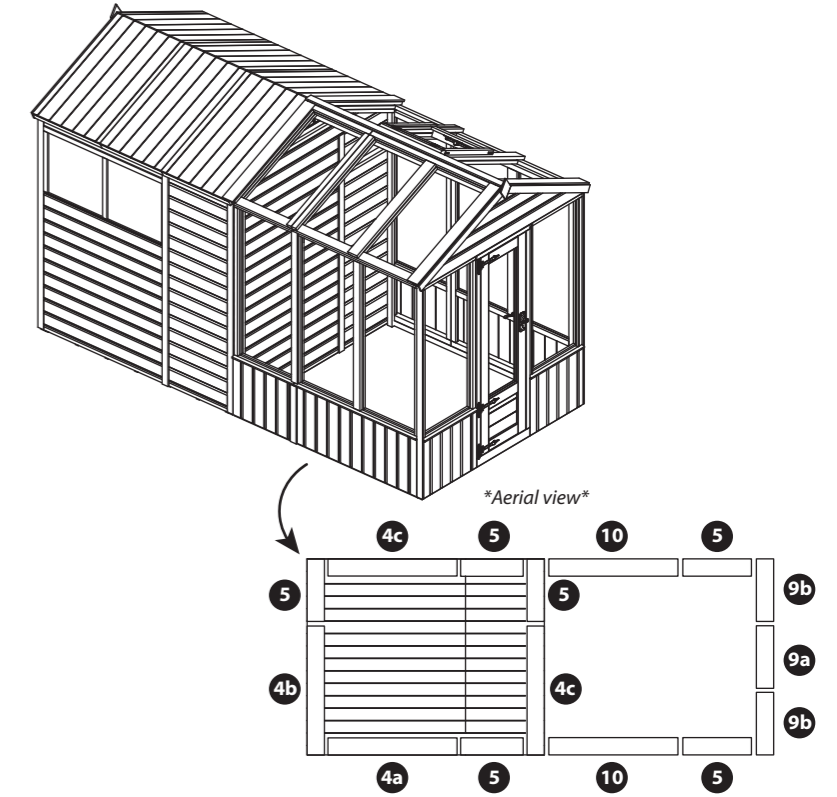

Greenhouse Door on the side, Shed Door on the inside.

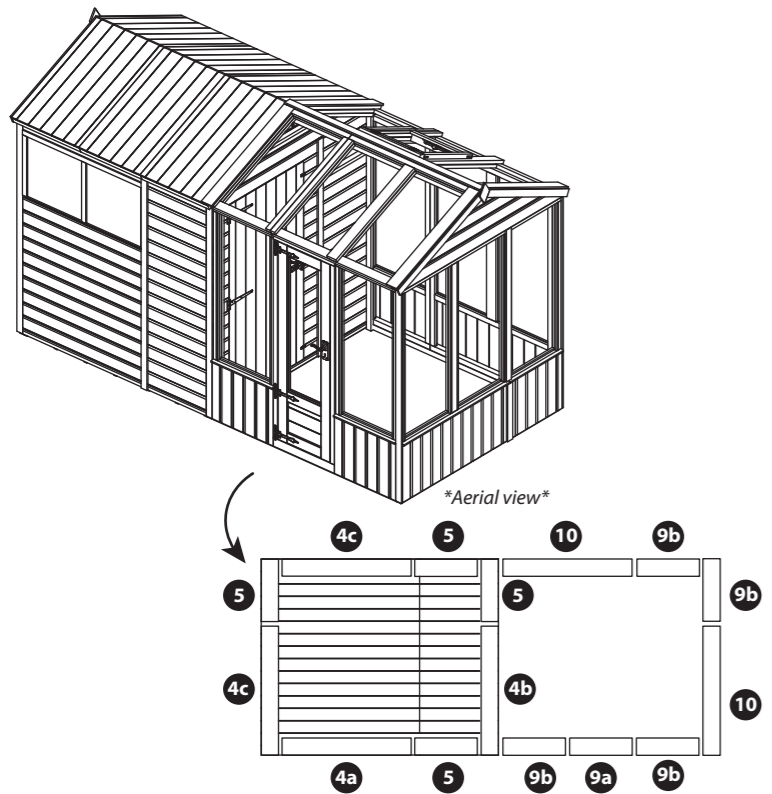

Greenhouse Door on the side, Shed Door on the side.

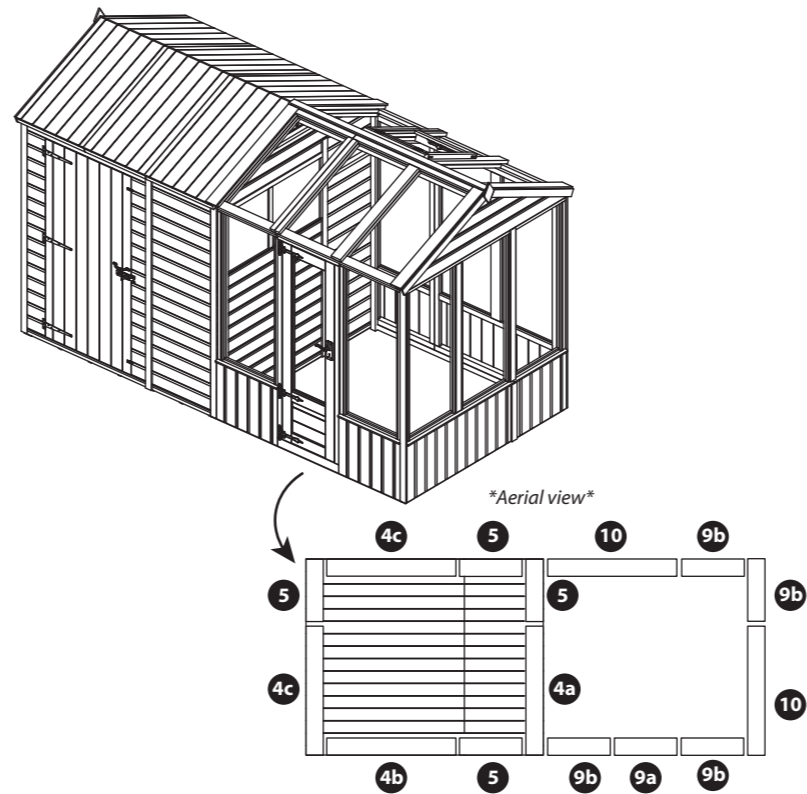

Greenhouse Door on the side, Shed Door on the back.

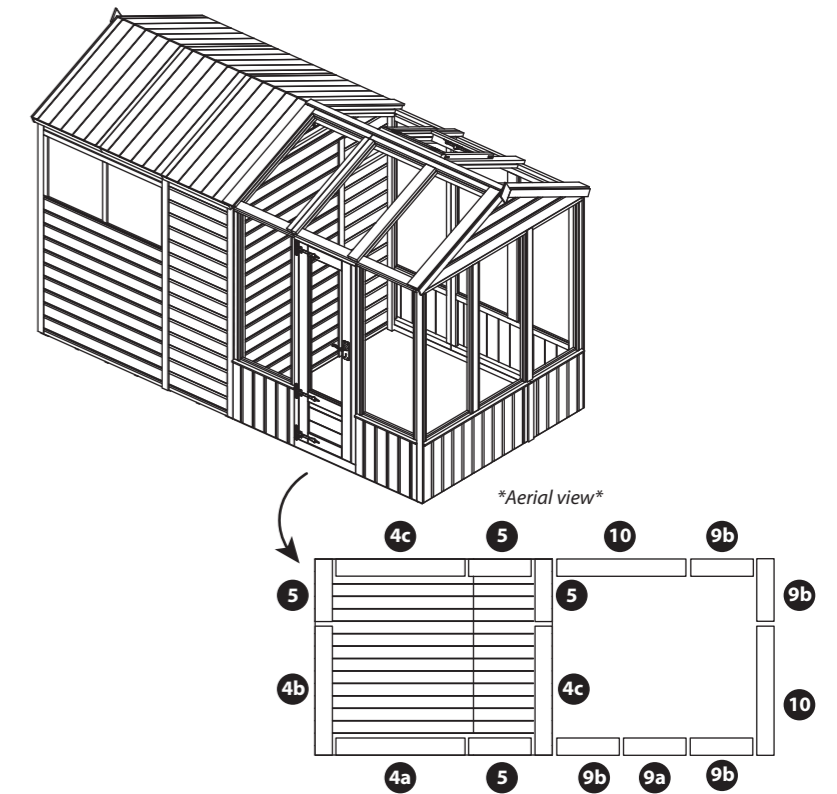

14x6 6x6 Apex Shiplap Shed + 8x6 Apex Greenhouse

Standard Base

Overall Dimensions:
 Width = 1906mm
 Depth = 4330mm
 Height = 2286mm

Premium Base

Overall Dimensions:
 Width = 1906mm
 Depth = 4330mm
 Height = 2286mm

Base Dimensions:
 Width = 1770mm
 Depth = 4255mm

Building Breakdown
 ◦ SI-100-004-0020 - 14x6 Apex Greenhouse and Shed Combi with Styrene.

Greenhouse Door on the end, Shed Door on the inside.

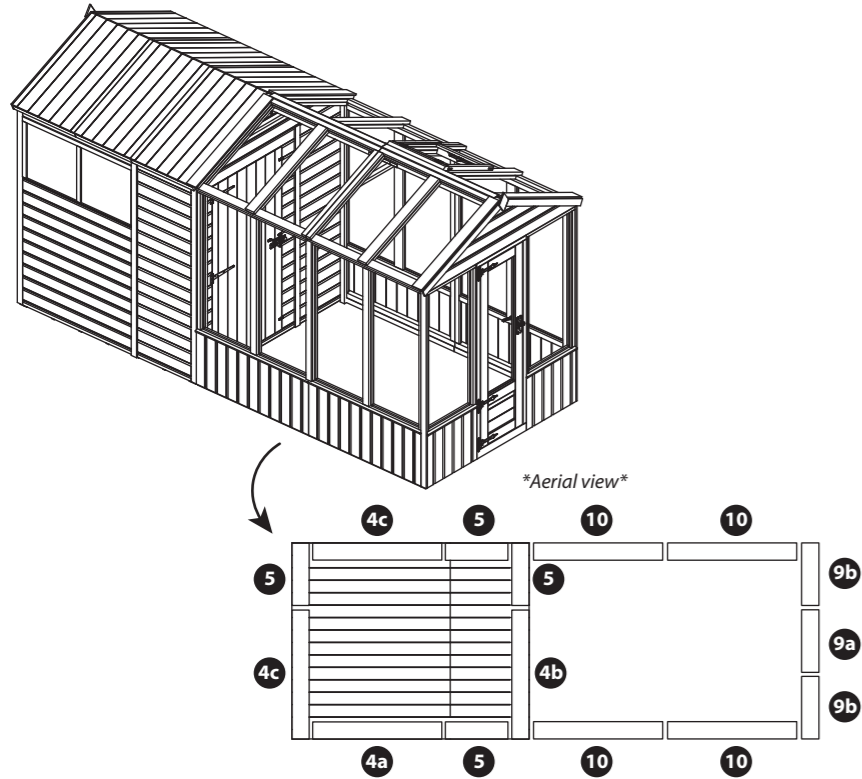

Greenhouse Door on the end, Shed Door on the side.

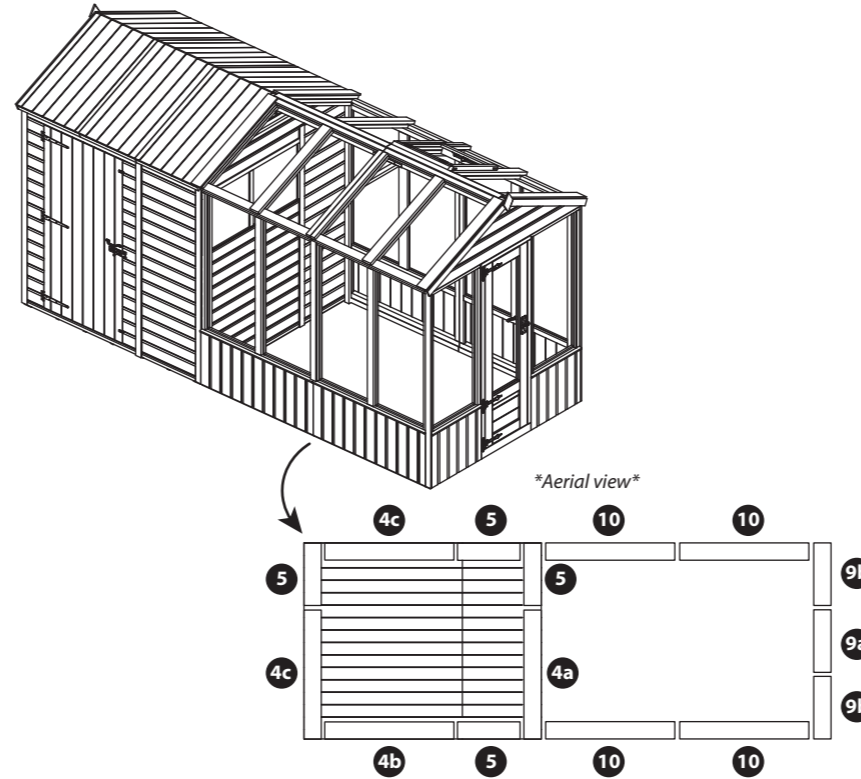

Greenhouse Door on the end, Shed Door on the back.

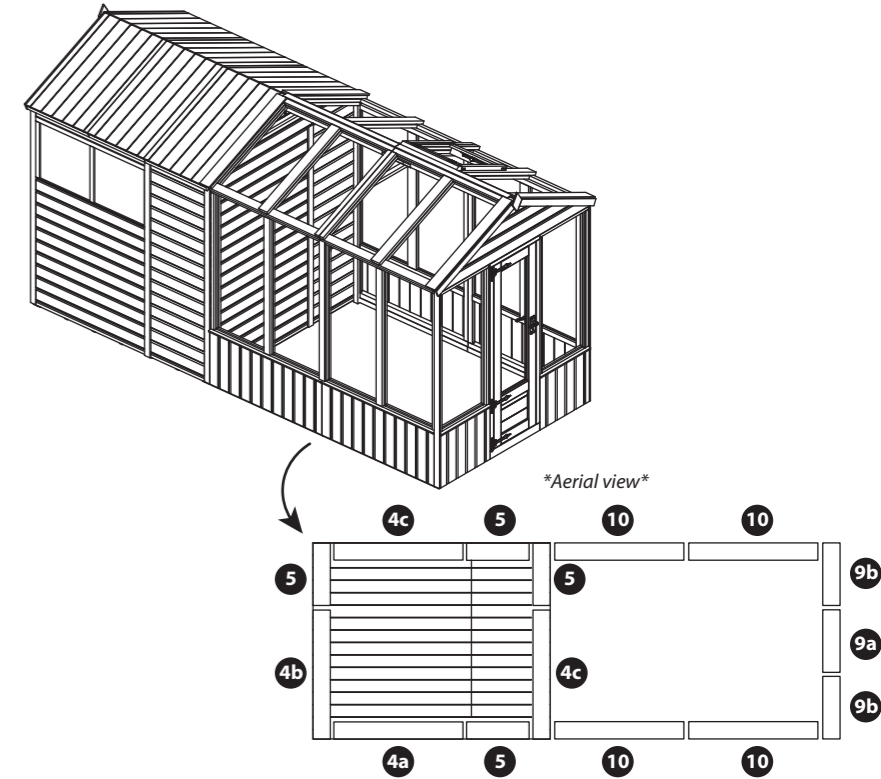

Greenhouse Door on the side, Shed Door on the inside.

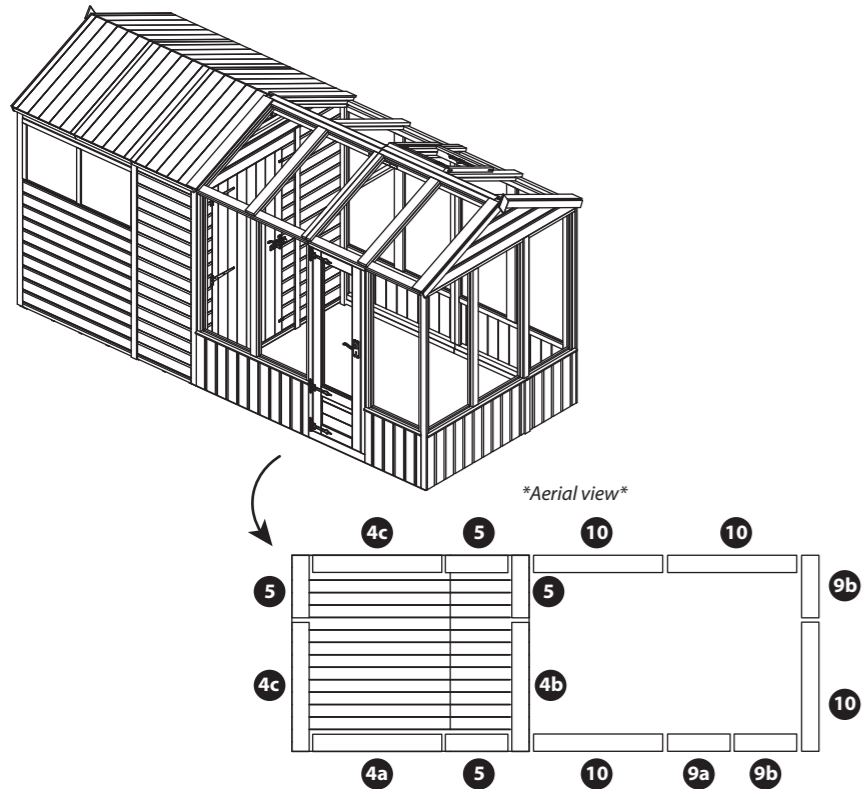

Greenhouse Door on the side, Shed Door on the side.

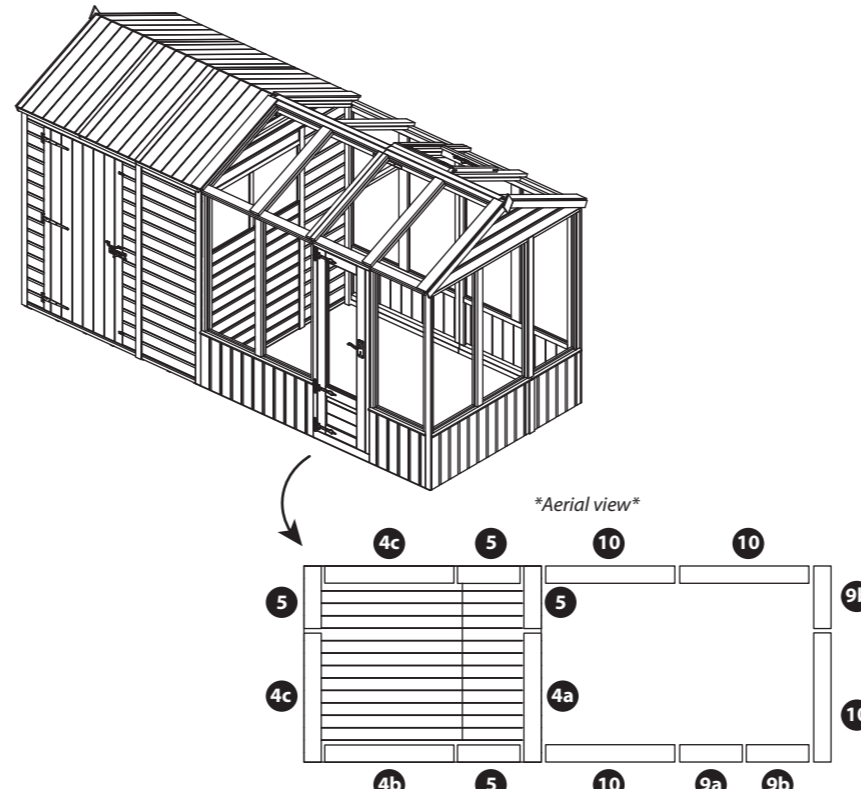

Greenhouse Door on the side, Shed Door on the back.

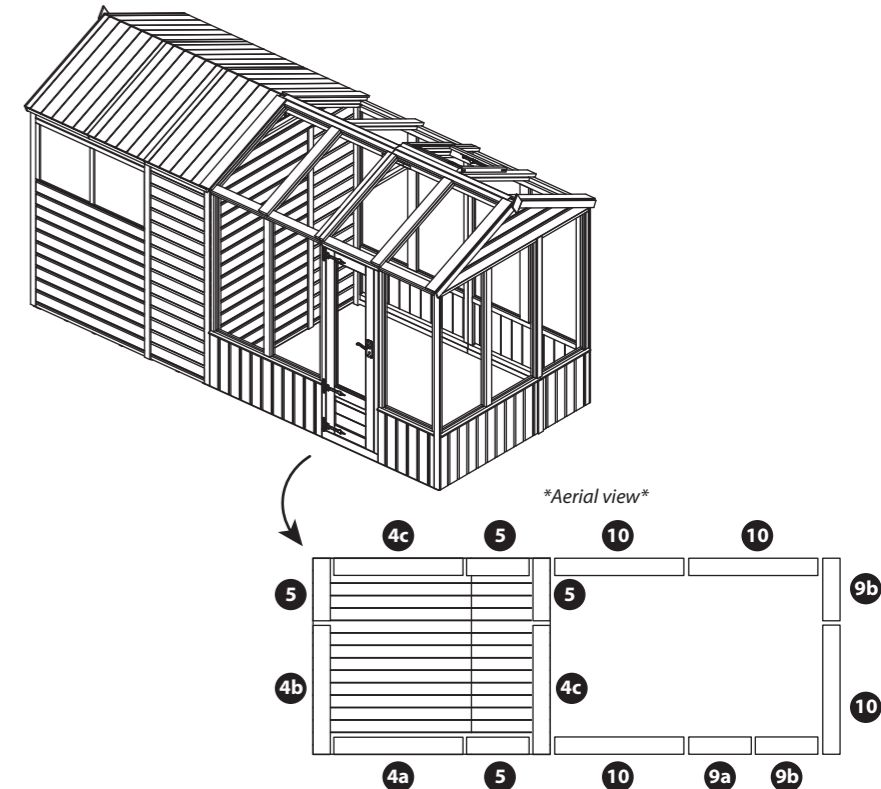

Building Contents:

In the tables to follow, please refer to the row with your chosen building size in to determine how many of each part is required.

Tip: Labelling your parts, using a pencil and masking tape, may help you to identify them easier when you need them.



We highly recommend checking you have all the required components before beginning assembly.

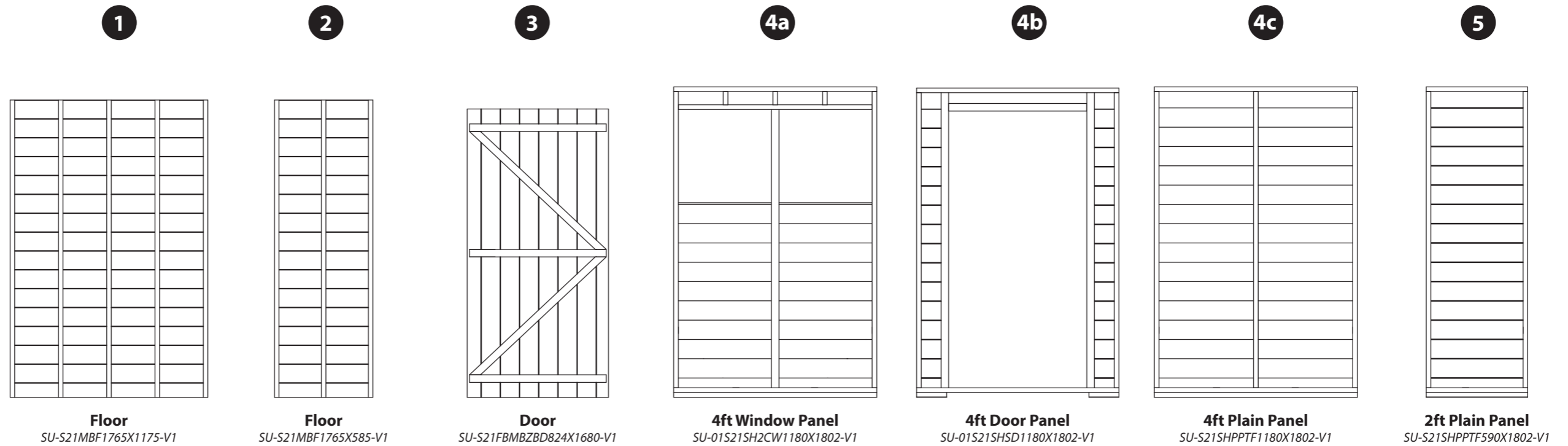

10 X 6 APEX COMBI	QTY 1	QTY 1	QTY 1	QTY 1	QTY 1	QTY 2	QTY 4
12 X 6 APEX COMBI	QTY 1	QTY 1	QTY 1	QTY 1	QTY 1	QTY 2	QTY 4
14 X 6 APEX COMBI	QTY 1	QTY 1	QTY 1	QTY 1	QTY 1	QTY 2	QTY 4

Building Contents:

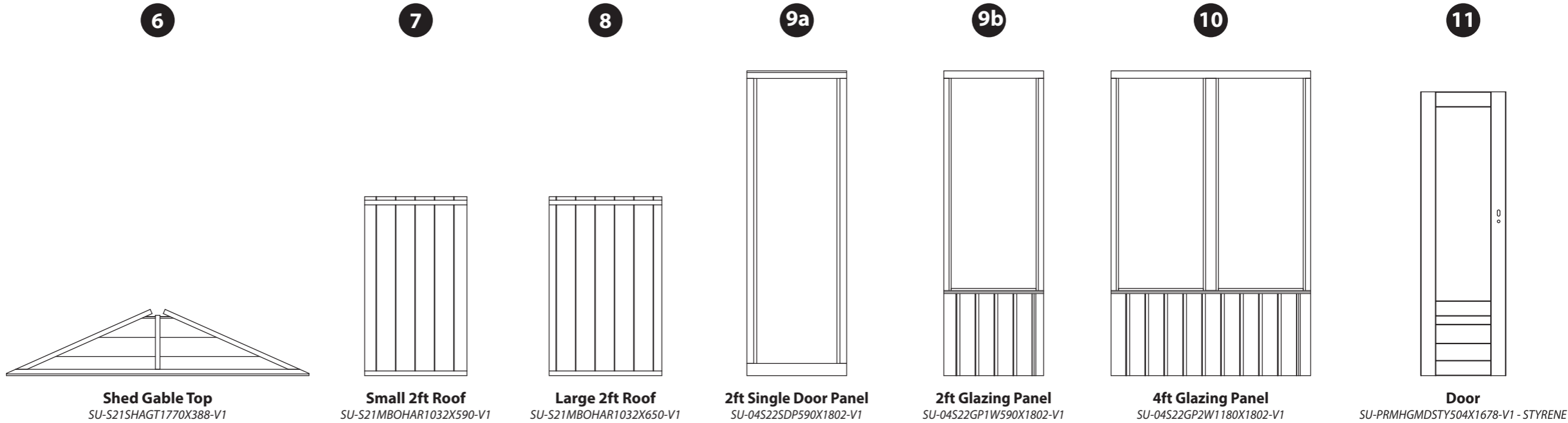

	6	7	8	9a	9b	10	11
10 X 6 APEX COMBI	QTY 2	QTY 2	QTY 4	QTY 1	QTY 2	QTY 2	QTY 1
12 X 6 APEX COMBI	QTY 2	QTY 2	QTY 4	QTY 1	QTY 4	QTY 2	QTY 1
14 X 6 APEX COMBI	QTY 2	QTY 2	QTY 4	QTY 1	QTY 2	QTY 4	QTY 1

Building Contents:

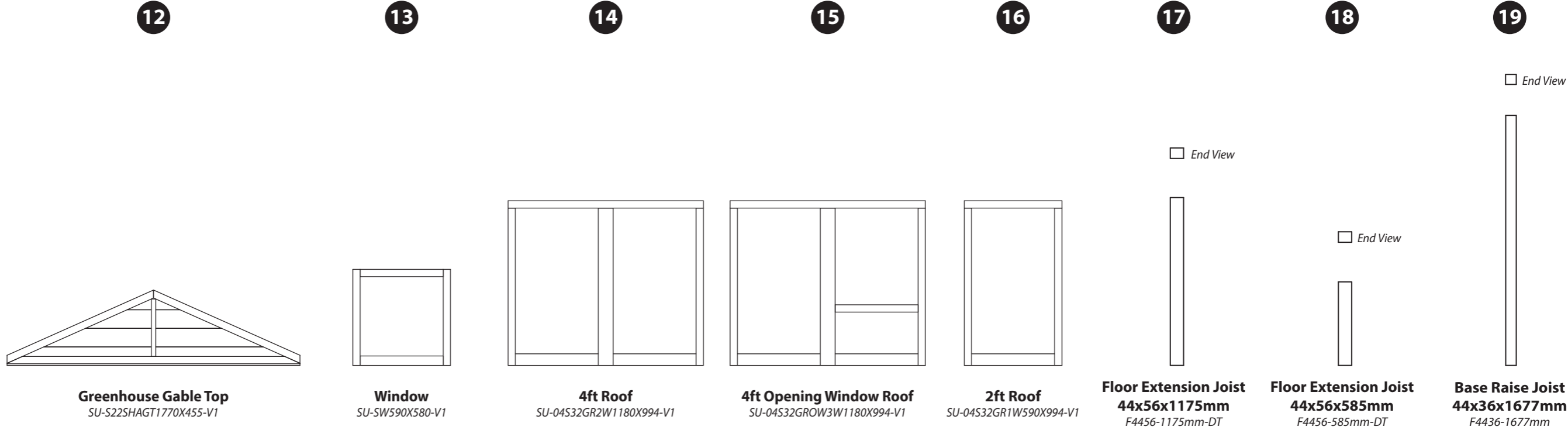

10 X 6 APEX COMBI	QTY 1	QTY 1	QTY 1	QTY 1	-	QTY 2	QTY 2	QTY 2
12 X 6 APEX COMBI	QTY 1	QTY 1	QTY 1	QTY 1	QTY 2	QTY 2	QTY 2	QTY 2
14 X 6 APEX COMBI	QTY 1	QTY 1	QTY 3	QTY 1	-	QTY 2	QTY 2	QTY 2

Building Contents:

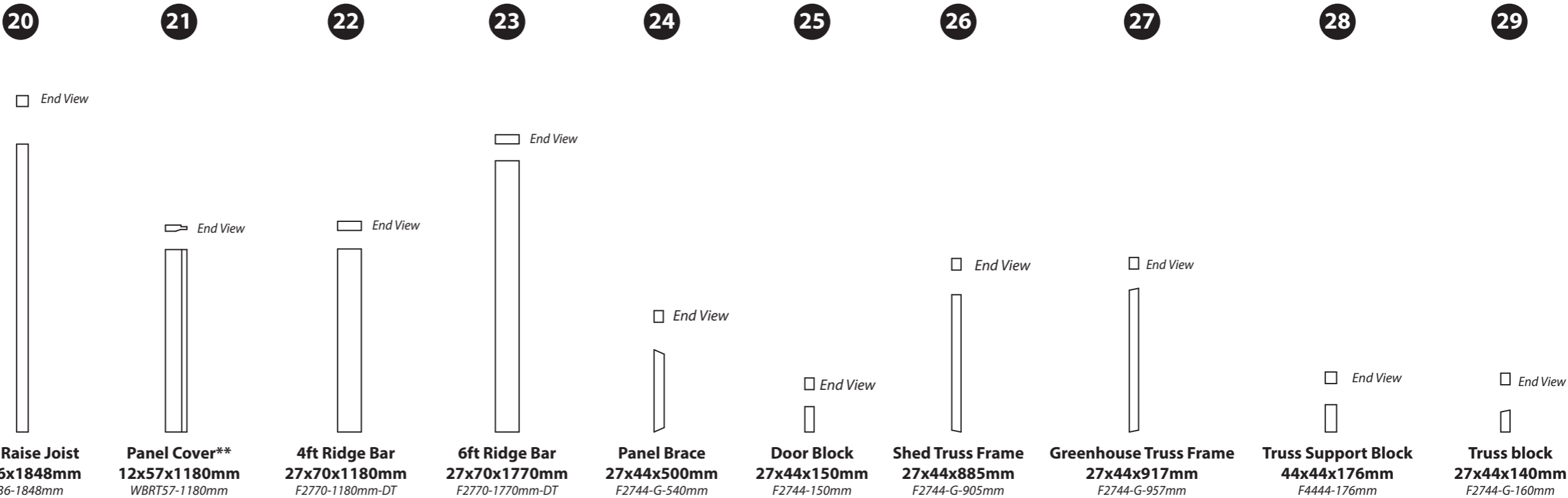

10 X 6 APEX COMBI	QTY 2	QTY 8	QTY 1	QTY 1	QTY 12*	QTY 2	QTY 2	QTY 2	QTY 2*	QTY 2
12 X 6 APEX COMBI	QTY 2	QTY 8	-	QTY 2	QTY 12*	QTY 2	QTY 2	QTY 4	QTY 2*	QTY 4
14 X 6 APEX COMBI	QTY 2	QTY 8	QTY 2	QTY 1	QTY 12*	QTY 2	QTY 2	QTY 4	QTY 2*	QTY 4*

*Included in add on
'Panel Brace kit'
only.*

**You may have more of this part that required.*

****This part will be longer than needed and requires cutting to size when used. This will be explained when required within the instruction step.**

Note: one piece may be required to be cut into multiple different sizes. Do not dispose of off-cuts until the building is fully constructed as they may be needed in another step.

Building Contents:

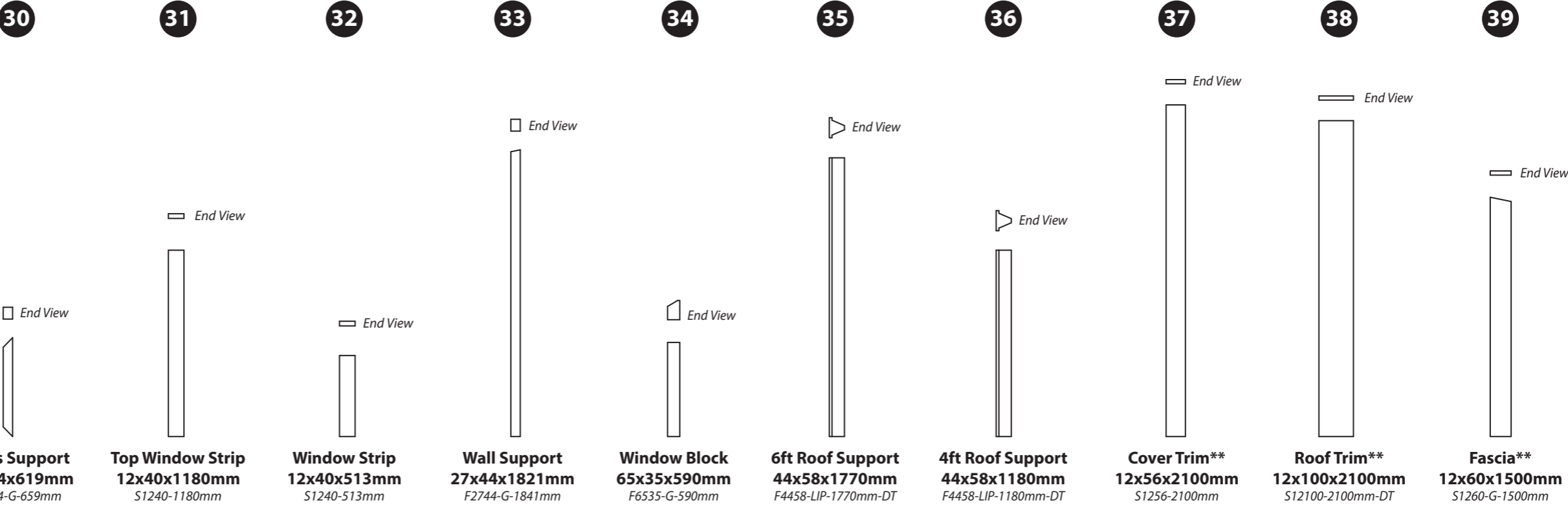

10 X 6 APEX COMBI	QTY 2	QTY 1	QTY 5	QTY 2	QTY 1	-	QTY 1	QTY 18*	QTY 2	QTY 4
12 X 6 APEX COMBI	QTY 3	QTY 1	QTY 5	QTY 2	QTY 1	QTY 1	-	QTY 18*	QTY 2	QTY 4
14 X 6 APEX COMBI	QTY 3	QTY 1	QTY 5	QTY 2	QTY 1	-	QTY 2	QTY 18*	QTY 2	QTY 4

*You may have more of this part that required.

**This part will be longer than needed and requires cutting to size when used. This will be explained when required within the instruction step.

Note: one piece may be required to be cut into multiple different sizes. Do not dispose of off-cuts until the building is fully constructed as they may be needed in another step.

Building Contents:

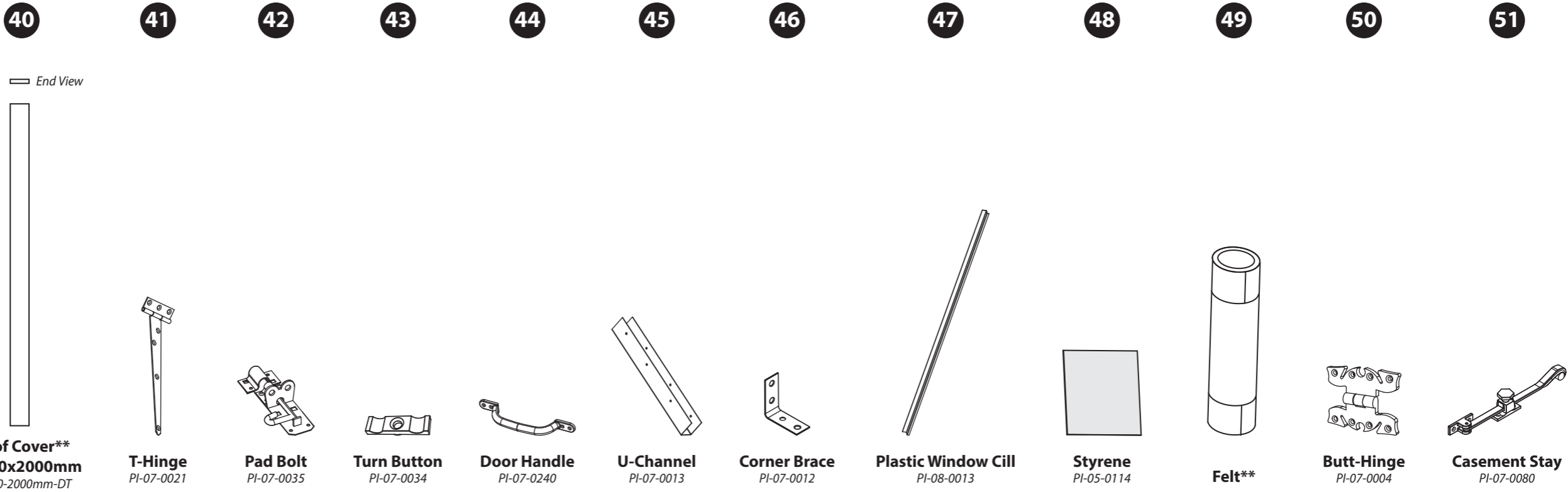

10 X 6 APEX COMBI	QTY 1	QTY 3	QTY 1	QTY 2	QTY 1	-	QTY 4	QTY 1	QTY 2	QTY 1	QTY 2	QTY 1
12 X 6 APEX COMBI	QTY 1	QTY 3	QTY 1	QTY 2	QTY 1	-	QTY 4	QTY 1	QTY 2	QTY 1	QTY 2	QTY 1
14 X 6 APEX COMBI	QTY 2	QTY 3	QTY 1	QTY 2	QTY 1	QTY 1	QTY 4	QTY 1	QTY 2	QTY 1	QTY 2	QTY 1

****This part will be longer than needed and requires cutting to size when used. This will be explained when required within the instruction step.
 Note: one piece may be required to be cut into multiple different sizes. Do not dispose of off-cuts until the building is fully constructed as they may be needed in another step.**

Building Contents:

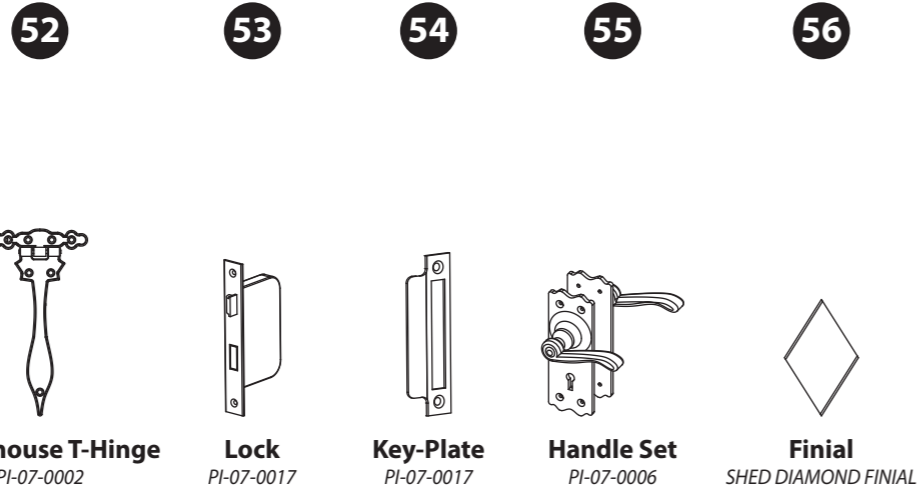

	52	53	54	55	56
10 X 6 APEX COMBI	QTY 3	QTY 1	QTY 1	QTY 1	QTY 2
12 X 6 APEX COMBI	QTY 3	QTY 1	QTY 1	QTY 1	QTY 2
14 X 6 APEX COMBI	QTY 3	QTY 1	QTY 1	QTY 1	QTY 2

Screw Packs

In the table below, please refer to the row with your chosen building size and type in to determine how many of each screw is required.

There may be extra screws in the pack.

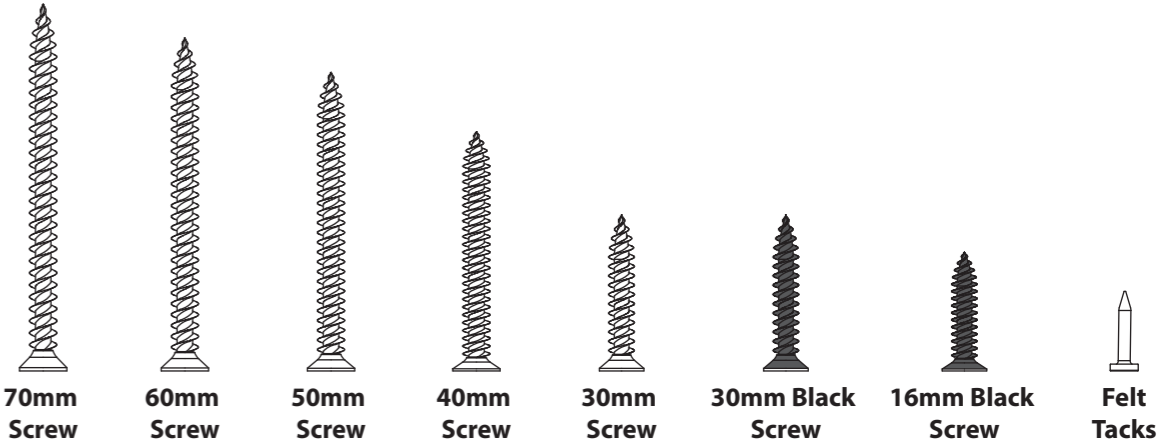

	70mm Screw	60mm Screw	50mm Screw	40mm Screw	30mm Screw	30mm Black Screw	16mm Black Screw	Felt Tacks
10 X 6 APEX COMBI	QTY 28	QTY 56	QTY 100	QTY 74	QTY 165	QTY 51	QTY 4	QTY 100
12 X 6 APEX COMBI	QTY 42	QTY 62	QTY 118	QTY 78	QTY 177	QTY 51	QTY 4	QTY 100
14 X 6 APEX COMBI	QTY 46	QTY 62	QTY 126	QTY 78	QTY 190	QTY 51	QTY 4	QTY 100



Missing parts?

Scan the QR code to visit our customer portal where you can quickly raise any missing or damaged parts and get a replacement sent out ASAP.



Before assembly, please make sure you have a suitable base ready to install your building onto.

Pre-Assembly

		Parts Needed				
Building		No. 4a	No. 4c	No. 5	No. 24	40mm screw
All sizes		QTY 1	QTY 2	QTY 4	QTY 10	QTY 20

If you have not purchased a 'Panel Brace' add-on kit, please skip to step 1.

Please note: You have been supplied with 12 Panel Braces (No. 24) however you may only need to use 10.

Place the 4ft Window Panel (No. 4a), 4ft Plain Panels (No. 4c) and 2ft Plain Panels (No. 5) face down on a flat and level base.

At the bottom of each panel, locate the Panel Braces (No. 24) onto the internal cladding of the panels and up to the framing, ensuring the framing is flush and level, as shown.

****Tip: To identify the bottom of the panel, look for where the cladding overhangs past the framing. This is the bottom of the panel.**

The 4ft Panels (No. 4a & 4c) should have two braces per panel and the 2ft Panels (No. 5) should have one brace per panel, as shown.

Secure the Braces (No. 24) in place by screwing through the outside of the panel framing into the brace behind using 1x40mm screw per end, as shown.

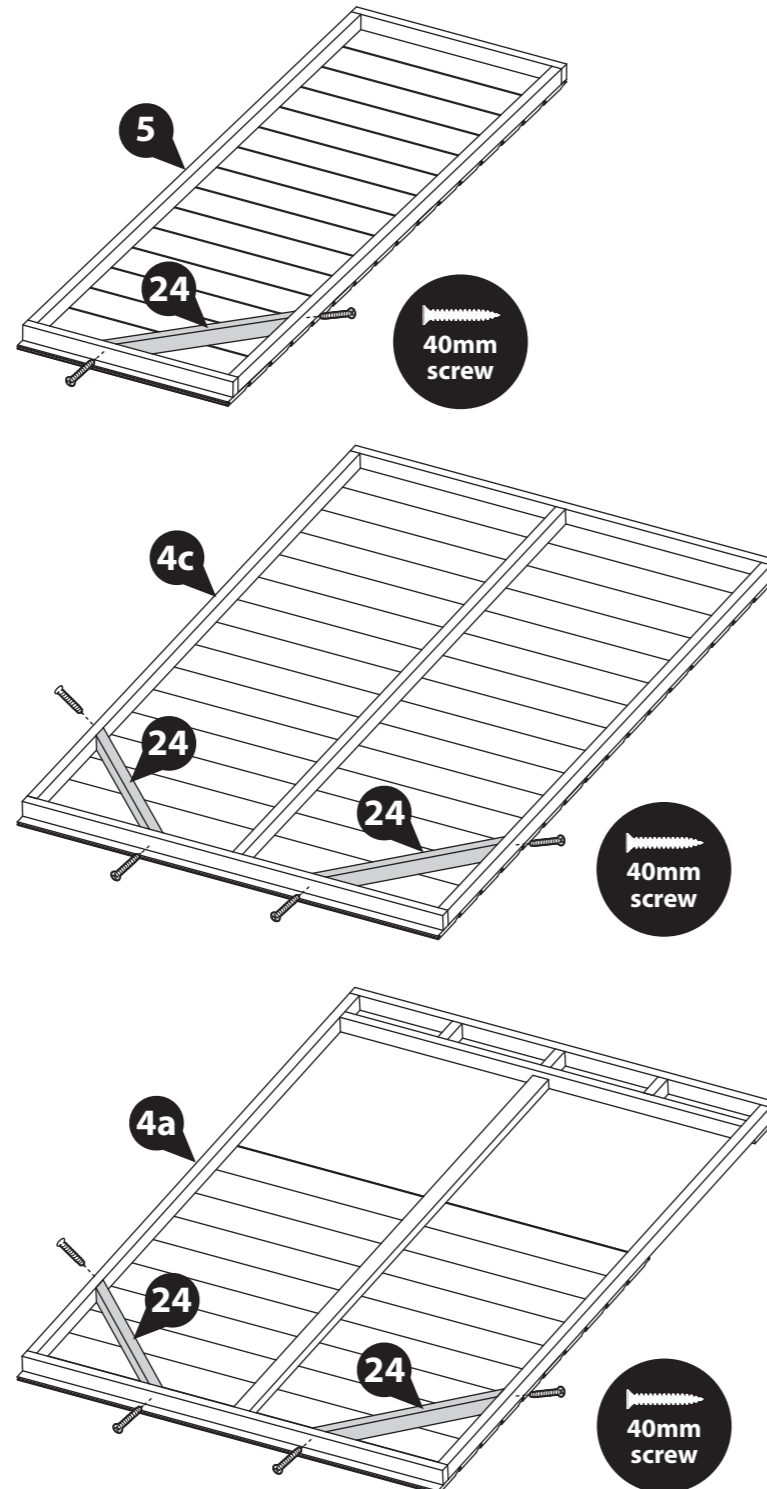

IMPORTANT: Pre-drill before fixing screws.

Step 1

		Parts Needed			
Building		No. 3	No. 4b	No. 41	30mm screw
All sizes		QTY 1	QTY 1	QTY 3	QTY 21

Place the 4ft Door Panel (No. 4b) face up onto a flat and level base.

Place the Door (No. 3) within the 4ft Door Panel (No. 4b), ensuring there is equal spacing on each side.

Locate the T Hinges (No. 41) onto the Door and Door Panel, ensuring the hinge lines up with the framing on the inside of the Door.

Secure in place using 7x30mm screws per hinge, ensuring that the screws go through the cladding and into the framing behind.

****PLEASE NOTE**** Before fitting the hinges, ensure the Door is in the correct position depending on which side you want the Door to open. See the illustrations below which show the Door's internal framing.

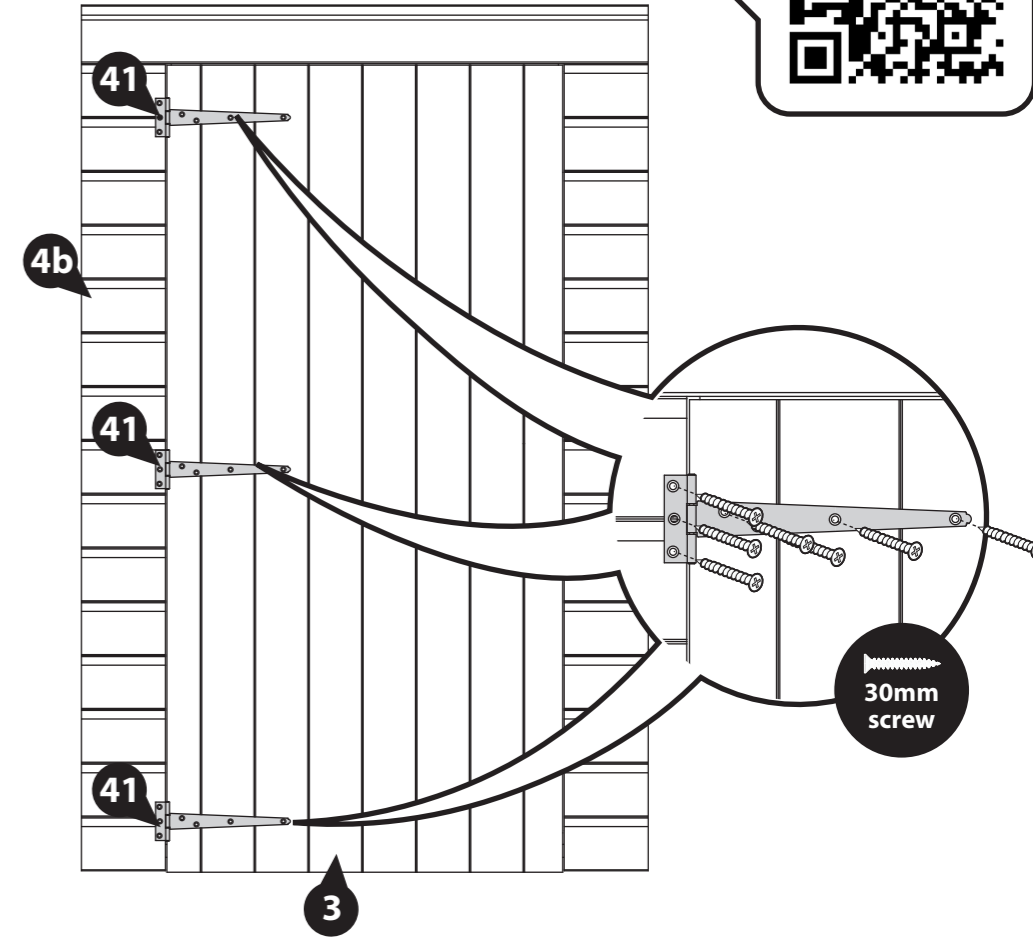

IMPORTANT: Pre-drill before fixing screws.



Opens from the Left

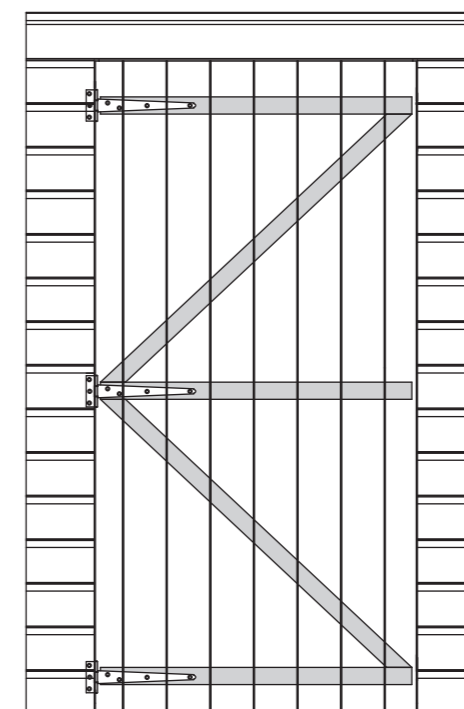

Opens from the Right

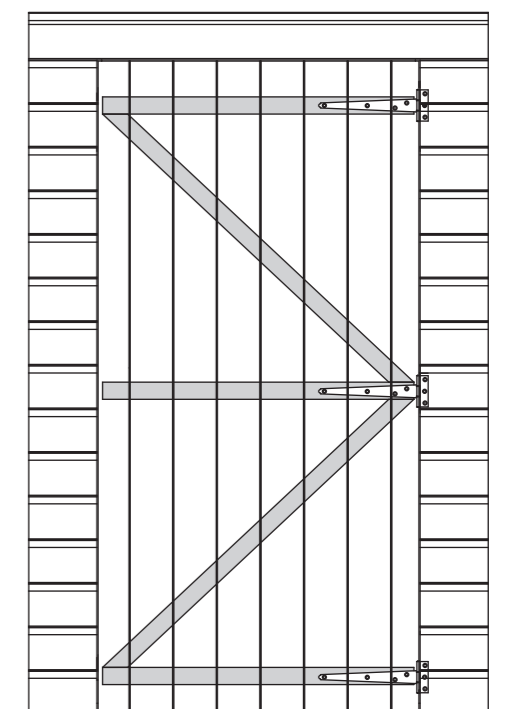

Step 2

Parts Needed

Building	No. 3	No. 25	30mm screw
All sizes	QTY 1	QTY 2	QTY 4

Please note: Your Handle can be positioned horizontally or vertically. Please decide which works best before fitting your door blocks. Follow the relevant step below depending on your choice.

Position one Door Block (No. 25) horizontally underneath the central piece of framing on the Door (No. 3), ensuring the ends and sides are flush.

Ensuring to support the Block, secure in place using 2x30mm screws, screwing through the outside of the Door cladding into the block behind.

Horizontal handle:

Locate the second Door Block (No. 25) on the top of the central piece of framing, on the opposite side to the already fitted block. Ensuring the ends and sides are flush, secure in place using 2x30mm screws, screwing through the outside of the Door cladding into the block behind.

Vertical handle:

Locate the second Door Block (No. 25) vertically on the top of the central piece of framing, on the opposite side to the already fitted block. Ensuring the ends and sides are flush, secure in place using 2x30mm screws, screwing through the outside of the Door cladding into the block behind.

IMPORTANT: Pre-drill before fixing screws.

Horizontal Handle:

Opens from the Left

Opens from the Right

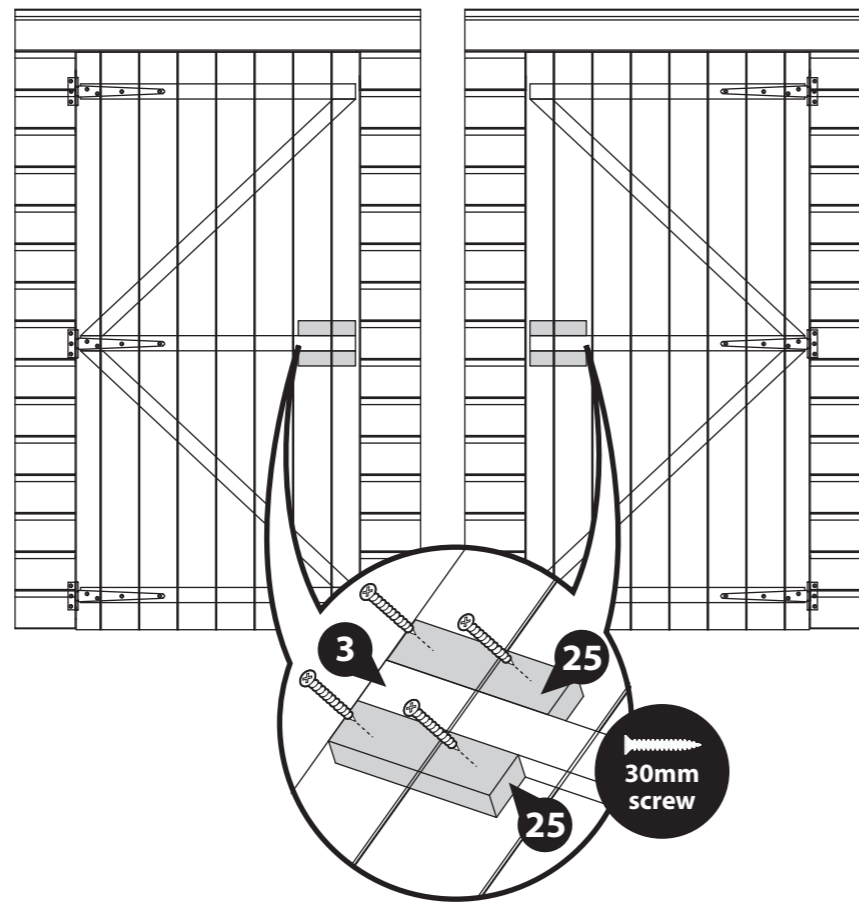

Vertical Handle:

Opens from the Left

Opens from the Right

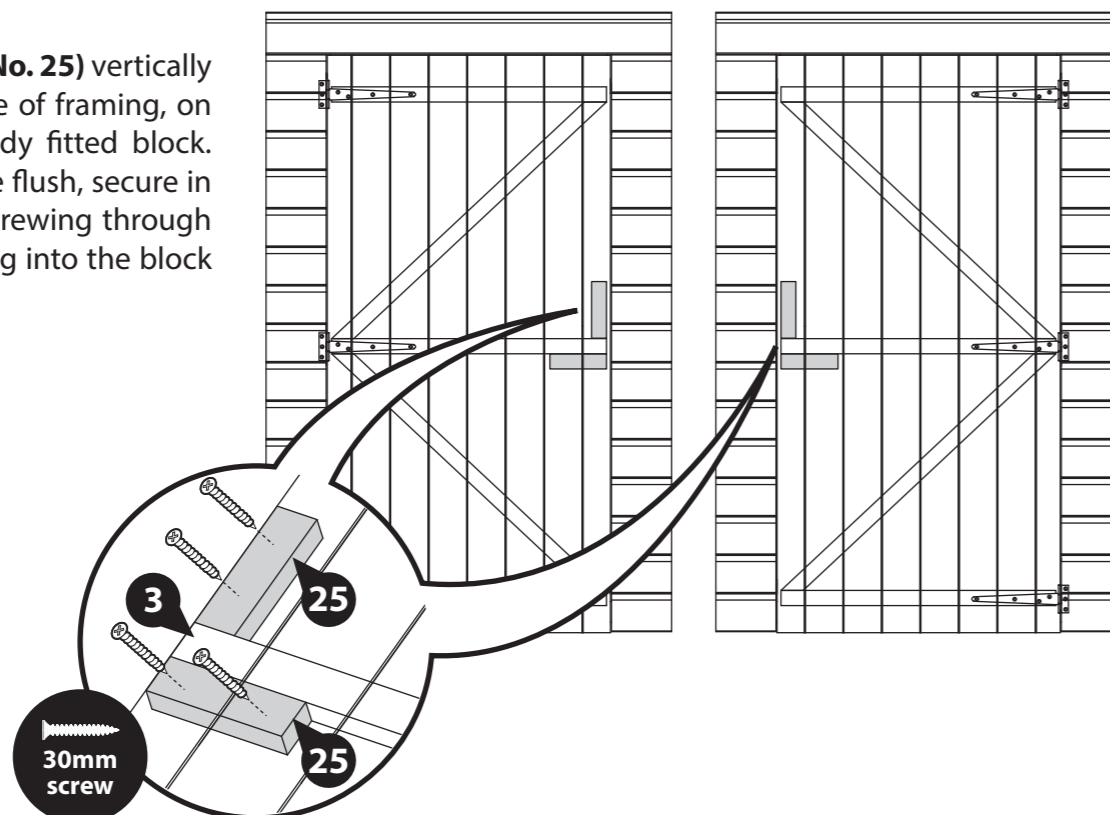

Step 3

Parts Needed

Building	No. 42	30mm screw
All sizes	QTY 1	QTY 10

Locate the Pad Bolt (No. 42) onto the Door (No. 3) ensuring to line it up with the bottom internal door block, and the retainer to the 4ft Door Panel (No. 4b).

Fix in place using 10x30mm screws. Ensure to screw through the cladding into the framing block behind.

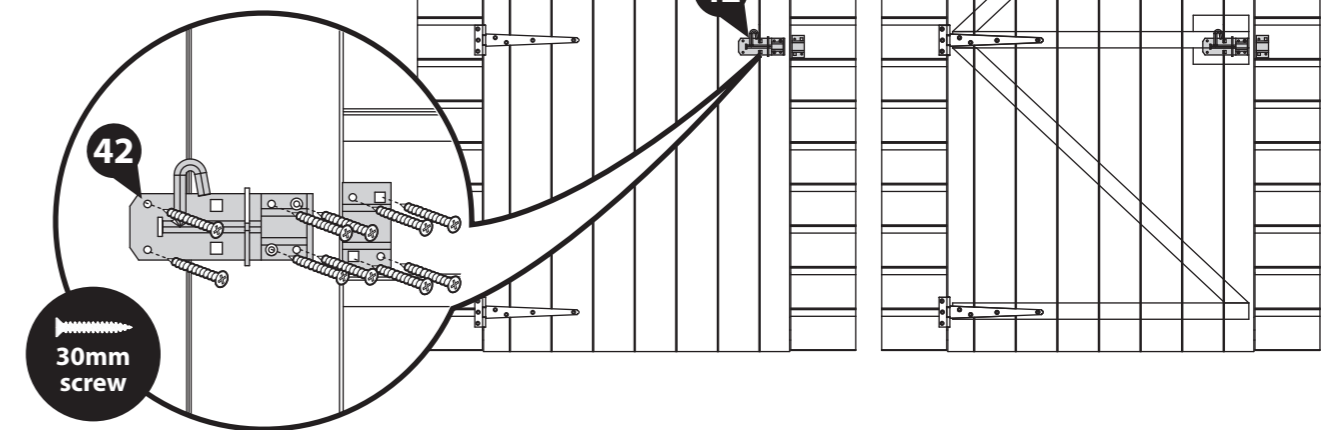

IMPORTANT: Pre-drill before fixing screws.

Internal door framing

Step 4

Parts Needed

Building	No. 43	30mm screw
All sizes	QTY 2	QTY 2

Position a Turn Button (No. 43) to the top and bottom of the 4ft Door Panel (No. 4b) and fix in place using 1x30mm screw per turn button.

Ensure the Turn Buttons rotate to sit across the Door and the Door Panel, as these will help to hold the Door shut.

These Turn Buttons help to keep your Doors straight during high and low levels of moisture content in the air.

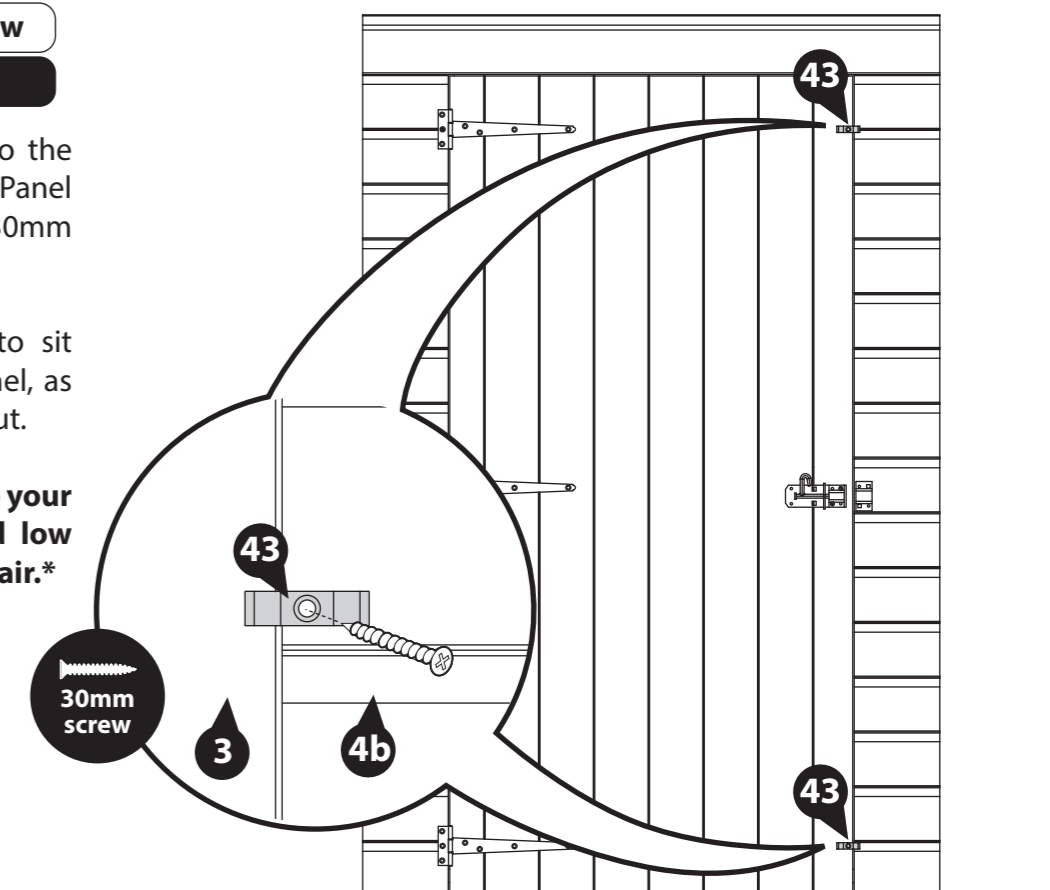

Step 5

Parts Needed

Building	No. 44	30mm screw
All sizes	QTY 1	QTY 4

Please note: Your Handle can be positioned horizontally or vertically. Please decide which works best before fitting.

Locate the Handle (**No. 44**) onto the Door (**No. 3**) so it sits just above the previously fitted Pad Bolt, ensuring to line it up with the internal door blocks.

Secure in place using 4x30mm screws. Ensure to screw through the handle and cladding into the framing block behind.

Horizontal Handle:

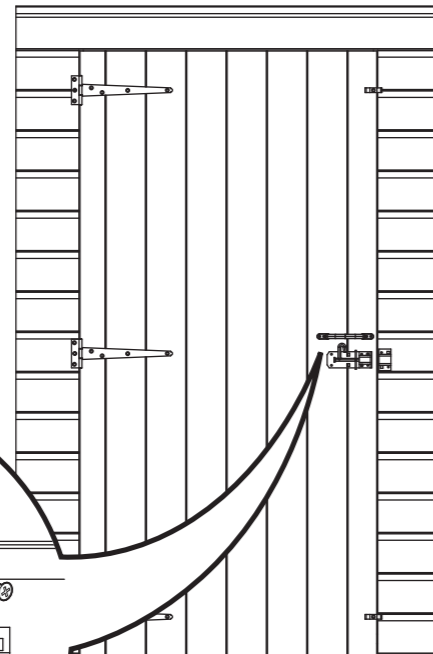

Internal door framing

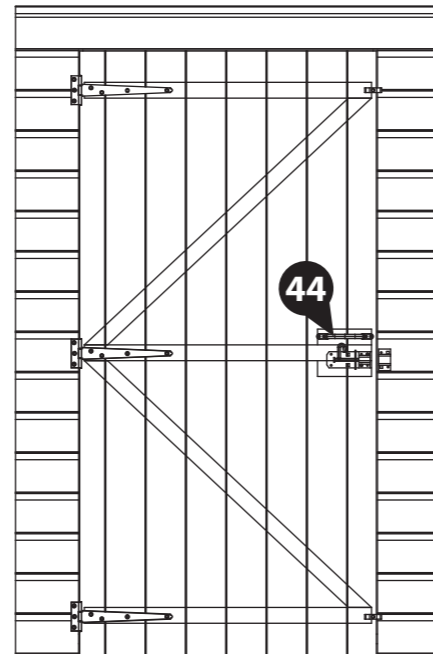

Vertical Handle:

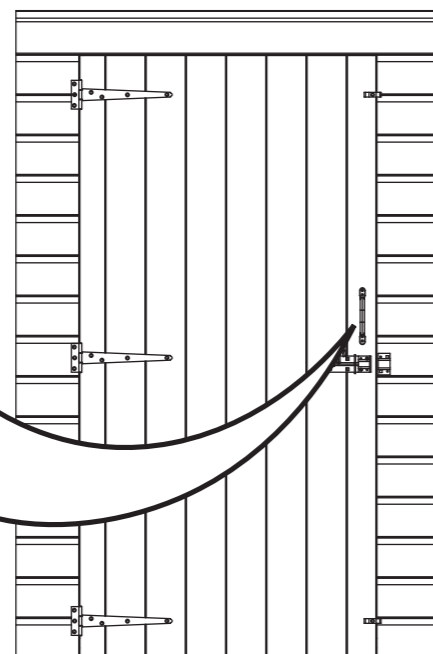

Internal door framing

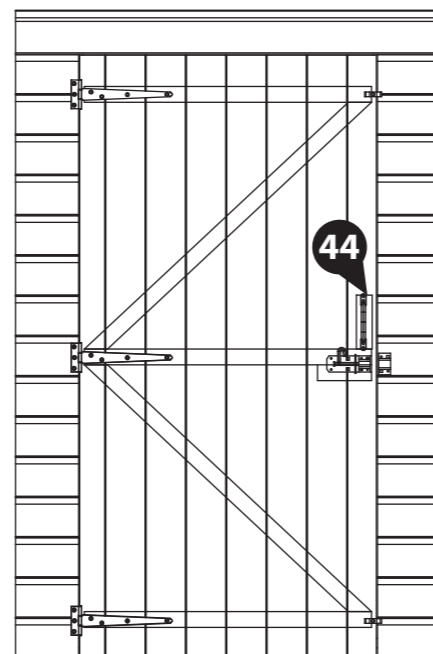

IMPORTANT: Pre-drill before fixing screws.

Step 6

Parts Needed

Building	No. 1	No. 2	50mm screw
All sizes	QTY 1	QTY 1	QTY 6

Place the Floor Panels (**No. 1 & 2**) face down onto a firm and level base.

Push the Floor Panels together so the bearers are flush and level, as shown.

Secure the Floors together using 6x50mm screws, screwing through the bearers in an alternating pattern.

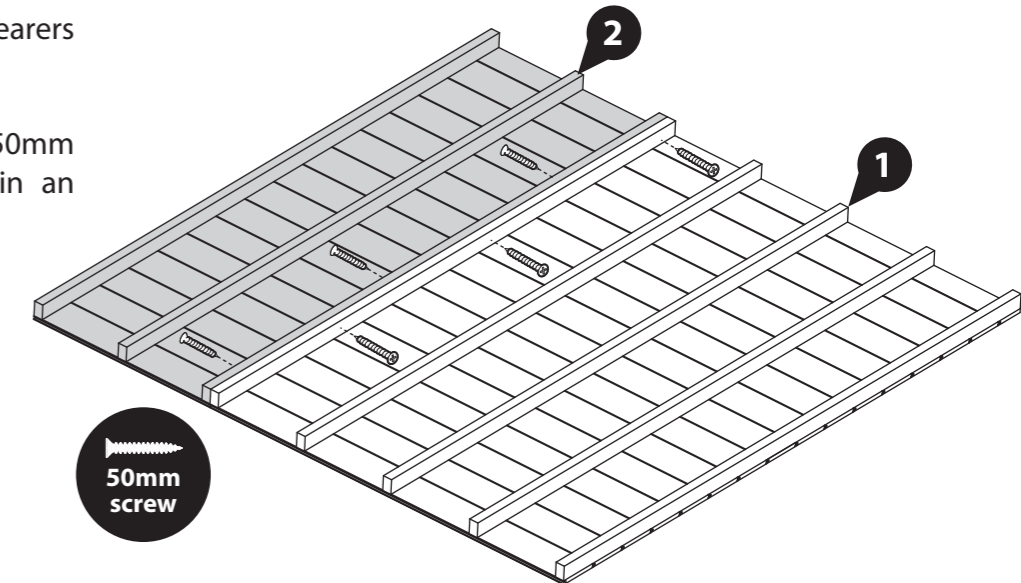

Step 7

Parts Needed

Building	No. 1	No. 2	No. 17	No. 18	60mm screw
All sizes	QTY 1	QTY 1	QTY 2	QTY 2	QTY 12

Locate one of each Floor Extension Joist (**No. 9 & 10**) onto either end of the assembled Floor Panels. Ensure the joists are flush to each other and to the Floor Panel framing, as shown.

Position the Floor joists centrally to the Floor Panel framing.

Secure the joists to the Floor Panels using 3x60mm screws per joist, screwing through the joist into the bearers behind.

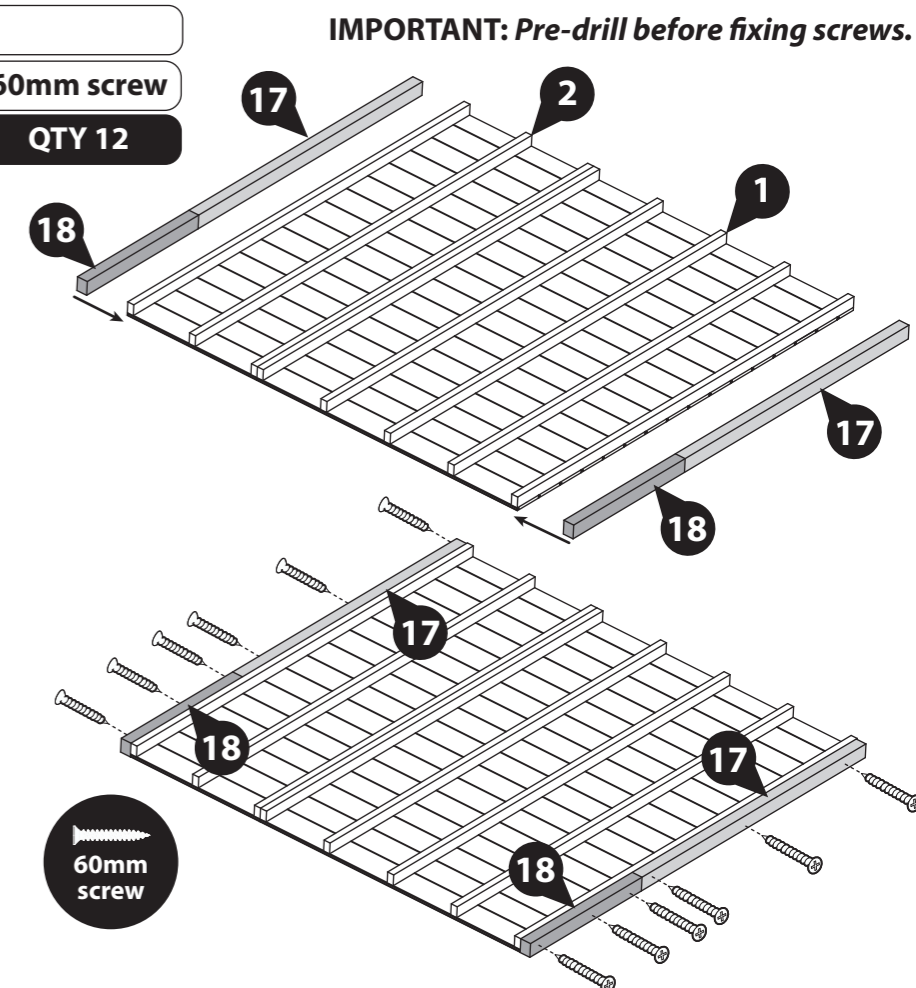

Step 8

Once assembled, flip the assembled Floor Panel (No. 1 & 2) over so the bearers are flat on your firm and level base.

Ensure the base has suitable drainage, free from areas where standing water can collect.

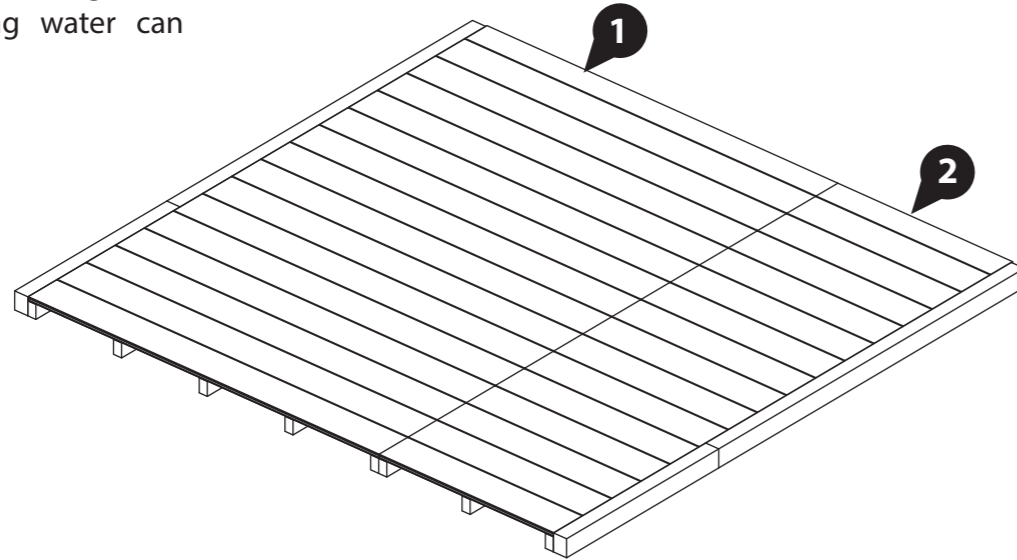

IMPORTANT: Pre-drill before fixing screws.

Step 9

Parts Needed

Building	No. 19	No. 20	60mm screw
All sizes	QTY 2	QTY 2	QTY 16

Place the Base Raise Joists (No. 19 & 20) on top of the Floor, as shown. Ensure the Base Raise Joist (No. 19) sits on the inside of Joist (No. 20) and the joists are flush and level with the edges of the Floor.

Position the joists so the 36mm edge is positioned as the height, and the 44mm is positioned as the width, as shown.

Please ensure the joists are positioned correct, or your shed and greenhouse will NOT align correctly.

Secure the joists to the Floors using 4x60mm screws per Joist, screwing down through the joist into the Floor bearers below.

Ensure the base is square by measuring from corner to corner. If the measurements are the same, the base is level. If not, unscrew and adjust.

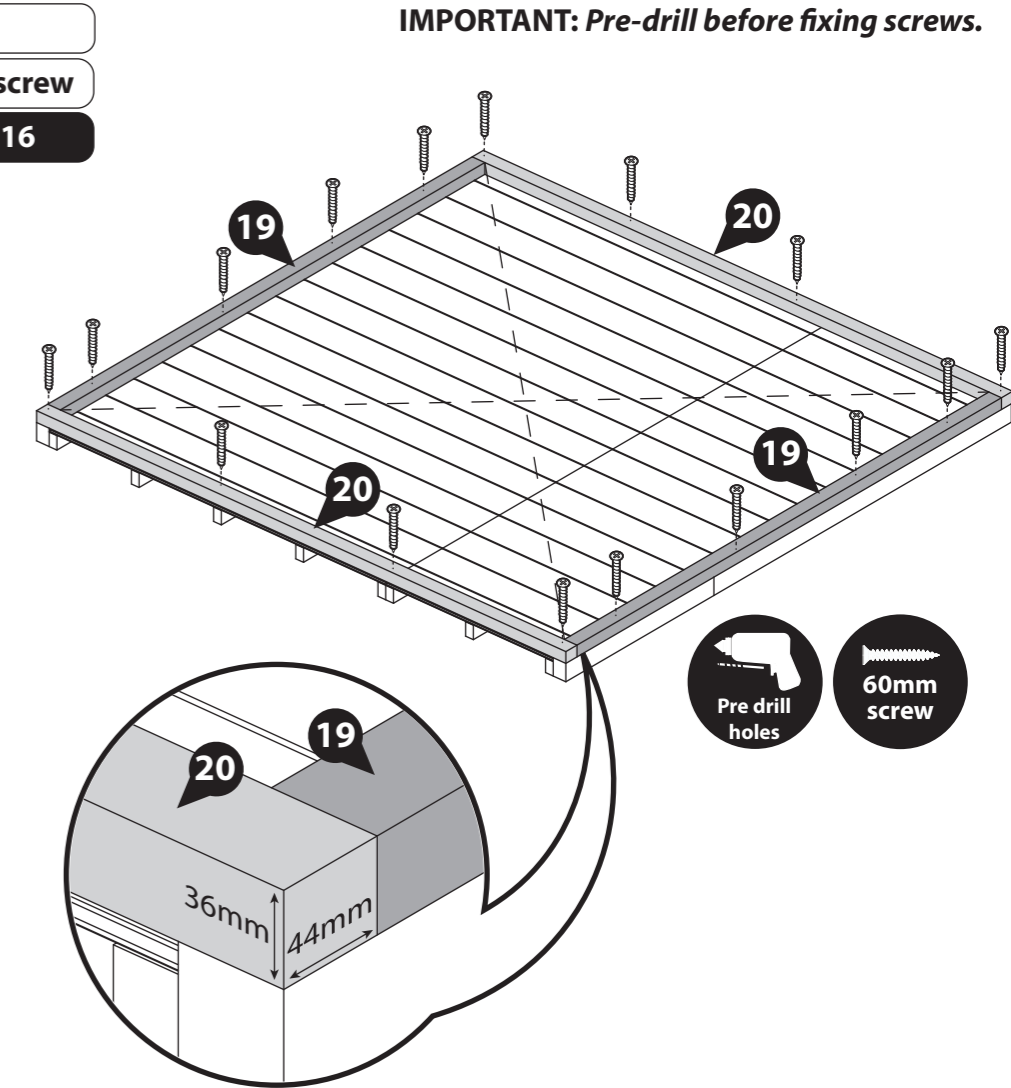

Step 10

Before assembling the shed walls, decide how you want your interchangeable Panels to sit. See Page 5-7 for some ideas.

It is advised to lay your Panels around the shed floor in the desired positions, an example is shown below.

Please note: the 'Greenhouse door on the end, shed door on the inside' configuration has been shown for illustrative purposes and may differ from your chosen configuration. However the process of laying out the Panels is the same.

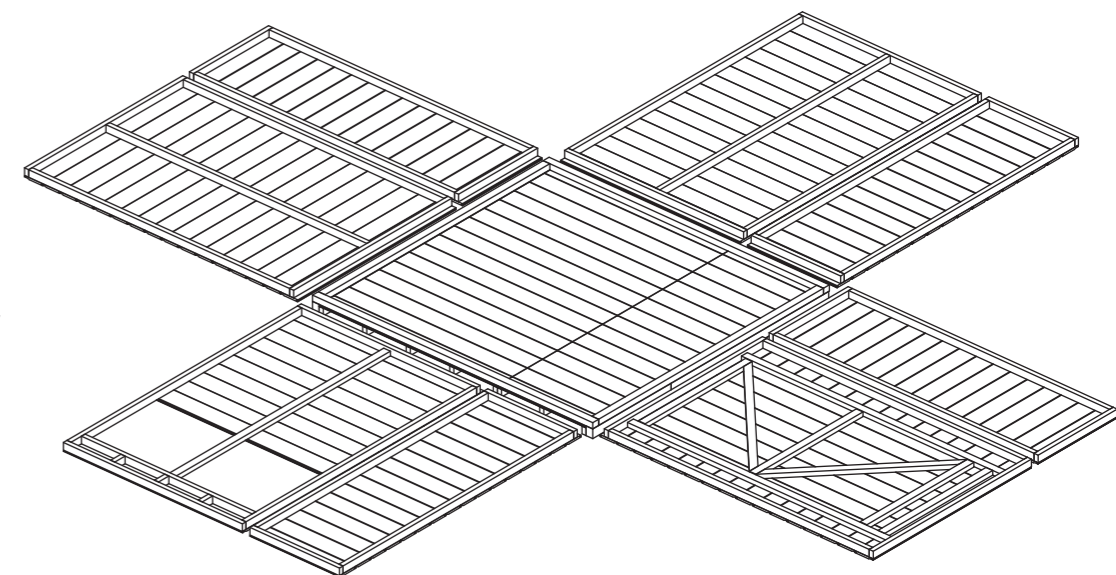

Step 11

Parts Needed

Building	No. 4 (a, b or c)	No. 5	50mm screw
All sizes	QTY 1	QTY 1	QTY 3

****Please note: The 4ft Panels (No. 4a, 4b and 4c) are all interchangeable and can be positioned in a variety of different configurations. Decide which works best before assembly. See Pages 5-7 for some suggested options.****

Locate a 2ft Plain Panel (No. 5) on top of the Base framing at one end.

Locate a 4ft Panel (No. 4a, 4b or 4c) next to the 2ft Panel on the corner, ensuring the 4ft Panel sits on the inside of the 2ft Panel, as shown. Externally, the Panel's framing should sit flush and the cladding should sit proud, as shown in the diagram.

Secure the Panels together at the corner using 3x50mm screws.

Ensure to position the Panels so there is a small gap between the edge of the Floor and the Panel cladding on all sides.

****Please note: if you have purchased a Panel Brace add-on kit, then you may need to secure the panels together higher up to avoid colliding with the brace and screws.**

****Do not secure the building to the Floor until the Roof has been fitted.**

Please note: the 'Greenhouse door on the end, shed door on the inside' has been shown for illustrative purposes and may differ from your chosen configuration. However the process of fitting the Panels is the same.



a

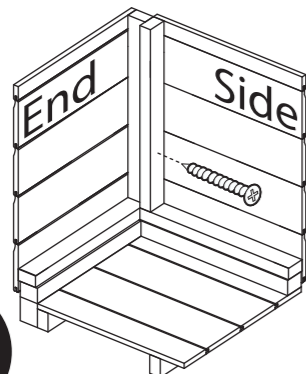

Standard Panels

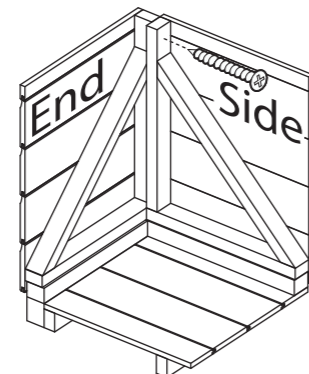

Panel brace kit ONLY

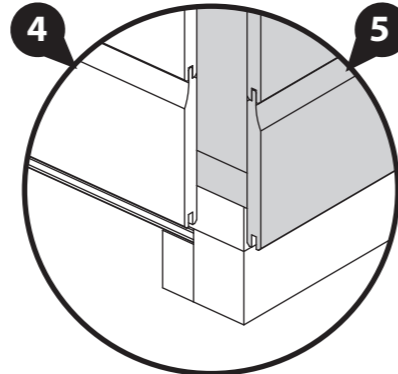

External Corners

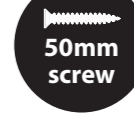

IMPORTANT: Pre-drill before fixing screws.

Step 12

Parts Needed

Building	No. 4 (a, b or c)	No. 5	50mm screw
All sizes	QTY 1	QTY 1	QTY 6

Locate a 2ft Panel (No. 5) next to the 4ft Panel (No. 4a, 4b or 4c) placed in the previous step. Secure the Panels together using 3x50mm screws.

Locate a 4ft Plain Panel (No. 4a, 4b or 4c) next to the 2ft Panel (No. 5) placed in the previous step. Secure the Panels together using 3x50mm screws, screwing through the Panel framing.

Ensure to position the Panels so there is a small gap between the edge of the Floor and the Panel cladding on all sides.

****Please note: if you have purchased a Panel Brace add-on kit, then you may need to secure the panels together higher up to avoid colliding with the brace and screws.**

****Do not secure the building to the Floor until the Roof has been fitted.**

Please note: the 'Greenhouse door on the end, shed door on the inside' has been shown for illustrative purposes and may differ from your chosen configuration. However the process of fitting the Panels is the same.

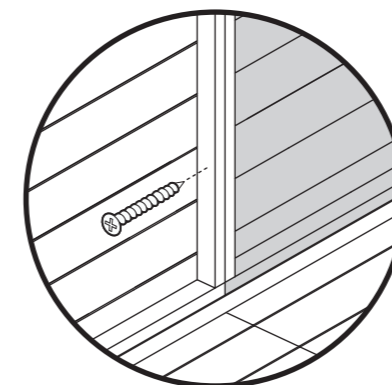

Standard Panels

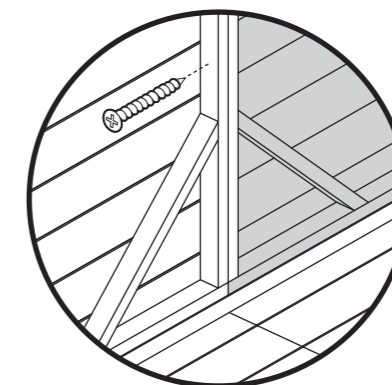

Panel brace kit ONLY

IMPORTANT: Pre-drill before fixing screws.

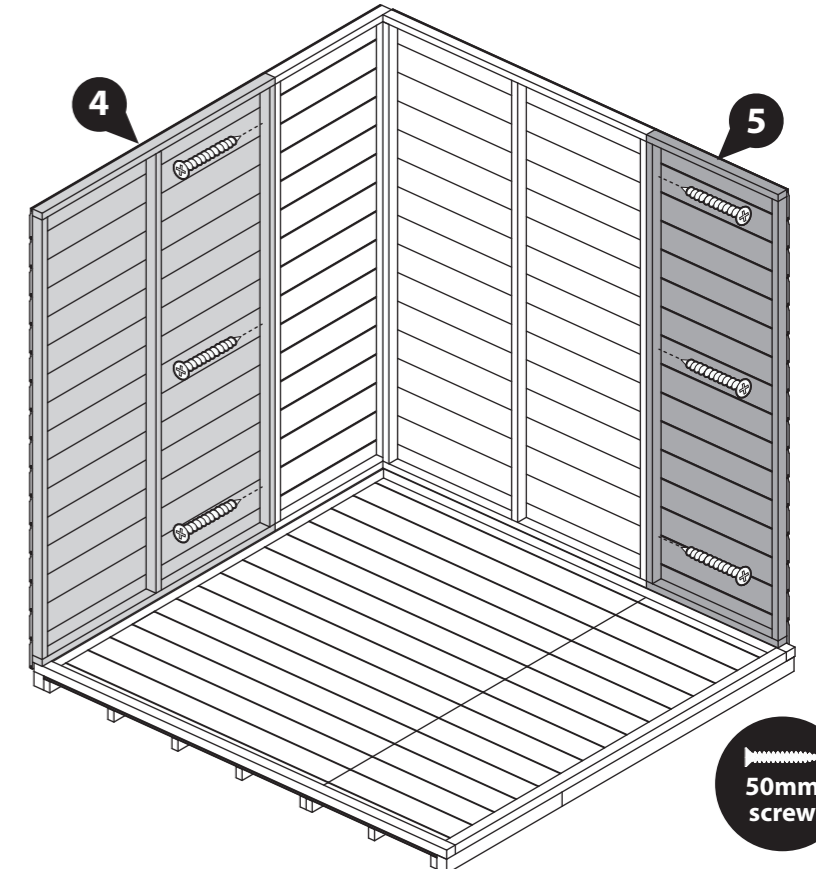

Step 13

Parts Needed

Building	No. 4 (a, b or c)	No. 5	50mm screw
All sizes	QTY 1	QTY 1	QTY 6

At the corner, locate a 2ft Panel (No. 5) onto the end of the previously fitted 2ft Panel, as shown.

On the opposite corner, locate a 4ft Panel (No. 4a, 4b or 4c) onto the inside of the previously fitted 4ft Panel, as shown. Externally, the Panel's framing should sit flush and the cladding should sit proud, as shown in the diagram.

Secure the Panels together using 3x50mm screws.

Ensure to position the Panels so there is a small gap between the edge of the Floor and the Panel cladding on all sides.

****Please note: if you have purchased a Panel Brace add-on kit, then you may need to secure the panels together higher up to avoid colliding with the brace and screws.**

****Do not secure the building to the Floor until the Roof has been fitted.**

Please note: the 'Greenhouse door on the end, shed door on the inside' has been shown for illustrative purposes and may differ from your chosen configuration. However the process of fitting the Panels is the same.

IMPORTANT: Pre-drill before fixing screws.

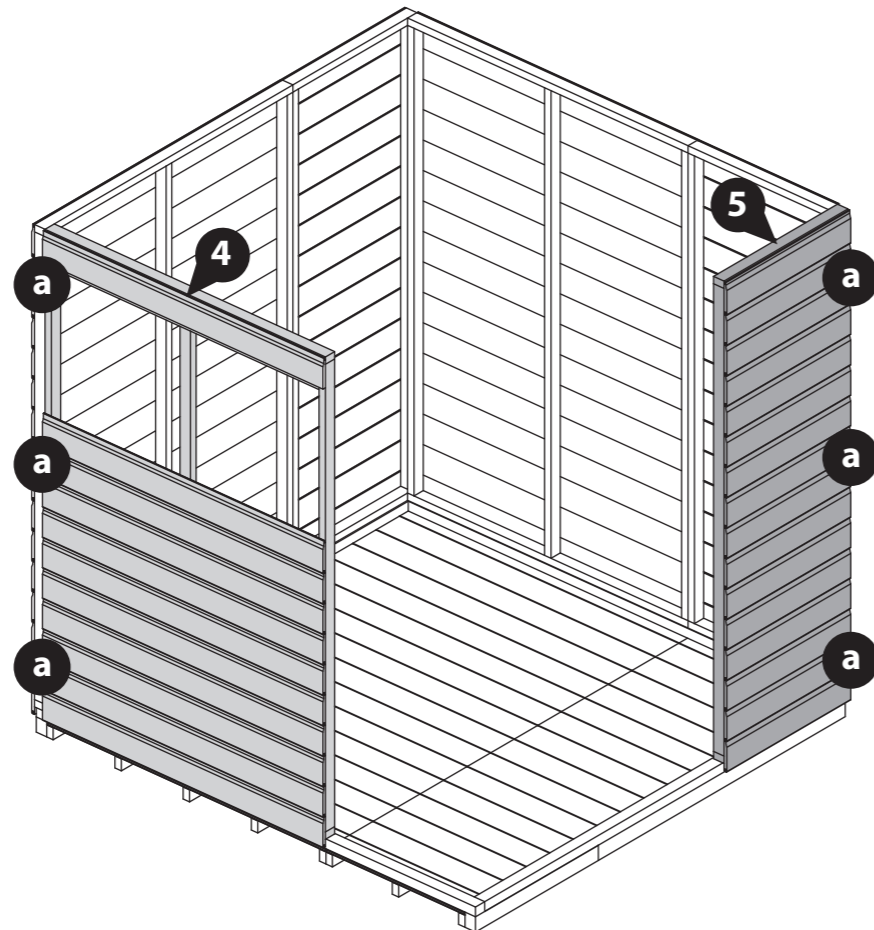

Step 14

Parts Needed

Building	No. 5	50mm screw
All sizes	QTY 1	QTY 3

Locate the remaining 2ft Panel (No. 5) on top of the Floor next to the 4ft Panel (No. 4a, 4b or 4c) fitted in the previous step.

Secure the Panels together using 3x50mm screws.

Ensure to position the Panels so there is a small gap between the edge of the Floor and the panel cladding on all sides.

****Please note: if you have purchased a Panel Brace add-on kit, then you may need to secure the panels together higher up to avoid colliding with the brace and screws.**

****Do not secure the building to the Floor until the Roof has been fitted.**

Please note: the 'Greenhouse door on the end, shed door on the inside' has been shown for illustrative purposes and may differ from your chosen configuration. However the process of fitting the Panels is the same.

IMPORTANT: Pre-drill before fixing screws.

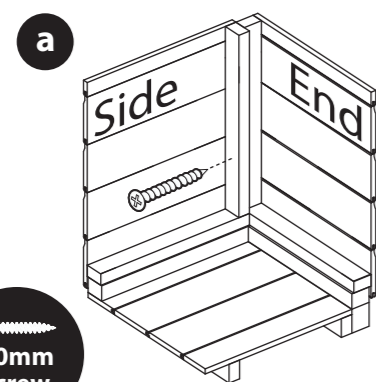
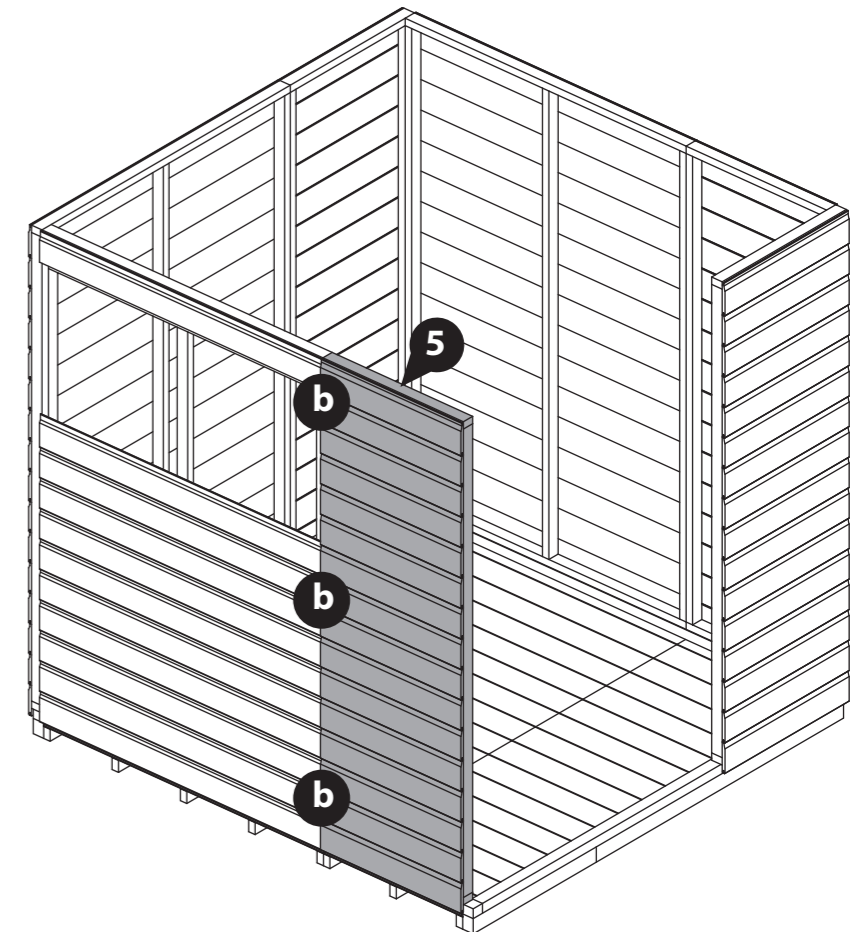

Standard Panels

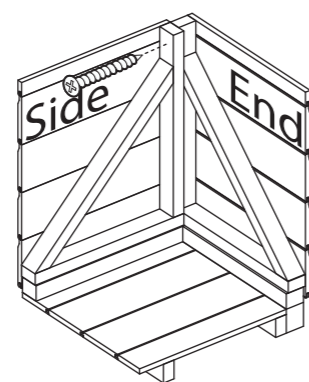

Panel brace kit ONLY

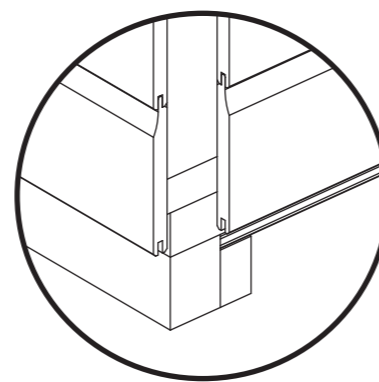

External Corners

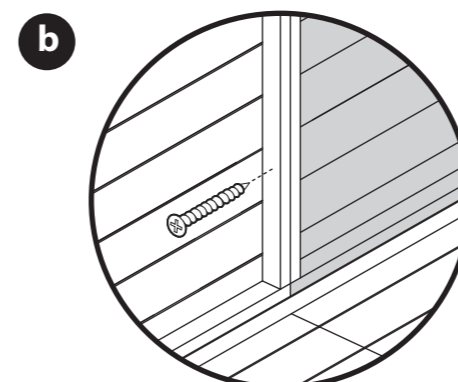

Standard Panels

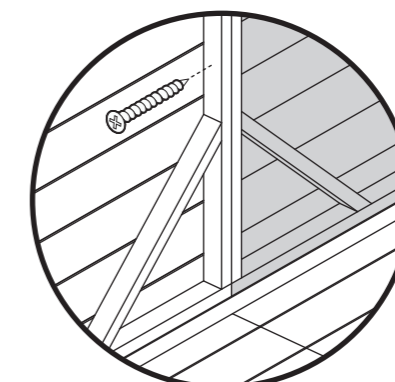

Panel brace kit ONLY



Step 15

Parts Needed

Building	No. 4 (a, b or c)	50mm screw
All sizes	QTY 1	QTY 6

Locate the remaining 4ft Panel (**No. 4a, 4b or 4c**) on top of floor at the end of the 2ft Panel, as shown.

Externally, the Panel's framing should sit flush and the cladding should sit proud, as shown in the diagram.

Fix the Panels together at the corner using 3x50mm screws.

Secure the 4ft Panel to the adjacent 2ft Panel on the other side using 3x50mm screws.

Position the Panels so there is a small gap of equal distance between the edge of the Floor and the Panel cladding on all sides. This allows for the buildings natural movement over time.

****Please note: if you have purchased a Panel Brace add-on kit, then you may need to secure the panels together higher up to avoid colliding with the brace and screws.**

****Do not secure the building to the Floor until the Roof has been fitted.**

Please note: the 'Greenhouse door on the end, shed door on the inside' configuration has been shown for illustrative purposes and may differ from your chosen configuration. However the process of fitting the Panels is the same.

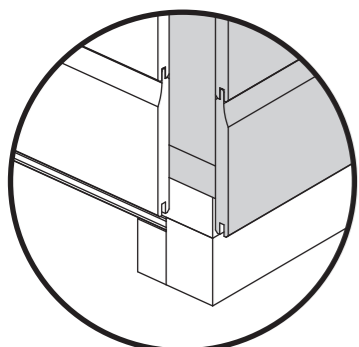

External Corners

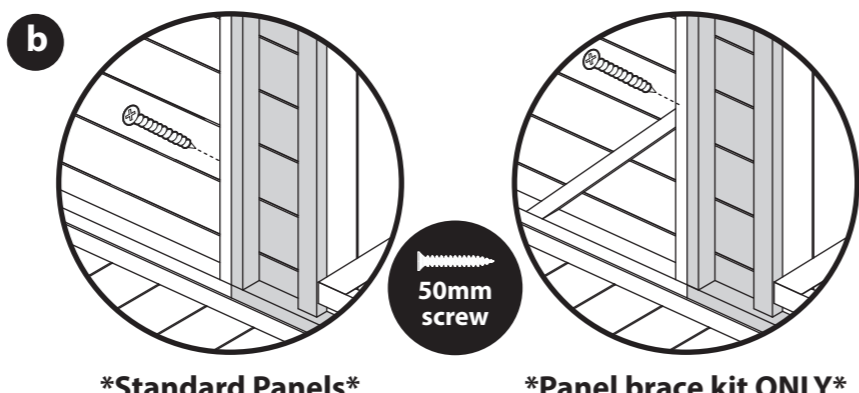
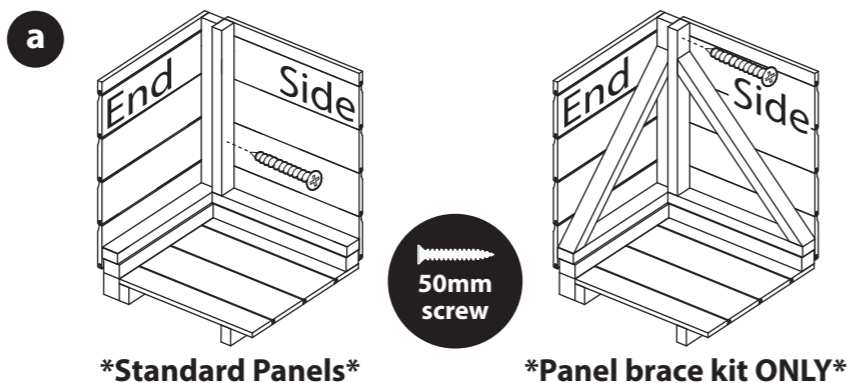
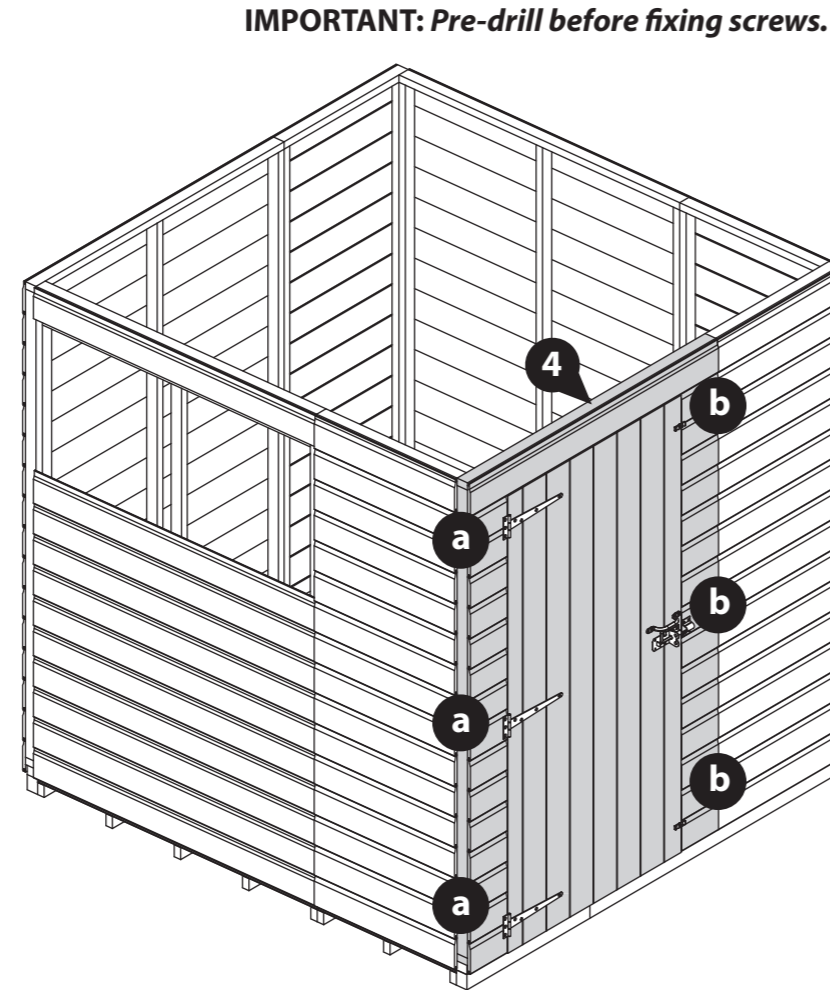

Step 16

Parts Needed

Building	No. 6	50mm screw
All sizes	QTY 2	QTY 10

Locate the Gable Tops (**No. 6**) on top of the end Panels, ensuring that the Gable cladding slots into the top cladding on the Panel below.

Secure in place using 5x50mm screws per Gable, screwing up through the Panel framing into the Gable.

Please note: the 'Greenhouse door on the end, shed door on the inside' configuration has been shown for illustrative purposes and may differ from your chosen configuration. However the process of fitting the Gable Tops is the same.

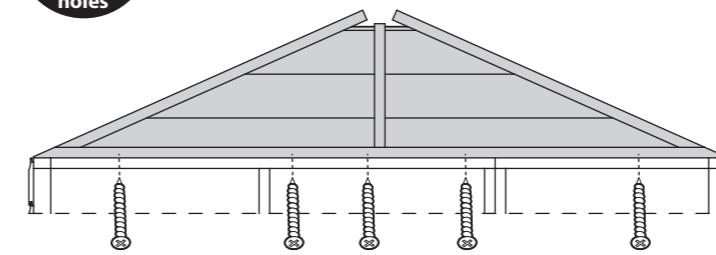

IMPORTANT: Pre-drill before fixing screws.

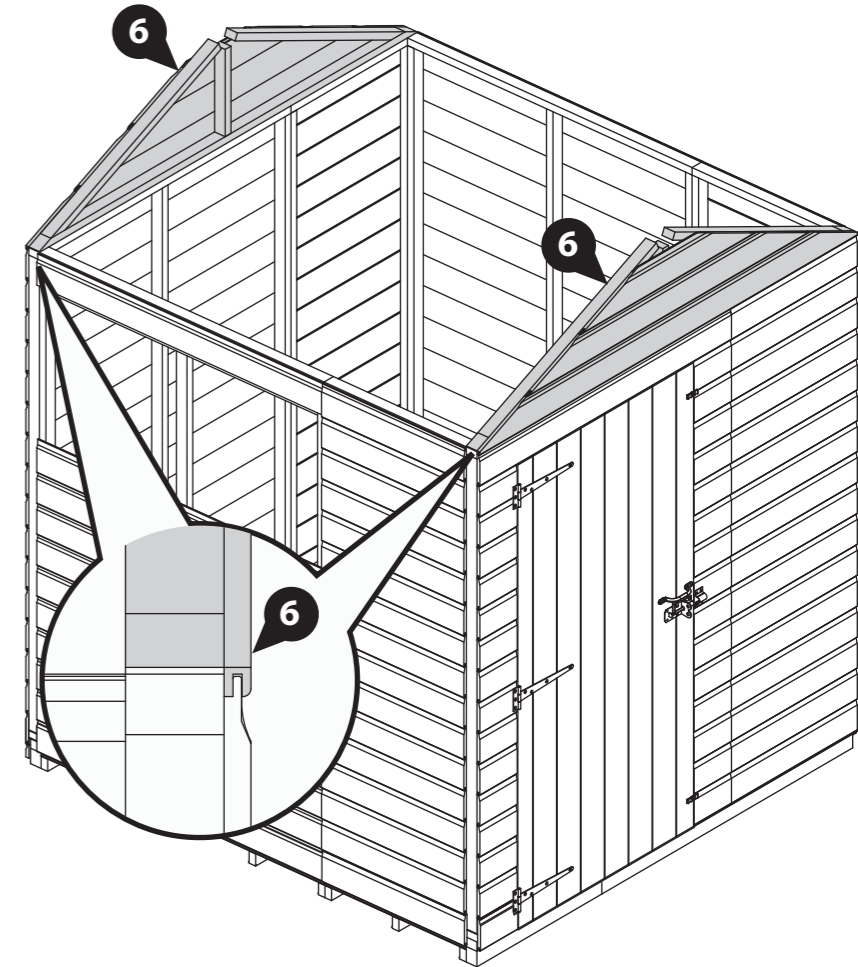

IMPORTANT: Pre-drill before fixing screws.

Step 17

Parts Needed

Building	No. 22	No. 23	No. 45	No. 46	30mm screw
10x6	QTY 1	QTY 1	-	QTY 4	QTY 8
12x6	-	QTY 2	-	QTY 4	QTY 8
14x6	QTY 2	QTY 1	QTY 1	QTY 4	QTY 18

8x6 only:

Position the Ridge Bars (**No. 22**) in a row so the ends are flush together and the faces are level. Position one U-channel (**No. 45**) centrally across each join and secure in place using 10x30mm screws.

All sizes:

Locate one Corner Brace (**No. 46**) onto either end of the Ridge Bars (**No. 22 and/or 23**), ensuring they are flush with the ends of the framing, as shown.

Secure in place using 2x30mm screws per Corner Brace (**No. 46**).

This has constructed your Ridge bars. You should have two assembled Ridge Bars, one for the Shed and one for the Greenhouse, as shown.

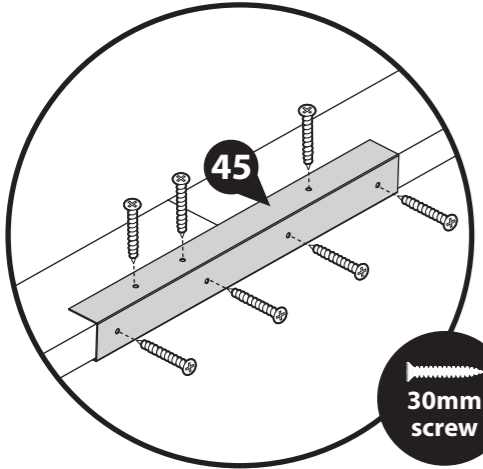

30mm screw

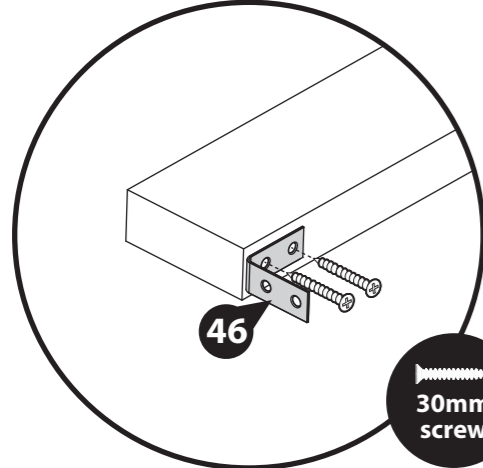

30mm screw

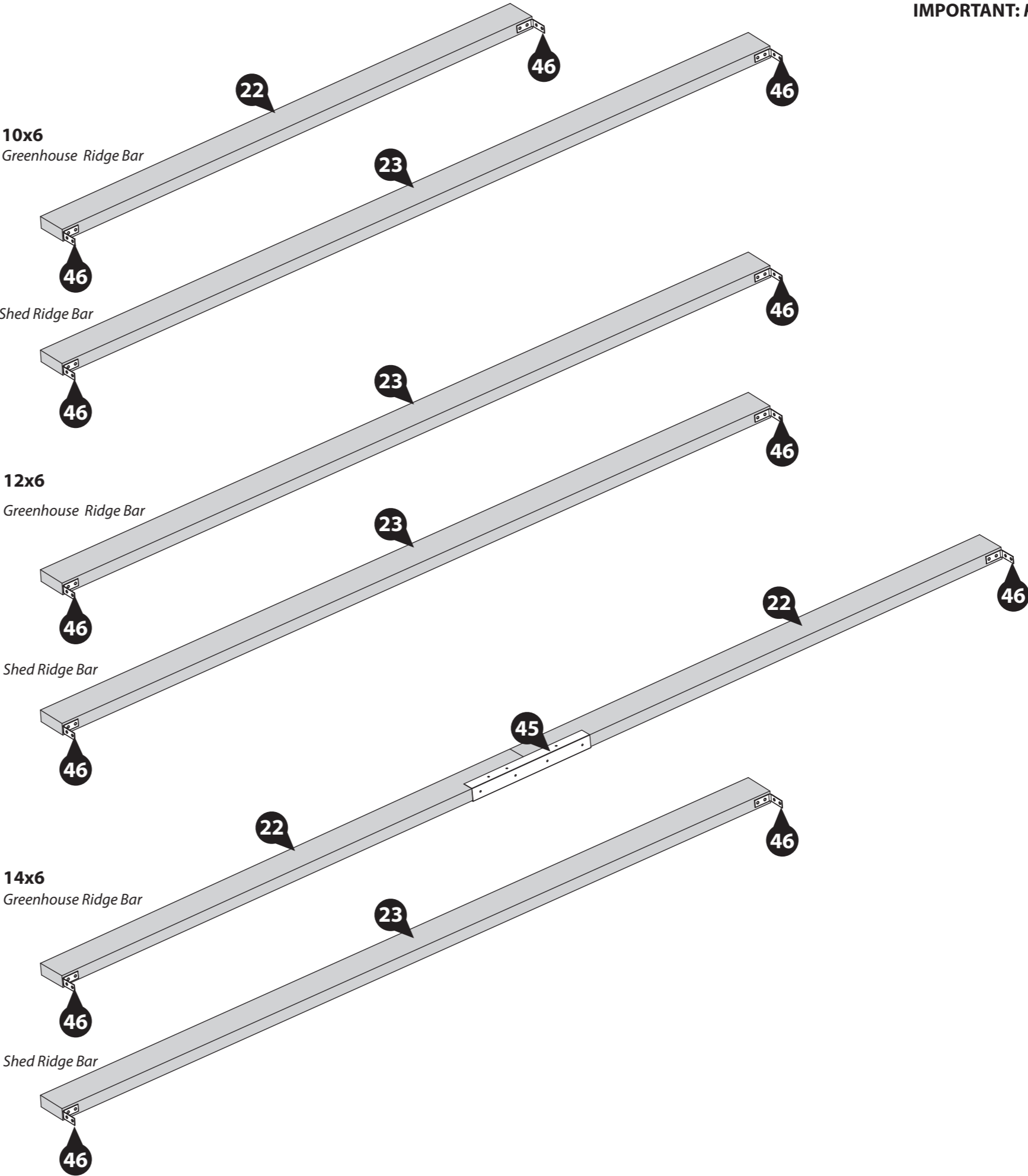

Step 18

Parts Needed

Building	No. 23	No. 46	30mm screw
All sizes	QTY 1	QTY 2	QTY 4

Align the assembled Shed Ridge Bar (**No. 23**) with the central framing of the Gable Tops, ensuring the sides are flush and the top is level.

(If you have not yet assembled your Ridge Bar, please refer to step 17).

Secure the Corner Braces (**No. 46**) to the central upright of the Gable Top using 2x30mm screws per brace.

Please note: the 'Greenhouse door on the end, shed door on the inside' configuration has been shown for illustrative purposes and may differ from your chosen configuration. However the process of fitting the Ridge Bar is the same.

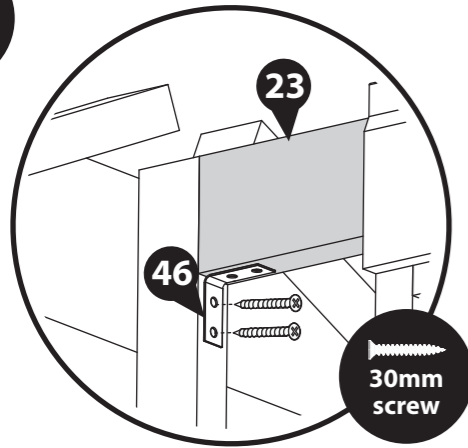

IMPORTANT: Pre-drill before fixing screws.

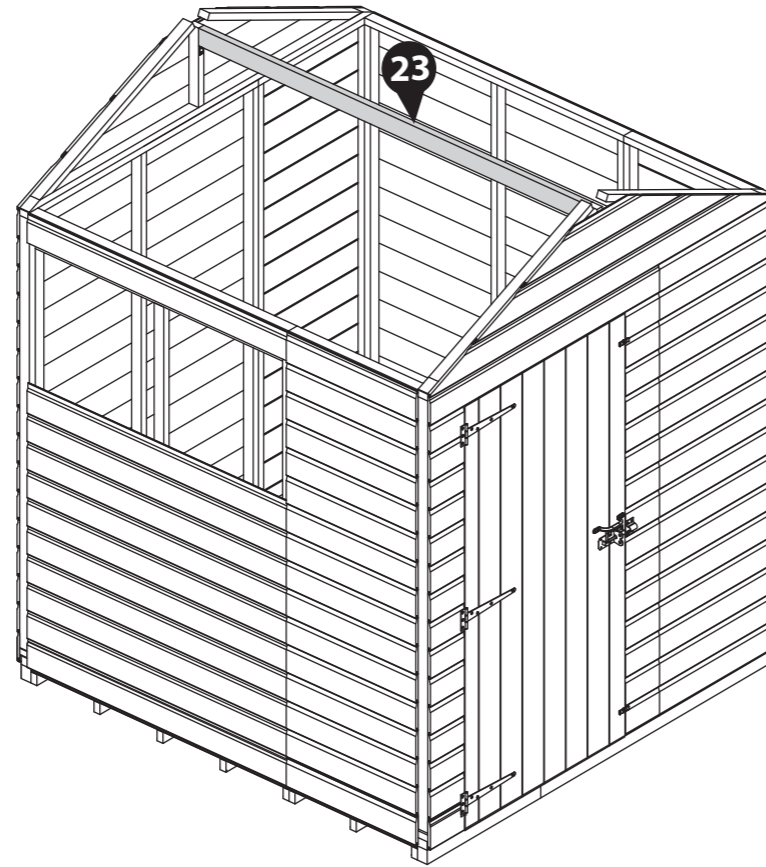

IMPORTANT: Pre-drill before fixing screws.

Step 19	Parts Needed		
Building	No. 7	No. 8	50mm screw
All sizes	QTY 2	QTY 4	QTY 4

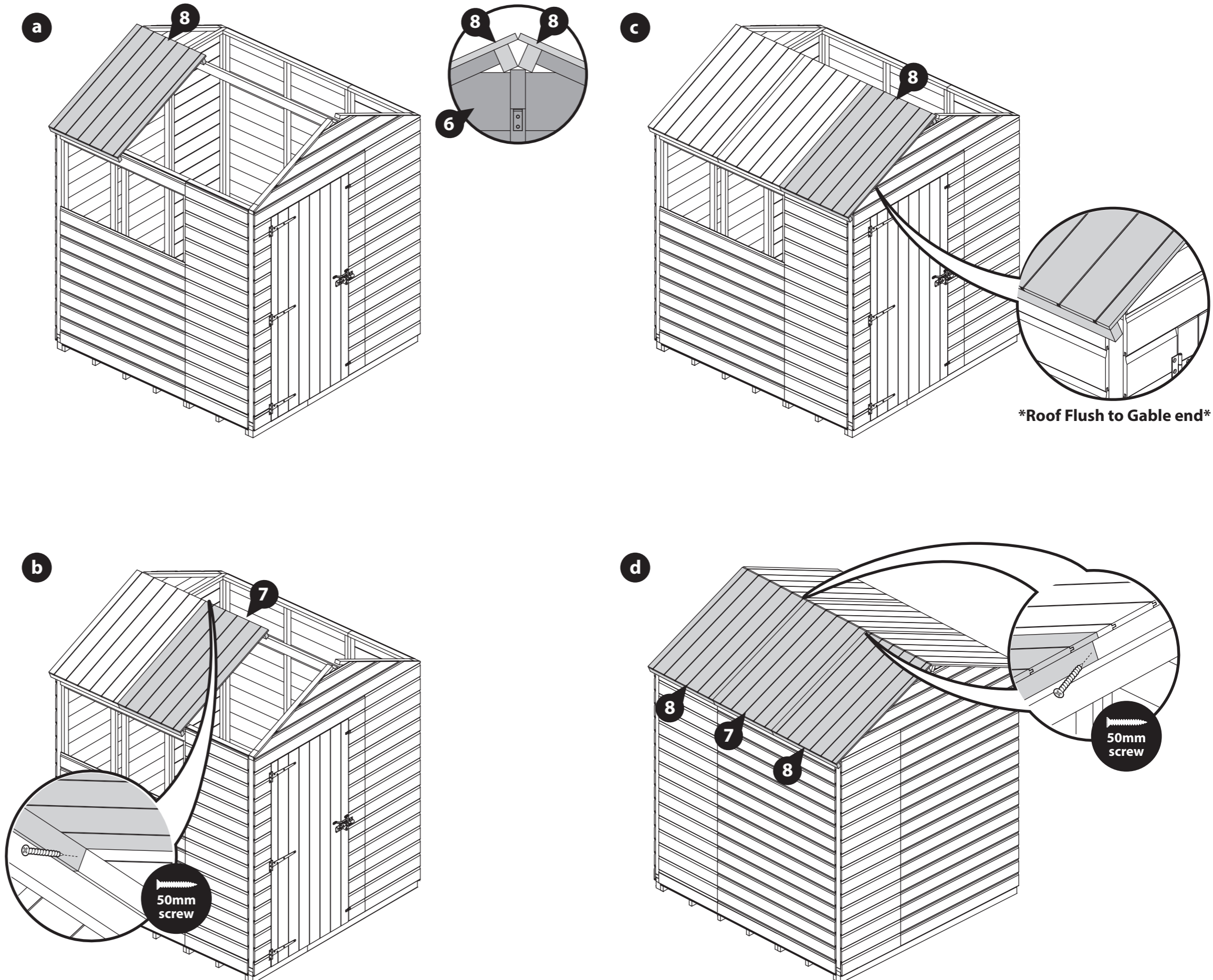

a At one end of the building, position a Large 2ft Roof Panel (**No. 8**) onto the Gable Top (**No. 6**), ensuring the Roof Panel framing sits firmly within the notches on the Gable Top and on top of the Ridge Bar (**No. 22**).

****Make sure that you have the Roof Panels the correct way round with the recess at the top of the apex, as shown in the diagram.****

b Place one Small 2ft Roof Panel (**No. 7**) next to the Large 2ft Roof Panel (**No. 8**), ensuring the framing is flush, level and that the Panels sit firmly on the Ridge Bar.

Secure the Panels together by screwing through the top framing at an angle using 1x50mm screw.

c Position another Large 2ft Roof Panel (**No. 8**) next to the Small 2ft Roof Panel (**No. 7**), ensuring the Roof Panel framing sits firmly within the notches on the Gable Top and on top of the Ridge Bar (**No. 22**).

Secure the Panels together by screwing through the top framing at an angle using 1x50mm screw.

Once three Roofs are in place on one side, **ensure they are pushed flush to the end the greenhouse will be built on**, as shown. This means the Roof will overhang past the Gable at one end.

d Repeat this method to locate the remaining Roof Panels onto the other side of the building, ensuring they align with the previously fitted Panels. Secure the Panels together by screwing through the underside of the framing into the adjacent Panel.

Please note: the 'Greenhouse door on the end, shed door on the inside' configuration has been shown for illustrative purposes and may differ from your chosen configuration. However the process of fitting the Roof Panels is the same.



Step 20 **Parts Needed**

Building	60mm screw
All sizes	QTY 6

Once the Roof Panels are in place and positioned centrally to the building, they can be fixed in place.

Ensure to check that your Roof Panels are aligned. The framing should be sat in the Gable Tops, align with the opposite roof and be flush at the ends.

Internally, screw up at an angle through the Ridge Bar (**No. 23**) into the Roof Panels (**No. 7 & 8**) framing above using 1x70mm screws per Roof Panel.

Ensure to stagger the screws to avoid collision.

It is essential that the Ridge Bar (**No. 23**) and Roof Panels (**No. 7 & 8**) framing pull together when secured. You may require another person pushing the Ridge Bar (**No. 23**) up from below to achieve this.

Please note: the 'Greenhouse door on the end, shed door on the inside' configuration has been shown for illustrative purposes and may differ from your chosen configuration. However the process of fixing the Ridge Bar is the same.



IMPORTANT: Pre-drill before fixing screws.

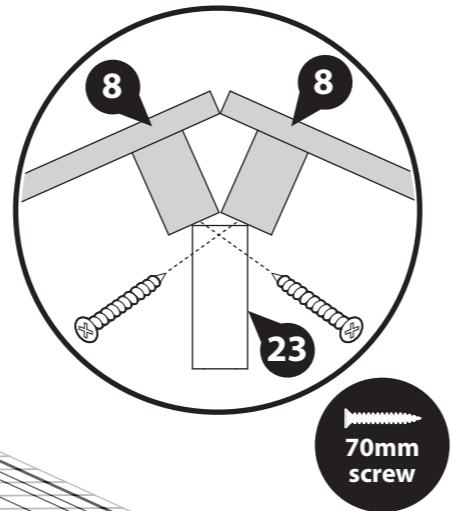

Step 21 **Parts Needed**

Building	No. 26	30mm screw
All sizes	QTY 2	QTY 10

On either side of the Ridge bar, position a Shed Truss Frame (**No. 26**), underneath the Roof Panels (**No. 7**) central to the building.

Tip: To get the Truss central, use a tape measure to find the middle of the walls, mark with a pencil or tape and align the truss to the mark.

Ensure the Shed Truss Frame (**No. 26**) sits flush to the underside of the Roof Panel cladding and flush to the top framing, as shown.

Fix the Shed Truss Frame (**No. 26**) in place using 5x30mm screws per frame, screwing down through the Roof Panels (**No. 7**) into the Shed Truss Frame (**No. 26**) from the outside of the building.

It is essential that the Shed Truss Frame (**No. 26**) and Roof Panels (**No. 7**) pull together when secured. You may require another person pushing the Shed Truss Frame (**No. 26**) up from below to achieve this.

Please note: the 'Greenhouse door on the end, shed door on the inside' configuration has been shown for illustrative purposes and may differ from your chosen configuration. However the process of fitting the Truss Frame is the same.



IMPORTANT: Pre-drill before fixing screws.

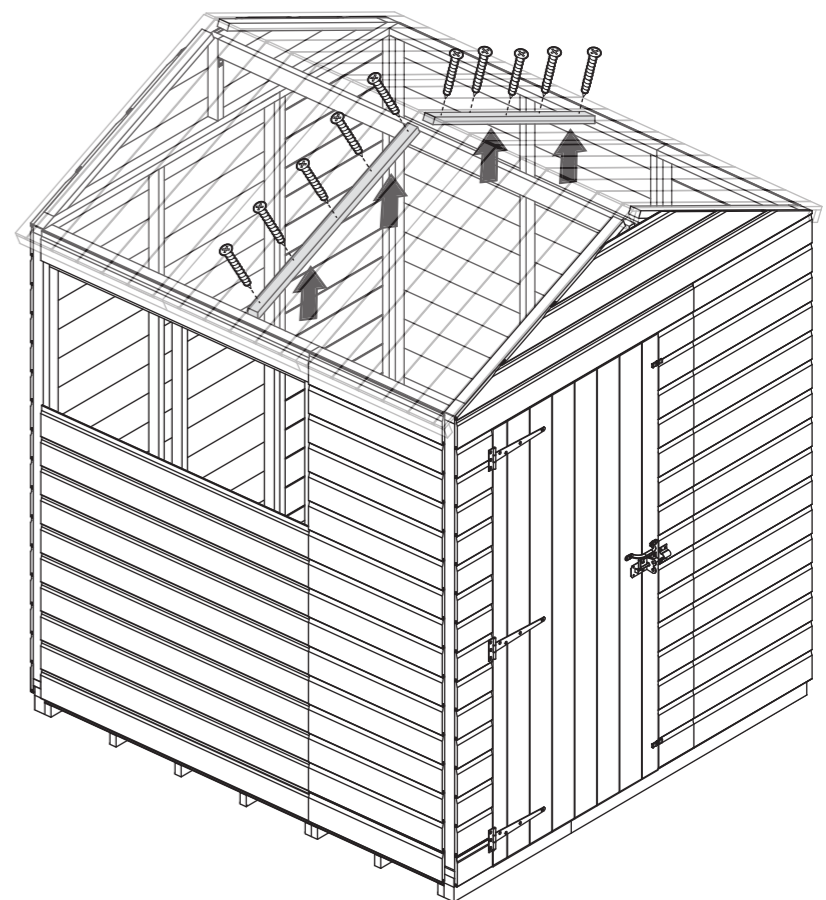
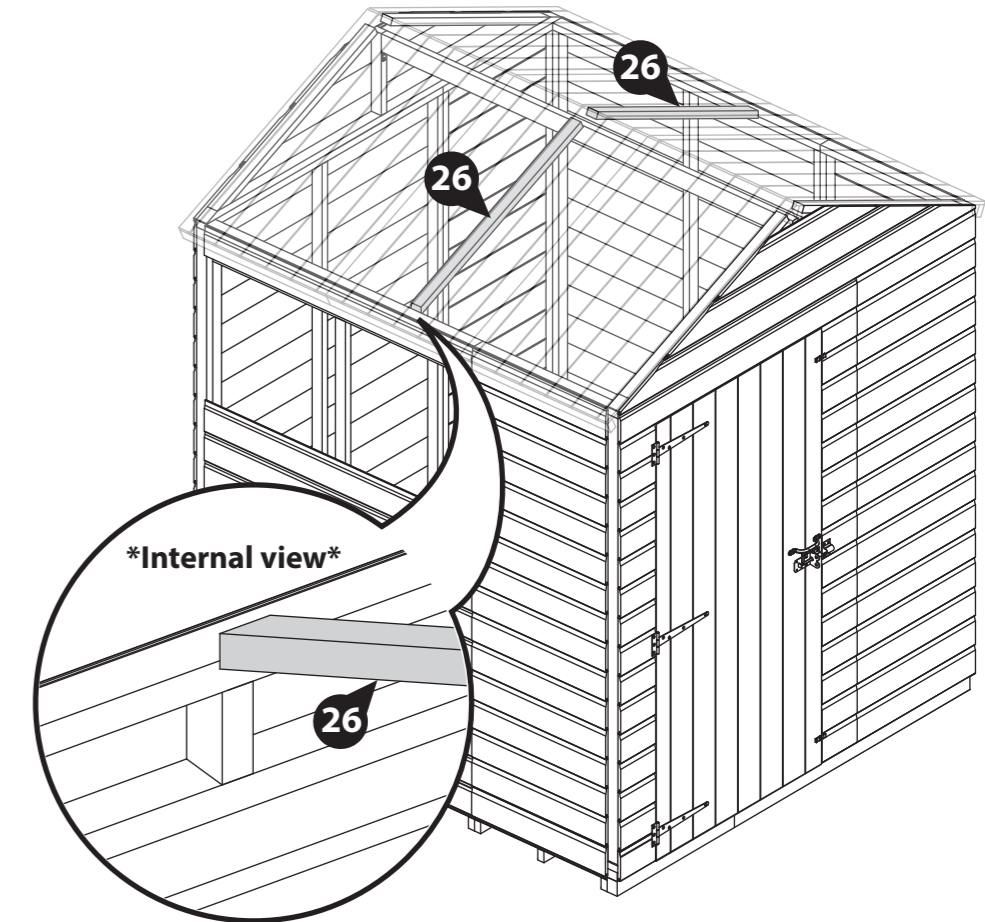

Step 22	Parts Needed	
Building	No. 28	40mm screw
All sizes	QTY 2	QTY 4

Please note: You have been supplied with two Truss Support Blocks (No. 28) however you may only need to use one.

Depending on how you have arranged your 4ft Panels, you may need to use the Truss Support Blocks (No. 28) to help secure your truss.

Check if there is a piece of upright framing below the previously positioned Shed Truss Frame (No. 26). If not, then you will need to use the Truss Support Blocks (No. 28).

To locate a Truss Support Block (No. 28), position the block flush to the internal Panel cladding and the underside of the top framing. Ensure it is in line with the Shed Truss Frame (No. 26), as shown.

Secure the block in place using 2x40mm screws, screwing through the outside cladding into the block inside.

Repeat on the opposite side of the building if necessary.

Please note: the 'Greenhouse door on the end, shed door on the inside' configuration has been shown for illustrative purposes and may differ from your chosen configuration. However the process of fitting the Truss Support Block is the same.

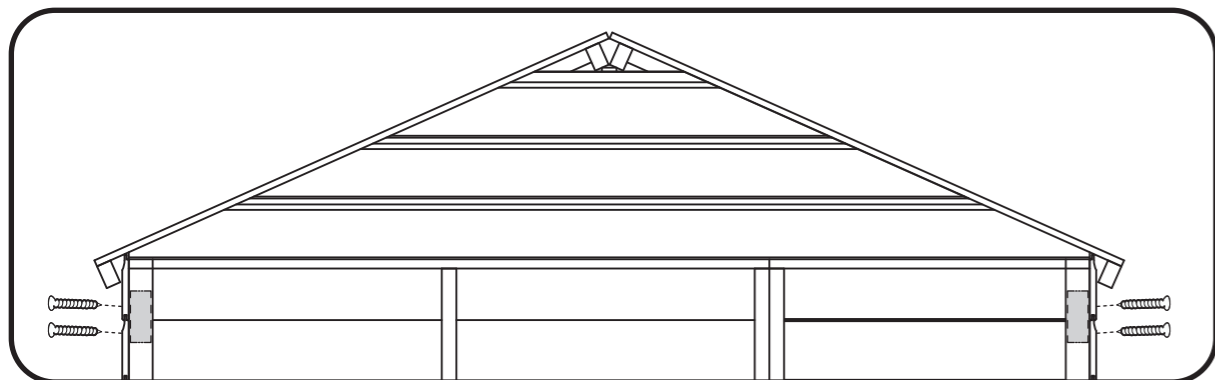
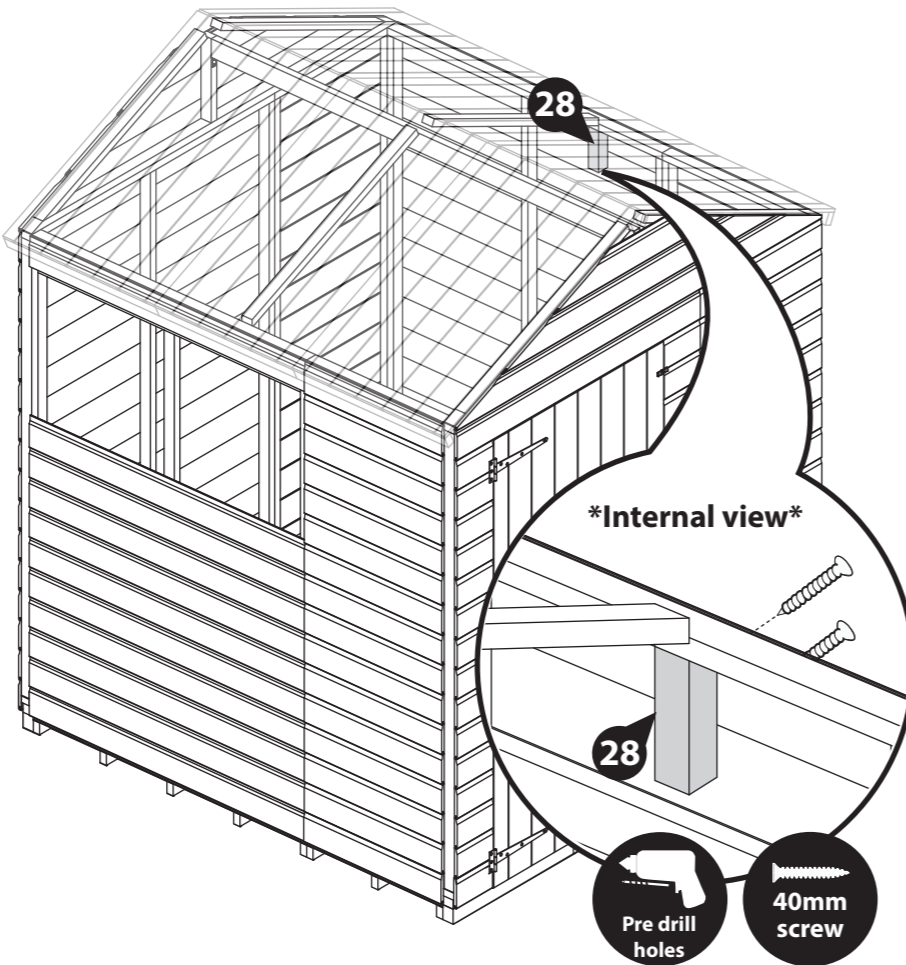
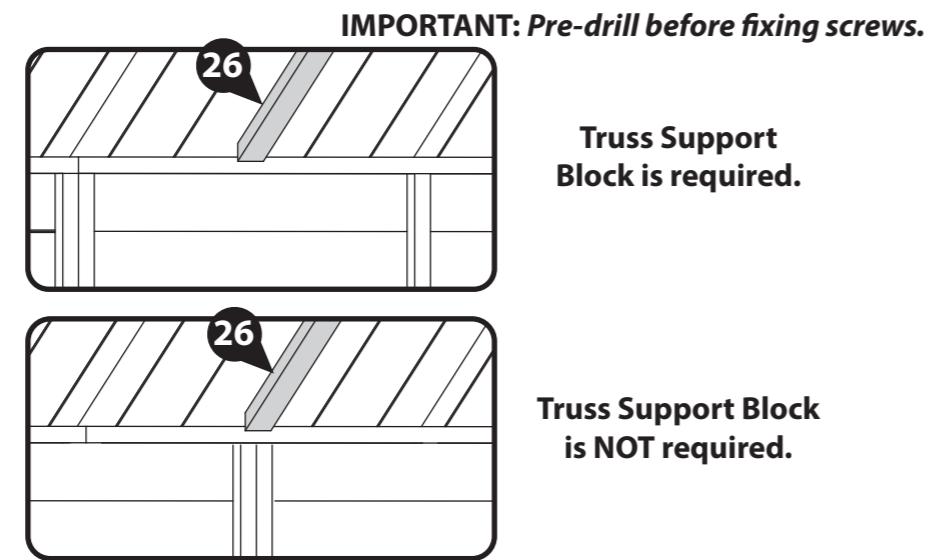

Step 23	Parts Needed	
Building	No. 29	50mm screw
All sizes	QTY 2	QTY 4

Place the Truss Block (No. 29) up to the Shed Truss Frame (No. 26) so the angled cut edge is facing upwards, flush to the Shed Truss Frame (No. 26)

Ensure the block is also flush to the framing (Support Block or panel upright) behind.

Fix in place using 2x50mm screws through the block into the framing behind. Ensure to stagger screws to avoid collision.

Repeat on the opposite side of the building.

Please note: the 'Greenhouse door on the end, shed door on the inside' configuration has been shown for illustrative purposes and may differ from your chosen configuration. However the process of fitting the Truss Block is the same.

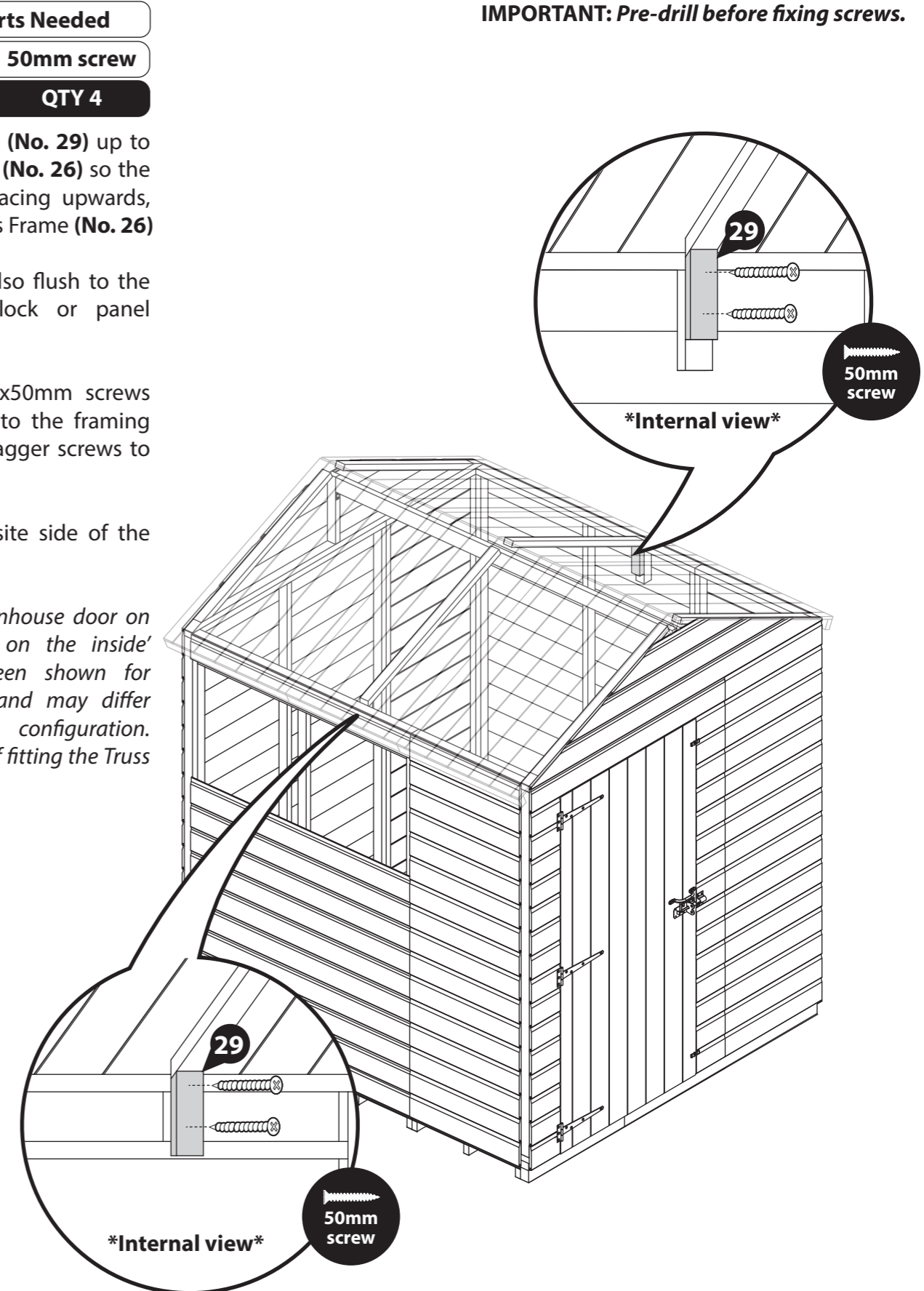

Step 24 Parts Needed

Building	No. 30	40mm screw
All sizes	QTY 1	QTY 4

Place the Truss Support (No. 30) underneath the two Shed Truss Frames (No. 26) ensuring it sits flush to both.

The Truss Support (No. 30) should sit horizontal - parallel to the floor.

Once in position fix the Truss Support (No. 30) in place with 2x40mm screws at each end of the truss.

Please note: the 'Greenhouse door on the end, shed door on the inside' configuration has been shown for illustrative purposes and may differ from your chosen configuration. However the process of fitting the Truss Support is the same.

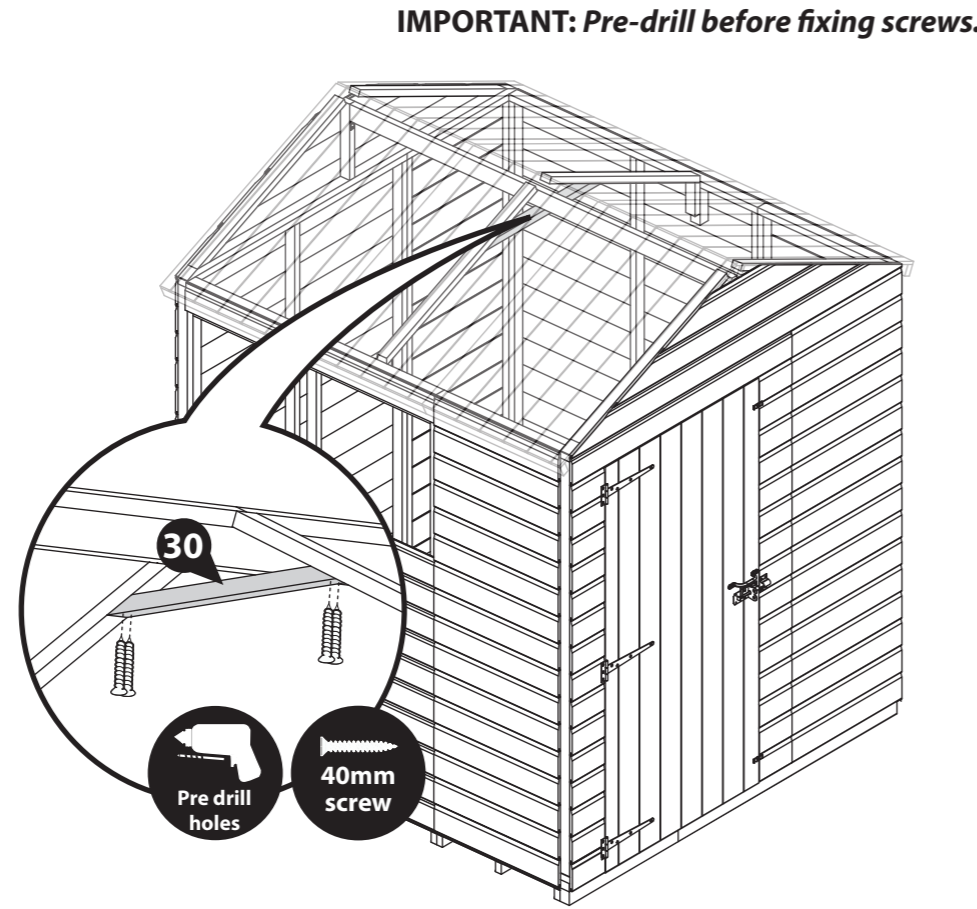

Step 25 Parts Needed

Building	40mm screw
All sizes	QTY 26

Make sure the building is square by measuring from corner to corner and comparing the measurements. If the measurements are equal, the building is square, if not, adjustments may be required.

Once square, secure the Roofs (No. 7 & 8) in place using 40mm screws by screwing down through the cladding into the Panel framing below.

Ensure there is no more than 300mm between each screw and that each screw is countersunk to avoid interference when felting.

Please note: the 'Greenhouse door on the end, shed door on the inside' configuration has been shown for illustrative purposes and may differ from your chosen configuration. However the process of fixing the Roof is the same.

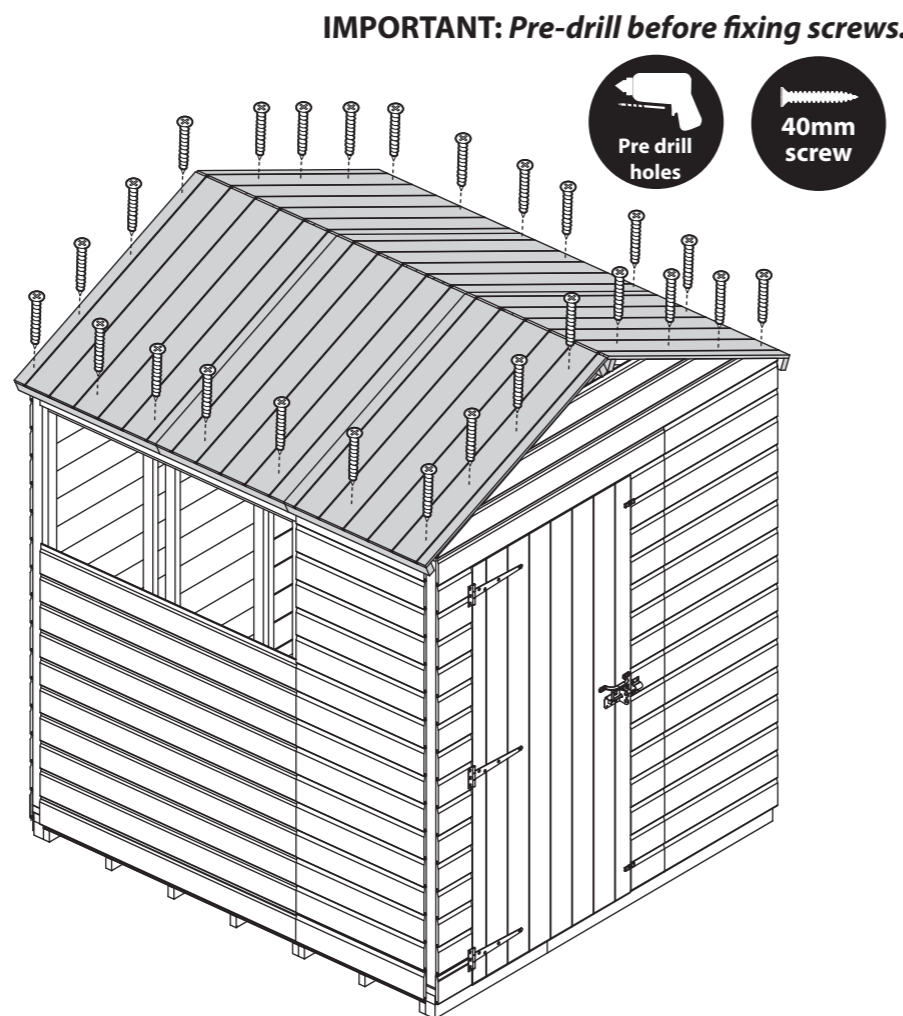

Step 26 Parts Needed

Building	50mm screw
All sizes	QTY 20

Once the Roof is fixed, secure the Panels to the floor using 50mm screws, screwing down through the Panel framing into the Floor bearers below.

Please note: If you have purchased a Panel Brace kit when fixing near an angled brace, you may need to screw through the Panel framing at an angle to ensure they are in line with the floor bearers.

Please note: the 'Greenhouse door on the end, shed door on the inside' configuration has been shown for illustrative purposes and may differ from your chosen configuration. However the process of fixing the Panels is the same.



b

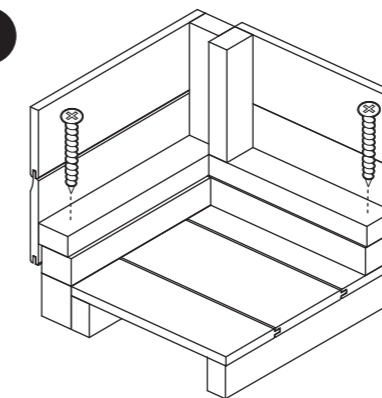

Standard Panels

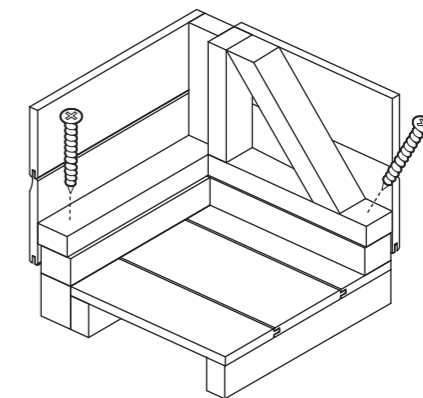

Panel brace kit ONLY



Step 27

Parts Needed

Building	No. 21	30mm screw
All sizes	QTY 8	QTY 20

On the bottom of each assembled Panel, slot a Panel Cover (**No. 21**) into the exposed groove in the cladding, as shown. Ensure the end of the Panel Cover is flush with the Panel cladding.

**Please note, some of the Panel Covers will need cutting to size.*

Secure each Panel Cover in place using 3x30mm screws for the 4ft panels and 2x30mm screws for the 2ft Panels, screwing through the cladding into the framing behind.

Please note: the 'Greenhouse door on the end, shed door on the inside' has been shown for illustrative purposes and may differ from your chosen configuration. However the process of fitting the Panel Covers is the same for all.

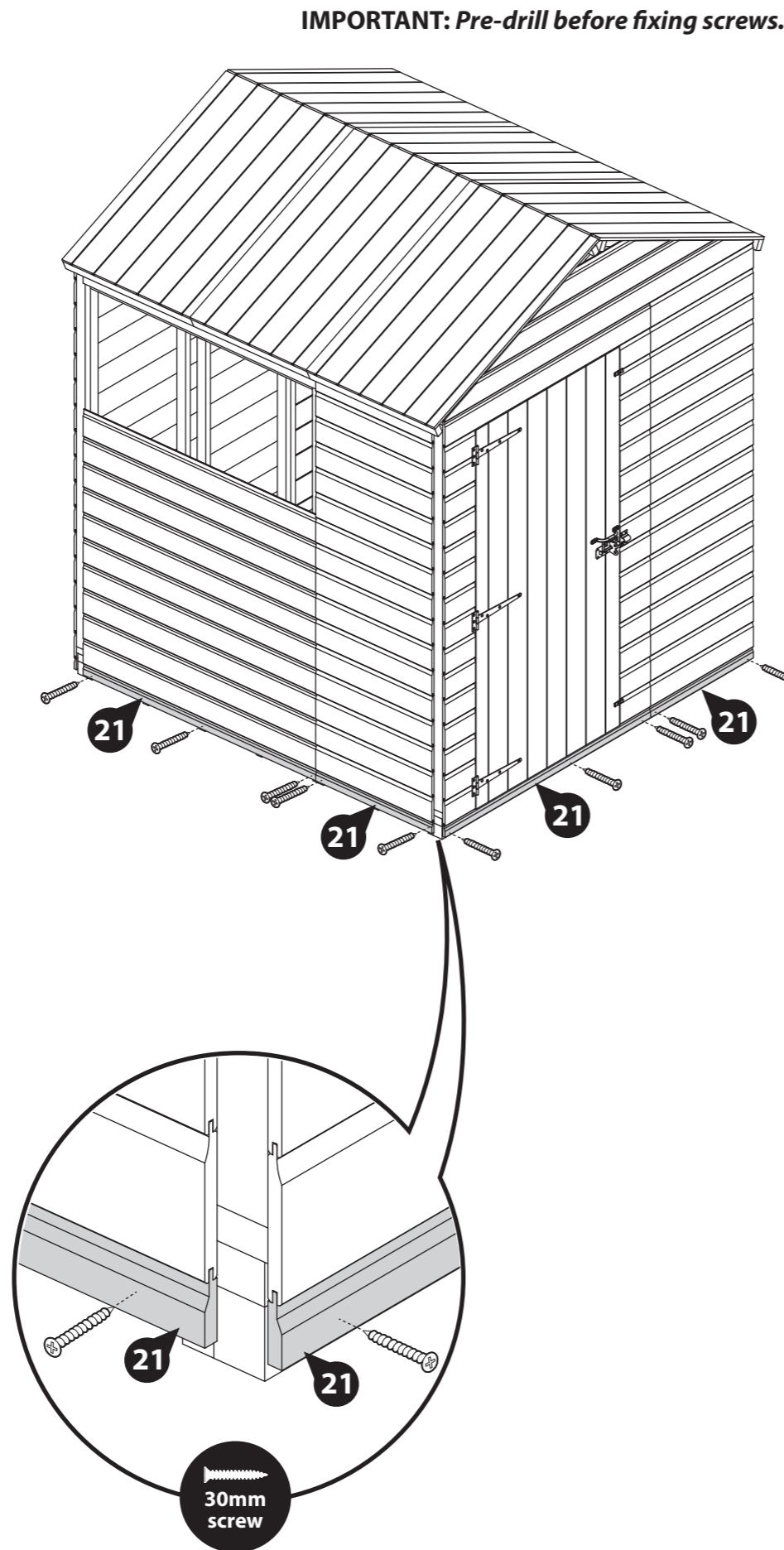

Step 28

Parts Needed

Building	No. 31	No. 32	No. 47	No. 48	30mm screw
All sizes	QTY 1	QTY 5	QTY 1	QTY 2	QTY 21

a Inside the 4ft Window Panel (**No. 4a**) opening, locate one Window Strip (**No. 32**) to either side of the outer window framing exposed in the window gap, as shown. Secure in place using 3x30mm screws per Strip.

b Place the Plastic Window Cill (**No. 47**) onto the 4ft Window Panel (**No. 4a**) opening. Ensure the cill sits on top of the cladding and flush to the central upright. Secure in place using 3x30mm screws, screwing through the cill into the framing behind.

c Position the Styrene sheets (**No. 48**) on top of the Plastic Window Cill (**No. 47**), ensuring they are equally spaced in the window openings.

For added weather protection, use a sealant application gun to apply a neat line of Clear Silicone around the outside edges of the styrene.

***Silicone sealant not provided.*

d Position the remaining three Window Strips (**No. 32**) on top of the cill on either side of the Styrene and the centre. Place the Top Window Strip (**No. 31**) above the previously placed strips, along the top of the window opening.

Secure in place using 3x30mm screws per strip. Ensure to screw through the strips into the framing behind, not the styrene.

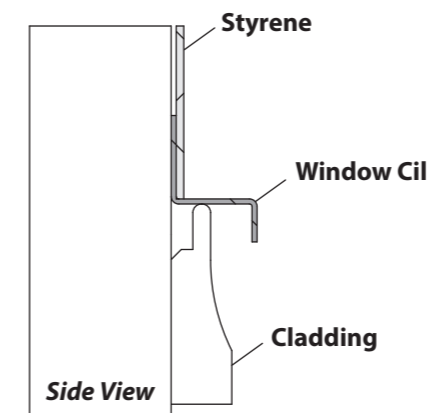

IMPORTANT: Pre-drill before fixing screws.

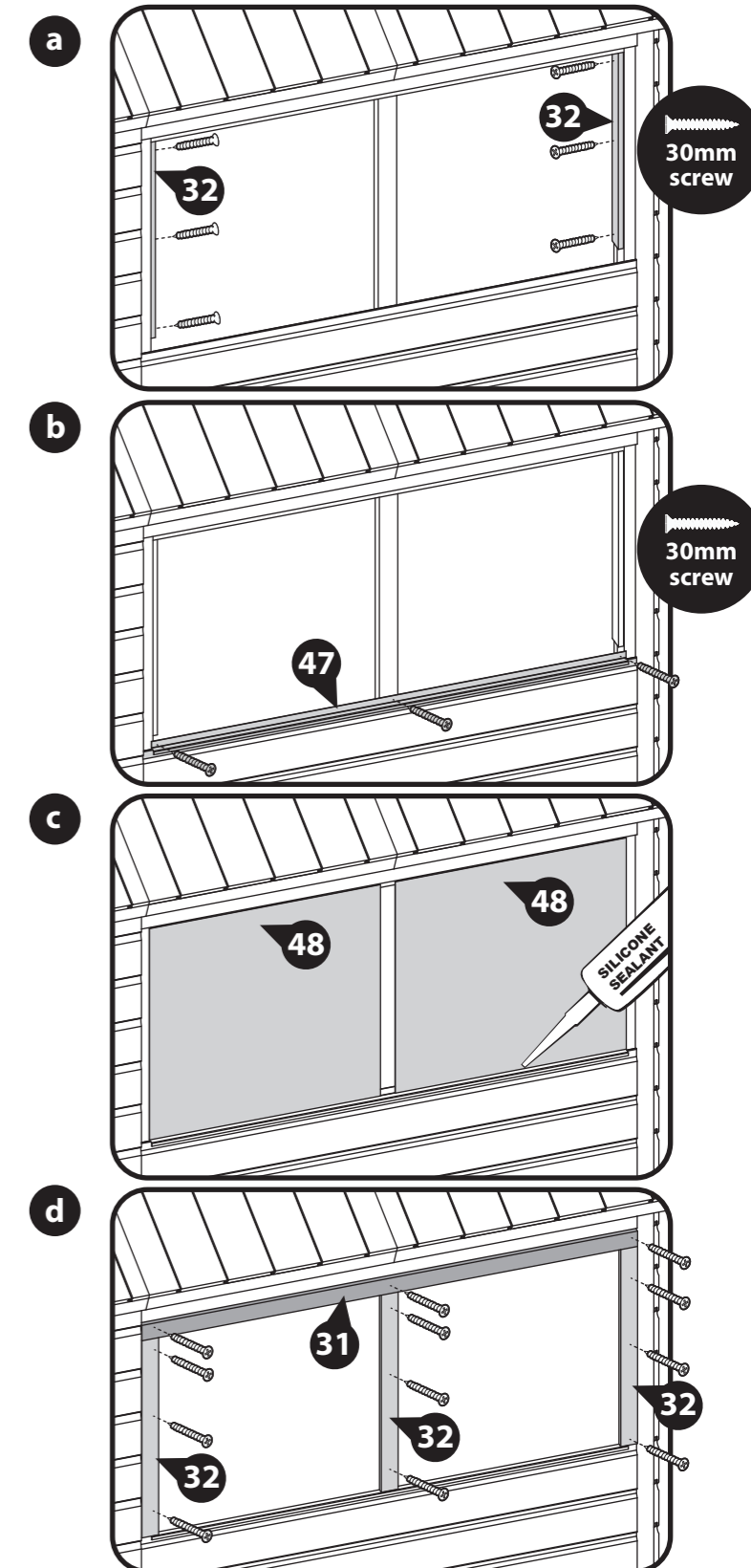

IMPORTANT: Pre-drill before fixing screws.

Step 29

Parts Needed

Building	No. 49	Felt Tacks
All sizes	QTY 1	QTY 100

- a** Cut the Felt (**No. 49**) into three sheets measuring: **2000mm (L) x 1000mm (W)**.

Lay the sheets onto the roof in the order shown in the diagram, ensuring there is a 50mm overhang around the sides and that each sheet overlaps by 100mm.

- b** Secure the Felt in place by hammering felt tacks into the overlapping layers, the front, back and sides of the building at 100mm intervals, as shown.

Ensure to fold the corners of the felt over each other to create a neat finish, as shown.

Please note: the 'Greenhouse door on the end, shed door on the inside' has been shown for illustrative purposes and may differ from your chosen configuration. However the process of fitting the Felt is the same for all.

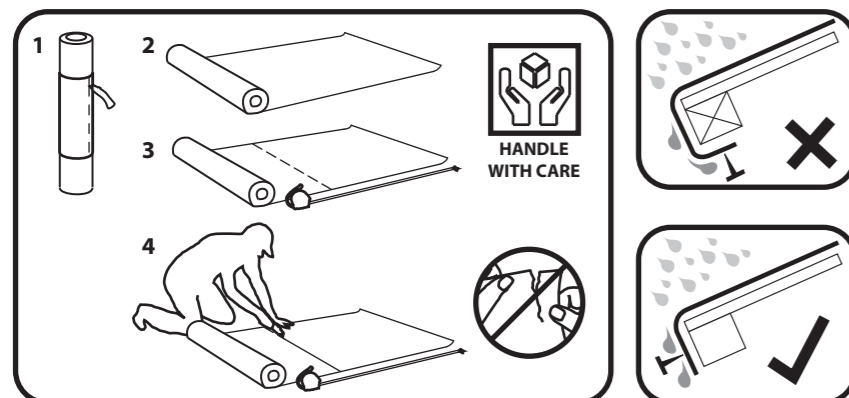
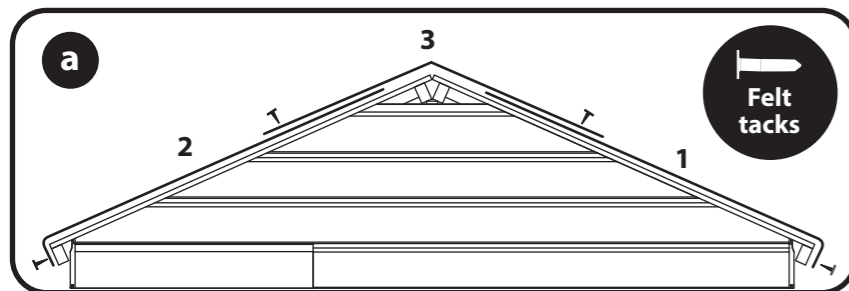
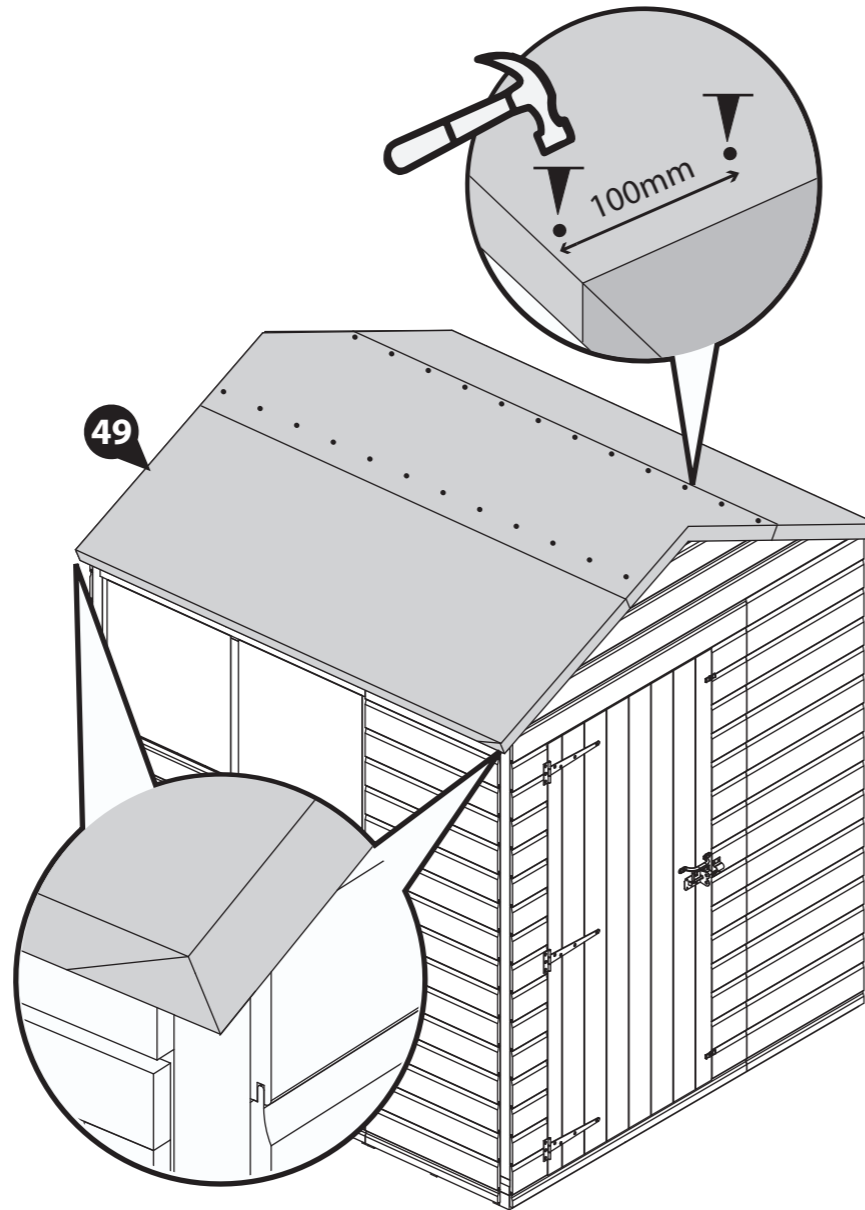

Step 30

Parts Needed

Building	No. 9a	No. 11	No. 52	30mm black screw
All sizes	QTY 1	QTY 1	QTY 3	QTY 27

- a** Lay the 2ft Single Door Panel (**No. 9a**) face up on a flat and level surface.

To ensure the panel is the correct way up, check that the internal lips on either side of the upright framing are visible.

- b** Place the Door (**No. 11**) within the Door Panel opening so it is sat on the internal lipped edges.

Ensure there is equal spacing on all sides and that the cut outs on the Door are lined up with the cut out in the door frame.

Locate the Greenhouse T-Hinges (**No. 52**) onto the Door and Door Panel, ensuring the Hinges line up with the Door framing.

Secure in place using 9x30mm black screws per hinge.

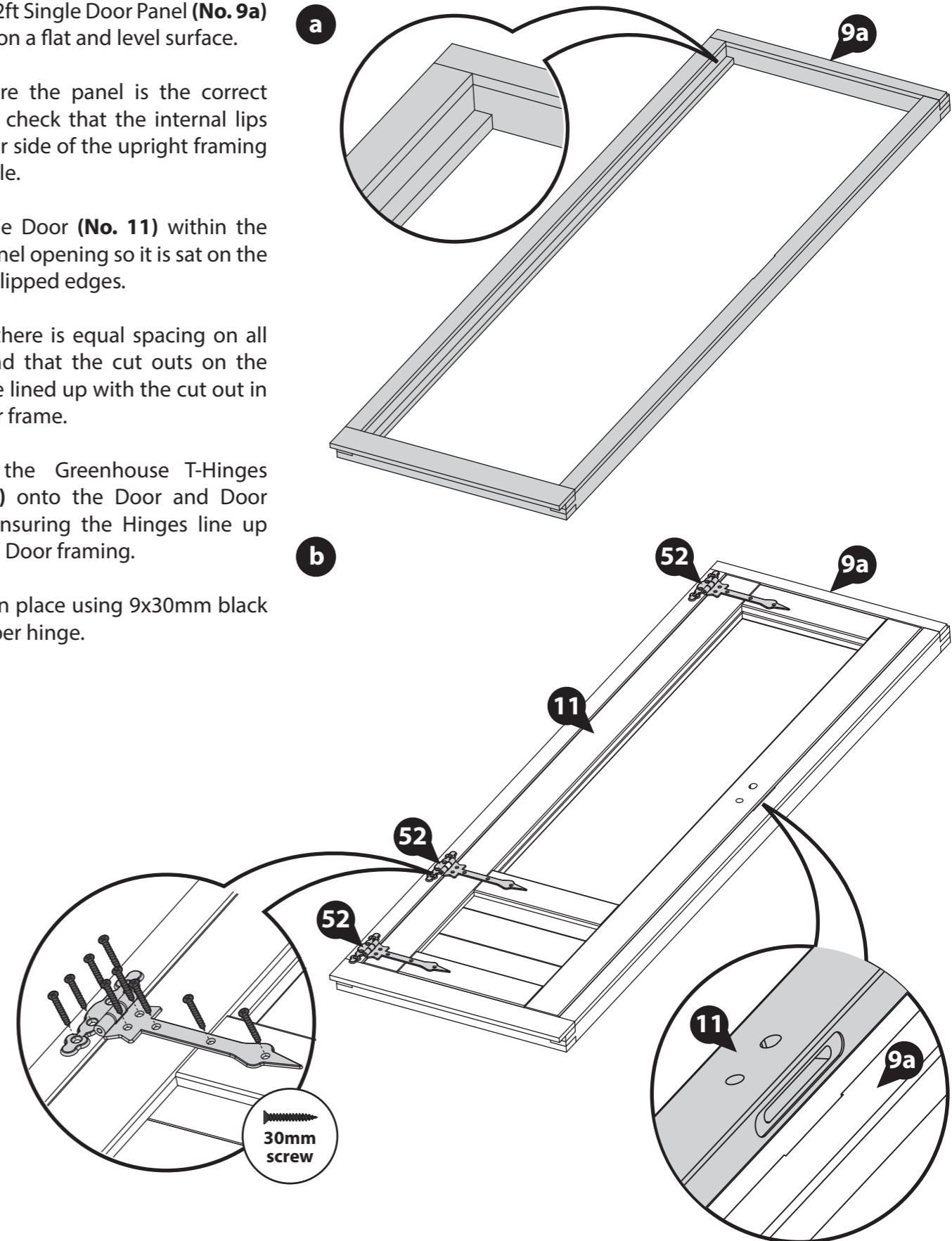

Step 31

Parts Needed			
Building	No. 53	No. 54	30mm screw
All sizes	QTY 1	QTY 1	QTY 4

Open the Door and locate the Lock (No. 53) into the recess of the Door (No. 11). Fix in place using 2x30mm screws.

Locate the Key-Plate (No. 54) onto the recess on the inside of the Door Panel (No. 9a). Fix in place using 2x30mm screws.

Do NOT shut the door fully until the Handle Set has been fitted in step 32.

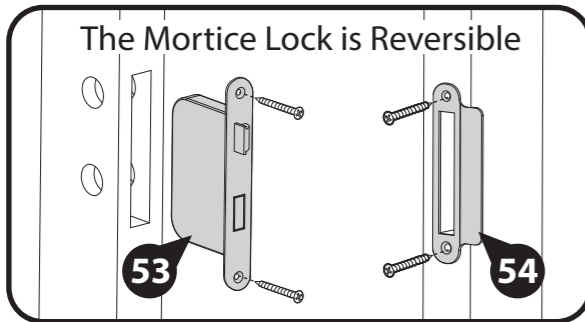

IMPORTANT: Pre-drill before fixing screws.

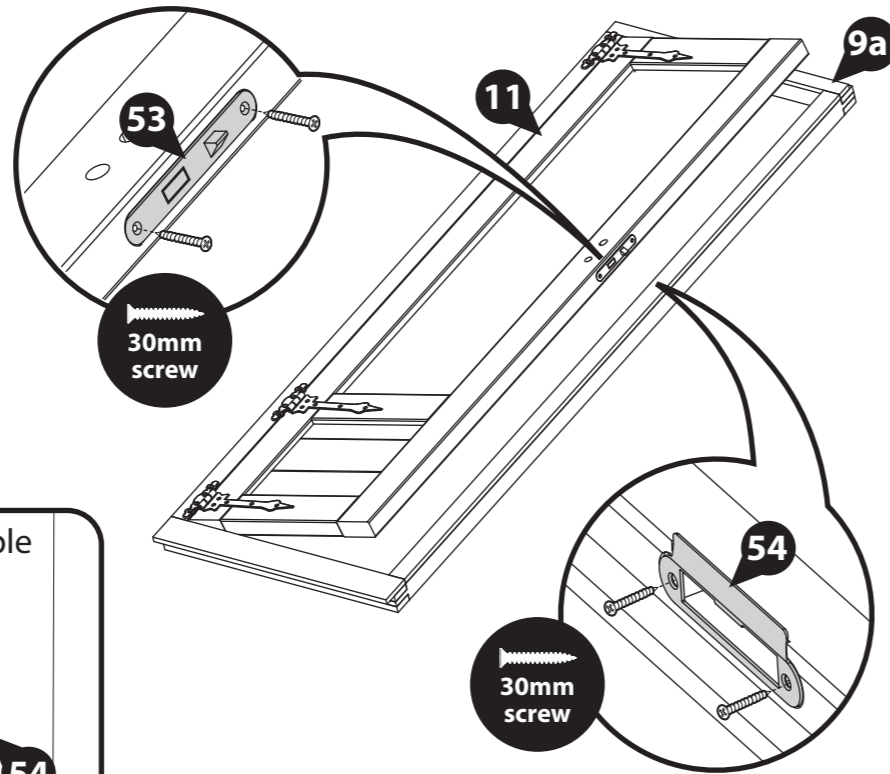

Step 33

Please refer to your '6ft Base frame' instruction manual to assemble your 6ft Apex Combi base frame.

It is essential to complete the steps explained in this additional guide before continuing the construction of your building.

Please note: the 14x6 'Greenhouse door on the end, shed door on the inside' has been shown for illustrative purposes and may differ from your chosen configuration. However the process of fitting the base frame is the same for all.

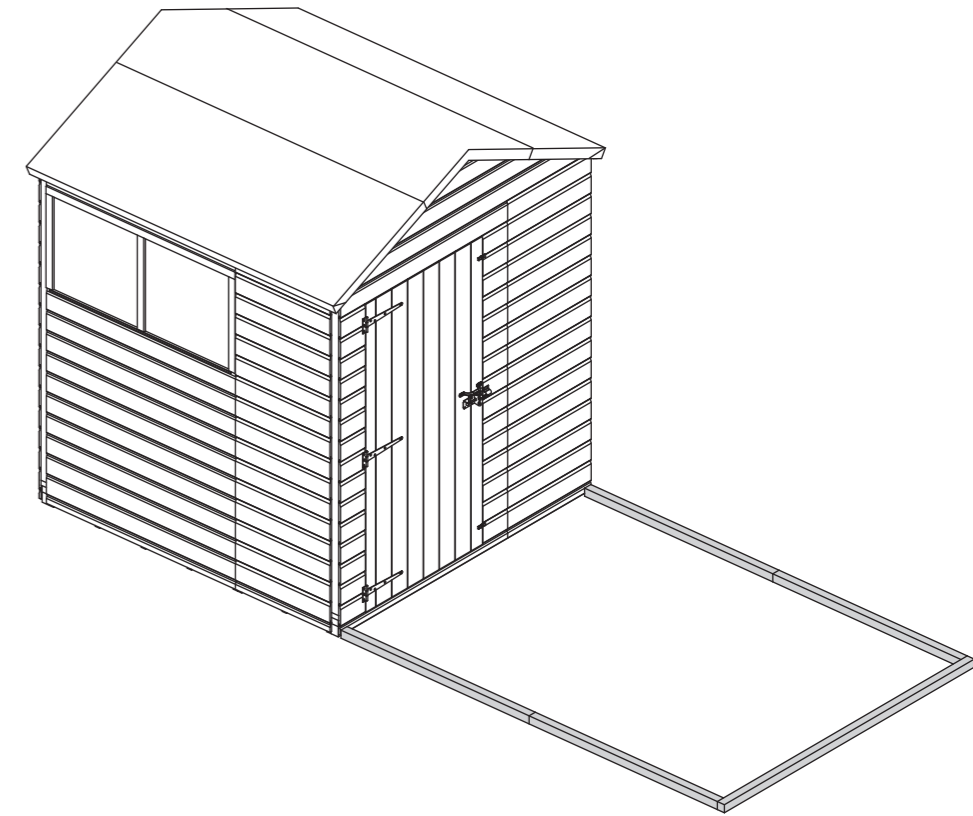

Step 32

Parts Needed		
Building	No. 55	30mm black screw
All sizes	QTY 1	QTY 8

From the Handle Set (No. 55) position the Metal Bar through the Door and lock and connect one handle onto either side, as shown.

Fix each Handle in place using 4x30mm black screws.

Before closing the door, ensure the door mechanism works by checking that the lock (No. 53) moves with the Handle set.

Then, check the door can open and close freely.

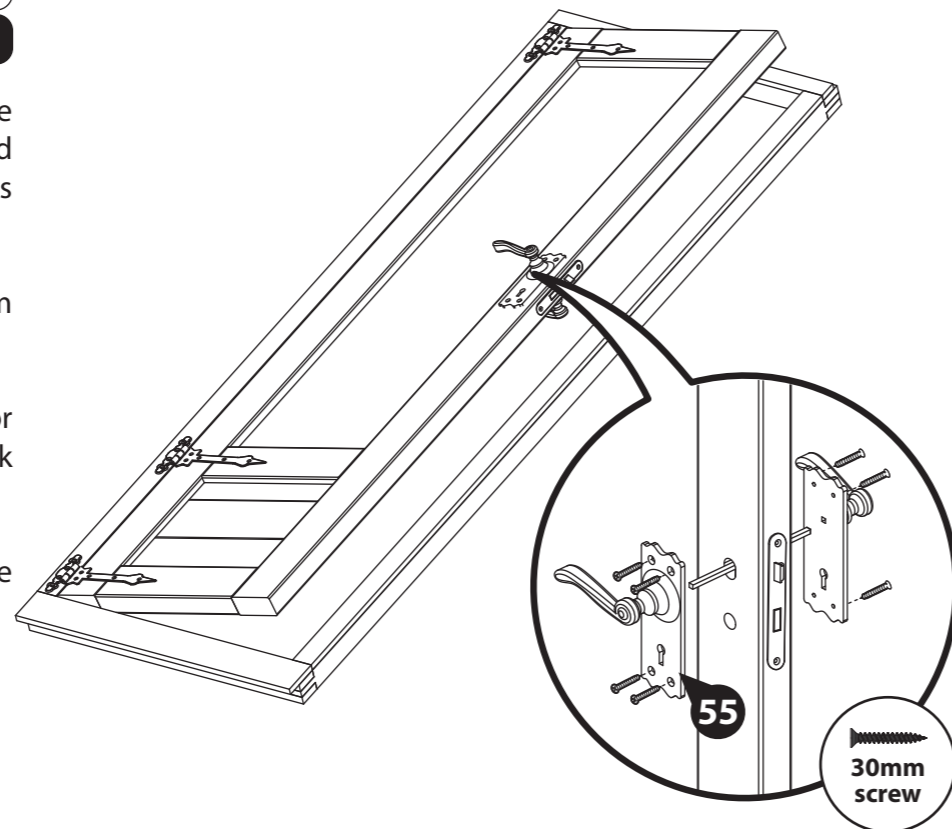

IMPORTANT: Pre-drill before fixing screws.

Step 34

With your base constructed, decide how you want your interchangeable panels to sit.

If you have not yet assembled your base framing, please refer to the 'Base frame construction' manual provided with your building.

It is advised to lay your panels around the base frame in the desired positions, an example is shown below.

Please note: the 14x6 'Greenhouse door on the end, shed door on the inside' has been shown for illustrative purposes and may differ from your chosen configuration. However the process of laying out the Panels is the same for all.

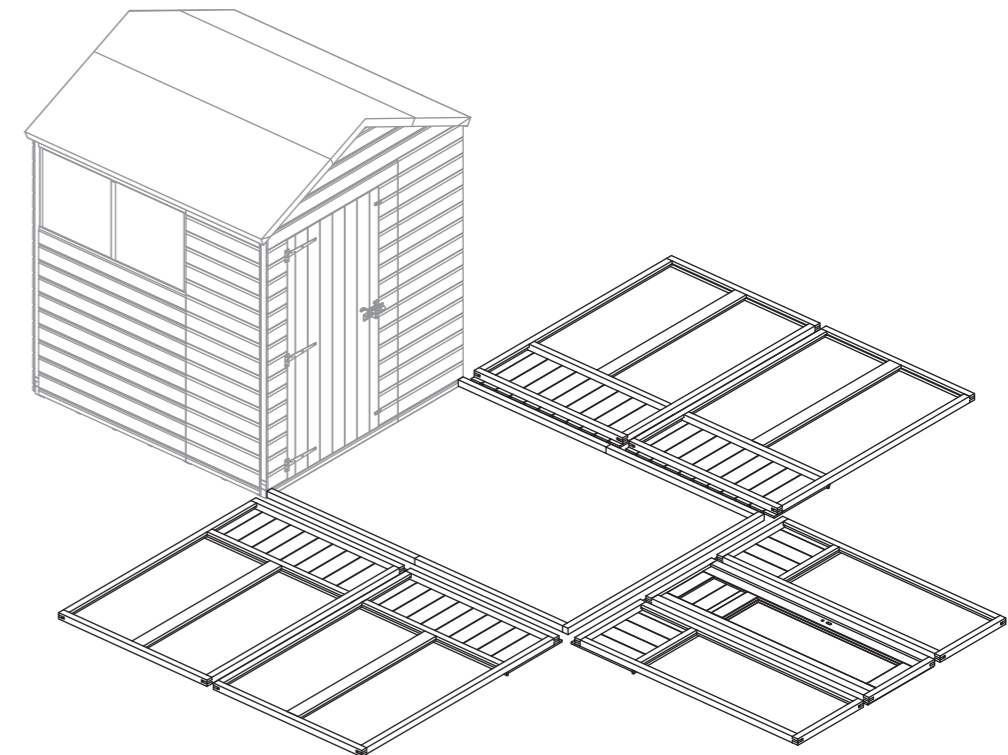

IMPORTANT: Pre-drill before fixing screws.

Step 35		Parts Needed	
Building	No. 9 (a or b)	No. 10	60mm screw
10x6	-	QTY 2	QTY 6
12x6	QTY 2	-	QTY 6
14x6	-	QTY 2	QTY 6

On top of the base frame on either side, flush to the shed panels, position two:

10x6 & 14x6: 4ft Glazing Panels (**No. 10**)

12x6: 2ft Panels (**No. 9a or 9b**)

Secure the Panels to the shed Panels at the corners using 3x60mm screws per corner, as shown.

Ensure to position the Panels so the framing on one side is flush to the shed and so there is equal spacing between the overhanging cladding and the base frame on all sides.

Do NOT secure the building to the base frame until the roof has been fitted.

Please note: the 'Greenhouse door on the end, shed door on the inside' has been shown for illustrative purposes and may differ from your chosen configuration. However the process of fitting the panels is the same for all.



a

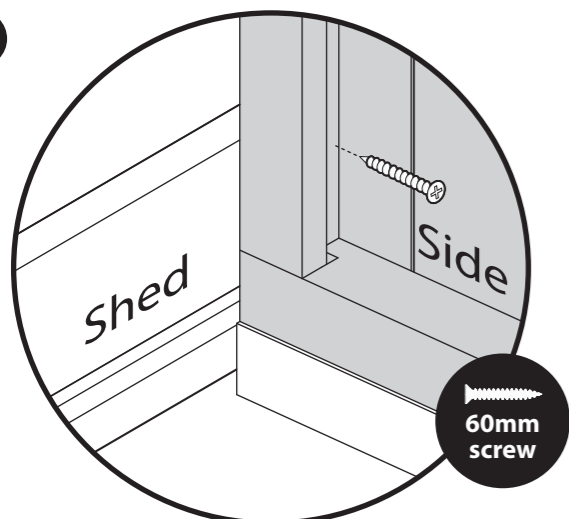

10x6

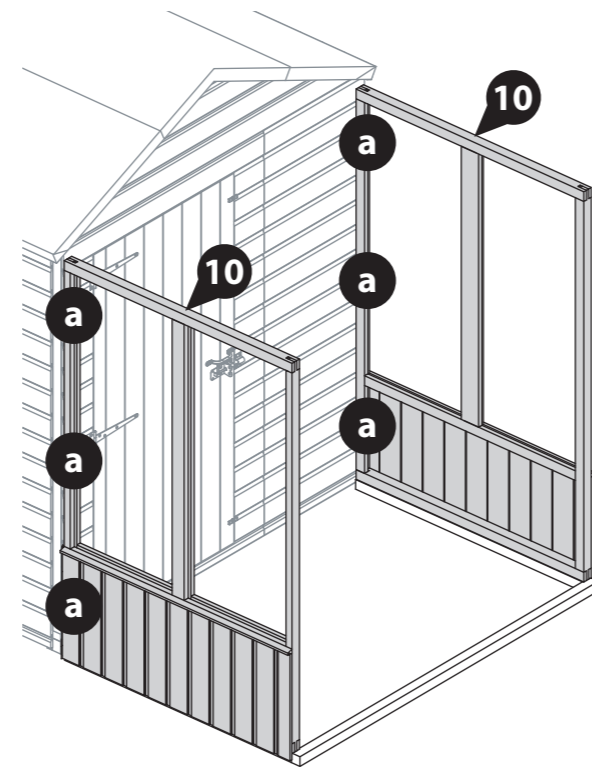

14x6

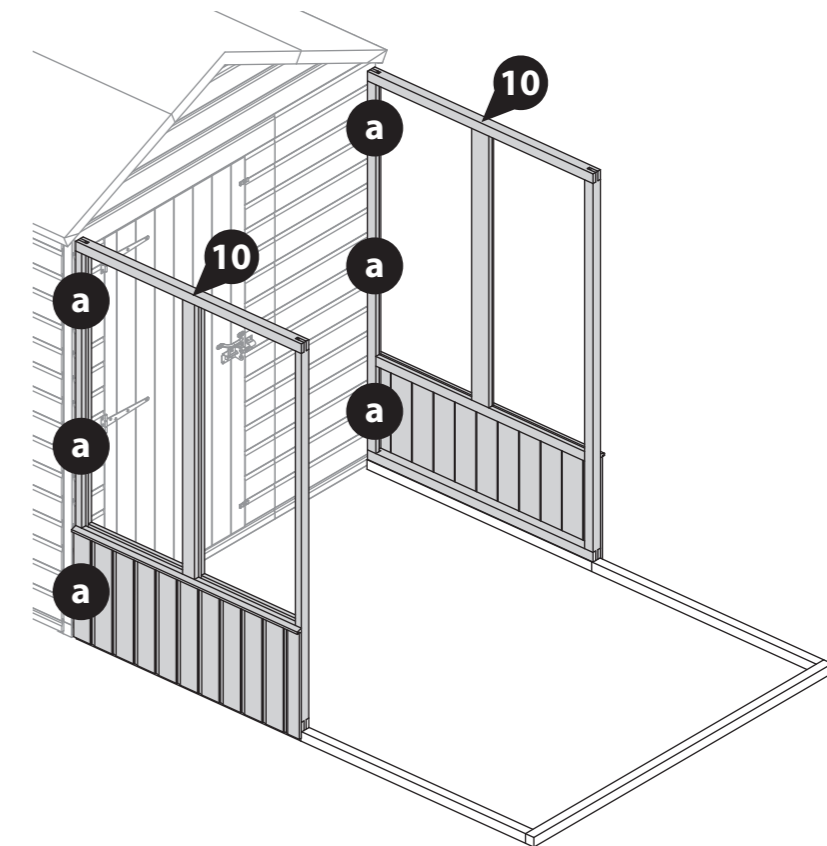

12x6

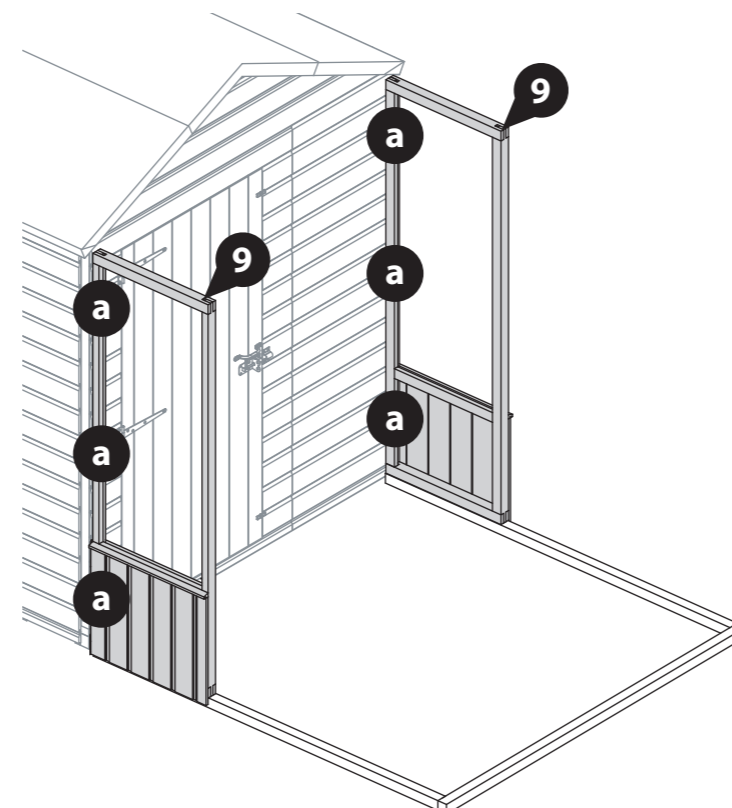

IMPORTANT: Pre-drill before fixing screws.

Step 36

Parts Needed

Building	No. 10	60mm screw
10x6	-	-
12x6	QTY 2	QTY 6
14x6	QTY 2	QTY 6

If you have purchased a 10x6 building, please skip to the next step (Step 37).

Locate one 4ft Glazing Panel (**No. 10**) next to the previously placed Panels on either side, as shown.

Secure the Panels together using 3x60mm screws per join, as shown.

Make sure to position the Panels so there is equal spacing between the overhanging cladding and the base frame on all sides.

Do NOT secure the building to the base frame until the roof has been fitted.

Please note: the 'Greenhouse door on the end, shed door on the inside' has been shown for illustrative purposes and may differ from your chosen configuration. However the process of fitting the panels is the same for all.

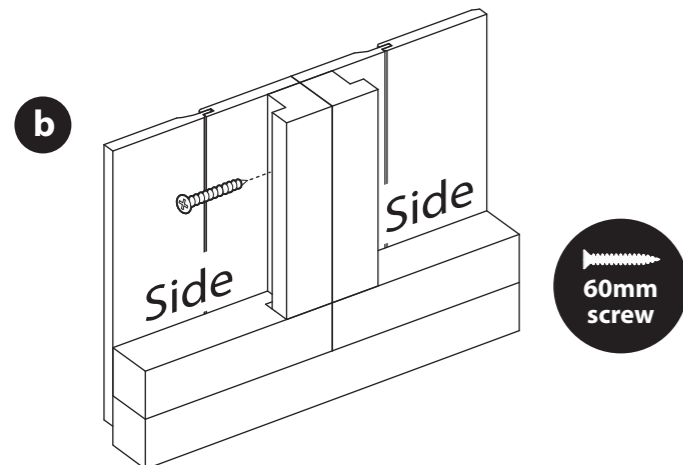

10x6

If you have purchased a 10x6 building, please skip to the next step (Step 37).

14x6

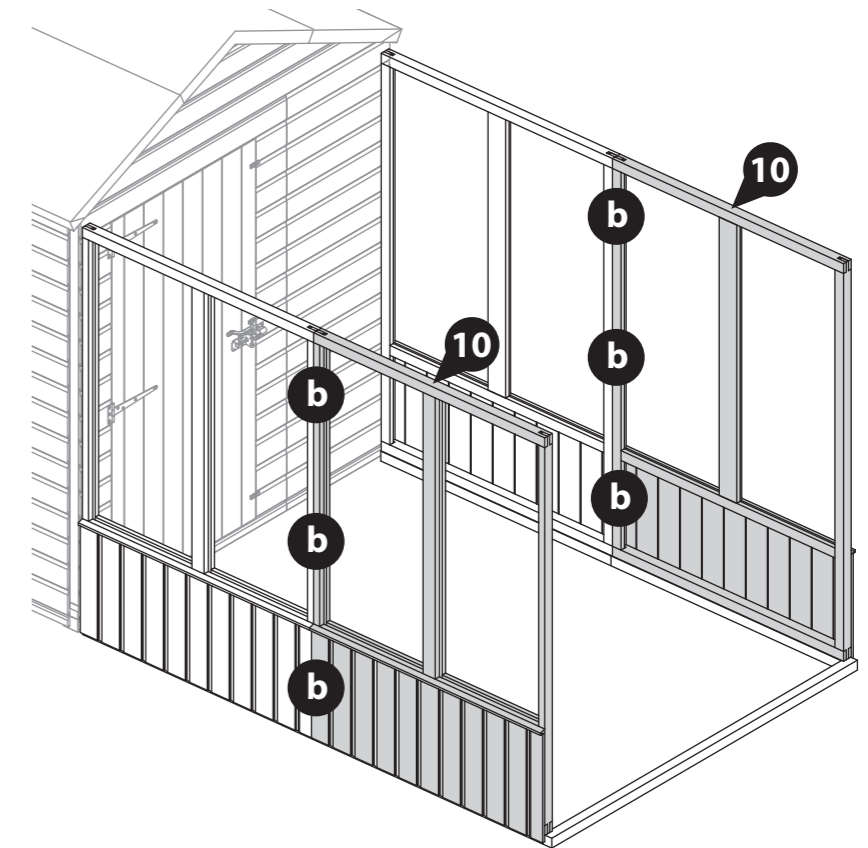

12x6

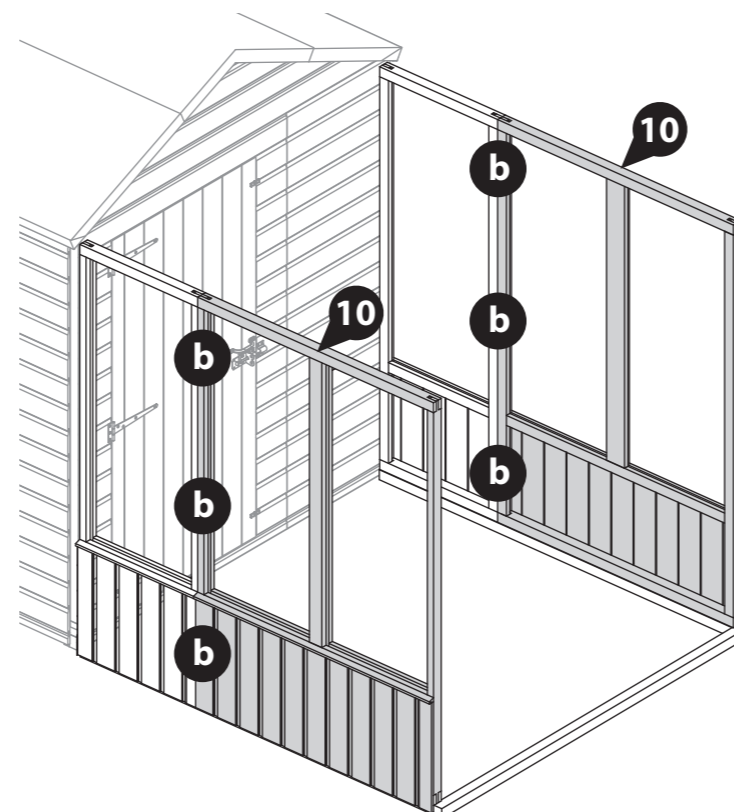

Step 37

Parts Needed

Building	No. 9 (a or b)	60mm screw
All sizes	QTY 3	QTY 12

Locate the remaining 2ft Panels (No. 9a or 9b) on top of the floor at the end, ensuring they sit on the outside of the previously placed panels, as shown.

Fix the Panels together using 3x60mm screws per join, as shown.

Secure the Panels together at the corners using 3x60mm screws per corner.

Make sure to position the Panels so there is equal spacing between the overhanging cladding and the base frame on all sides.

Do NOT secure the building to the base frame until the roof has been fitted.

Please note: the 'Greenhouse door on the end, shed door on the inside' has been shown for illustrative purposes and may differ from your chosen configuration. However the process of fitting the panels is the same for all.

IMPORTANT: Pre-drill before fixing screws.

10x6

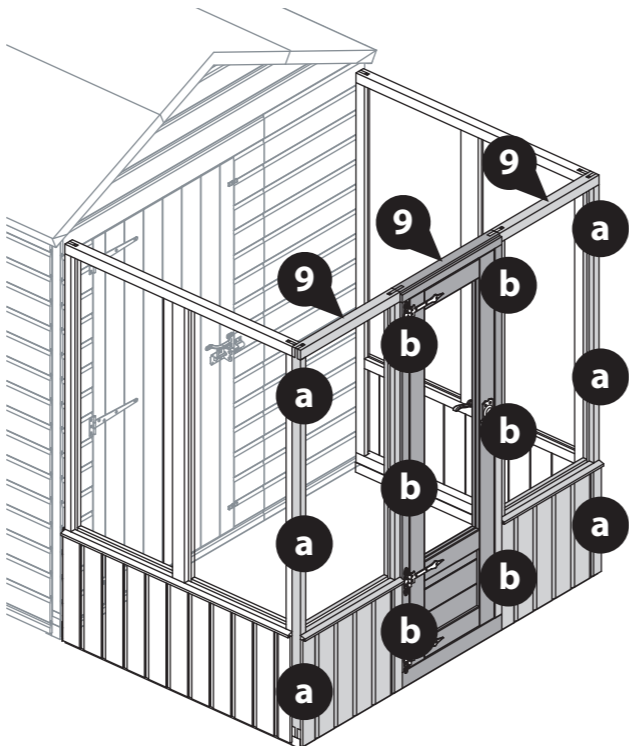

14x6

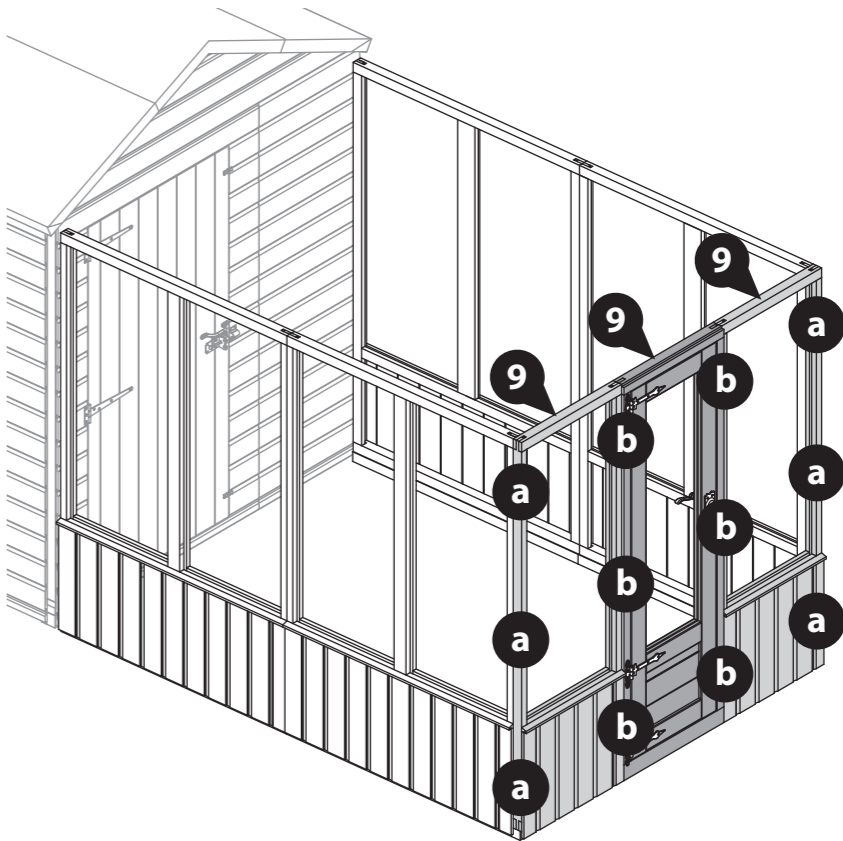

12x6

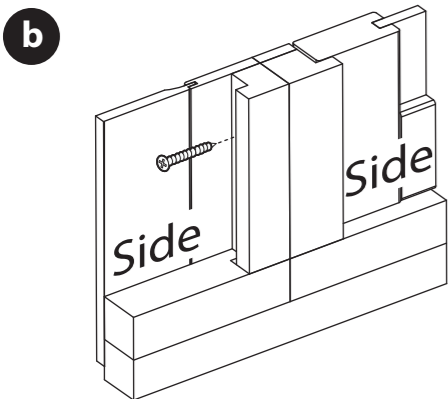
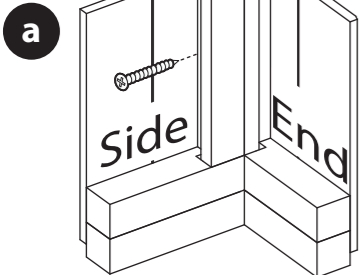
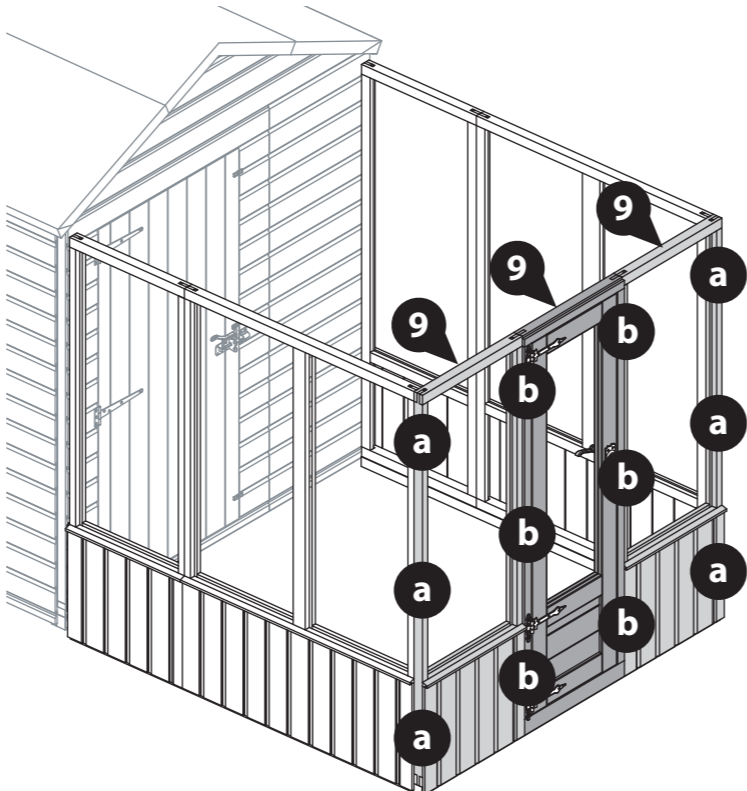

Step 38

Parts Needed

Building	No. 12	60mm screw
All sizes	QTY 1	QTY 4

Locate the Greenhouse Gable Top (No. 12) on top of the end Panels, ensuring that the framing is flush and level.

Secure in place using 4x60mm screws, screwing down through the Gable framing into the Panel below.

Please note: the 14x6 'Greenhouse door on the end, shed door on the inside' has been shown for illustrative purposes and may differ from your chosen configuration. However the process of fitting the Gable Tops is the same for all.

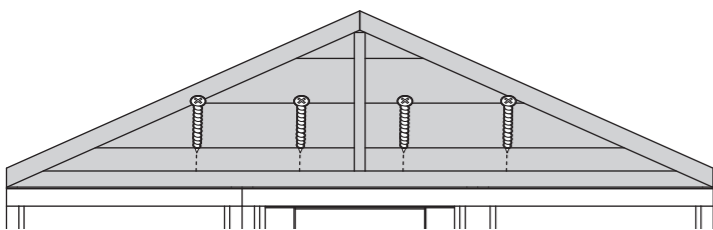

IMPORTANT: Pre-drill before fixing screws.

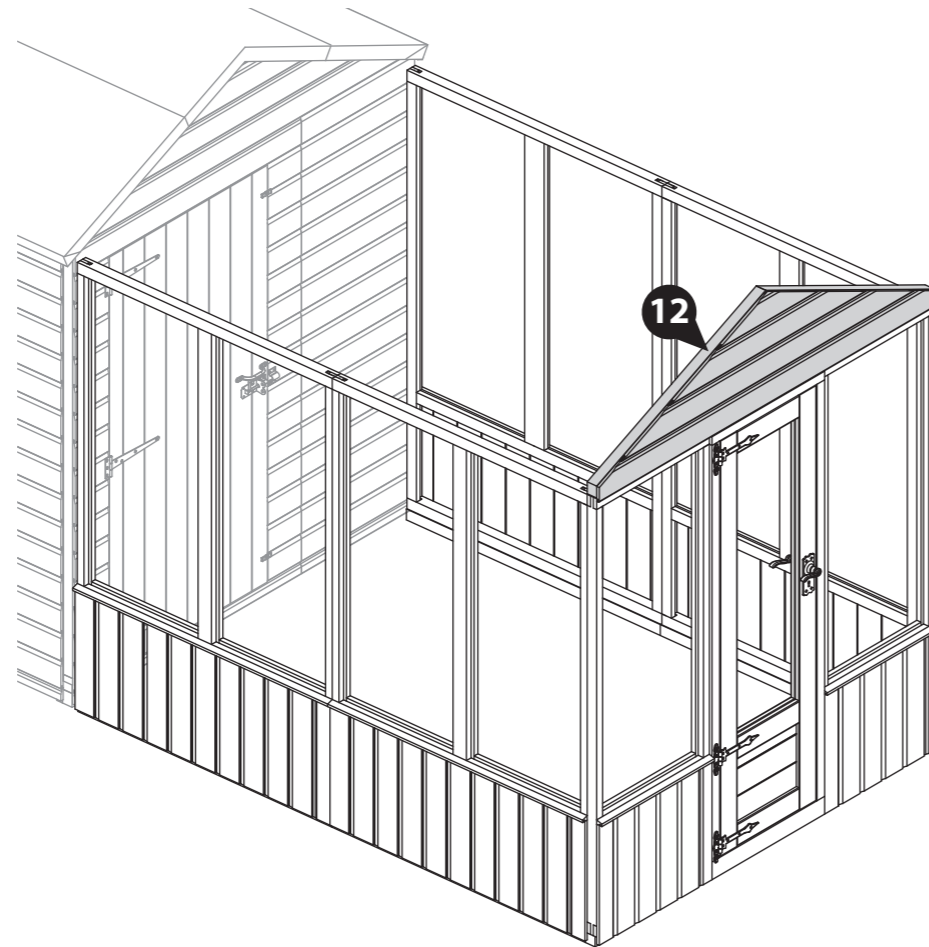

Step 39

Parts Needed

Building	30mm screw
All sizes	QTY 4

Align the assembled Greenhouse Ridge Bar (No. 22 and/or 23) with the central framing of the Gable Top, with the sides are flush and the top is level. Ensure the opposite end is flush to the Shed Gable Top cladding, as shown.

(If you have not yet assembled your Greenhouse Ridge Bar, please refer to Step 17).

Secure the Corner Braces (No. 46) to the central upright of the Gable Top and the Shed Gable Top using 2x20mm screws per brace.

Please note: the 14x6 'Greenhouse door on the end, shed door on the inside' has been shown for illustrative purposes and may differ from your chosen configuration. However the process of fitting the Ridge Bars is the same for all.



IMPORTANT: Pre-drill before fixing screws.

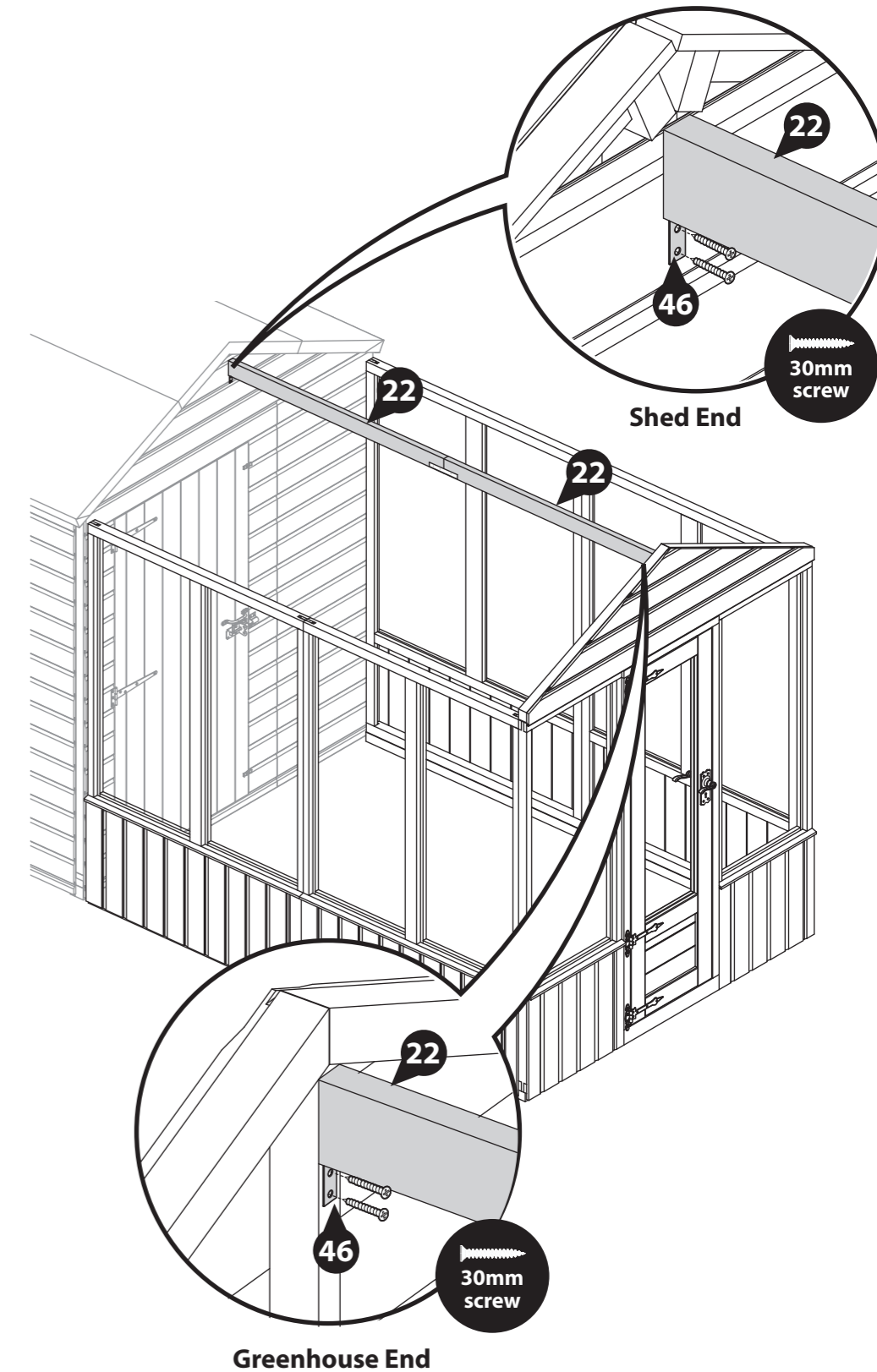

Step 40

Parts Needed

Building	No. 13	No. 15	No. 34	No. 37	No. 50	No. 51	16mm black screw	30mm black screw	30mm screw	50mm screw
All sizes	QTY 1	QTY 1	QTY 1	QTY 1	QTY 2	QTY 1	QTY 4	QTY 16	QTY 2	QTY 2

IMPORTANT: Pre-drill before fixing screws.

- a** Place the 4ft Opening Window Roof (**No. 15**) face up on a flat and level surface.

Position the Window (**No. 13**) and the Window Block (**No. 34**) onto the Roof Panel (**No. 15**) framing, over the open space at the top right of the panel, as shown. The two should be flush and level with the side of the Roof Panel.

Ensuring the Window Block sits just below the top of the Panel and the Window sits on the central framing, secure the Window Block (**No. 34**) in place using 2x50mm screws.

- b** Place the Butt-Hinges (**No. 50**) onto the Window and Window Block. Fix in place using 8x30mm black screws per hinge.

- c** Whilst holding the window shut, flip the Panel over and position the Casement Stay (**No. 51**) centrally inside the Window, so the stay and pins align with the Roof and Window framing, as shown.

***Please ensure to support the window when flipping the panel as the window is not fully secured at this point and WILL open.*

Secure in place using 4x16mm black screws.

- d** With the Panel face down, measure the distance between the roof framing, as shown.

Mark this measurement onto one Cover Trim (**No. 37**) and cut to size.

Position the Cover Trim (**No. 37**) in between the top Roof framing, flush to the top framing. Ensure to cover the join between the Window and Window Block, as shown.

Secure in place using 2x30mm screws, screwing through the trim into the window block behind.

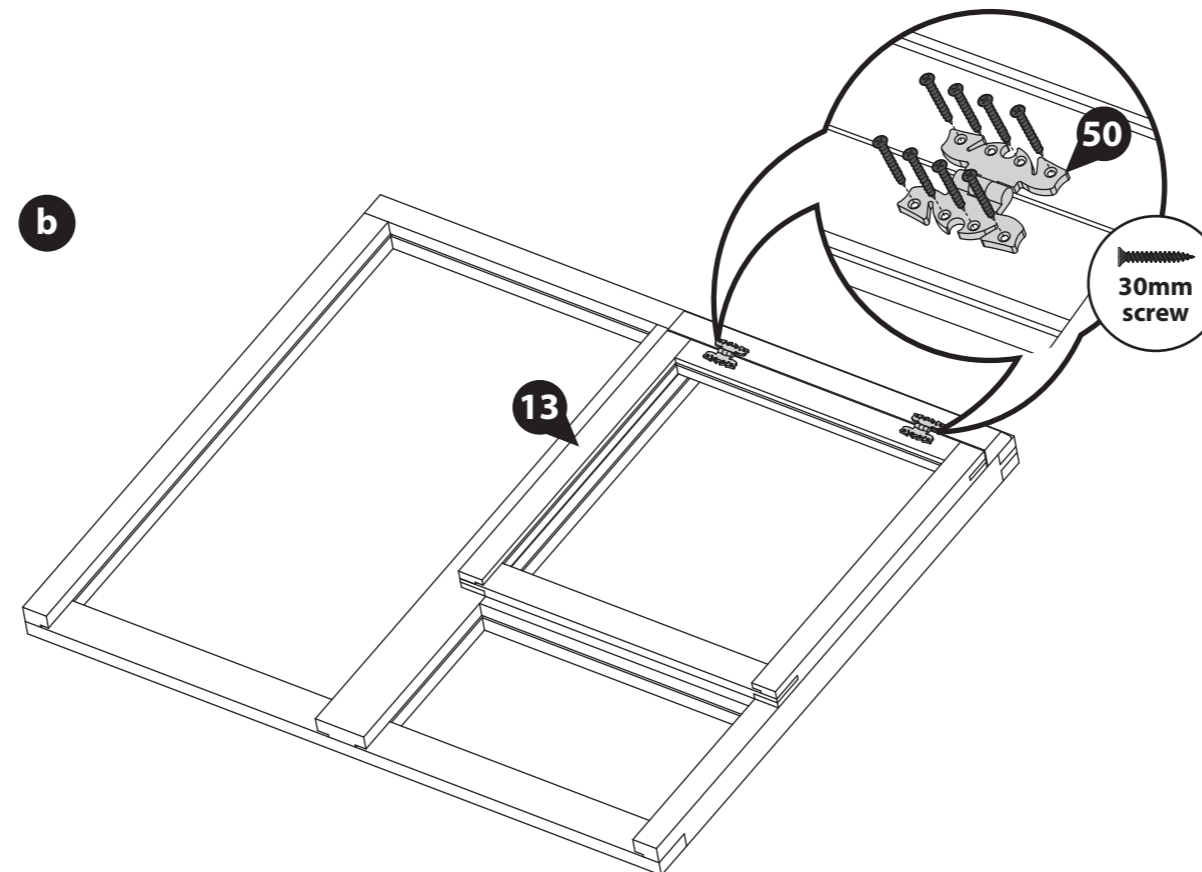
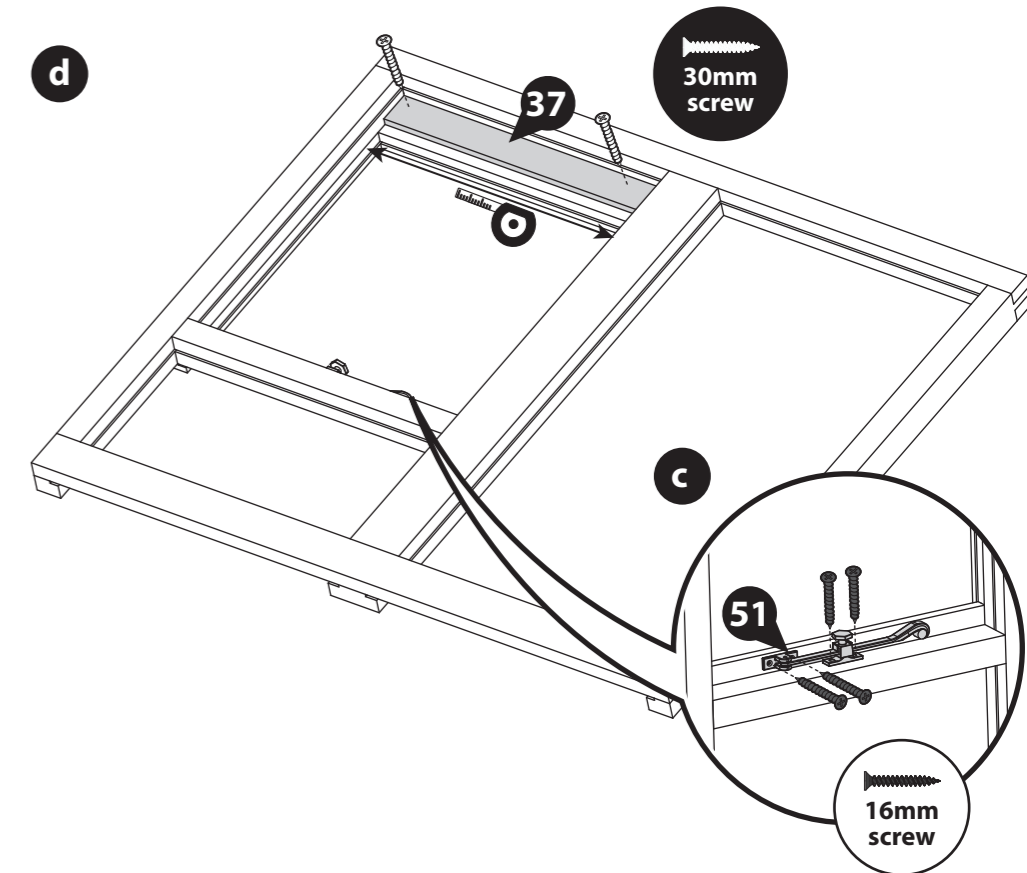
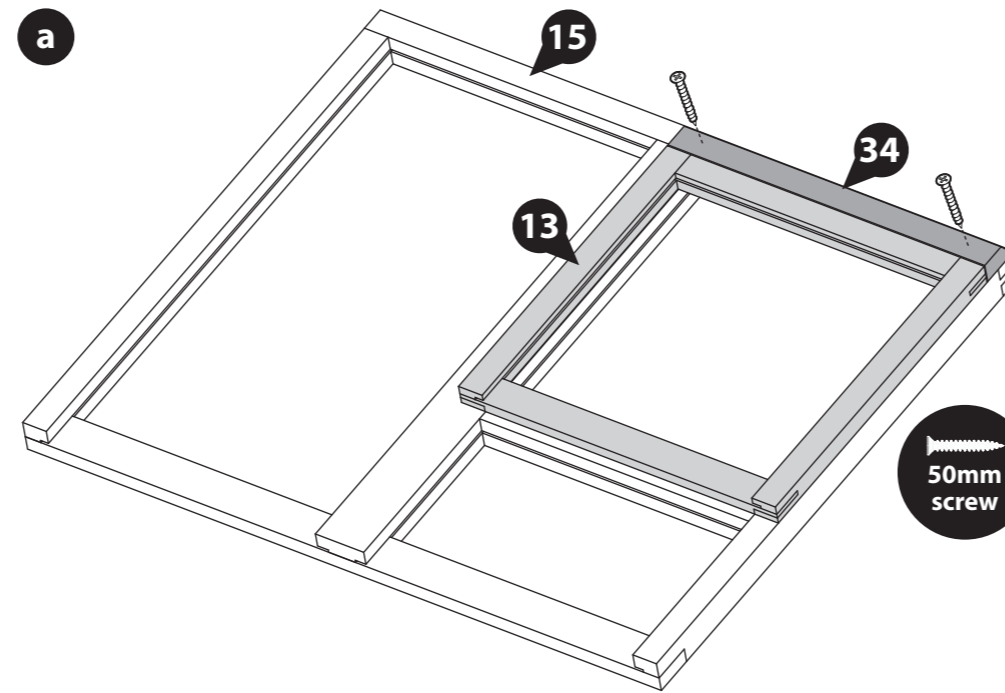

Pre drill holes



*Cut to fit

IMPORTANT: Pre-drill before fixing screws.

Step 41

Parts Needed

Building	No. 14	No. 15	No. 16	70mm screw
10x6	QTY 1	QTY 1	-	QTY 12
12x6	QTY 1	QTY 1	QTY 2	QTY 20
14x6	QTY 3	QTY 1	-	QTY 20

**Please note: The 4ft Roof Panels (No. 14 & 15) are interchangeable and can be positioned in a variety of different configurations.*

Where possible, we recommend positioning your opening window panel as central to the greenhouse as possible, as this will allow for the best ventilation.

- a** Starting at the end next to the shed, locate two Roof Panels (**No. 14, 15 or 16**) on either side of the central Ridge Bar, as shown. Ensure the Roofs sit flush and level with the shed roof, trapping the felt. The edges of the Roof Panels should meet flush at the Apex.

**Make sure to position your panels the correct way around. The stepped framing should be at the bottom, as shown.*

Fix the Roof Panels to the Shed Gable Top using 3x70mm screws per Roof, screwing through the bottom half of the Roof framing, into the Gable framing behind. Ensure to NOT screw into the Roof channel.

- b** Continue to Position the Roof panels (**No. 14, 15 or 16**) onto either side of the building, ensuring they are flush and level. Secure them together as you go using 4x70mm screws per join in an alternating pattern.

The last two roofs should sit to the inside of the Greenhouse Gable Top (**No. 12**) and the edges flush at the Apex. The Roof panels should sit approx 12mm above the Gable Top.

- c** Once all the Roof Panels are positioned, secure them to the Greenhouse Gable Top using 3x70mm screws per Roof.

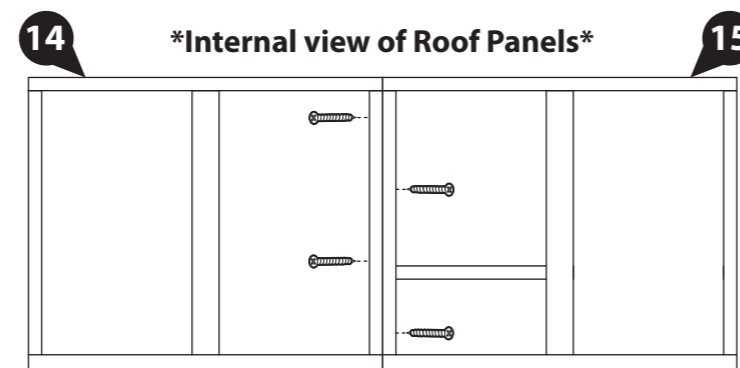
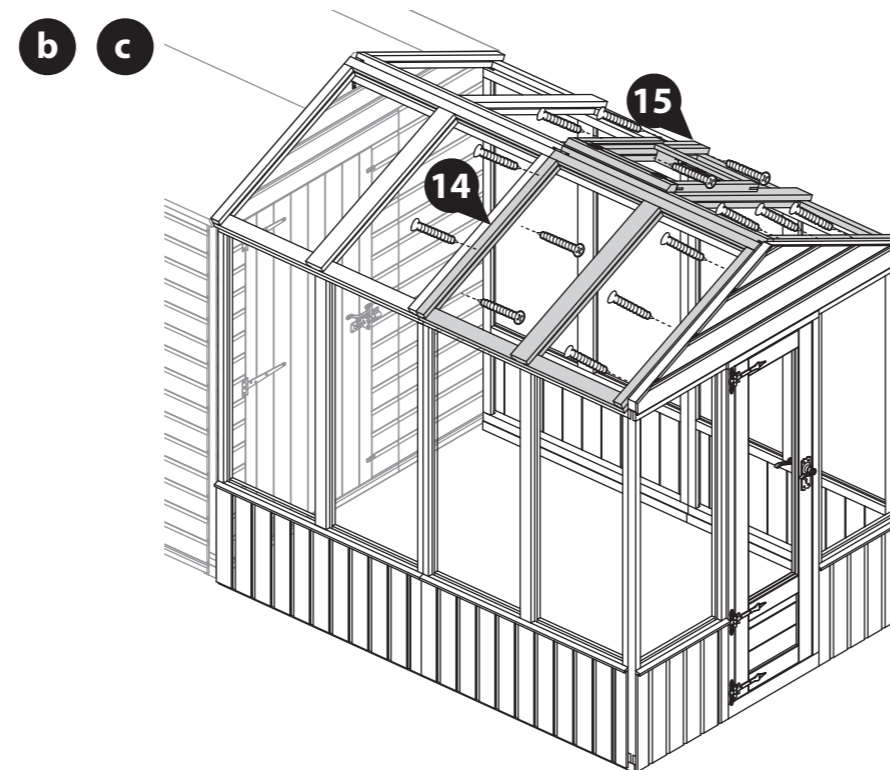
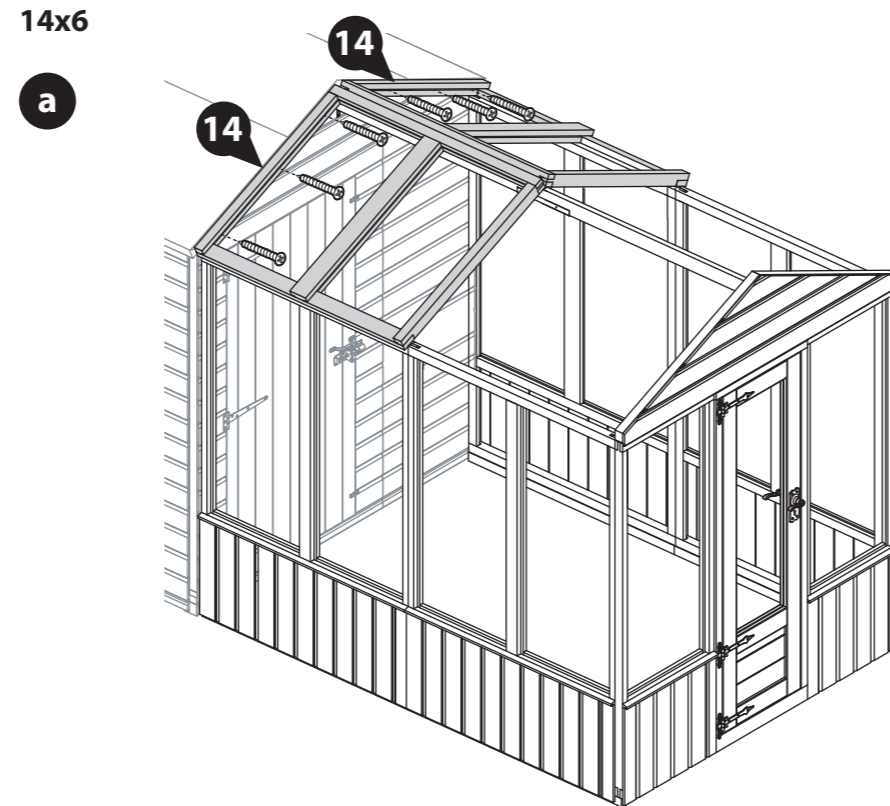
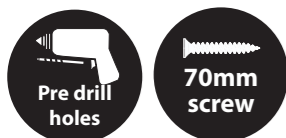

10x6

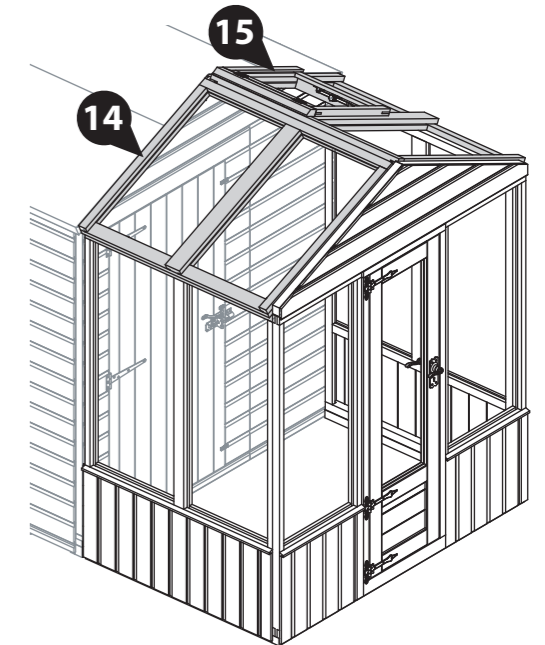

12x6

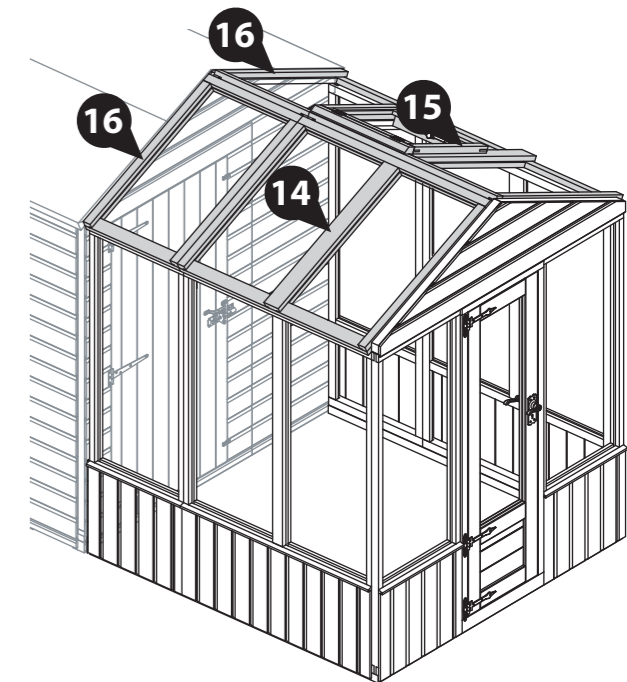

Step 42 **Parts Needed**

Building	70mm screw
10x6	QTY 4
12x6	QTY 6
14x6	QTY 8

Once the Roof Panels are in place, they can be fixed to the Ridge Bar.

Ensure to check that your Roof panels are level, flush and meet at the apex.

Internally, screw up at an angle through the Ridge Bar (**No. 22 and or 23**) into the Roof Panel (**No. 14, 15 or 16**) framing above using 2x70mm screws per 4ft Roof Panel, and 1x70mm screws per 2ft Roof Panel.

Ensure to stagger the screws to avoid collision.

It is essential that the Ridge Bar and Roof Panels pull together when secured. You may require another person pushing the Ridge Bar up from below when fixing to achieve this.

Please note: the 14x6 'Greenhouse door on the end, shed door on the inside' has been shown for illustrative purposes and may differ from your chosen configuration. However the process of fixing the Ridge Bars is the same for all.

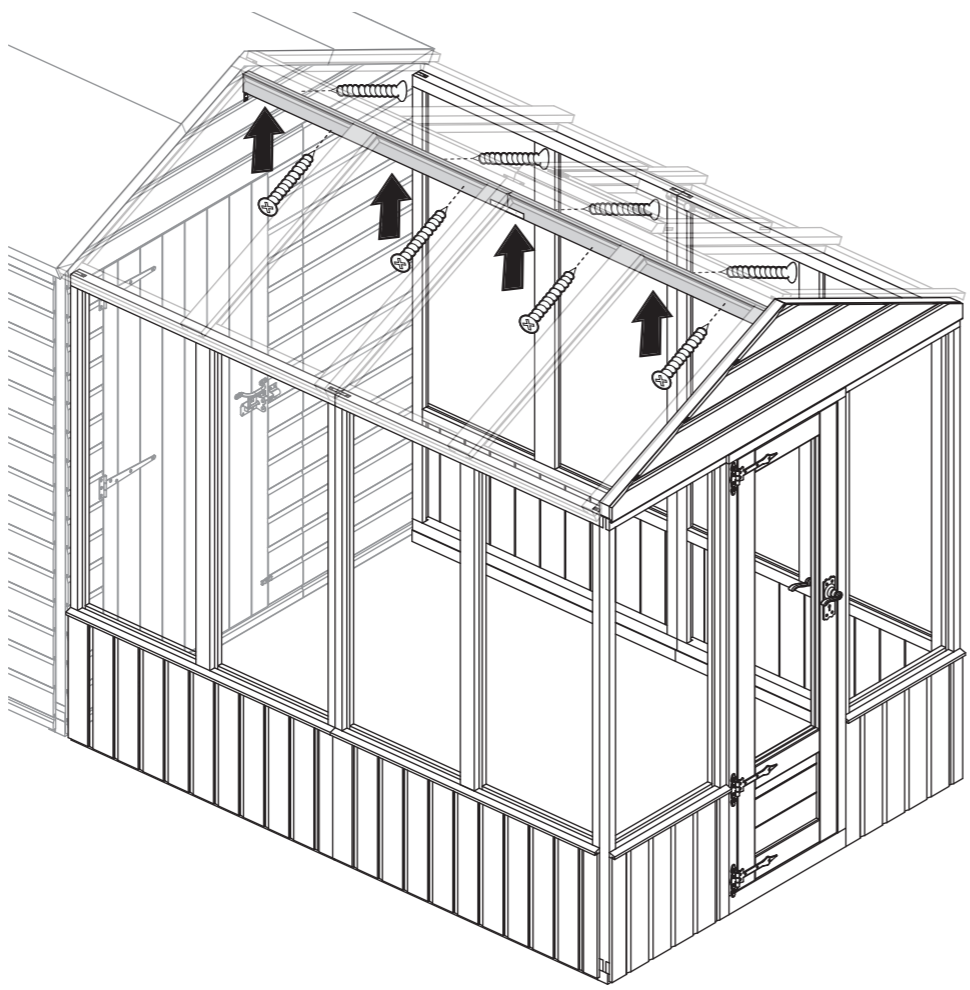
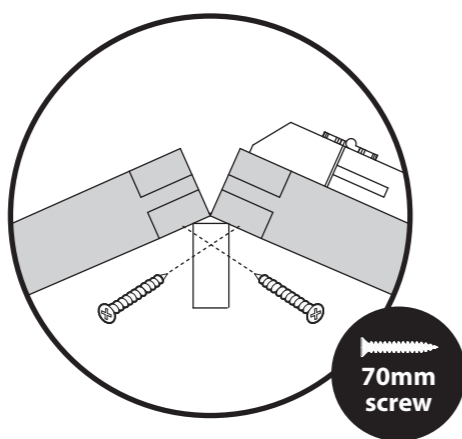

IMPORTANT: Pre-drill before fixing screws.

Step 43 **Parts Needed**

Building	No. 27	50mm screw
10x6	-	-
12x6	QTY 2	QTY 10
14x6	QTY 2	QTY 10

If you have purchased a 10x6 building, please skip past the truss assembly to Step 45.

On either side of the Ridge Bar where the Roofs join, position a Greenhouse Truss Frame (**No. 27**), underneath the Roof Panels (**No. 14, 15 or 16**) so they sit central to where the Roofs join, as shown.

Ensure to align the angled ends of the Greenhouse Truss Frame (**No. 27**) so they sit flush to the Wall Panel framing and flush to the Ridge Bar, as shown.

Fix the Greenhouse Truss Frame (**No. 27**) in place using 5x30mm screws per frame, screwing up through the Truss Frame (**No. 27**) into the Roof Panels (**No. 14, 15 or 16**).

It is essential that the Greenhouse Truss Frame (**No. 27**) and Roof Panels pull together when secured.

Please note: the 14x6 'Greenhouse door on the end, shed door on the inside' has been shown for illustrative purposes and may differ from your chosen configuration. However the process of fitting the Greenhouse Truss Frame is the same for all.

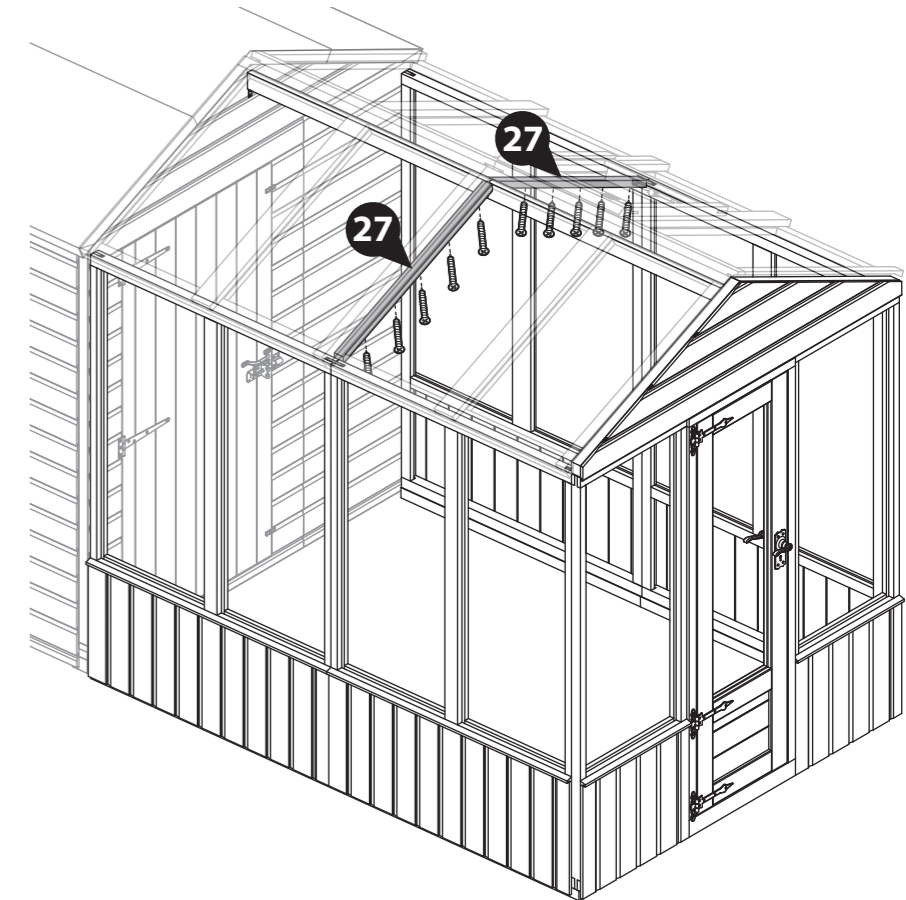

IMPORTANT: Pre-drill before fixing screws.

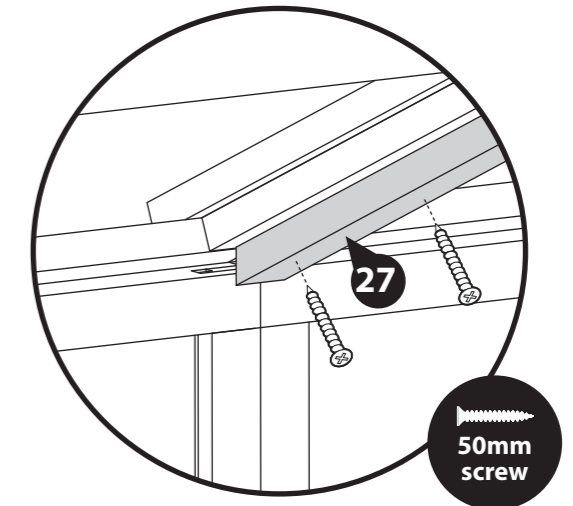

Internal View

Step 44 **Parts Needed**

Building	No. 29	50mm screw
10x6	-	-
12x6	QTY 2	QTY 4
14x6	QTY 2	QTY 4

If you have purchased a 10x6 building, please skip past the truss assembly to Step 45.

Place the Truss Block (No. 29) up to the Greenhouse Truss Frame (No. 27) so the angled cut edge is facing upwards, flush to the Truss Frame (No. 27).

Ensure the block is also flush to the Panel uprights behind.

Fix in place using 2x50mm screws through the block into the framing behind, alternating which Panel upright you screw in to, as shown.

Repeat on the opposite side of the building.

Please note: the 14x6 'Greenhouse door on the end, shed door on the inside' has been shown for illustrative purposes and may differ from your chosen configuration. However the process of fitting the Truss Block is the same for all.

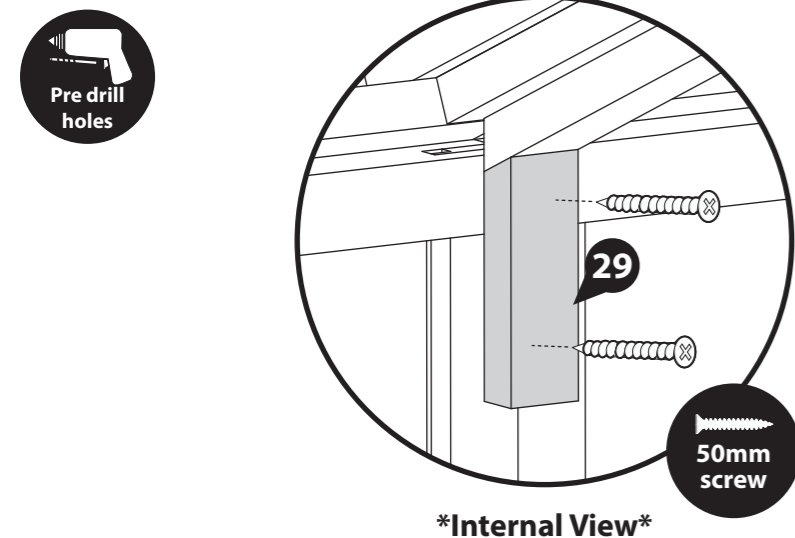

IMPORTANT: Pre-drill before fixing screws.

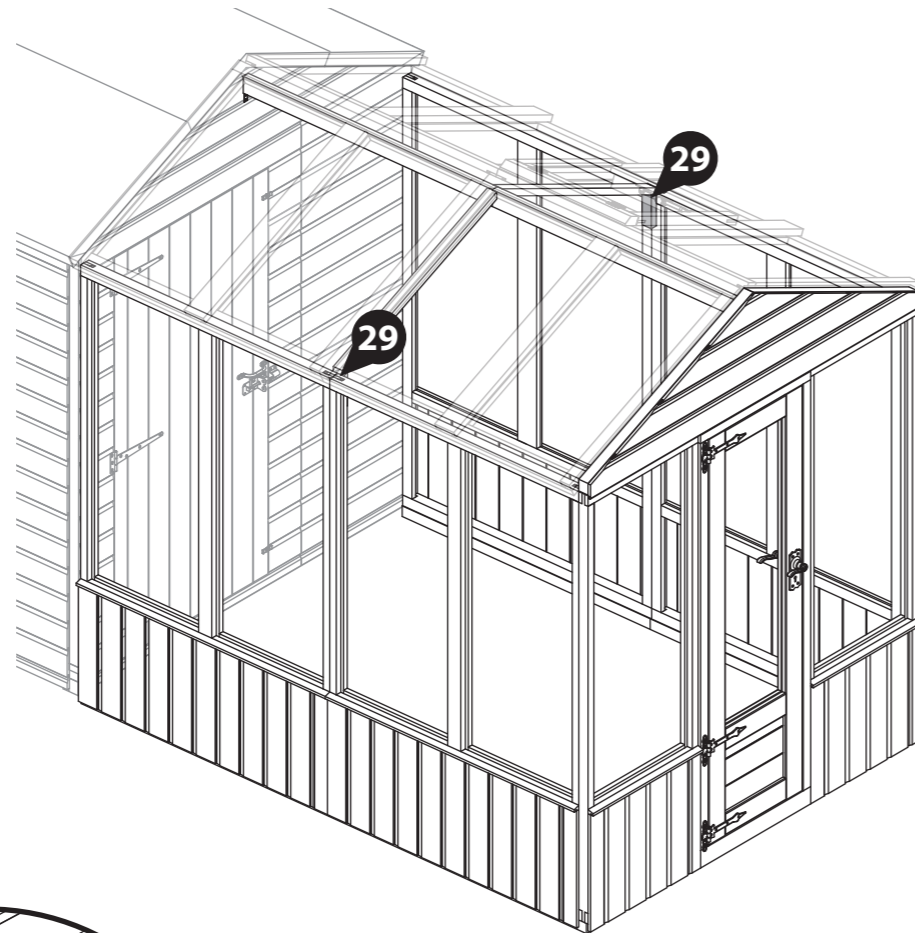

Step 45 **Parts Needed**

Building	No. 27	50mm screw
All sizes	QTY 2	QTY 10

On either side of the Ridge Bar where the Greenhouse Roofs sit up to the Shed Gable, position a Greenhouse Truss Frame (No. 27), underneath the Roof Panels (No. 14, 15 or 16) so they sit flush up to the Shed Gable Top, as shown.

Fix in place using 5x50mm screws per frame, screwing through the Truss Frame into the Gable cladding behind.

Ensure to align the angled ends of the Greenhouse Truss Frames (No. 27) so they sit flush to the wall Panel framing and flush to the Ridge Bar, as shown.

Please note: the 14x6 'Greenhouse door on the end, shed door on the inside' has been shown for illustrative purposes and may differ from your chosen configuration. However the process of fitting the Greenhouse Truss Frame is the same for all.

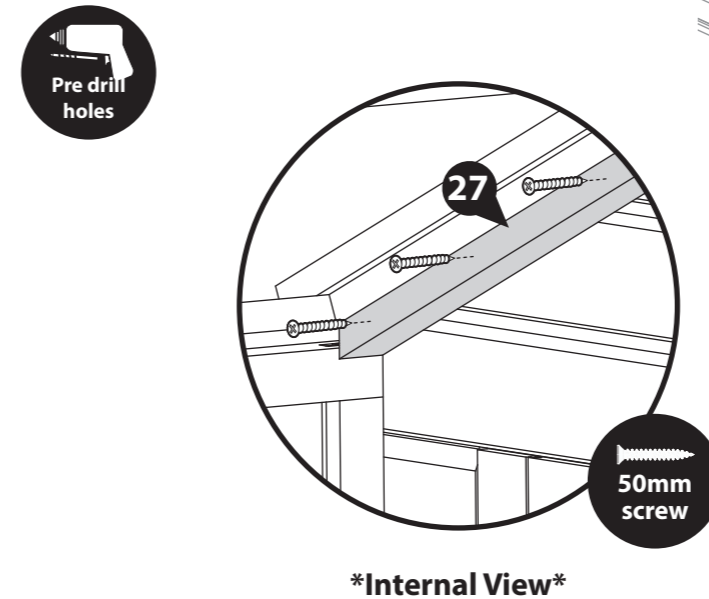

IMPORTANT: Pre-drill before fixing screws.

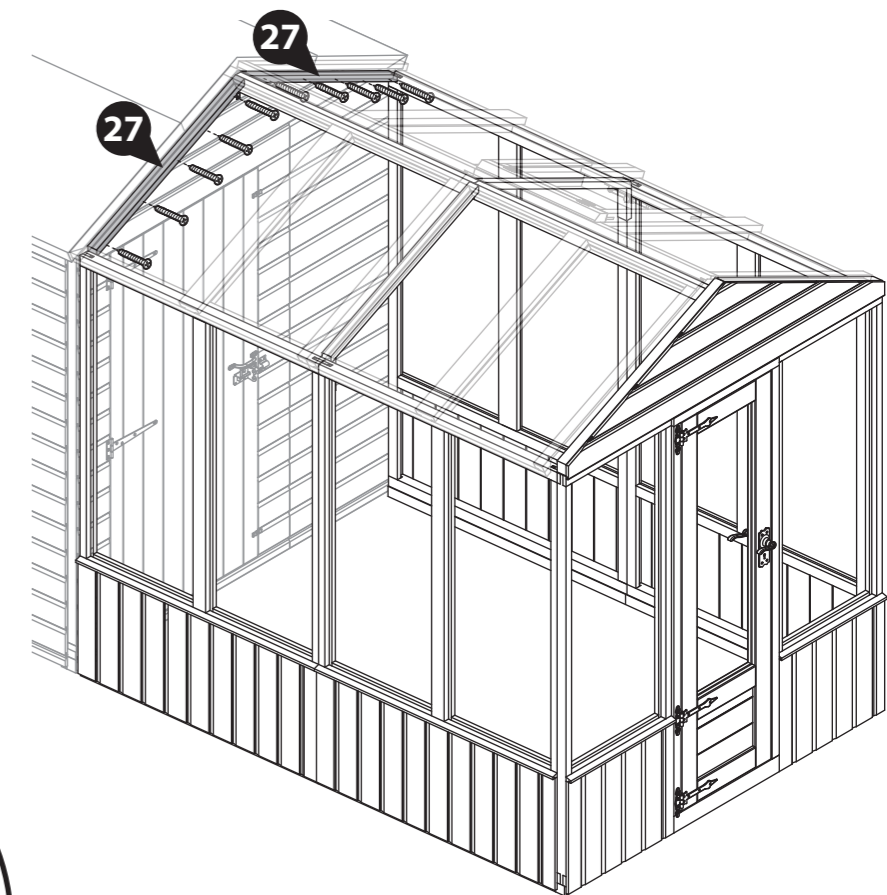

Step 46

Parts Needed

Building	No. 33	50mm screw
All sizes	QTY 2	QTY 8

Place the Wall Support (No. 33) up to the Greenhouse Truss Frame (No. 27) next to the Shed Gable top so the angled cut edge is facing upwards, flush to the Truss Frame (No. 27).

Ensure the support is also flush to the Panel uprights behind.

Fix in place using 4x50mm screws through the support into the wall Panel framing behind.

****Please note: The Wall Support may need cutting to size. If the frame cannot sit flush to your flat and level base, then it should sit flat to the base framing.**

Repeat on the opposite side of the building.

Please note: the 14x6 'Greenhouse door on the end, shed door on the inside' has been shown for illustrative purposes and may differ from your chosen configuration. However the process of fitting the Wall Support is the same for all.

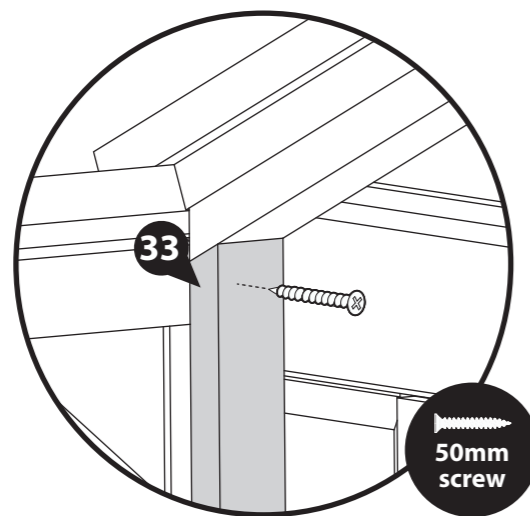
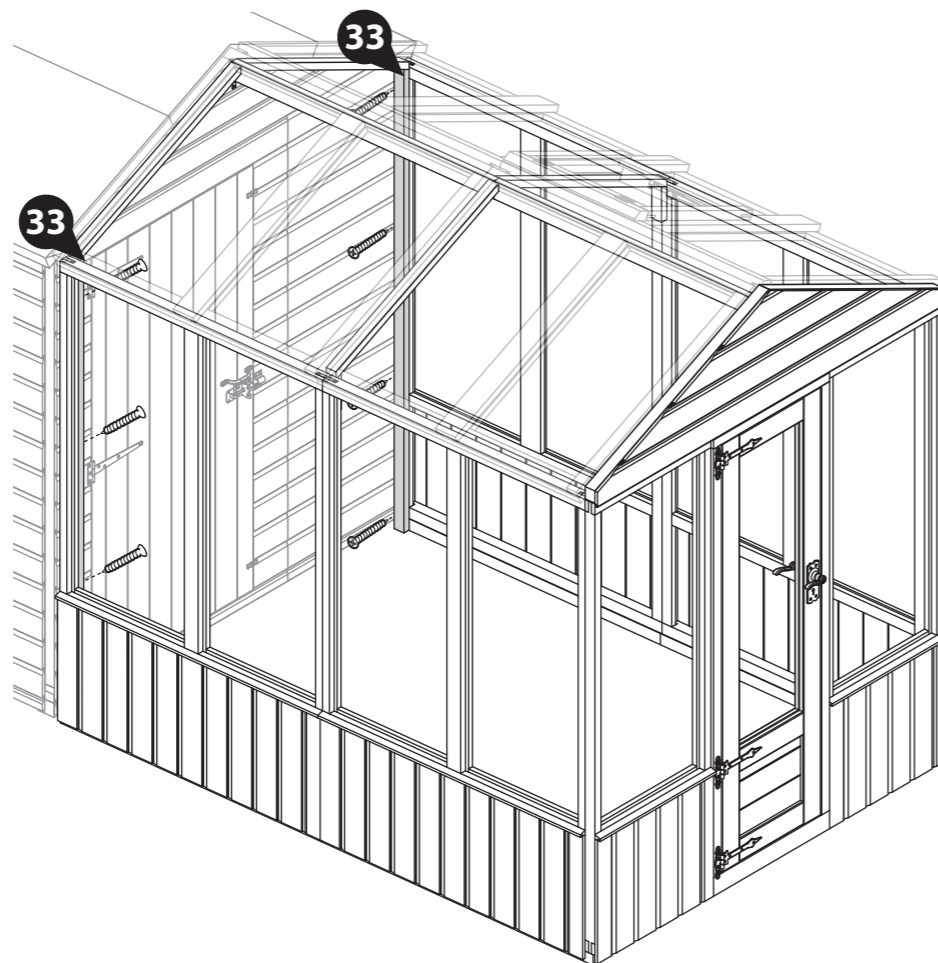

Internal View

IMPORTANT: Pre-drill before fixing screws.

Step 47

Parts Needed

Building	No. 30	40mm screw
10x6	QTY 1	QTY 4
12x6	QTY 2	QTY 8
14x6	QTY 2	QTY 8

Place one Truss Support (No. 30) underneath each set of Greenhouse Truss Frames (No. 27) ensuring they sit flush to both frames, as shown.

The Truss Support (No. 30) should sit horizontal - parallel to the floor.

Once in position fix the Truss Supports (No. 30) in place using 2x40mm screws at each end of the truss.

Please note: the 14x6 'Greenhouse door on the end, shed door on the inside' has been shown for illustrative purposes and may differ from your chosen configuration. However the process of fitting the Truss Support is the same for all.

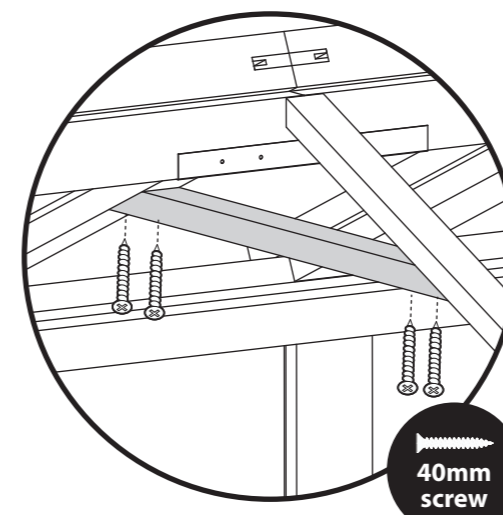

Internal View

IMPORTANT: Pre-drill before fixing screws.

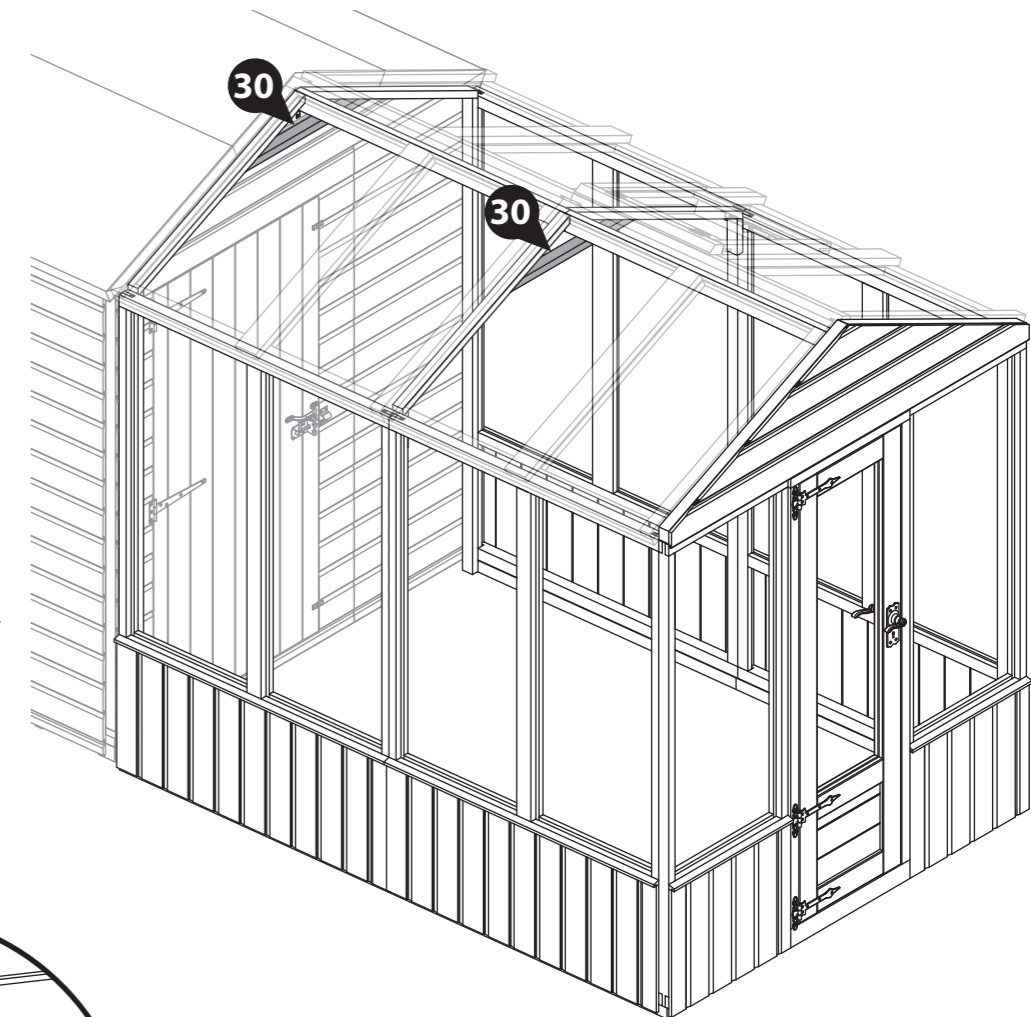

Step 48

Parts Needed

Building	50mm screw
10x6	QTY 8
12x6	QTY 12
14x6	QTY 16

Make sure the Greenhouse section of the building is square by measuring from corner to corner and comparing the measurements. If the measurements are equal, the building is square, if not, adjustments may be required.

Once square, secure the Roofs in place using 50mm screws, screwing down through the Roof framing into the Panel framing below.

Ensure the screws are countersunk to avoid interference when glazing.

Please note: the 14x6 'Greenhouse door on the end, shed door on the inside' has been shown for illustrative purposes and may differ from your chosen configuration. However the process of fixing the Roof is the same for all.



IMPORTANT: Pre-drill before fixing screws.

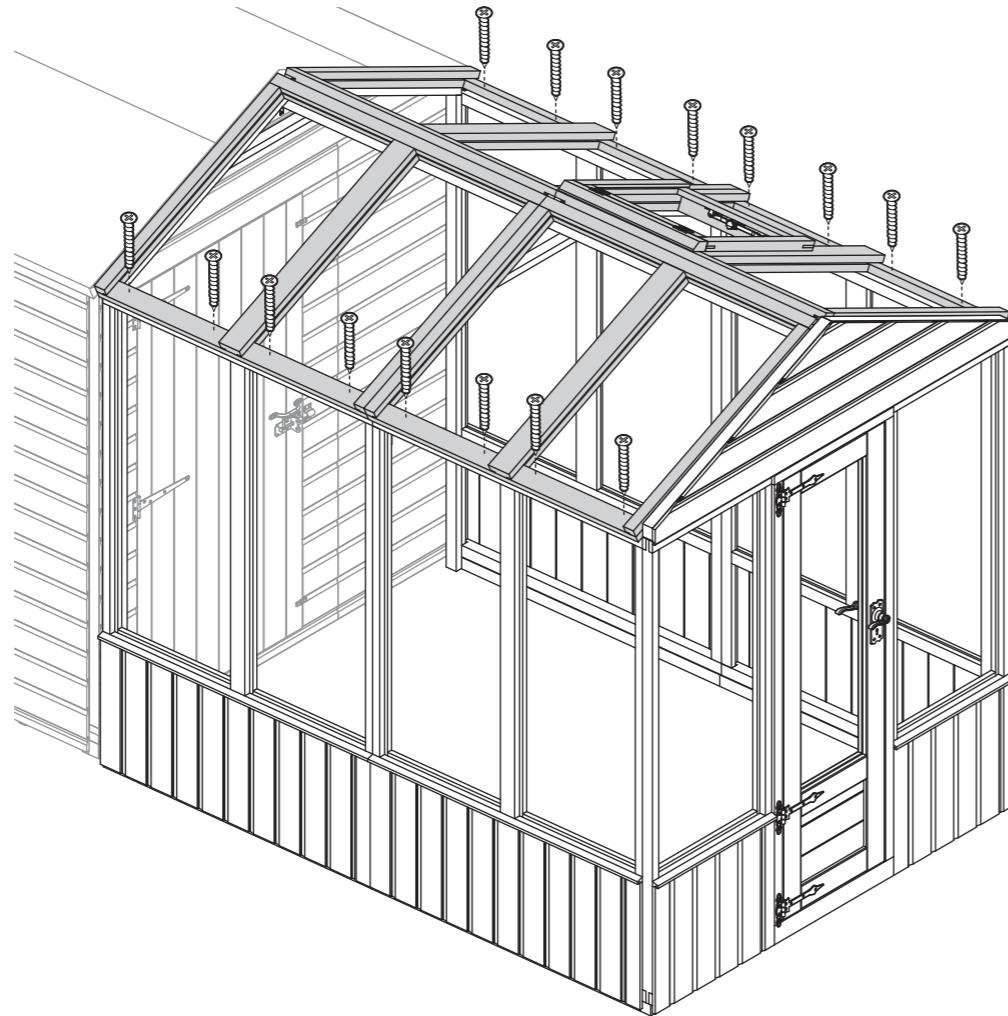

Step 49

Parts Needed

Building	70mm screw
10x6	QTY 12
12x6	QTY 16
14x6	QTY 18

Once the Roof is fixed, secure the Panels to the base frame using 70mm screws, screwing down through the Panel framing into the base frame below.

Please note: the 14x6 'Greenhouse door on the end, shed door on the inside' has been shown for illustrative purposes and may differ from your chosen configuration. However the process of fixing the Panels is the same for all.



C

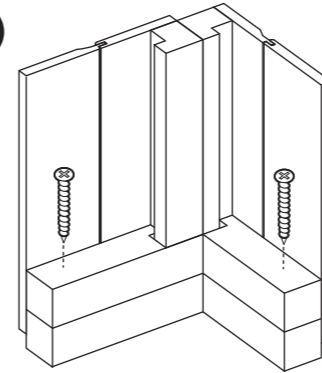

IMPORTANT: Pre-drill before fixing screws.

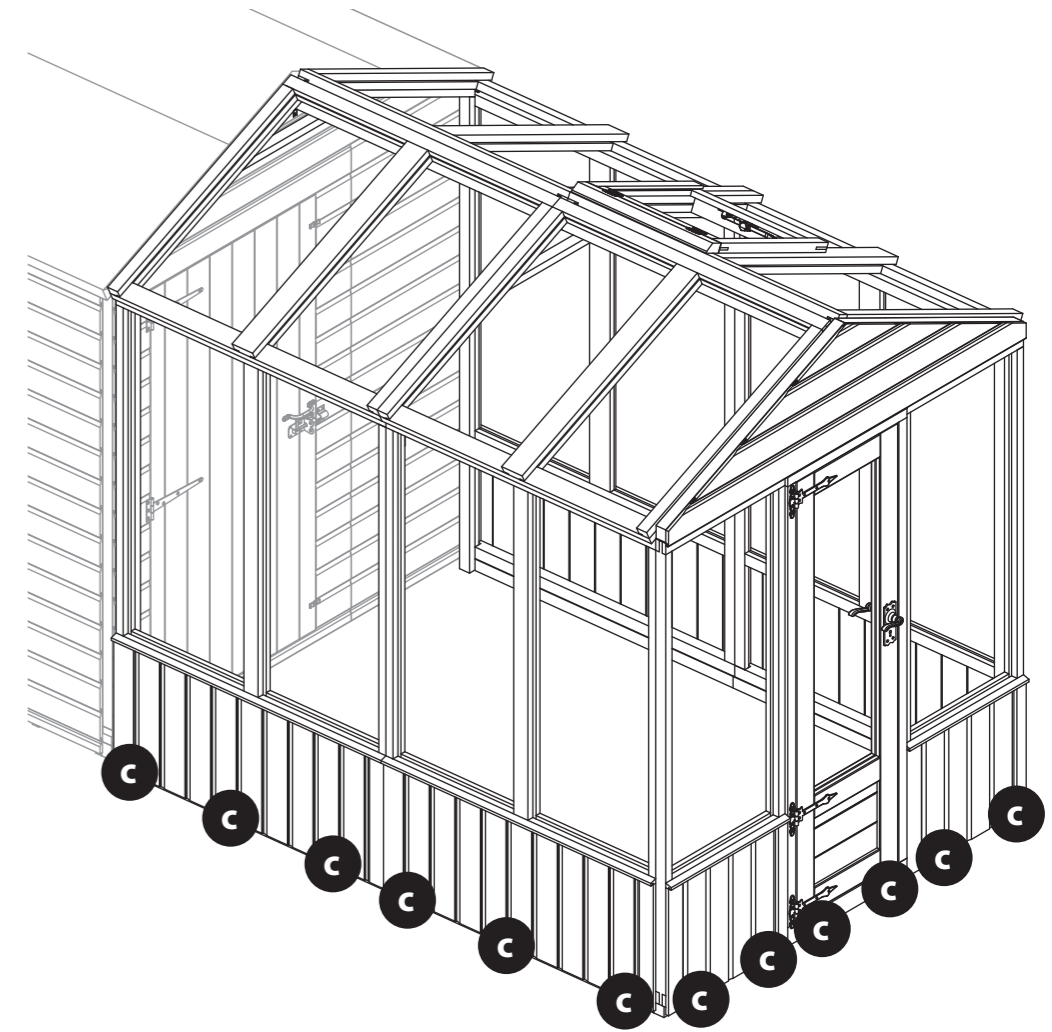

Step 50 Parts Needed

Building	No. 35	No. 36	50mm screw
10x6	-	QTY 1	QTY 4
12x6	QTY 1	-	QTY 4
14x6	-	QTY 2	QTY 8

Position the Roof Supports (**No. 35 or 36**) at the top of the Apex, in-between the Roof Panels. Ensure the Supports are flush to the inside of the Gables and the cut outs sit on the top of the Roof Panels, as shown.

Secure in place using 4x50mm screws per Roof Support, screwing at an angle through the top of the support into the Roof Panel behind. Alternate screws to avoid collision.

Please note: the 14x6 'Greenhouse door on the end, shed door on the inside' has been shown for illustrative purposes and may differ from your chosen configuration. However the process of fitting the Roof Support is the same for all.



IMPORTANT: Pre-drill before fixing screws.

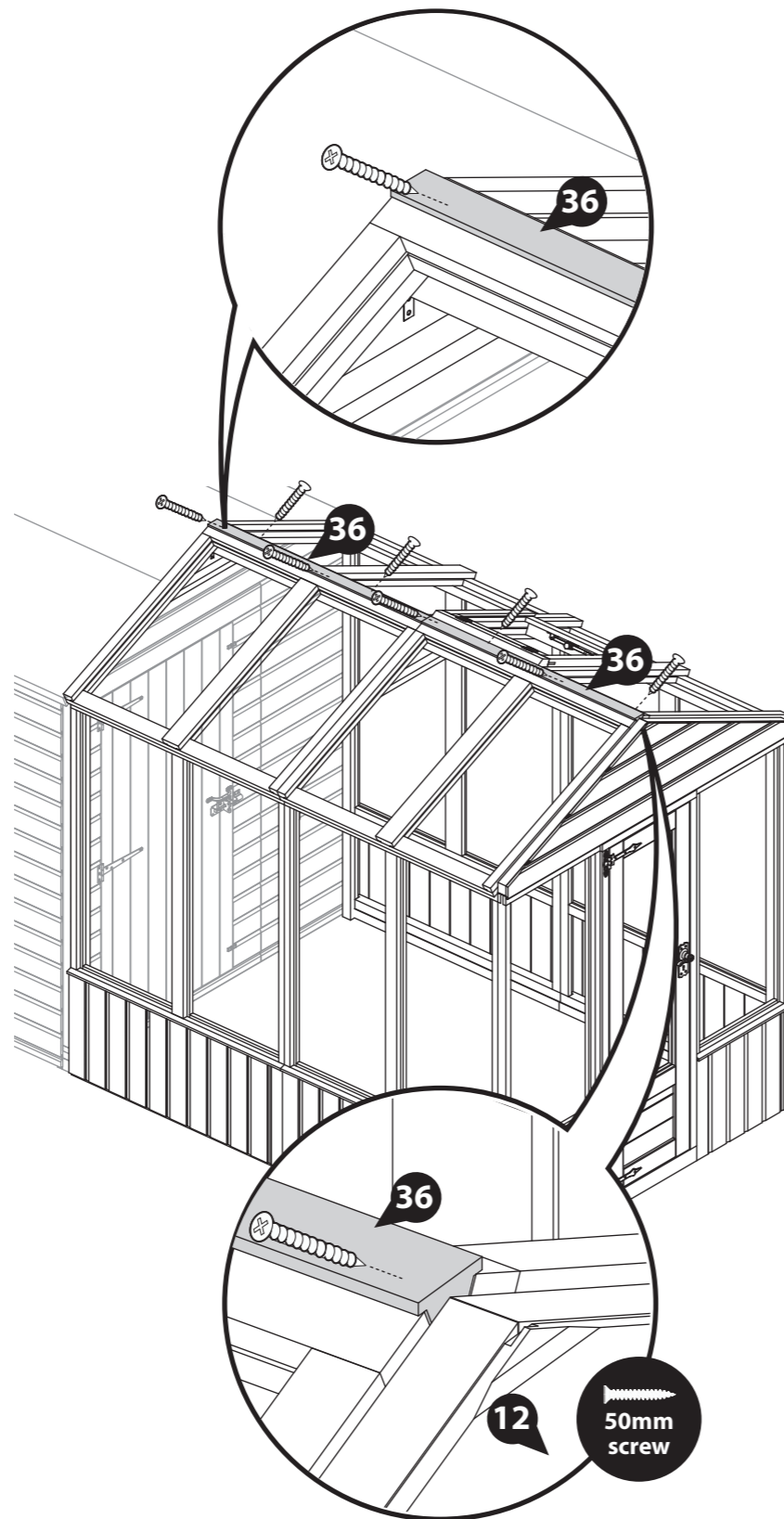

Step 51 Parts Needed

Building	No. 37	30mm screw
10x6	QTY 10	QTY 30
12x6	QTY 12	QTY 42
14x6	QTY 12	QTY 42

Please note: You may not need to use all the Cover Trims (No. 37) you have been provided.

a At each corner and Panel join, use a tape measure to measure the distance the Cover Trim needs to fill e.g, from the bottom of the Panel to the top of the Panel or from the top of the cill to the top of the panel.

Mark the measurements onto the Cover Trims (**No. 37**) and cut to size if required.

Please note: Ensure to use all of one Cover Trim where possible before cutting a new one. Do not dispose of off-cuts until the building is fully constructed as they may be needed in another step.

b Locate the Cover Trims (**No. 37**), over each Panel join and corner, ensuring they sit centrally over the joins and flush to the Panel cladding at the corners.

Secure in place using 3x30mm screws per Cover Trim, alternating fixing into each Panel when over a join.

Please note: the 14x6 'Greenhouse door on the end, shed door on the inside' has been shown for illustrative purposes and may differ from your chosen configuration. However the process of fitting the Cover Trims is the same for all.



IMPORTANT: Pre-drill before fixing screws.

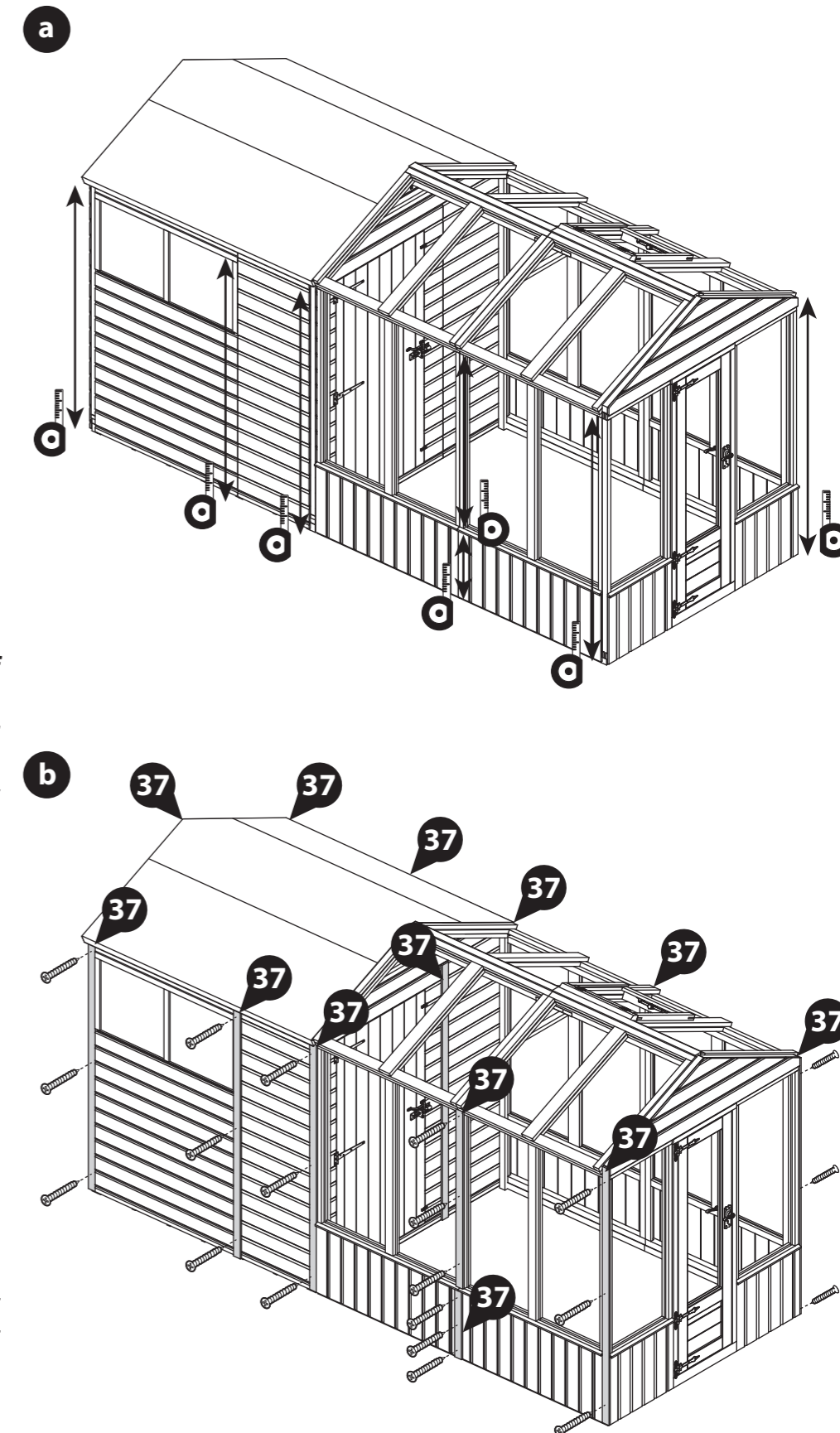

IMPORTANT: Pre-drill before fixing screws.

Step 52	Parts Needed	
Building	No. 37	30mm screw
All sizes	QTY 1	QTY 6

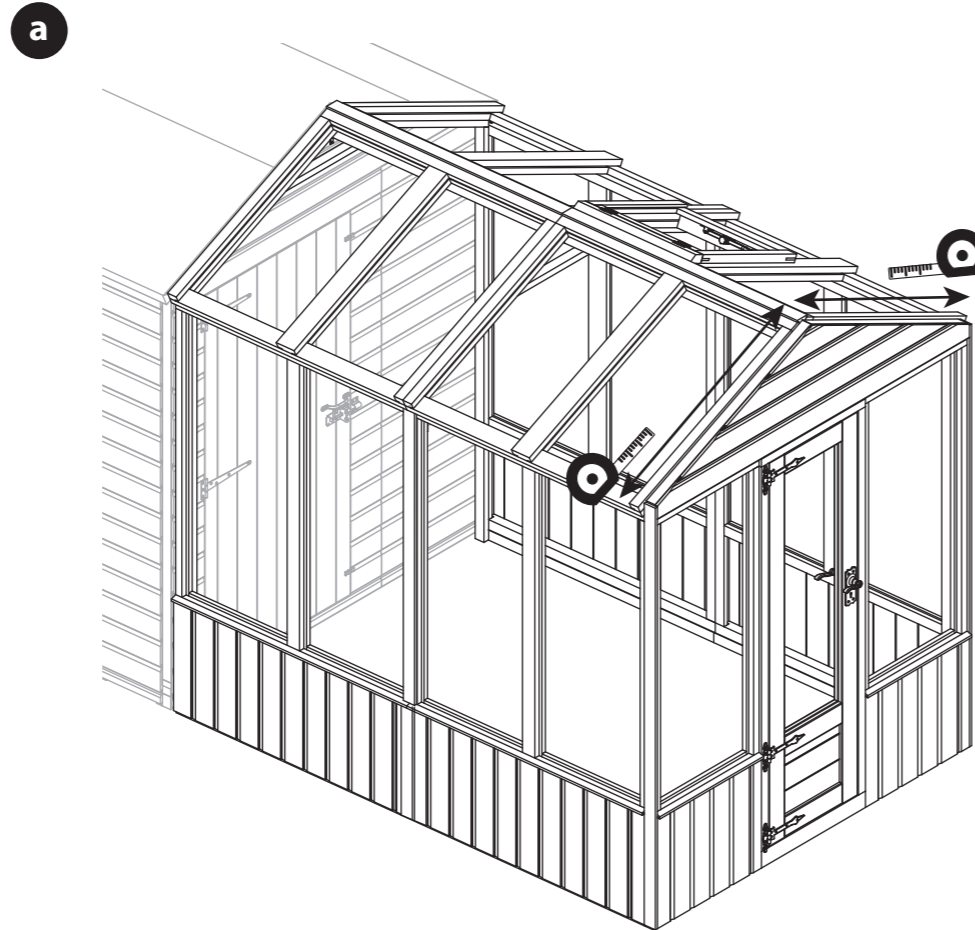

a On the Greenhouse Gable Top, use a tape measure to measure the distance from the top of the apex to the bottom of the Roof Panel on either side, as shown.

Mark the measurements onto the Cover Trims (**No. 37**) and cut to size if required.

Please note: One Cover Trim can be cut to create both sizes for the Gable end. Ensure to use all of one Cover Trim where possible before cutting a new one. Do not dispose of off-cuts until the building is fully constructed as they may be needed in another step.

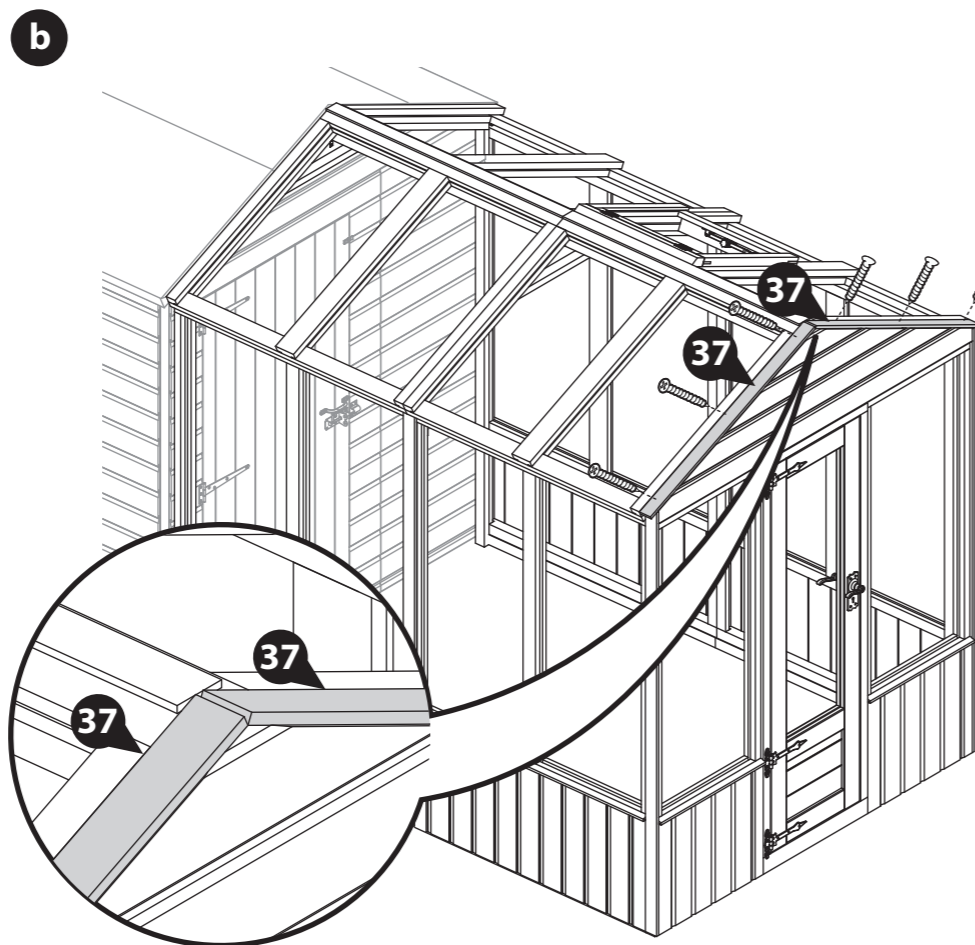

b Locate the Cover Trims (**No. 37**), over the exposed framing on the Gable, ensuring they sit flush to the cladding and meet at the apex, as shown.

Secure in place using 3x30mm screws per Cover Trim.

Please note: the 14x6 'Greenhouse door on the end, shed door on the inside' has been shown for illustrative purposes and may differ from your chosen configuration. However the process of fitting the Cover Trims is the same for all.



IMPORTANT: Pre-drill before fixing screws.

Step 53

Parts Needed

Building	No. 38	30mm screw
All sizes	QTY 2	QTY 12

- a** At the Greenhouse Gable end and where the buildings join, measure the distance from the side of the Roof Support (**No. 35 and/or 36**) to the bottom of the Roof Panels on either side.

Mark the measurements onto the Roof Trims (**No. 38**) and cut to size.

Please note: One Roof Trim can be cut to create both sizes for one end. Ensure to use all of one Roof Trim where possible before cutting a new one.

- b** At the Greenhouse end, locate the Roof Trims (**No. 38**) centrally over the previously fitted Cover Trim and Roof framing.

Where the buildings join, position the Roof Trims (**No. 38**) centrally over the joining Roof panels.

Secure in place using 3x30mm screws per Roof Trim, ensuring to stagger the screws to avoid them colliding with the ones below.

10x6 only:

Measure and cut a notch out of the Roof Trim next to the opening window to ensure a neat finish, as shown in the close up illustration below.

Please note: the 14x6 'Greenhouse door on the end, shed door on the inside' has been shown for illustrative purposes and may differ from your chosen configuration. However the process of fitting the Roof Trims is the same for all.



10x6 only

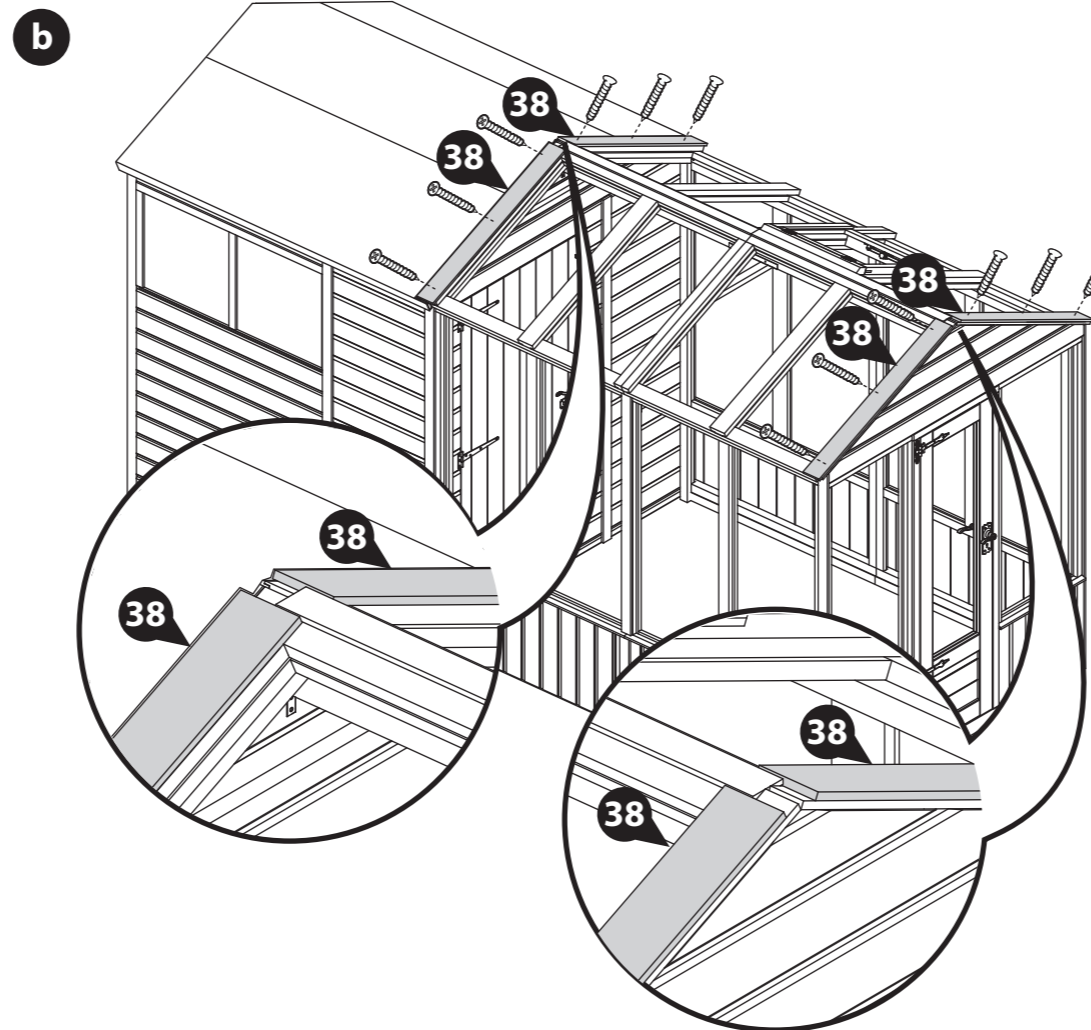
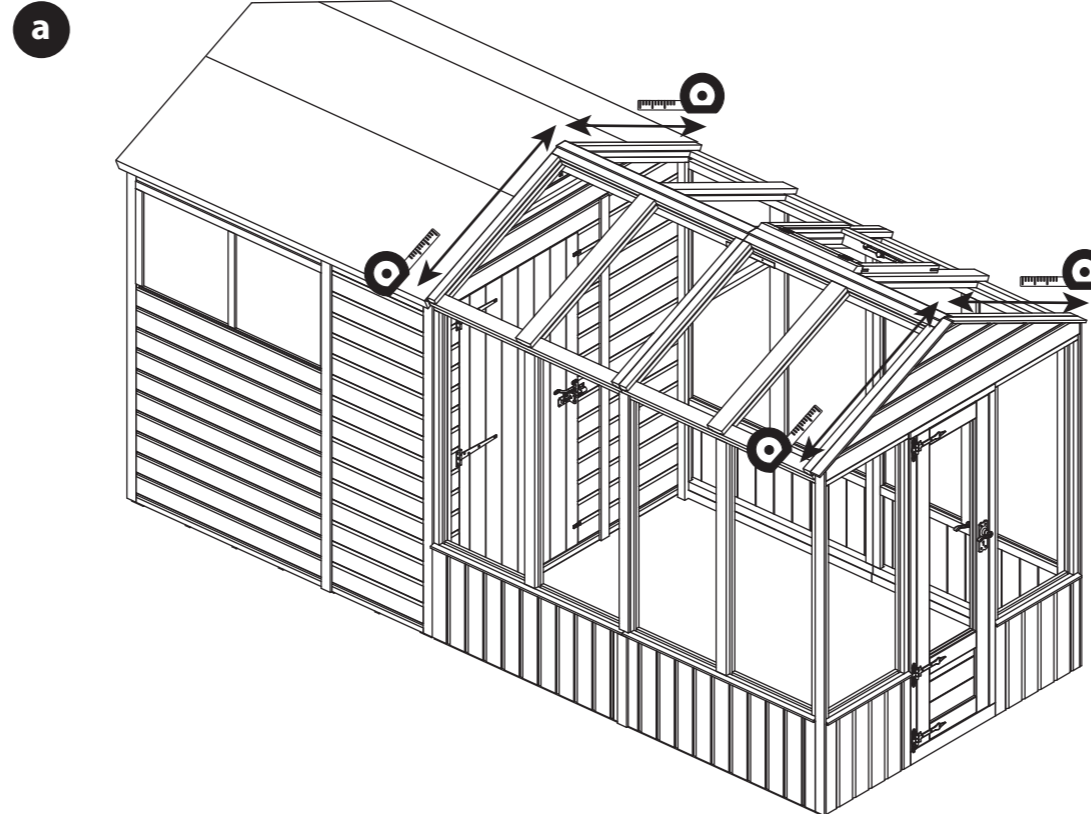
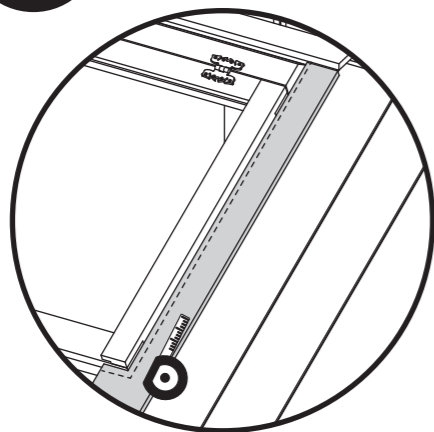

Step 54	Parts Needed	
Building	No. 40	30mm screw
10x6	QTY 1	QTY 3
12x6	QTY 1	QTY 3
14x6	QTY 2	QTY 6

IMPORTANT: Pre-drill before fixing screws.

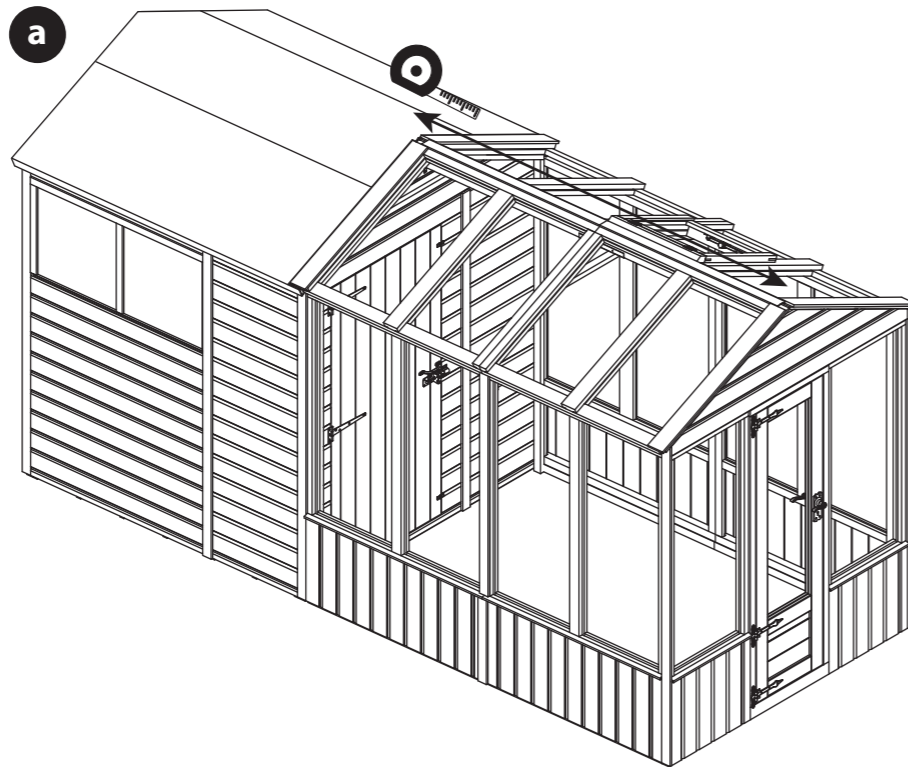

a At the Greenhouse Gable end of the building, measure the distance from the front of the building to the end of the Roof Trims previously fitted, as shown.

b Lay the Roof Covers (No. 40) out end-to-end so they are flush and level, and mark the total measurement onto the Roof Covers, as shown.

Use a saw to remove the excess material.

c Position the cut down Roof Covers (No. 40), centrally on top of the Roof Support framing (No. 35 and/or 36). Ensure the Roof Cover finishes flush with the Roof Trims (No. 38) at either end.

Secure in place using 3x30mm screws per Roof Cover, ensuring to stagger the screws to avoid them colliding with the ones below.

Please note: the 14x6 'Greenhouse door on the end, shed door on the inside' has been shown for illustrative purposes and may differ from your chosen configuration. However the process of fitting the Roof Covers is the same for all.

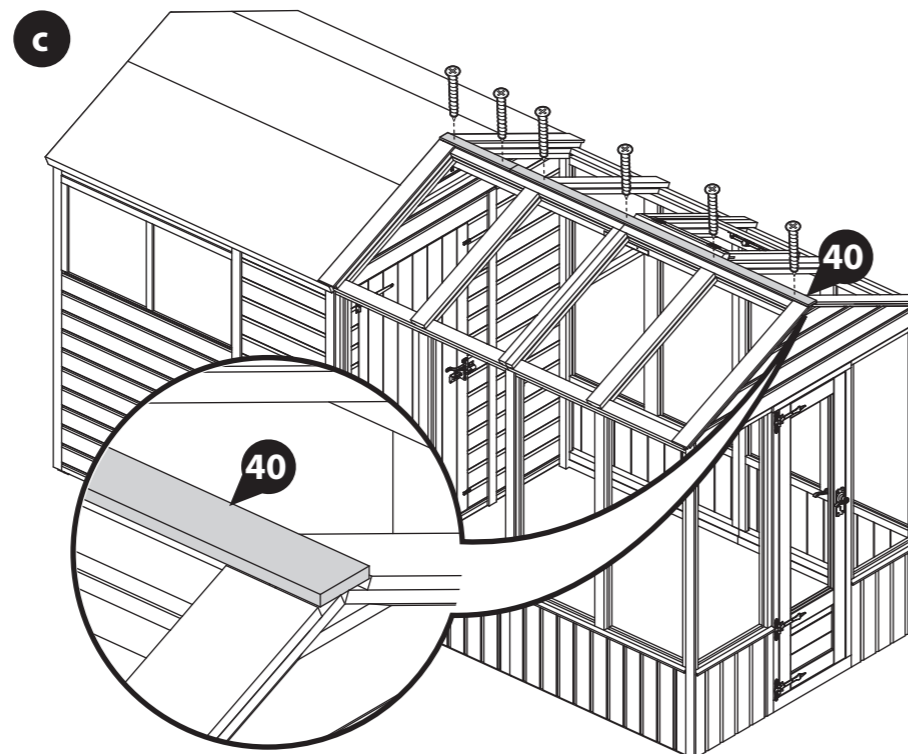
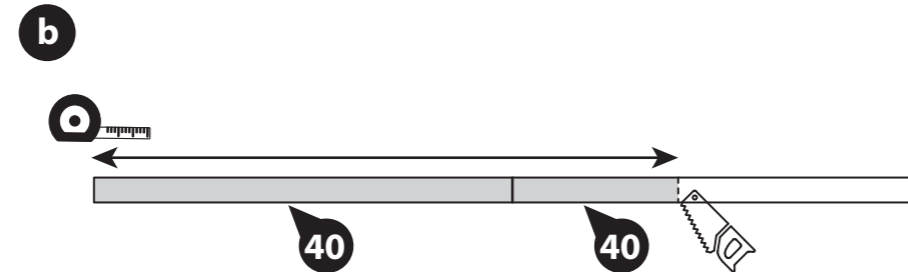

Step 55	Parts Needed		
Building	No. 39	No. 56	40mm screw
All sizes	QTY 4	QTY 2	QTY 16

IMPORTANT: Pre-drill before fixing screws.

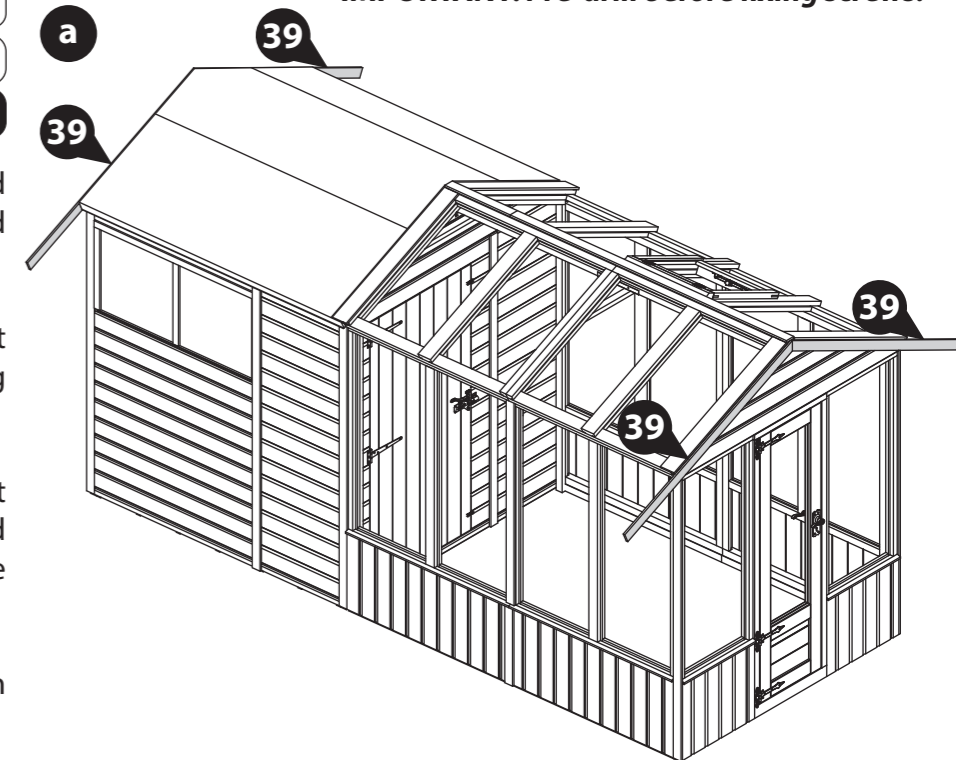

a Locate two Fascias (No. 39), to each end of the building, making sure the angled ends meet at the top of the apex.

b The Fascias (No. 39) will overhang past the end of the Roofs - mark the overhang onto the Fascias using a pencil or tape.

To get a neat cut, align the pre-cut angled end of a Fascia with the mark and draw a line. Using a saw, remove the excess material.

c Re-position the Fascias and secure in place using 3x40mm screws per Fascia.

Position the Finials (No. 56) on top of the Fascias at either end of the building and secure in place using 2x40mm screws per Finial.

Please note: the 14x6 'Greenhouse door on the end, shed door on the inside' has been shown for illustrative purposes and may differ from your chosen configuration. However the process of fitting the Fascias is the same for all.

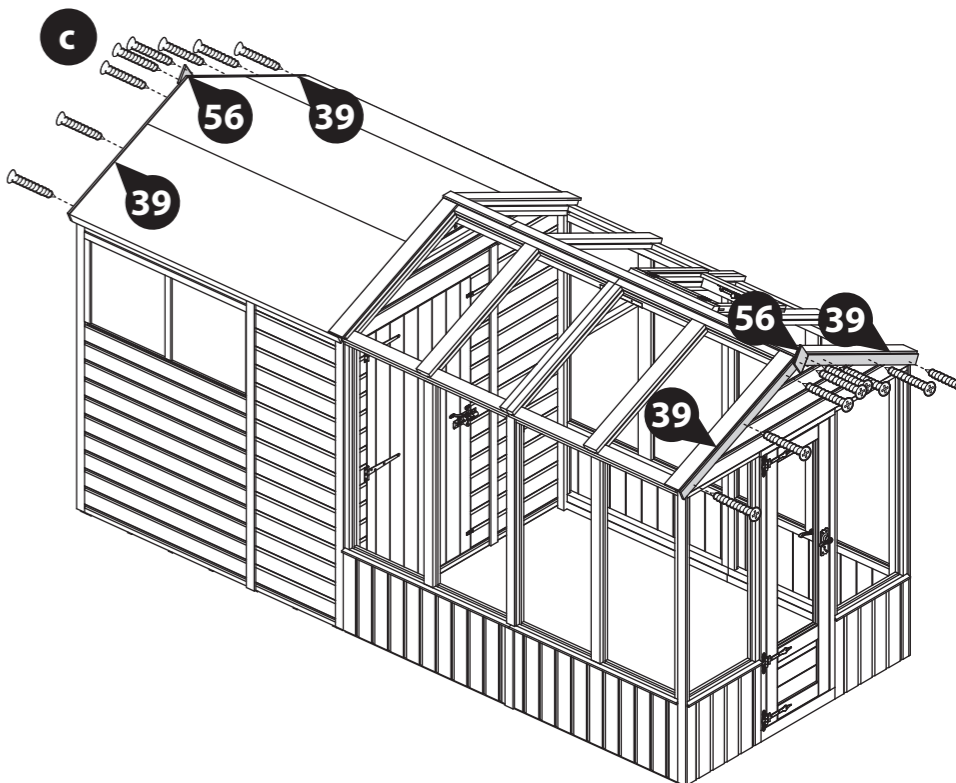
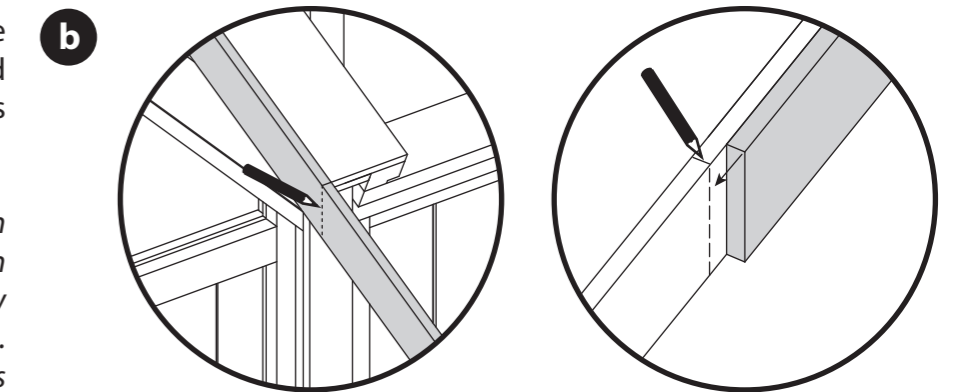

Step 56

Once constructed, apply a preserving treatment and a waterproofing treatment to your garden building as soon as possible. This will help to protect your building and prevent decay.

****Make sure to treat any loose timber components still required for the glazing of your building - such as beading strips.**

See page 46 for a full guide and instructions.

Once fully treated, gently score around the protective covers on the shed window and Greenhouse door glazing, then carefully peel the coverings back.

Please note: the 14x6 'Greenhouse door on the end, shed door on the inside' has been shown for illustrative purposes and may differ from your chosen configuration. However the process of treating the building is the same for all.



Apply treatment. Score and peel.

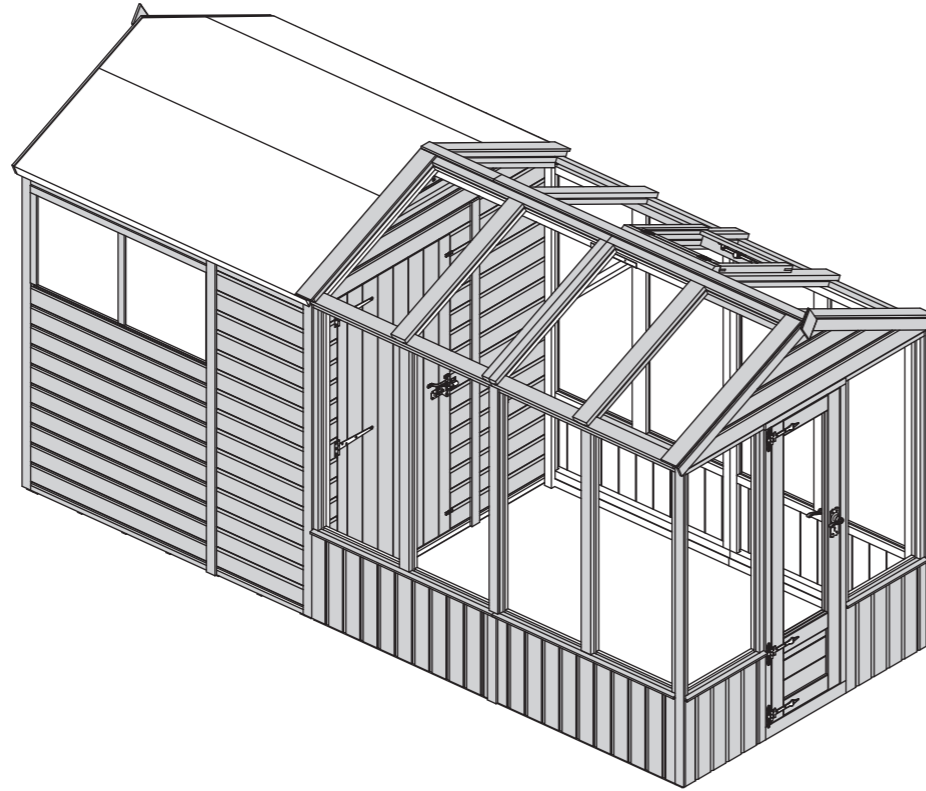
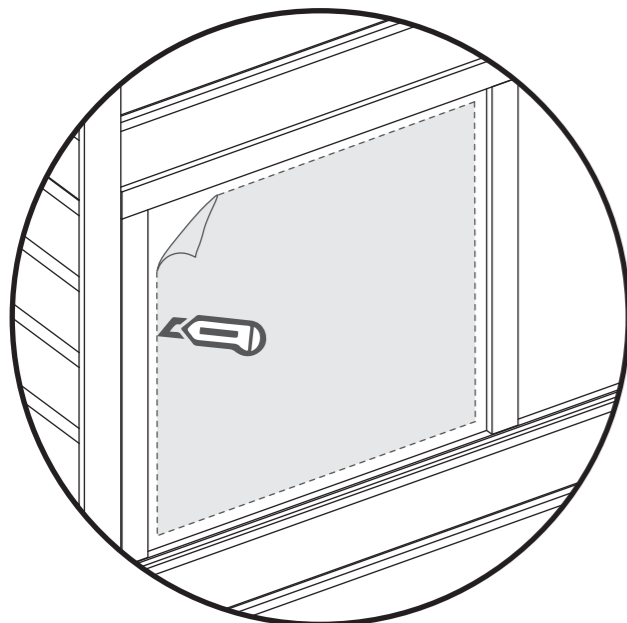

Next steps...

Once your building is constructed and treated, please refer to the 'Panel Glazing' manual provided for steps on how to fit the glazing to each of your panels.

This guide must be followed to complete the construction of your Building.

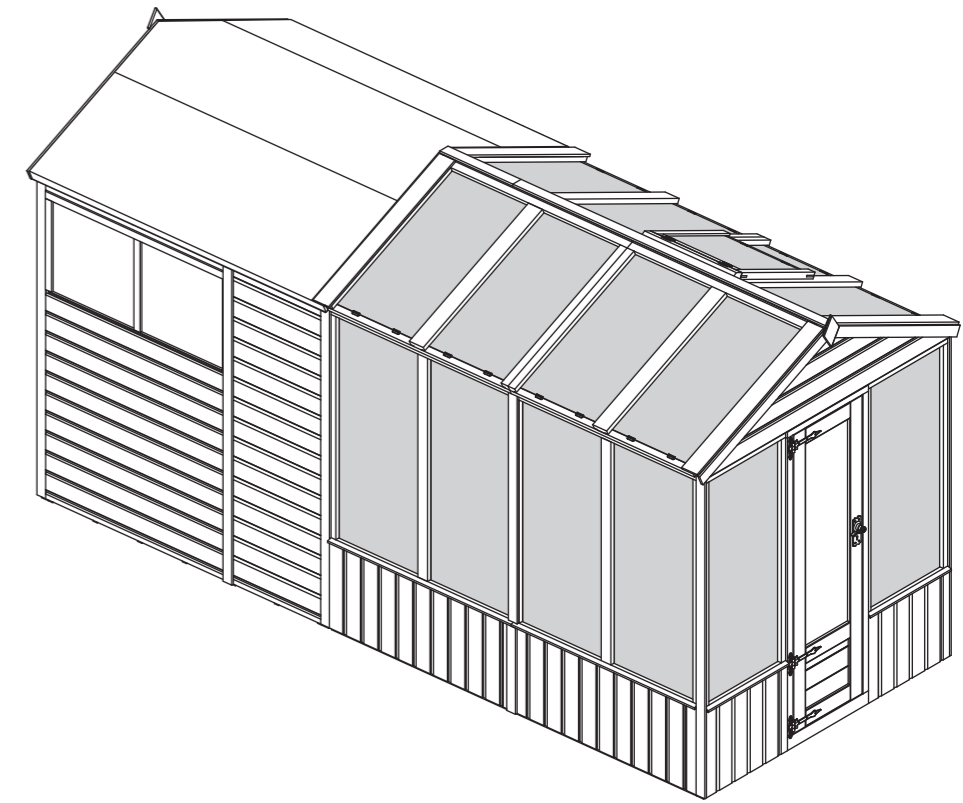

LEAVE US A REVIEW...



Want to share your experience with us?
Leave us a review on Feefo, TrustPilot or Google.

Your reviews help other people find and trust our business, as well as helping to play an important role in our growth and improvement!

TREATING YOUR GARDEN BUILDING

Preservation of wood that's outdoors is vital. A little early care will help protect your garden building, improve its appearance and ensure maximum longevity. Insects, moisture, salt, and changing weather can have dramatic effects on the stability and appearance of your garden building. Once your building is installed, you've checked it over and you're happy with it, you can take a few basic precautions to prepare it for the elements. Treating your garden building helps prevent decay and, by repelling water, discourages the growth of moulds and fungi that could jeopardise the structural integrity of the wood.

Dip Treated buildings - Require a preservative treatment to protect against rot and decay and a waterproof treatment to prevent water ingress
Pressure Treated buildings - Require a waterproof treatment to prevent water ingress
Log Cabins/Insulated Garden Rooms - Are supplied untreated and require a preservative and waterproofing treatment.



ANY QUESTIONS?
Scan the QR code to contact us via our customer portal.

To apply a preservative and water proofing treatment (pressure treated products do not require a preserver), follow the manufacturer's instructions but in principle, stick to the following steps:

- ✓ Weather permitting, ensure to treat your garden building within 14 days of installation.
- ✓ Wear latex or rubber gloves, eye protection and (if spraying) a mask.
- ✓ Prepare the wood, by sanding down any ridges or inconsistencies in the wood, smoothing out knots and end-cuts.
- ✓ Choose a dry day to treat your garden building. If you're spraying rather than brushing paint on, avoid a windy day.
- ✓ Be sure you can safely reach all the sections you need to paint - and if you need a ladder, make sure it's safely positioned before climbing. Lay dust sheets around to avoid paint splatters on your base or surrounding plants.
- ✓ Tape around windowpanes to avoid smears when you're painting the frames.
- ✓ Keep pets and small children out of the way. The last thing you want is to have fur on your garden building paint, or little painted footprints all over your garden and home.
- ✓ Fill any gaps in the building's body with caulk or wood filler to prevent water and draughts getting in. Silicone based caulk is flexible and will move with the timber when temperature and humidity change. Allow to dry completely before treating. A handy tip for finding gaps is to go into your garden building and look for light leaking through joins and frames. If light gets in, then so will water.
- ✓ Liberally apply at least two coats of the treatment products with a brush or spray, taking care to allow the first coat to completely dry before applying the second.
- ✓ Make sure the solution permeates the whole of the surface area, especially around natural cracks, end cuts and nail/screw holes.



APPLY WOOD TREATMENT
IMMEDIATELY
AFTER ASSEMBLY



1 Perimeter

Check around the perimeter of your product to ensure there are not trees or plants that are in contact with or overhanging the building. This can affect airflow and overhanging trees, or branches can damage the roof, it is advised to keep plants at a distance.

2 Repair

Inspect the interior and exterior of the product to look for splits, cracks, and holes. Although this is a natural occurrence it can be prevented. A wood filler can be used to close the splits, cracks, and holes.

3 Roof

Check your roof regularly for tears, splits, damaged wood and fallen debris. If you notice any of this immediate repair is critical.

4 Doors & Windows

Expansion and contraction can cause doors and windows to stick or become difficult to open. Small adjustments to the hinge position can be made to the doors and windows to allow free movement.

5 Oil

Hinges can seize up over time, apply lubricant to the hinges and locks annually.

6 Screws & Bolts

It is advised to check all screws and bolts and tighten any loose you might find. For log cabins specifically the storm braces will require loosening. During humidity and temperature changes (seasons) to allow expansion and contraction to prevent gaping, twisting, popping, and warping.

7 Wash

At least once a year, give the outside of you building a good wash, to remove cobwebs, leaves, or any other dirt that may accumulate on the exterior.

8 Airing

Airing your product regularly prevents the build up of condensation which can cause the timber to warp, bow, boards to pop, distortion, rot and mould. Condensation can build up over time or daily, it is caused by a rise and fall in temperature.

Excessive moisture levels within your building can cause water to collect on the roofs, walls and floors internally. Leaving doors and windows open regularly can help combat the natural moisture build up.

9 Clean & Tidy

It is good practice to clean the inside and outside of your product regularly. Clear out the contents, sweep the floor, remove dirt and cobwebs. Check for areas of damp and investigate the cause to remove and prevent future occurrences. Check the ground around your product for build up of debris such as leaves, remove and ensure there is clear ventilation underneath the floor.

All our garden buildings have been designed and manufactured with care and attention to be the perfect addition to your outdoor space. To ensure you do get the best out of your new garden building and to increase the longevity we advise that you follow the product instructions and our manufacturer's recommendations as detailed below. Thank you for choosing a Mercia Garden product!

1 Choosing the most suitable location for your garden building...

A minimum of 60cm should be left around the perimeter of your garden building to allow access for maintenance, annual treatment and to allow air flow around the building.

Where possible you should avoid placing your garden building underneath large trees to prevent the tree causing damage to the building.

2 Preparing the base for your garden building...

All our buildings must be built on a firm, level base to ensure the longevity of the building and prevent the wood from distorting. We recommend either concrete, concrete slabs or a wooden base, such as our 'Portabase'.

The base should be slightly smaller than the external measurement of the building, i.e. the cladding should overlap the base, creating a run off for water and preventing water from pooling underneath the building.

We also recommend that the floor of the garden building is a minimum of 25mm above the surrounding ground level to avoid flooding.

3 After installation...

Once your garden building has been installed, it will need to be treated within 14 days (weather permitting) and annually to prevent the timber from deteriorating and to waterproof it. This is required to maintain the anti-rot guarantee.

Dip Treated buildings - Require a preservative treatment to protect against rot and decay and a waterproof treatment to prevent water ingress.

We also recommend using a silicon sealant around the glazing on the inside and outside of the windows and roofs as soon as possible after assembly and treatment to fully seal the windows.

Roofing felt/covering should be checked annually and replaced or fixed accordingly.

4 General maintenance and wood characteristics

As wood is a natural material it may be affected by the following:

Shrinkage and warping - The timber used in the construction of your garden building will have retained some of its natural moisture content. The moisture content of the timber will vary, depending upon prevailing environmental conditions, which will result in the components either naturally expanding or contracting. As the components dry out, shrinkage may occur. A good waterproofing treatment from the start is the best protection to minimise the effect of moisture loss/intake.

In extended periods of very warm weather getting some moisture to the building will help the overall balance. You can do this by spraying it down lightly with a garden hose. In contrast, after snow fall try to remove the snow as best as possible from the roof to prevent moisture intake and to remove the extra weight.

Top tip - using a garden brush will help you to reach the highest part of the building to remove snow and any debris left from bad weather.

Damp and mould - During the winter months, cold and damp conditions can result in an increased amount of moisture within your garden building, especially when used infrequently. Condensation can form on the timber and other items stored within your garden building. If left this moisture is likely to cause mould and mildew.

To prevent the build-up of moisture, we recommend leaving the door or windows of your building open from time to time, to allow the fresh air to circulate. We also advise against storing wet or damp items in your garden building as this will also increase the level of moisture in the building. If mould or mildew does start to form within your building we recommend using an anti-mould cleaner to remove it and to prevent it spreading, which if left untreated could permanently damage your garden building.

Splits, cracks and knots - You may notice small splits and cracks in some components or holes may appear where knots shrink and fall out. This will not affect the structure of your Garden building however, if you wish to fill them this can be easily done using any good quality wood filler.

Sap - is naturally occurring in wood and may appear in some boards of your garden building. If you wish to remove the sap, we advise waiting until it is dry and then using a sharp knife to carefully remove it. If the removal of the sap causes a hole in the timber, we recommend using a good quality wood filler to fill it.

For more handy hints and tips on how to care and maintain your garden building please refer to the MGP Customer Portal at www.mgplogistics.co.uk

Any further questions?



Contact our Customer Service Team via the MGP Customer Portal at: www.mgplogistics.co.uk

1

Manufacturer's Warranty

All Mercia Garden Products are supplied with a 1 year warranty on all parts against manufacturing defects.

This warranty does not cover movement, warping or splitting of timber products over time.

This warranty will be voided if any of the following occur:

1. The building has been customised or modified/adapted in any way.
2. The person claiming is not the original purchaser of the building.
3. Any damage has been caused by or as a result of misuse.
4. The building has not been maintained and cared for in accordance to our advisories and manufacturer's recommendations.
5. The building has not been treated annually or as per the manufacturer's recommendations, please ensure receipts are kept to validate this claim.
6. The building has not been erected, fitted or installed as per the supplier instructions.
7. The building has not been erected on a suitable sized firm flat, solid level concrete/slab base or placed on pressure treated bearers.
8. The building is or has been placed with 2 feet (600mm) of any obstructions (walls, trees, plants, fences etc.) which can allow moisture to penetrate the timber.
9. The roofing felt has been incorrectly fitted or damaged, allowing water ingress, or has not been properly maintained.
10. Any windows and joints have not been sealed, inside and out, with silicone or other watertight sealant.
11. Any timber has been cut, pierced or drilled without subsequent application of approved cut-end treatment.

REGISTER FOR YOUR
10 YEAR
ANTI-ROT
GUARANTEE TODAY



www.mgplogistics.co.uk

2

Anti-rot Guarantee

Mercia Garden Products offer a 10 year anti-rot guarantee on all dip treated (a preparatory treatment) and 15 years on all pressure treated products. This guarantee covers solid timber against rot, decay, blue stain and insect attacks.

To validate the guarantee, the building must be treated (as detailed within manufacturer's recommendations) within 14 days (weather permitting) of assembly and annually thereafter.

This guarantee does not cover movement, warping or splitting of timber products over time.

This guarantee will be voided if any of the following occur:

1. The building has been customised or modified/adapted in any way.
2. The person claiming is not the original purchaser of the building.
3. Any damage is caused by or as a result of misuse.
4. The building has not been maintained and cared for in accordance to our advisories and manufacturer's recommendations.
5. The building has not been treated annually or as per the manufacturer's recommendations, please ensure receipts are kept to validate this claim.
6. The building has not been erected, fitted or installed as per the supplier instructions.
7. The building has not been erected on a suitable sized firm flat, solid level concrete/slab base or placed on pressure treated bearers.
8. The building is or has been placed with 600mm of any obstructions (walls, trees, plants, fences etc.) which can allow moisture to penetrate the timber.
9. The roofing felt has been incorrectly fitted or damaged allowing water ingress, or has not been properly maintained.
10. Any windows and joints have not been sealed, inside and out, with silicone or other watertight sealant.
11. Any timber has been cut, pierced or drilled without subsequent application of approved cut-end treatment.