

02DTTWR0605-V1-PEFC  
6X5 PLAYHOUSE TOWER.

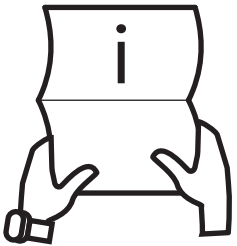

**BEFORE YOU START PLEASE READ THE INSTRUCTIONS CAREFULLY**

- Check the pack and make sure you have all the items listed in the parts list provided.
- When you are ready to start, make sure you have the right tools at hand (not supplied - see the equipment list on next page).
- Ensure there is plenty of space and a clean dry area for assembly.
- Ensure you have enough time to build the product to ensure the building is water tight.

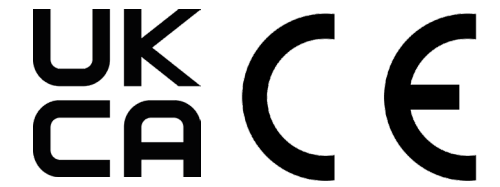
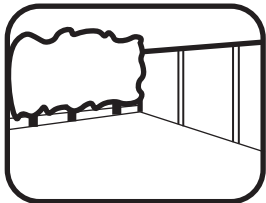

**LOCATION FOR YOUR PLAYHOUSE**

When thinking about where the building and where the base is going to be constructed: Ensure that there will be access to all sides for maintenance work and annual treatment.

We recommend a **minimum space of 2m around a playhouse**, away from any structure or obstructions such as fences, garages, houses, overhanging branches, washing lines or electrical wires.

It is recommended that the position of the Playhouse is **not in direct sunlight**.

**Activity toys such as swings and slides for towers shall not be installed over concrete, asphalt or any hard surface.**

Whilst all products manufactured are made to the highest standards of safety and in the case of childrens products independently tested to EN71, we cannot accept responsibility for your safety whilst erecting this product.

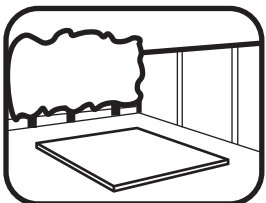

**BUILDING A BASE**

When thinking about where the building and where the base is going to be constructed: Ensure that there will be access to all sides for maintenance work and annual treatment.

Ensure the base is level and is built on firm ground, to prevent movement. Refer to the contents page for the base dimensions. The base should be slightly smaller than the external measurement of the building, i.e. The cladding should overlap the base, creating a run off for water. It is also recommended that the floor be at least 25mm above the surrounding ground level to avoid flooding.

**TYPES OF BASE**

- Concrete 75mm laid on top of 75mm hard-core.
- Slabs laid on 50mm of sharp sand.
- Wooden base - Levelled / on posts / ground screws.

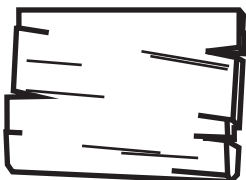

**TIMBER**

As with all natural materials, timber can be affected during various weather conditions. For the duration of heavy or extended periods of rain, swelling of the wood panels may occur. Warping of the wood may also occur during excessive dry spells due to an interior moisture loss. Unfortunately, these processes cannot be avoided but can be helped. It is suggested that the outdoor building is sprayed with water during extended periods of warm sunshine and sheltered as much as possible during rain or snow.



**WARNING:** Only for domestic use  
Not suitable for children under 36 months due to small gaps and danger of falling from heights.  
To be used under direct supervision of an adult

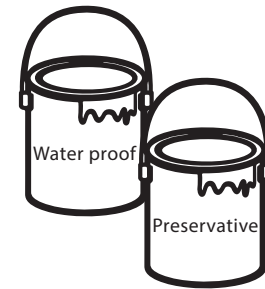

**TREATMENT**

Once your garden building has been installed it will need to be treated within 14 days (weather permitting) and annually to prevent the timber from deteriorating and to waterproof it. This is required to maintain the anti-rot guarantee.

- Dip Treated buildings - Require a preservative treatment to protect against rot and decay and a waterproof treatment to prevent water ingress
- Pressure Treated buildings - Require a waterproof treatment to prevent water ingress
- Log Cabins/Insulated Garden Rooms - Are supplied untreated and require a preservative and waterproofing treatment.

**\*\*Protim Aquatan T5 (621)\*\***

Your building has been dip treated with Aquatan.

Aquatan is a water-based concentrate which is diluted with water, the building has been treated by the correct application of Aquatan solution and then allowed to dry.

Aquatan is a decorative finish to colour the wood, which is applied industrially to timber fence panels and garden buildings.

Aquatan undiluted contains: boric acid, sodium hydroxide 32% solution, aqueous mixture of sodium dioctyl sulphosuccinat and alcohols: 2, 4, 6-trichlorophenol.



**WARNING**

- ONLY SUITABLE FOR DOMESTIC USE.
- TO BE USED UNDER DIRECT SUPERVISION OF AN ADULT.
- THIS PRODUCT SHOULD NOT BE MODIFIED IN ANY WAY. ANY MODIFICATIONS SHOULD BE DETERMINED BY THE MANUFACTURER AND CARRIED OUT ACCORDING TO THE INSTRUCTIONS.
- DO NOT ALLOW YOUR CHILD TO PLAY WITH ANY COMPONENT PARTS PRIOR TO ASSEMBLY.
- MAX AGE OF 14 YEARS.
- THIS TOY IS FOR OUTDOOR USE ONLY.
- USE A WATER BASED TREATMENT THAT IS EN71 TESTED.

Look for the symbols and follow the safety guidelines below.



Ensure screw heads are sub flush and sand down any splinters created.



Ensure the screws are fixed squarely and do not protrude.



50kg per user



12mm gap surrounding the door.



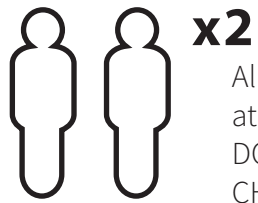

x2

All buildings should be erected by at least two adults.

DO NOT ALLOW CHILDREN TO ASSIST.

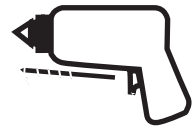

2mm Drill bit

For ease of assembly, you **MUST** pilot drill all screw holes and ensure all screw heads are countersunk.



For ease of assembly, you will need a tape measure to check dimensions of components and fixings.

Screws & Nails

Bolts

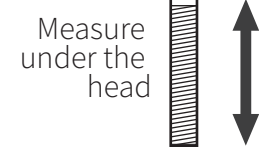

Winter = High Moisture = Expansion  
Summer = Low Moisture = Contraction



**CAUTION**

Wood is a natural product and can change post manufacture. So despite every effort being made to ensure the material used are cut and machined to a clean and smooth finish, care must be taken when handling the product and preparing for use by your child.

Any areas of concern, in the play areas, can be rubbed over with sandpaper to achieve a smoother finish. Alternatively, call the customer service department who will be happy to arrange replacement panels/parts.

**NOTES**

REGISTER FOR YOUR  
**10 YEAR  
ANTI-ROT  
GUARANTEE TODAY**

In all instances for assistance with your product or to register your anti rot guarantee, please contact us via our customer portal

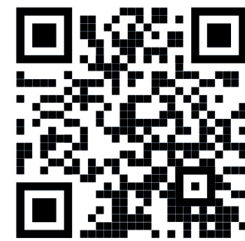

[www.mgplogistics.co.uk](http://www.mgplogistics.co.uk)

Mercia Garden Products Limited, Sutton On Trent, Newark, Nottinghamshire, NG23 6QN

**TO DO LIST**

- Find a suitable location to build *(see front cover for further information).*
- Build a base *(see front cover for further information).*
- Check the base is flat, level, clear of debris and has 600mm clearance on all sides.
- Check you have the required equipment / tools.
- Check you have all the product items listed *(if you have missing or damaged parts please scan the QR code to visit our online customer portal).*
- Install the product as per the step by step instructions within this pack.
- Prepare the product ready for treatment (this may include sanding).
- Apply a preserving and a waterproofing treatment within 14 days *(weather permitting)* of installation.
- Register for your anti-rot guarantee *(scan the QR below).*
- Tidy the build area and dispose of any remaining parts responsibly.
- Maintain your building *(see the manufacturers recommendations at the back of this pack).*

**EQUIPMENT LIST**

- Hammer
- Flat Head Screwdriver
- Drill
- Drill Bit Set
- Phillips and Slotted Bit Sets
- Tape Measure
- Hand Saw
- Spirit Level
- Ladders/Steps
- Stanley Knife/Cutting Tool
- Sand Paper
- Gloves
- Silicone (For Windows Only)
- Wood Filler (Optional)
- Timber Preservative Treatment
- Timber Water Proofing Treatment
- Treatment Mixing Stick
- Paint Brush/Sprayer/Roller

**NEED EXTRA SUPPORT**

If you are unsure that your base preparation will be suitable, please contact us via our customer portal to discuss this further.

Alternatively, you can visit our website or MGP Logistics Online Portal for some further sheducation.

**Website:**

<https://www.merciagardenproducts.co.uk/sheducation>

**MGP Logistics Online Portal:**

<https://www.mgplogistics.co.uk/>

Here you will find plenty of useful information that'll help with most pre-installation and maintenance queries.



**ANY QUESTIONS?**

Scan the QR code to contact us via our customer portal.

## ACCESSING VIDEO GUIDES...

Some steps within this set of instructions come with an added video guide for your convenience. These can be accessed via the QR code and used to aid you in constructing that step. See below for how to use.

You can also find all the videos on our youtube channel:  
<https://www.youtube.com/@merciagardenproducts8716/videos>

### 1. Find the QR code within the instruction step...

#### Step.....

Parts Needed- No. QTY 1  
No. QTY 1  
No. QTY 1

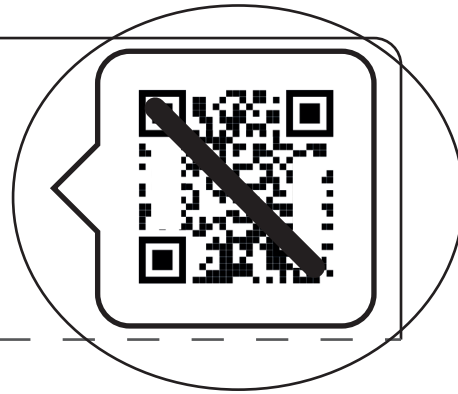

Within the instruction step, there will be an icon in the top right that has a QR code in. This is where the video can be accessed from.

*Please note: not every step has a video guide.*

### 2. Open camera app...

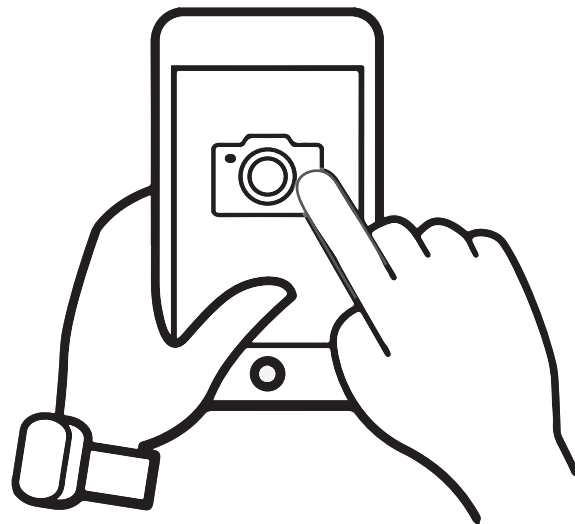

On your personal smart device (phone, tablet etc), open your camera app or QR code scanner app.

## ACCESSING VIDEO GUIDES...

### 3. Scan QR code...



To scan the QR code, hold the camera over the QR code so that it can be seen on the screen. Once the QR code has been registered, follow the prompts on your device to open the video. (This will vary depending on your device.)

*Please note: Ensure to use the back camera of your smart device as this will scan the QR code more accurately.*

### 4. Watch the video...



The video guide will now be displayed on your smart device.

**Disclaimer:** The garden building constructed in the video guides may be constructed differently to your building. Please ensure to read your instructions carefully to avoid error.

**Playhouse Options:**

Take a look at the different playhouse options below.  
 These refer to the instruction leaflets required to build each option.

Model	Build Instructions Required
<b>4x4 Playhouse With Tower</b> <i>SI-002-001-0043</i>	02DTSHAX0404BDH1W-V2-PEFC ( <i>Playhouse</i> ) 02DTTWR0605-V1-PEFC ( <i>Tower</i> )
<b>4x4 Playhouse With Tower &amp; Slide</b> <i>SI-002-001-0040</i>	02DTSHAX0404BDH1W-V2-PEFC ( <i>Playhouse</i> ) 02DTTWRS0605-V1-PEFC ( <i>Tower With Slide</i> )
<b>4x4 Playhouse With Tower, Slide &amp; Swing</b> <i>SI-002-001-0100</i>	02DTSHAX0404BDH1W-V2-PEFC ( <i>Playhouse</i> ) 02DTTWRS0605-V1-PEFC ( <i>Tower With Slide</i> ) 02PATINCSWA-V1-PEFC ( <i>Swing Set</i> )

**4x4 Playhouse With Tower**

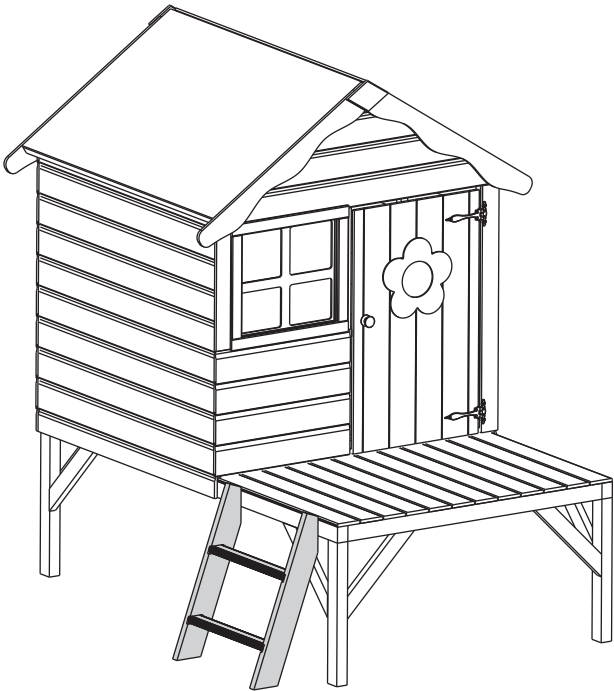

**4x4 Playhouse With Tower & Slide**

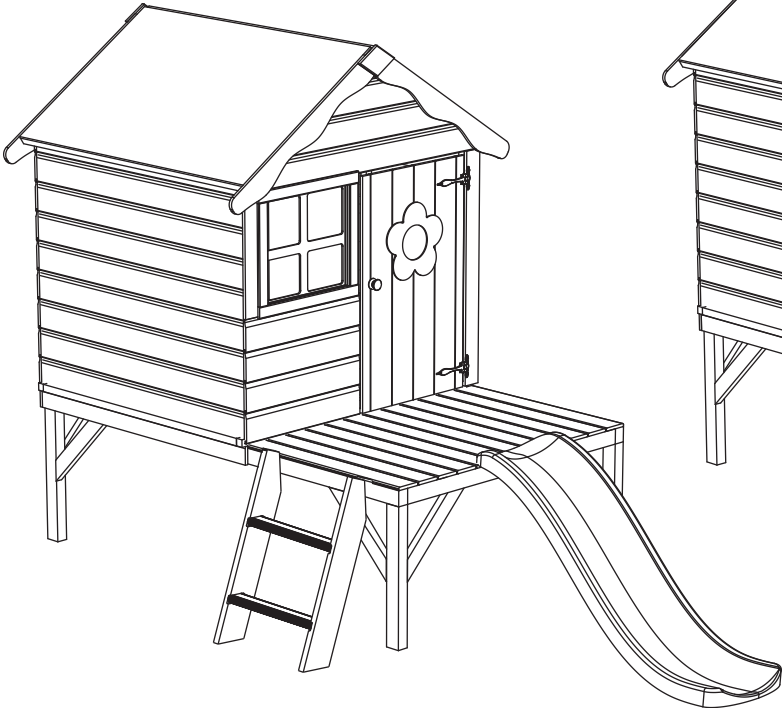

**4x4 Playhouse With Tower, Slide & Swing**

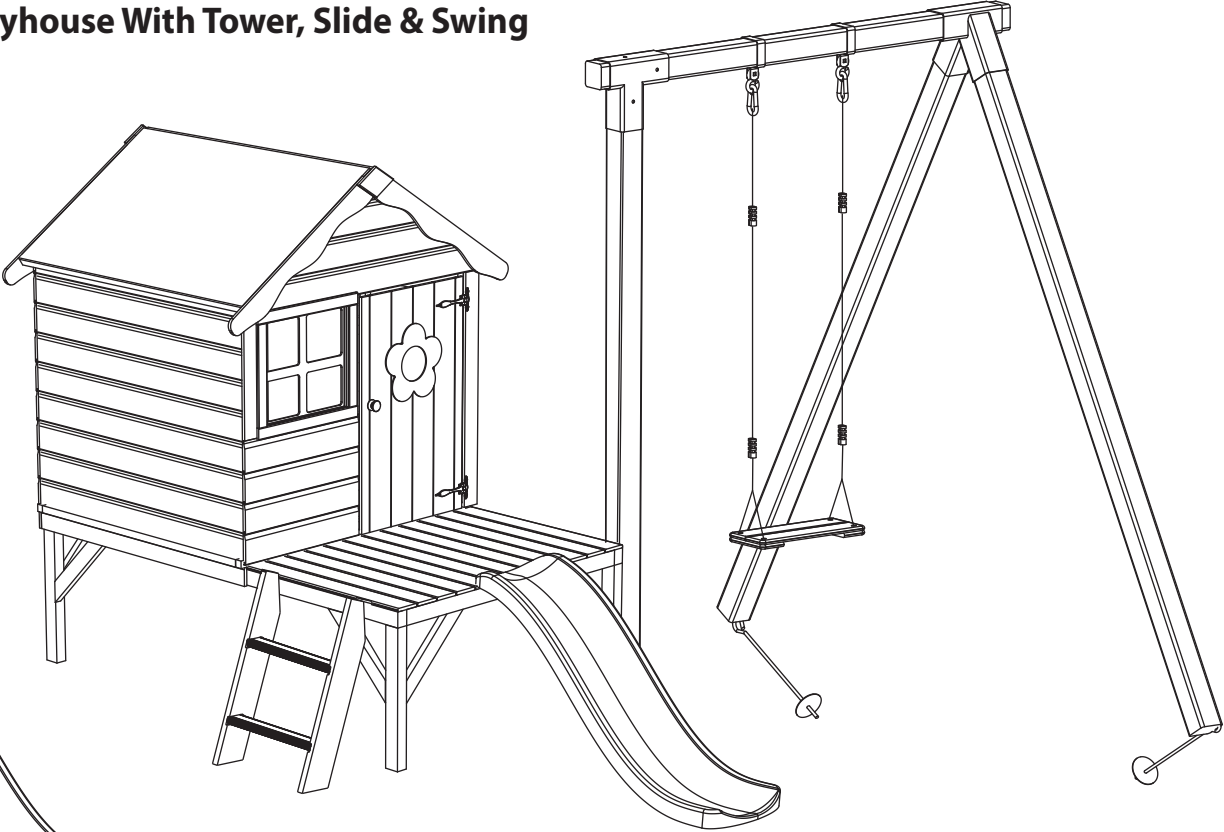

DO NOT ALLOW YOUR CHILD TO PLAY WITH ANY COMPONENT PARTS PRIOR TO ASSEMBLY.



**02DTTWR0605-V1-PEFC**

**Overall Dimensions:** Width = 1870mm  
**Base Dimensions:** Width = 1870mm  
 Depth = 1437mm  
 Height = 618mm

\* Measurements do not include slide & ladder \*

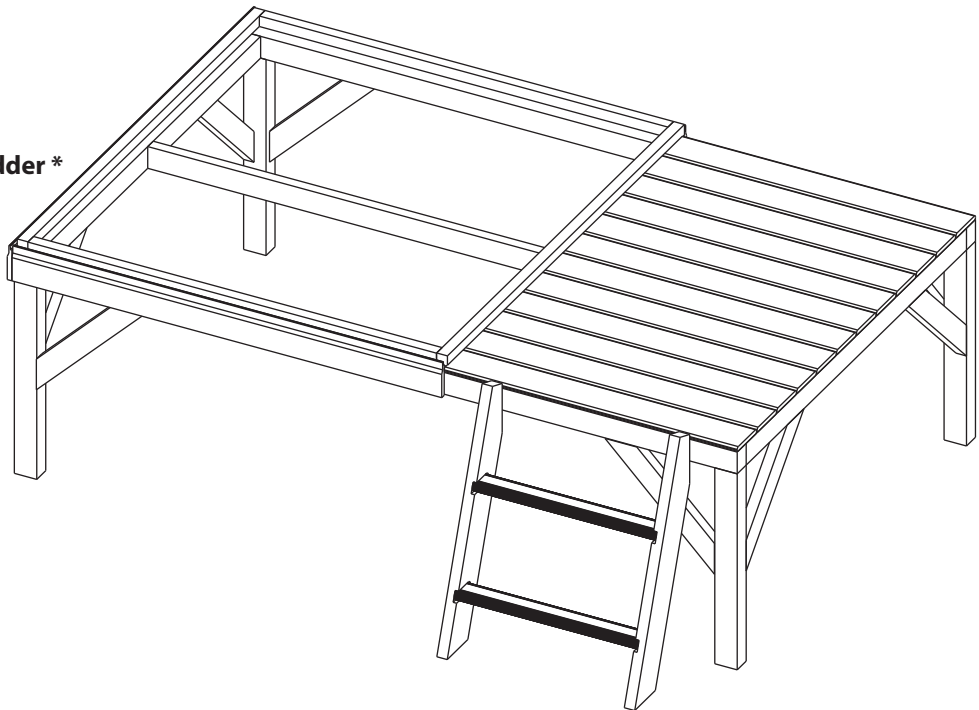

**Building Content:**

Tip: Labelling your parts, using a pencil and masking tape, may help you to identify them easier when you need them.



1

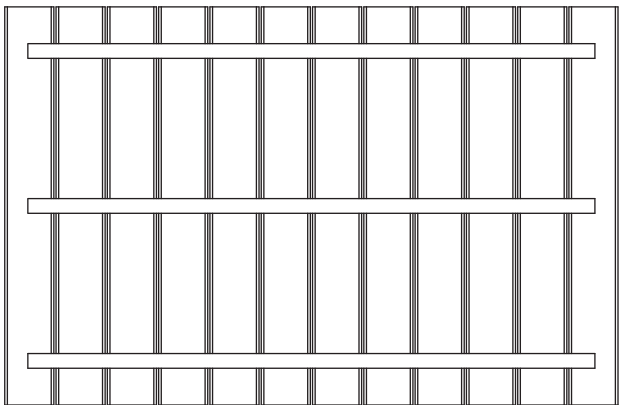

**Outer Floor QTY 1**  
 AI-S11STISF1168X758-V1



2

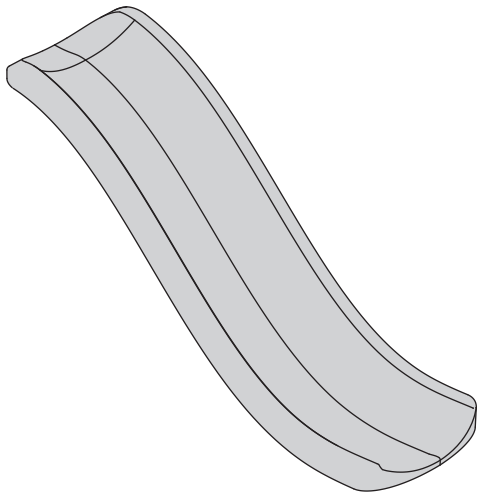

**Slide QTY 1**  
 PI-10-0005



3

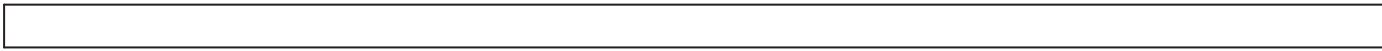

End View

**Framing - 44x58x1870mm QTY 2**  
 F4458-1870mm

4



End View

**Framing - 44x58x1080mm QTY 3**  
 F4458-1080mm

5

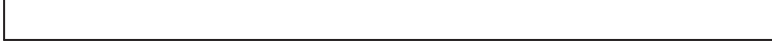

End View

**Framing - 44x58x1044mm QTY 1**  
 F4458-1044mm

6



End View

**Leg Post - 44x58x523mm QTY 4**  
 F4458-523mm

7

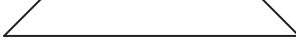

End View

**Leg Brace - 44x58x400mm QTY 8**  
 F4458-G-440mm ANGLED

8

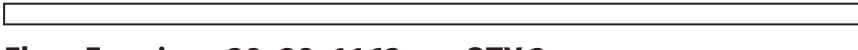

End View

**Floor Framing - 28x28x1162mm QTY 2**  
 FS2828-1162mm

9

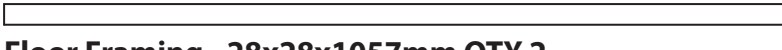

End View

**Floor Framing - 28x28x1057mm QTY 2**  
 FS2828-1057mm

10

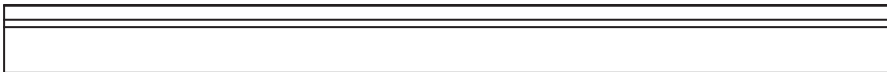

End View

**Shiplap Board - 12x92x1200mm QTY 1**  
 WBRT92-1200mm

11

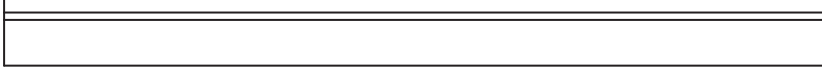

End View

**Shiplap Board - 12x92x1112mm QTY 2**  
 WBRT92-1112mm

12



End View

**Ladder Side Left - 476mm QTY 1**  
 PRO2795-476mm

13



End View

**Ladder Side Right - 650mm QTY 1**  
 PRO2795-650mm

14







End View

**Ladder Step - 27x58x476mm QTY 2**  
 PRO2758-476mm

DO NOT ALLOW YOUR CHILD TO PLAY WITH ANY COMPONENT PARTS PRIOR TO ASSEMBLY.

### Screw Pack

-  100mm Screw x 28
-  50mm Screw x 28
-  40mm Screw x 24
-  30mm Screw x 10

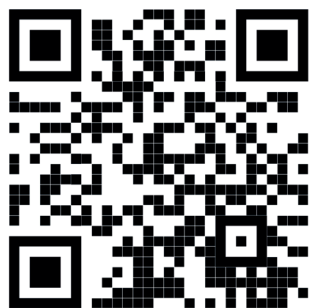

### Missing parts?

Scan the QR code to visit our customer portal where you can quickly raise any missing or damaged parts and get a replacement sent out ASAP.



### Pre Assembly

Before assembling remove the transportation blocks from the bottom of each panel.

Take care removing the blocks as to not damage the panels. Tap with a flat headed screwdriver and hammer.

Dispose of the blocks once removed.

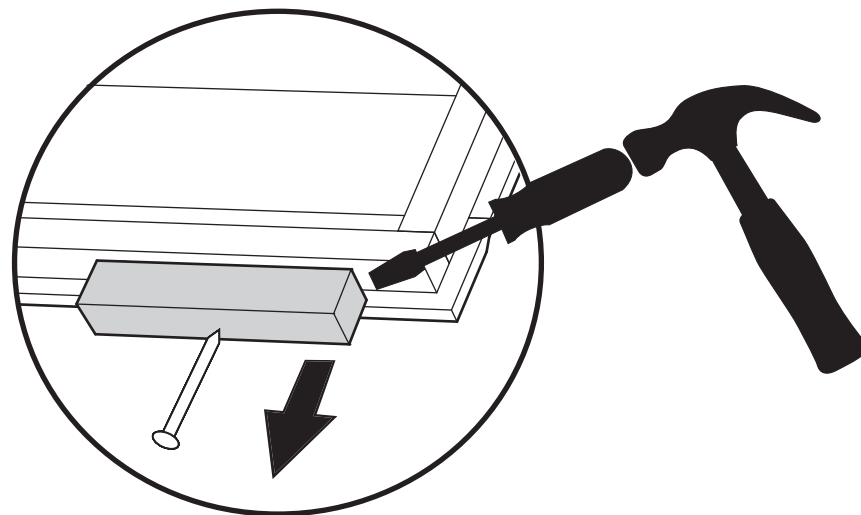

**Before assembly, please make sure you have a suitable base ready to install your building onto.**

### Step 1

Parts needed - **3** & **4**



Place the Framing (**No. 3**) and Framing (**No. 4**) as shown, ensuring the ends are flush.

Fix the framing together by screwing through the side of the framing to the end of the framing below using 1x100mm screw per end, as shown.

2x100mm screws

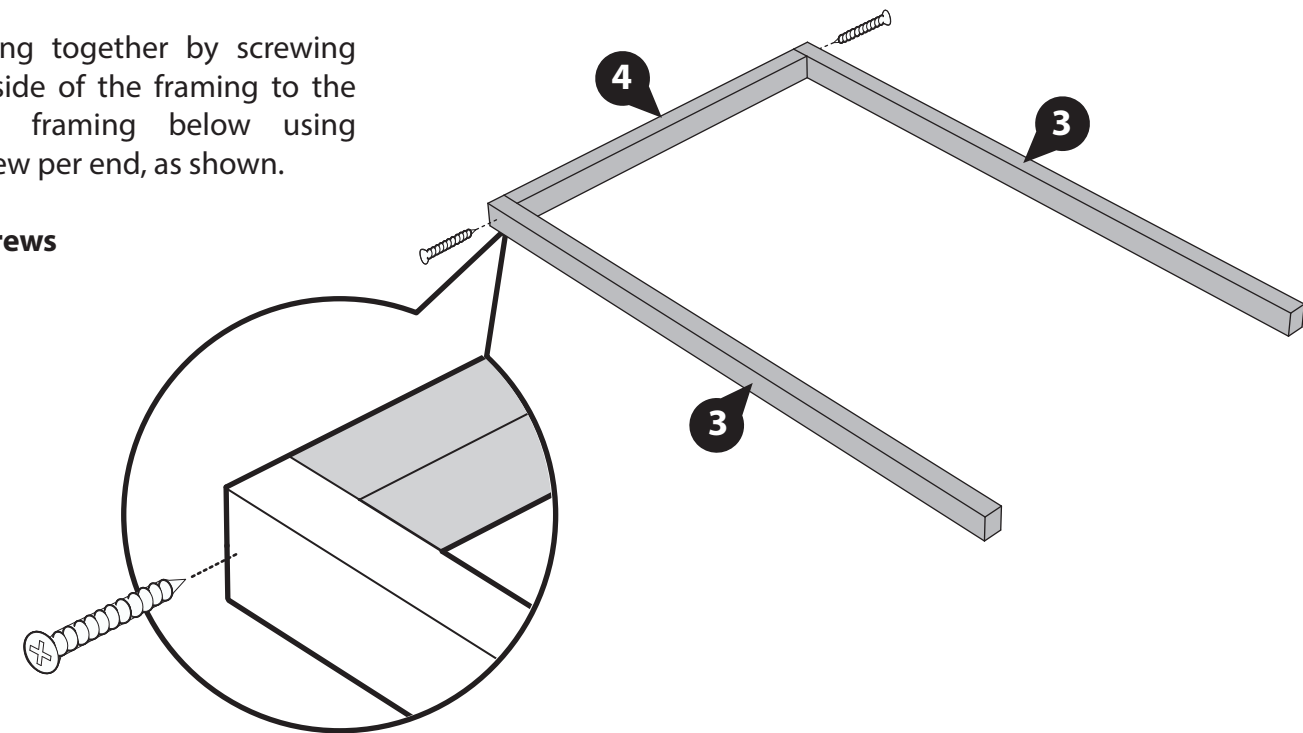

**Step 2**  
Parts needed - 4 & 5

Place the Framing (No. 4) and Framing (No. 5) inside the frame.

Make sure No. 5 is positioned in the centre and use it as a guide for positioning No. 4 in the middle.

Fix together as shown with 1x100mm screw per end.

6x100mm screws

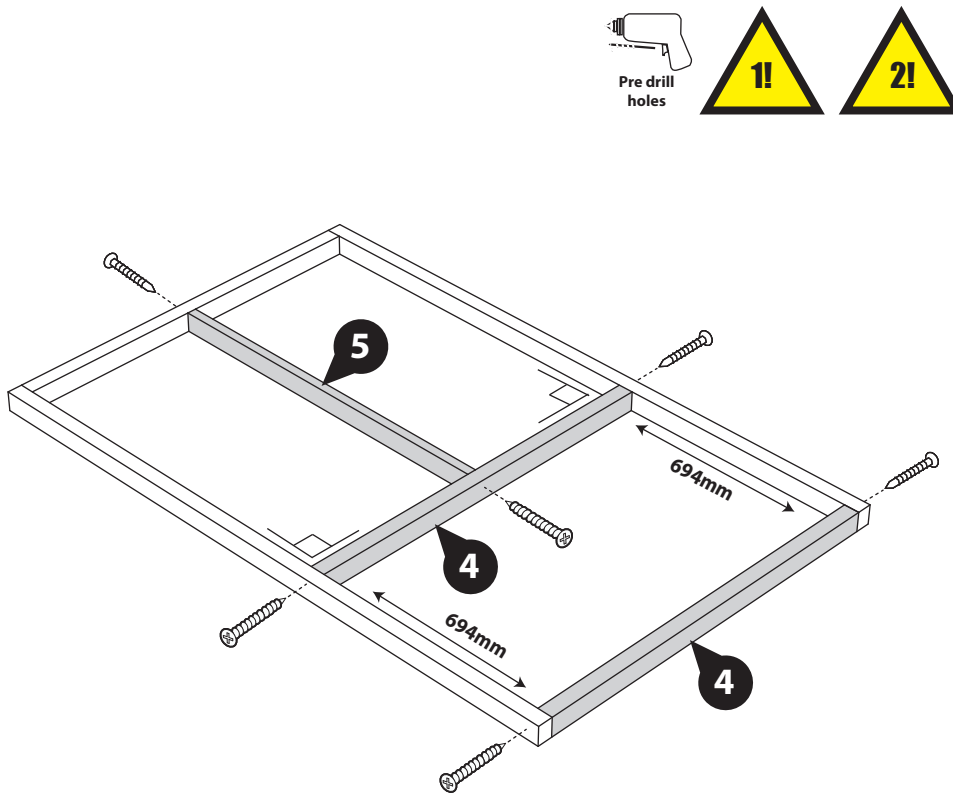

**Step 4**  
Parts needed - 7

Fix the Leg Braces (No. 7) to either side of each leg post by screwing through the framing into the leg brace, and up through the leg post into the leg brace, using 2x100mm screws per brace.

Ensure the framing is level so that the corners and legs are square and flush.

16x100mm screws

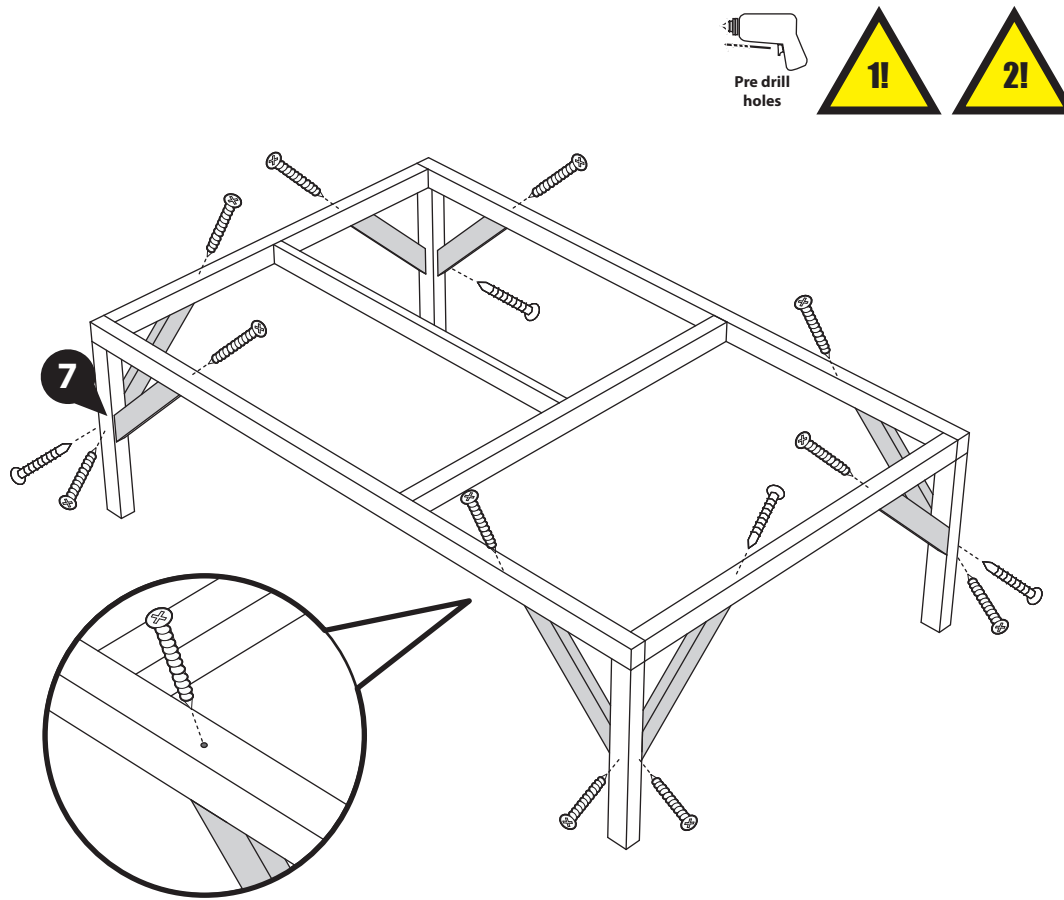

**Step 3**  
Parts needed - 6

Lift the assembled frame up and position the leg posts (No. 6) underneath as shown.

Fix the leg posts to the frame by screwing through the framing into the leg post, using 1x100mm screw per leg post.

4x100mm screws

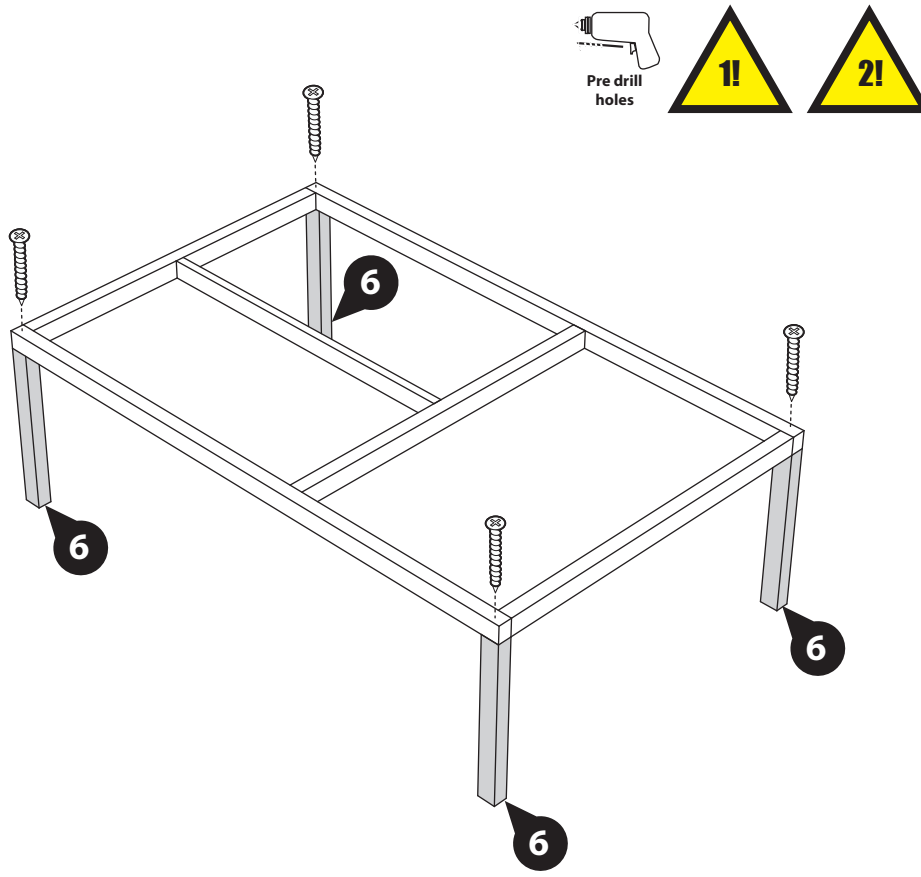

**Step 5**  
Parts needed - 1

Place the Outer Floor (No. 1) on top of the framing and make sure that the edge of the floor is flush with the end of the platform.

Fix into position by screwing through the floor into the framing below, using 10x40mm screws.

10x40mm screws

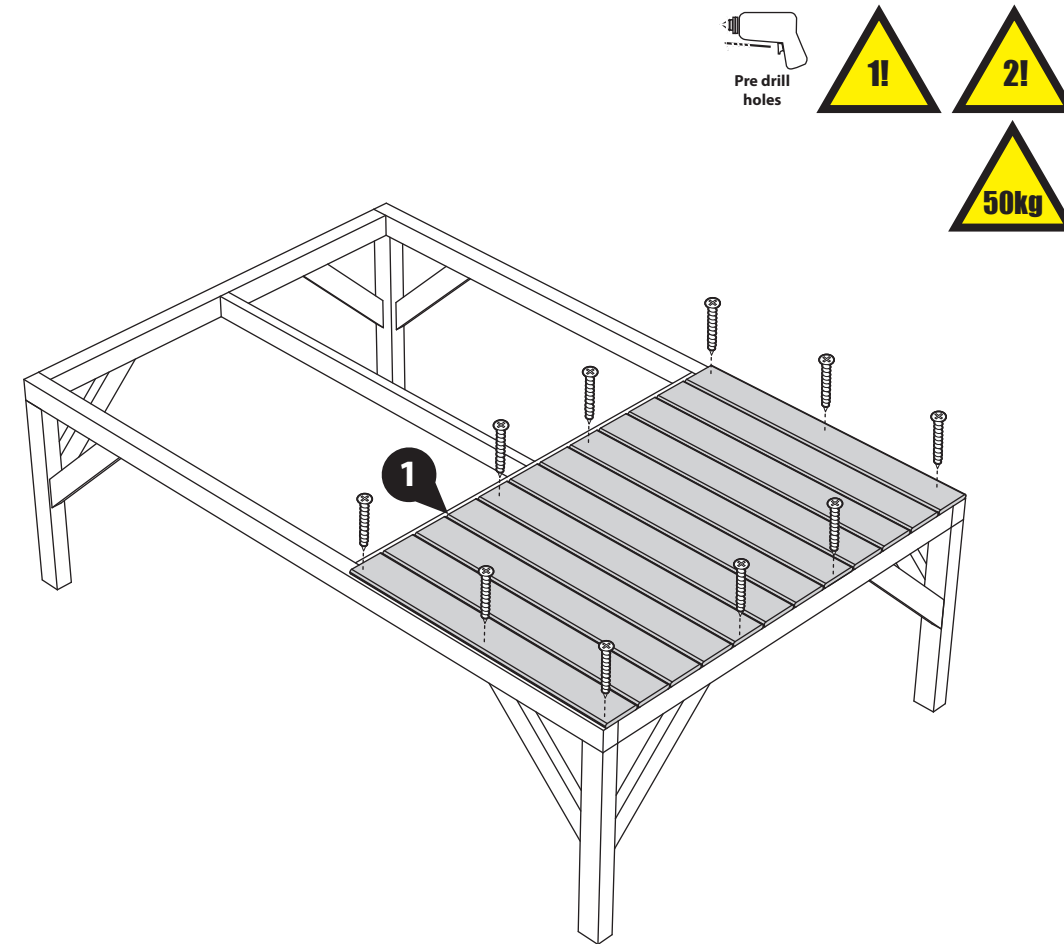

DO NOT ALLOW YOUR CHILD TO PLAY WITH ANY COMPONENT PARTS PRIOR TO ASSEMBLY.

**Step 6**  
Parts needed - Refer to playhouse

Take out the solid OSB floor sheet that is supplied with the playhouse.

Place the floor sheet on top of the framing platform and secure into position using the 10x30mm screws.

**10x30mm screws**

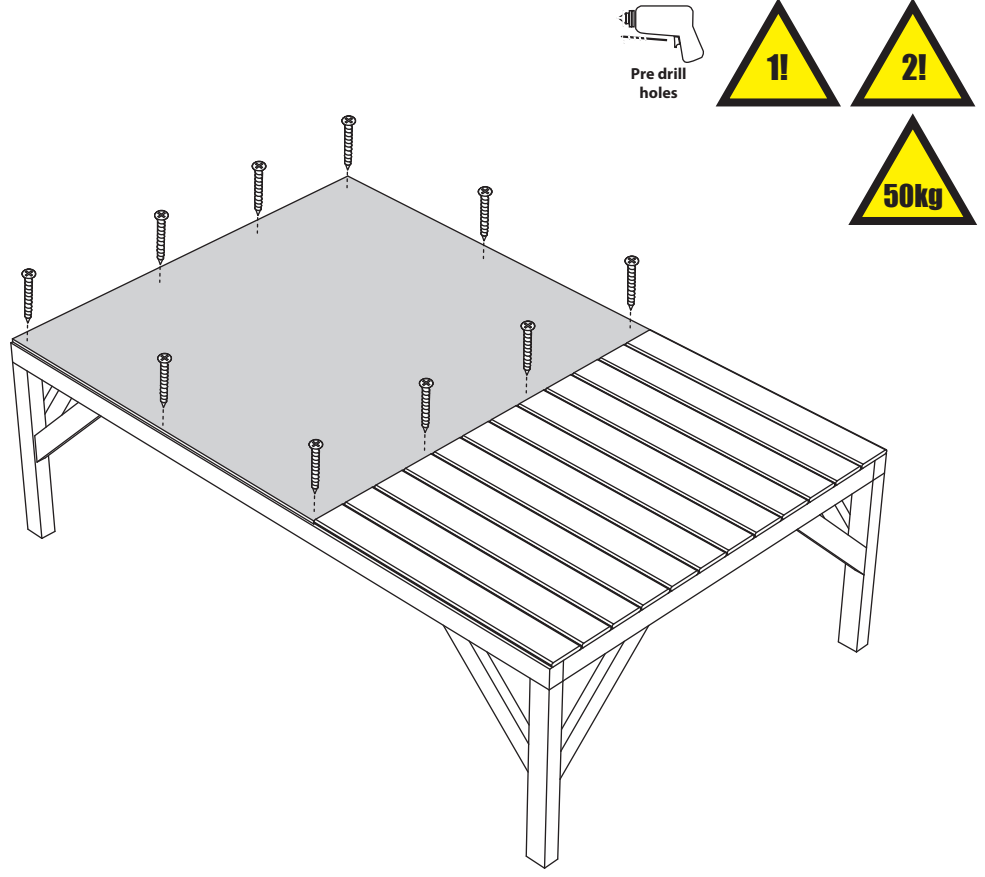

**Step 8**

The playhouse can now be assembled on top of the framing.

Follow the instructions provided with the playhouse to do this.

*\*Disregard the floor joists as these are not needed when fitting to the platform.*

Secure the playhouse to the framing with 8x50mm screws.

**8x50mm screws**

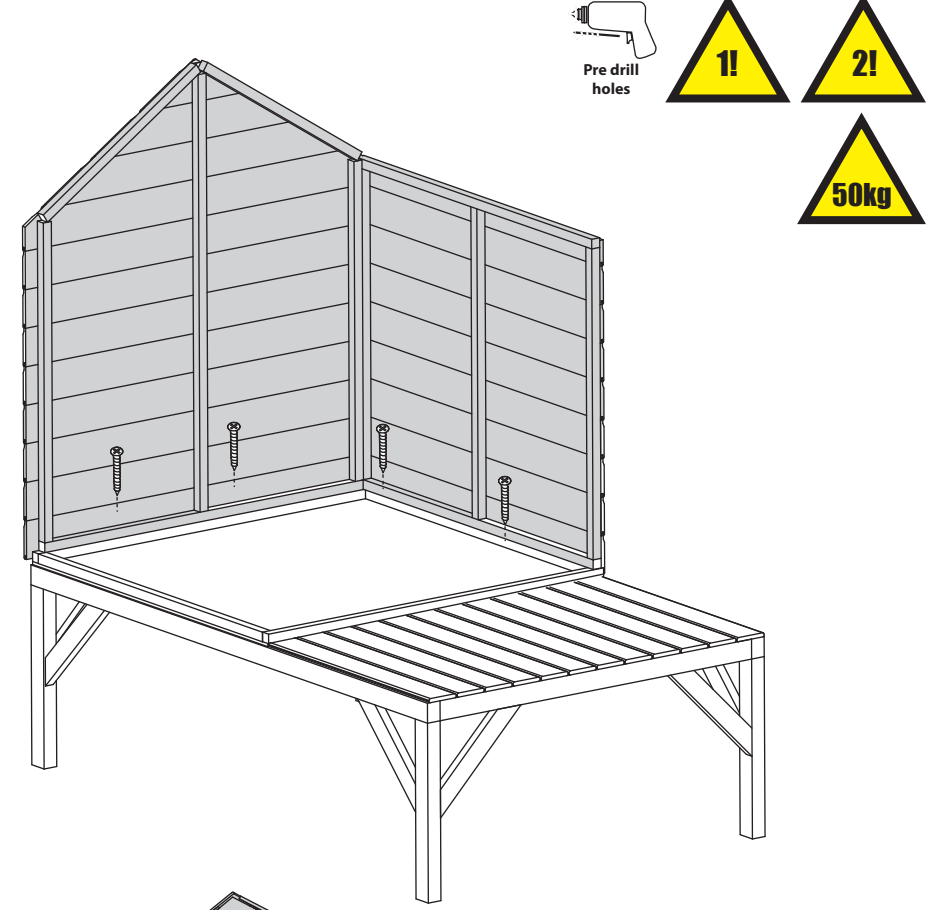

**Step 7**  
Parts needed - 8 & 9

Place the Floor Framing (No. 8 & 9) on top of the floor sheet and locate around the edge as shown, ensuring each piece is flush to the edge of the floor sheet.

Fix in place using 3x50mm screws per frame.

**12x50mm screws**

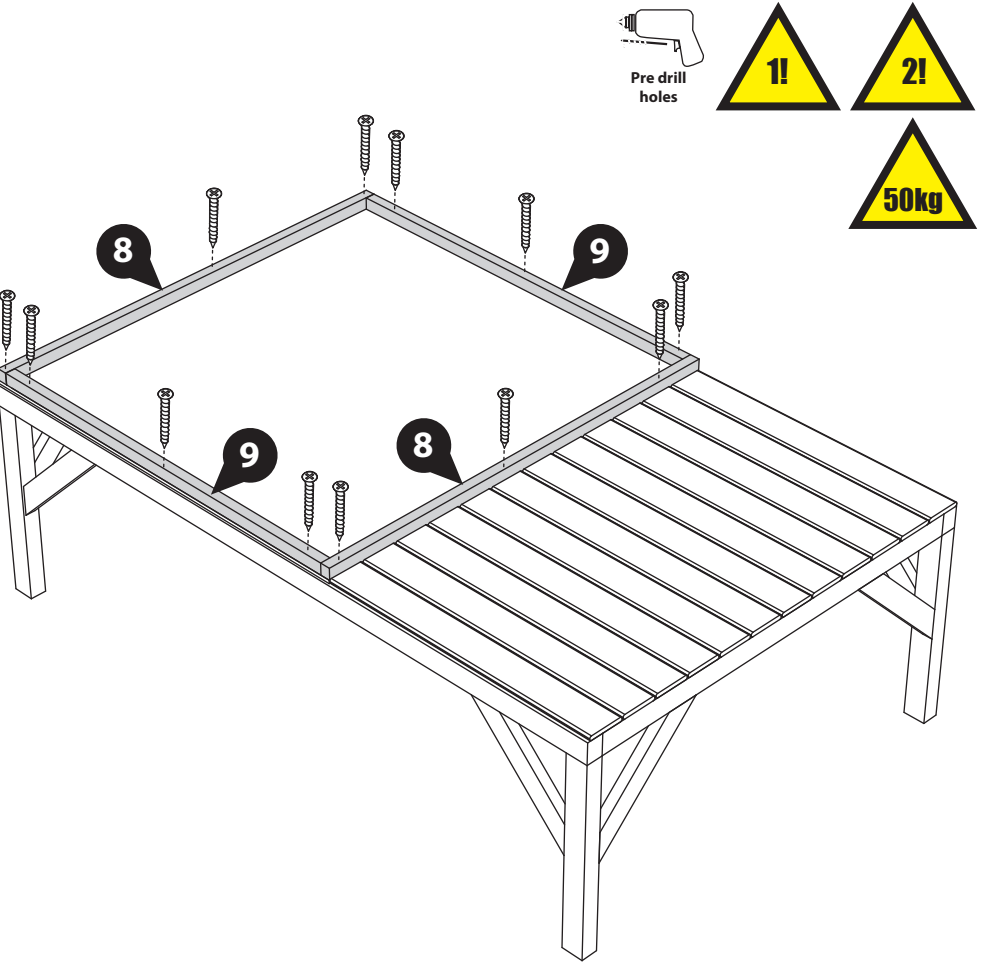

**\*\*Ensure to check the rigidity of the parts and tighten and adjust where necessary.**

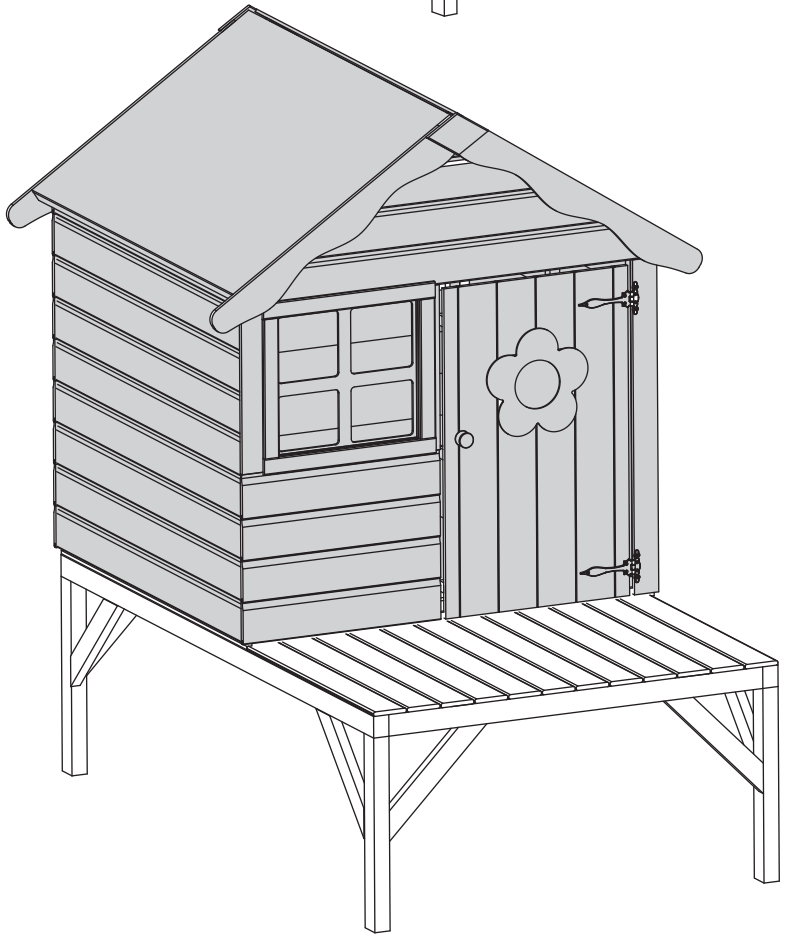

DO NOT ALLOW YOUR CHILD TO PLAY WITH ANY COMPONENT PARTS PRIOR TO ASSEMBLY.



**Step 9**  
Parts needed - **10 & 11**

Slot the Shiplap Boards (No. 10 & 11) into the bottom of the cladding around the sides.

Fix them into position by screwing through the face of the board into the framing below using 4x40mm screws per board.

12x40mm screws

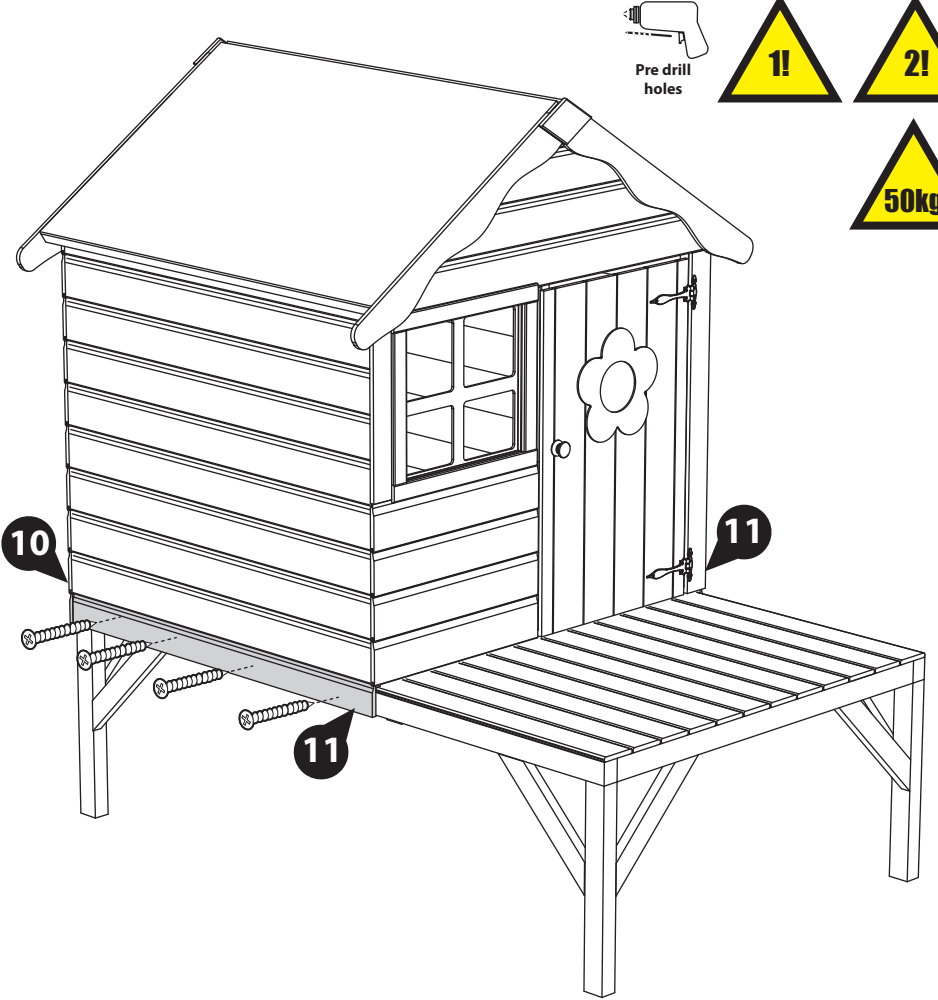

**Step 10**  
Parts needed - **12 & 13 & 14**

Slot the two Ladder Steps (No. 14) between the Ladder Side Left (No. 12) and the Ladder Side Right (No. 13).

Fix with 2x50mm screws per end, as shown.

8x50mm screws



\*\*Check for any post manufacture splits in the wood.

If present, do not use and contact the customer service team for replacement parts.\*\*

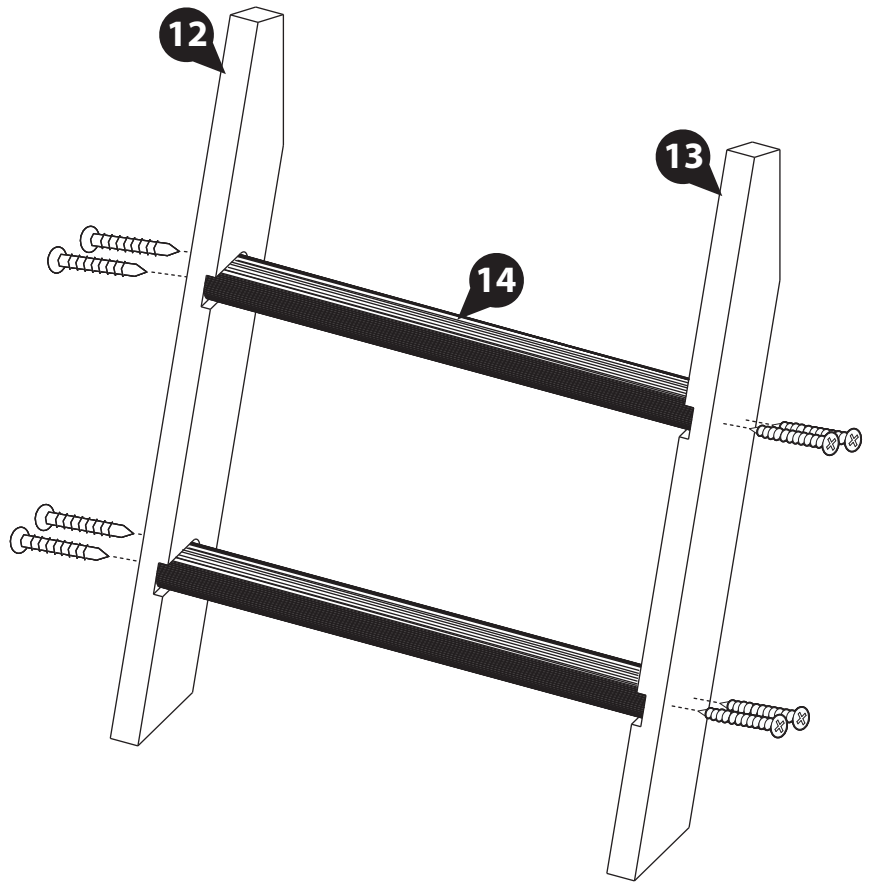

DO NOT ALLOW YOUR CHILD TO PLAY WITH ANY COMPONENT PARTS PRIOR TO ASSEMBLY.

**Step 11**  
**Parts needed - 2**

**a** Place the assembled ladder against the platform as shown. Fix into position using 2x100mm screws. **Ensure the top of the ladder is flush with the top of the platform.**

**b** Place the Slide (No. 2) into position as shown. Fix into place with 2x40mm screws.

The position of the ladder and slide can be reversed to create an alternative set up if desired.

**\*Do not place either the ladder or slide on the same side that the door opens as this creates a potential safety hazard.\***

2x 40mm screws  
2x100mm screws

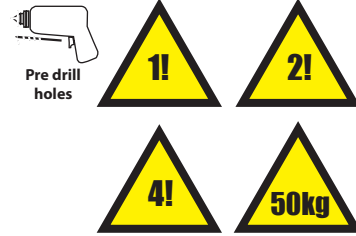
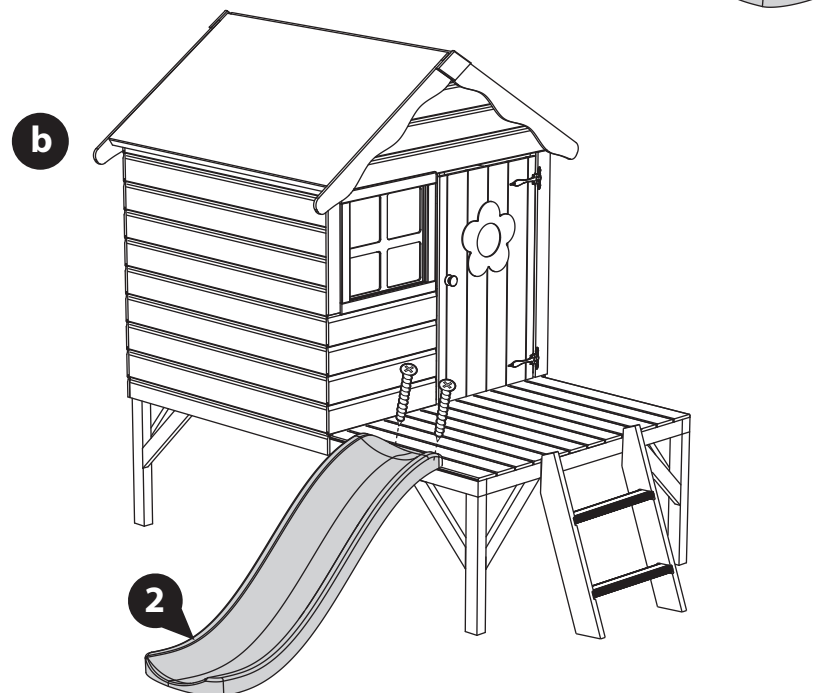
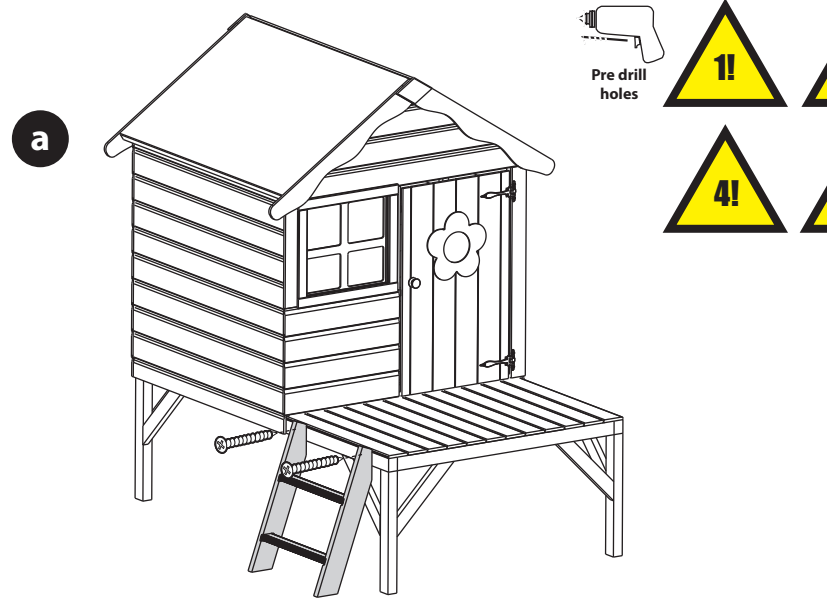
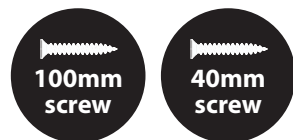

**Step 13**

Once constructed, apply a preserving treatment and a waterproofing treatment to your garden building as soon as possible. This will help to protect your building and prevent decay.

See page 11 for a full guide and instructions.

Once fully treated, score around the protective covers on the glazing and carefully peel the coverings back.

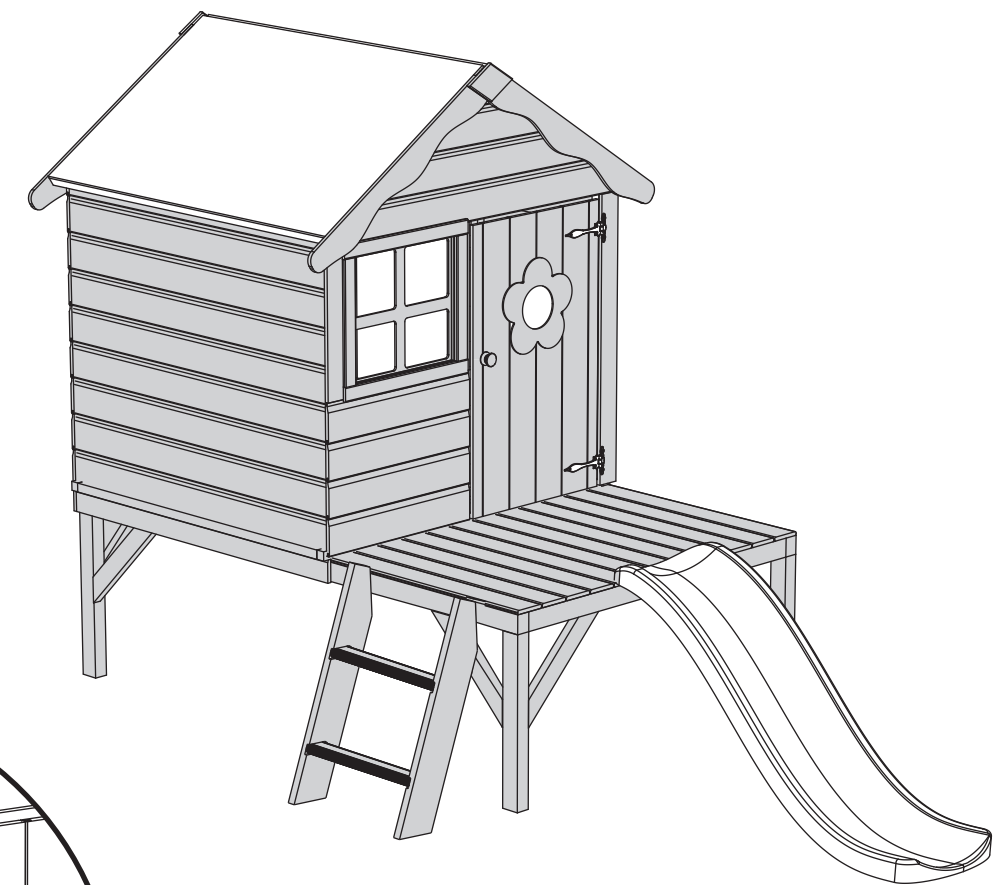
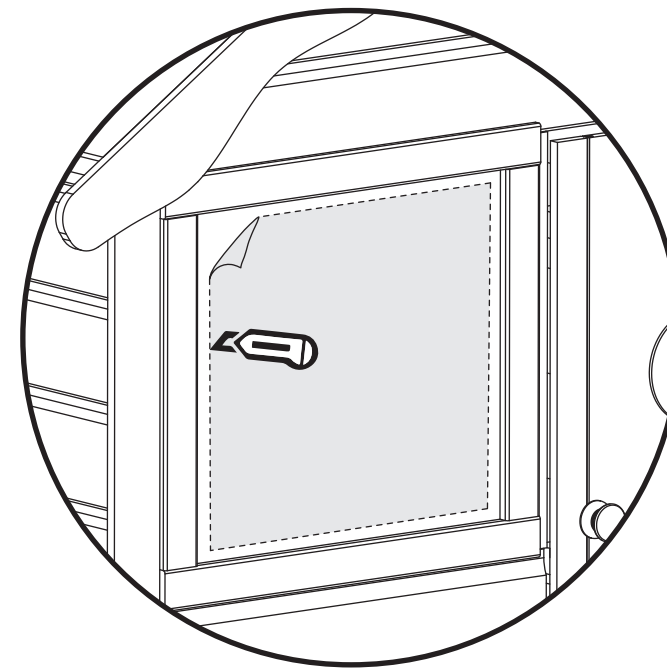

**LEAVE US A REVIEW...**



Want to share your experience with us?  
Leave us a review on Feefo, TrustPilot or Google.

Your reviews help other people find and trust our business, as well as helping to play an important role in our growth and improvement!

## TREATING YOUR GARDEN BUILDING

Preservation of wood that's outdoors is vital. A little early care will help protect your garden building, improve its appearance and ensure maximum longevity. Insects, moisture, salt, and changing weather can have dramatic effects on the stability and appearance of your garden building. Once your building is installed, you've checked it over and you're happy with it, you can take a few basic precautions to prepare it for the elements. Treating your garden building helps prevent decay and, by repelling water, discourages the growth of moulds and fungi that could jeopardise the structural integrity of the wood.

**Dip Treated buildings** - Require a preservative treatment to protect against rot and decay and a waterproof treatment to prevent water ingress  
**Pressure Treated buildings** - Require a waterproof treatment to prevent water ingress  
**Log Cabins/Insulated Garden Rooms** - Are supplied untreated and require a preservative and waterproofing treatment.



**ANY QUESTIONS?**  
Scan the QR code to contact us via our customer portal.

To apply a preservative and water proofing treatment (pressure treated products do not require a preserver), follow the manufacturer's instructions but in principle, stick to the following steps:

- ✓ Weather permitting, ensure to treat your garden building within 14 days of installation.
- ✓ Wear latex or rubber gloves, eye protection and (if spraying) a mask.
- ✓ Prepare the wood, by sanding down any ridges or inconsistencies in the wood, smoothing out knots and end-cuts.
- ✓ Choose a dry day to treat your garden building. If you're spraying rather than brushing paint on, avoid a windy day.
- ✓ Be sure you can safely reach all the sections you need to paint - and if you need a ladder, make sure it's safely positioned before climbing. Lay dust sheets around to avoid paint splatters on your base or surrounding plants.

- ✓ Tape around windowpanes to avoid smears when you're painting the frames.
- ✓ Keep pets and small children out of the way. The last thing you want is to have fur on your garden building paint, or little painted footprints all over your garden and home.
- ✓ Fill any gaps in the building's body with caulk or wood filler to prevent water and draughts getting in. Silicone based caulk is flexible and will move with the timber when temperature and humidity change. Allow to dry completely before treating. A handy tip for finding gaps is to go into your garden building and look for light leaking through joints and frames. If light gets in, then so will water.
- ✓ Liberally apply at least two coats of the treatment products with a brush or spray, taking care to allow the first coat to completely dry before applying the second.
- ✓ Make sure the solution permeates the whole of the surface area, especially around natural cracks, end cuts and nail/screw holes.



APPLY WOOD TREATMENT  
**IMMEDIATELY**  
AFTER ASSEMBLY



## 1 Perimeter

Check around the perimeter of your product to ensure there are not trees or plants that are in contact with or overhanging the building. This can affect airflow and overhanging trees, or branches can damage the roof, it is advised to keep plants at a distance.

## 2 Repair

Inspect the interior and exterior of the product to look for splits, cracks, and holes. Although this is a natural occurrence it can be prevented. A wood filler can be used to close the splits, cracks, and holes.

## 3 Roof

Check your roof regularly for tears, splits, damaged wood and fallen debris. If you notice any of this immediate repair is critical.

## 4 Doors & Windows

Expansion and contraction can cause doors and windows to stick or become difficult to open. Small adjustments to the hinge position can be made to the doors and windows to allow free movement.

## 5 Oil

Hinges can seize up over time, apply lubricant to the hinges and locks annually.

## 6 Screws & Bolts

It is advised to check all screws and bolts and tighten any loose you might find. For log cabins specifically the storm braces will require loosening. During humidity and temperature changes (seasons) to allow expansion and contraction to prevent gaping, twisting, popping, and warping.

## 7 Wash

At least once a year, give the outside of your building a good wash, to remove cobwebs, leaves, or any other dirt that may accumulate on the exterior.

## 8 Airing

Airing your product regularly prevents the build up of condensation which can cause the timber to warp, bow, boards to pop, distortion, rot and mould. Condensation can build up over time or daily, it is caused by a rise and fall in temperature.

Excessive moisture levels within your building can cause water to collect on the roofs, walls and floors internally. Leaving doors and windows open regularly can help combat the natural moisture build up.

## 9 Clean & Tidy

It is good practice to clean the inside and outside of your product regularly. Clear out the contents, sweep the floor, remove dirt and cobwebs. Check for areas of damp and investigate the cause to remove and prevent future occurrences. Check the ground around your product for build up of debris such as leaves, remove and ensure there is clear ventilation underneath the floor.

### Additional Playhouse Maintenance:

It is recommended that the following checks and maintenance are carried out at the beginning of each season as well as at regular intervals during the usage season.

- Check all nuts /bolts/ screws for tightness and tighten when required.
- Check for movement / opening of wood giving rise to protrusion of nail heads and tips.
- Check hinges.
- Replace defective parts in accordance with the manufacturers instructions.
- Check any crossbeams, suspensions and anchors.
- If a swing is included; check the swing seat, chains and ropes.

**IF THESE CHECKS ARE NOT CARRIED OUT THE ACTIVITY TOY COULD BECOME A HAZARD**



All our garden buildings have been designed and manufactured with care and attention to be the perfect addition to your outdoor space. To ensure you do get the best out of your new garden building and to increase the longevity we advise that you follow the product instructions and our manufacturer's recommendations as detailed below. Thank you for choosing a Mercia Garden product!

## 1 Choosing the most suitable location for your garden building...

A minimum of 60cm should be left around the perimeter of your garden building to allow access for maintenance, annual treatment and to allow air flow around the building.

Where possible you should avoid placing your garden building underneath large trees to prevent the tree causing damage to the building.

## 2 Preparing the base for your garden building...

All our buildings must be built on a firm, level base to ensure the longevity of the building and prevent the wood from distorting. We recommend either concrete, concrete slabs or a wooden base, such as our 'Portabase'.

The base should be slightly smaller than the external measurement of the building, i.e. the cladding should overlap the base, creating a run off for water and preventing water from pooling underneath the building.

We also recommend that the floor of the garden building is a minimum of 25mm above the surrounding ground level to avoid flooding.

## 3 After installation...

Once your garden building has been installed, it will need to be treated within 14 days (weather permitting) and annually to prevent the timber from deteriorating and to waterproof it. This is required to maintain the anti-rot guarantee.

Dip Treated buildings - Require a preservative treatment to protect against rot and decay and a waterproof treatment to prevent water ingress.

Pressure Treated buildings - Require a waterproof treatment to prevent water ingress.

Log Cabins/Insulated Garden Rooms - Are supplied untreated and require a preservative and waterproofing treatment.

We also recommend using a silicon sealant on the inside and outside of the windows as soon as possible after assembly and treatment to fully seal the windows.

Roofing felt/covering should be checked annually and replaced or fixed accordingly.

## 4 General maintenance and wood characteristics

As wood is a natural material it may be affected by the following:

Shrinkage and warping - The timber used in the construction of your garden building will have retained some of its natural moisture content. The moisture content of the timber will vary, depending upon prevailing environmental conditions, which will result in the components either naturally expanding or contracting. As the components dry out, shrinkage may occur. A good waterproofing treatment from the start is the best protection to minimise the effect of moisture loss/intake.

In extended periods of very warm weather getting some moisture to the building will help the overall balance. You can do this by spraying it down lightly with a garden hose. In contrast, after snow fall try to remove the snow as best as possible from the roof to prevent moisture intake and to remove the extra weight.

**Top tip** - using a garden brush will help you to reach the highest part of the building to remove snow and any debris left from bad weather.

Damp and mould - During the winter months, cold and damp conditions can result in an increased amount of moisture within your garden building, especially when used infrequently. Condensation can form on the timber and other items stored within your garden building. If left this moisture is likely to cause mould and mildew.

To prevent the build-up of moisture, we recommend leaving the door or windows of your building open from time to time, to allow the fresh air to circulate. We also advise against storing wet or damp items in your garden building as this will also increase the level of moisture in the building. If mould or mildew does start to form within your building we recommend using an anti-mould cleaner to remove it and to prevent it spreading, which if left untreated could permanently damage your garden building.

Splits, cracks and knots - You may notice small splits and cracks in some components or holes may appear where knots shrink and fall out. This will not affect the structure of your Garden building however, if you wish to fill them this can be easily done using any good quality wood filler.

Sap - is naturally occurring in wood and may appear in some boards of your garden building. If you wish to remove the sap, we advise waiting until it is dry and then using a sharp knife to carefully remove it. If the removal of the sap causes a hole in the timber, we recommend using a good quality wood filler to fill it.

For more handy hints and tips on how to care and maintain your garden building please refer to the MGP Customer Portal at [www.mgplogistics.co.uk](http://www.mgplogistics.co.uk)

### Any further questions?



Contact our Customer Service Team via the MGP Customer Portal at: [www.mgplogistics.co.uk](http://www.mgplogistics.co.uk)

1

## Manufacturer's Warranty

All Mercia Garden Products are supplied with a 1 year warranty on all parts against manufacturing defects.

This warranty does not cover movement, warping or splitting of timber products over time.

This warranty will be voided if any of the following occur:

1. The building has been customised or modified/adapted in any way.
2. The person claiming is not the original purchaser of the building.
3. Any damage has been caused by or as a result of misuse.
4. The building has not been maintained and cared for in accordance to our advisories and manufacturer's recommendations.
5. The building has not been treated annually or as per the manufacturer's recommendations, please ensure receipts are kept to validate this claim.
6. The building has not been erected, fitted or installed as per the supplier instructions.
7. The building has not been erected on a suitable sized firm flat, solid level concrete/slab base or placed on pressure treated bearers.
8. The building is or has been placed with 2 feet (600mm) of any obstructions (walls, trees, plants, fences etc.) which can allow moisture to penetrate the timber.
9. The roofing felt has been incorrectly fitted or damaged, allowing water ingress, or has not been properly maintained.
10. Any windows and joints have not been sealed, inside and out, with silicone or other watertight sealant.
11. Any timber has been cut, pierced or drilled without subsequent application of approved cut-end treatment.

REGISTER FOR YOUR  
**10 YEAR**  
**ANTI-ROT**  
GUARANTEE TODAY



[www.mgplogistics.co.uk](http://www.mgplogistics.co.uk)

2

## Anti-rot Guarantee

Mercia Garden Products offer a 10 year anti-rot guarantee on all dip treated (a preparatory treatment) and 15 years on all pressure treated products. This guarantee covers solid timber against rot, decay, blue stain and insect attacks.

To validate the guarantee, the building must be treated (as detailed within manufacturer's recommendations) within 14 days (weather permitting) of assembly and annually thereafter.

This guarantee does not cover movement, warping or splitting of timber products over time.

This guarantee will be voided if any of the following occur:

1. The building has been customised or modified/adapted in any way.
2. The person claiming is not the original purchaser of the building.
3. Any damage is caused by or as a result of misuse.
4. The building has not been maintained and cared for in accordance to our advisories and manufacturer's recommendations.
5. The building has not been treated annually or as per the manufacturer's recommendations, please ensure receipts are kept to validate this claim.
6. The building has not been erected, fitted or installed as per the supplier instructions.
7. The building has not been erected on a suitable sized firm flat, solid level concrete/slab base or placed on pressure treated bearers.
8. The building is or has been placed with 600mm of any obstructions (walls, trees, plants, fences etc.) which can allow moisture to penetrate the timber.
9. The roofing felt has been incorrectly fitted or damaged allowing water ingress, or has not been properly maintained.
10. Any windows and joints have not been sealed, inside and out, with silicone or other watertight sealant.
11. Any timber has been cut, pierced or drilled without subsequent application of approved cut-end treatment.