

01D TOVAX08DDNWGP-V1
8FT WIDE OVERLAP APEX SHEDS

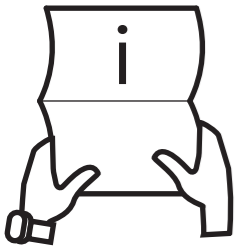

BEFORE YOU START PLEASE READ THE INSTRUCTIONS CAREFULLY

- Check the pack and make sure you have all the items listed in the parts list provided.
- When you are ready to start, make sure you have the right tools at hand (not supplied - see the equipment list on next page).
- Ensure there is plenty of space and a clean dry area for assembly.
- Ensure you have enough time to build the product to ensure the building is water tight.

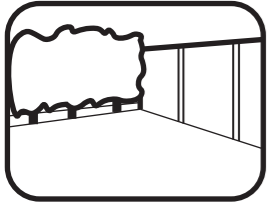

LOCATION FOR YOUR GARDEN BUILDING

A minimum of 600mm should be left around the perimeter of your garden building to allow access for maintenance, annual treatment and to allow air flow around the building.

Where possible you should avoid placing your garden building underneath large trees to prevent the tree causing damage to the building.

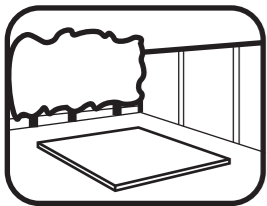

BUILDING A BASE

When thinking about where the building and where the base is going to be constructed: Ensure that there will be access to all sides for maintenance work and annual treatment.

Ensure the base is level and is built on firm ground, to prevent movement. Refer to the contents page for the base dimensions. The base should be slightly smaller than the external measurement of the building, i.e. The cladding should overlap the base, creating a run off for water. It is also recommended that the floor be at least 25mm above the surrounding ground level to avoid flooding.

TYPES OF BASE

- Concrete 75mm laid on top of 75mm hard-core.
- Slabs laid on 50mm of sharp sand.
- Wooden base - Levelled / on posts / ground screws.

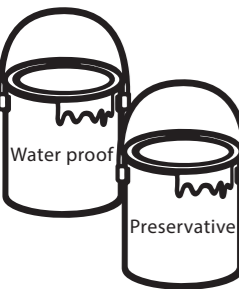

TREATMENT

Once your garden building has been installed it will need to be treated within 14 days (weather permitting) and annually to prevent the timber from deteriorating and to waterproof it. This is required to maintain the anti-rot guarantee.

Dip Treated buildings - Require a preservative treatment to protect against rot and decay and a waterproof treatment to prevent water ingress

Pressure Treated buildings - Require a waterproof treatment to prevent water ingress

Log Cabins/Insulated Garden Rooms - Are supplied untreated and require a preservative and waterproofing treatment.



TIMBER

As with all natural materials, timber can be affected during various weather conditions. For the duration of heavy or extended periods of rain, swelling of the wood panels may occur. Warping of the wood may also occur during excessive dry spells due to an interior moisture loss. Unfortunately, these processes cannot be avoided but can be helped. It is suggested that the outdoor building is sprayed with water during extended periods of warm sunshine and sheltered as much as possible during rain or snow.

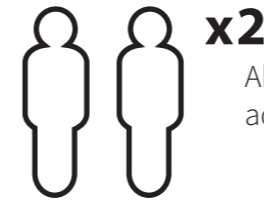

x2

All buildings should be erected by two adults.



2mm Drill bit

For ease of assembly, you **MUST** pilot drill all screw holes and ensure all screw heads are countersunk.



For ease of assembly, you will need a tape measure to check dimensions of components and fixings.



Winter = High Moisture = Expansion
Summer = Low Moisture = Contraction



CAUTION

Every effort has been made during the manufacturing process to eliminate the prospect of splinters on rough surfaces of the timber. You are strongly advised to wear gloves when working with or handling rough sawn timber.

****Protim Aquatan T5 (621)****

Your building has been dip treated with Aquatan.

Aquatan is a water-based concentrate which is diluted with water, the building has been treated by the correct application of Aquatan solution and then allowed to dry.

Aquatan is a decorative finish to colour the wood, which is applied industrially to timber fence panels and garden buildings.

Aquatan undiluted contains: boric acid, sodium hydroxide 32% solution, aqueous mixture of sodium dioctyl sulphosuccinat and alcohols: 2, 4, 6-trichlorophenol.

REGISTER FOR YOUR
10 YEAR
ANTI-ROT
GUARANTEE TODAY

In all instances for assistance with your product or to register your anti rot guarantee, please contact us via our customer portal



www.mgplogistics.co.uk

Mercia Garden Products Limited, Sutton On Trent, Newark, Nottinghamshire, NG23 6QN

Screws & Nails

Measure overall length

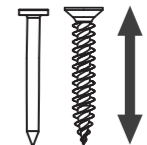

Bolts

Measure under the head

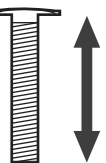

TO DO LIST

- Find a suitable location to build (*see front cover for further information*).
- Build a base (*see front cover for further information*).
- Check the base is flat, level, clear of debris and has 60cm clearance on all sides.
- Check you have the required equipment / tools.
- Check you have all the product items listed (*if you have missing or damaged parts please scan the QR code below to visit our online customer portal*).
- Install the product as per the step by step instructions within this pack.
- Prepare the product ready for treatment (this may include sanding).
- Apply a preserving and a waterproofing treatment within 14 days (*weather permitting*) of installation (*pressure treated products do not require a preserver*).
- Register for your anti rot guarantee (*scan the QR below*).
- Tidy the build area and dispose of any remaining parts responsibly.
- Maintain your building (*see the manufacturers recommendations at the back of this pack*).

EQUIPMENT LIST

- Hammer
- Flat Head Screwdriver
- Drill
- Drill Bit Set
- Phillips and Slotted Bit Sets
- Tape Measure
- Hand Saw
- Spirit Level
- Ladders/Steps
- Stanley Knife/Cutting Tool
- Sand Paper
- Gloves
- Silicone (For Windows Only)
- Sealant Application Gun
- Wood Filler (Optional)
- Timber Preservative Treatment (*not pressure treated products*)
- Timber Water Proofing Treatment
- Treatment Mixing Stick
- Paint Brush/Sprayer/Roller

NEED EXTRA SUPPORT

If you are unsure that your base preparation will be suitable, please contact us via our customer portal to discuss this further.

Alternatively, you can visit our website or MGP Logistics Online Portal for some further shededucation.

Website:

<https://www.merciagardenproducts.co.uk/sheducation>

MGP Logistics Online Portal:

<https://www.mgplogistics.co.uk/>

Here you will find plenty of useful information that'll help with most pre-installation and maintenance queries.

**ANY QUESTIONS?**

Scan the QR code to contact us via our customer portal.

NOTES

ACCESSING VIDEO GUIDES...

Some steps within this set of instructions come with an added video guide for your convenience. These can be accessed via the QR code and used to aid you in constructing that step. See below for how to use.

You can also find all the videos on our youtube channel:
<https://www.youtube.com/@merciagardenproducts8716/videos>

1. Find the QR code within the instruction step...

Step.....

Parts Needed- No. QTY 1
No. QTY 1
No. QTY 1

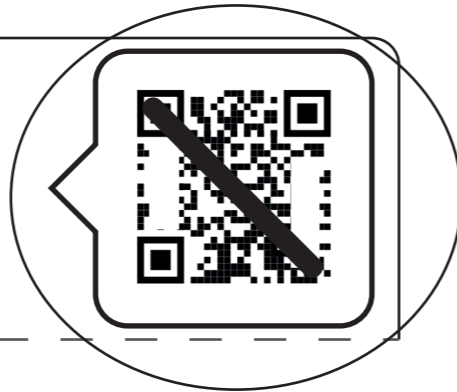

Within the instruction step, there will be an icon in the top right that has a QR code in. This is where the video can be accessed from.

Please note: not every step has a video guide.

2. Open camera app...

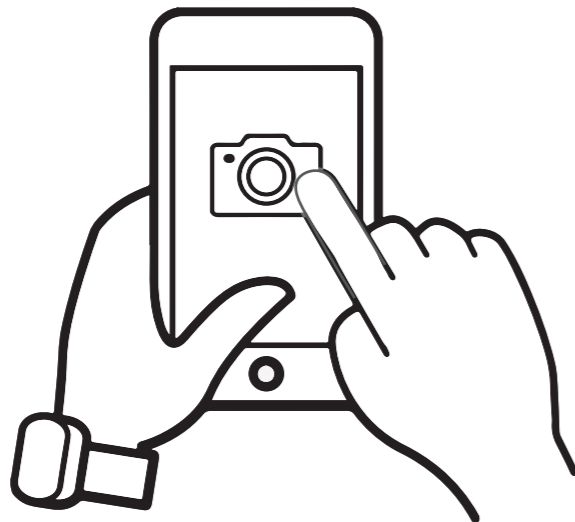

On your personal smart device (phone, tablet etc), open your camera app or QR code scanner app.

ACCESSING VIDEO GUIDES...

3. Scan QR code...



To scan the QR code, hold the camera over the QR code so that it can be seen on the screen. Once the QR code has been registered, follow the prompts on your device to open the video. (This will vary depending on your device.)

Please note: Ensure to use the back camera of your smart device as this will scan the QR code more accurately.

4. Watch the video...



The video guide will now be displayed on your smart device.

Disclaimer: The garden building constructed in the video guides may be constructed differently to your building. Please ensure to read your instructions carefully to avoid error.

10x8ft

Overall Dimensions:
Width = 2484mm
Depth = 2966mm
Height = 2118mm

Base Dimensions:
Width = 2350mm
Depth = 2912mm

10x8 Fixed Window

Pack Requirements:
01D TOVAX08DDNWGP-V1 QTY 1
01D TOVAX0508FWPB-V1 QTY 2

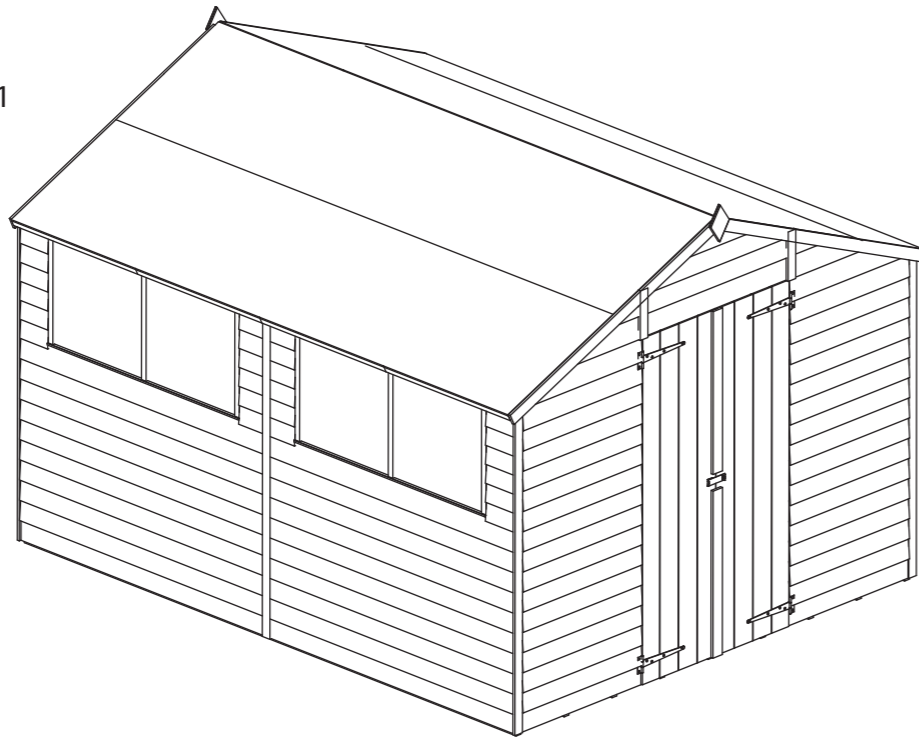

10x8 No Window

Pack Requirements:
01D TOVAX08DDNWGP-V1 QTY 1
01D TOVAX0508NWPB-V1 QTY 2

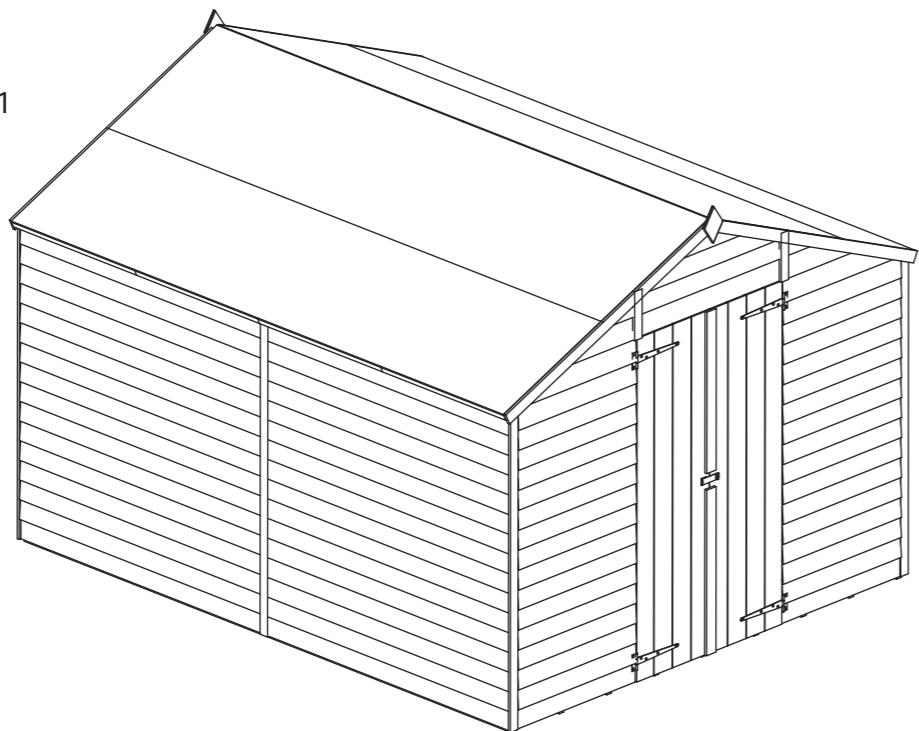

12x8ft

Overall Dimensions:
Width = 2484mm
Depth = 3570mm
Height = 2118mm

Base Dimensions:
Width = 2350mm
Depth = 3506mm

12x8 Fixed Window

Pack Requirements:
01D TOVAX08DDNWGP-V1 QTY 1
01D TOVAX0608FWPB-V1 QTY 2

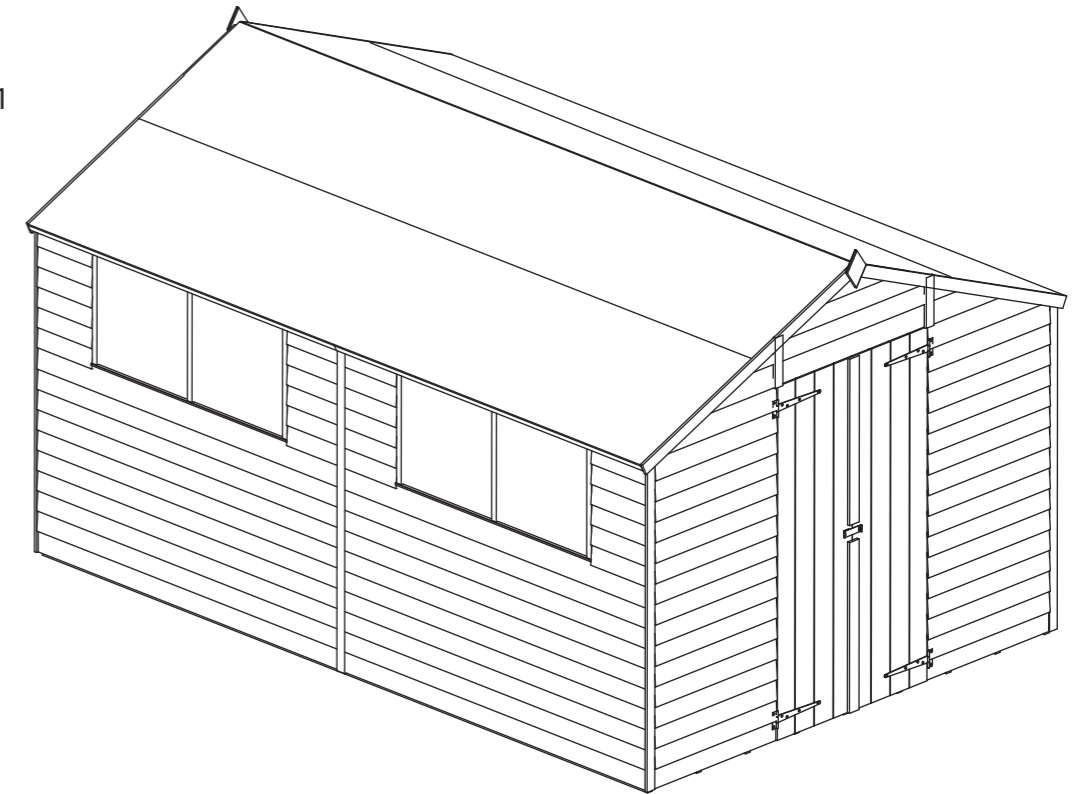

12x8 No Window

Pack Requirements:
01D TOVAX08DDNWGP-V1 QTY 1
01D TOVAX0608NWPB-V1 QTY 2

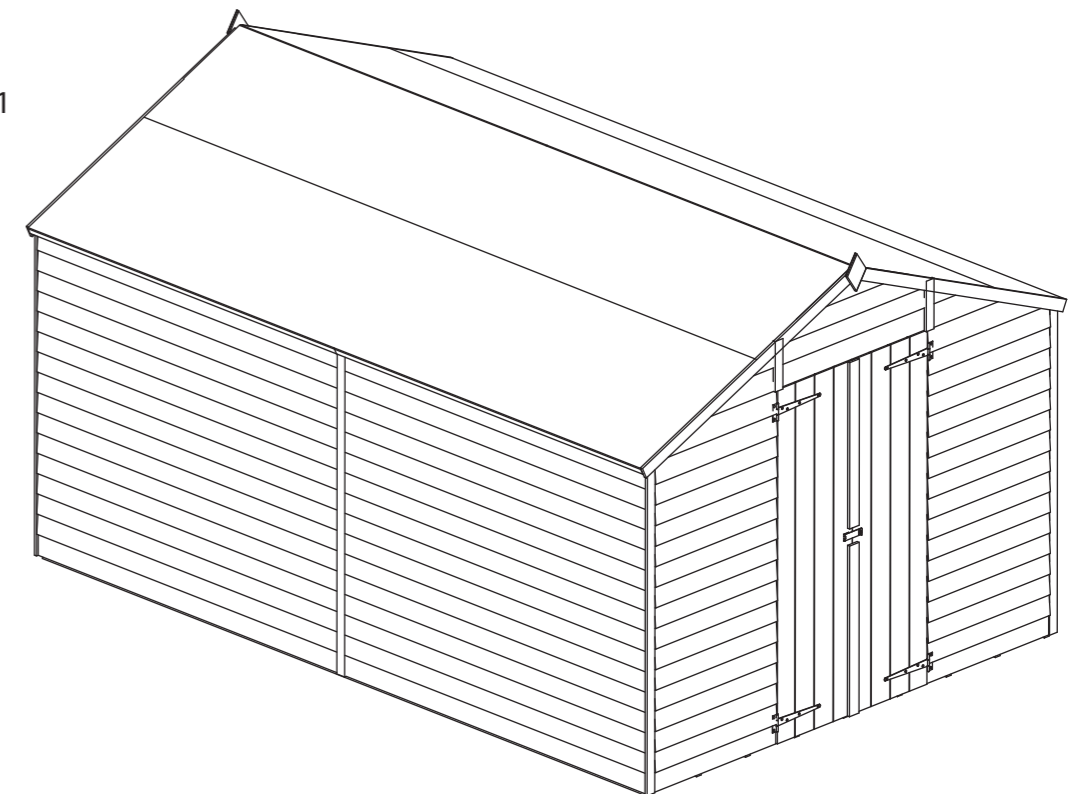

Tip: Labelling your parts, using a pencil and masking tape, may help you to identify them easier when you need them.

NO.1 FLOOR PANEL

Building Content - Gable Pack

01DVOVAX08DDNWGP-V1

1

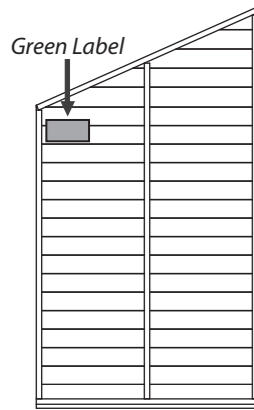

Back Gable Right QTY 1
AI-01R11OVPGR1155X2089-V1

2

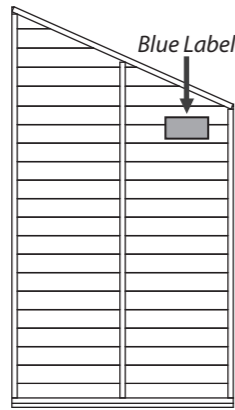

Back Gable Left QTY 1
AI-01R11OVPLG1155X2089-V1

3

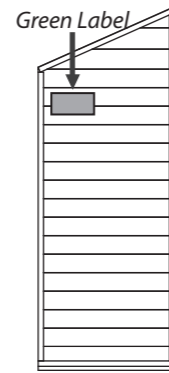

Front Gable Right QTY 1
AI-01R11OVPGR713X1897-V1

4

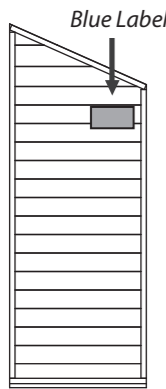

Front Gable Left QTY 1
AI-01R11OVPLG713X1897-V1

5



Door QTY 2
AI-R11FBMBZBD437X1660-V1

6

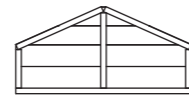

Gable Top QTY 1
AI-R11OVAGT884X439-V1

7

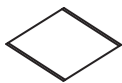

Diamond Finial QTY 2
SHED DIAMOND FINIAL

8



T Hinge QTY 4
PI-02-1043

9



Corner Brace QTY 2
PI-07-0012

10



Turn Button QTY 2
PI-07-0034

11



U Channel QTY 1
PI-07-0013

12



Hasp and Staple QTY 1
PI-07-0207

13



Door Block - 28x28x150mm QTY 4
F2828-150mm

14



Truss Block - 27x44x140mm QTY 2
F2744-G-160mm

15



Gable Cover Strip - 7x125x1943mm QTY 1
OVL7125-P-1943mm

16

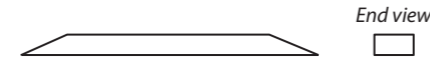

Truss Support - 27x44x450mm QTY 1
F2744-G-490mm

17

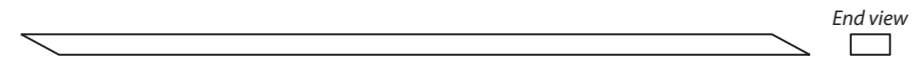

Truss Framing - 27x44x1262mm QTY 2
F2744-G-1302mm

18

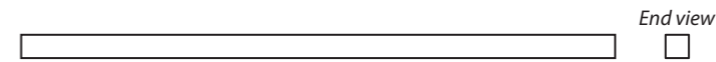

Door Framing - 28x28x884mm QTY 1
F2828-884mm

19

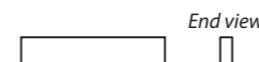

Front Panel Cover Strip - 12x45x237mm QTY 2
S1245-237mm

20

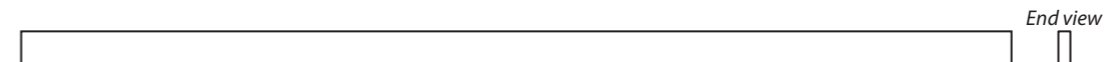

Panel Cover Trim - 12x45x1542mm QTY 6
S1245-1542mm

21

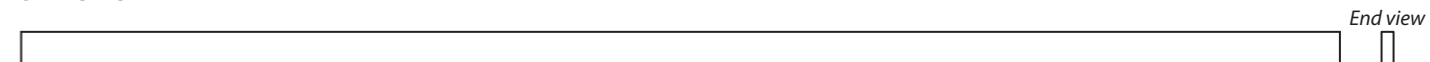

Back Panel Cover Strip - 12x45x2030mm QTY 1
S1245-2030mm

22

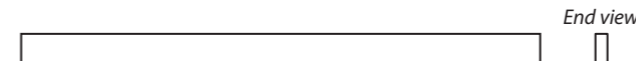

Door Cover Strips - 12x56x780mm QTY 1
S1256-780mm

23

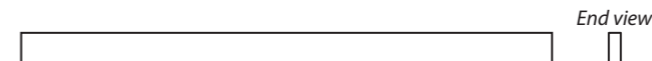

Door Cover Strips - 12x56x800mm QTY 1
S1256-800mm

24

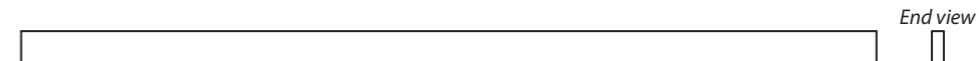

Fascias - 12x56x1333mm QTY 4
S1256-1333mm

25

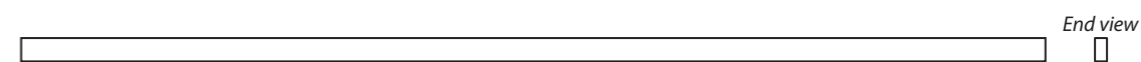

Door Beading Strip - 12x28x1558mm QTY 2
S1228-1558mm

Screw Pack:

There may be extra screws in the pack.

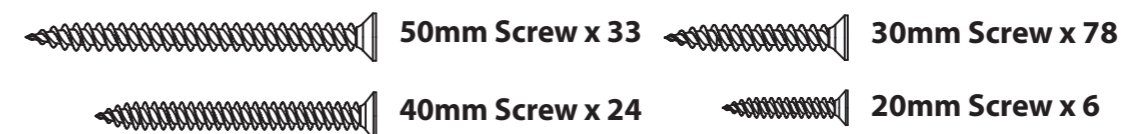

Contents for packs to create a 10x8 shed:

Building Content- 10X8 Pack B With Window

Window Pack - 01DTOVAX0508FWPB-V1

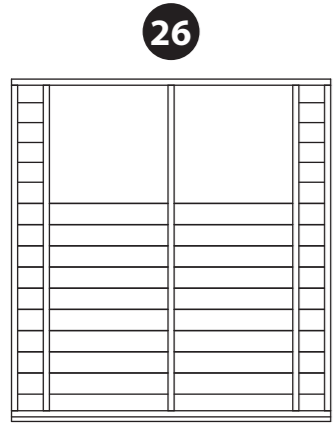

Window Panel QTY 1
AI-01R11OV2CW1461X1567-V1

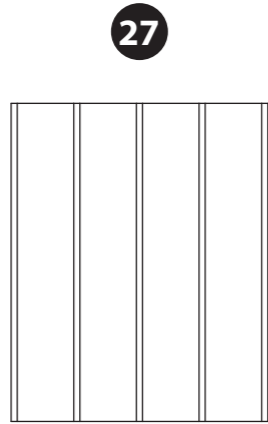

Floor QTY 2
AI-R11OSBF1175X1456-V1

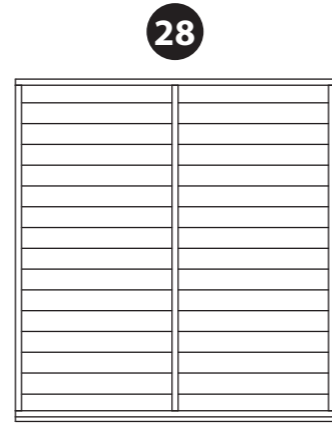

Plain Panel QTY 1
AI-R11OVPP1461X1567-V1



Roof Sheet QTY 4
1356 X 735mm
PI-03-0388

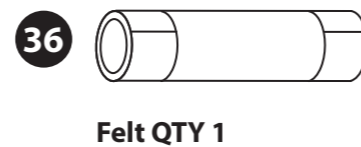
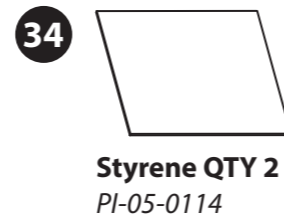
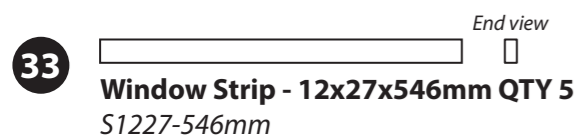
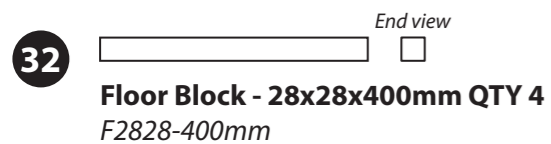
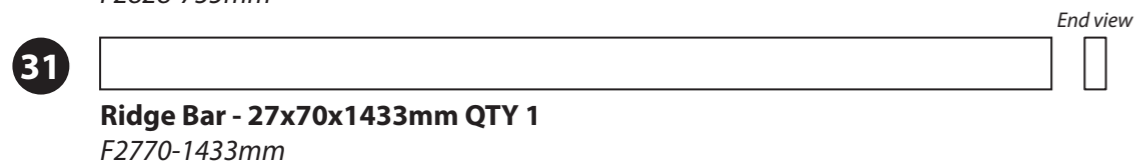
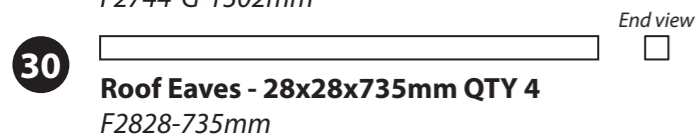
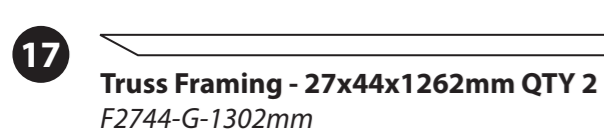
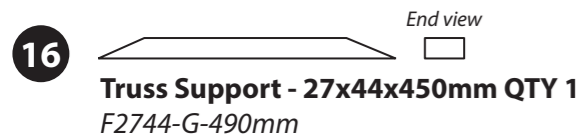
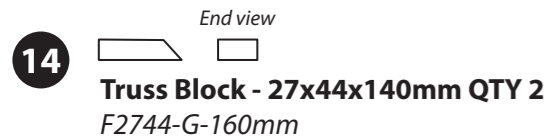

Screw Pack:

There may be extra screws in the pack.

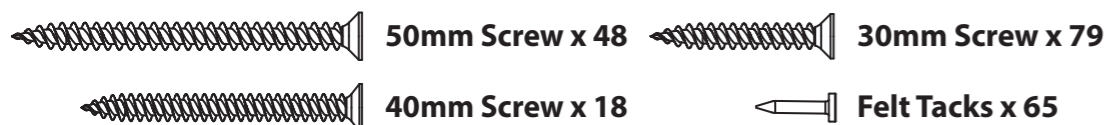

Building Content- 10X8 Pack C No Window

No Window Pack - 01DTOVAX0508NWPB-V1

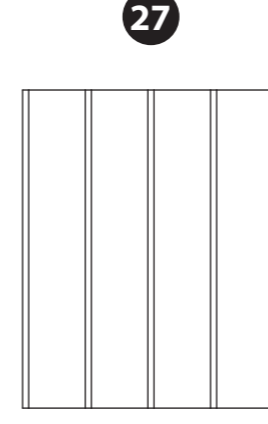

Floor QTY 2
AI-R11OSBF1175X1456-V1

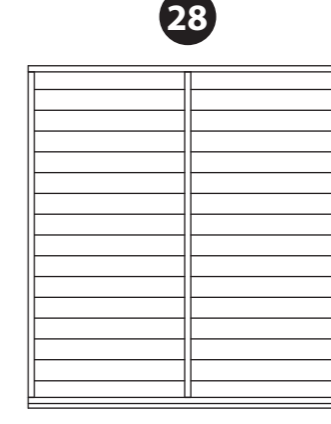

Plain Panel QTY 2
AI-R11OVPP1461X1567-V1

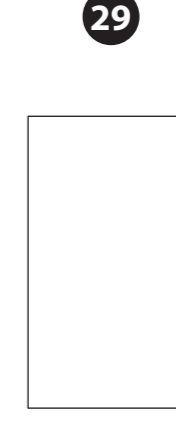

Roof Sheet QTY 4
1356 X 735mm
PI-03-0388

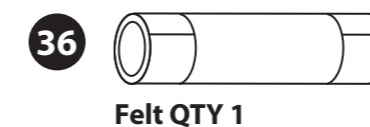
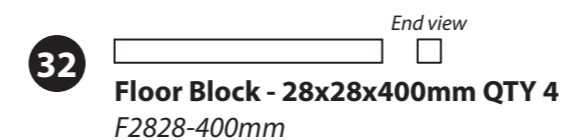
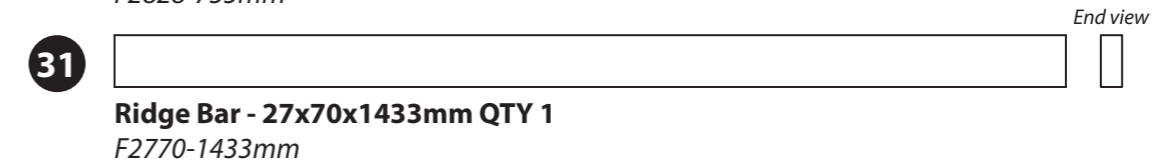
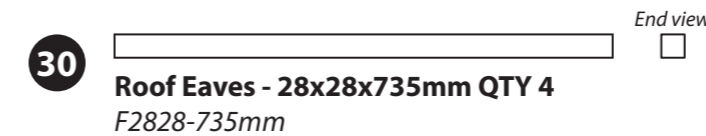
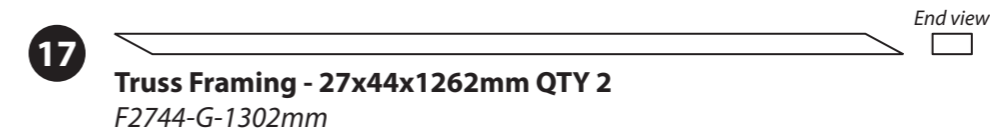
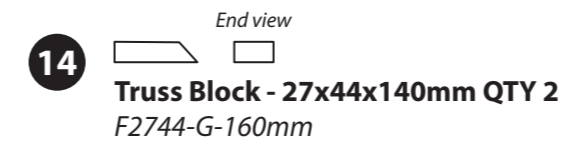

Screw Pack:

There may be extra screws in the pack.

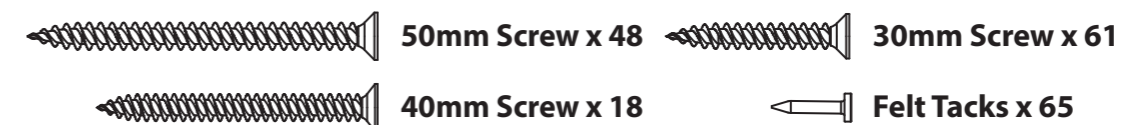

Contents for packs to create a 12x8 shed

Building Content- 12X8 Pack B With Window

Window Pack- 01DTOVAX0608FWPB-V1

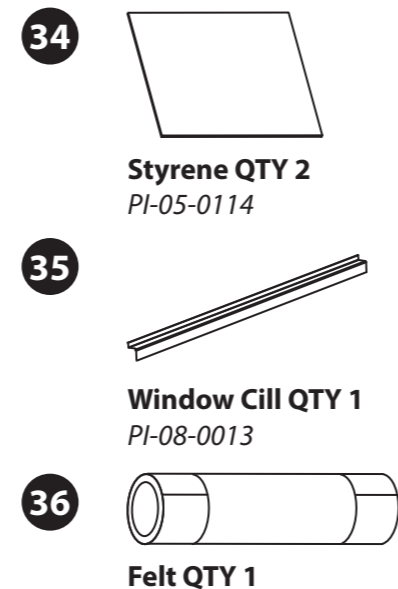
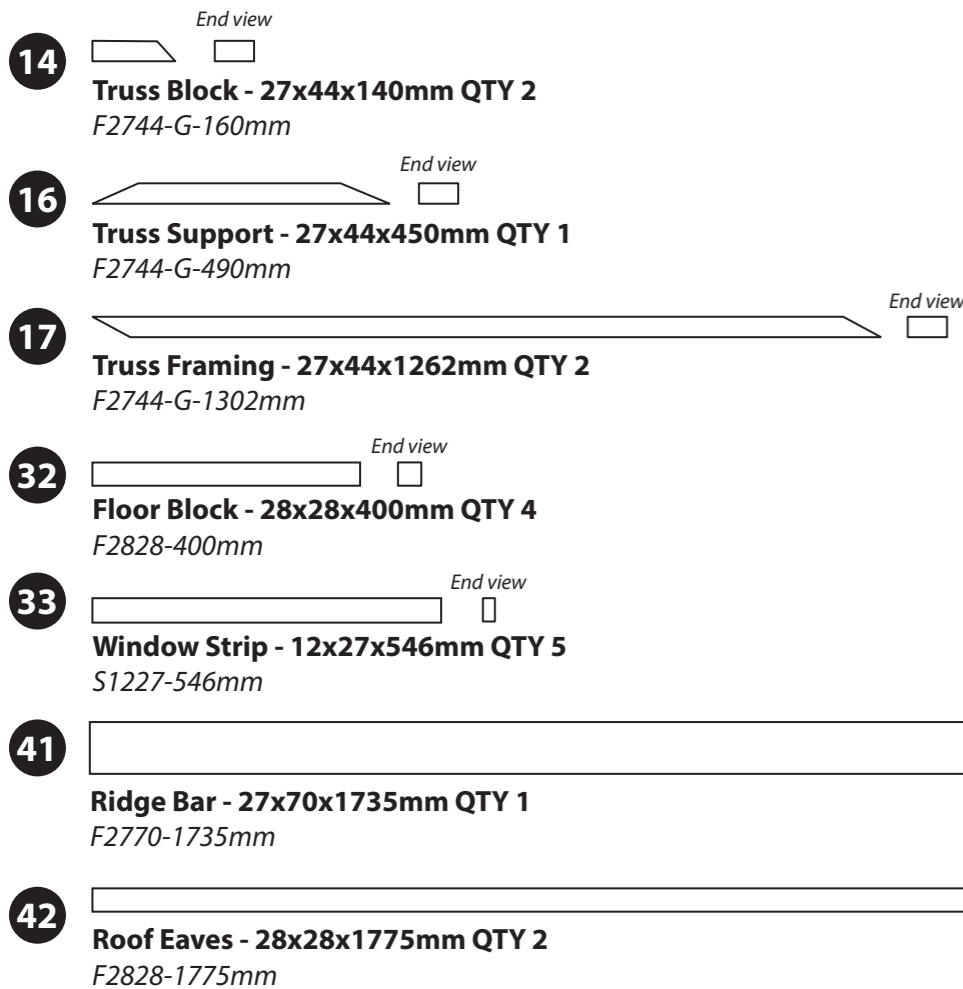
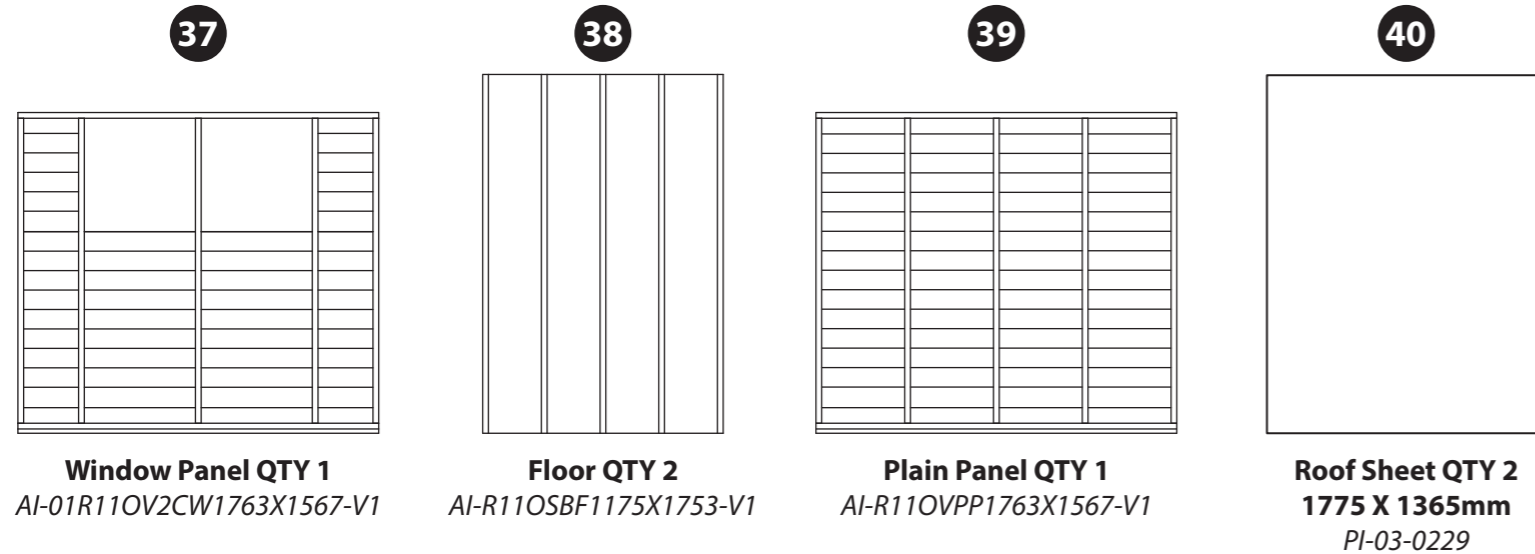

Screw Pack:

There may be extra screws in the pack.

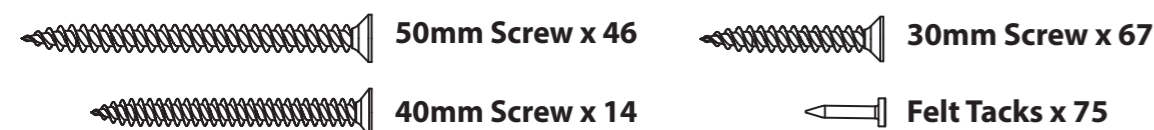

Building Content- 12X8 Pack C No Window

No Window Pack- 01DTOVAX0608NWPB-V1

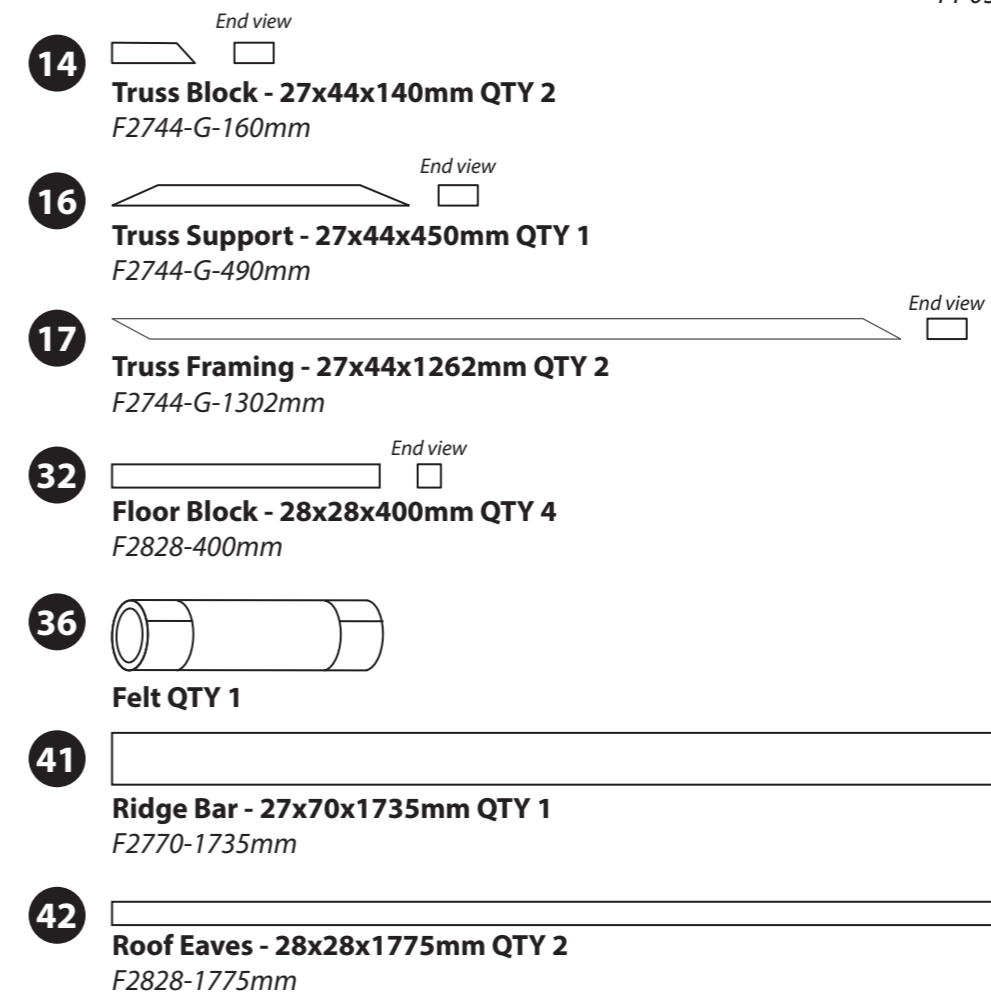
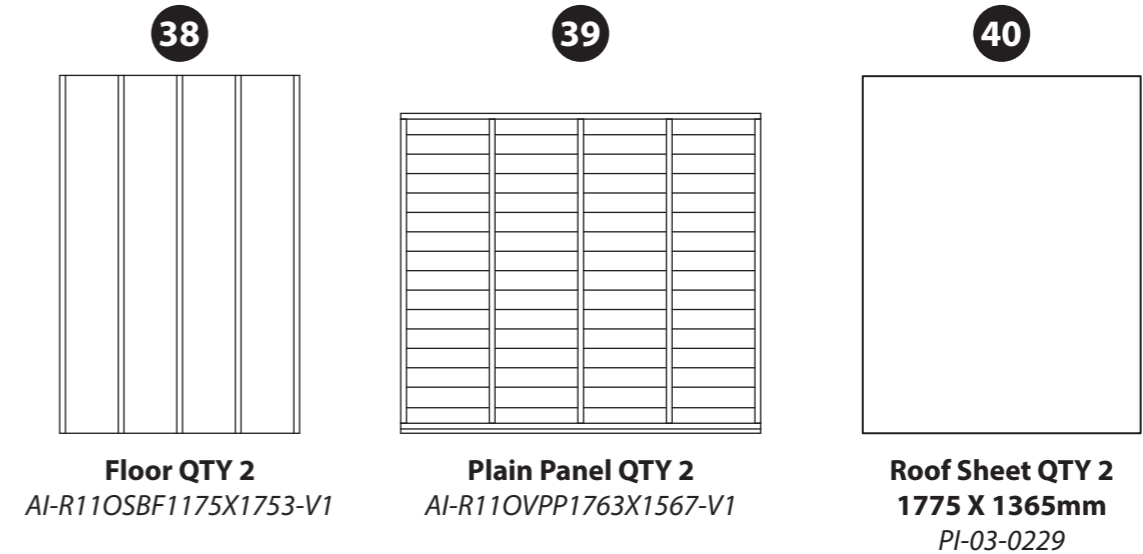

Screw Pack:

There may be extra screws in the pack.

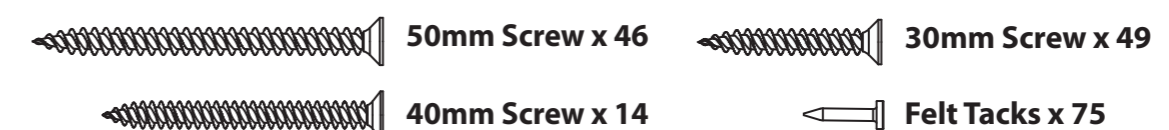

Pre Assembly

Before assembling remove the transportation blocks from the bottom of each panel.

Take care removing the blocks as to not damage the panels. Tap with a flat headed screwdriver and hammer.

Dispose of the blocks once removed.

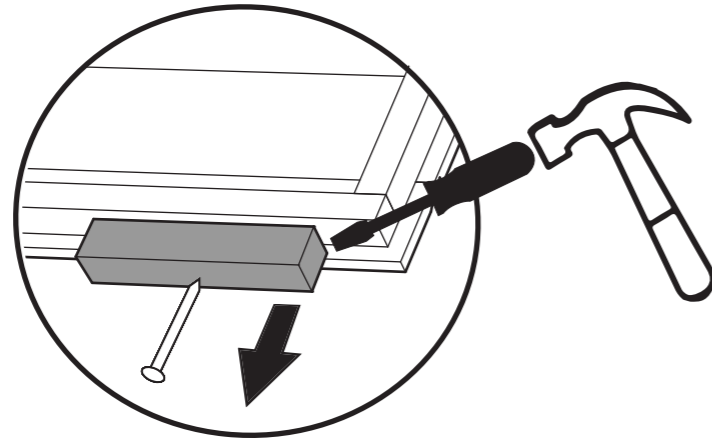

Step 1

Parts Needed - No. 3 QTY 1
No. 4 QTY 1
No. 6 QTY 1

Lay the Front Gable Right and Left (No. 3 & 4) and the Gable top (No. 6) onto a level floor.

Place them along side each other and ensure they are flush along the top of the panels. Secure the panels using 2x50mm screws along each join in an alternating pattern.

4x50mm screws

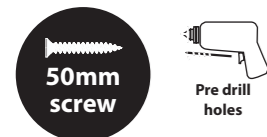

IMPORTANT: Pre-drill before fixing screws.

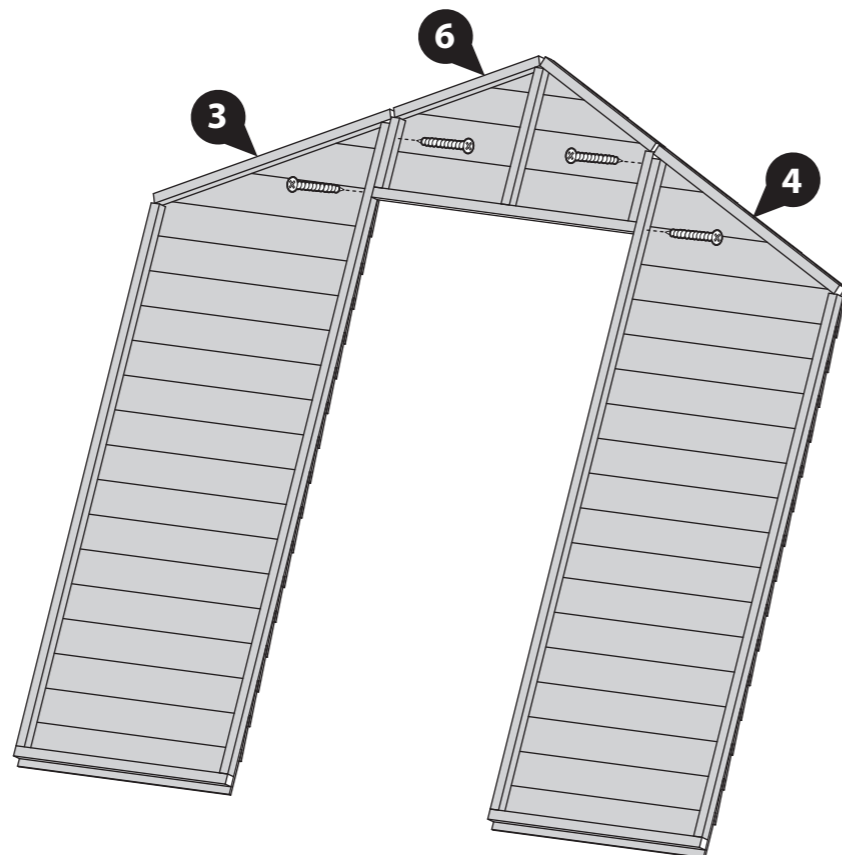

Step 2

Parts Needed - No. 15 QTY 1

Lay the Gable Cover Strip (No. 15) onto the assembled front gable, align the edges of the strip with the top of the gable and secure using 6x40mm screws, ensuring to go through the strip and into the framing.

6x40mm screws

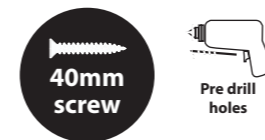

IMPORTANT: Pre-drill before fixing screws.

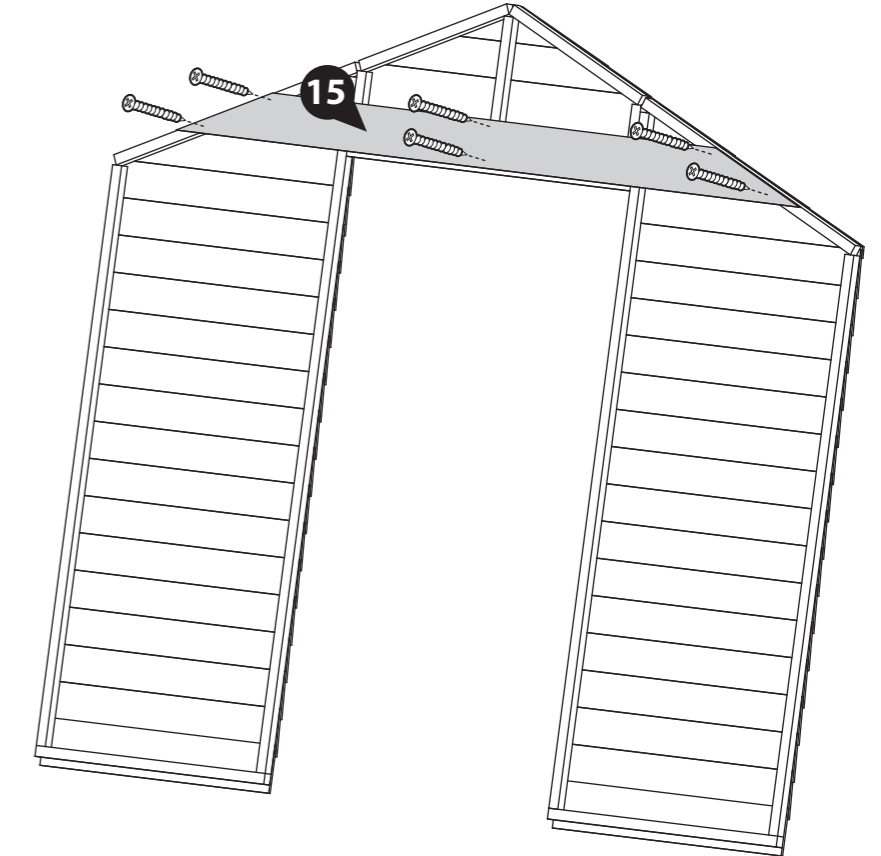

Step 3

Parts Needed - No. 1 QTY 1
No. 2 QTY 2

Lay the Back Gable Right and Left (No. 1 & 2) onto a level floor.

Place them along side each other and ensure they are flush along the bottom of the panels. Secure the panels using 8x50mm screws along each join in an alternating pattern.

8x50mm screws

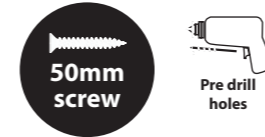

IMPORTANT: Pre-drill before fixing screws.

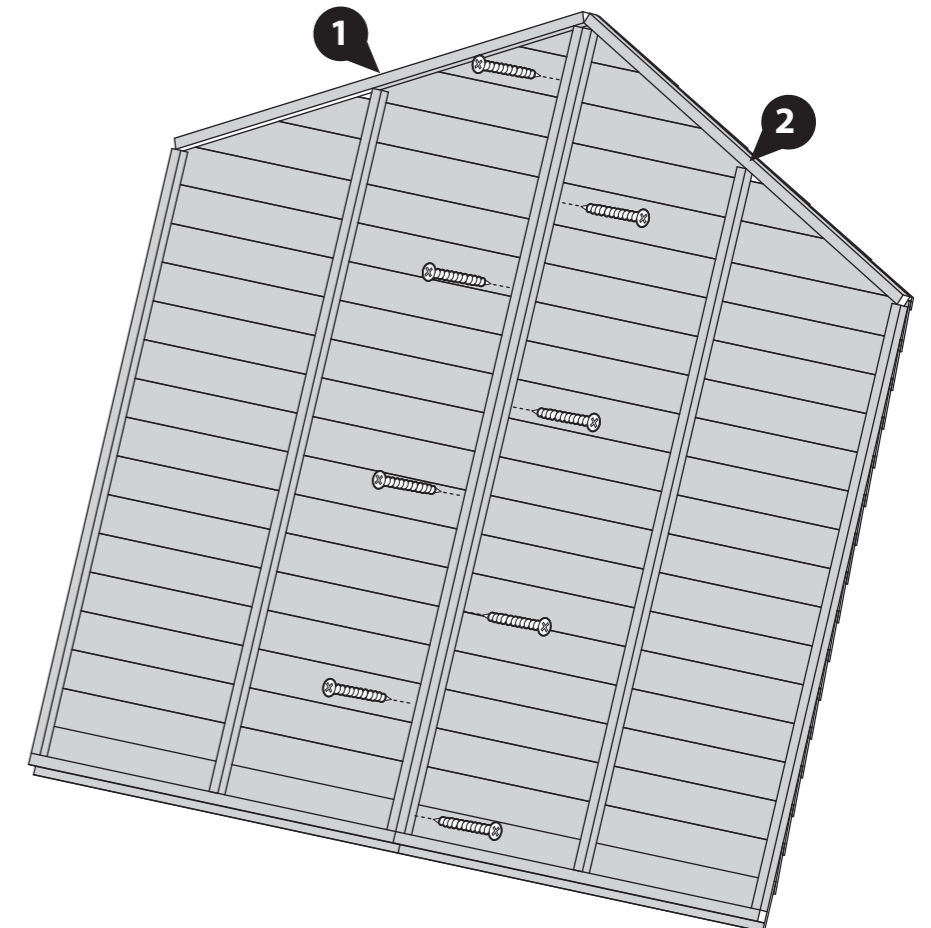

Step 4

Parts Needed 10x8 - No. 27 QTY 4
Parts Needed 12x8 - No. 38 QTY 4

Place the two Floors (No. 27 or No. 38) on firm and level base, ensure the base has suitable drainage free from areas where water can collect.

Attach the floors together using 8x40mm screws (10x8) or 10x40mm screws (12x8).

Repeat the step to create two floor assemblies.

10x8- 16x40mm screws
12x8- 20x40mm screws

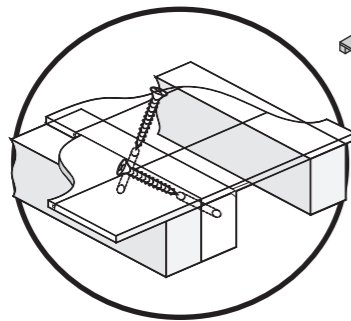

IMPORTANT: Pre-drill before fixing screws.

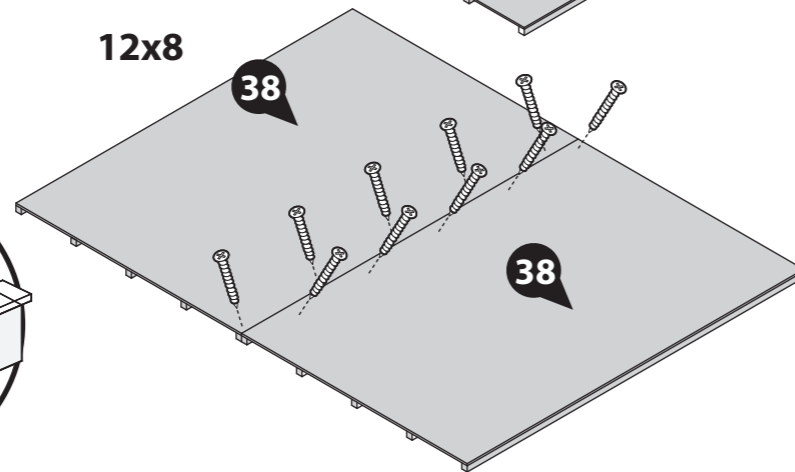
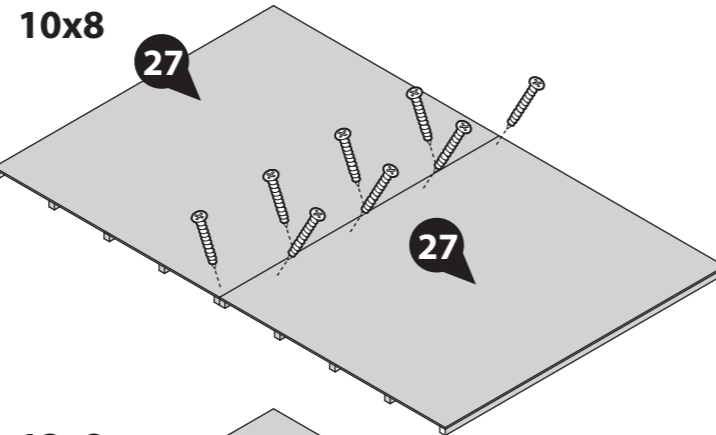

Step 6

Locate the second floor assembly along side the first floor assembly.

Secure to the floor using 2x30mm screws per block, going through the floor OSB and into the floor blocks below.

16x30mm screws

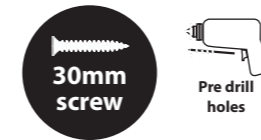

IMPORTANT: Pre-drill before fixing screws.

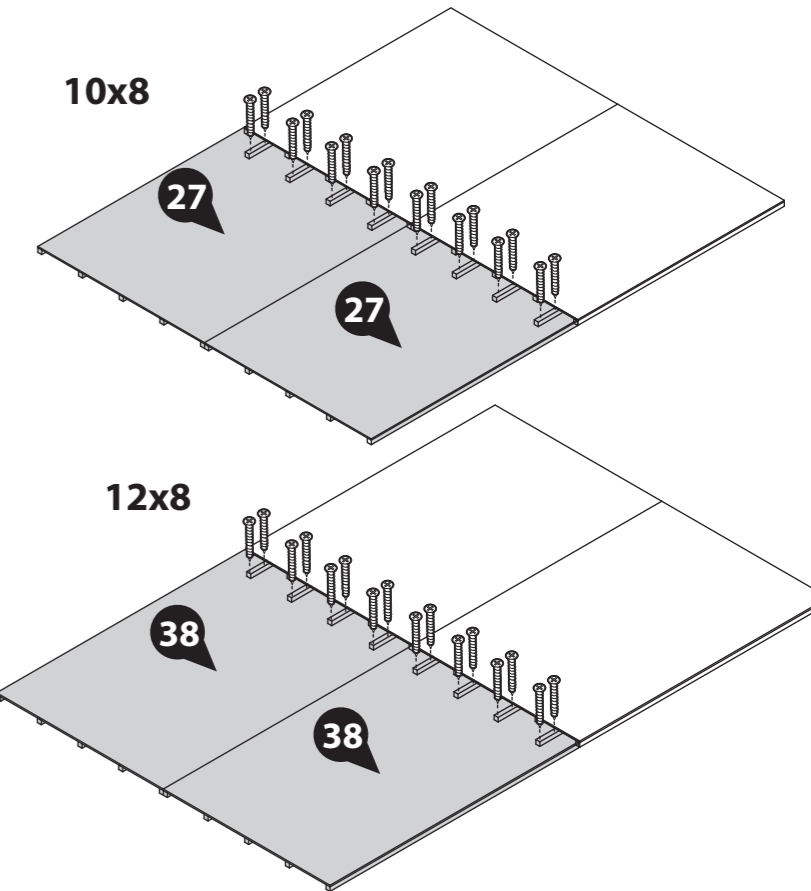

Step 5

Parts Needed - No. 32 QTY 8

Locate the Floor Blocks (No. 32) between the floor framing, ensuring they are spaced equally.

Secure to the floor using 2x30mm screws per block, going through the floor OSB and into the floor blocks below.

16x30mm screws



IMPORTANT: Pre-drill before fixing screws.

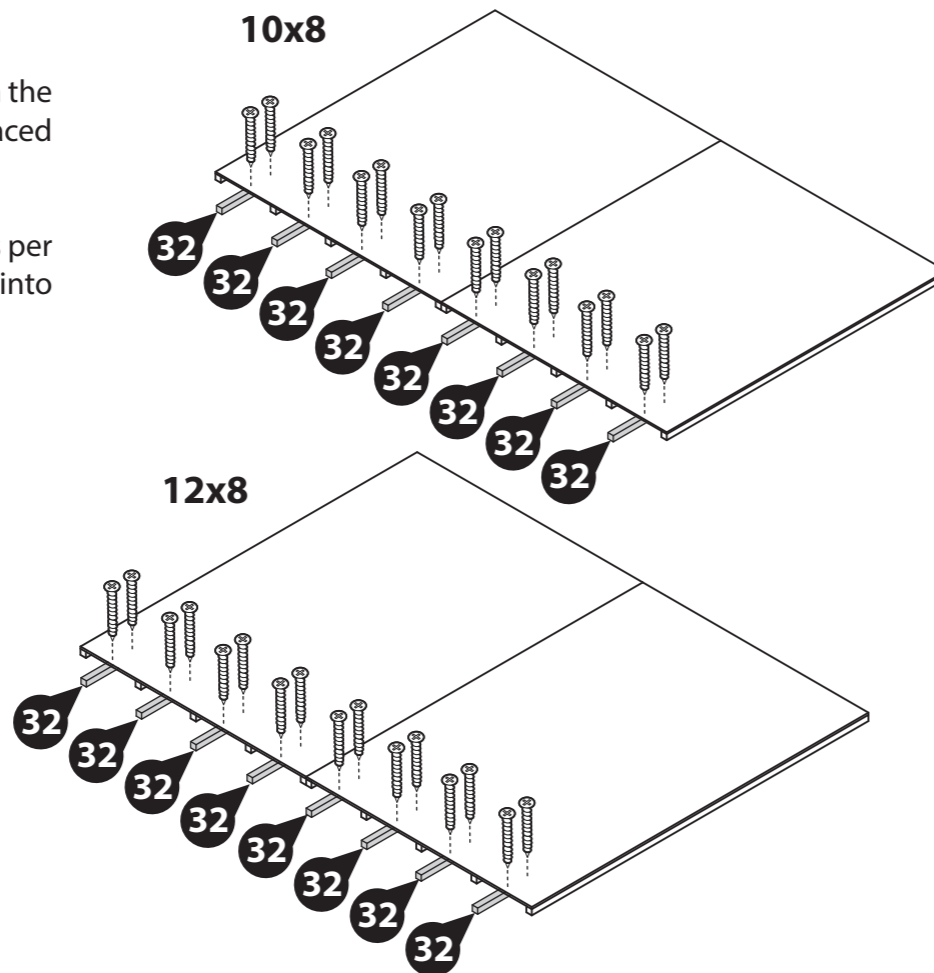

Step 7

Parts Needed - 10x8 - No. 28 QTY 1
Parts Needed - 12x8 - No. 39 QTY 1

****Please note: the Window Panels and Plain Panels are interchangeable and can be positioned on either side of the building. Decide which works best before assembly****

Place the assembled Back Gable Panel and the Plain Panel (**No. 28 or 39**) (or window panel) onto the Floor. Secure the panels together using 4x50mm screws

Do not secure the building to the floor until the roof is fitted.

Position the panels so there is equal spacing between the floor and cladding on all sides

IMPORTANT: Pre-drill before fixing screws.

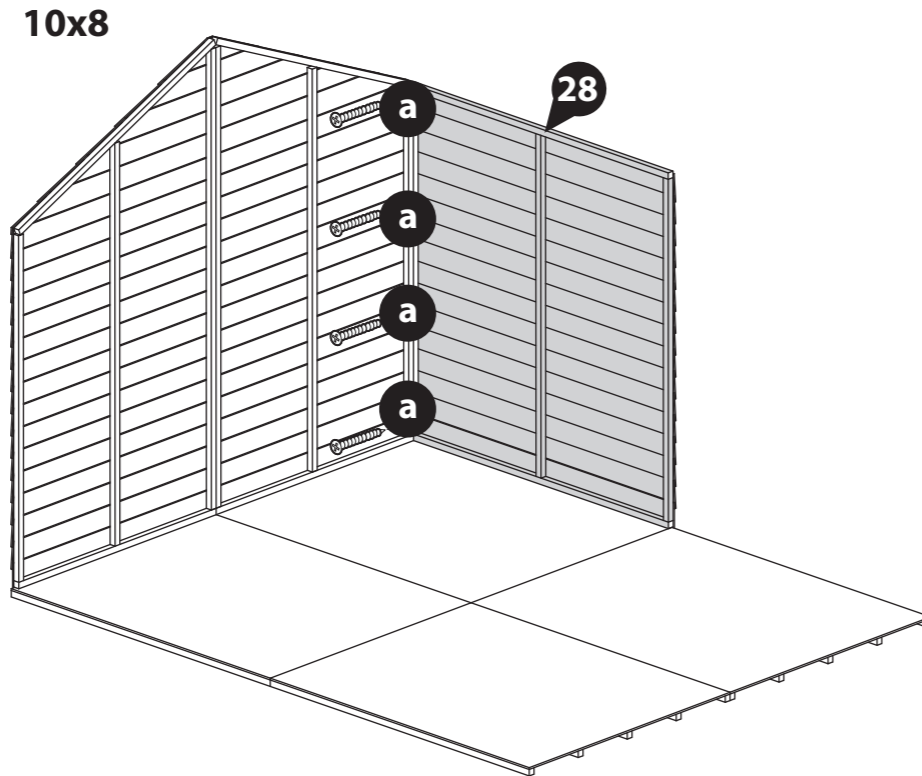

4x50mm screws

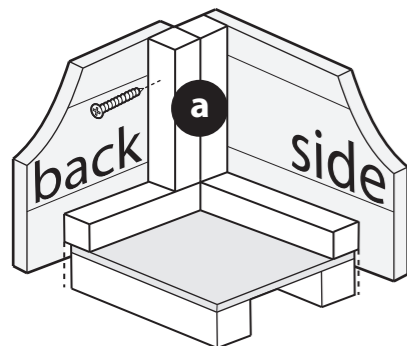
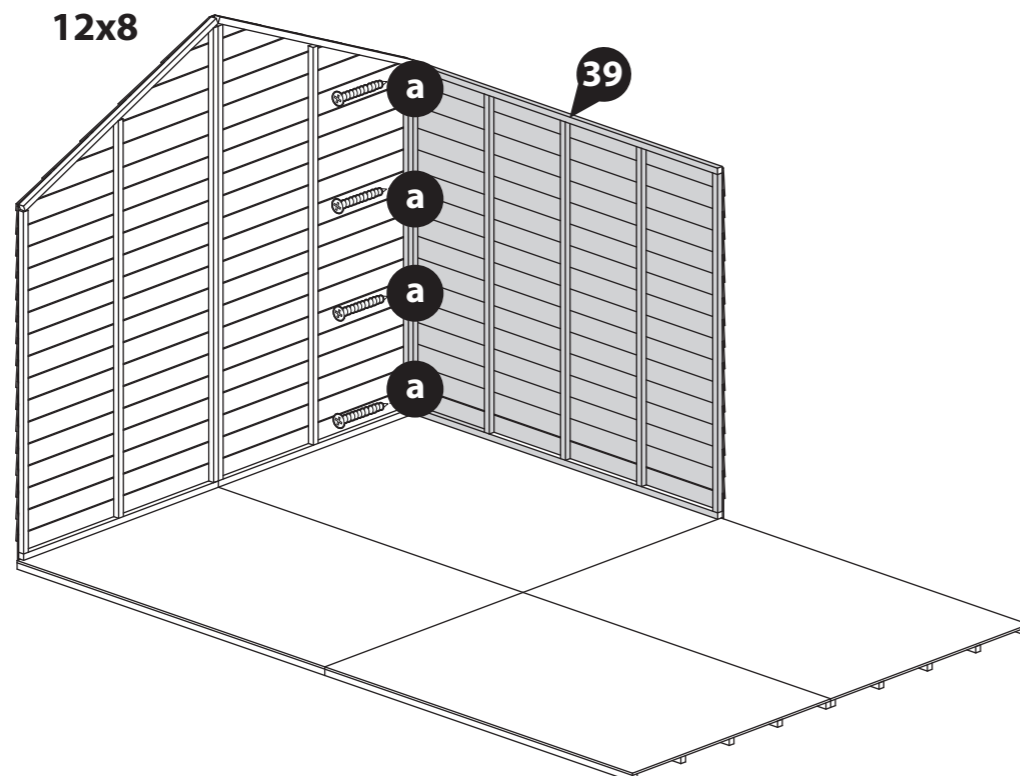
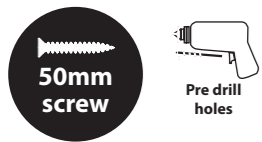

Step 8

Parts Needed 10x8 - No. 26 QTY 1 (Fixed Window Only)
No. 28 QTY 1 (No Window QTY 2)
Parts Needed 12x8 - No. 37 QTY 1 (Fixed Window Only)
No. 39 QTY 1 (No Window QTY 2)

****Please note: the Window Panels and Plain Panels are interchangeable and can be positioned on either side of the building. Decide which works best before assembly****

Place another Plain Panel (**No. 28 or 39**) next to the previously placed Plain Panel and fix in place at the join using 4x50mm screws in an alternating pattern.

Place either a Window Panel (**No. 26 or 37**) or another Plain Panel (**No. 28 or 39**) onto the floor on the opposite side of the building and fix in place at the corners using 4x50mm screws.

Do not secure the building to the floor until the roof is fitted.

Position the panels so there is equal spacing between the floor and cladding on all sides

IMPORTANT: Pre-drill before fixing screws.

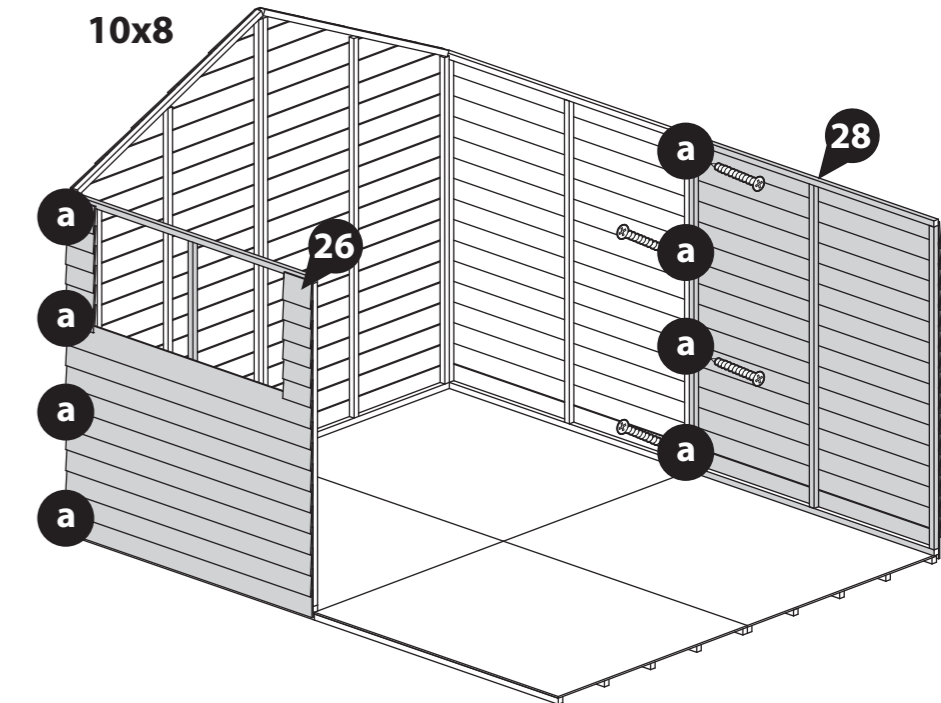

8x50mm screws

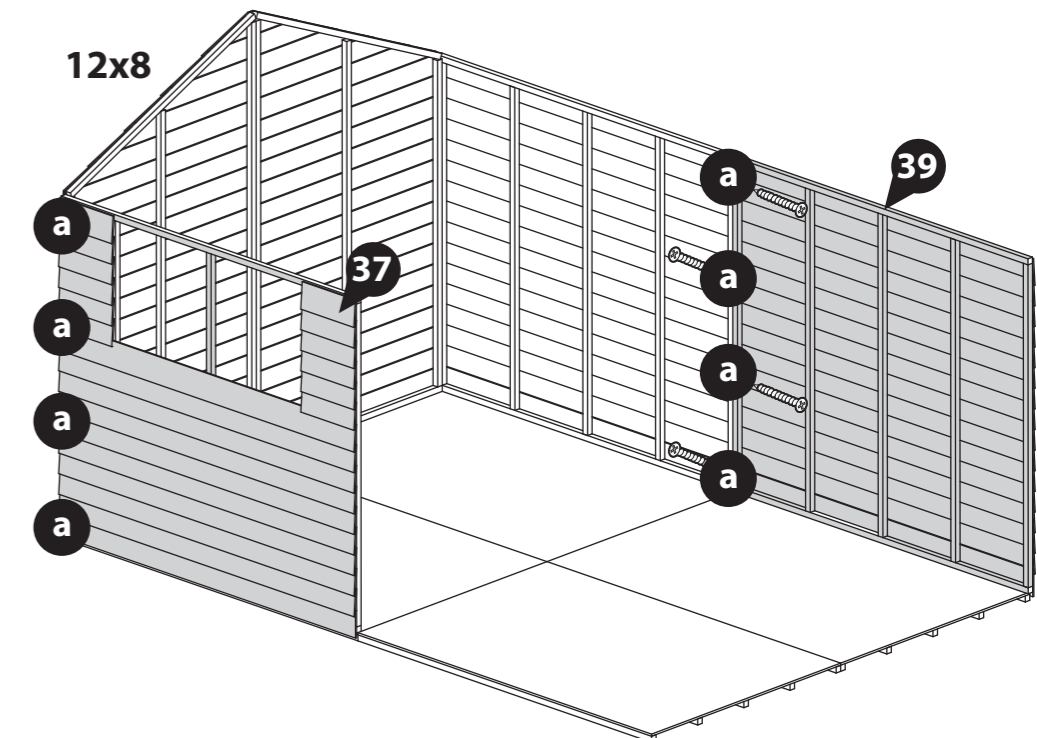
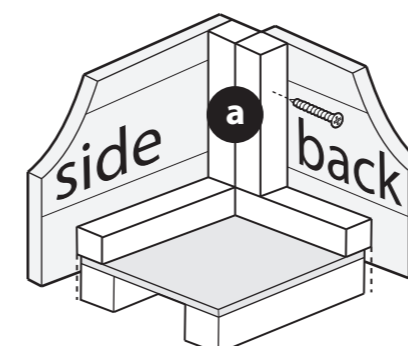
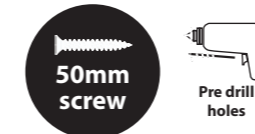

Step 9

Parts Needed 10x8 - No. 26 QTY 1 (Fixed Window)
 No. 28 QTY 1 (No Window)
 Parts Needed 12x8 - No. 37 QTY 1 (Fixed Window)
 No. 39 QTY 1 (No Window)

****Please note: the Window Panels and Plain Panels are interchangeable and can be positioned on either side of the building. Decide which works best before assembly****

Place the remaining Plain/Window Panel (No. 26/No. 28/No. 37/No. 39) onto the floor and fix in place at the join using 4x50mm screws.

Do not secure the building to the floor until the roof is fitted.

Position the panels so there is equal spacing between the floor and cladding on all sides

4x50mm screws

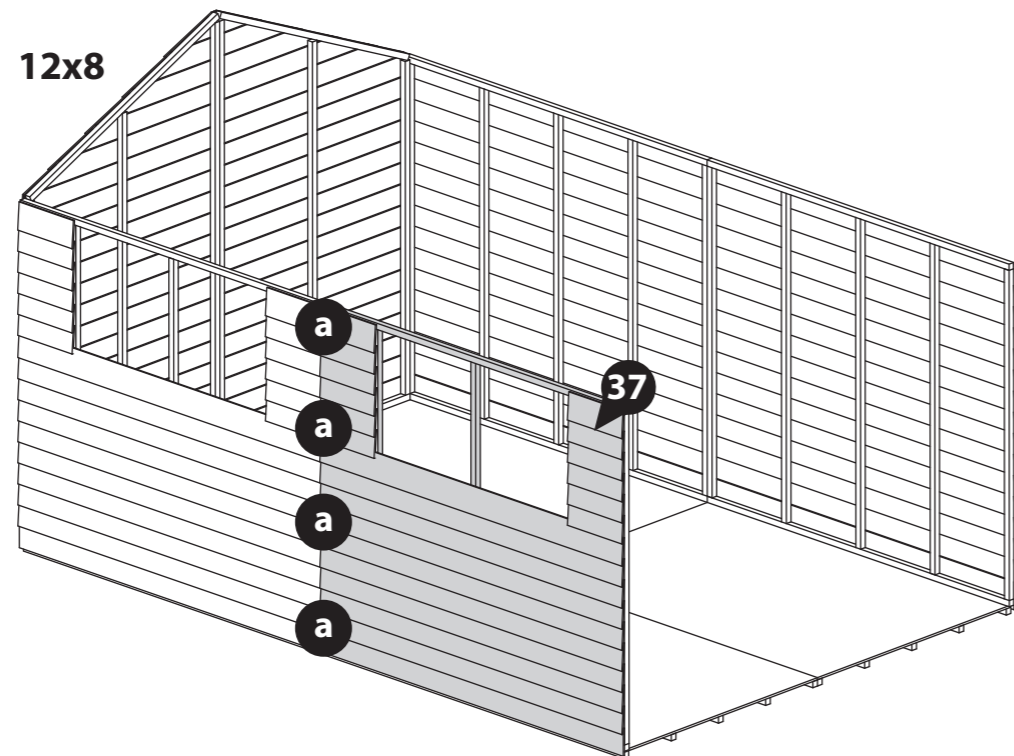
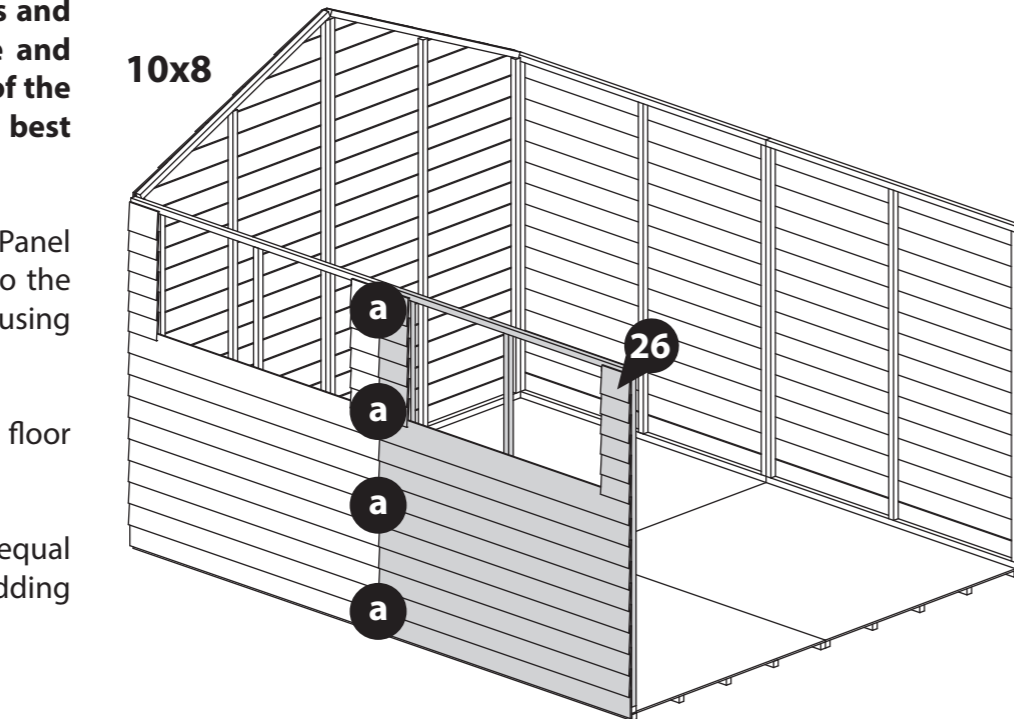
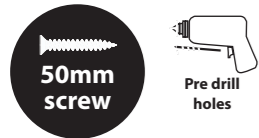

IMPORTANT: Pre-drill before fixing screws.

Step 10

Place the assembled Front Gable onto the building floor, secure the front gable to the side panels using 8x50mm screws at each corner

8x50mm screws

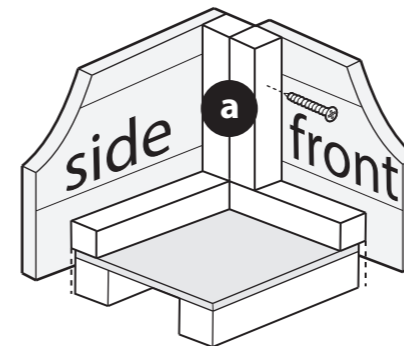

IMPORTANT: Pre-drill before fixing screws.

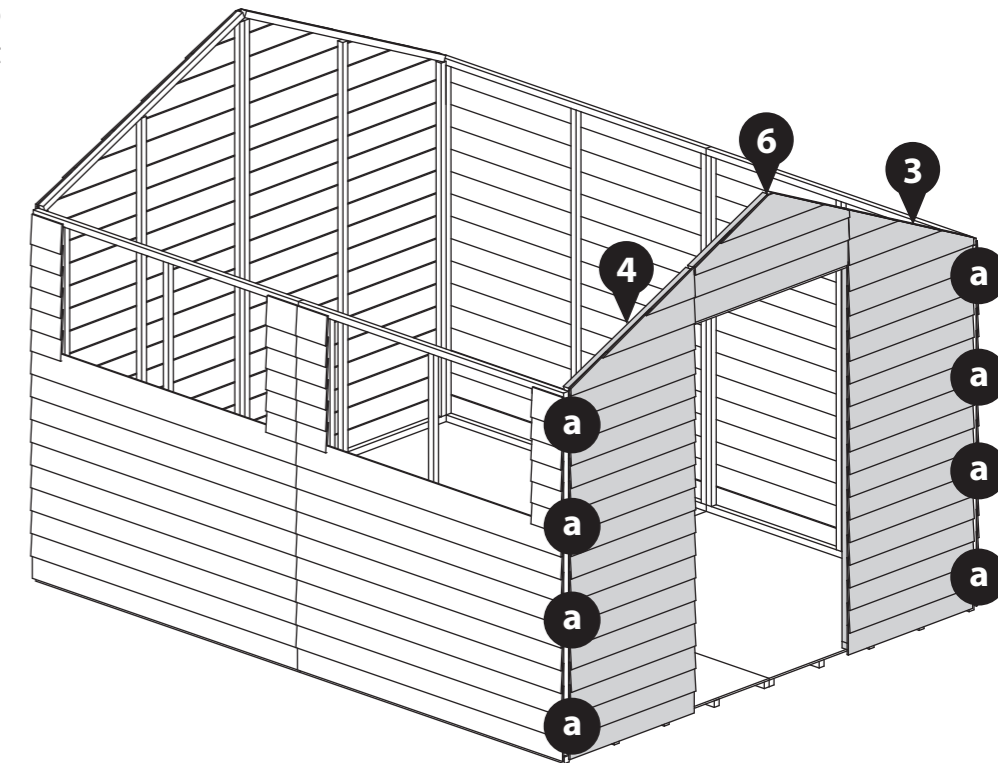

Step 11

Parts Needed - No. 18 QTY 1

Fit the Door Framing (No. 18) between the Front Gable Left and Right.

Fix to the floor using 3x50mm screws, making sure the screws go through to the floor framing.

3x50mm screws



IMPORTANT: Pre-drill before fixing screws.

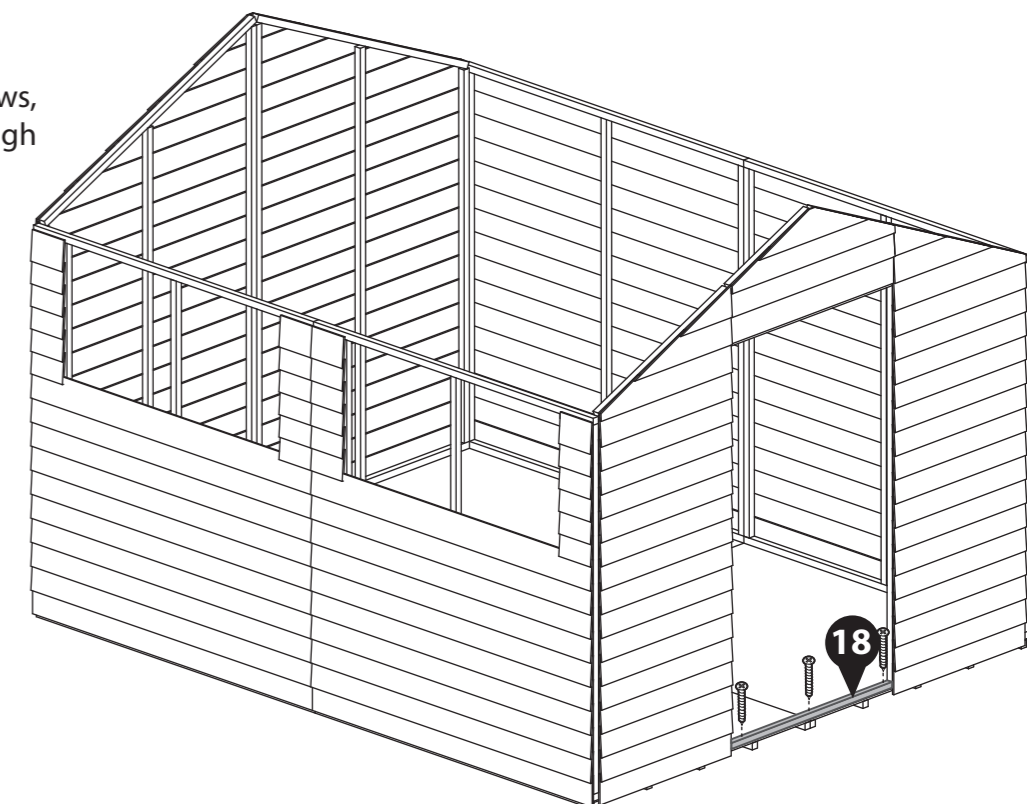

Step 12

Parts Needed - No. 5 QTY 2
No. 8 QTY 4

Fix the T Hinges (No. 8) onto the doors (No. 5) and door gable using 7x30mm screws per hinge as shown.

Ensure that the screws go through the cladding and into the framing behind.

28x30mm screws

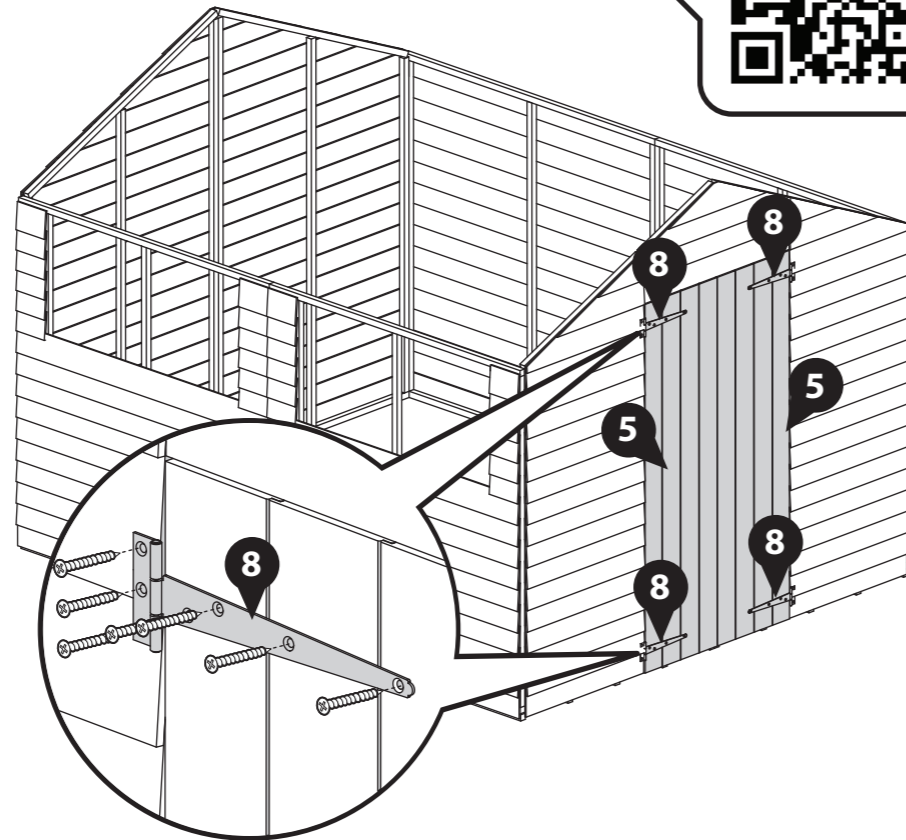
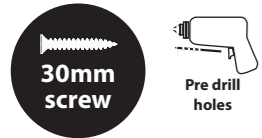

Door Framing Position

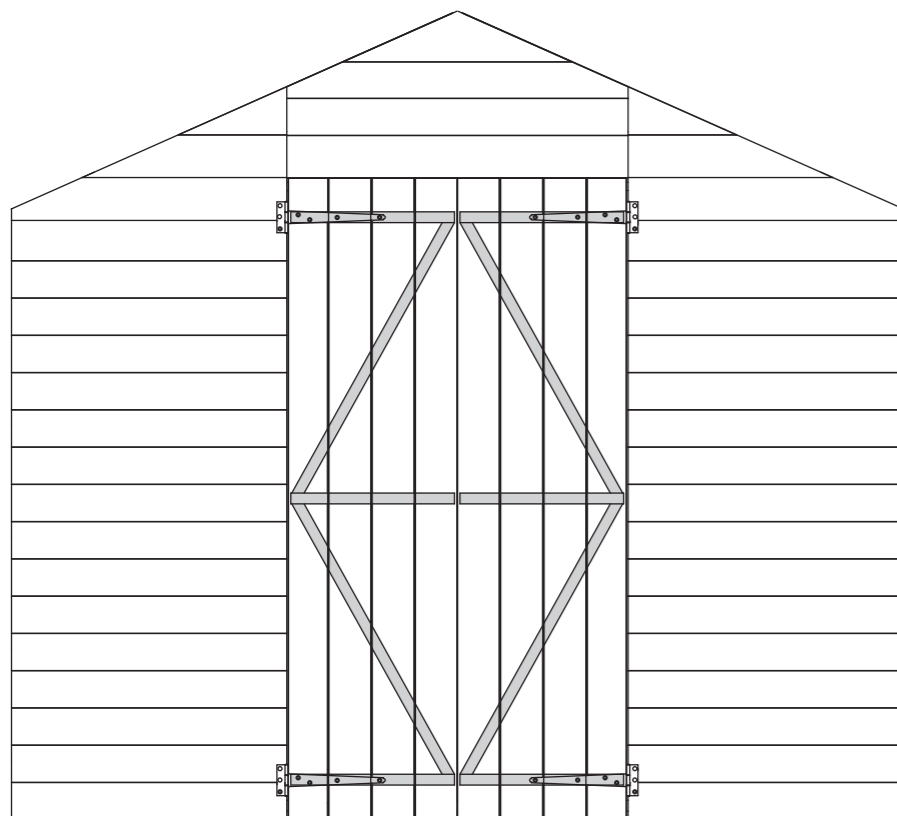

IMPORTANT: Pre-drill before fixing screws.



Step 13

Parts Needed 10x8 - No. 9 QTY 2
No. 11 QTY 1
No. 31 QTY 2

Parts Needed 12x8 - No. 9 QTY 2
No. 11 QTY 1
No. 41 QTY 2

Position the two Ridge Bars (No. 31 or 41) within the U channel (No. 11) Secure using 10x30mm screws.

Secure a corner brace (No. 9) to either end of the ridge bar using 2x30mm screws per brace.

14x30mm screws

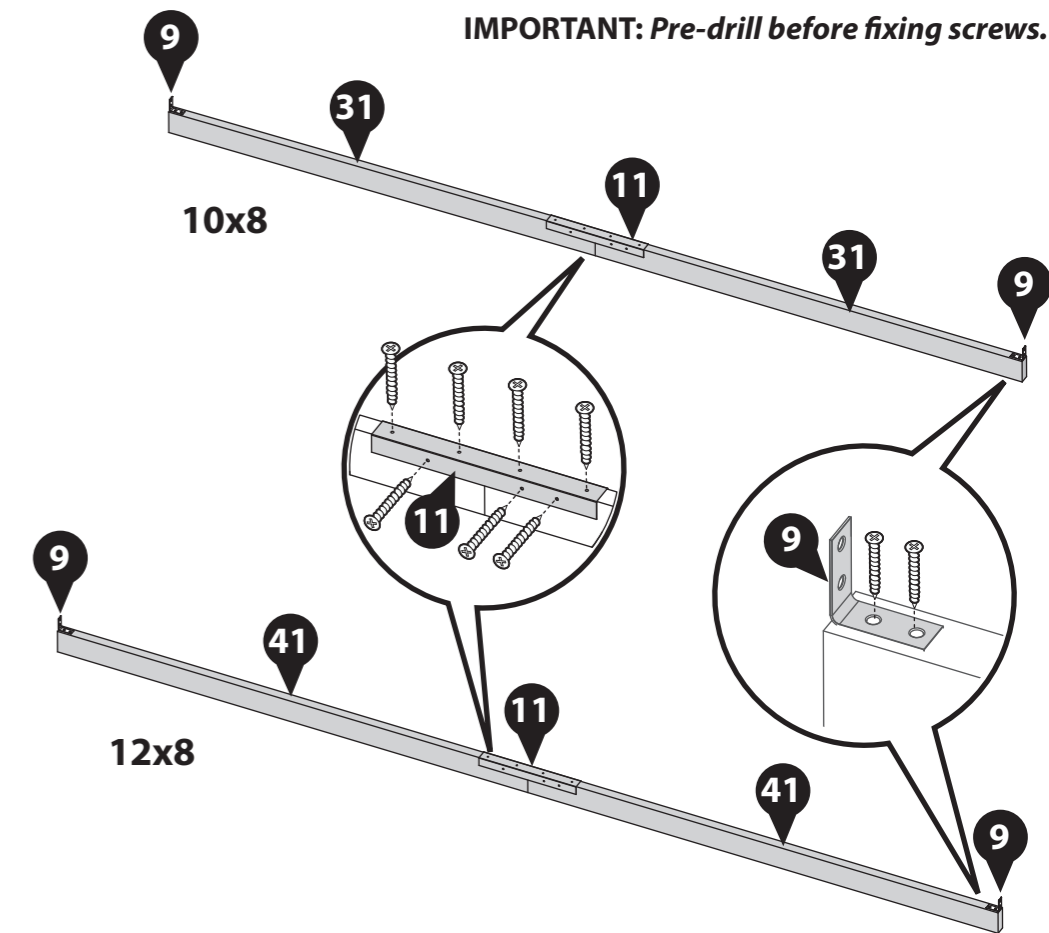
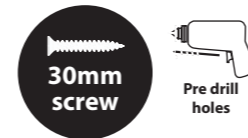

IMPORTANT: Pre-drill before fixing screws.



Step 14

Place the assembled ridge bar in between the front and back Gables. Ensure the top corners of the support bar are flush with each top point of the Gable.

Secure the corner brace (No. 9) onto both the Gables framing using

4x30mm screws

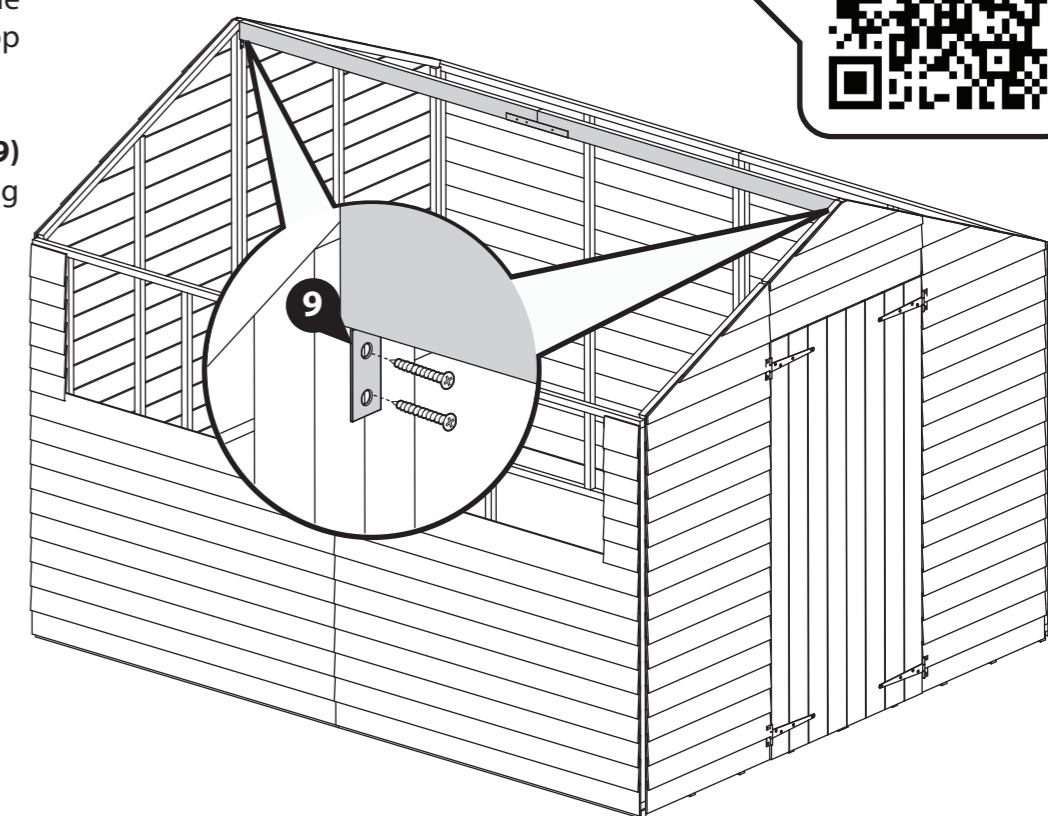

Step 15

Parts Needed 10x8 - No. 29 QTY 8
 - No. 30 QTY 8
 Parts Needed 12x8 - No. 40 QTY 4
 - No. 42 QTY 4

Locate the Roof Eaves (No. 30 or No. 42) to the Bottom of the Roof Sheets (No. 29 or No. 40), ensuring they are flush with the edge of the Roof sheet. Secure using 4x30mm screws (12x8) or 3x30mm screws (10x8) fixing through the Roof sheet and into the roof eaves.

10x8 - 24x30mm screws
 12x8 - 16x30mm screws

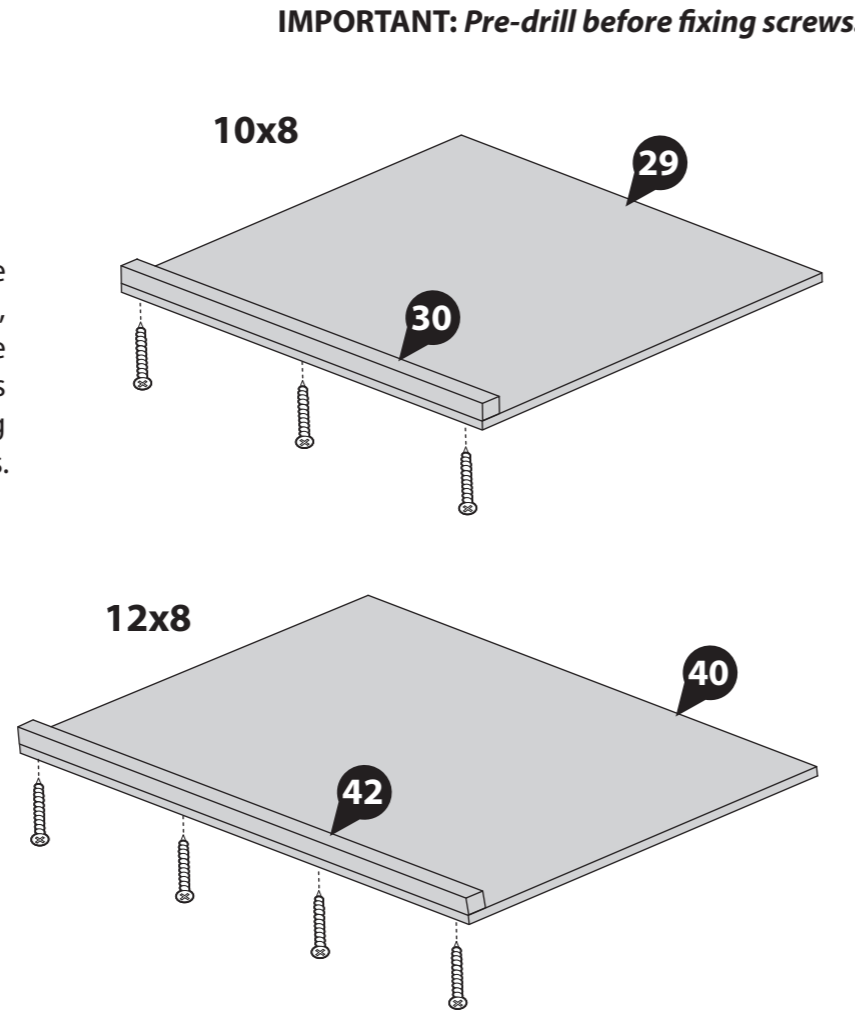
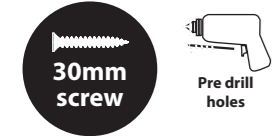

Step 16

Parts Needed 10x8 - No. 29 QTY 8
 Parts Needed 12x8 - No. 40 QTY 4

Place the Roof sheets (No. 29 or No. 40) on top of the building. From the top, fix directly through the roof sheet and into the ridge bar below using 3x50mm screws (10x8) or 4x50mm screws (12x8) per roof panel.

Note: You may require another person pushing the ridge bar up from below to achieve this.

10x8 - 24x50mm screws
 12x8 - 16x50mm screws

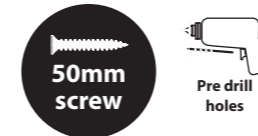

IMPORTANT: Pre-drill before fixing screws.

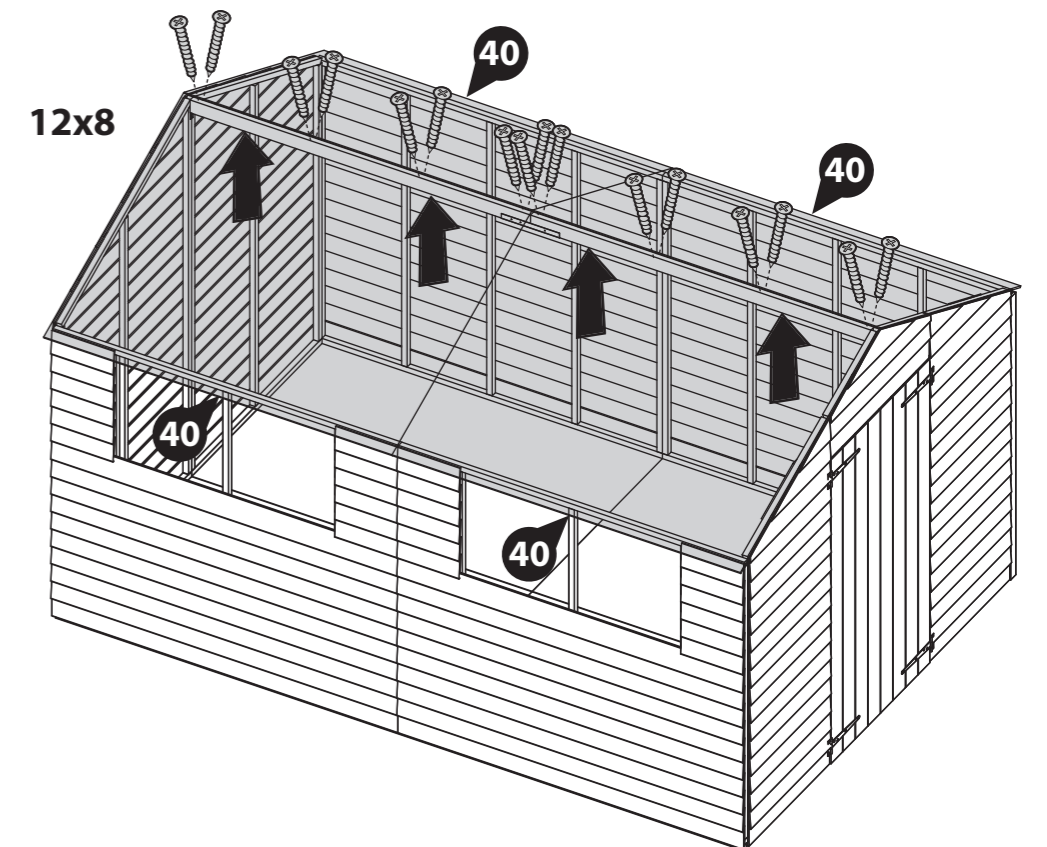
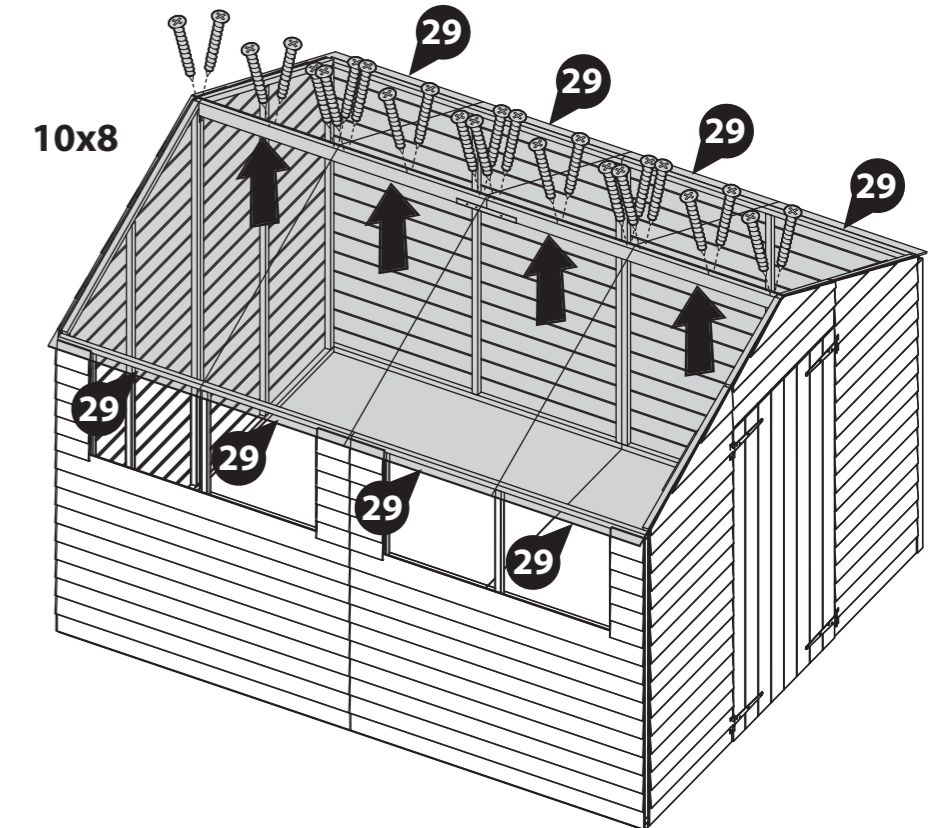

Step 17

Parts Needed - No. 17 QTY 6

Position the Truss Framing (No. 17), centrally underneath the joins of the roof panels internally (For the 12x8, position the framing centrally to each roof panel and along the panel joins).

Ensure the Truss Framing (No. 17) sits flush to the underside of the roof panels and flush with the ridge bar as shown in the illustration.

Fix the Truss Framing (No. 17) in place using 4x30mm screws per roof sheet, fixing through the roof sheets into the Truss Framing from the outside of the building.

***Where Truss framing lays below the roof joins, alternate 8x30mm screws through each roof panel for a more secure hold.**

10x8 - 48x30mm Screws
12x8 - 32x30mm Screws

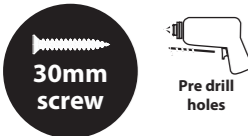

IMPORTANT: Pre-drill before fixing screws.

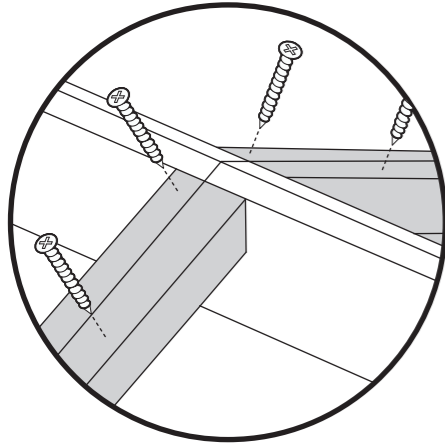
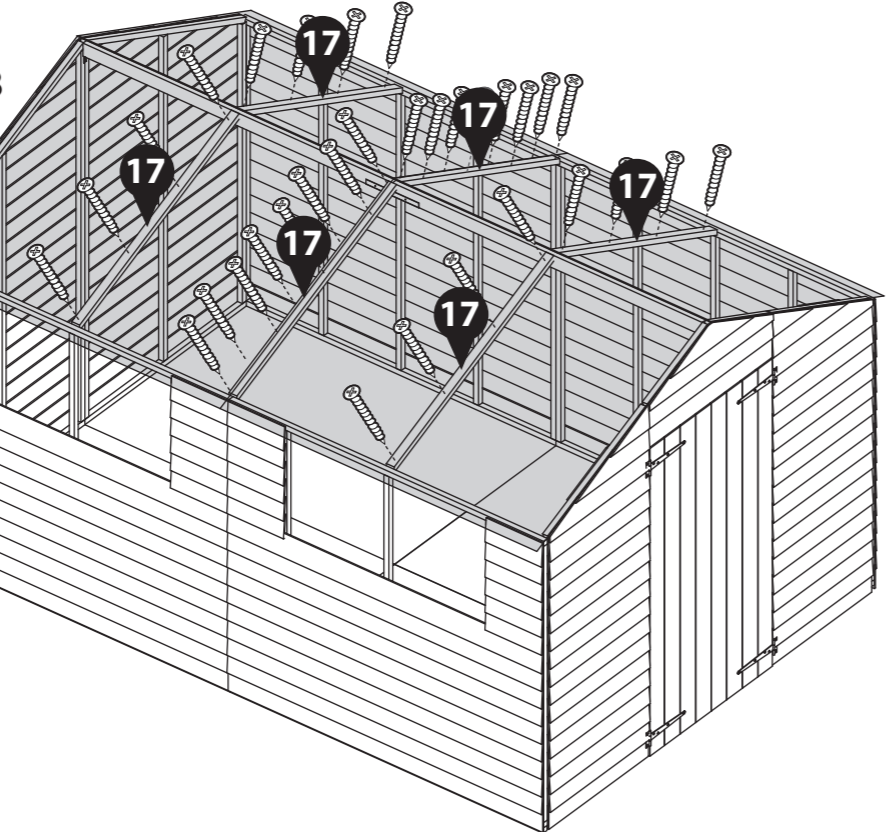
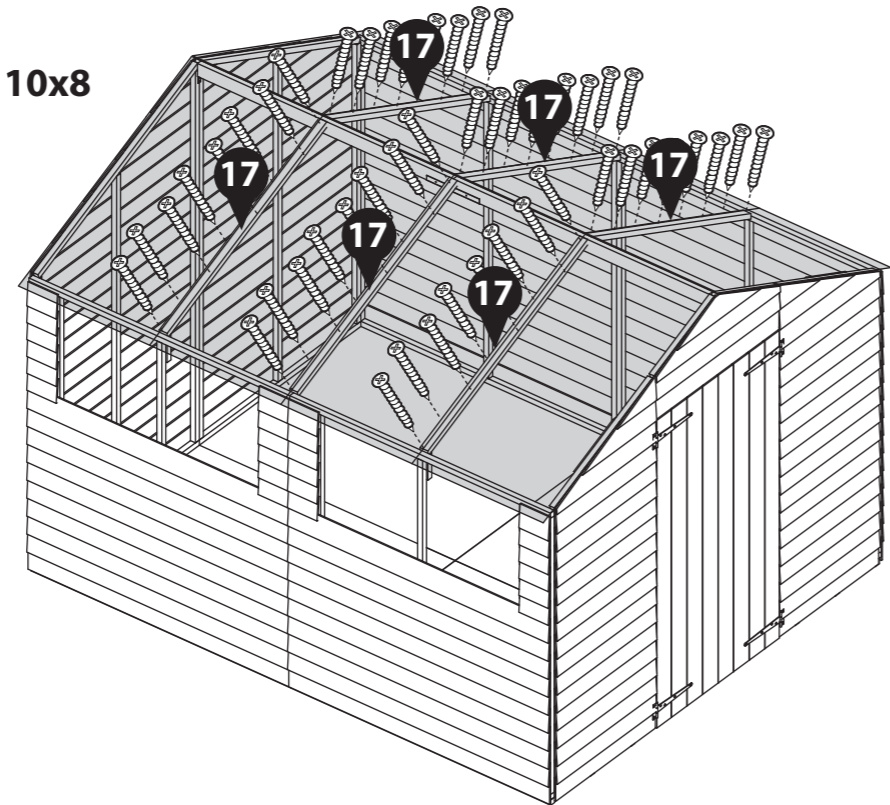

Step 18

Parts Needed - No. 14 QTY 6

Position the truss block (No. 14) at the top of the side panels framing, ensuring the angle is flush to the Truss Frame (No. 17), aligning the block centrally along the join between the side panels.

Fix in place by screwing through the block into the side panel framing using 2x50mm screws.

Repeat for each of the roof truss frames.

12x50mm screws

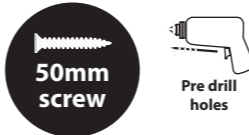

IMPORTANT: Pre-drill before fixing screws.

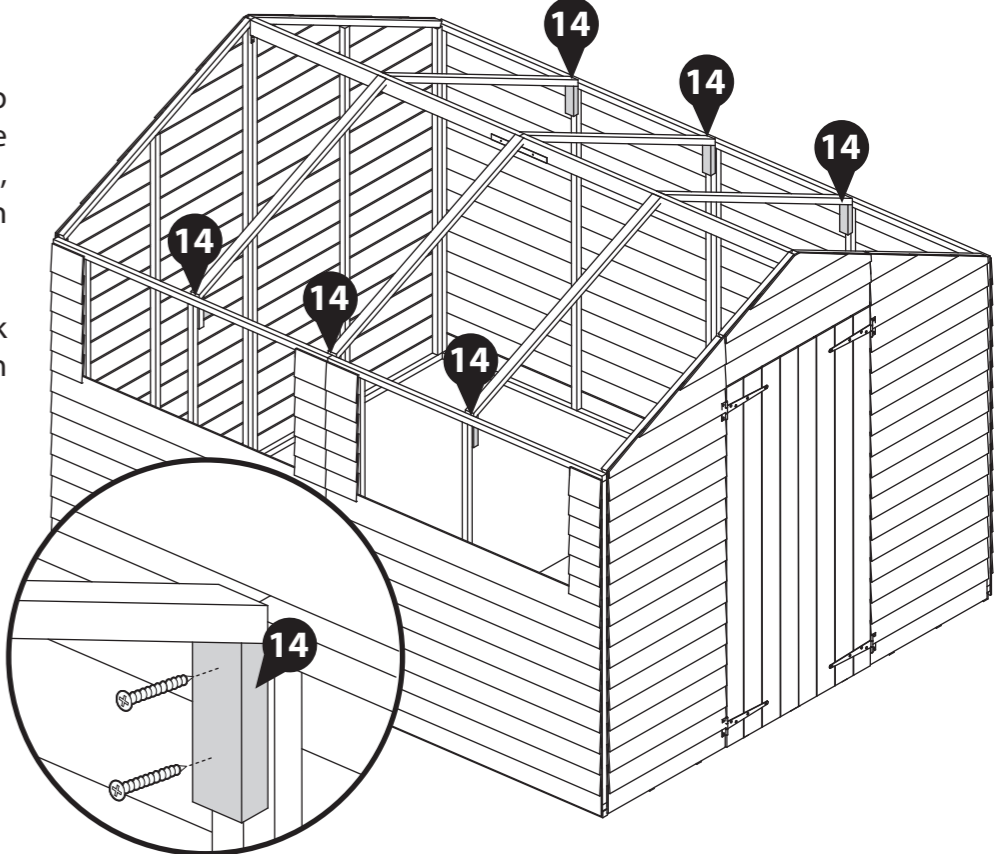

Step 19

Parts Needed - No. 16 QTY 3

Align a Truss support (No. 16) between the two truss frames.

Fix in place by screwing up into the Truss Frames using 2x40mm screws per end, as shown in the illustration.

Repeat for each of the roof truss frames.

12x50mm screws



IMPORTANT: Pre-drill before fixing screws.

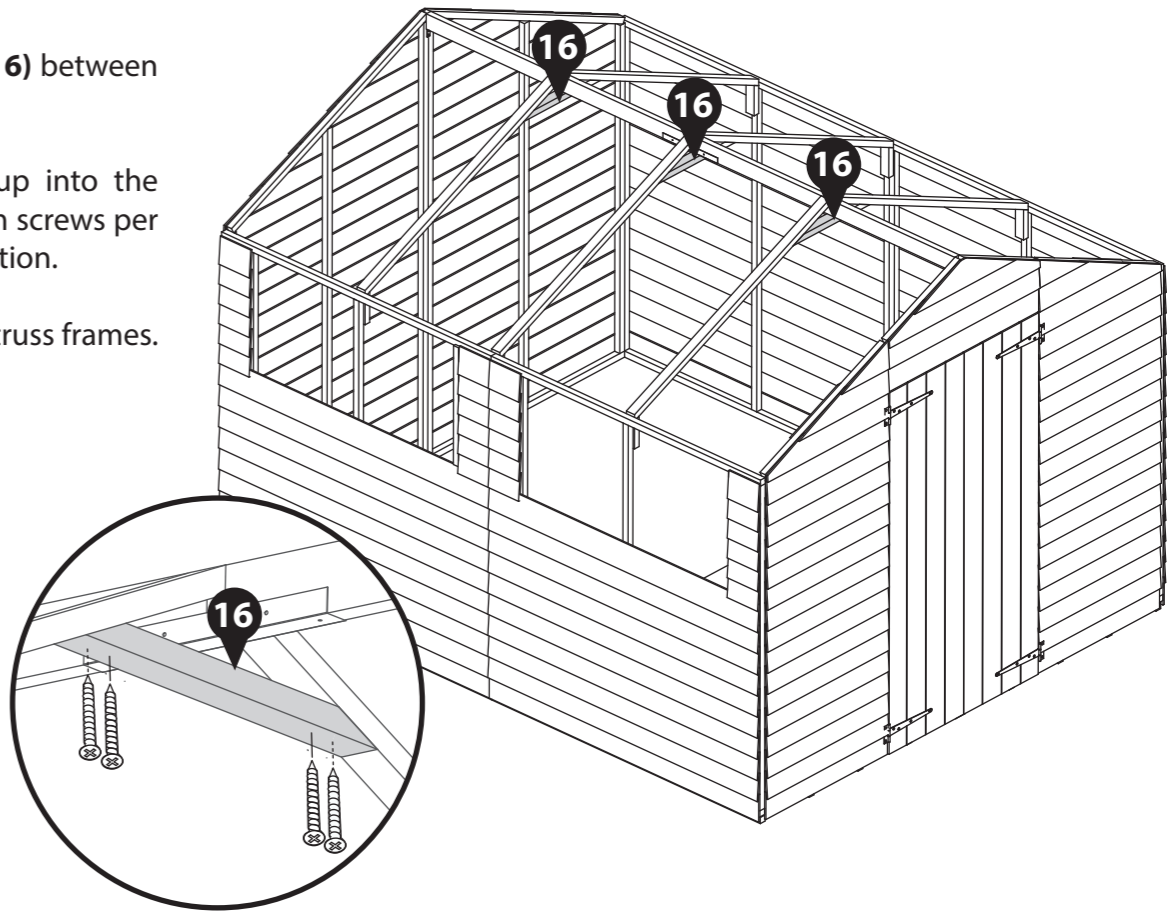

Step 20

Use 40mm screws to fix the roof sheets (**No. 29** or **No. 40**) down the sides and at the bottom, being sure that the screws attach into the framing below.

Ensure there is no more than 300mm between each screw.

10x8 - 36x40mm screws

12x8 - 28x40mm screws

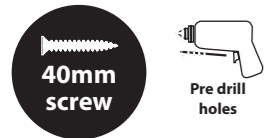

IMPORTANT: Pre-drill before fixing screws.

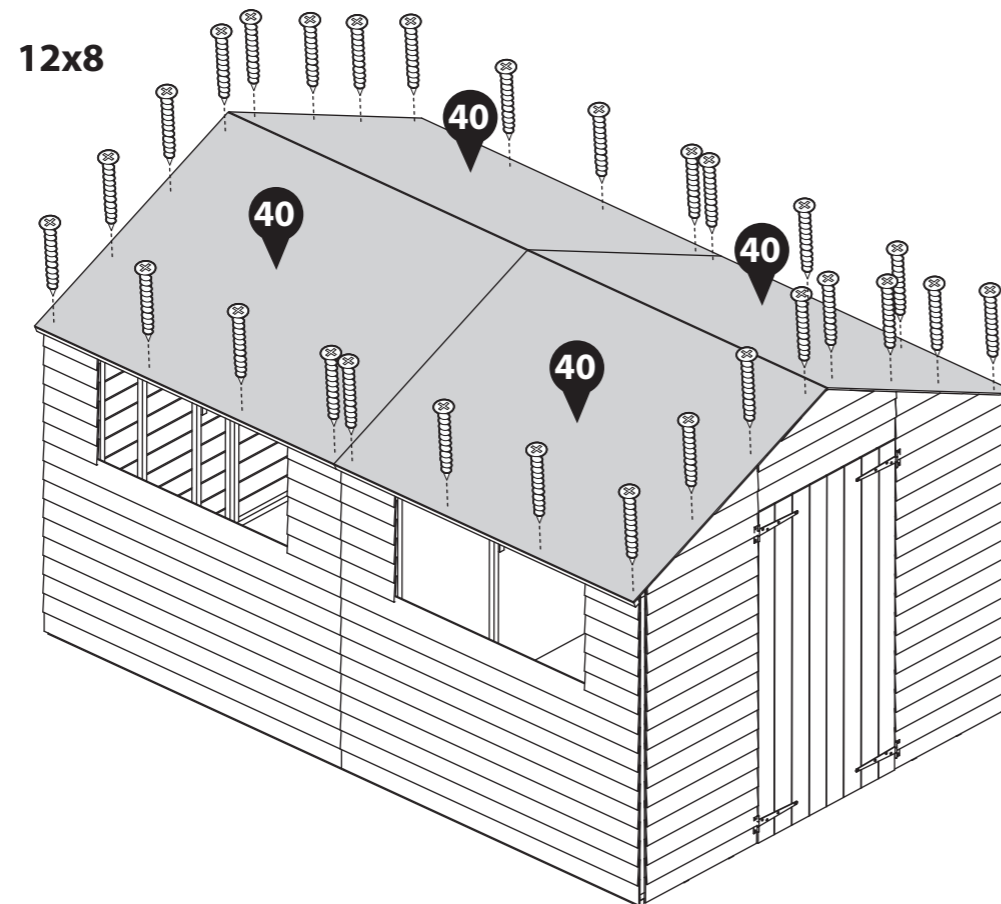
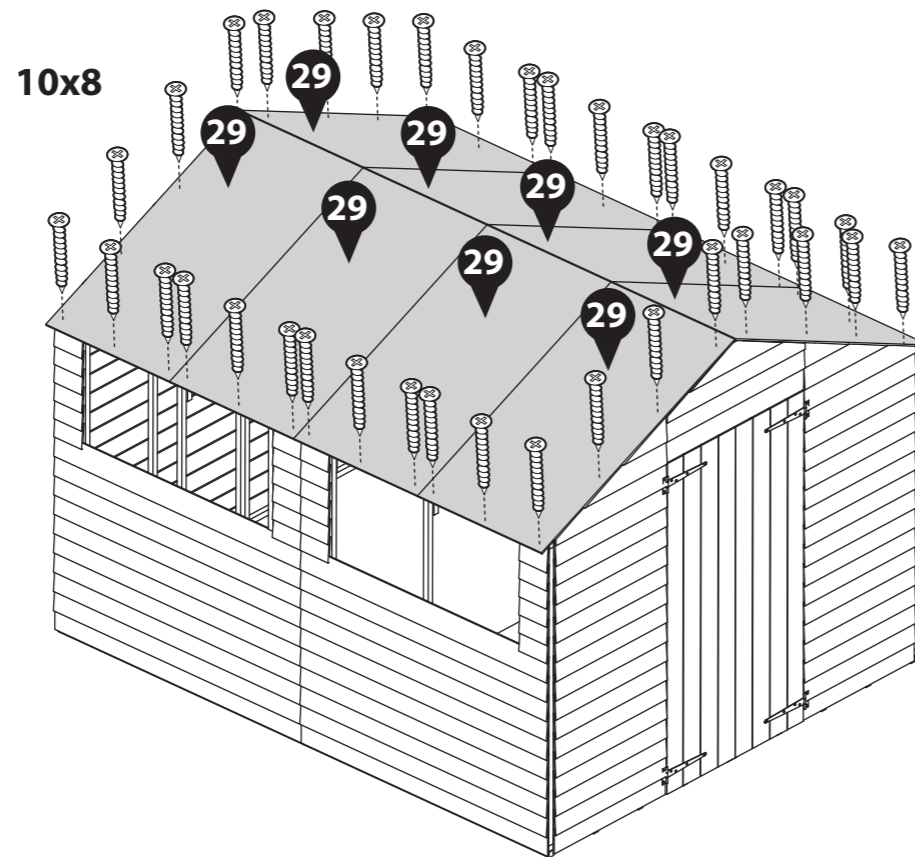

Step 21

Once the roof is fully fixed, attach the panels to the floor using 50mm screws.

Ensure the screws go through the panel into the floor framing.

26x50mm screws

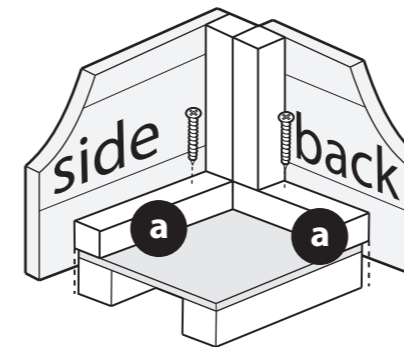
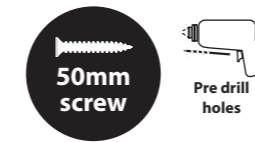

IMPORTANT: Pre-drill before fixing screws.

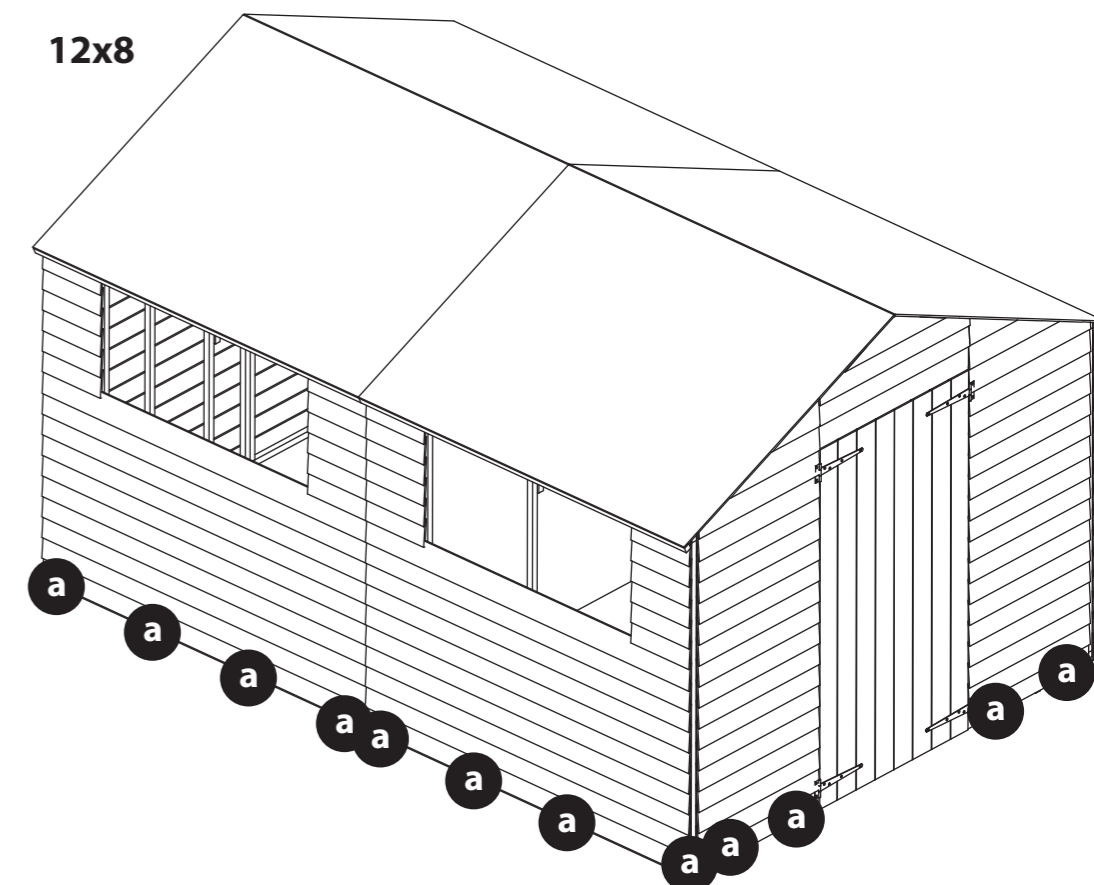
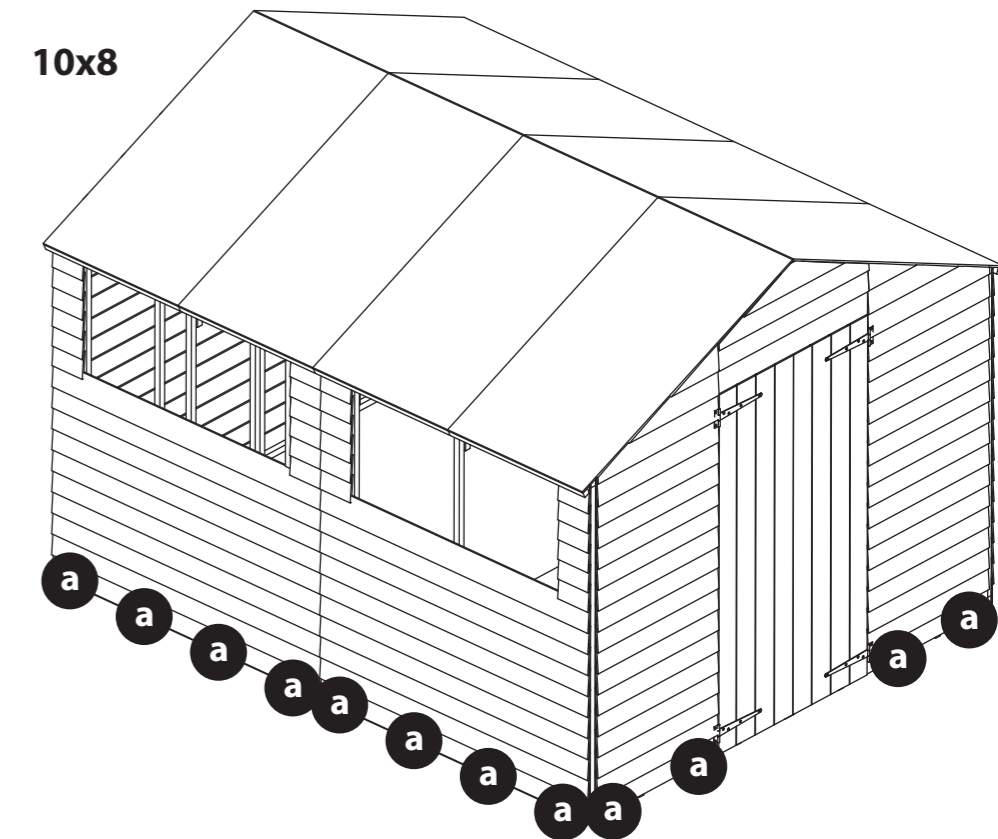

Step 22

Parts Needed - No. 36 QTY 1

Cut the Felt (No. 36) into three strips measuring:

10x8 - 3050mm (L) X 1000mm (W)

12x8 - 3650mm (L) X 1000mm (W)

Lay the Felt flat onto the roof in the order that is stated on the diagram below.

**Ensure there is approximately 50mm of overhang on each side.*

Once the sheets are laid out, fix them onto the roof with felt tacks spaced 100mm apart.

10x8 - 130 x Felt Tacks

12x8 - 150 x Felt Tacks

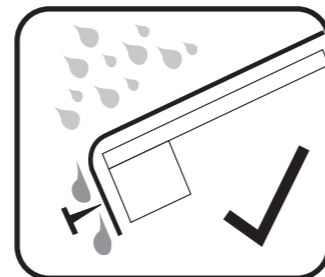
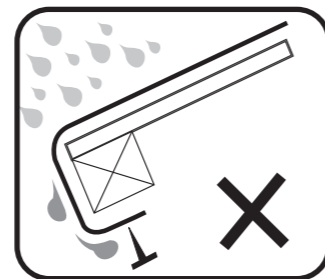
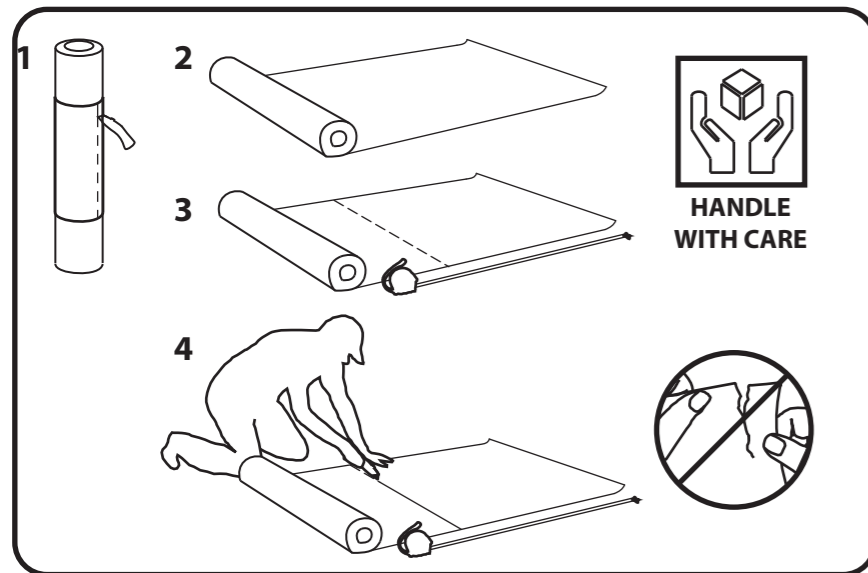
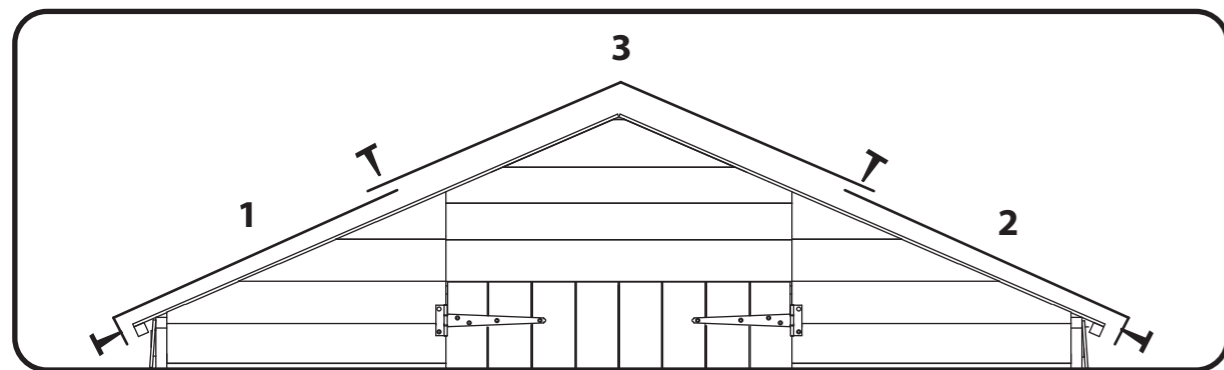
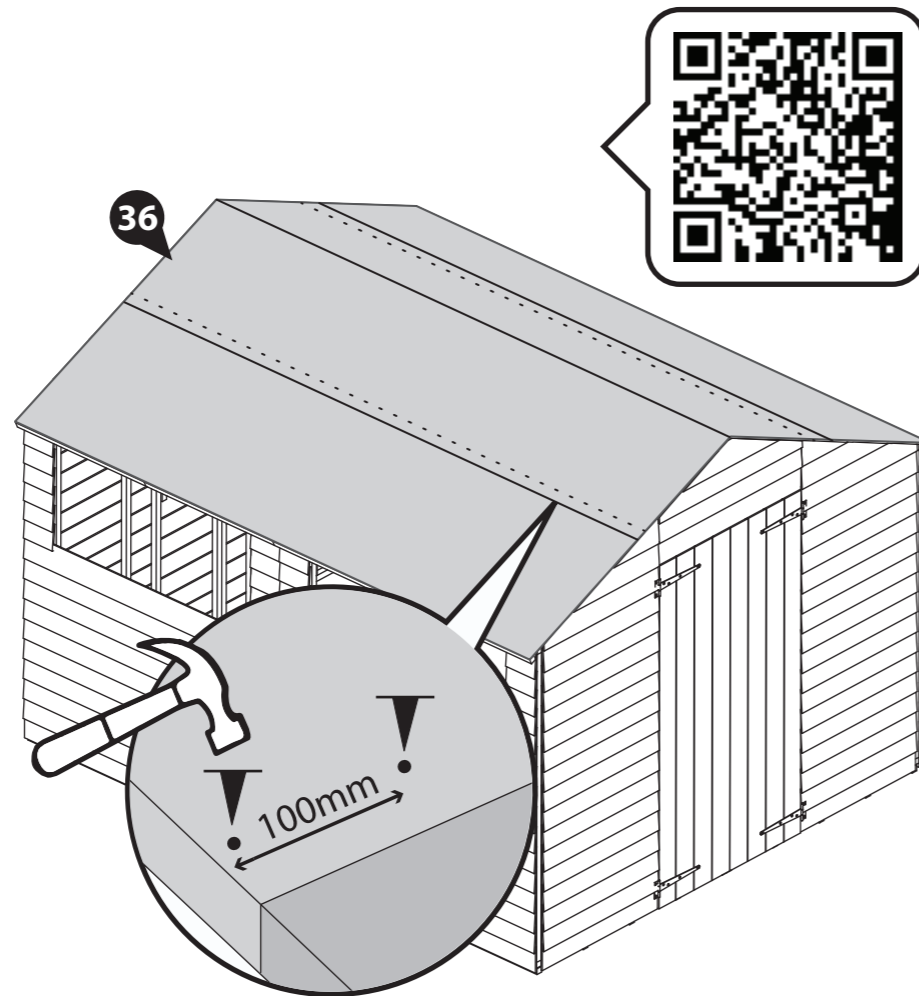

Step 23

Parts Needed - No. 20 QTY 6

Place the panel cover trims (No. 20) onto each corner and panel join of the building, secure using 3x30mm screws per cover trim

18x30mm screws

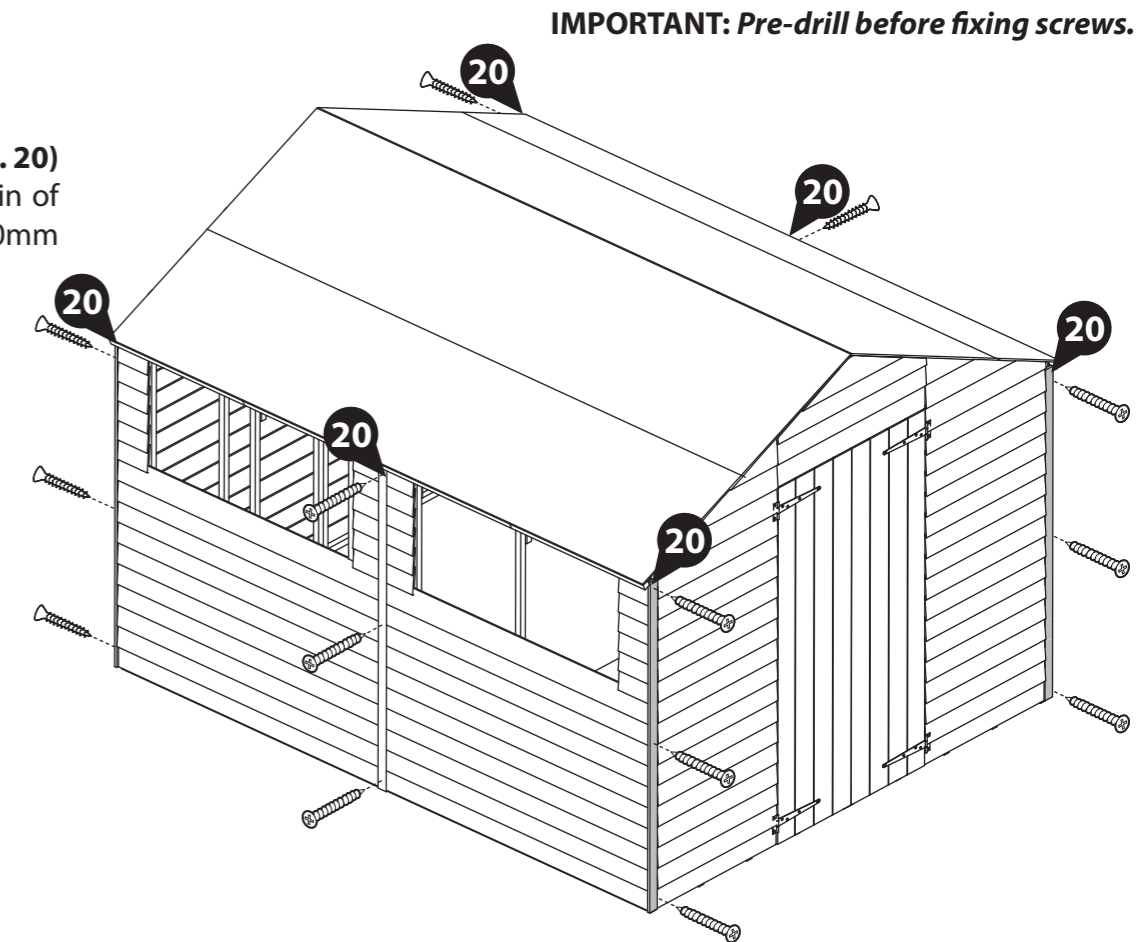

IMPORTANT: Pre-drill before fixing screws.

Step 24

Parts Needed - No. 21 QTY 1

Locate the cover trim (No. 21) on the back of the building. Secure in place using 3x40mm screws.

3x30mm Screws

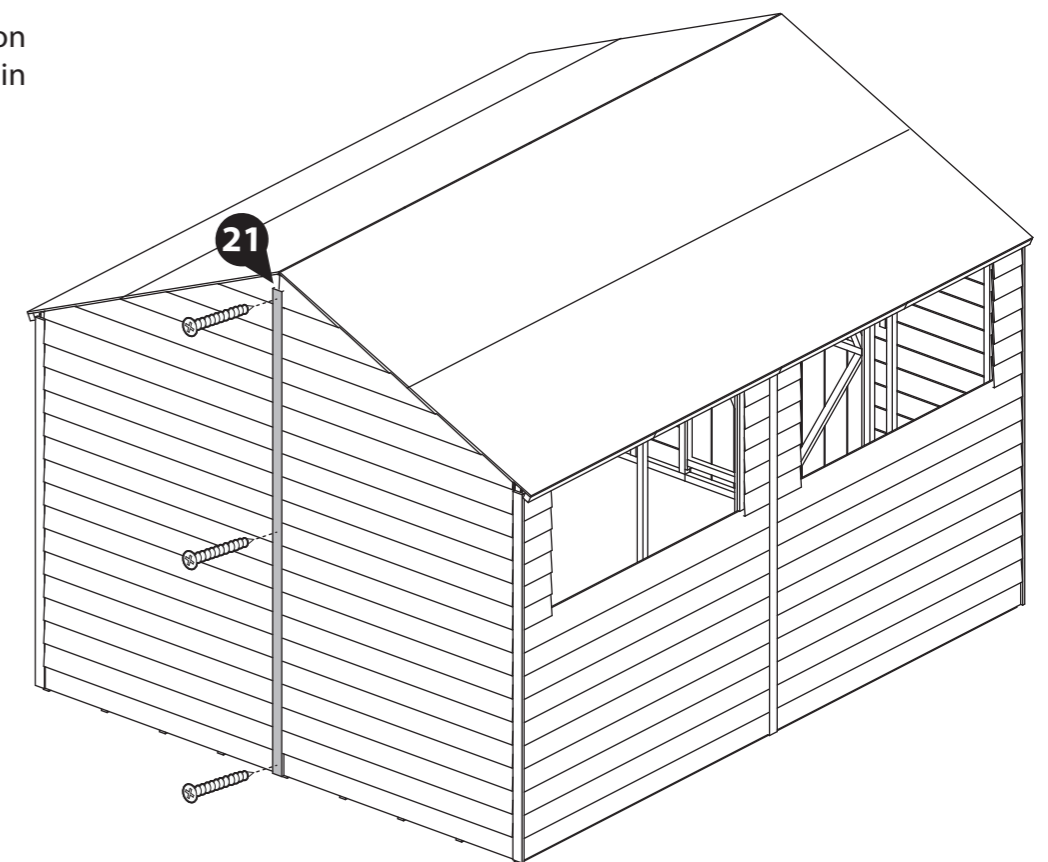

IMPORTANT: Pre-drill before fixing screws.

Step 25

Parts Needed - No. 19 QTY 2

Fit the Front panel Cover strip (No. 19) onto the front gable, so they cover where the panels join together.

Secure in place using 2x30mm screws per cover trim.

4x30mm Screws

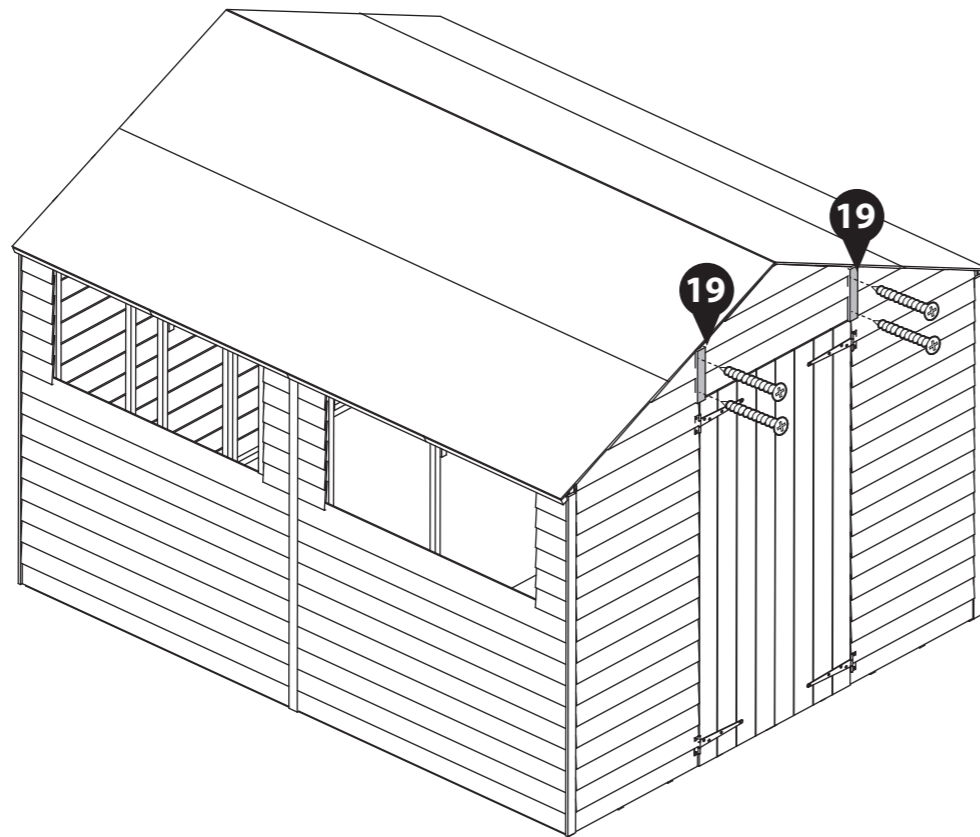
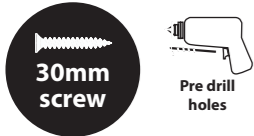

IMPORTANT: Pre-drill before fixing screws.

Step 27

Parts Needed - No. 10 QTY 2

No. 13 QTY 4

No. 25 QTY 2

Place the door blocks (No. 13) next to the internal framing on the top and bottom of the doors and align the ends to the centre.

Fix with 2x30mm screws per block by screwing through the matchboard door into the block.

Locate the Door Beading Strip (No. 25) into the gaps on either side of the doors, between the gables and door.

Fix in place using 4x30mm screws per strip. Ensure that the screw is parallel with the door frame when fixing the strip to the gables as shown in the illustration.

Attach one turn button (No. 10) to the top and bottom door blocks with 1x30mm screw per turn button.

18x30mm screws

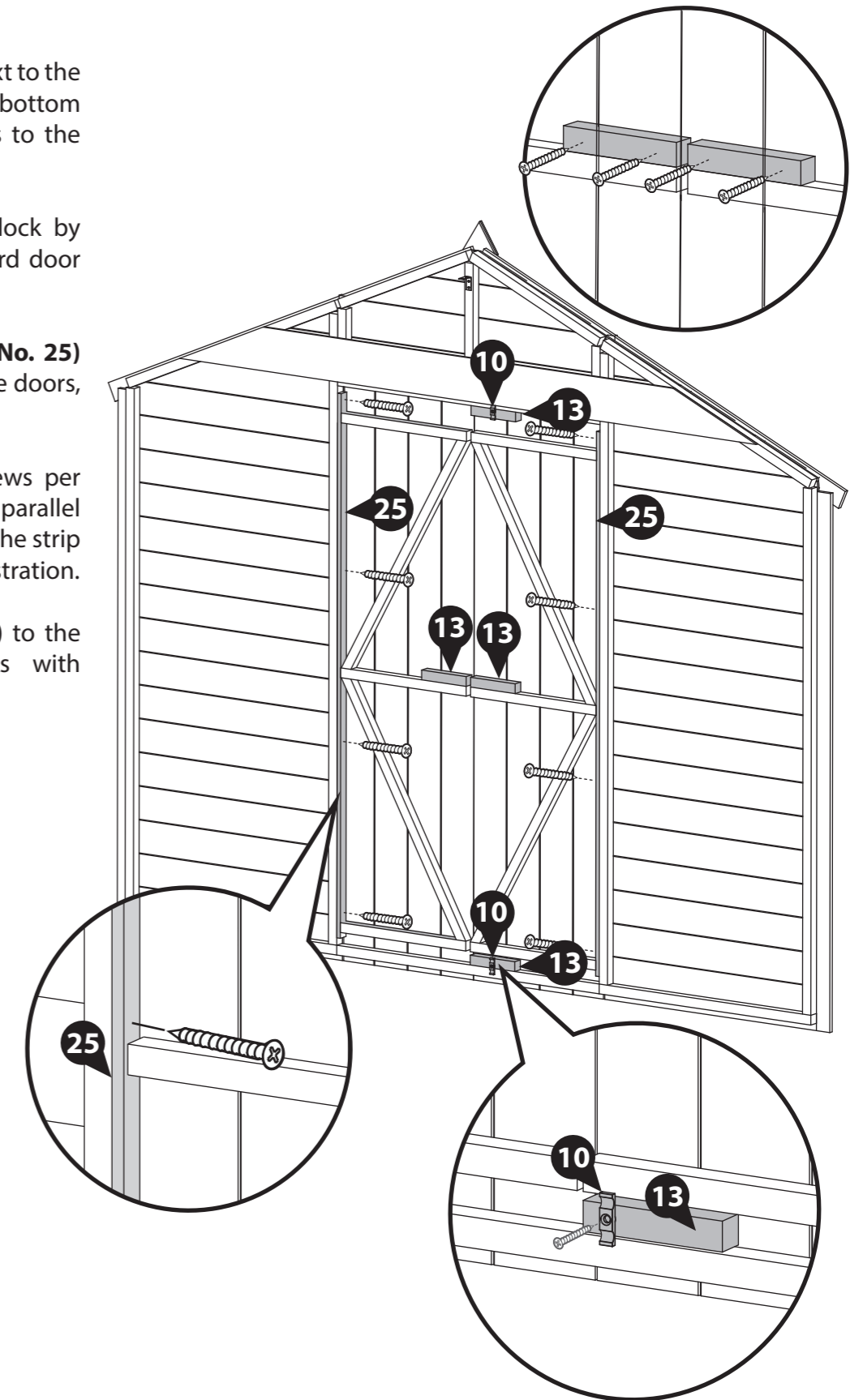
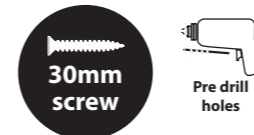

IMPORTANT: Pre-drill before fixing screws.

Step 26

Parts Needed - No. 7 QTY 2

No. 24 QTY 4

Fit the fascias (No. 24) to the roof over the felt and secure into place with 40mm screws as shown. Pre-drill to avoid splitting.

Followed by adding the Finials (No. 7) over the fascias using 2x40mm screws per finial.

16x40mm screws

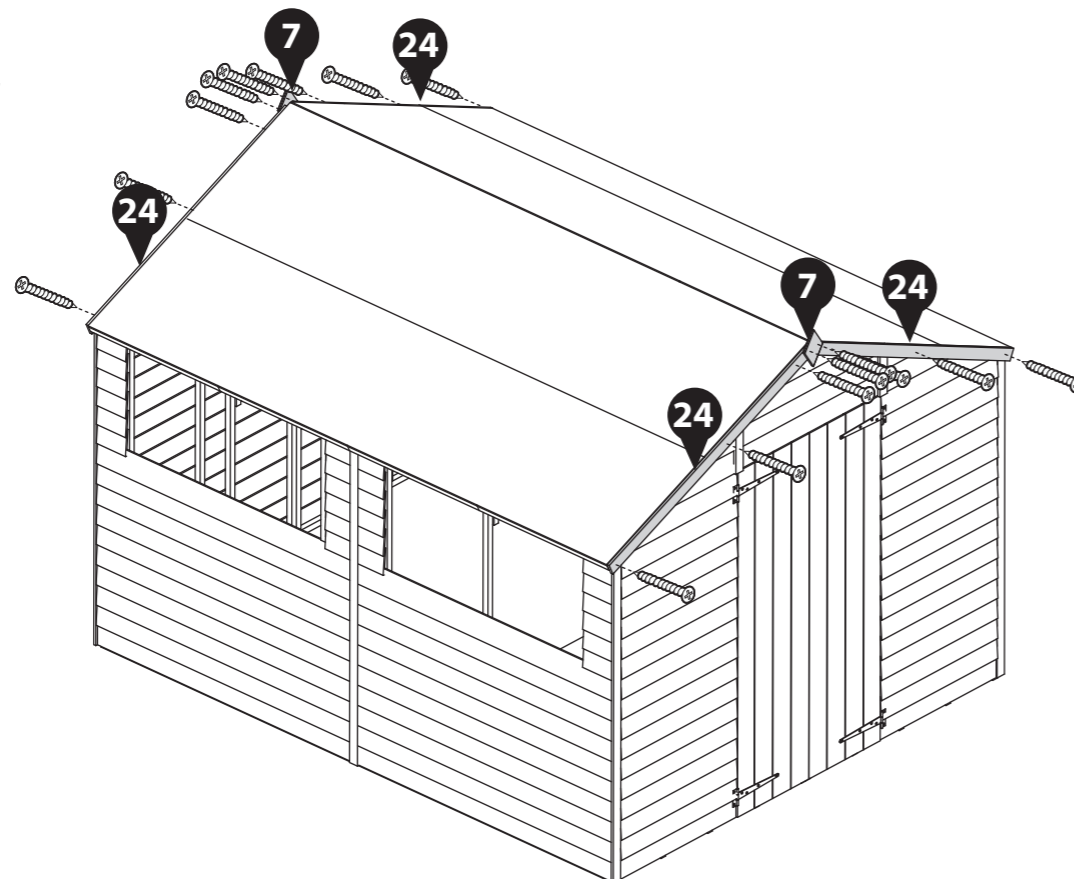

IMPORTANT: Pre-drill before fixing screws.

Step 28

Parts Needed - No. 33 QTY 10
 No. 34 QTY 4
 No. 35 QTY 2

- a** Position two window strips to the internal framing within the window panel opening. Fix using 3x30mm screws per trim.
- b** Place the plastic window cill (No. 35) onto the Window Panel as shown. Fix in place using 3x30mm screws, screwing through the cill into the framing behind.
- c** Fit the styrene sheets (No. 34) on top of the window cill (No. 35), ensuring they are equally spaced in the opening.

**For added weather protection fit your windows using silicone sealant around the outside edges.*

- d** Locate the Window strips (No. 33) onto the Window Panel, one either side of the styrene sheets and one in the centre of the two sheets, as shown.

Fix in place using 3x30mm screws per Trim, ensuring the screws go into the framing of the window panel and not the styrene.

Repeat to fit the windows into both Window Panels.

36x30mm Screws

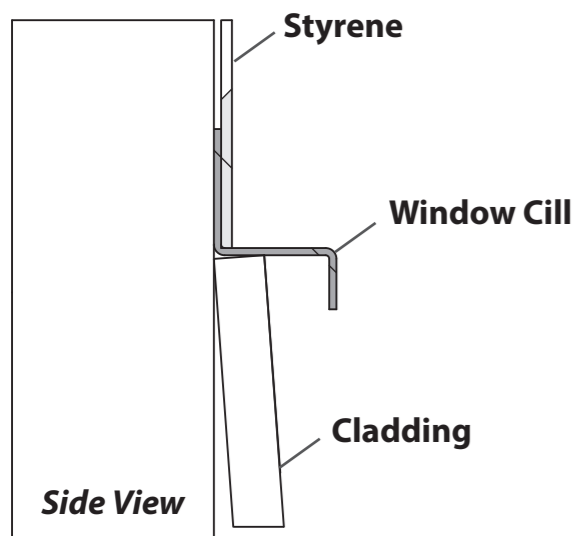
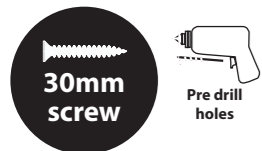

IMPORTANT: Pre-drill before fixing screws.

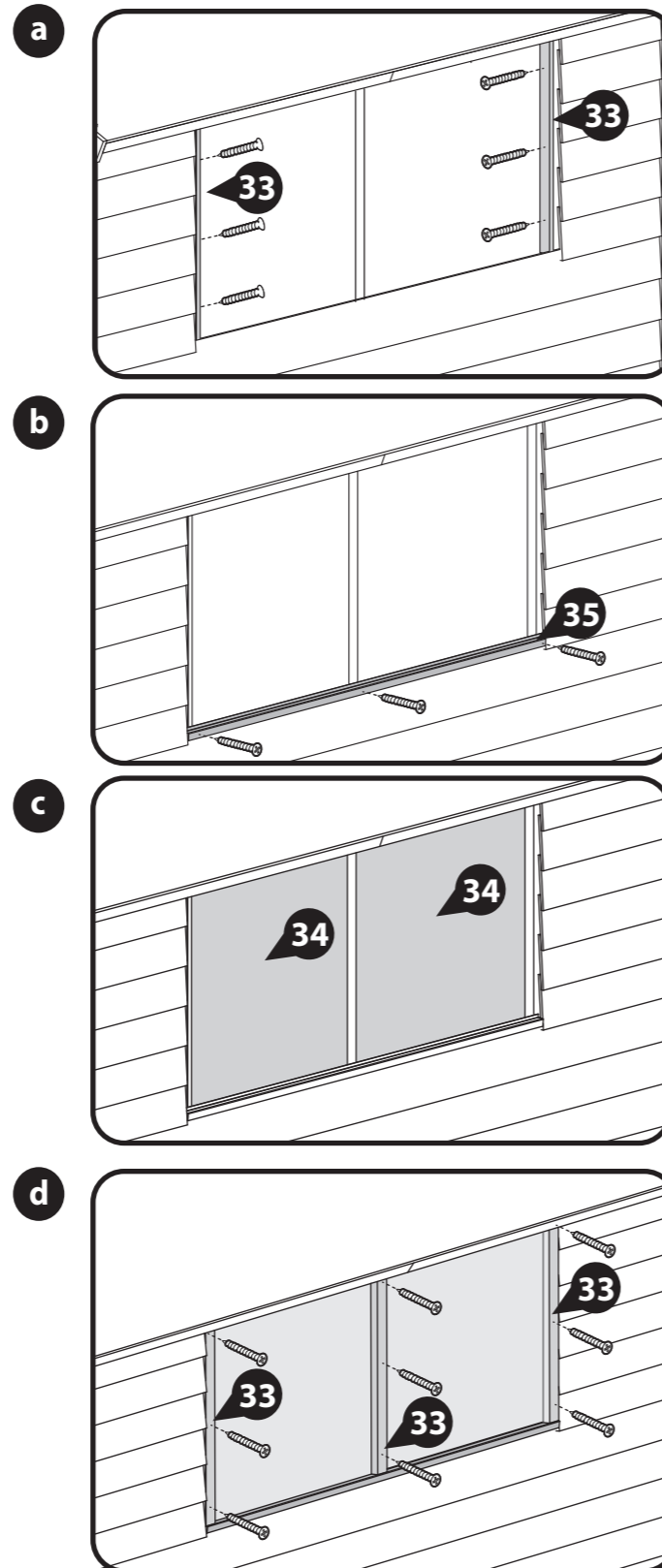

Step 29

Parts Needed - No. 12 QTY 1
 No. 22 QTY 1
 No. 23 QTY 1

Locate the Door cover strips (No. 22 & 23) onto the two doors. Ensure the longer strip (No. 23) is at the bottom, flush with the bottom of the doors, and the shorter strip (No. 22) is at the top, ensuring it is flush to the top of the doors.

Fix the strips to the right hand door using 3x20mm screws per strip.

Fix the Hasp and Staple (No. 12) to the door using 7x30mm screws, ensuring to go through the door cladding and into the door blocks

6x20mm Screws
7x30mm Screws

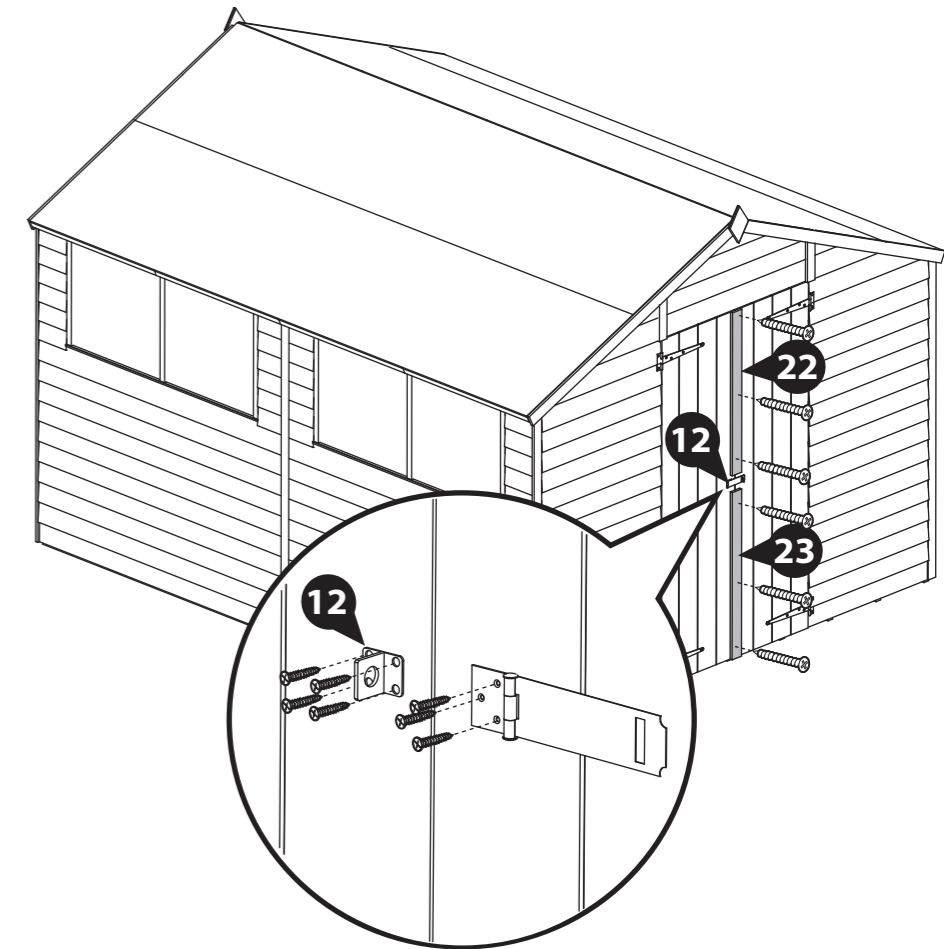
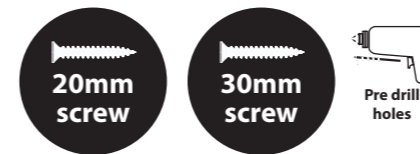

Step 30

Once constructed, apply a preserving treatment and a waterproofing treatment to your garden building as soon as possible. This will help to protect your building and prevent decay.

See page 20 for a full guide and instructions.

Once fully treated, score around the protective covers on the glazing and carefully peel the coverings back.

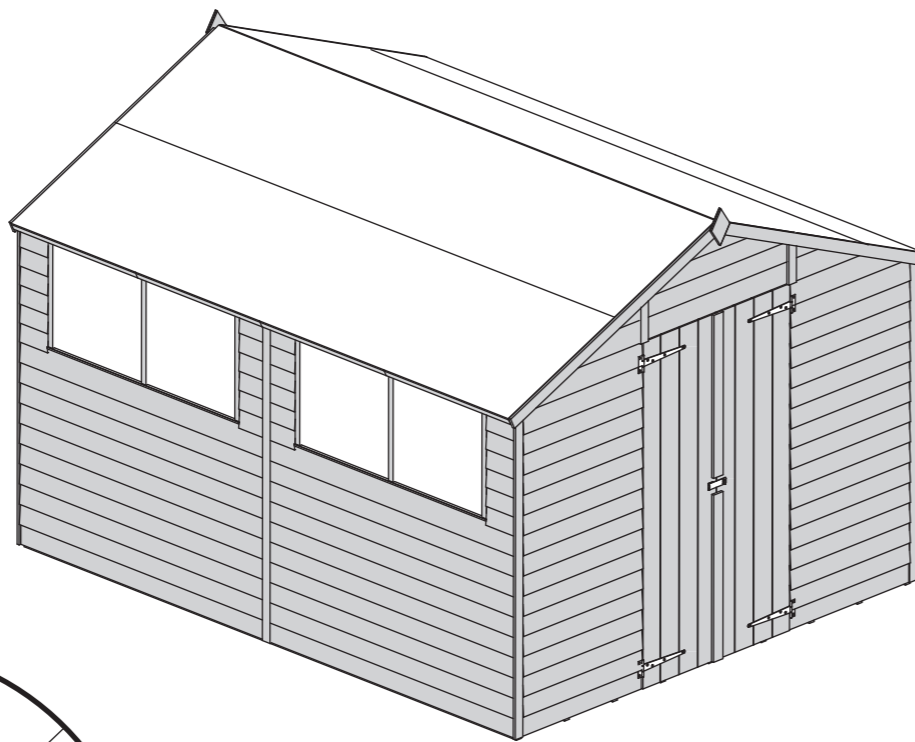

Apply treatment.



Score and peel.

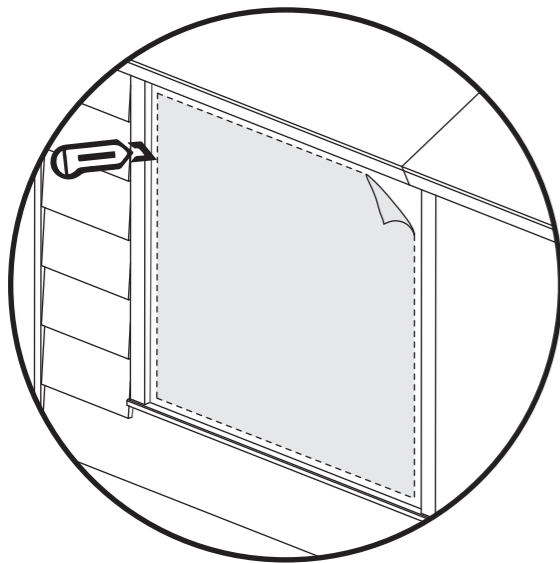

LEAVE US A REVIEW...



Want to share your experience with us?
Leave us a review on Feefo, TrustPilot or Google.

Your reviews help other people find and trust our business, as well as helping to play an important role in our growth and improvement!

TREATING YOUR GARDEN BUILDING

Preservation of wood that's outdoors is vital. A little early care will help protect your garden building, improve its appearance and ensure maximum longevity. Insects, moisture, salt, and changing weather can have dramatic effects on the stability and appearance of your garden building. Once your building is installed, you've checked it over and you're happy with it, you can take a few basic precautions to prepare it for the elements. Treating your garden building helps prevent decay and, by repelling water, discourages the growth of moulds and fungi that could jeopardise the structural integrity of the wood.

Dip Treated buildings - Require a preservative treatment to protect against rot and decay and a waterproof treatment to prevent water ingress
Pressure Treated buildings - Require a waterproof treatment to prevent water ingress
Log Cabins/Insulated Garden Rooms - Are supplied untreated and require a preservative and waterproofing treatment.



ANY QUESTIONS?
Scan the QR code to contact us via our customer portal.

To apply a preservative and water proofing treatment (pressure treated products do not require a preserver), follow the manufacturer's instructions but in principle, stick to the following steps:

- ✓ Weather permitting, ensure to treat your garden building within 14 days of installation.
- ✓ Wear latex or rubber gloves, eye protection and (if spraying) a mask.
- ✓ Prepare the wood, by sanding down any ridges or inconsistencies in the wood, smoothing out knots and end-cuts.
- ✓ Choose a dry day to treat your garden building. If you're spraying rather than brushing paint on, avoid a windy day.
- ✓ Be sure you can safely reach all the sections you need to paint - and if you need a ladder, make sure it's safely positioned before climbing. Lay dust sheets around to avoid paint splatters on your base or surrounding plants.
- ✓ Tape around windowpanes to avoid smears when you're painting the frames.
- ✓ Keep pets and small children out of the way. The last thing you want is to have fur on your garden building paint, or little painted footprints all over your garden and home.
- ✓ Fill any gaps in the building's body with caulk or wood filler to prevent water and draughts getting in. Silicone based caulk is flexible and will move with the timber when temperature and humidity change. Allow to dry completely before treating. A handy tip for finding gaps is to go into your garden building and look for light leaking through joins and frames. If light gets in, then so will water.
- ✓ Liberally apply at least two coats of the treatment products with a brush or spray, taking care to allow the first coat to completely dry before applying the second.
- ✓ Make sure the solution permeates the whole of the surface area, especially around natural cracks, end cuts and nail/screw holes.



APPLY WOOD TREATMENT
IMMEDIATELY
AFTER ASSEMBLY



1 Perimeter

Check around the perimeter of your product to ensure there are not trees or plants that are in contact with or overhanging the building. This can affect airflow and overhanging trees, or branches can damage the roof, it is advised to keep plants at a distance.

2 Repair

Inspect the interior and exterior of the product to look for splits, cracks, and holes. Although this is a natural occurrence it can be prevented. A wood filler can be used to close the splits, cracks, and holes.

3 Roof

Check your roof regularly for tears, splits, damaged wood and fallen debris. If you notice any of this immediate repair is critical.

4 Doors & Windows

Expansion and contraction can cause doors and windows to stick or become difficult to open. Small adjustments to the hinge position can be made to the doors and windows to allow free movement.

5 Oil

Hinges can seize up over time, apply lubricant to the hinges and locks annually.

6 Screws & Bolts

It is advised to check all screws and bolts and tighten any loose you might find. For log cabins specifically the storm braces will require loosening. During humidity and temperature changes (seasons) to allow expansion and contraction to prevent gaping, twisting, popping, and warping.

7 Wash

At least once a year, give the outside of you building a good wash, to remove cobwebs, leaves, or any other dirt that may accumulate on the exterior.

8 Airing

Airing your product regularly prevents the build up of condensation which can cause the timber to warp, bow, boards to pop, distortion, rot and mould. Condensation can build up over time or daily, it is caused by a rise and fall in temperature.

Excessive moisture levels within your building can cause water to collect on the roofs, walls and floors internally. Leaving doors and windows open regularly can help combat the natural moisture build up.

9 Clean & Tidy

It is good practice to clean the inside and outside of your product regularly. Clear out the contents, sweep the floor, remove dirt and cobwebs. Check for areas of damp and investigate the cause to remove and prevent future occurrences. Check the ground around your product for build up of debris such as leaves, remove and ensure there is clear ventilation underneath the floor.

Additional Playhouse Maintenance:

It is recommended that the following checks and maintenance are carried out at the beginning of each season as well as at regular intervals during the usage season.

- Check all nuts /bolts/ screws for tightness and tighten when required.
- Check for movement / opening of wood giving rise to protrusion of nail heads and tips.
- Check hinges.
- Replace defective parts in accordance with the manufacturers instructions.
- Check any crossbeams, suspensions and anchors.
- If a swing is included; check the swing seat, chains and ropes.

IF THESE CHECKS ARE NOT CARRIED OUT THE ACTIVITY TOY COULD BECOME A HAZARD

All our garden buildings have been designed and manufactured with care and attention to be the perfect addition to your outdoor space. To ensure you do get the best out of your new garden building and to increase the longevity we advise that you follow the product instructions and our manufacturer's recommendations as detailed below. Thank you for choosing a Mercia Garden product!

1 Choosing the most suitable location for your garden building...

A minimum of 60cm should be left around the perimeter of your garden building to allow access for maintenance, annual treatment and to allow air flow around the building.

Where possible you should avoid placing your garden building underneath large trees to prevent the tree causing damage to the building.

2 Preparing the base for your garden building...

All our buildings must be built on a firm, level base to ensure the longevity of the building and prevent the wood from distorting. We recommend either concrete, concrete slabs or a wooden base, such as our 'Portabase'.

The base should be slightly smaller than the external measurement of the building, i.e. the cladding should overlap the base, creating a run off for water and preventing water from pooling underneath the building.

We also recommend that the floor of the garden building is a minimum of 25mm above the surrounding ground level to avoid flooding.

3 After installation...

Once your garden building has been installed, it will need to be treated within 14 days (weather permitting) and annually to prevent the timber from deteriorating and to waterproof it. This is required to maintain the anti-rot guarantee.

Dip Treated buildings - Require a preservative treatment to protect against rot and decay and a waterproof treatment to prevent water ingress.

Pressure Treated buildings - Require a waterproof treatment to prevent water ingress.

Log Cabins/Insulated Garden Rooms - Are supplied untreated and require a preservative and waterproofing treatment.

We also recommend using a silicon sealant on the inside and outside of the windows as soon as possible after assembly and treatment to fully seal the windows.

Roofing felt/covering should be checked annually and replaced or fixed accordingly.

4 General maintenance and wood characteristics

As wood is a natural material it may be affected by the following:

Shrinkage and warping - The timber used in the construction of your garden building will have retained some of its natural moisture content. The moisture content of the timber will vary, depending upon prevailing environmental conditions, which will result in the components either naturally expanding or contracting. As the components dry out, shrinkage may occur. A good waterproofing treatment from the start is the best protection to minimise the effect of moisture loss/intake.

In extended periods of very warm weather getting some moisture to the building will help the overall balance. You can do this by spraying it down lightly with a garden hose. In contrast, after snow fall try to remove the snow as best as possible from the roof to prevent moisture intake and to remove the extra weight.

Top tip - using a garden brush will help you to reach the highest part of the building to remove snow and any debris left from bad weather.

Damp and mould - During the winter months, cold and damp conditions can result in an increased amount of moisture within your garden building, especially when used infrequently. Condensation can form on the timber and other items stored within your garden building. If left this moisture is likely to cause mould and mildew.

To prevent the build-up of moisture, we recommend leaving the door or windows of your building open from time to time, to allow the fresh air to circulate. We also advise against storing wet or damp items in your garden building as this will also increase the level of moisture in the building. If mould or mildew does start to form within your building we recommend using an anti-mould cleaner to remove it and to prevent it spreading, which if left untreated could permanently damage your garden building.

Splits, cracks and knots - You may notice small splits and cracks in some components or holes may appear where knots shrink and fall out. This will not affect the structure of your Garden building however, if you wish to fill them this can be easily done using any good quality wood filler.

Sap - is naturally occurring in wood and may appear in some boards of your garden building. If you wish to remove the sap, we advise waiting until it is dry and then using a sharp knife to carefully remove it. If the removal of the sap causes a hole in the timber, we recommend using a good quality wood filler to fill it.

For more handy hints and tips on how to care and maintain your garden building please refer to the MGP Customer Portal at www.mgplogistics.co.uk

Any further questions?



Contact our Customer Service Team via the MGP Customer Portal at: www.mgplogistics.co.uk

1

Manufacturer's Warranty

All Mercia Garden Products are supplied with a 1 year warranty on all parts against manufacturing defects.

This warranty does not cover movement, warping or splitting of timber products over time.

This warranty will be voided if any of the following occur:

1. The building has been customised or modified/adapted in any way.
2. The person claiming is not the original purchaser of the building.
3. Any damage has been caused by or as a result of misuse.
4. The building has not been maintained and cared for in accordance to our advisories and manufacturer's recommendations.
5. The building has not been treated annually or as per the manufacturer's recommendations, please ensure receipts are kept to validate this claim.
6. The building has not been erected, fitted or installed as per the supplier instructions.
7. The building has not been erected on a suitable sized firm flat, solid level concrete/slab base or placed on pressure treated bearers.
8. The building is or has been placed with 2 feet (600mm) of any obstructions (walls, trees, plants, fences etc.) which can allow moisture to penetrate the timber.
9. The roofing felt has been incorrectly fitted or damaged, allowing water ingress, or has not been properly maintained.
10. Any windows and joints have not been sealed, inside and out, with silicone or other watertight sealant.
11. Any timber has been cut, pierced or drilled without subsequent application of approved cut-end treatment.

REGISTER FOR YOUR
10 YEAR
ANTI-ROT
GUARANTEE TODAY



www.mgplogistics.co.uk

2

Anti-rot Guarantee

Mercia Garden Products offer a 10 year anti-rot guarantee on all dip treated (a preparatory treatment) and 15 years on all pressure treated products. This guarantee covers solid timber against rot, decay, blue stain and insect attacks.

To validate the guarantee, the building must be treated (as detailed within manufacturer's recommendations) within 14 days (weather permitting) of assembly and annually thereafter.

This guarantee does not cover movement, warping or splitting of timber products over time.

This guarantee will be voided if any of the following occur:

1. The building has been customised or modified/adapted in any way.
2. The person claiming is not the original purchaser of the building.
3. Any damage is caused by or as a result of misuse.
4. The building has not been maintained and cared for in accordance to our advisories and manufacturer's recommendations.
5. The building has not been treated annually or as per the manufacturer's recommendations, please ensure receipts are kept to validate this claim.
6. The building has not been erected, fitted or installed as per the supplier instructions.
7. The building has not been erected on a suitable sized firm flat, solid level concrete/slab base or placed on pressure treated bearers.
8. The building is or has been placed with 600mm of any obstructions (walls, trees, plants, fences etc.) which can allow moisture to penetrate the timber.
9. The roofing felt has been incorrectly fitted or damaged allowing water ingress, or has not been properly maintained.
10. Any windows and joints have not been sealed, inside and out, with silicone or other watertight sealant.
11. Any timber has been cut, pierced or drilled without subsequent application of approved cut-end treatment.