

8FT LEAN-TO COMBI SHED AND GREENHOUSE

Please retain product label and instructions for future reference

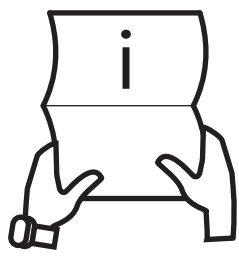

BEFORE YOU START PLEASE READ THE INSTRUCTIONS CAREFULLY

- Check the pack and make sure you have all the items listed in the parts list provided.
- When you are ready to start, make sure you have the right tools at hand (not supplied - see the equipment list on next page).
- Ensure there is plenty of space and a clean dry area for assembly.
- Ensure you have enough time to fully assemble the main structure of your Garden building.

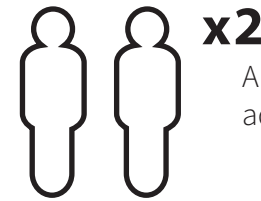

x2

All buildings should be erected by two adults.

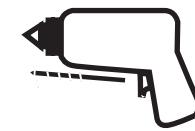

2mm Drill bit

For ease of assembly, you **MUST** pilot drill all screw holes and ensure all screw heads are countersunk.



For ease of assembly, you will need a tape measure to check dimensions of components and fixings.



Winter = High Moisture = Expansion
Summer = Low Moisture = Contraction



CAUTION

Every effort has been made during the manufacturing process to eliminate the prospect of splinters on rough surfaces of the timber. You are strongly advised to wear gloves when working with or handling rough sawn timber.

Protim Aquatan T5 (621)

Your building has been dip treated with Aquatan.

Aquatan is a water-based concentrate which is diluted with water, the building has been treated by the correct application of Aquatan solution and then allowed to dry.

Aquatan is a decorative finish to colour the wood, which is applied industrially to timber fence panels and garden buildings.

Aquatan undiluted contains: boric acid, sodium hydroxide 32% solution, aqueous mixture of sodium dioctyl sulphosuccinat and alcohols: 2, 4, 6-trichlorophenol.

REGISTER FOR YOUR
15 YEAR
ANTI-ROT
GUARANTEE TODAY

In all instances for assistance with your product or to register your anti rot guarantee, please contact us via our customer portal



www.mgplogistics.co.uk

Mercia Garden Products Limited, Sutton On Trent, Newark, Nottinghamshire, NG23 6QN

Screws & Nails

Measure overall length

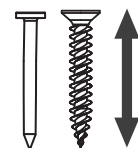

Bolts

Measure under the head

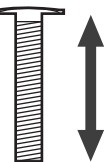

LOCATION FOR YOUR GREENHOUSE

Ensure you have a suitable space available and cleared before beginning assembly:

- A minimum of 600mm should be left around the perimeter of your garden building to allow access for maintenance, annual treatment and to allow air flow around the building.
- To fit your glazing, you require a minimum of 1500mm clearance on one side of your Garden Building. This must be the side where the lowest end of the sloping Greenhouse roof will be positioned.
- Where possible, avoid placing your garden building underneath large trees to prevent the tree causing damage to the building.

BUILDING A BASE

When thinking about where the garden building and where the base is going to be constructed:

Ensure that there will be access to all sides for maintenance work and annual treatment.

Ensure the base is level and is built on firm ground, to prevent movement. Refer to Page 5 for the base dimensions. The base should be slightly smaller than the external measurement of the garden building, i.e. The cladding should overlap the base, creating a run off for water. It is also recommended that the floor be at least 25mm above the surrounding ground level to avoid flooding.

TYPES OF BASE

- Concrete 75mm laid on top of 75mm hard-core.
- Slabs laid on 50mm of sharp sand.
- Wooden base - Levelled / on posts / ground screws.

TREATMENT

Once your garden building has been installed it will need to be treated within 14 days (weather permitting) and annually to prevent the timber from deteriorating and to waterproof it. This is required to maintain the anti-rot guarantee.

Dip Treated buildings - Require a preservative treatment to protect against rot and decay and a waterproof treatment to prevent water ingress.

TIMBER

As with all natural materials, timber can be affected during various weather conditions. For the duration of heavy or extended periods of rain, swelling of the wood panels may occur. Warping of the wood may also occur during excessive dry spells due to an interior moisture loss. Unfortunately, these processes cannot be avoided but can be helped. It is suggested that the outdoor building is sprayed with water during extended periods of warm sunshine and sheltered as much as possible during rain or snow.

Whilst all products manufactured are made to the highest standards of safety and in the case of children's products independently tested to EN71 level, we cannot accept responsibility for your safety whilst erecting or using this product.



TO DO LIST

- Find a suitable location to build (*see front cover for further information*).
- Build a base (*see front cover for further information*).
- Check the base is flat, level, clear of debris and has the required clearance on all sides (see page 1).
- Check you have the required equipment / tools.
- Check you have all the product items listed (*if you have missing or damaged parts please scan the QR code below to visit our online customer portal*).
- Install the product as per the step by step instructions within this pack.
- Prepare the product ready for treatment (this may include sanding).
- Apply a preserving and a waterproofing treatment within 14 days (*weather permitting*) of installation (*pressure treated products do not require a preserver*).
- Register for your anti rot guarantee (*scan the QR below*).
- Tidy the build area and dispose of any remaining parts responsibly.
- Maintain your building (*see the manufacturers recommendations at the back of this pack*).

EQUIPMENT LIST

- Hammer
- Flat Head Screwdriver
- Drill
- Drill Bit Set
- Phillips and Slotted Bit Sets
- Tape Measure
- Hand Saw
- Spirit Level
- Ladders/Steps
- Stanley Knife/Cutting Tool
- Sand Paper
- Gloves
- Silicone (For Windows Only)
- Sealant Application Gun
- Wood Filler (Optional)
- Timber Preservative Treatment (*not pressure treated products*)
- Timber Water Proofing Treatment
- Treatment Mixing Stick
- Paint Brush/Sprayer/Roller

NEED EXTRA SUPPORT

If you are unsure that your base preparation will be suitable, please contact us via our customer portal to discuss this further.

Alternatively, you can visit our website or MGP Logistics Online Portal for some further shededucation.

Website:

<https://www.merciagardenproducts.co.uk/sheducation>

MGP Logistics Online Portal:

<https://www.mgplogistics.co.uk/>

Here you will find plenty of useful information that'll help with most pre-installation and maintenance queries.



ANY QUESTIONS?

Scan the QR code to contact us via our customer portal.

NOTES

ACCESSING VIDEO GUIDES...

Some steps within this set of instructions come with an added video guide for your convenience. These can be accessed via the QR code and used to aid you in constructing that step. See below for how to use.

You can also find all the videos on our youtube channel:
<https://www.youtube.com/@merciagardenproducts8716/videos>

1. Find the QR code within the instruction step...

Step.....

Parts Needed- No. QTY 1
No. QTY 1
No. QTY 1

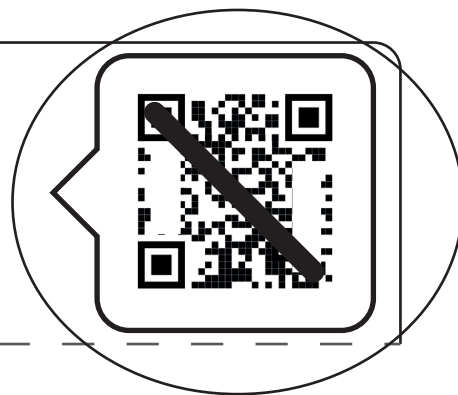

Within the instruction step, there will be an icon in the top right that has a QR code in. This is where the video can be accessed from.

Please note: not every step has a video guide.

2. Open camera app...

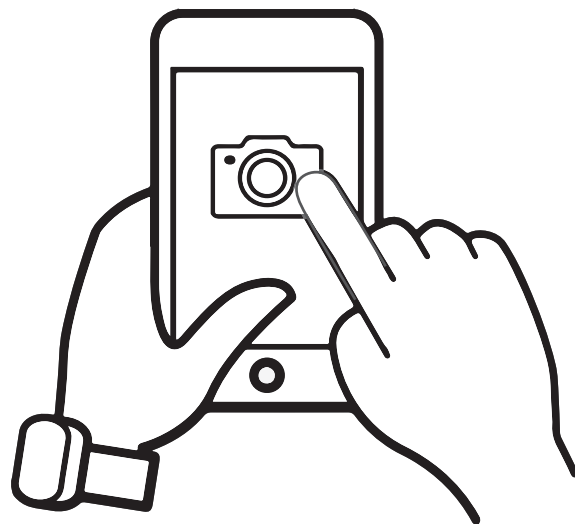

On your personal smart device (phone, tablet etc), open your camera app or QR code scanner app.

ACCESSING VIDEO GUIDES...

3. Scan QR code...



To scan the QR code, hold the camera over the QR code so that it can be seen on the screen. Once the QR code has been registered, follow the prompts on your device to open the video. (This will vary depending on your device.)

Please note: Ensure to use the back camera of your smart device as this will scan the QR code more accurately.

4. Watch the video...

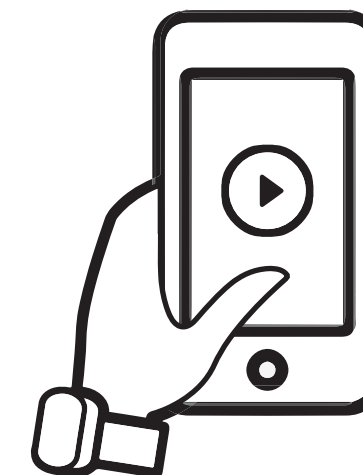

The video guide will now be displayed on your smart device.

Disclaimer: The garden building constructed in the video guides may be constructed differently to your building. Please ensure to read your instructions carefully to avoid error.

What is a Modular Garden Building?

A Modular Product allows you to choose the layout of your Garden Building, yourself.

In your Modular Combi Shed and Greenhouse this means that some panels are interchangeable with each other, such as:

The 4ft Shed Door, Shed Window and Shed Plain Panels (No. 4a, 4b & 4c) are interchangeable with each other, and can be swapped and positioned however you choose.

The 2ft Door and Glazed Panels (No. 8a & 8b) are interchangeable with each other, and can be swapped and positioned however you choose.

Please note: The buildings shown may differ in size from your chosen building however the process of interchanging the Panels is the same.

How should I position my panels?

This instruction manual contains steps to construct one building;

- 8x8 Lean-To Combi - 8x4 Pent Shiplap shed + 8x4 Lean-To Greenhouse.

This building can be constructed with the panels in different configurations, as explained above.

Please see the following pages for some inspiration of different ways you can position your panels for your chosen building size and type. Ensure you have decided how you would like your building to look before beginning construction.

We recommend positioning your Greenhouse Door on one end, as this allows for the most usable space inside your Greenhouse. However, the Greenhouse Door can be placed in any position.

What building do I have?

All of our modular garden buildings have different names and different components, so it's important to understand what building you have and what comes with it before beginning assembly. Please refer to the information below to check what type of building you have before beginning construction.

8ft Lean-to Combi Greenhouse.

The building you have purchased is referred to generically as a '8ft Lean-To Combi' and this instruction manual contains steps to construct;

- 8x8 Lean-To Combi - 8x4 Pent Shiplap shed + 8x4 Lean-To Greenhouse.

For your exact building reference codes and a full building breakdown, please see the pages to follow that contain your chosen building size. For base options, please see the 4ft Base assembly instructions guide.

What does the building name mean?

The building you have purchased will be named as shown above, for example: **8x8 Lean-To Combi**.

8x8 Pent Lean-To Combi:

8 - the depth of the building. This building is 8ft deep.

8 - the width of the building. This building is 8ft wide.

Pent Lean-to - the roof type. This building is a Pent Lean-To, which means the roof consists of a single sloped surface.

Combi - the building structure. This building consists of a 8x4 Pent shiplap shed and a 8x4 Lean-To Greenhouse. Together, these make up the 8ft width and both have an 8ft depth.

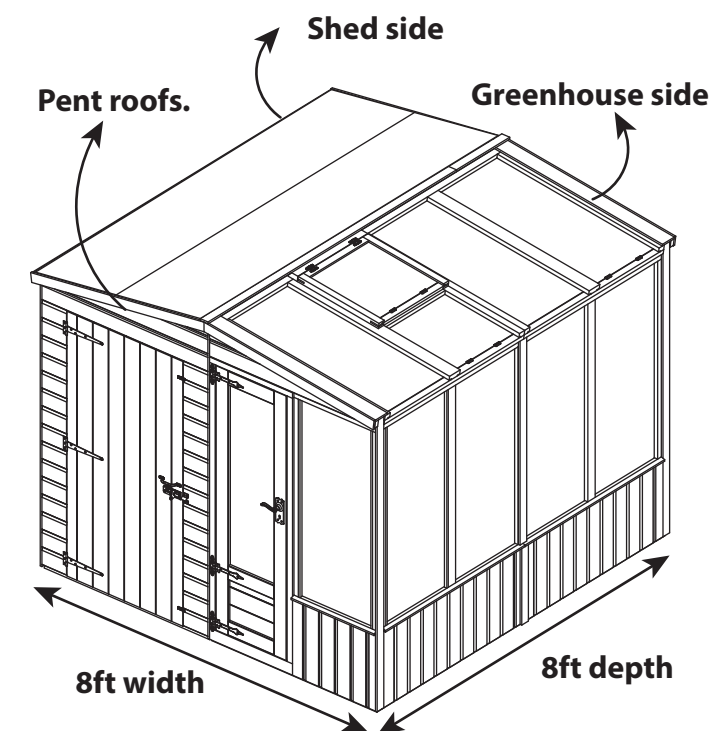

All of the buildings in this manual are 8ft wide, with differing depths. Throughout the instructions, ensure to check that you are referring to the correct building where necessary.



ANY QUESTIONS?

Scan the QR code to contact us via our customer portal.

8x8 8x4 Pent Shiplap Shed + 8x4 Lean-To Greenhouse

Standard Base

Overall Dimensions:
 Width = 2443mm
 Depth = 2550mm
 Height = 2061mm

Premium Base

Overall Dimensions:
 Width = 2443mm
 Depth = 2550mm
 Height = 2061mm

Building Breakdown
 ◦ SI-100-004-0032 - 8x8 Pent Lean-To Greenhouse and Shed Combi with Styrene.

Shed Door on the end, Greenhouse Door on the end.

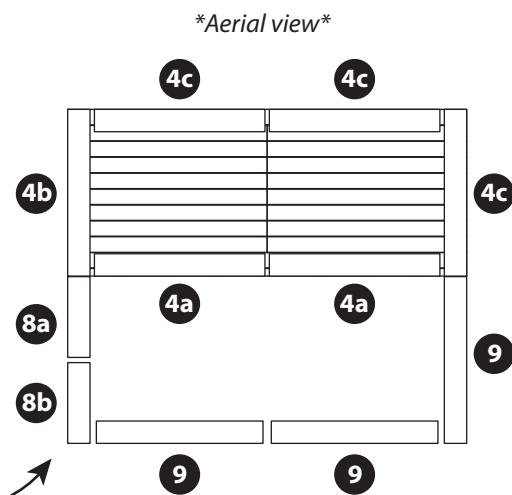
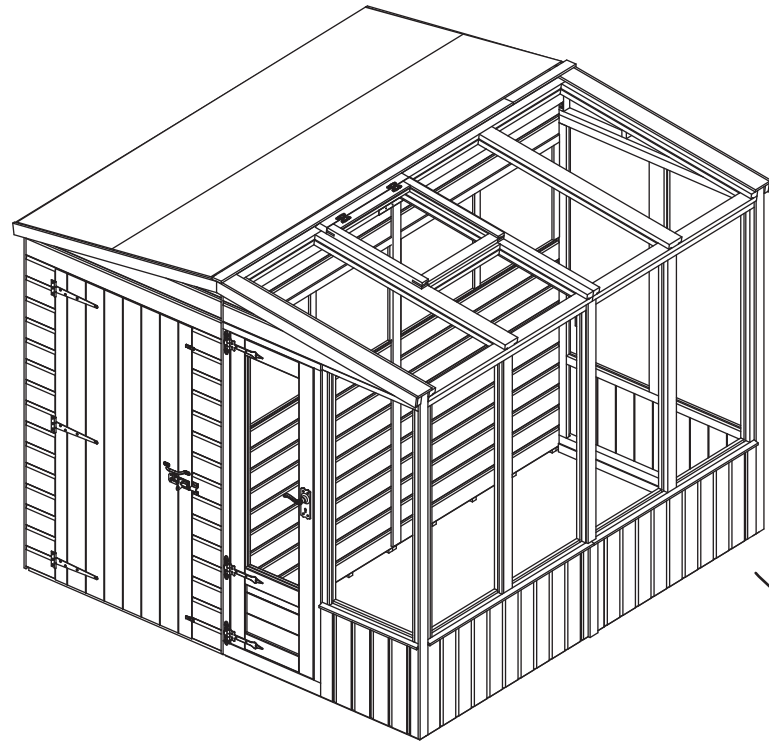

Shed Door on the end, Greenhouse Door on the opposite end.

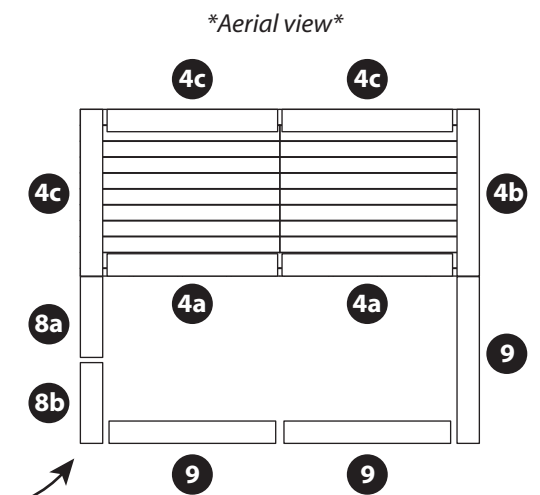
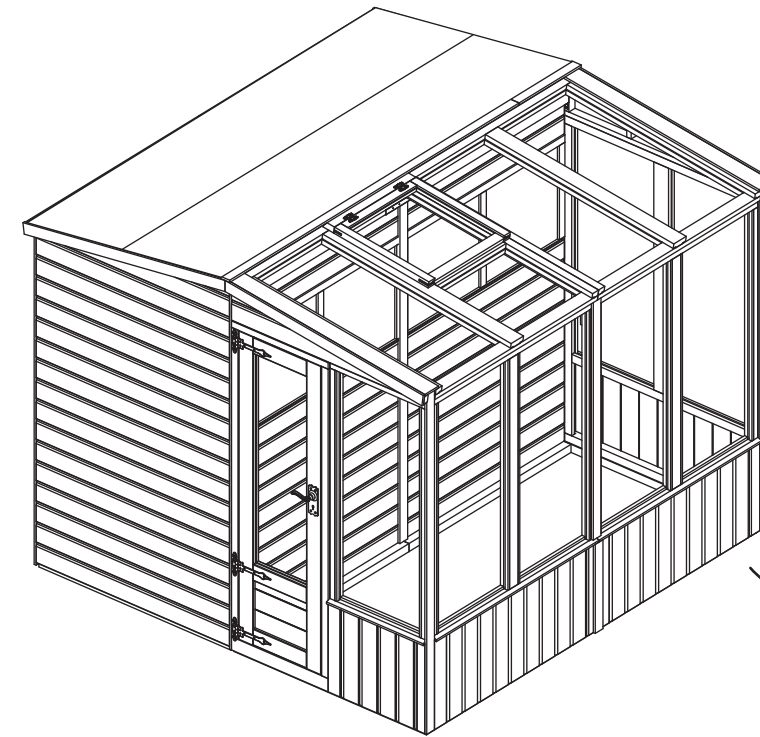

Shed Door on the inside, Greenhouse Door on the end.

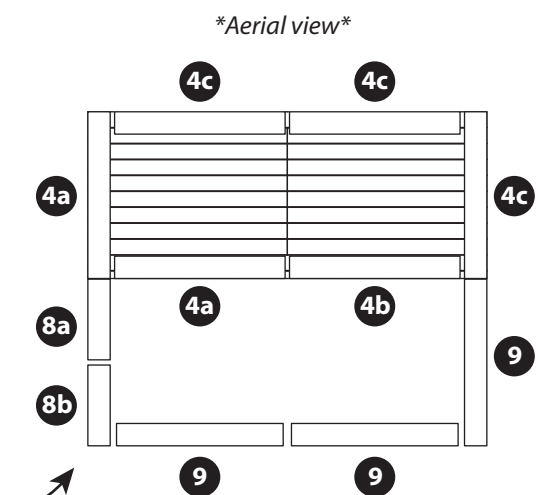
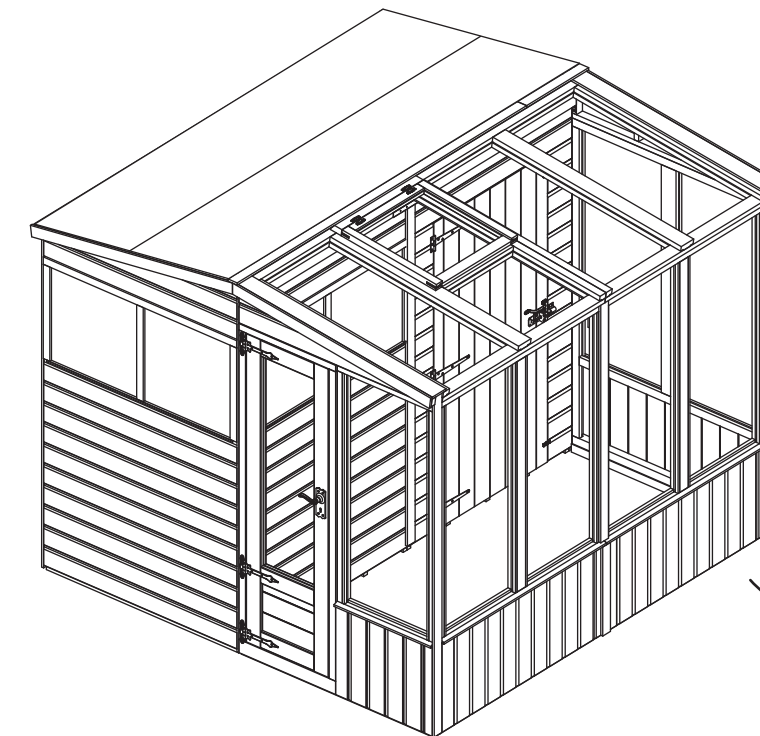
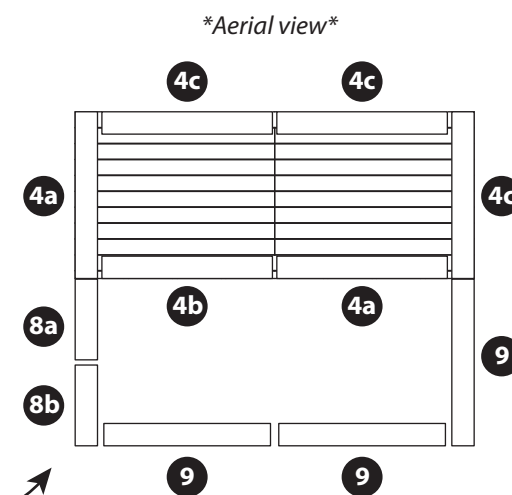
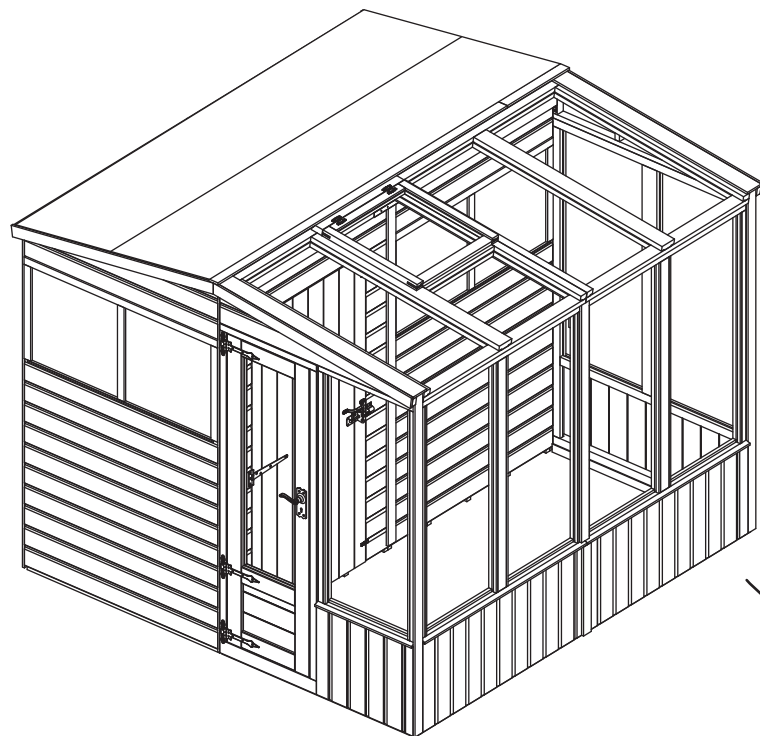

Building Contents:

In the tables to follow, please refer to the row with your chosen building size in to determine how many of each part is required.

Tip: Labelling your parts, using a pencil and masking tape, may help you to identify them easier when you need them. *NO.1 FLOOR PANEL*

We highly recommend checking you have all the required components before beginning assembly.

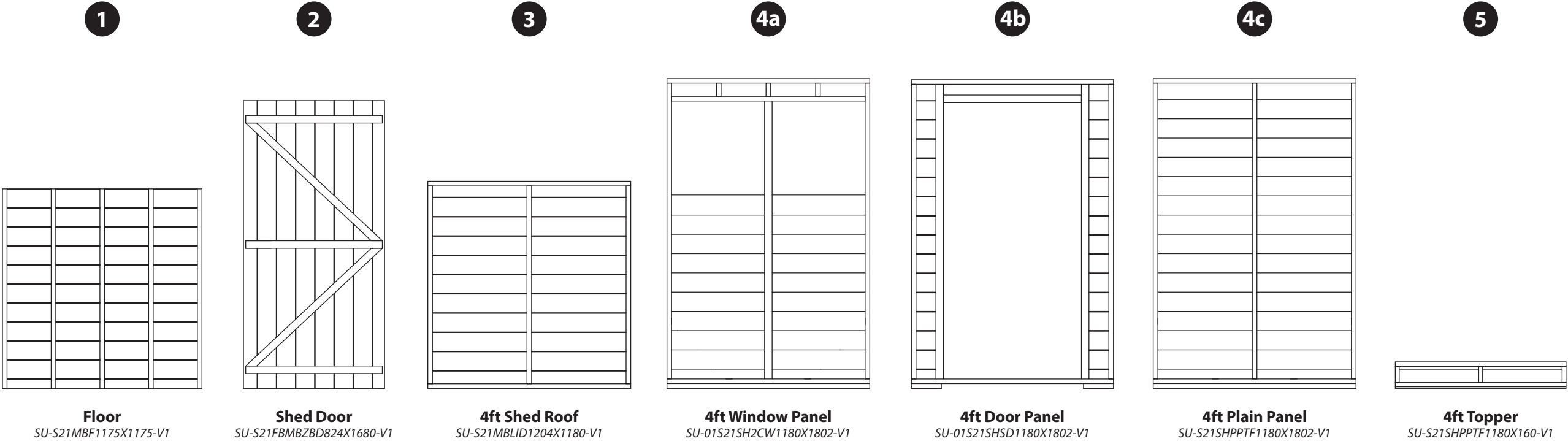

8 X 8 PENT LEAN-TO COMBI	QTY 2	QTY 1	QTY 2	QTY 2	QTY 1	QTY 3	QTY 2
---------------------------------	--------------	--------------	--------------	--------------	--------------	--------------	--------------

Building Contents:

6

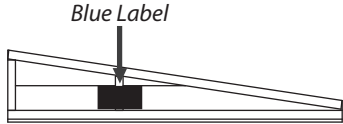

Left Gable Top
SU-S21SHPGTL1180X221-V1

7

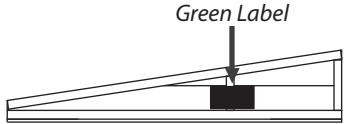

Right Gable Top
SU-S21SHPGTR1180X221-V1

8a

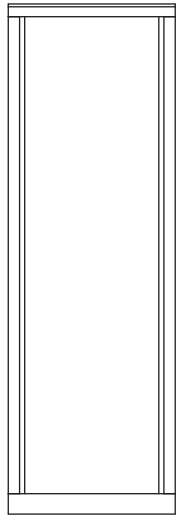

2ft Single Door Panel
SU-04S22SDP590X1802-V1

8b

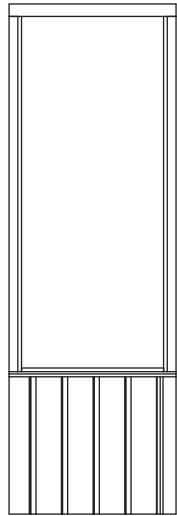

2ft Glazing Panel
SU-04S22GP1W590X1802-V1

9

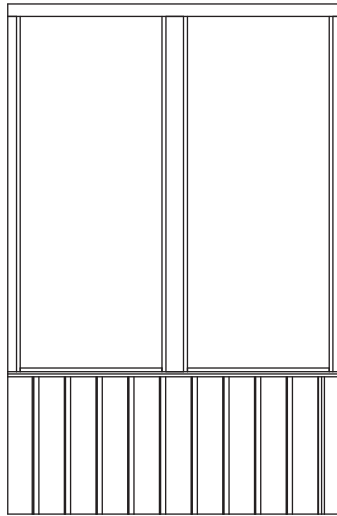

4ft Glazing Panel
SU-04S22GP2W1180X1802-V1

10

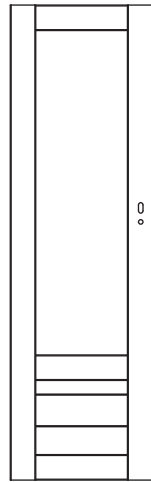

Greenhouse Door
SU-PRMHGMDSTY504X1678-V1 - STYRENE

11

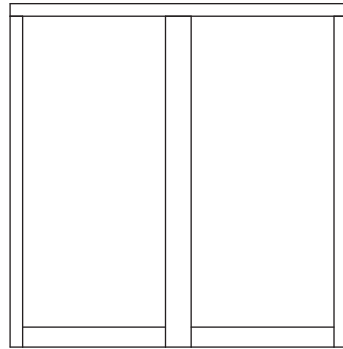

4ft Roof
SU-04S32GR2W1180X1204-V1

8 X 8 PENT LEAN-TO COMBI

QTY 2

QTY 2

QTY 1

QTY 1

QTY 3

QTY 1

QTY 1

Building Contents:

12

13

14

15

16

17

18

19

20

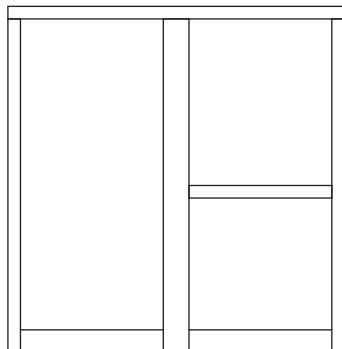

4ft Opening Window Roof
SU-04S32GROW3W1180X1204-V1

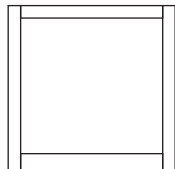

Window
SU-SW590X580-V1

End View



Floor Extension Joist
44x56x1175mm
F4456-1175mm-DT

End View



4ft Ridge Bar
27x70x1180mm
F2770-1180mm-DT

End View



Panel Brace
27x44x500mm
F2744-G-540mm

End View



Door Block
27x44x150mm
F2744-150mm

End View



Truss block
27x44x140mm
F2744-G-160mm

End View



Greenhouse Truss Frame
27x44x1122mm
F2744-G-1162mm

End View



Top Window Strip
12x40x1180mm
S1240-1180mm

8 X 8 PENT LEAN-TO COMBI

QTY 1

QTY 1

QTY 2

QTY 2

QTY 12*

QTY 2

QTY 2*

QTY 1

QTY 2







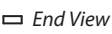

Included in add on
'Panel Brace kit'
only.

*You may have more of this part that required.

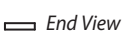
**This part will be longer than needed and requires cutting to size when used. This will be explained when required within the instruction step.

Note: one piece may be required to be cut into multiple different sizes. Do not dispose of off-cuts until the building is fully constructed as they may be needed in another step.

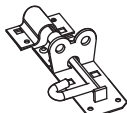
Building Contents:

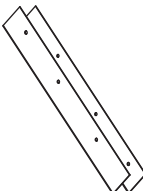
	21	22	23	24	25	26	27	28	29	30	31	32
												
	Window Strip 12x40x513mm S1240-513mm	Window Block 65x35x590mm F6535-G-590mm	Eaves Frame** 27x44x2000mm F2744-2000mm-DT	Cover Trim** 12x56x2100mm S1256-2100mm	Roof Trim** 12x100x2100mm S12100-2100mm-DT	Fascia** 12x40x2000mm S1240-2000mm	Fascia** 12x60x2000mm S1260-2000mm	T-Hinge PI-07-0021	Pad Bolt PI-07-0035	Turn Button PI-07-0034	Door Handle PI-07-0240	U-Channel PI-07-0013
8 X 8 PENT LEAN-TO COMBI	QTY 10	QTY 1	QTY 6	QTY 12*	QTY 2	QTY 2	QTY 6*	QTY 3	QTY 1	QTY 2	QTY 1	QTY 1

*You may have more of this part that required.

**This part will be longer than needed and requires cutting to size when used. This will be explained when required within the instruction step.

Note: one piece may be required to be cut into multiple different sizes. Do not dispose of off-cuts until the building is fully constructed as they may be needed in another step.

Building Contents:

33

34

35

36

37

38

39

40

41

42

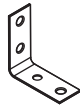

Corner Brace
PI-07-0012

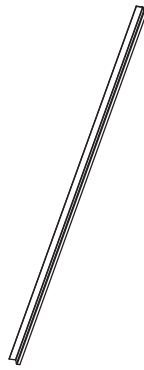

Plastic Window Cill
PI-08-0013

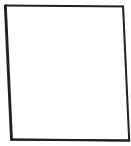

Styrene
PI-05-0114



Felt**

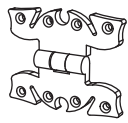

Butt-Hinge
PI-07-0004

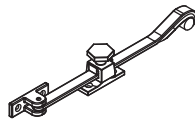

Casement Stay
PI-07-0080

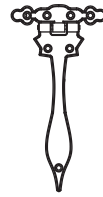

Greenhouse T-Hinge
PI-07-0002

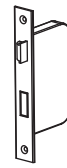

Lock
PI-07-0017



Key-Plate
PI-07-0017

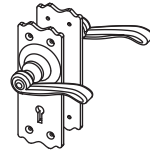

Handle Set
PI-07-0006

8 X 8 PENT LEAN-TO COMBI

QTY 4

QTY 2

QTY 4

QTY 1

QTY 2

QTY 1

QTY 3

QTY 1

QTY 1









QTY 1

****This part will be longer than needed and requires cutting to size when used. This will be explained when required within the instruction step.
Note: one piece may be required to be cut into multiple different sizes. Do not dispose of off-cuts until the building is fully constructed as they may be needed in another step.**

Screw Packs

In the table below, please refer to the row with your chosen building size and type in to determine how many of each screw is required.

There may be extra screws in the pack.

								
	70mm Screw	60mm Screw	50mm Screw	40mm Screw	30mm Screw	30mm Black Screw	16mm Black Screw	Felt Tacks
8 X 8 PENT LEAN-TO COMBI	QTY 23	QTY 36	QTY 122	QTY 38	QTY 159	QTY 51	QTY 4	QTY 100



Missing parts?

Scan the QR code to visit our customer portal where you can quickly raise any missing or damaged parts and get a replacement sent out ASAP.



Before assembly, please make sure you have a suitable base ready to install your building onto.

Pre-Assembly

Parts Needed				
Building	No. 4a	No. 4c	No. 16	40mm screw
All sizes	QTY 2	QTY 3	QTY 10	QTY 20

If you have not purchased a 'Panel Brace' add-on kit, please skip to step 1.

Please note: You have been supplied with 12 Panel Braces (No. 16) however you may only need to use 10.

Place the 4ft Window Panel (No. 4a) and 4ft Plain Panels (No. 4c) face down on a flat and level base.

At the bottom of each panel, locate the Panel Braces (No. 16) onto the internal cladding of the panels and up to the framing, ensuring the framing is flush and level, as shown.

****Tip: To identify the bottom of the panel, look for where the cladding overhangs past the framing. This is the bottom of the panel.**

The 4ft Panels (No. 4a & 4c) should have two braces per panel, as shown.

Secure the Braces (No. 16) in place by screwing through the outside of the panel framing into the brace behind using 1x40mm screw per end, as shown.



IMPORTANT: Pre-drill before fixing screws.

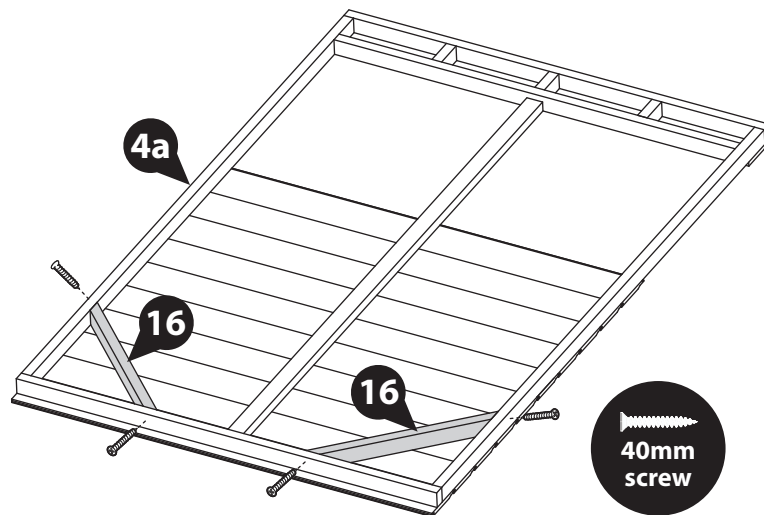
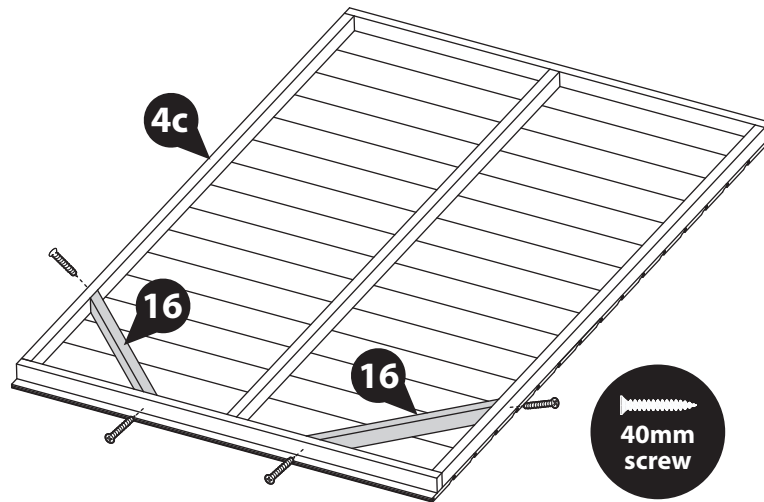

Step 1

Parts Needed				
Building	No. 2	No. 4b	No. 28	30mm screw
All sizes	QTY 1	QTY 1	QTY 3	QTY 21

Place the 4ft Door Panel (No. 4b) face up onto a flat and level base.

Place the Shed Door (No. 2) within the 4ft Door Panel (No. 4b), ensuring there is equal spacing on each side.

Locate the T-Hinges (No. 28) onto the Door and Door Panel, ensuring the hinge lines up with the framing on the inside of the Door.

Secure in place using 7x30mm screws per hinge, ensuring that the screws go through the cladding and into the framing behind.

****PLEASE NOTE**** Before fitting the hinges, ensure the Door is in the correct position depending on which side you want the Door to open. See the illustrations below which show the Door's internal framing.



IMPORTANT: Pre-drill before fixing screws.

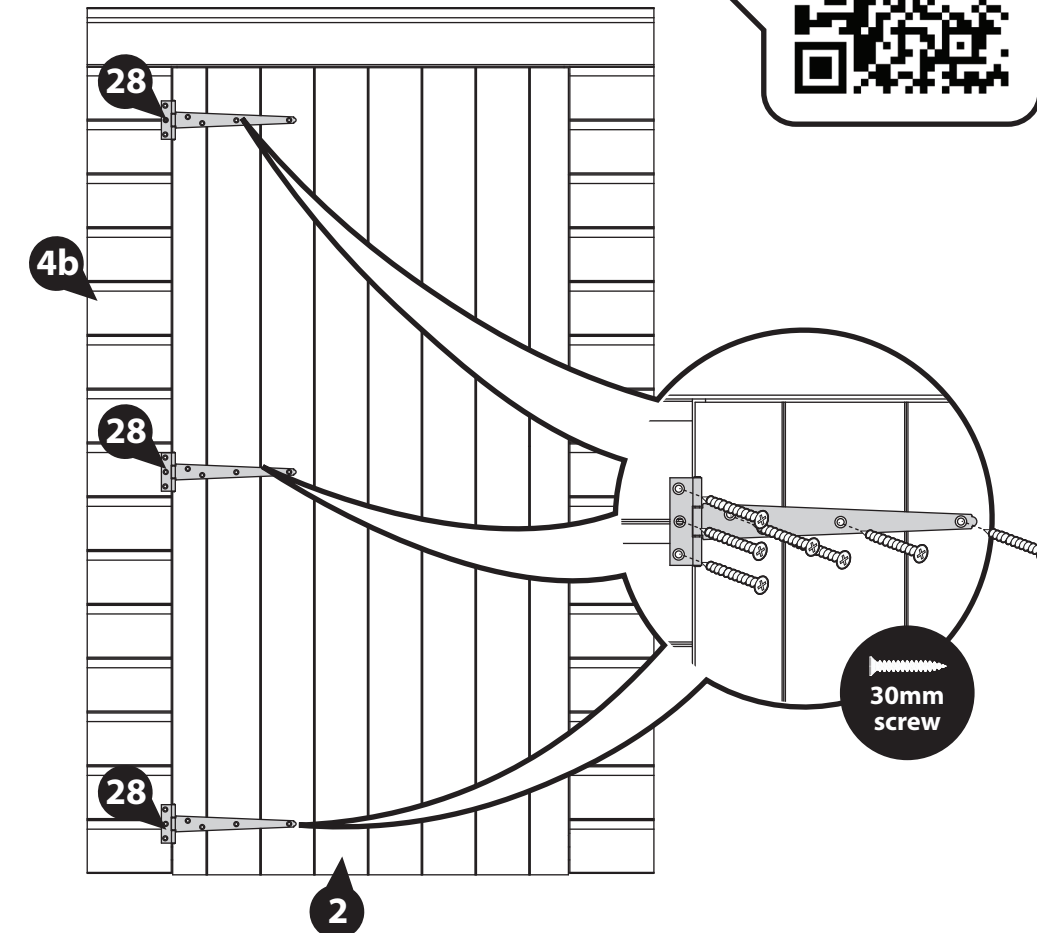

Opens from the Left

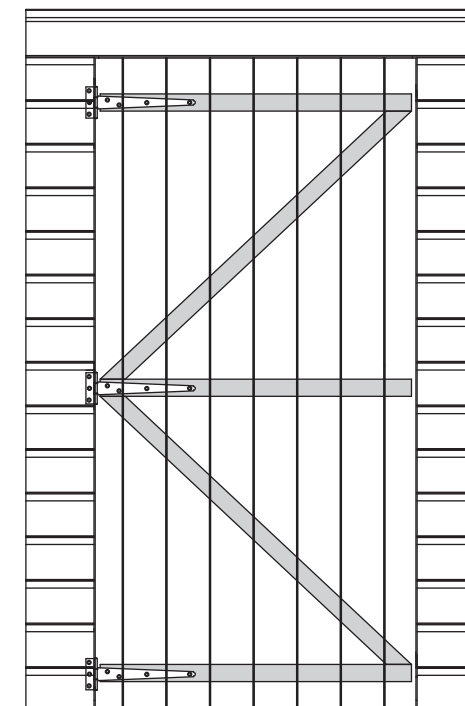

Opens from the Right

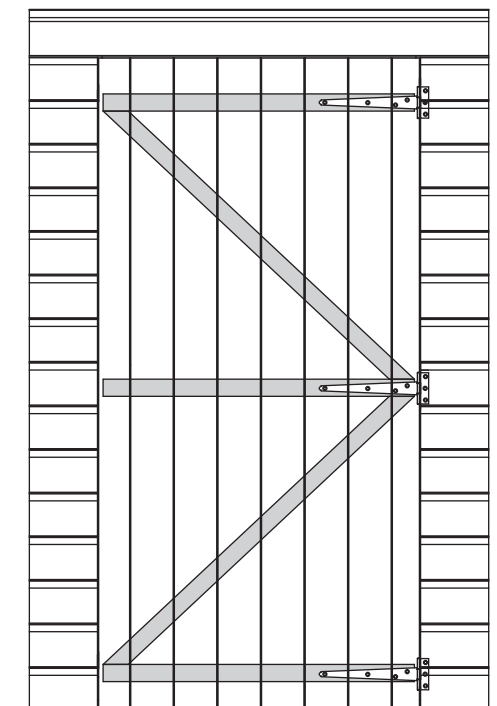

Step 2

Parts Needed

Building	No. 2	No. 17	30mm screw
All sizes	QTY 1	QTY 2	QTY 4

Please note: Your Handle can be positioned horizontally or vertically. Please decide which works best before fitting your door blocks. Follow the relevant step below depending on your choice.

Position one Door Block (**No. 17**) horizontally underneath the central piece of framing on the Door (**No. 2**), ensuring the ends and sides are flush.

Ensuring to support the Block, secure in place using 2x30mm screws, screwing through the outside of the Door cladding into the block behind.

Horizontal handle:

Locate the second Door Block (**No. 17**) on the top of the central piece of framing, on the opposite side to the already fitted block. Ensuring the ends and sides are flush, secure in place using 2x30mm screws, screwing through the outside of the Door cladding into the block behind.

Vertical handle:

Locate the second Door Block (**No. 17**) vertically on the top of the central piece of framing, on the opposite side to the already fitted block. Ensuring the ends and sides are flush, secure in place using 2x30mm screws, screwing through the outside of the Door cladding into the block behind.

IMPORTANT: Pre-drill before fixing screws.

Horizontal Handle:

Opens from the Left

Opens from the Right

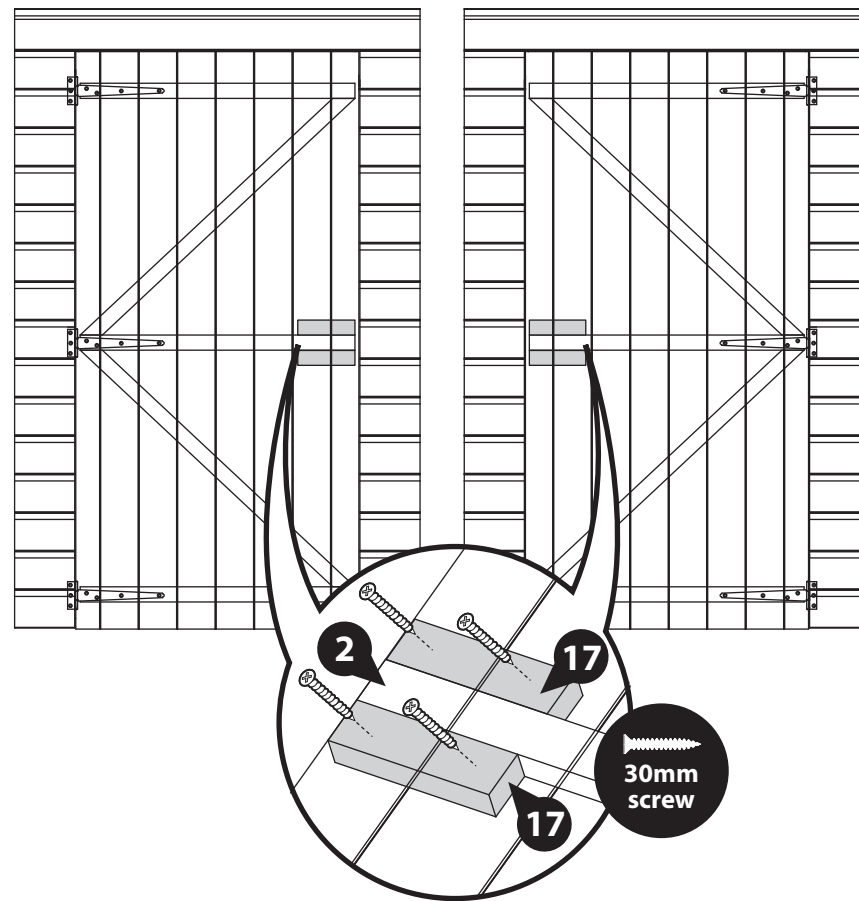

Vertical Handle:

Opens from the Left

Opens from the Right

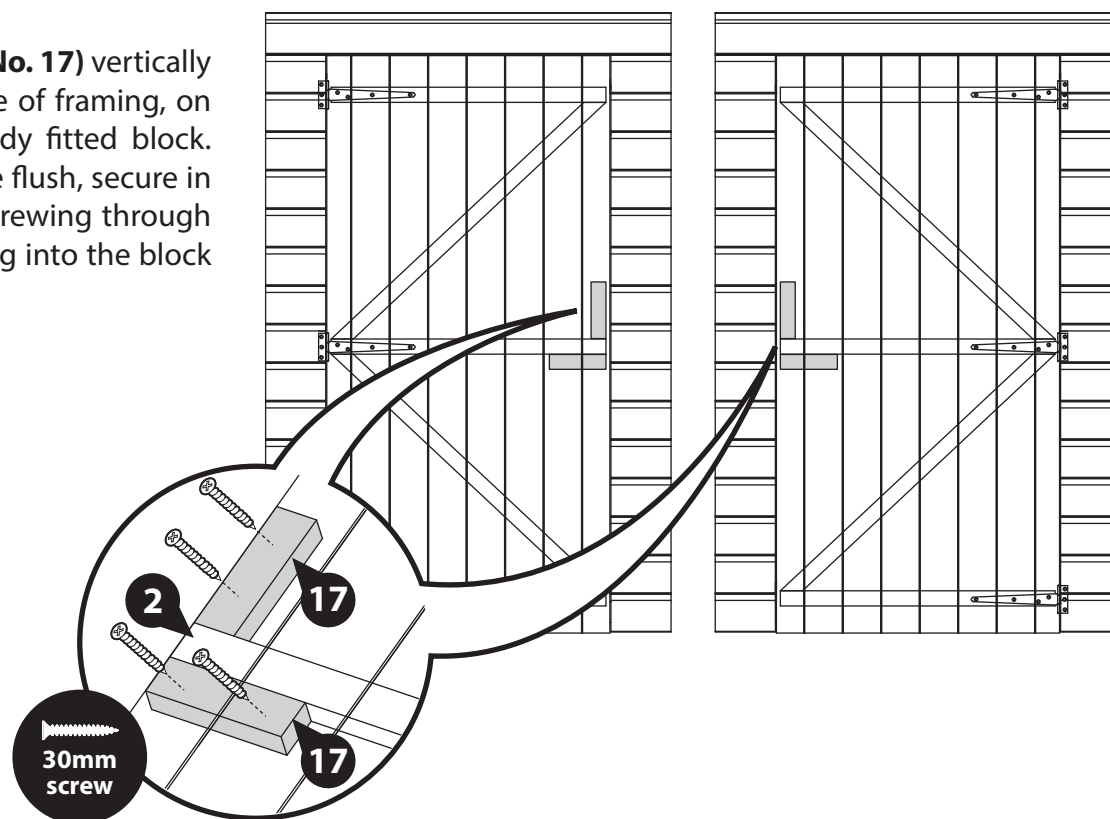

Step 3

Parts Needed

Building	No. 29	30mm screw
All sizes	QTY 1	QTY 10

Locate the Pad Bolt (**No. 29**) onto the Door (**No. 2**) ensuring to line it up with the bottom internal door block, and the retainer to the 4ft Door Panel (**No. 4b**).

Fix in place using 10x30mm screws. Ensure to screw through the cladding into the framing block behind.

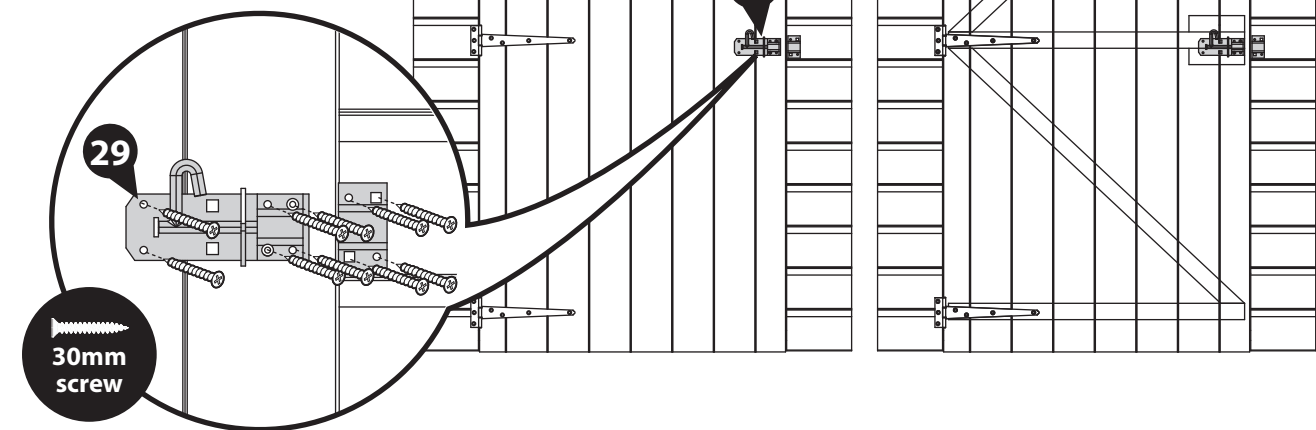

Step 4

Parts Needed

Building	No. 30	30mm screw
All sizes	QTY 2	QTY 2

Position a Turn Button (**No. 30**) to the top and bottom of the 4ft Door Panel (**No. 4b**) and fix in place using 1x30mm screw per turn button.

Ensure the Turn Buttons rotate to sit across the Door and the Door Panel, as these will help to hold the Door shut.

These Turn Buttons help to keep your Doors straight during high and low levels of moisture content in the air.

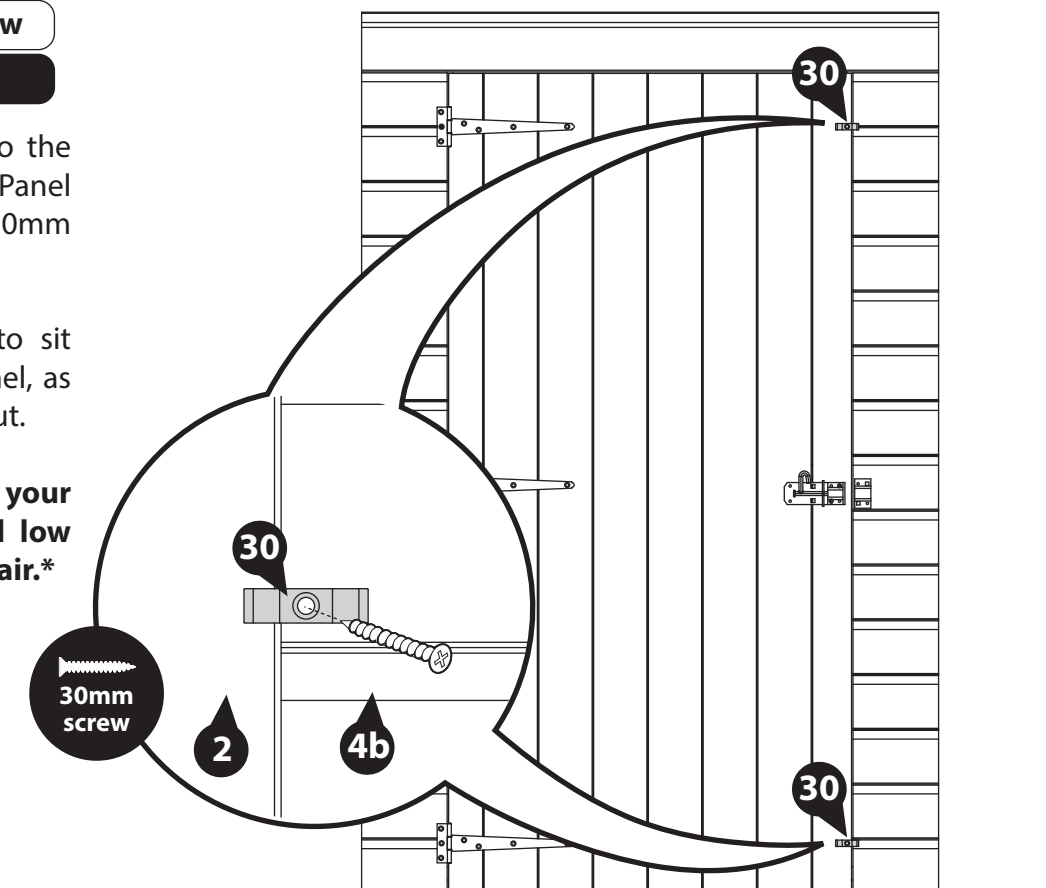

Step 5

Parts Needed

Building	No. 31	30mm screw
All sizes	QTY 1	QTY 4

Please note: Your Handle (No. 31) can be positioned horizontally or vertically. Please decide which works best before fitting.

Locate the Handle (No. 31) onto the Door (No. 2) so it sits just above the previously fitted Pad Bolt, ensuring to line it up with the internal door blocks.

Secure in place using 4x30mm screws. Ensure to screw through the handle and cladding into the framing block behind.

Horizontal Handle:

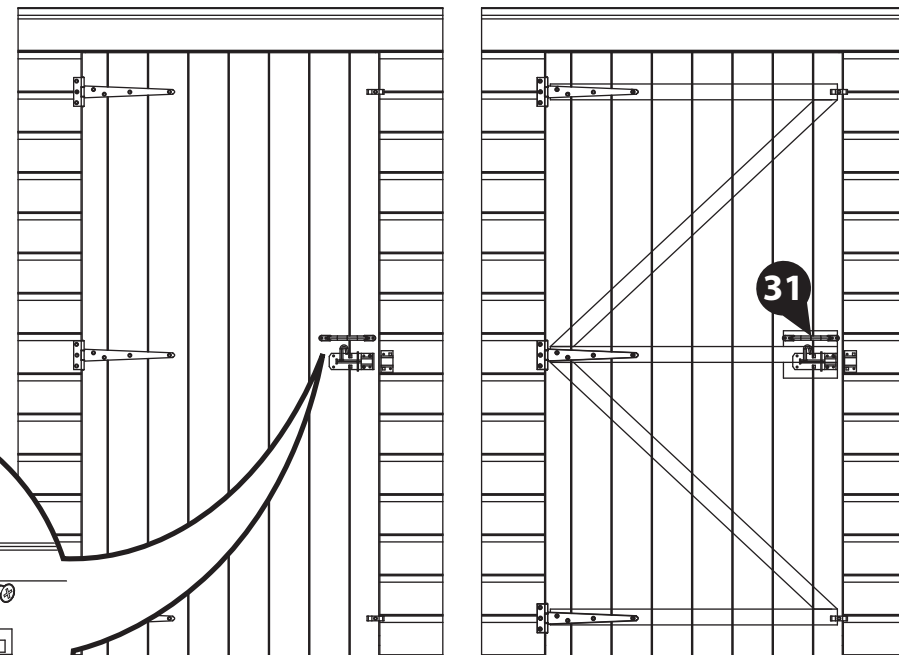

Vertical Handle:

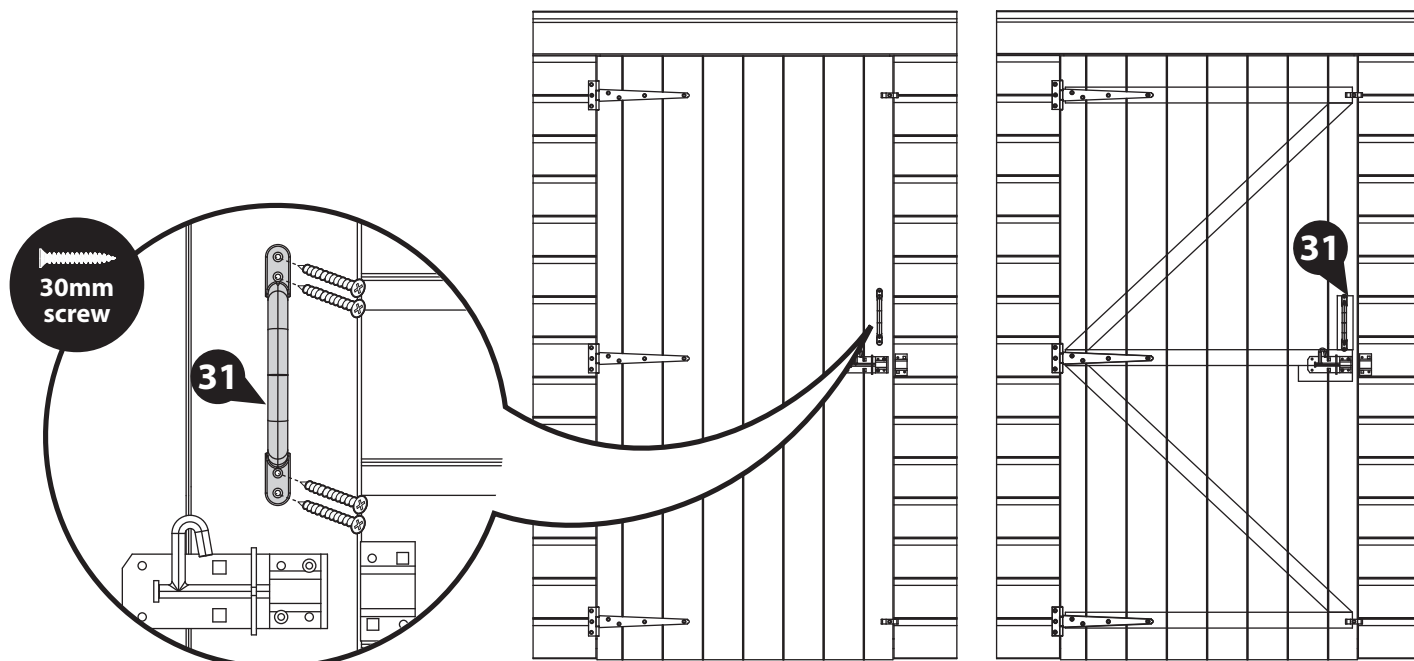

IMPORTANT: Pre-drill before fixing screws.

Step 6

Parts Needed

Building	No. 1	50mm screw
All sizes	QTY 1	QTY 6

Place the Floor Panels (No. 1) face down onto a firm and level base.

Push the Floor Panels together so the bearers are flush and level, as shown.

Secure the Floors together using 6x50mm screws, screwing through the bearers in an alternating pattern.

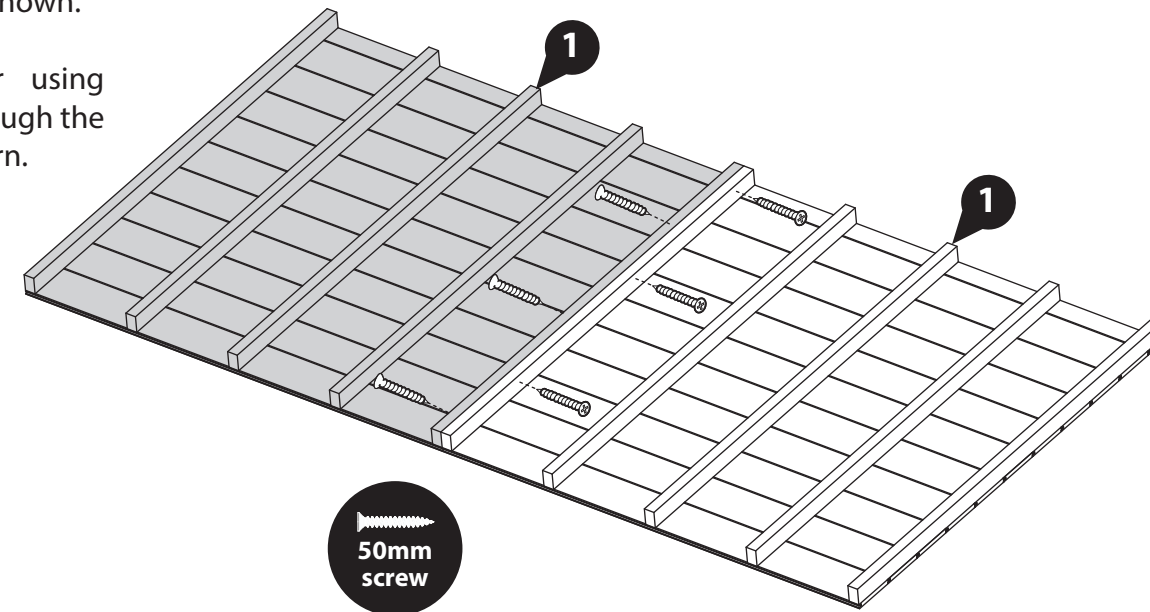

IMPORTANT: Pre-drill before fixing screws.

Step 7

Parts Needed

Building	No. 1	No. 14	60mm screw
All sizes	QTY 1	QTY 2	QTY 10

IMPORTANT: Pre-drill before fixing screws.

Locate the Floor Extension Joists (**No. 14**) onto either end of the assembled Floor Panel, as shown. Ensure the joists are flush to the ends of the Floor framing and with the sides of the Floor Panel.

Secure the joists to the Floor Panel using 5x60mm screws per joist, screwing through the joist into the end of the framing behind.

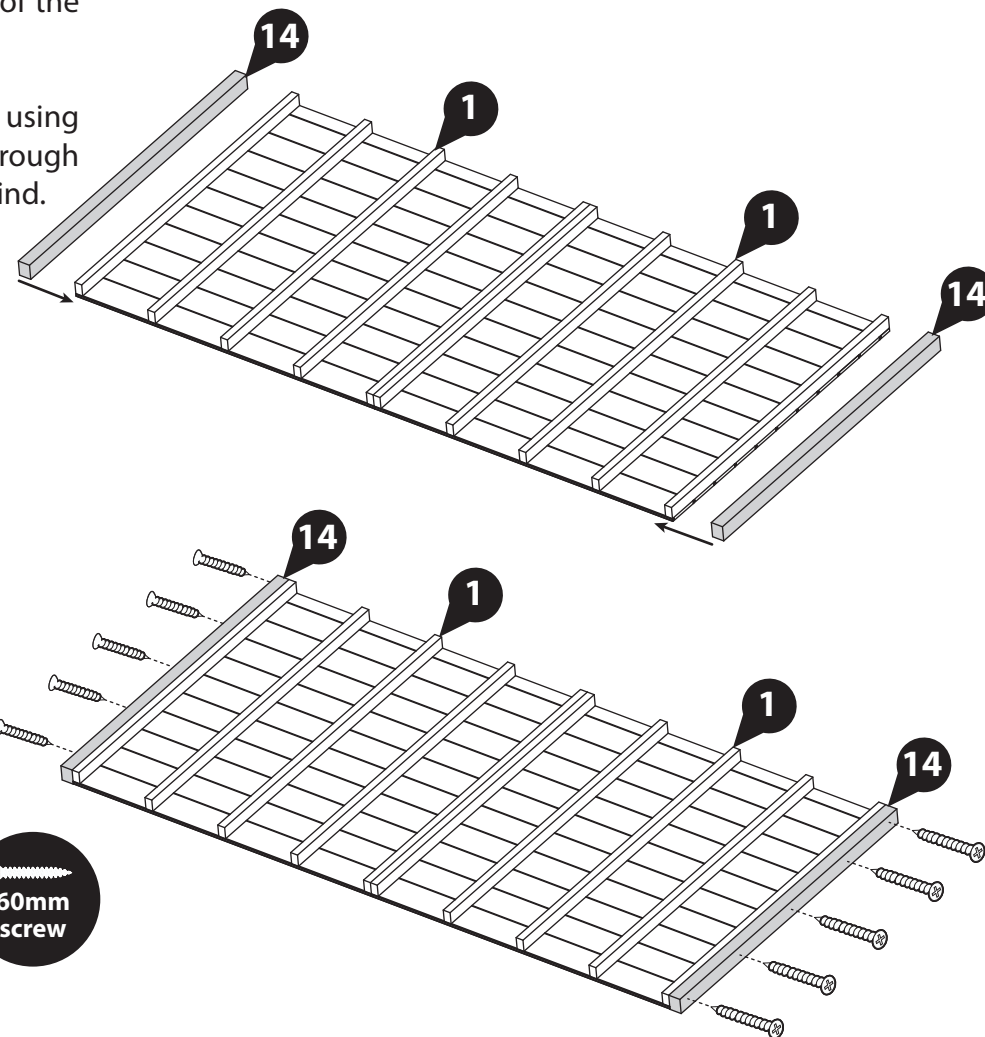

Step 8

IMPORTANT: Pre-drill before fixing screws.

Once assembled, flip the assembled Floor Panel (**No. 1**) over so the bearers are flat on your firm and level base.

Ensure the base has suitable drainage, free from areas where standing water can collect.

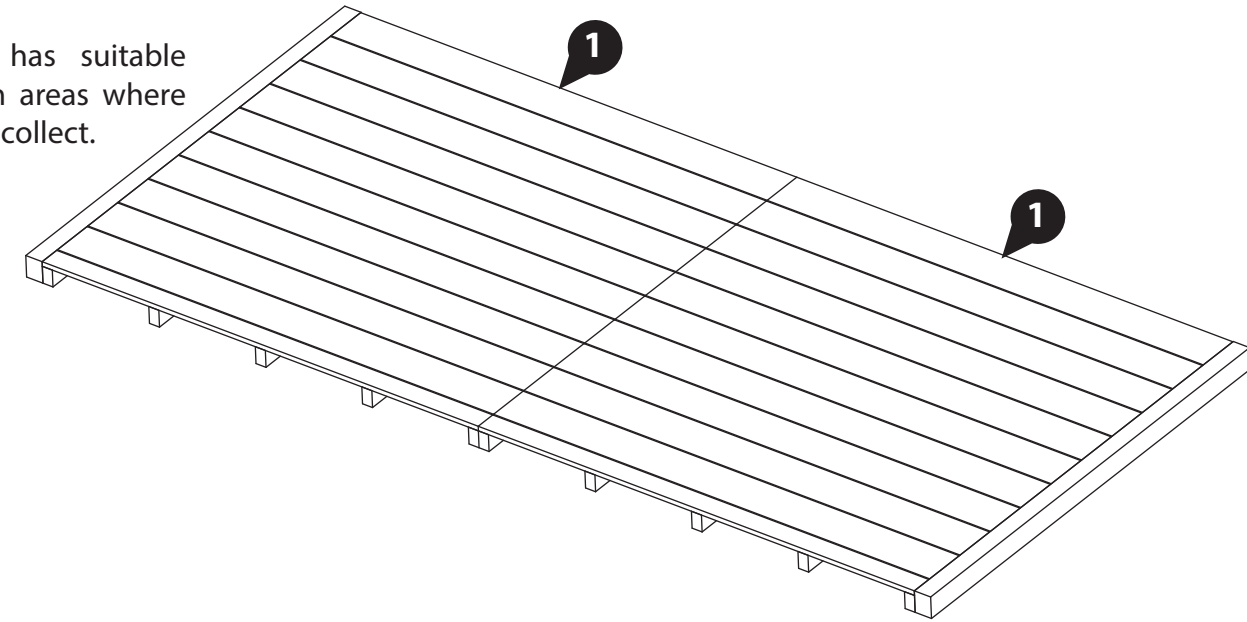

Step 9

Before assembling the shed walls, decide how you want your interchangeable Panels to sit. See Page 5 for some ideas.

It is advised to lay your Panels around the shed floor in the desired positions, an example is shown below.

Please note: the 'Doors on the end' has been shown for illustrative purposes and may differ from your chosen configuration. However, the process of laying out the Panels is the same for all.

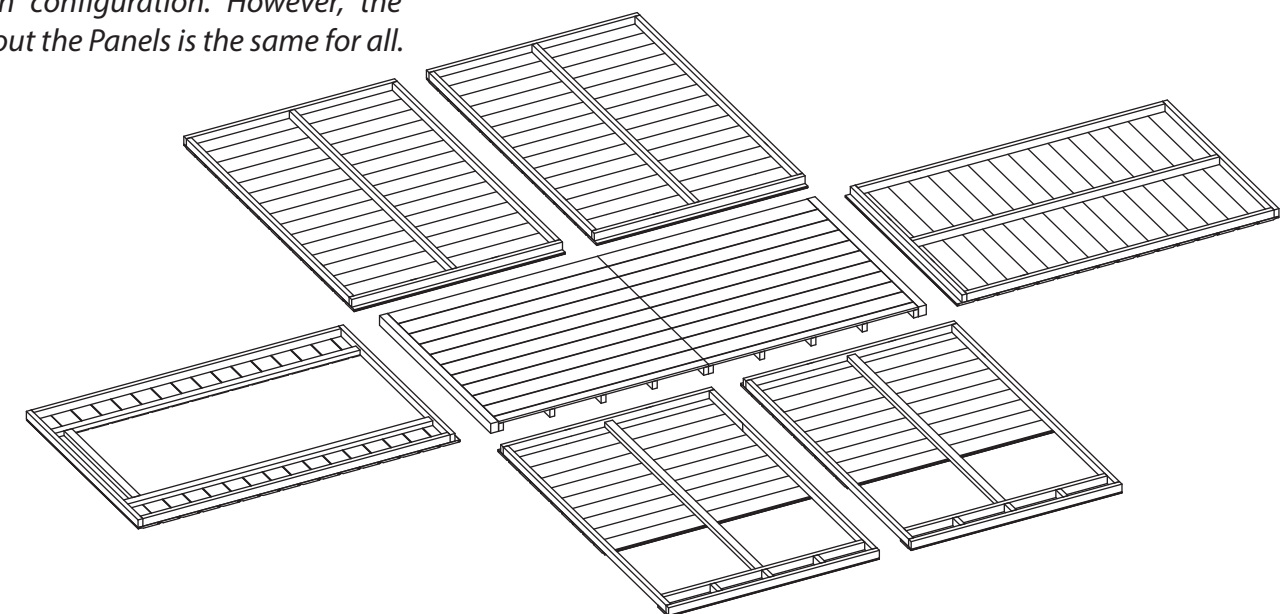

Step 10

Parts Needed

Building	No. 4 (a, b or c)	50mm screw
All sizes	QTY 2	QTY 3

****Please note: The 4ft Panels (No. 4a, 4b and 4c) are all interchangeable and can be positioned in a variety of different configurations. Decide which works best before assembly. See Page 5 for some suggested options.****

Locate a 4ft Panel (No. 4a, 4b or 4c) on top of the Floor Panel at one end.

Locate a 4ft Panel (No. 4a, 4b or 4c) next to the 4ft Panel on the corner, ensuring it sits on the inside of the 4ft Panel on the end, as shown. Externally, the Panel's framing should sit flush and the cladding should sit proud, as shown in the diagram.

Secure the Panels together at the corner using 3x50mm screws, screwing through the side Panel framing into the end Panel framing behind.

Ensure to position the Panels so there is a small gap between the edge of the Floor and the Panel cladding on all sides.

****Please note: If you have purchased a Panel Brace add-on kit, then you may need to secure the panels together higher up to avoid colliding with the brace and screws.**

****Do not secure the building to the Floor until the Roof has been fitted.**

Please note: the 'Doors on the end' has been shown for illustrative purposes and may differ from your chosen configuration. However, the process of fitting the Panels is the same for all.



IMPORTANT: Pre-drill before fixing screws.

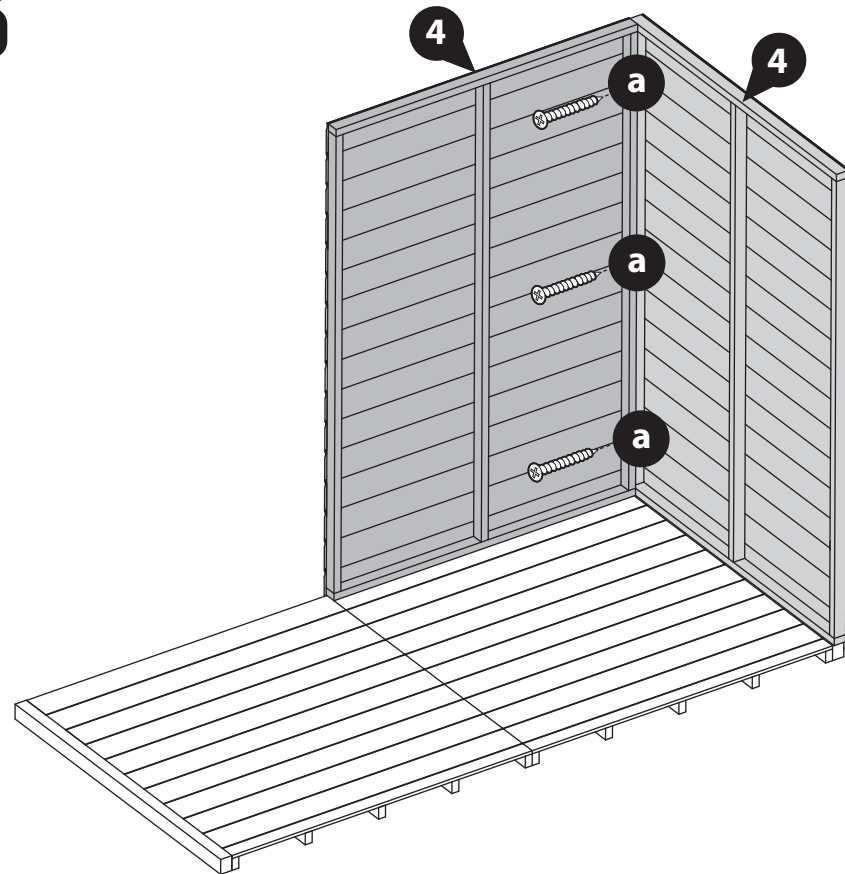

a

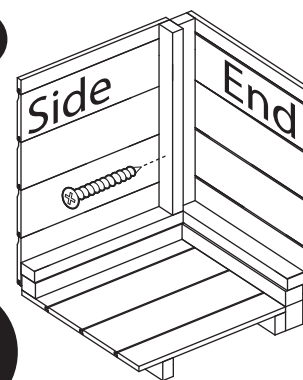

Standard Panels

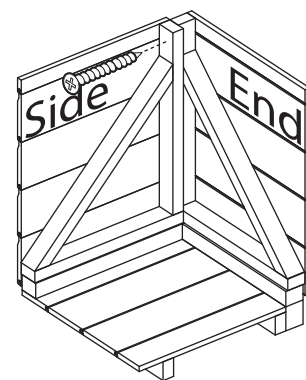

Panel brace kit ONLY

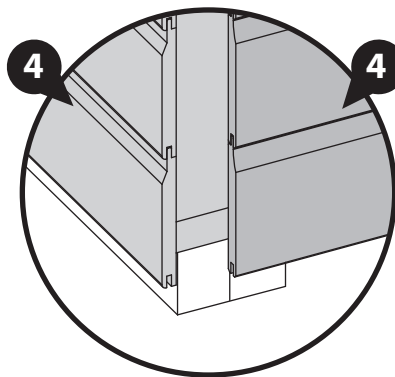

External Corners



Step 11

Parts Needed

Building	No. 4 (a, b or c)	50mm screw
All sizes	QTY 2	QTY 6

Locate a 4ft Panel (No. 4a, 4b or 4c) next to the previously placed 4ft Panel on the side. Secure the Panels together using 3x50mm screws, screwing through the Panel framing.

Locate a 4ft Panel (No. 4a, 4b or 4c) on the opposite corner next to the 4ft Panel, as shown. Externally, the panels framing should sit flush and the cladding should sit proud, as shown in the diagram.

Secure the Panels together at the corner using 3x50mm screws, screwing through the side Panel framing into the end Panel framing behind.

Ensure to position the Panels so there is a small gap between the edge of the Floor and the Panel cladding on all sides.

****Please note: If you have purchased a Panel Brace add-on kit, then you may need to secure the panels together higher up to avoid colliding with the brace and screws.**

****Do not secure the building to the Floor until the Roof has been fitted.**

Please note: the 'Doors on the end' has been shown for illustrative purposes and may differ from your chosen configuration. However, the process of fitting the Panels is the same for all.

IMPORTANT: Pre-drill before fixing screws.

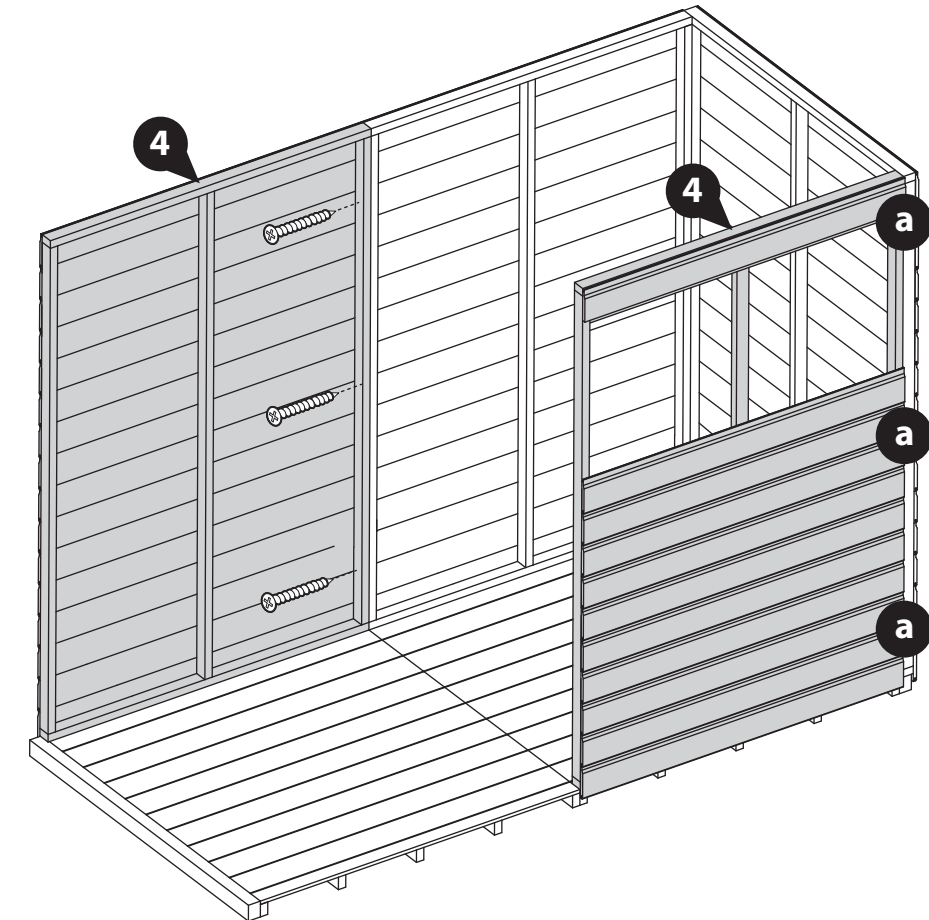

a

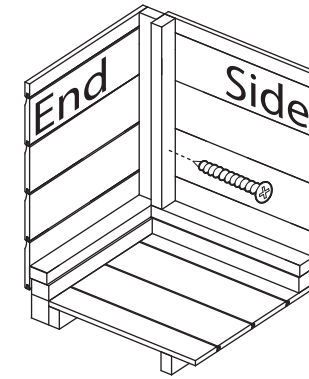

Standard Panels

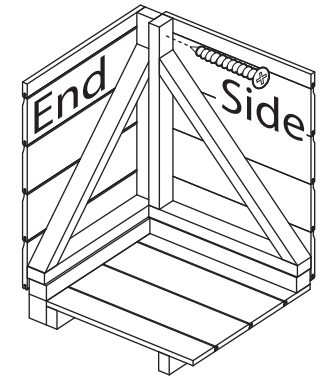

Panel brace kit ONLY

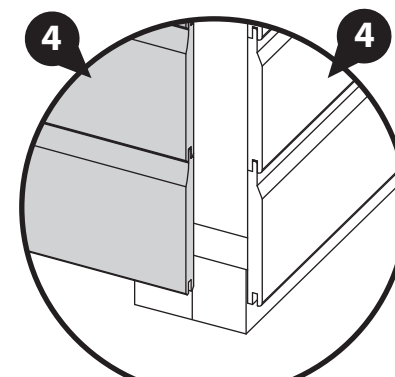

External Corners

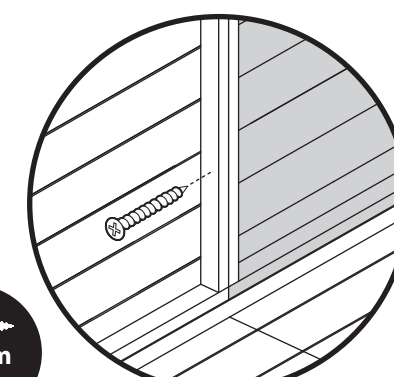

Standard Panels

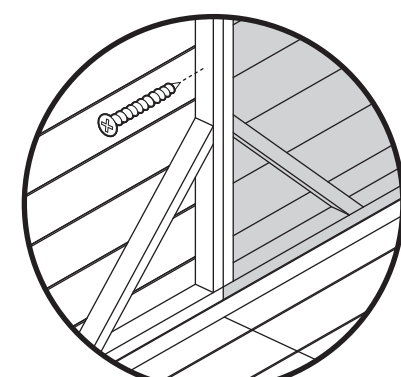

Panel brace kit ONLY

Step 12

Parts Needed

Building	No. 4 (a, b or c)	50mm screw
All sizes	QTY 1	QTY 3

Locate a 4ft Panel (**No. 4a, 4b or 4c**) next to the previously placed Panel.

Secure the Panels together using 3x50mm screws, screwing through the Panel framing.

Ensure to position the Panels so there is a small gap between the edge of the Floor and the Panel cladding on all sides.

****Please note: If you have purchased a Panel Brace add-on kit, then you may need to secure the panels together higher up to avoid colliding with the brace and screws.**

****Do not secure the building to the Floor until the Roof has been fitted.**

Please note: the 'Doors on the end' has been shown for illustrative purposes and may differ from your chosen configuration. However, the process of fitting the Panels is the same for all.

IMPORTANT: Pre-drill before fixing screws.

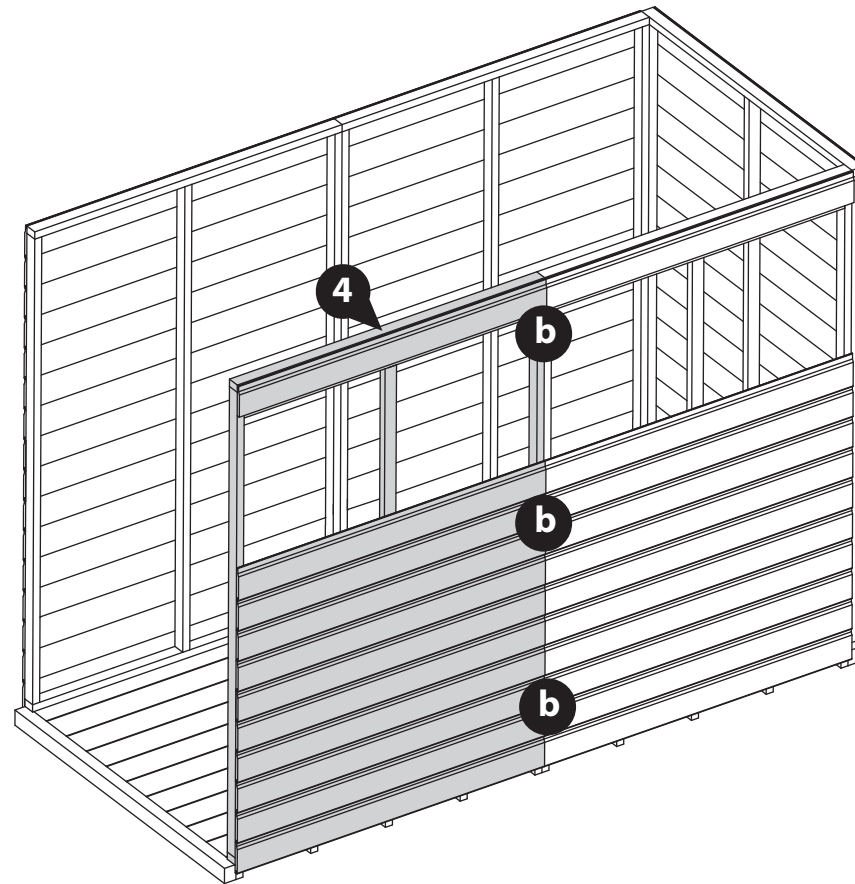

Step 13

Parts Needed

Building	No. 4 (a, b or c)	50mm screw
All sizes	QTY 1	QTY 6

Locate the remaining 4ft Panel (**No. 4a, 4b or 4c**) on top of the Floor at the end, ensuring it sits on the outside of the previously placed Panels, as shown.

Externally, the Panels framing should sit flush and the cladding should sit proud, as shown in the diagram.

Secure the Panels together at the corners using 3x50mm screws per corner, screwing through the adjacent Panel framing into the Panel framing behind.

Position the Panels so there is a small gap of equal distance between the edge of the Floor and the Panel cladding on all sides. This allows for the buildings natural movement over time.

****Please note: If you have purchased a Panel Brace add-on kit, then you may need to secure the panels together higher up to avoid colliding with the brace and screws.**

****Do not secure the building to the Floor until the Roof has been fitted.**

Please note: the 'Doors on the end' has been shown for illustrative purposes and may differ from your chosen configuration. However, the process of fitting the Panels is the same for all.

IMPORTANT: Pre-drill before fixing screws.

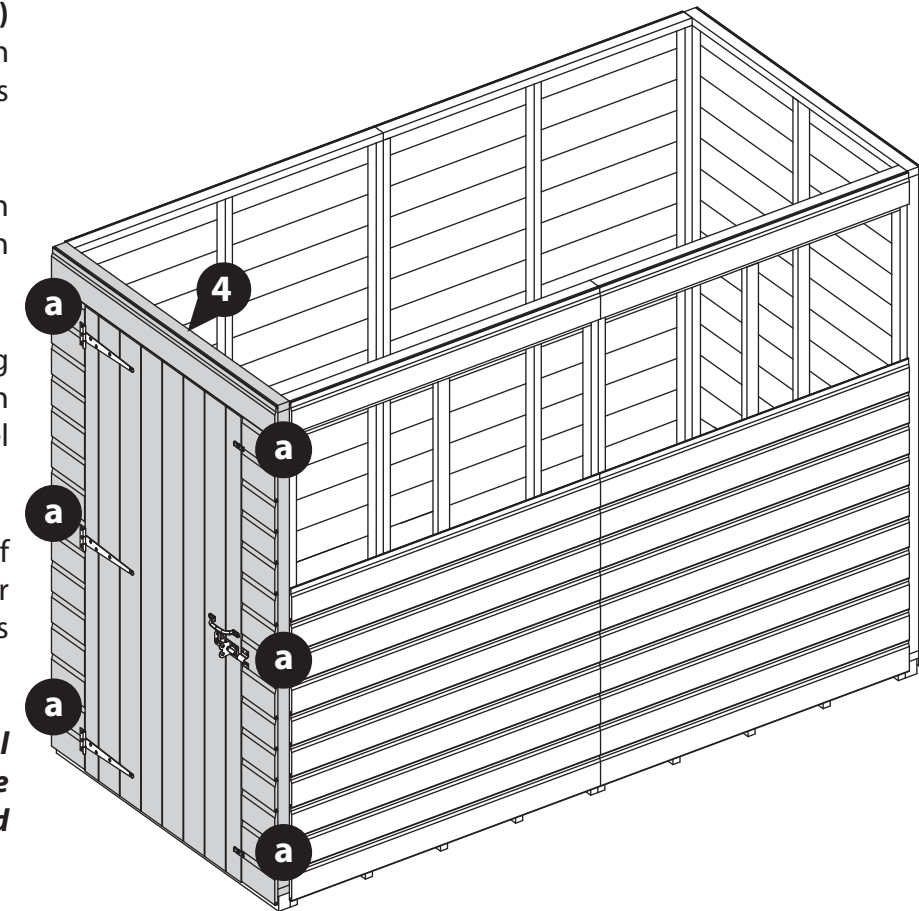

b

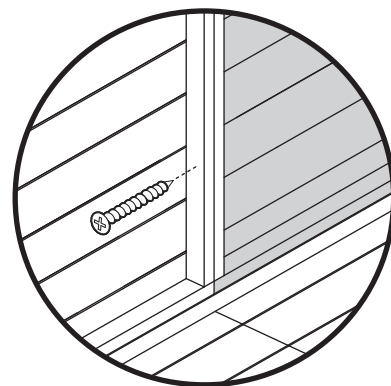

Standard Panels

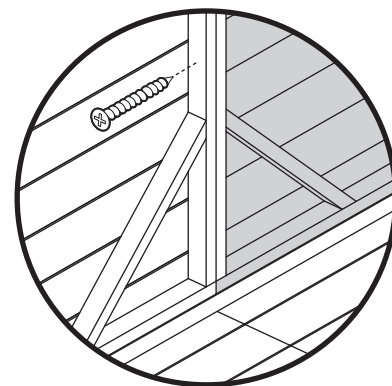

Panel brace kit ONLY



50mm screw



a

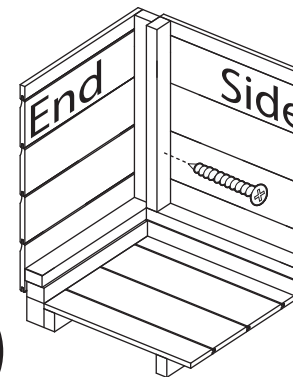

Standard Panels



50mm screw

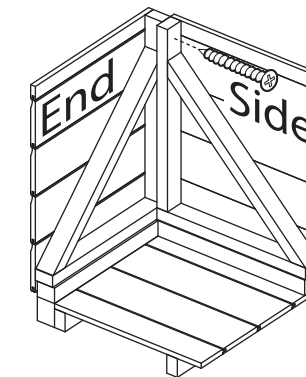

Panel brace kit ONLY

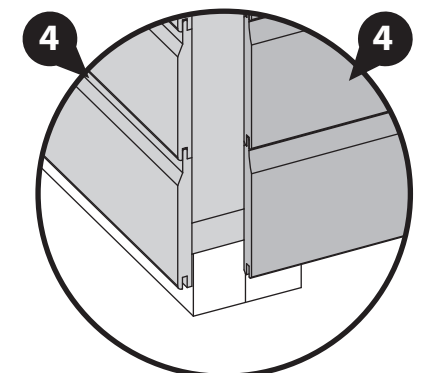

External Corners

Step 14

Parts Needed

Building	No. 6	No. 7	50mm screw
All sizes	QTY 1	QTY 1	QTY 8

Locate one Left and Right Gable Top (**No. 6 & 7**) on top of the end Panels, ensuring that the Gable cladding slots into the top cladding on the Panel below.

Secure in place using 4x50mm screws per Gable, screwing up through the Panel framing into the Gable.

Please note: the 'Doors on the end' has been shown for illustrative purposes and may differ from your chosen configuration. However, the process of fitting the Gable Tops is the same for all.

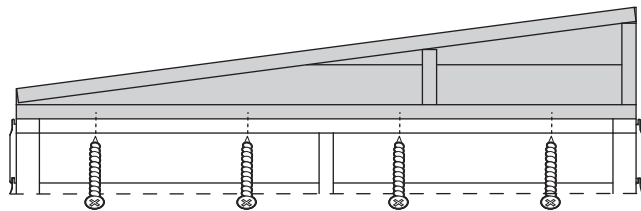

IMPORTANT: Pre-drill before fixing screws.

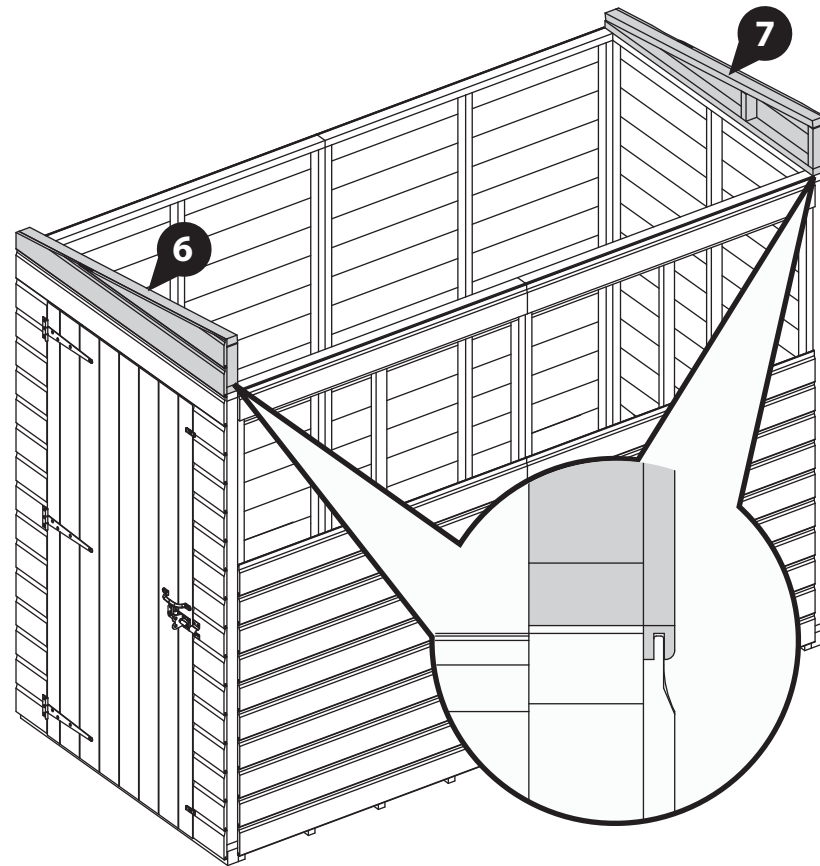

Step 15

Parts Needed

Building	No. 5	50mm screw
All sizes	QTY 2	QTY 11

a Locate one of the 4ft Toppers (**No. 5**) on top of one of the 4ft side Panels, at the tallest end of the Gables, as shown.

Ensure that the Topper cladding slots into the top cladding on the Panel below.

Secure in place using 4x50mm screws, screwing up through the Panel framing into the Topper framing.

b Locate the 4ft Topper (**No. 5**) on top of the remaining 4ft side Panel, at the tallest end of the Gables, as shown.

Ensure that the Topper cladding slots into the top cladding on the Panel below.

Secure in place using 4x50mm screws, screwing up through the Panel framing into the Topper framing.

Please note: The Toppers will sit slightly lower than the top of the Gable tops.

c Ensuring the two Toppers (**No. 5**) are flush and level, secure them together and to the Gables using 3x50mm screws.

Please note: the 'Doors on the end' has been shown for illustrative purposes and may differ from your chosen configuration. However, the process of fitting the Toppers is the same for all.

IMPORTANT: Pre-drill before fixing screws.

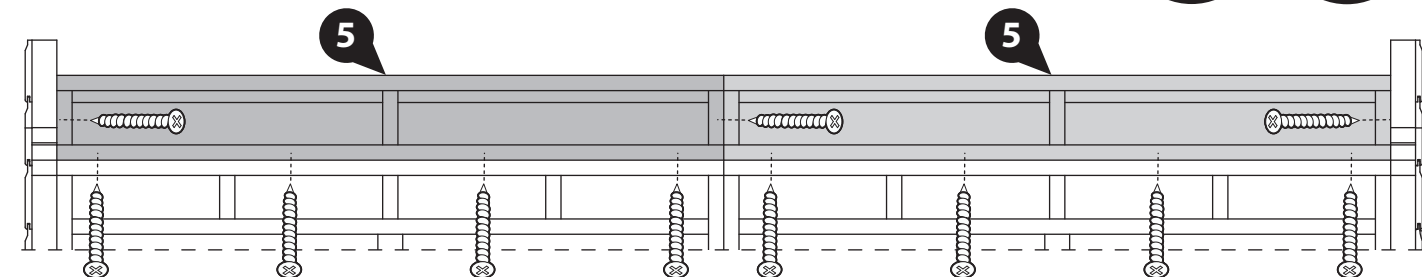
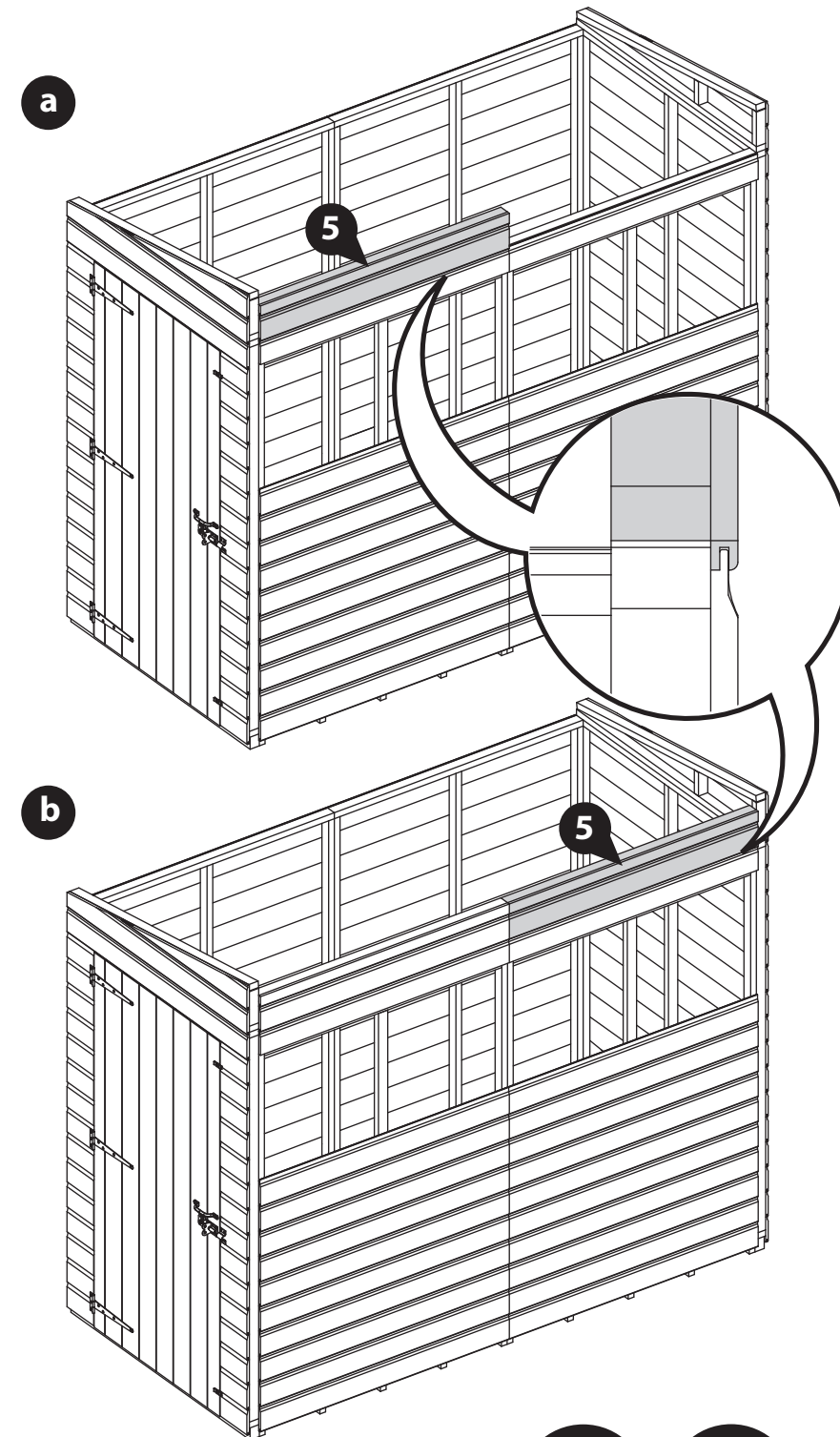

Step 16 **Parts Needed**
Building **No. 3** **50mm screw**
All sizes **QTY 2** **QTY 12**

IMPORTANT: Pre-drill before fixing screws.

a Locate one 4ft Shed Roof (**No. 3**) on top of the building, ensuring the Panel sits inside the Gable Top and is in line with the 4ft side Panel, as shown.

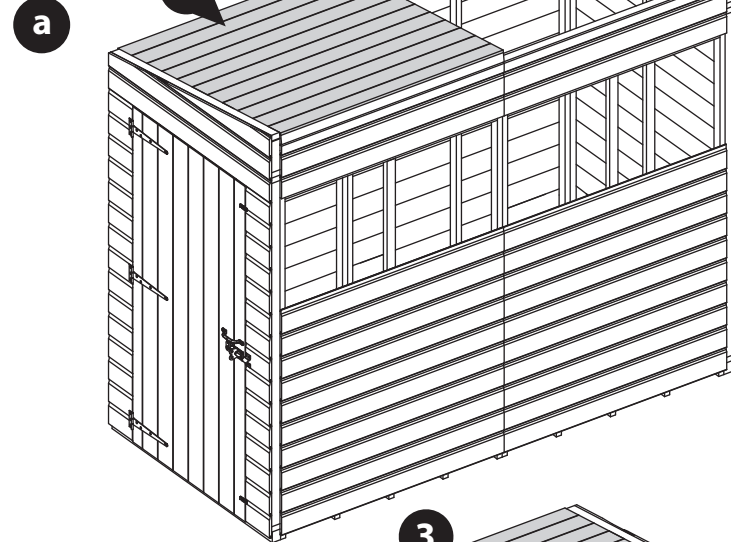

b Locate the remaining 4ft Roof (**No. 3**) on top of the building, ensuring the Panel sits inside the Gable Top, is in line with the 4ft side Panel and is flush and level with the 4ft Roof, as shown.

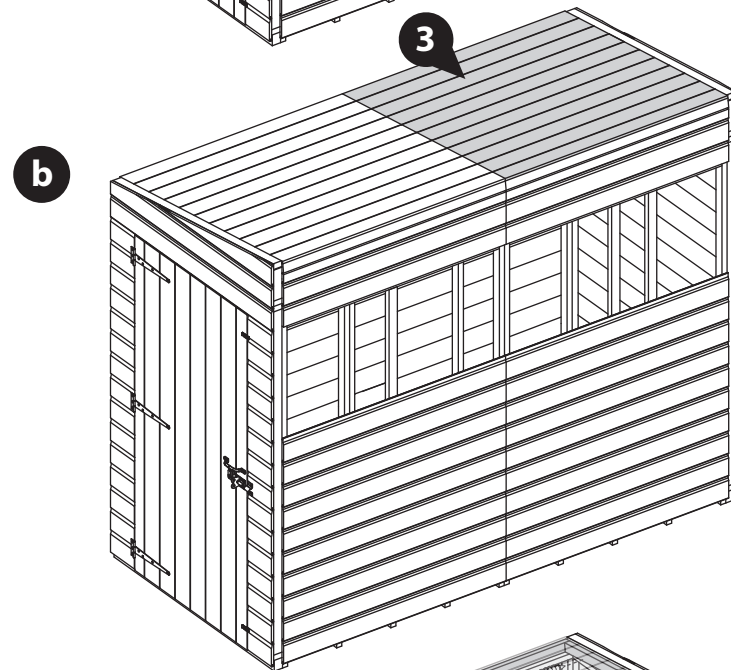

Secure the two Roofs (**No. 3**) together using 6x50mm screws, screwing through the framing in an alternating pattern.

c Once secured together, position the Roofs so that the cladding of the Toppers (**No. 5**) aligns with the edge of the Roof Panel framing, as shown.

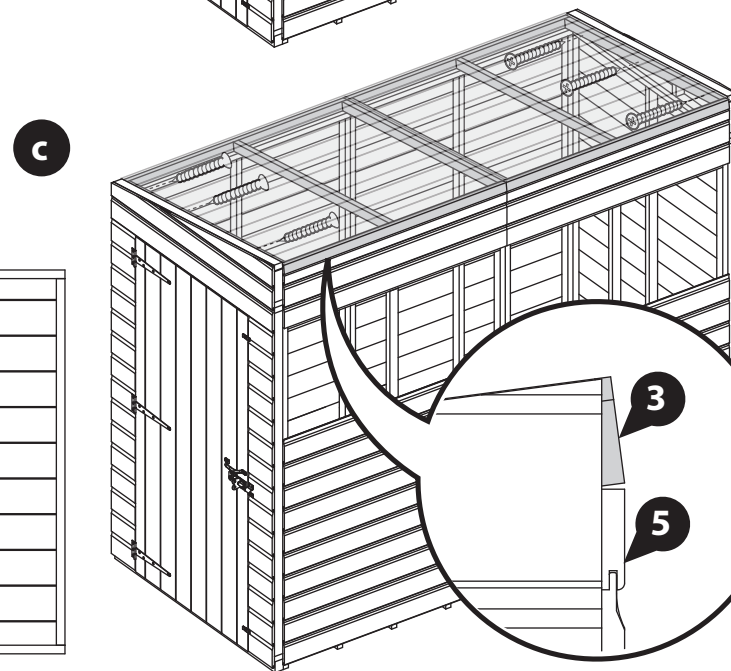

Secure the Roof Panels to the Gable Tops using 3x50mm screws per Roof, screwing through the Panel framing into the Gable behind.

Please note: the 'Doors on the end' has been shown for illustrative purposes and may differ from your chosen configuration. However, the process of fitting the Roofs is the same for all.



Internal view of underside

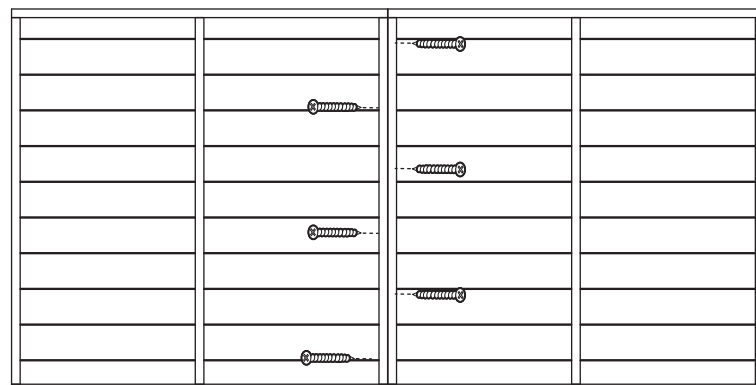

Step 17 **Parts Needed**
Building **50mm screw**
All sizes **QTY 12**

IMPORTANT: Pre-drill before fixing screws.

Make sure the building is square by measuring from corner to corner and comparing the measurements. If the measurements are equal, the building is square, if not, adjustments may be required.

Once square, secure the Roofs (**No. 3**) in place by screwing up through the wall panel framing into the Roof Panel framing at the front and back of the building using 6x50mm screws per Roof Panel.

Please note: the 'Doors on the end' has been shown for illustrative purposes and may differ from your chosen configuration. However, the process of fixing the Roofs is the same for all.

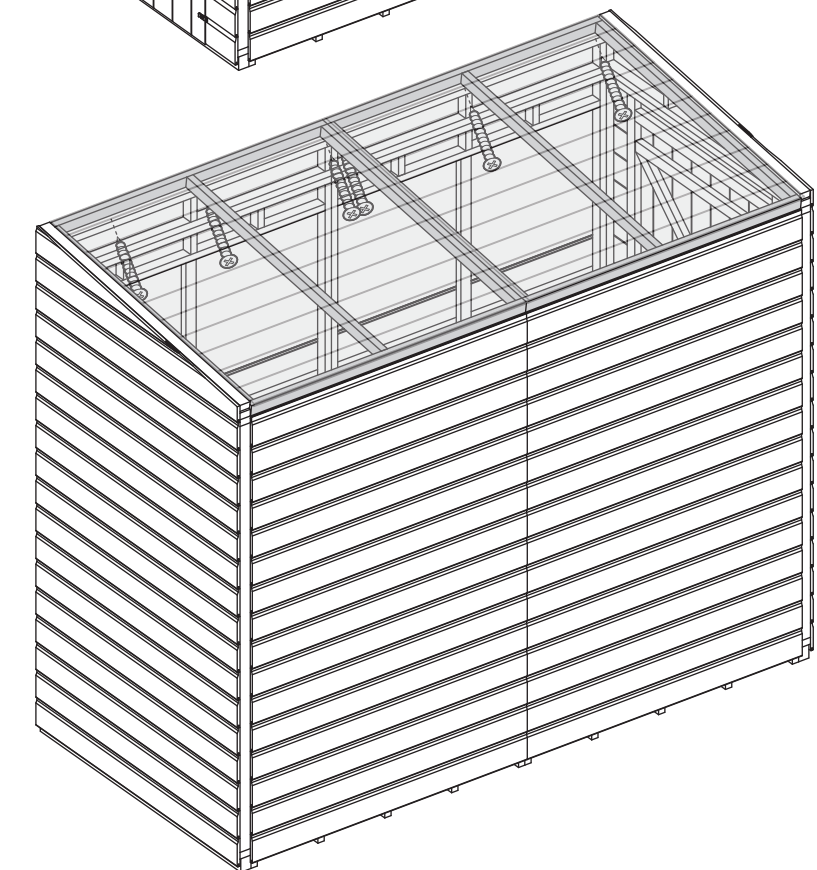
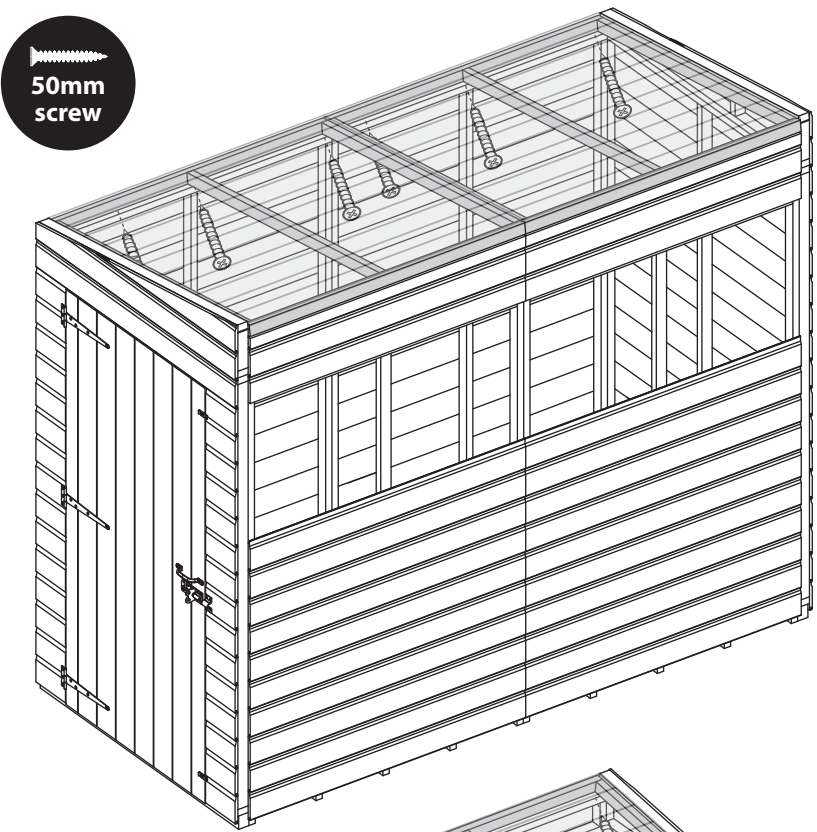

Step 18 Parts Needed

Building	50mm screw
All sizes	QTY 20

Once the Roof is fixed, secure the Panels to the Floor using 50mm screws, screwing down through the Panel framing into the Floor bearers below.

****Please note: If you have purchased a panel brace kit, when fixing near an angled brace, you may need to screw through the Panel framing at an angle to ensure they are in line with the Floor bearers.**

Please note: the 'Doors on the end' has been shown for illustrative purposes and may differ from your chosen configuration. However, the process of fixing the panels is the same for all.

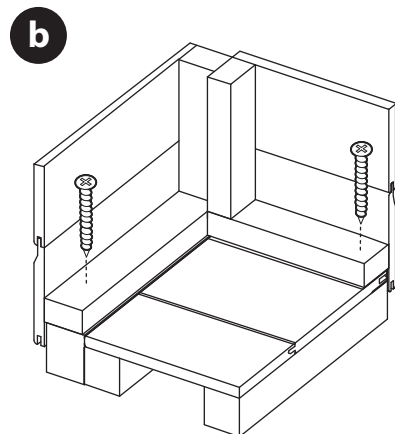
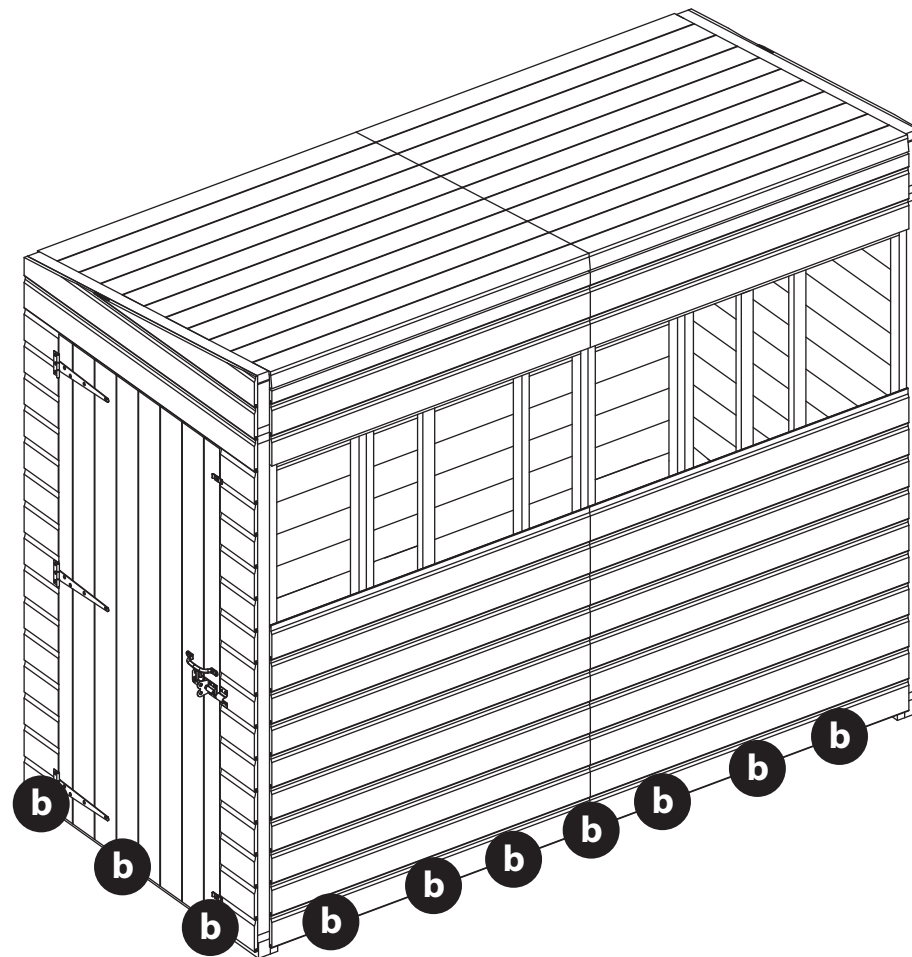

Standard Panels

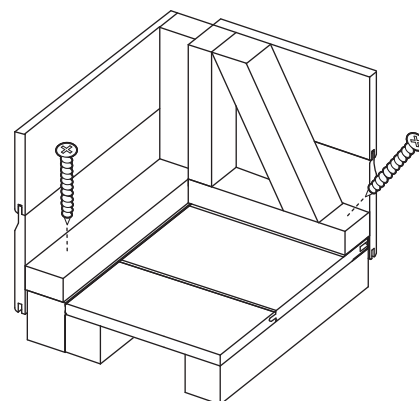

Panel brace kit ONLY



IMPORTANT: Pre-drill before fixing screws.

Step 19 Parts Needed

Building	No. 20	No. 21	No. 34	No. 35	30mm screw
All sizes	QTY 2	QTY 10	QTY 2	QTY 4	QTY 42

a Inside the 4ft Window Panel (**No. 4a**) opening, locate one Window Strip (**No. 21**) to either side of the outer window framing exposed in the window gap, as shown. Secure in place using 3x30mm screws per Strip.

b Place the Plastic Window Cill (**No. 34**) onto the 4ft Window Panel (**No. 4a**) opening, as shown. Ensure the cill sits on top of the cladding and flush to the central upright. Secure in place using 3x30mm screws, screwing through the cill into the framing behind.

c Position the Styrene sheets (**No. 35**) on top of the Plastic Window Cill (**No. 34**), ensuring they are equally spaced in the window openings.

For added weather protection, use a sealant application gun to apply a neat line of Clear Silicone around the outside edges of the Styrene.

****Silicone sealant not provided.**

d Position the remaining three Window Strips (**No. 21**) on top of the cill on either side of the Styrene and the centre. Place the Top Window Strip (**No. 20**) above the previously placed strips, along the top of the window opening.

Secure in place using 3x30mm screws per strip. Ensure to screw through the strips into the framing behind, not the Styrene.

Repeat this process (A-D) to fix the strips, cill, styrene sheets and sealant into both Window Panels.

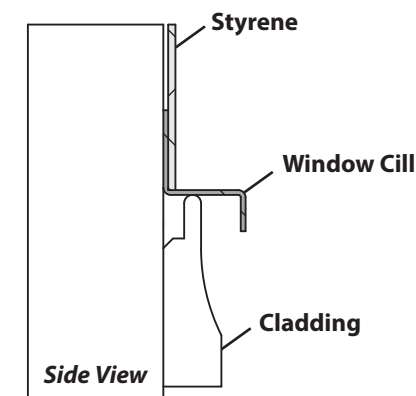

IMPORTANT: Pre-drill before fixing screws.

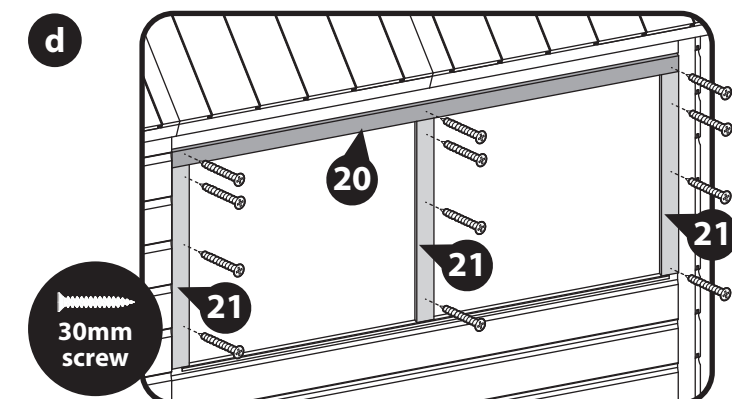
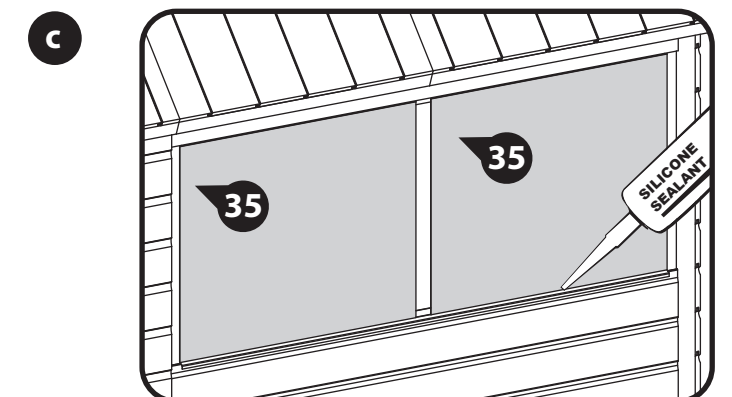
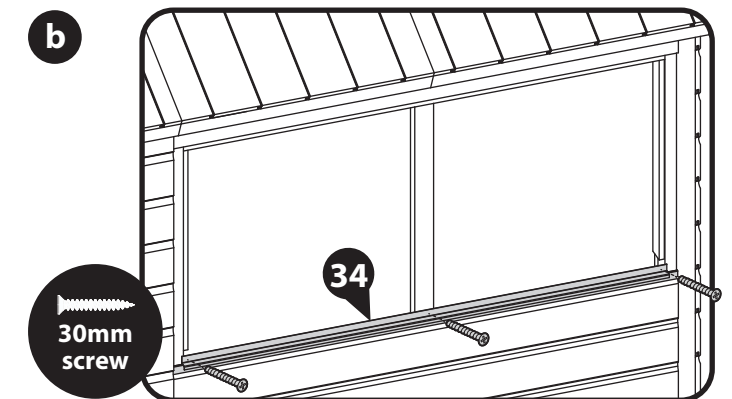
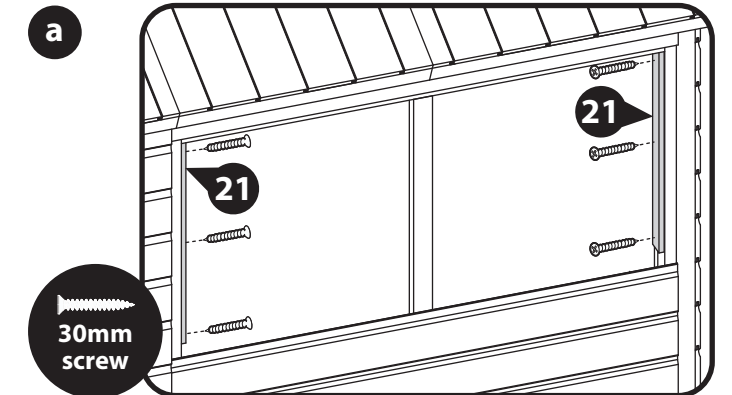

IMPORTANT: Pre-drill before fixing screws.

Step 20	Parts Needed	
Building	No. 23	50mm screw
All sizes	QTY 2	QTY 6

a Along the lower side of the building, use a tape measure to measure the distance from one end to the other (Gable top to Gable top), as shown.

b Lay two Eaves Frames (**No. 23**) out end-to-end so they are flush and level, and mark this total measurement onto the framing, as shown.

Use a saw to remove the excess framing.

c Locate the Eaves Frames (**No. 23**) onto the lower side of the building, ensuring that the framing is flush to the top of the roof panels and ends of the Gables, as shown.

Secure in place using 3x50mm screws per Eaves Frame.

***DO NOT fit any Eaves Framing on the tallest side of your shed. Fitting this will obstruct the assembly of your Greenhouse side.**

Please note: the 'Doors on the end' has been shown for illustrative purposes and may differ from your chosen configuration. However, the process of fitting the Eaves Frames is the same for all.

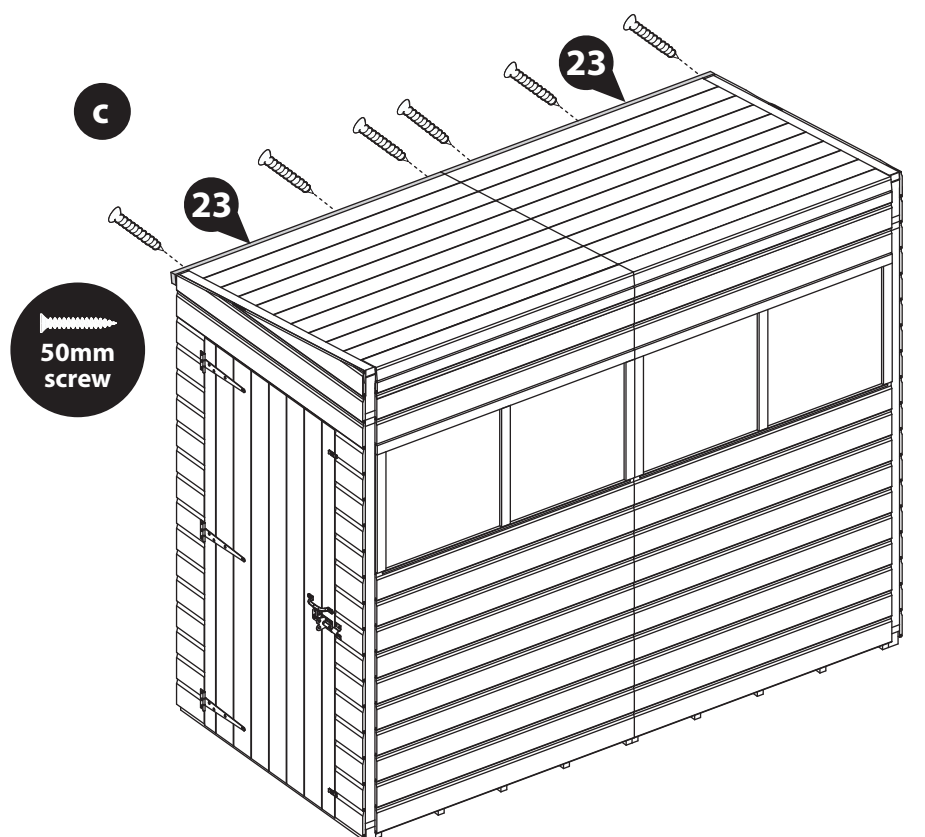
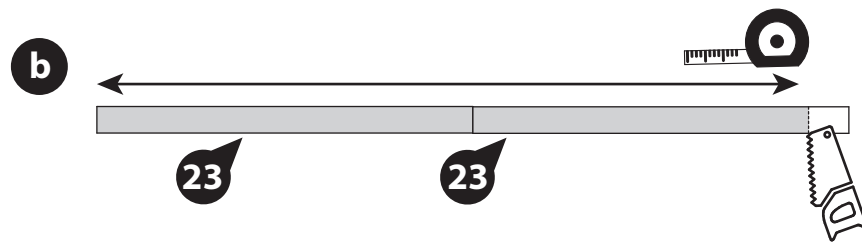
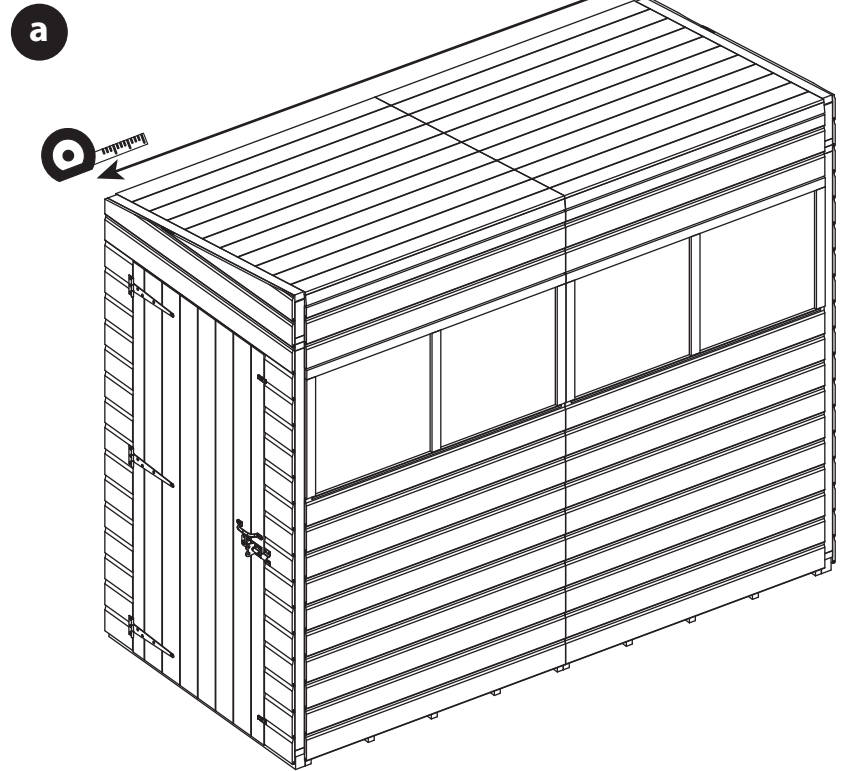

Step 21	Parts Needed	
Building	No. 23	50mm screw
All sizes	QTY 2	QTY 6

a At either end of the building, use a tape measure to measure the total distance from front to back, as shown.

Mark the measurements onto two Eaves Frames (**No. 23**) and cut to size.

b Locate the cut down Eaves Frames (**No. 23**) on to the front of the Gable Tops on either end of the building, ensuring that the framing is flush to the top of the Gable as well as the back Eaves Frames, as shown.

The end Eaves Frames (**No. 23**) should sit on the outside of the back Eaves Frames (**No. 23**), as shown.

Secure in place using 3x50mm screws per Eaves Frame.

Please note: the 'Doors on the end' has been shown for illustrative purposes and may differ from your chosen configuration. However, the process of fitting the Eaves Frames is the same for all.



IMPORTANT: Pre-drill before fixing screws.

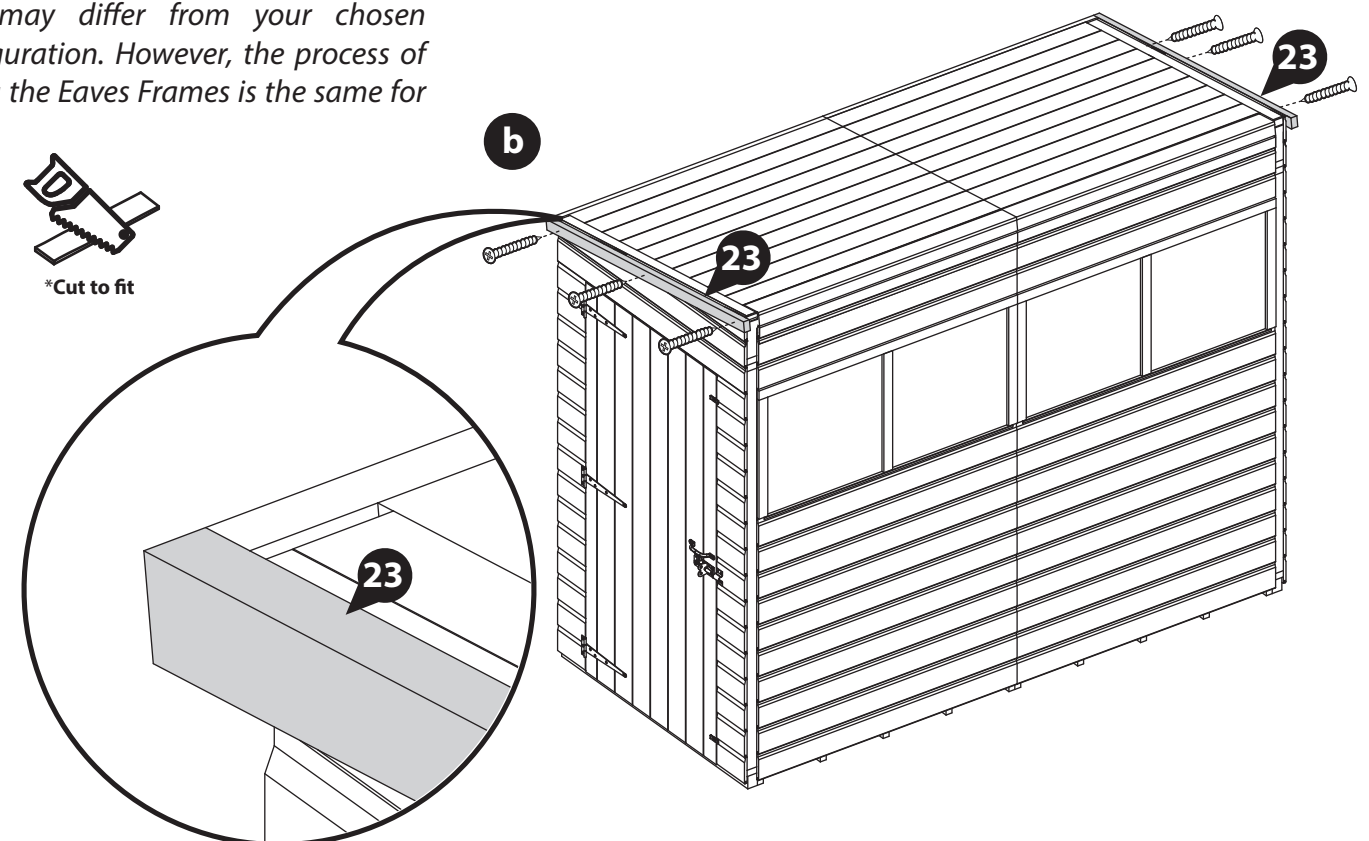
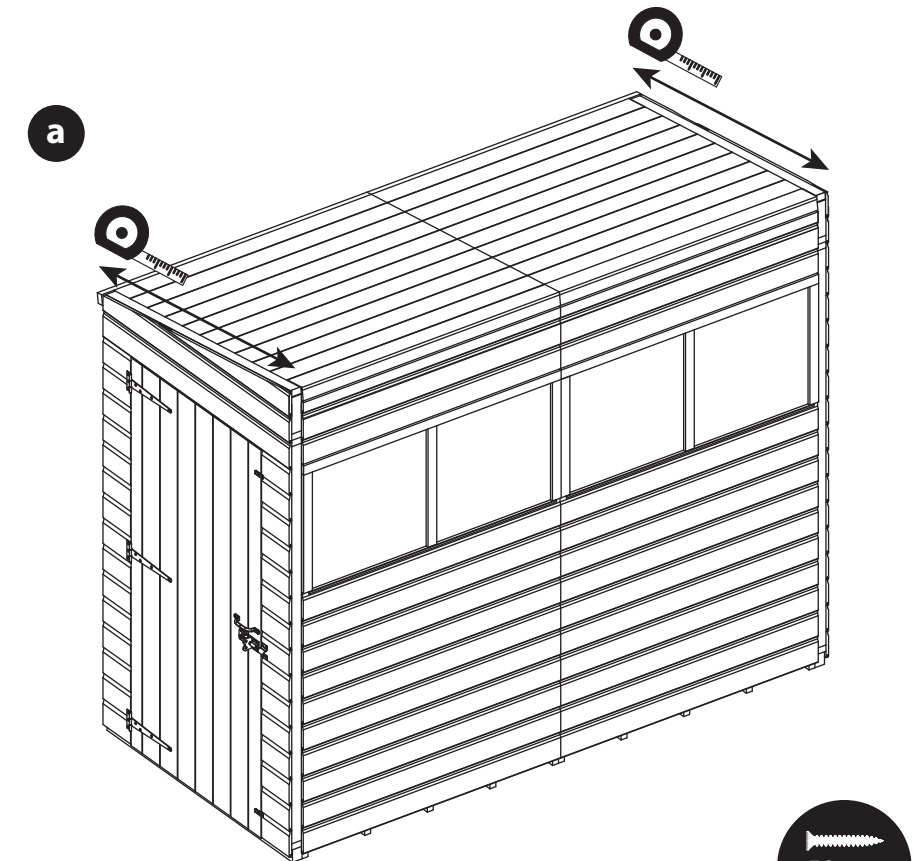

Step 22 Parts Needed

Building	No. 36	Felt Tacks
All sizes	QTY 4	QTY 100

a Cut the Felt (**No. 36**) into two sheets measuring: **2650mm (L) x 1000mm (W)**.

Lay the sheets onto the roof in the order shown in the diagram, ensuring there is a 50mm overhang around the sides and that each sheet overlaps by 100mm.

b Secure the felt in place by hammering felt tacks into the overlapping layers, the front, back and sides of the building at 100mm intervals, as shown.

Ensure to fold the corners of the Felt over each other to create a neat finish, as shown.

Please note: the 'Doors on the end' has been shown for illustrative purposes and may differ from your chosen configuration. However, the process of fitting the Felt is the same for all.

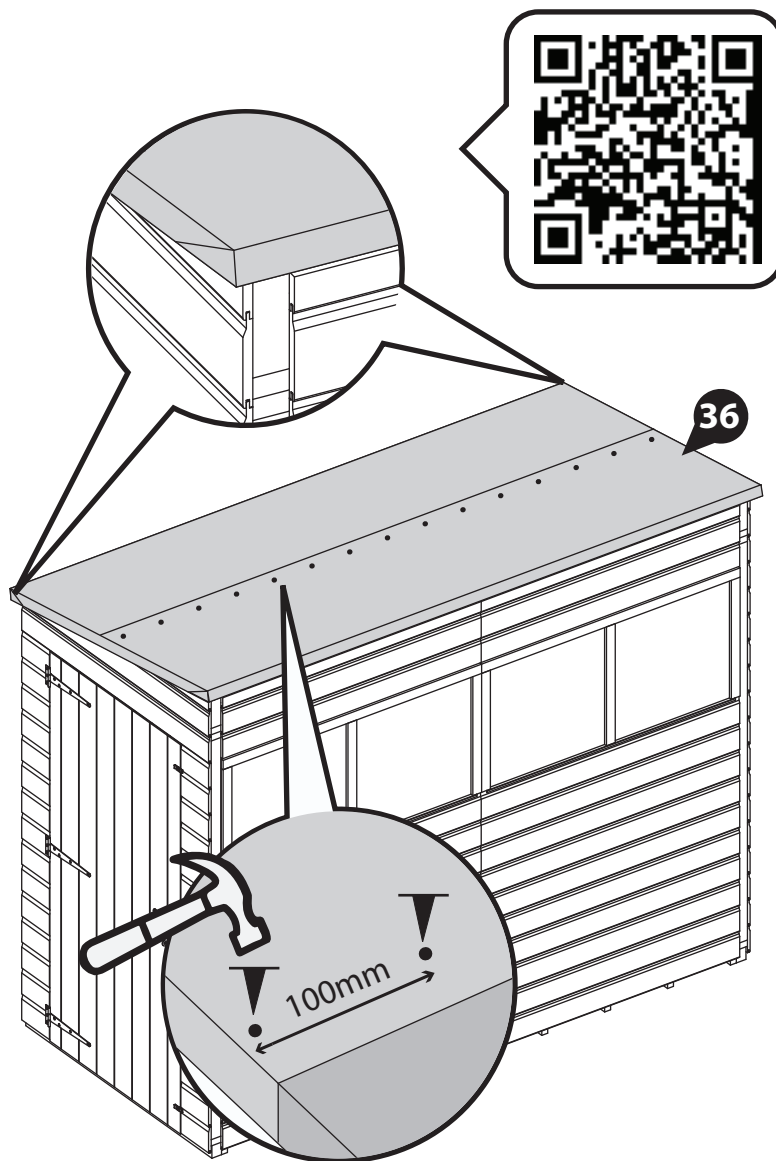
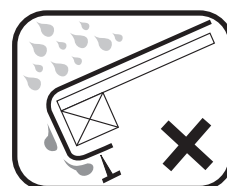
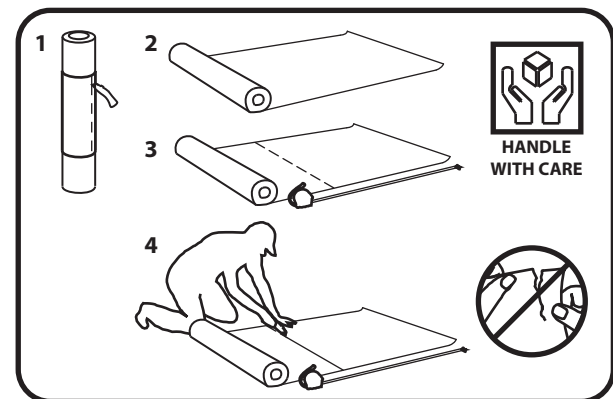
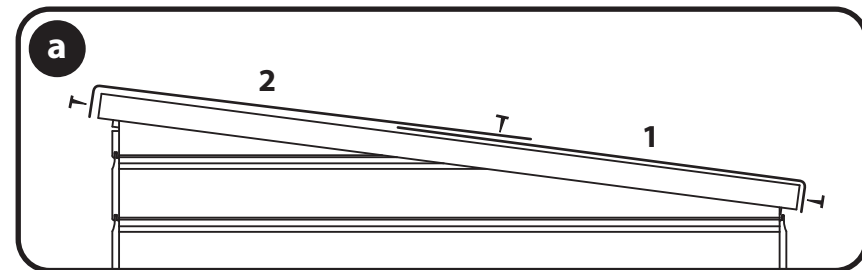

Step 23 Parts Needed

Building	No. 24	30mm screws
All sizes	QTY 5	QTY 15

a At each corner and Panel join, use a tape measure to measure the distance from the bottom of the Panel to the underside of the Roof framing, as shown.

Mark the measurements onto the Cover Trims (**No. 24**), and cut to size.

b Locate the cut down Cover Trims (**No. 24**), over each Panel join and corner, ensuring they sit centrally over the joins and flush to the Panel cladding at the corners.

Secure in place using 3x30mm screws per Cover Trim, alternating fixing into each Panel when over a join.

***Please DO NOT fit the central cover trim over the joining panels on the tallest side of your shed. Fitting this will obstruct the assembly of your Greenhouse side.**

Please note: the 'Doors on the end' has been shown for illustrative purposes and may differ from your chosen configuration. However, the process of fitting the Cover Trims is the same for all.



IMPORTANT: Pre-drill before fixing screws.

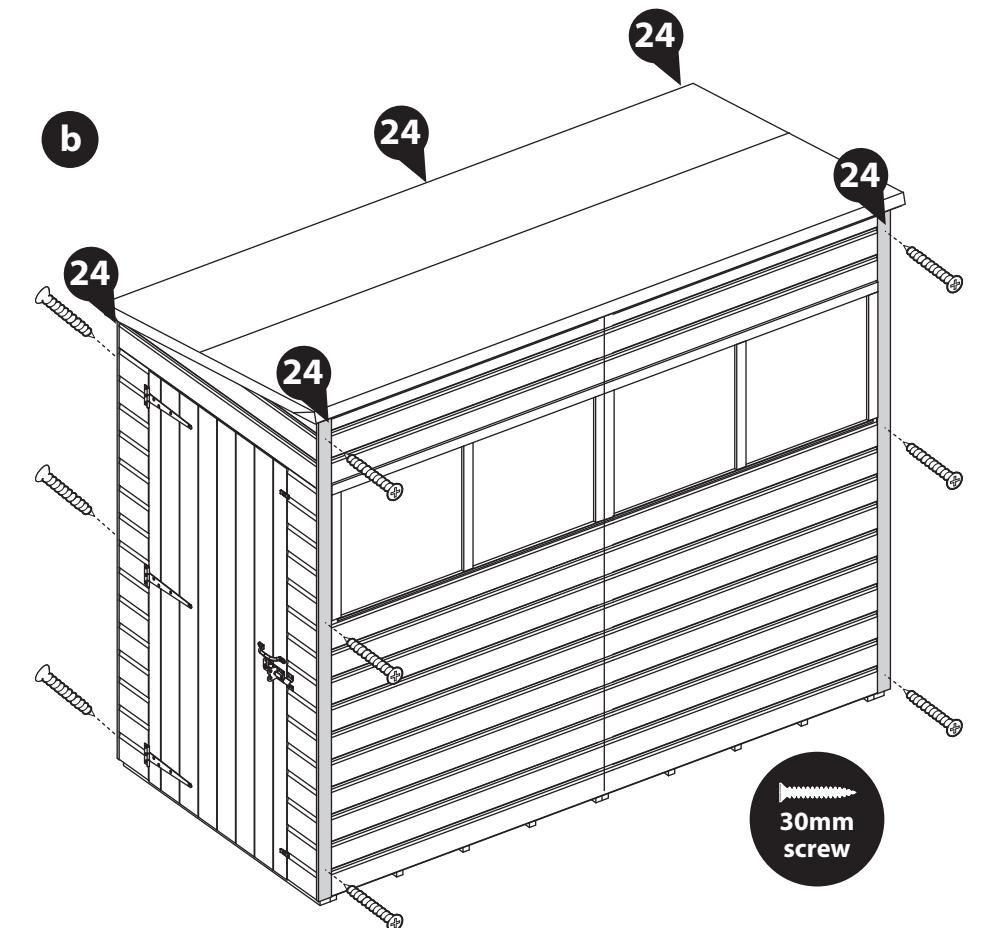
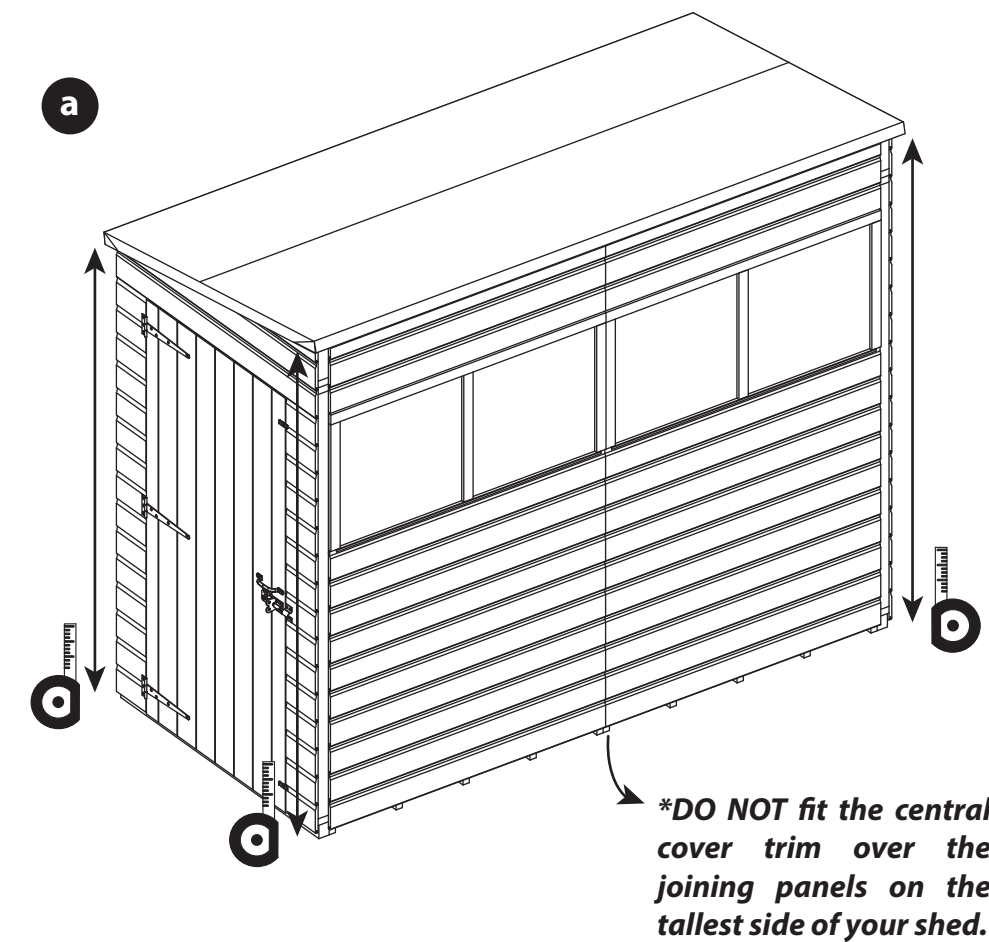

Step 24

Parts Needed

Building	No. 8a	No. 10	No. 39	30mm black screw
All sizes	QTY 1	QTY 1	QTY 3	QTY 27

a Lay the 2ft Single Door Panel (No. 8a) face up on a flat and level surface.

To ensure the panel is the correct way up, check that the internal lips on either side of the upright framing are visible.

b Place the Door (No. 10) within the Door Panel opening so it is sat on the internal lipped edges.

Ensure there is equal spacing on all sides and that the cut outs on the Door are lined up with the cut out in the door frame.

Locate the Greenhouse T-Hinges (No. 39) onto the Door and Door Panel, ensuring the Hinges line up with the Door framing.

Secure in place using 9x30mm black screws per hinge.



IMPORTANT: Pre-drill before fixing screws.

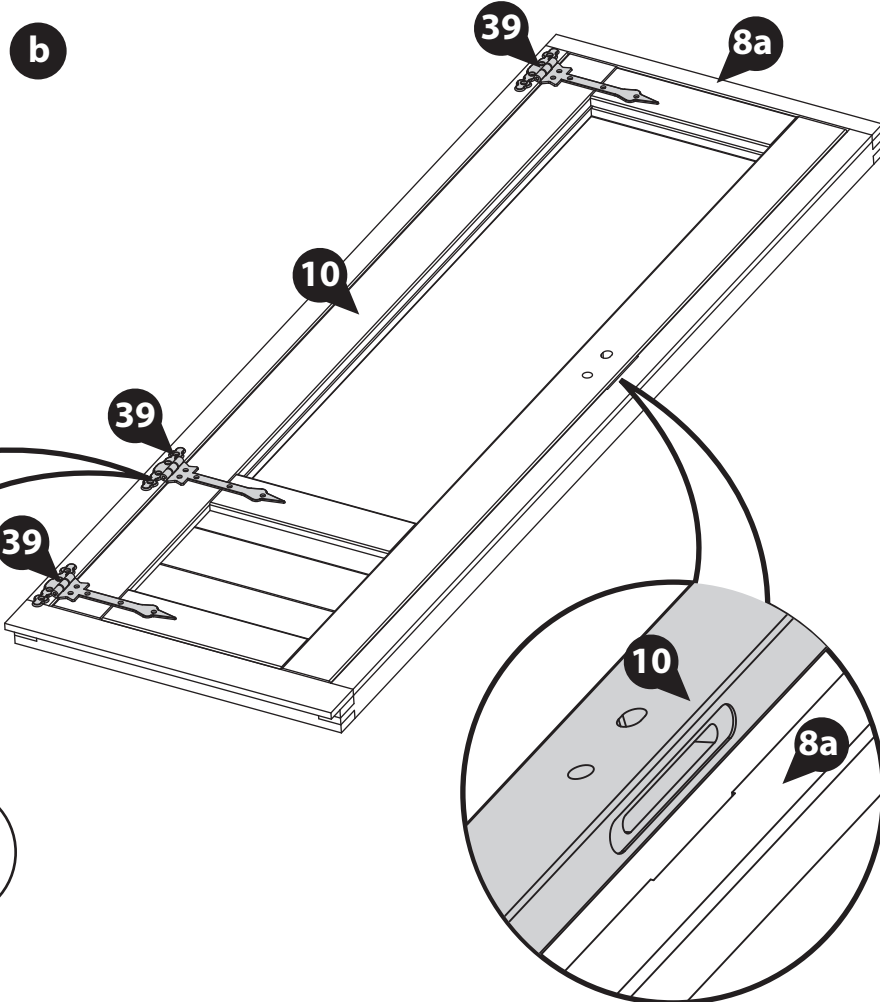
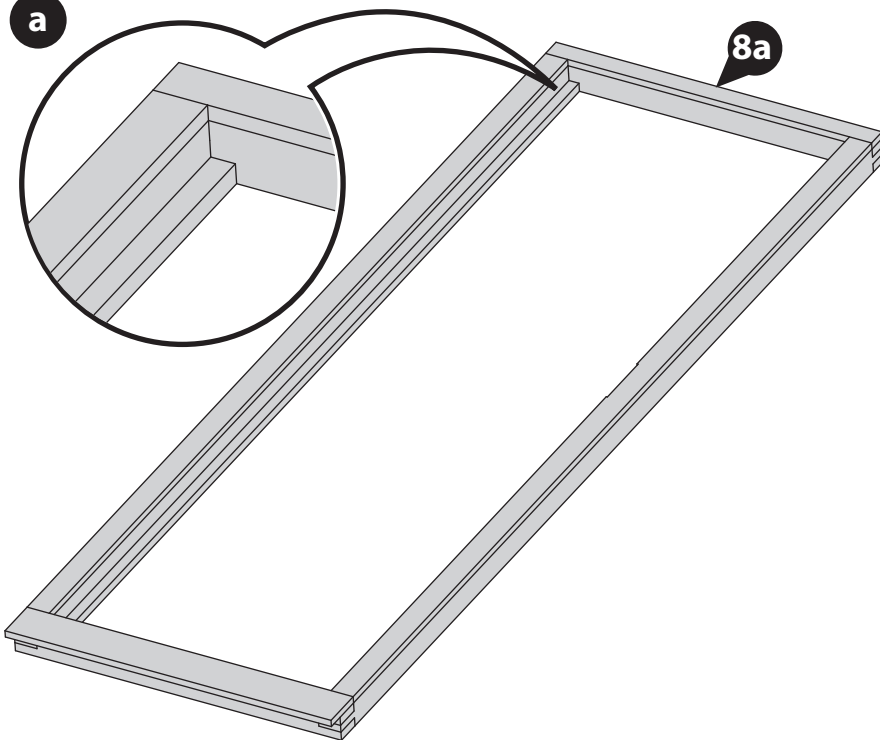

Step 25

Parts Needed

Building	No. 40	No. 41	30mm screw
All sizes	QTY 1	QTY 1	QTY 4

Open the Door and locate the Lock (No. 40) into the recess of the Door (No. 10). Fix in place using 2x30mm screws.

Locate the Key-Plate (No. 41) onto the recess on the inside of the Door Panel (No. 8a). Fix in place using 2x30mm screws.

Do NOT shut the door fully until the Handle Set has been fitted in step 26.

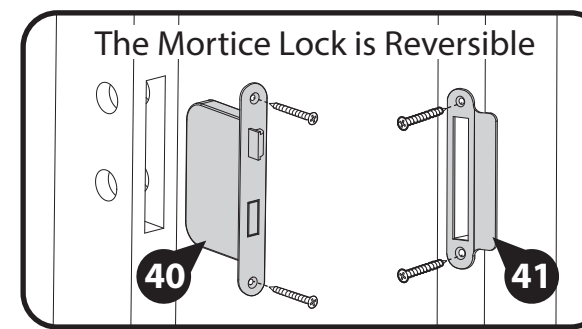

IMPORTANT: Pre-drill before fixing screws.

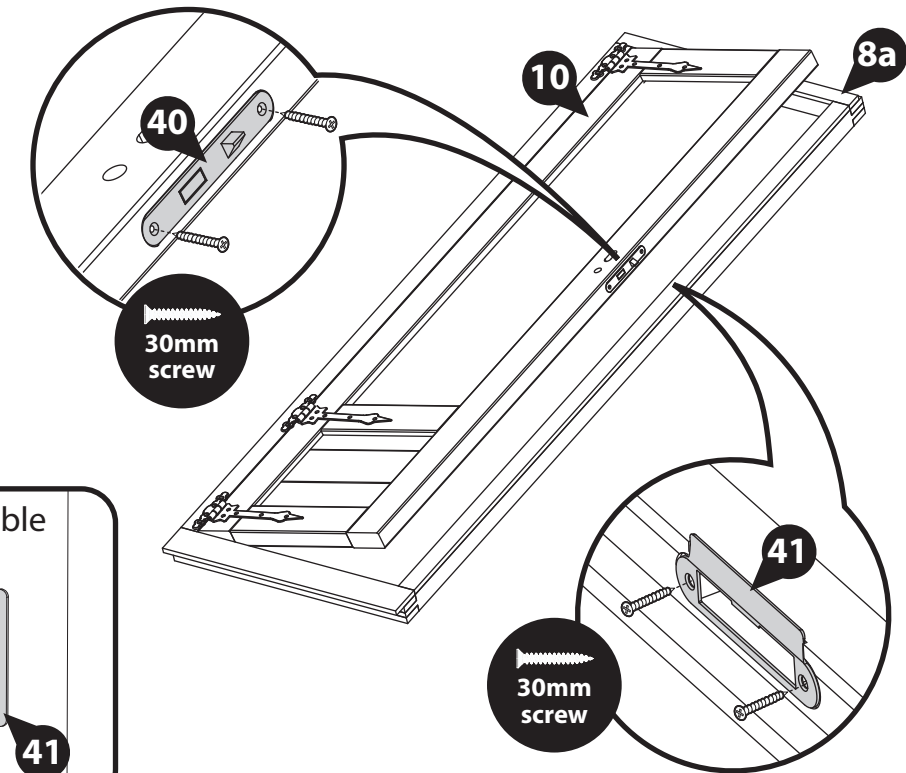

Step 26

Parts Needed

Building	No. 42	30mm black screw
All sizes	QTY 1	QTY 8

From the Handle Set (No. 42) position the Metal Bar through the Door and lock and connect one handle onto either side, as shown.

Fix each Handle in place using 4x30mm black screws.

Before closing the door, ensure the door mechanism works by checking that the lock (No. 40) moves with the Handle set.

Then, check the door can open and close freely.



IMPORTANT: Pre-drill before fixing screws.

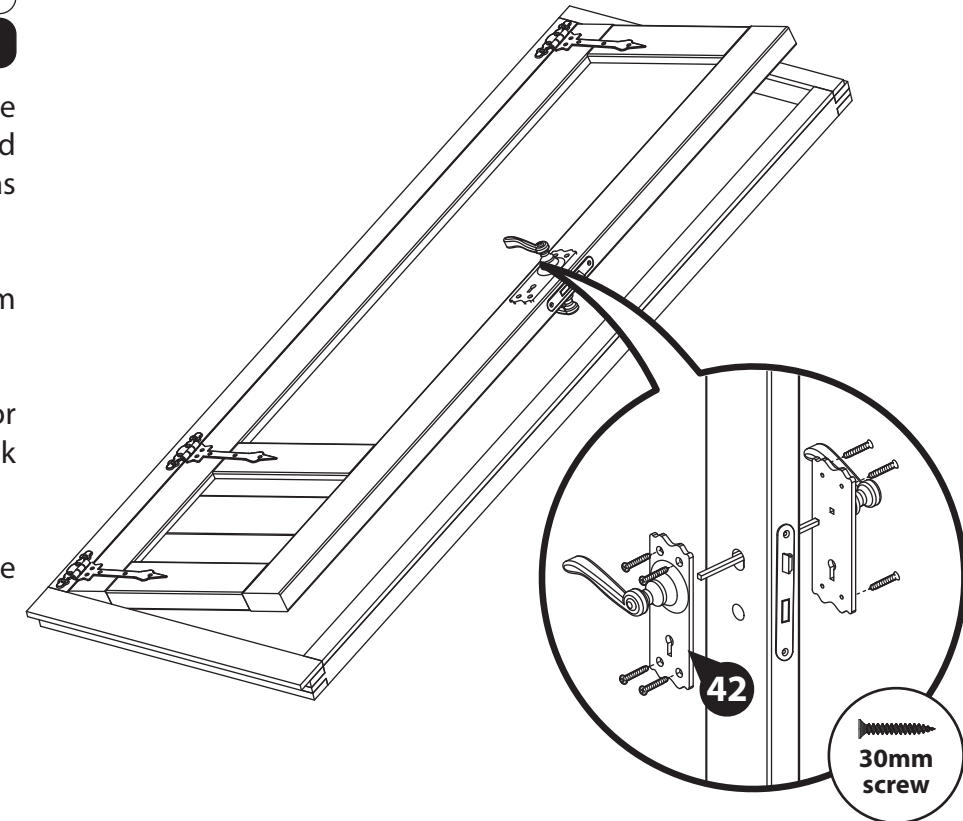

Step 27

Please refer to your 'Base frame construction' manual to assemble your 8ft combi base frame.

It is essential to complete the steps explained in this additional guide before continuing the construction of your building.

Please note: the 8x8 'Doors on the end' has been shown for illustrative purposes and may differ from your chosen configuration. However, the process of assembling the Base Frame is the same for all.

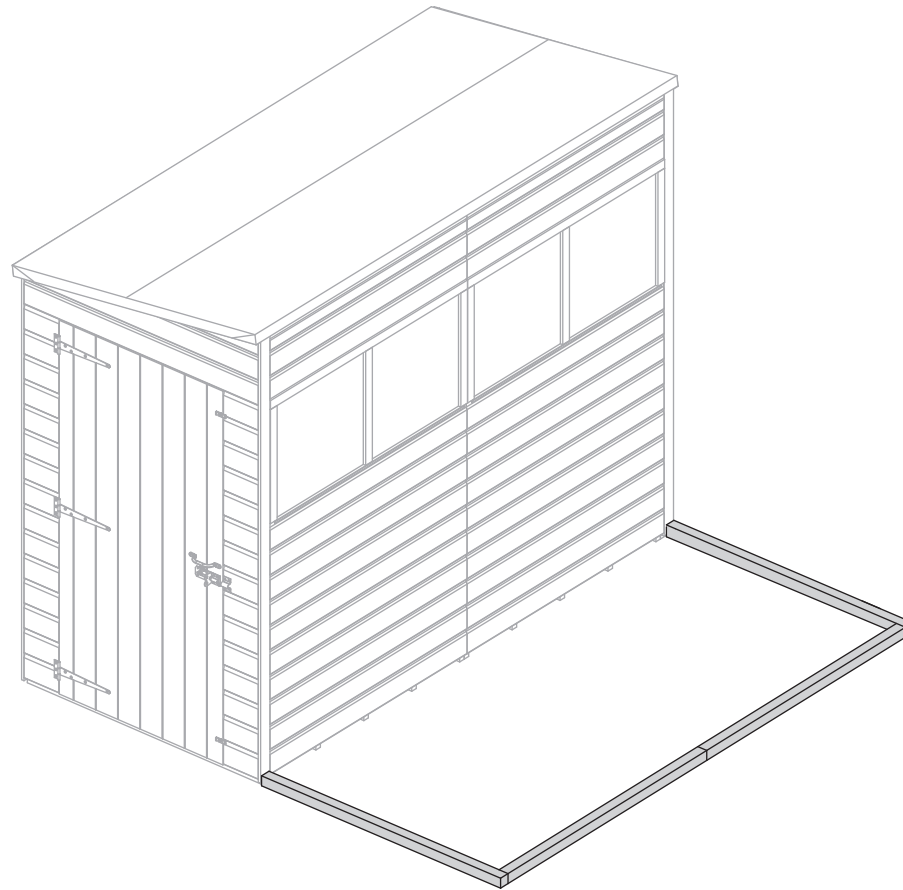

Step 28

With your base constructed, decide how you want your interchangeable panels to sit.

If you have not yet assembled your base framing, please refer to the 'Base frame construction' manual provided with your building.

It is advised to lay your panels around the base frame in the desired positions, an example is shown below.

Please note: the 8x8 'Doors on the end' has been shown for illustrative purposes and may differ from your chosen configuration. However, the process of laying out the panels is the same for all.

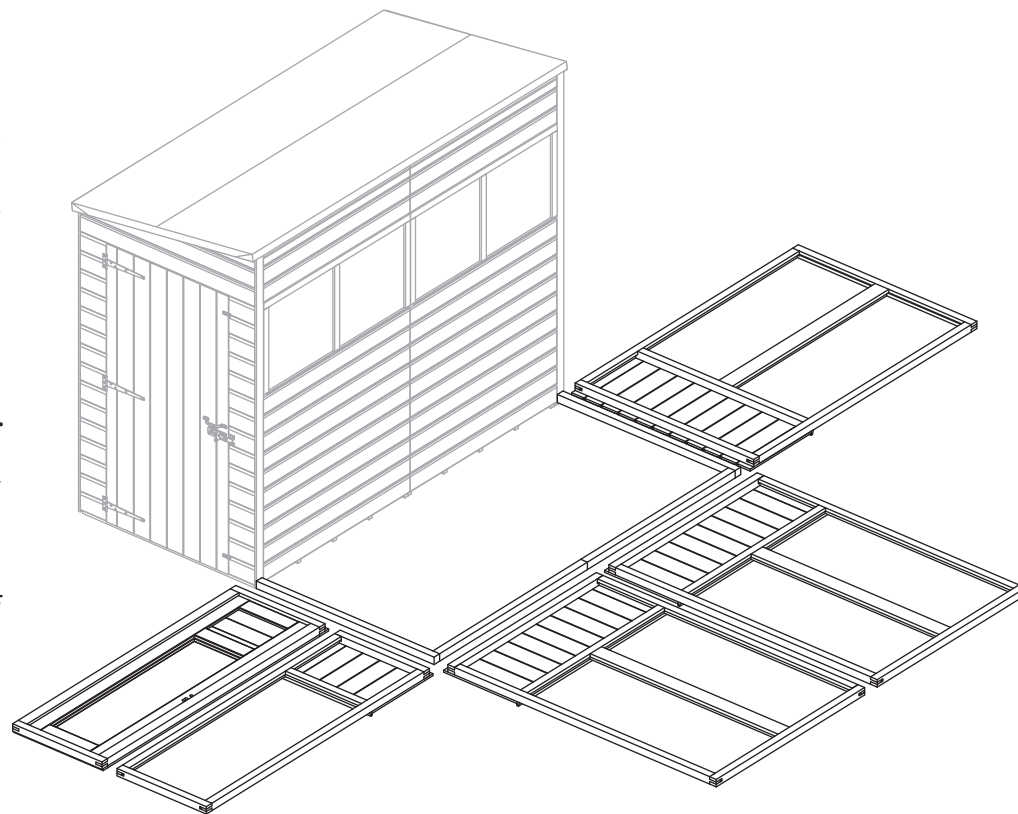

Step 29

Parts Needed

Building	No. 9	60mm screw
8x8	QTY 2	QTY 6

****Please note: the 2ft panels (No. 8a & 8b) are interchangeable and can be positioned in a variety of different configurations. Decide which works best for you before assembly.**

Locate a 4ft Glazing Panel (**No. 9**) on top of the Base Frame at one end. On the inside of the end panel, create the corner by positioning another 4ft Glazing Panel (**No. 9**).

Ensure to position the Panels so the 4ft Panel on the end is flush to the Shed Panel cladding / corner Cover Trim, as shown. Make sure to position the Panels so there is equal spacing between the overhanging cladding and the base frame on all sides.

Secure the Panels together at the corner and to the Shed Panel using 3x60mm screws per corner, as shown.

Do NOT secure the building to the base frame until the roof has been fitted.

Please note: the 'Doors on the end' has been shown for illustrative purposes and may differ from your chosen configuration. However, the process of fitting the panels is the same for all.

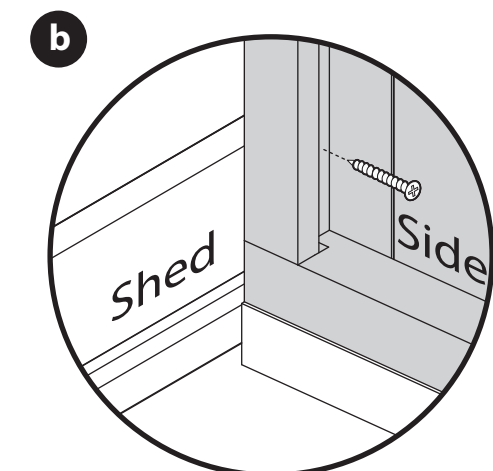
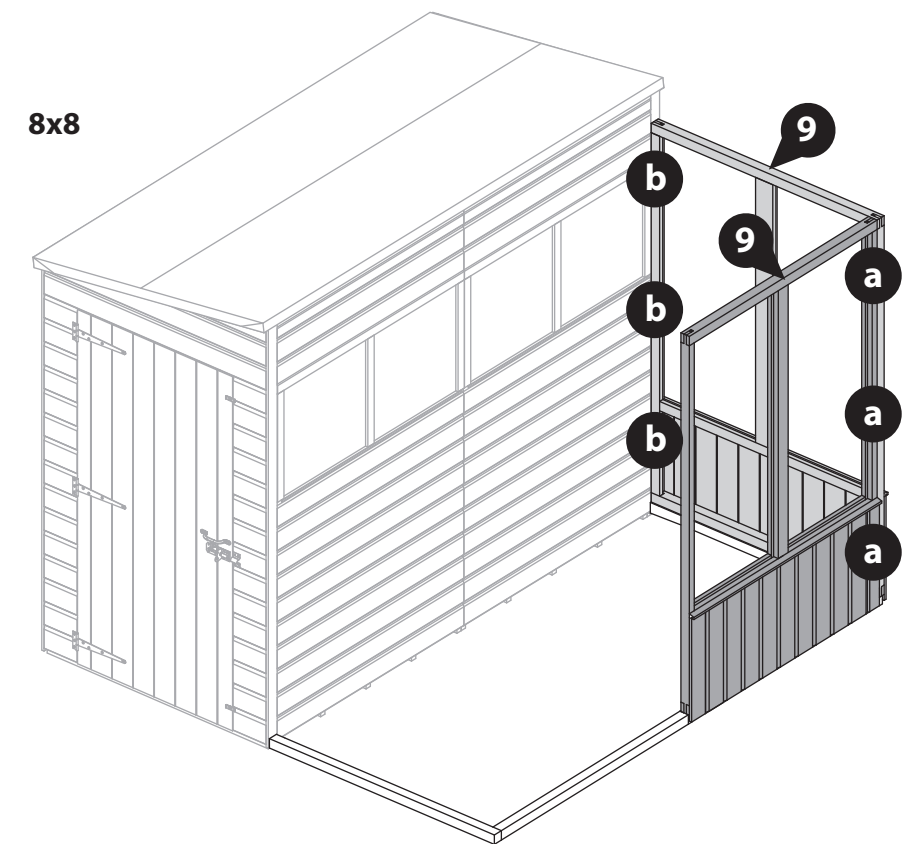
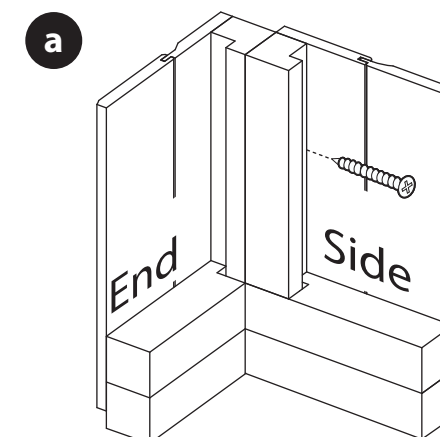

Step 30			Parts Needed	
Building	No. 9	60mm screw		
8x8	QTY 1	QTY 3		

IMPORTANT: Pre-drill before fixing screws.

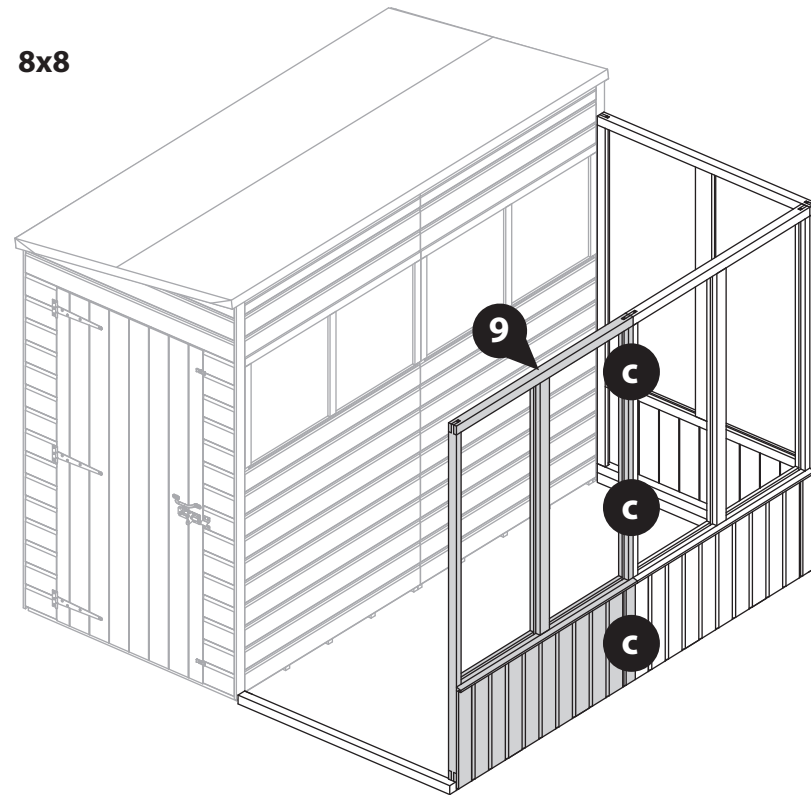

Locate another 4ft Glazing Panel (**No. 9**) next to the previously placed Panel on the side, as shown.

Secure the Panels together using 3x60mm screws, as shown.

Make sure to position the Panels so there is equal spacing between the overhanging cladding and the base frame on all sides.

Do NOT secure the building to the base frame until the roof has been fitted.

Please note: the 'Doors on the end' has been shown for illustrative purposes and may differ from your chosen configuration. However, the process of fitting the panels is the same for all.



c

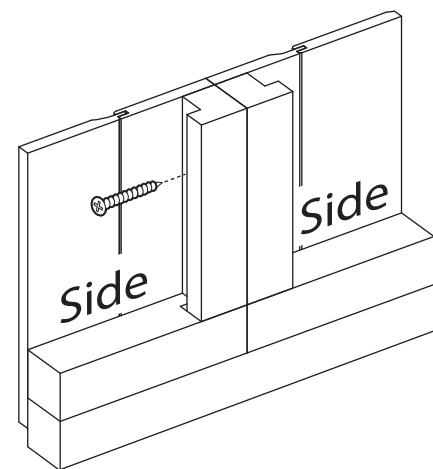

Step 31			Parts Needed	
Building	No. 8 (a or b)	60mm screw		
All sizes	QTY 2	QTY 9		

IMPORTANT: Pre-drill before fixing screws.

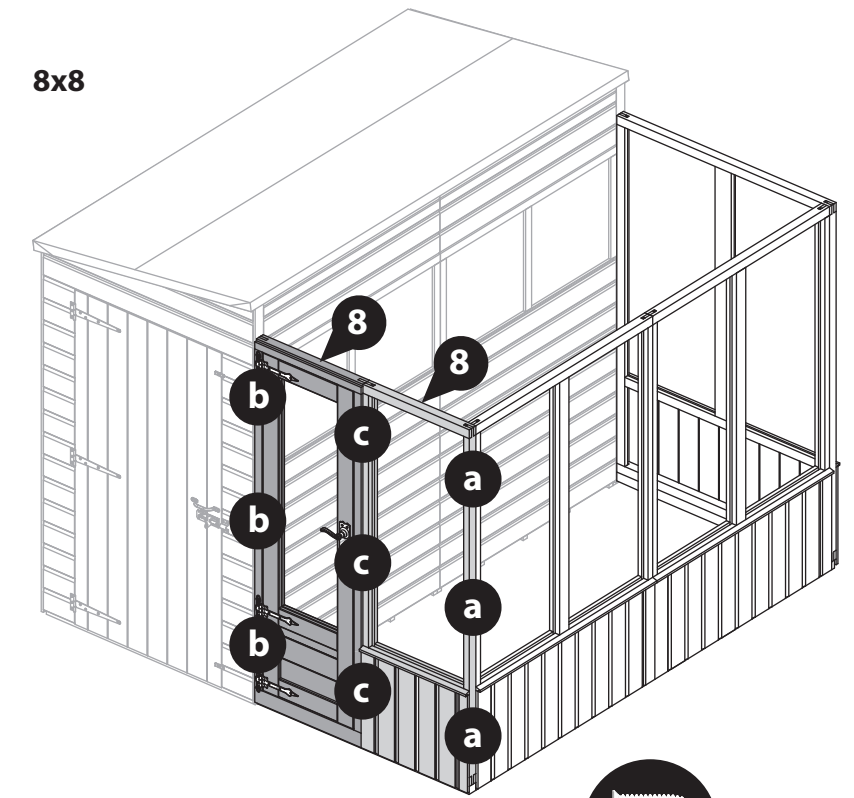

Locate the remaining 2ft Panels (**No. 8a & 8b**) on top of the Base Frame at the end, ensuring they sit on the outside of the previously placed panel, as shown.

Fix the Panels together using 3x60mm screws as shown.

Ensure to position the Panels so the 2ft Panel on the end is flush to the shed panel cladding / corner cover trim, as shown. Make sure to position the Panels so there is equal spacing between the overhanging cladding and the base frame on all sides.

Secure the Panels together at the corner and to the shed Panel using 3x60mm screws per corner, as shown.

Do NOT secure the building to the base frame until the roof has been fitted.

Please note: the 'Doors on the end' has been shown for illustrative purposes and may differ from your chosen configuration. However, the process of fitting the panels is the same for all.



a

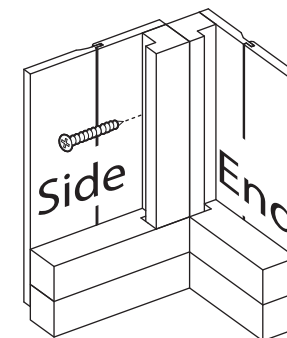

b

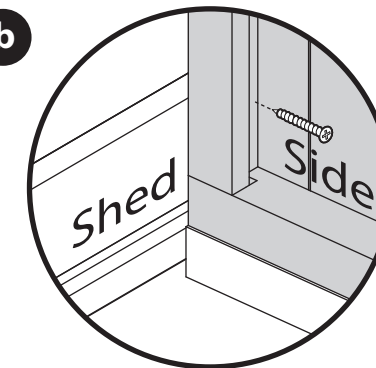

c

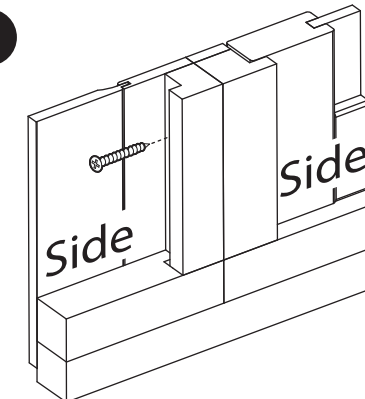

Step 32

Parts Needed

Building	No. 6	No. 7	60mm screw
All sizes	QTY 1	QTY 1	QTY 8

Locate the remaining Gable Tops (**No. 6 & 7**) on top of the end Panels, ensuring that the framing is flush and level.

Make sure that the tallest part of the Gable Top is positioned towards the shed side of the building, as shown.

Secure in place using 4x60mm screws per Gable, screwing down through the Gable framing into the Panel below.

Please note: the 8x8 'Doors on the end' has been shown for illustrative purposes and may differ from your chosen configuration. However, the process of fitting the Gable Tops is the same for all.

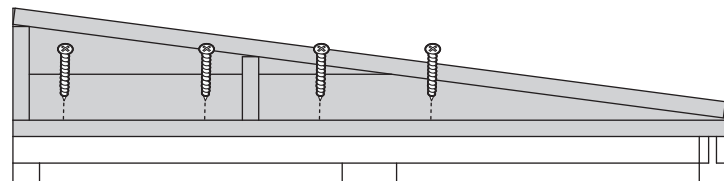

Internal view

IMPORTANT: Pre-drill before fixing screws.

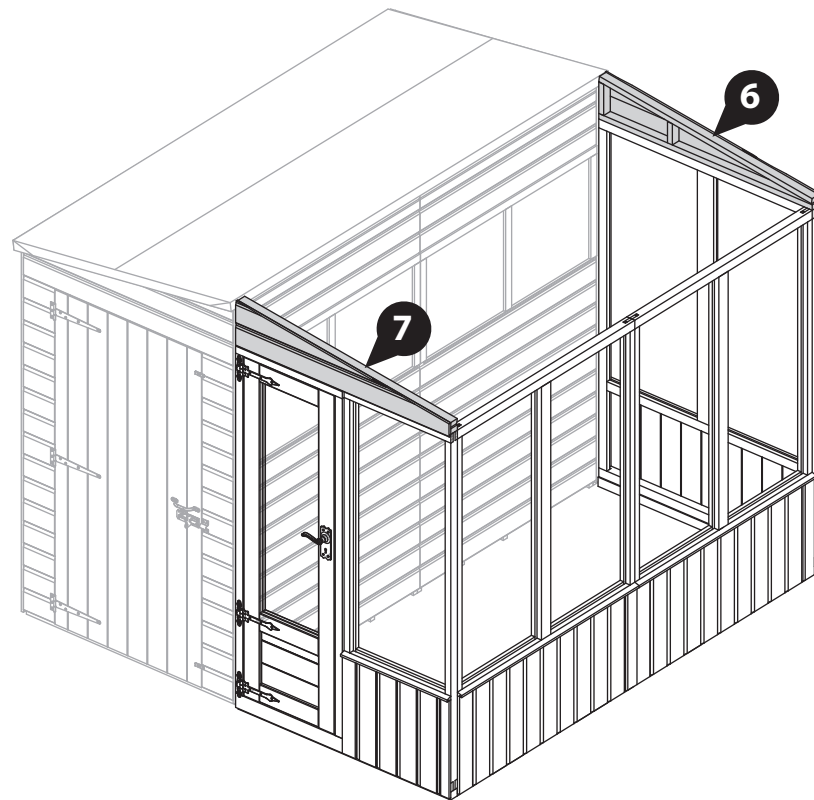

Step 33

Parts Needed

Building	No. 15	No. 32	No. 33	30mm screw
8x8	QTY 2	QTY 1	QTY 2	QTY 14

Position the Ridge Bars (**No. 15**) in a row so the ends are flush together and the faces are level. Position one U-channel (**No. 32**) centrally across the join and secure in place using 10x30mm screws.

Locate one Corner Brace (**No. 33**) onto either end of the Ridge Bar, ensuring they are flush with the ends of the framing, as shown.

Secure in place using 2x30mm screws per Corner Brace (**No. 33**).

This has constructed your Ridge bar.

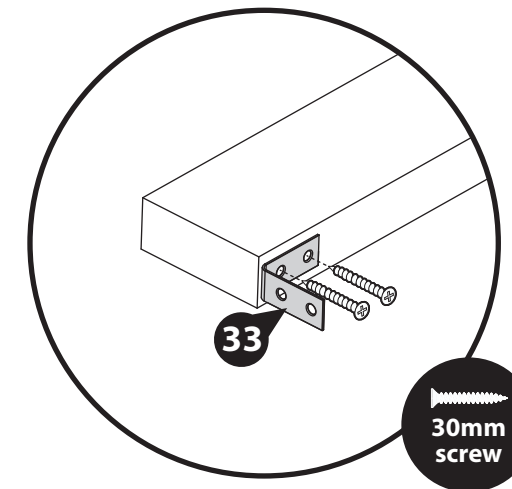
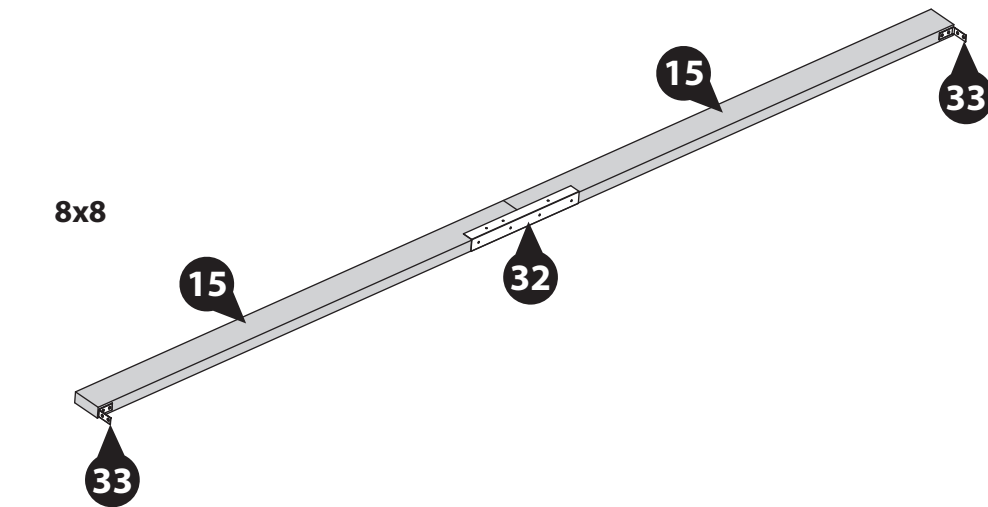
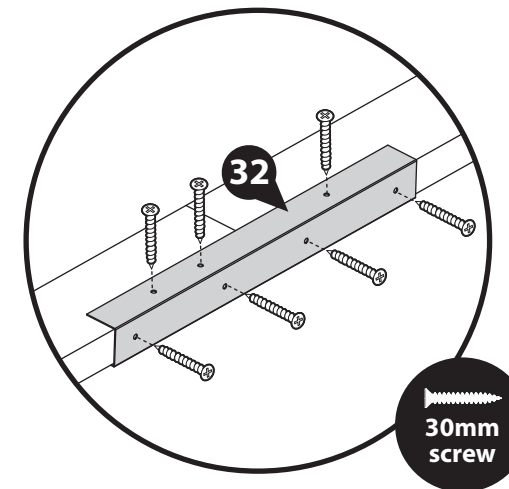

IMPORTANT: Pre-drill before fixing screws.

Step 34 Parts Needed

Building 30mm screw

All sizes QTY 4

IMPORTANT: Pre-drill before fixing screws.

Align the assembled Ridge Bar (**No. 15**) with the outer-most framing of the Gable Tops, ensuring the sides are flush.

Position the Ridge Bar 62mm below the top point of the Gable Tops, as shown.

(If you have not yet assembled your Ridge Bar, please refer to step 33).

Secure the Corner Braces (**No. 33**) to the upright of the Gable Tops using 2x30mm screws per brace.

Please note: the 8x8 'Doors on the end' has been shown for illustrative purposes and may differ from your chosen configuration. However, the process of fitting the Ridge Bar is the same for all.

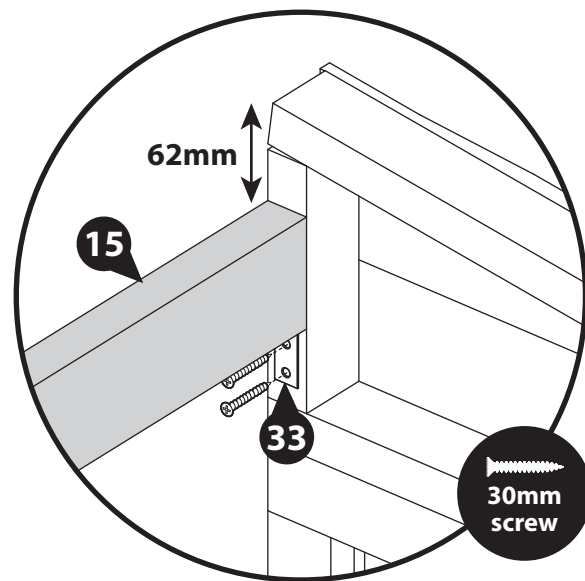
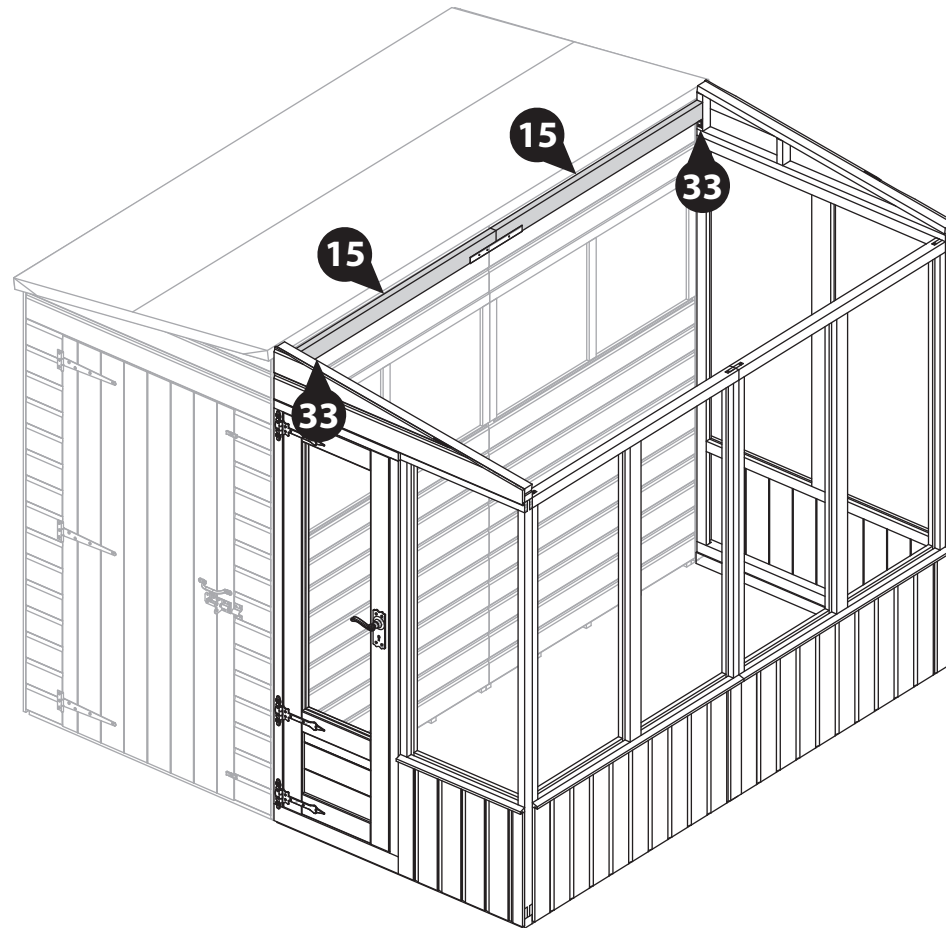

IMPORTANT: Pre-drill before fixing screws.

Step 35

Parts Needed

Building	No. 12	No. 13	No. 22	No. 24	No. 37	No. 38	16mm black screw	30mm black screw	30mm screw	50mm screw
8x8	QTY 1	QTY 1	QTY 1	QTY 1	QTY 2	QTY 1	QTY 4	QTY 16	QTY 2	QTY 2

- a** Place the 4ft Opening Window Roof (**No. 12**) face up on a flat and level surface.

Position the Window (**No. 13**) and the Window Block (**No. 22**) onto the Roof Panel (**No. 12**) framing, over the open space at the top right of the panel, as shown. The two should be flush and level with the side of the Roof Panel.

Ensuring the Window Block sits just below the top of the Panel and the Window sits on the central framing, secure the Window Block (**No. 22**) in place using 2x50mm screws.

- b** Place the Butt-Hinges (**No. 37**) onto the Window and Window Block. Fix in place using 8x30mm black screws per hinge.

- c** Whilst holding the window shut, flip the Panel over and position the Casement Stay (**No. 38**) centrally inside the Window, so the stay and pins align with the Roof and Window framing, as shown.

***Please ensure to support the window when flipping the panel as the window is not fully secured at this point and WILL open.*

Secure in place using 4x16mm black screws.

- d** With the Panel face down, measure the distance between the roof framing, as shown.

Mark this measurement onto one Cover Trim (**No. 24**) and cut to size.

Position the Cover Trim (**No. 24**) in between the top Roof framing, flush to the top framing. Ensure to cover the join between the Window and Window Block, as shown.

Secure in place using 2x30mm screws, screwing through the trim into the window block behind.

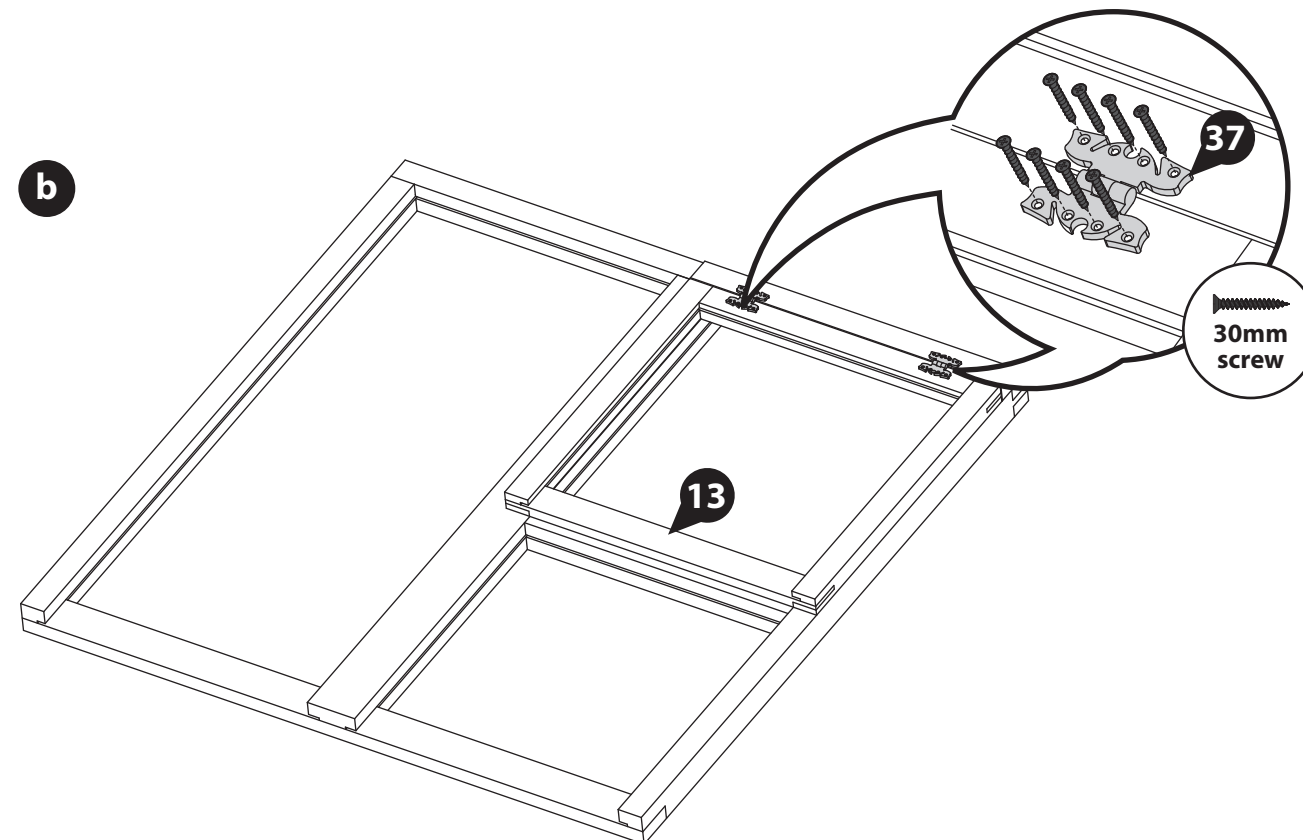
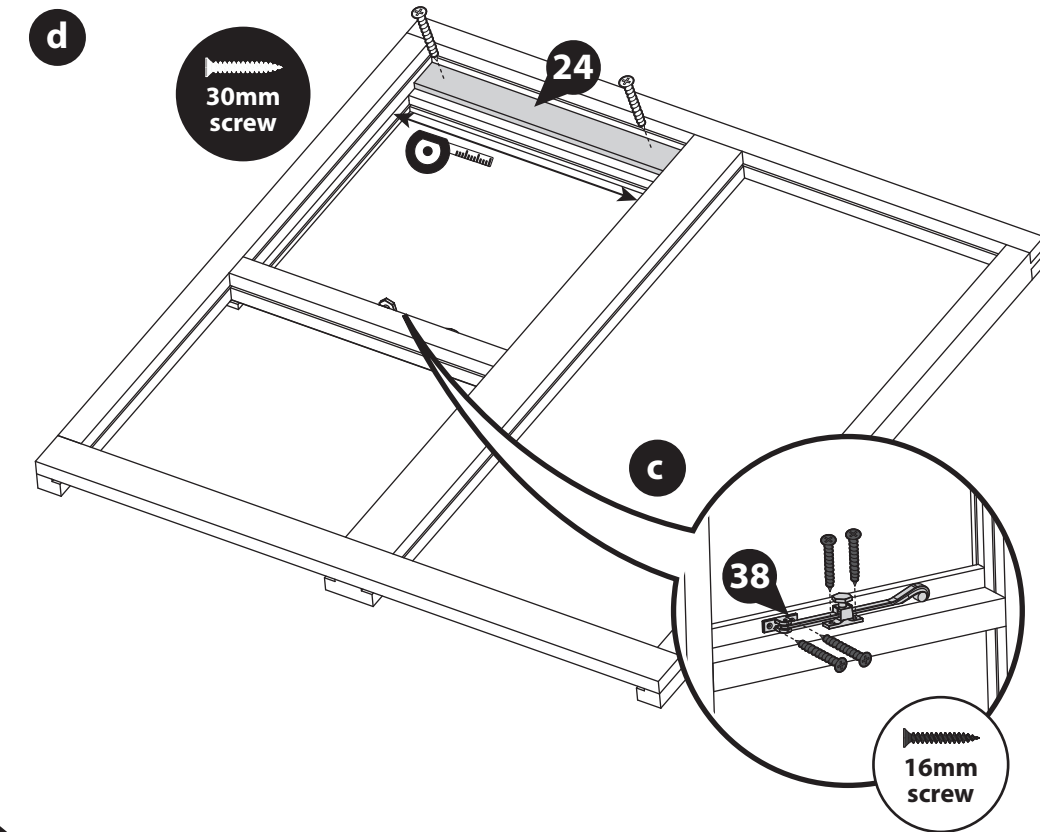
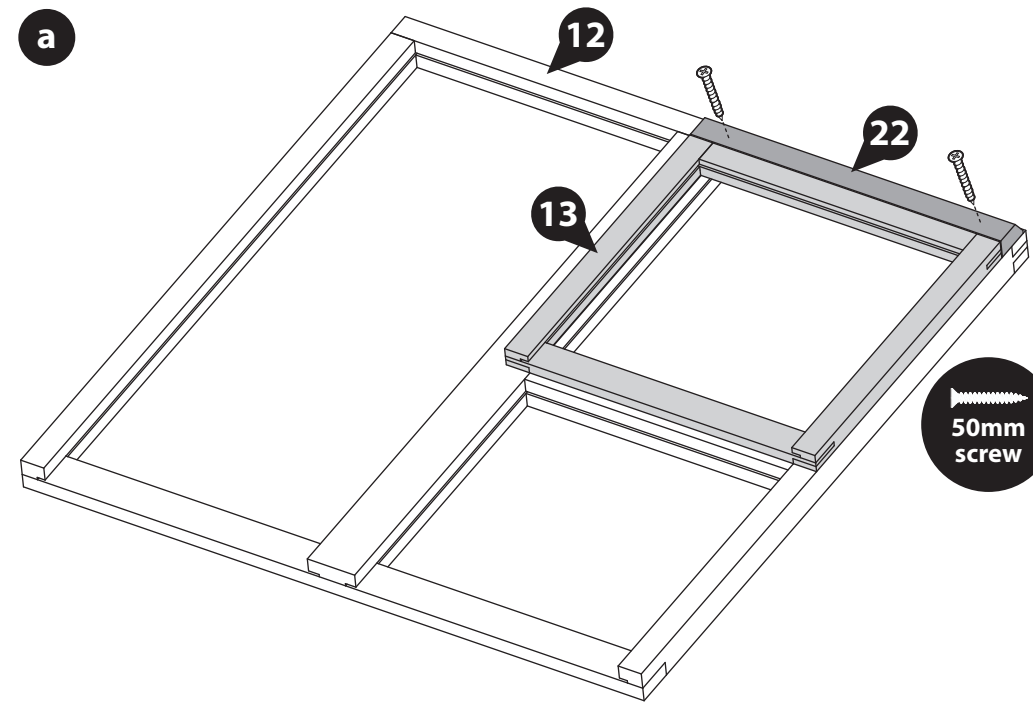

*Cut to fit

IMPORTANT: Pre-drill before fixing screws.

Step 36

Parts Needed

Building	No. 11	No. 12	70mm screw
8x8	QTY 1	QTY 1	QTY 10

**Please note: The 4ft Roof Panels (No. 11 & 12) are interchangeable and can be positioned in a variety of different configurations.*

Where possible, we recommend positioning your opening window panel as central to the greenhouse as possible, as this will allow for the best ventilation.

- a** At one end of the building, locate one Roof Panel (No. 11 or 12) on top of the building, ensuring the Panel sits inside the Gable Top, is flush to the top of the Gable top and sits firmly on the Ridge Bar.

Position the Roof so the framing at the top end of the Roof is flush with the side of the Ridge Bar and the cladding on the Shed Toppers, as shown.

Ensure to trap the Felt between the Shed Roof and Greenhouse Roof.

**Make sure to position your panels the correct way around. The stepped framing should be at the bottom, as shown.*

- b** Fix the Roof Panel to the Gable Top using 3x70mm screws per Roof, screwing through the bottom half of the Roof framing, into the Gable framing behind. Ensure to NOT screw into the Roof channel.

- c** Continue to Position the Roof panels (No. 11 or 12) onto the building, ensuring they are flush and level. Secure them together as you go using 4x70mm screws per join in an alternating pattern.

Once all the Roof Panels are positioned, secure the end Roof Panel to the Gable Top using 3x70mm screws.

Please note: The Greenhouse Roof will sit slightly lower than the Shed Roof.

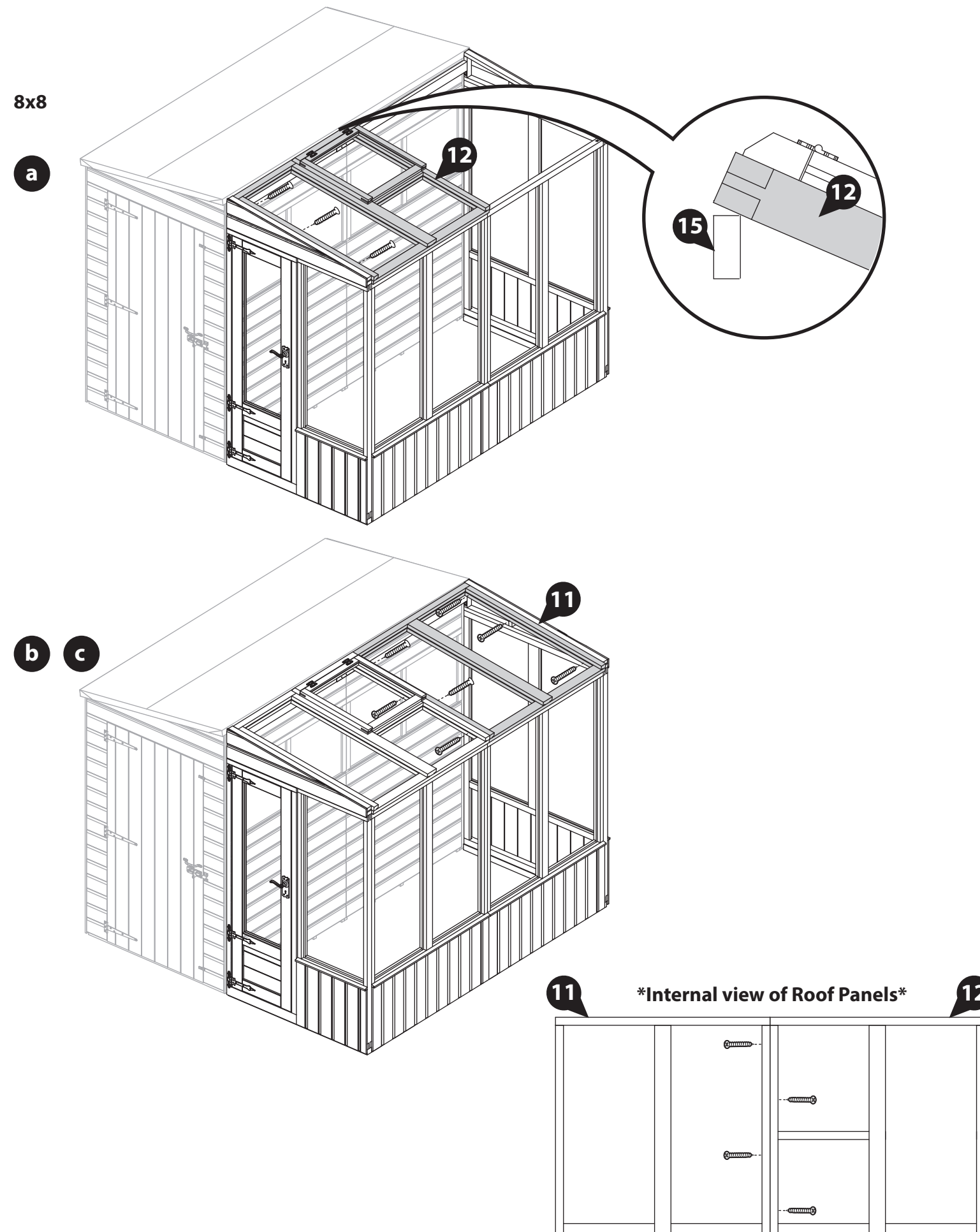

Step 37

Parts Needed

Building	No. 19	50mm screw
8x8	QTY 1	QTY 5

Position one Greenhouse Truss Frame (No. 19) underneath the joining Roof Panels (No. 11 & 12) so it is central to where they join, as shown.

Ensure to align the angled ends of the Greenhouse Truss Frame (No. 19) so they sit flush to the Wall Panel framing and flush to the Ridge Bar, as shown.

Fix the Greenhouse Truss Frame (No. 19) in place using 5x30mm screws per frame, screwing up through the Truss Frame (No. 19) into the Roof Panels (No. 11 & 12) in an alternating pattern.

It is essential that the Greenhouse Truss Frame (No. 19) and Roof Panels (No. 11 & 12) pull together when secured.

Please note: the 8x8 'Doors on the end' has been shown for illustrative purposes and may differ from your chosen configuration. However, the process of fitting the Greenhouse Truss Frame is the same for all.

IMPORTANT: Pre-drill before fixing screws.

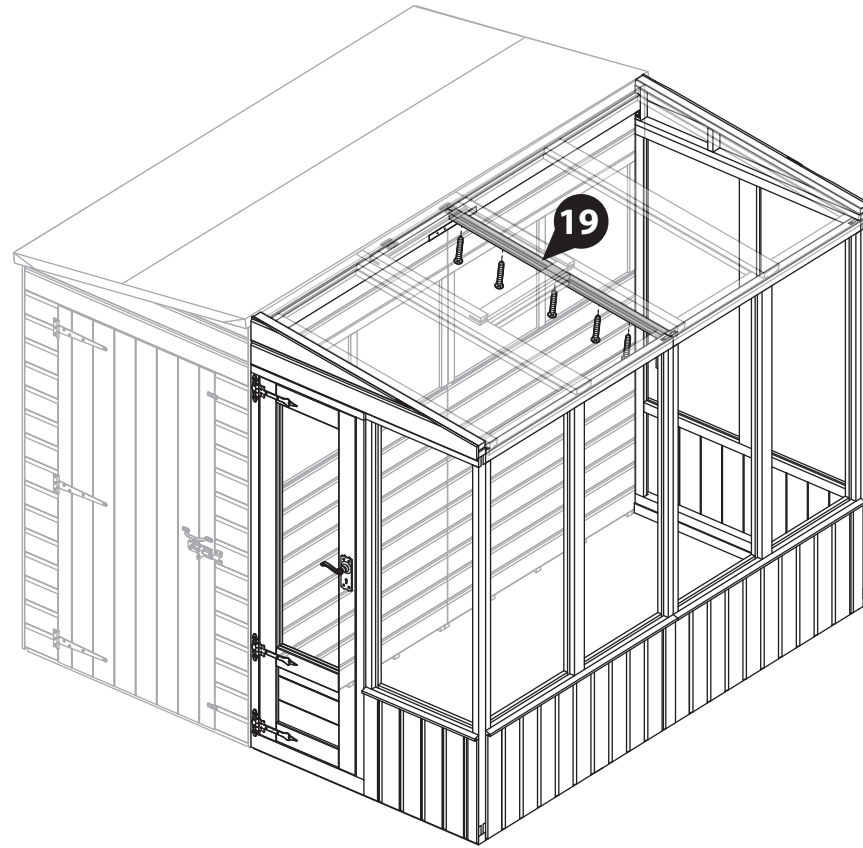

Step 38

Parts Needed

Building	No. 18	50mm screw
8x8	QTY 1	QTY 2

Please note: You have been provided with two Truss Blocks (No. 18) however you only need to use one.

On the Greenhouse side of the building, place the Truss Block (No. 18) up to the Greenhouse Truss Frame (No. 19) so the angled cut edge is facing upwards, flush to the Greenhouse Truss Frame (No. 19).

Ensure the Truss Block is also flush to the Panel uprights behind.

Fix in place using 2x50mm screws through the truss Block into the framing behind, alternating which Panel upright you screw in to, as shown.

Please note: the 8x8 'Doors on the end' has been shown for illustrative purposes and may differ from your chosen configuration. However, the process of fitting the Truss Block is the same for all.

IMPORTANT: Pre-drill before fixing screws.

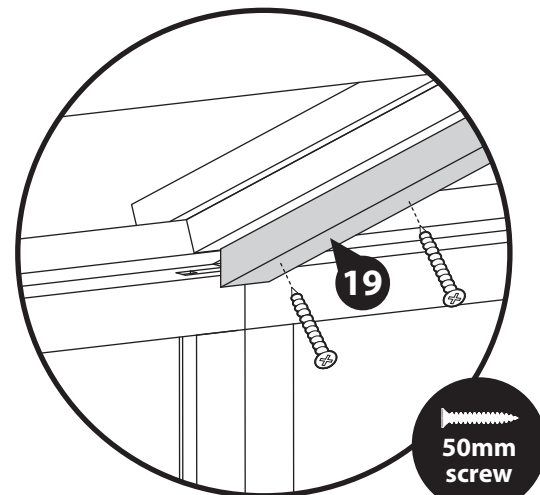
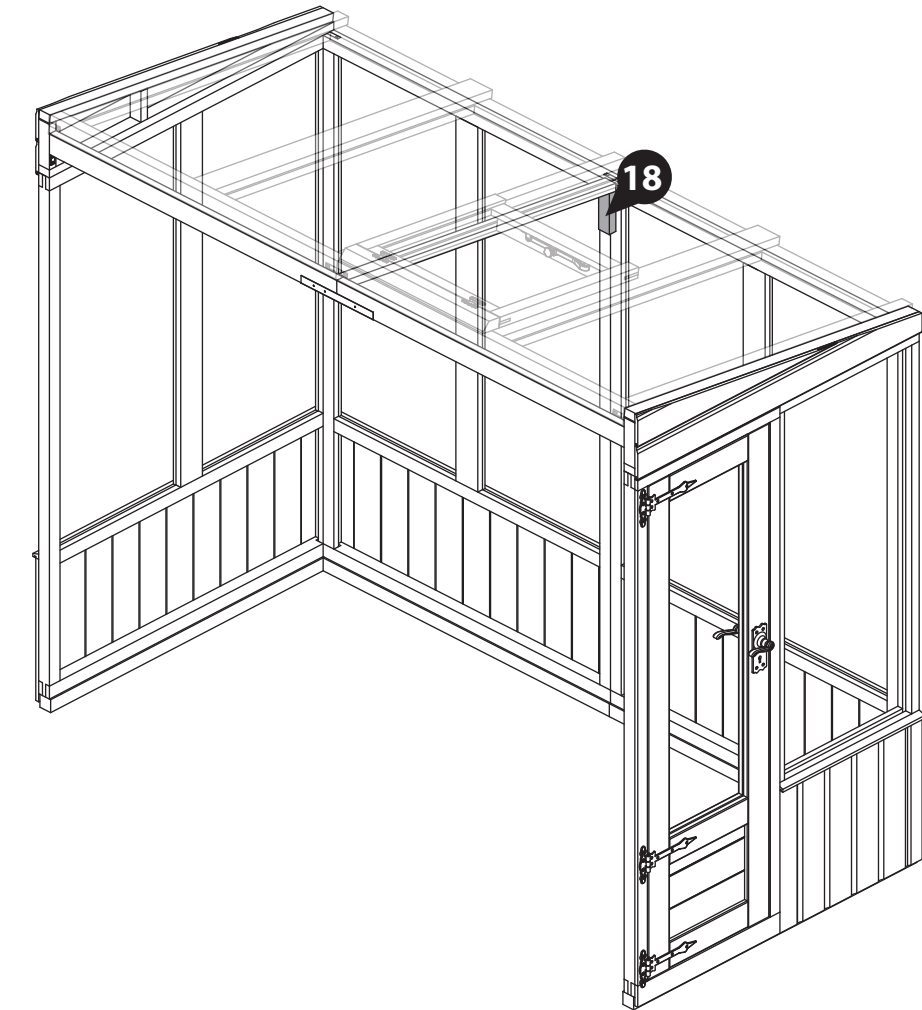

Internal View

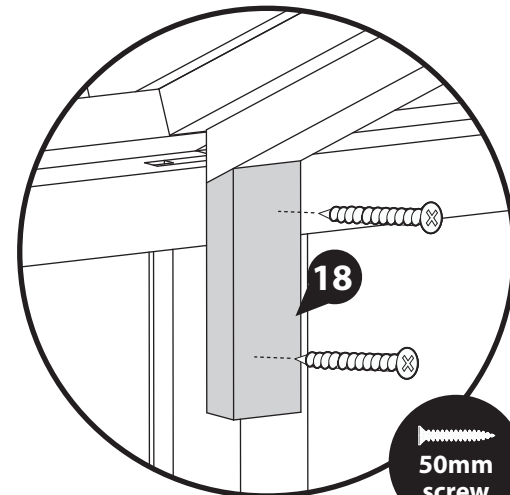

Internal View

Step 39

Parts Needed

Building	No. 33	30mm screw
8x8	QTY 2	QTY 8

Secure the Greenhouse Truss Frame (No. 19) to the Ridge Bars (No. 15), by placing one Corner Brace (No. 33) either side of the Truss Frame. Ensure they are flush to both the Truss Frame and Ridge Bars, as shown.

Fix in place using 4x30mm screws per Corner Brace.

Please note: the 8x8 'Doors on the end' has been shown for illustrative purposes and may differ from your chosen configuration. However, the process of securing the Greenhouse Truss Frame is the same for all.

IMPORTANT: Pre-drill before fixing screws.

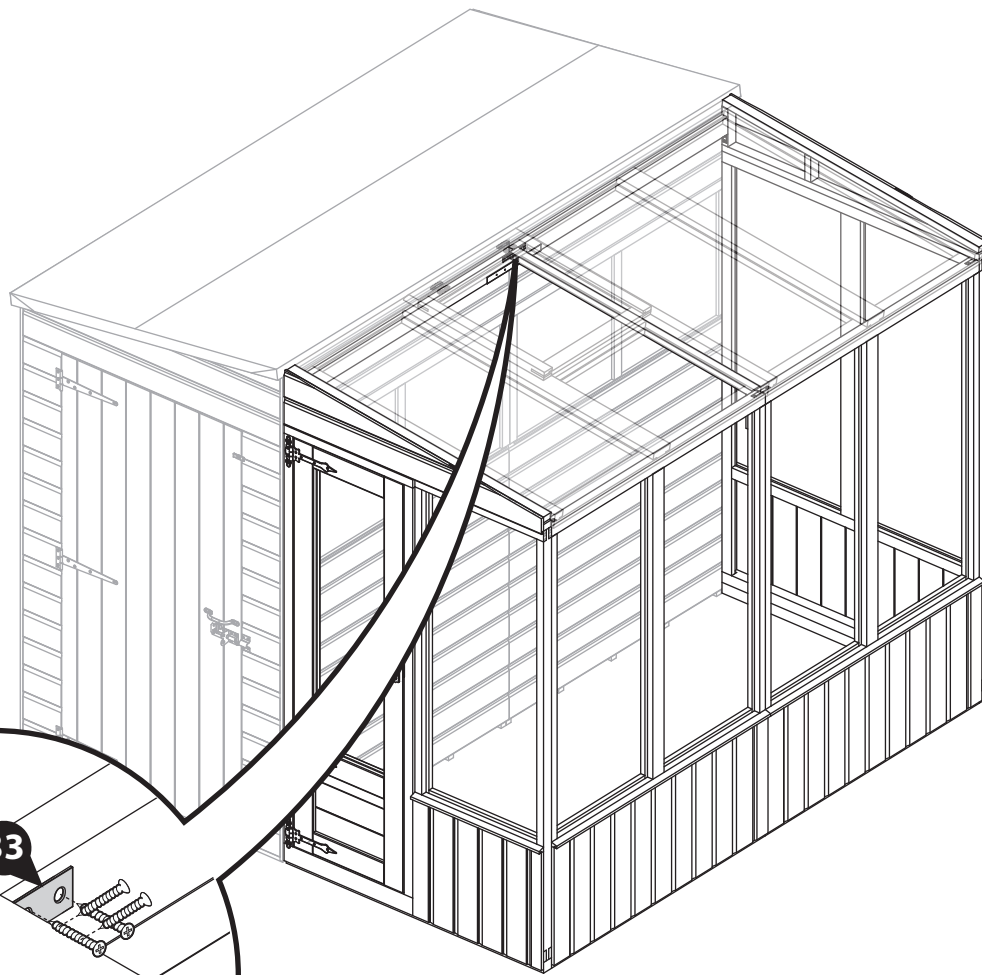

Step 40

Parts Needed

Building	50mm screw
8x8	QTY 8

Make sure the building is square by measuring from corner to corner and comparing the measurements. If the measurements are equal, the building is square, if not, adjustments may be required.

Once square, secure the Roofs in place using 50mm screws, screwing down through the Roof framing into the Panel framing below.

Ensure the screws are countersunk to avoid interference when glazing.

Please note: the 8x8 'Doors on the end' has been shown for illustrative purposes and may differ from your chosen configuration. However, the process of fixing the Roof is the same for all.

IMPORTANT: Pre-drill before fixing screws.

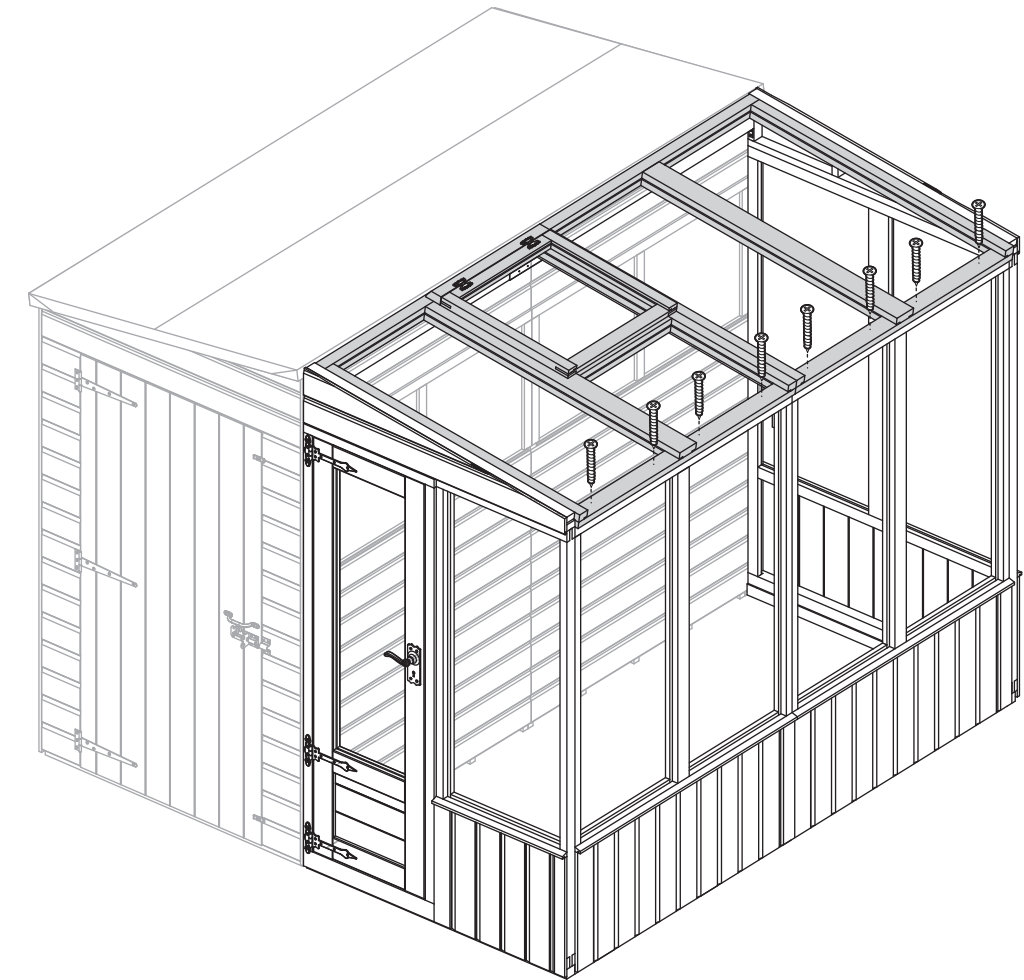

Step 41

Parts Needed

Building

70mm screw

8x8

QTY 13

Once the Roof is fixed, secure the Panels to the base frame using 70mm screws, screwing down through the Panel framing into the base frame below.

Please note: the 8x8 'Doors on the end' has been shown for illustrative purposes and may differ from your chosen configuration. However, the process of fixing the Panels is the same for all.



d

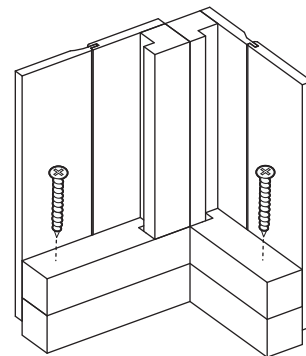

70mm screw

IMPORTANT: Pre-drill before fixing screws.

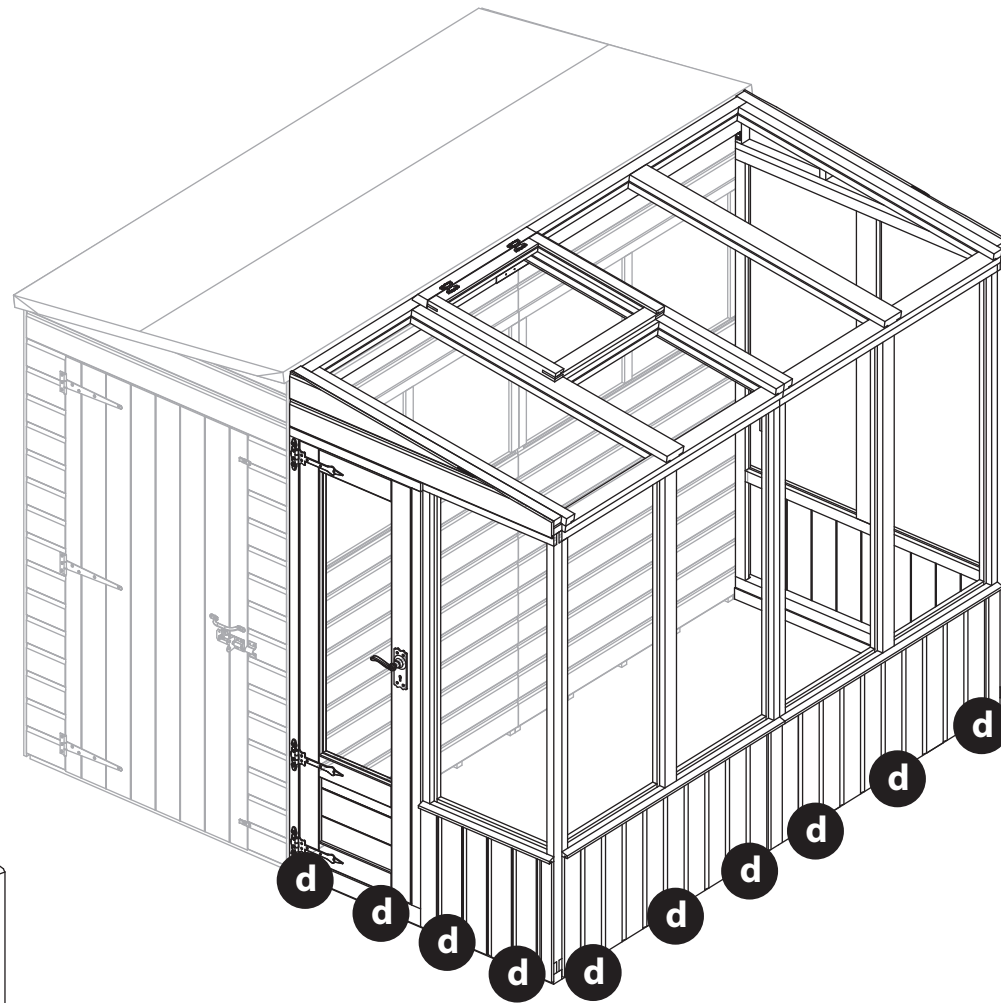

Step 42

Parts Needed

Building

No. 24

30mm screw

8x8

QTY 4

QTY 15

a

On the Greenhouse side and the top side of the Shed, at each corner and Panel join, use a tape measure to measure the distance the Cover Trims needs to fill e.g. from the bottom of the Panel to the top of the Panel or from the top of the cill to the top of the panel.

Mark the measurements onto the Cover Trims (No. 24) and cut to size if required.

Please note: For the Greenhouse panel joins, one Cover Trim can be cut to create both the top and bottom. Ensure to use all of one Cover Trim where possible before cutting a new one. Do not dispose of off-cuts until the building is fully constructed as they may be needed in another step.

b

Locate the Cover Trims (No. 24) over each Panel join and corner, ensuring they sit centrally over the joins and flush to the Panel cladding at the corners.

Secure in place using 3x30mm screws per Cover Trim, alternating fixing into each Panel when over a join.

Please note: the 8x8 'Doors on the end' has been shown for illustrative purposes and may differ from your chosen configuration. However, the process of fitting the Cover Trims is the same for all.



*Cut to fit

IMPORTANT: Pre-drill before fixing screws.

a

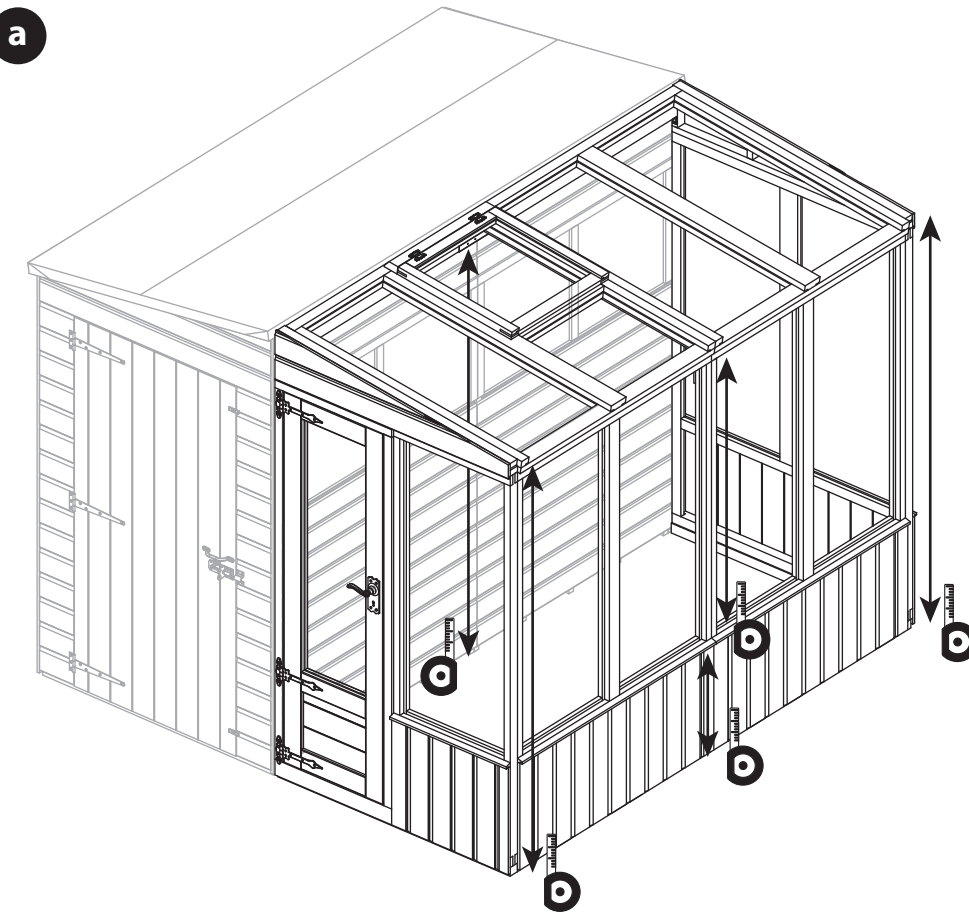

b

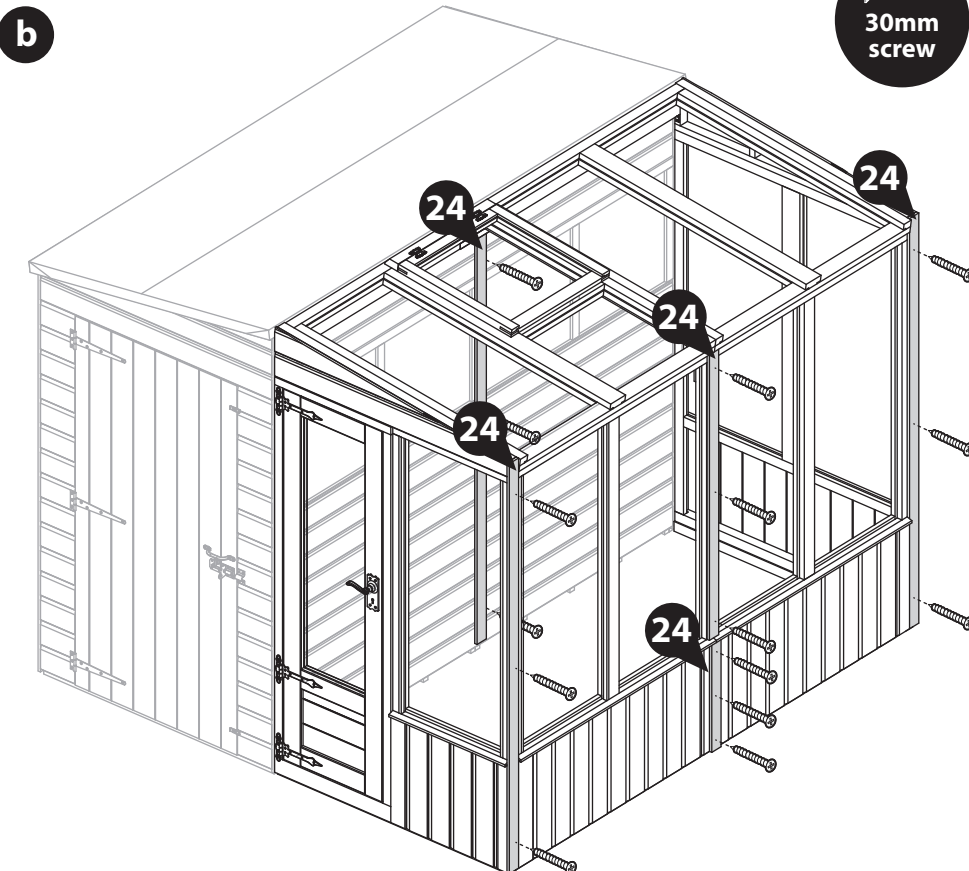

30mm screw

Step 43

Parts Needed

Building	No. 23	50mm screw
All sizes	QTY 2	QTY 6

IMPORTANT: Pre-drill before fixing screws.

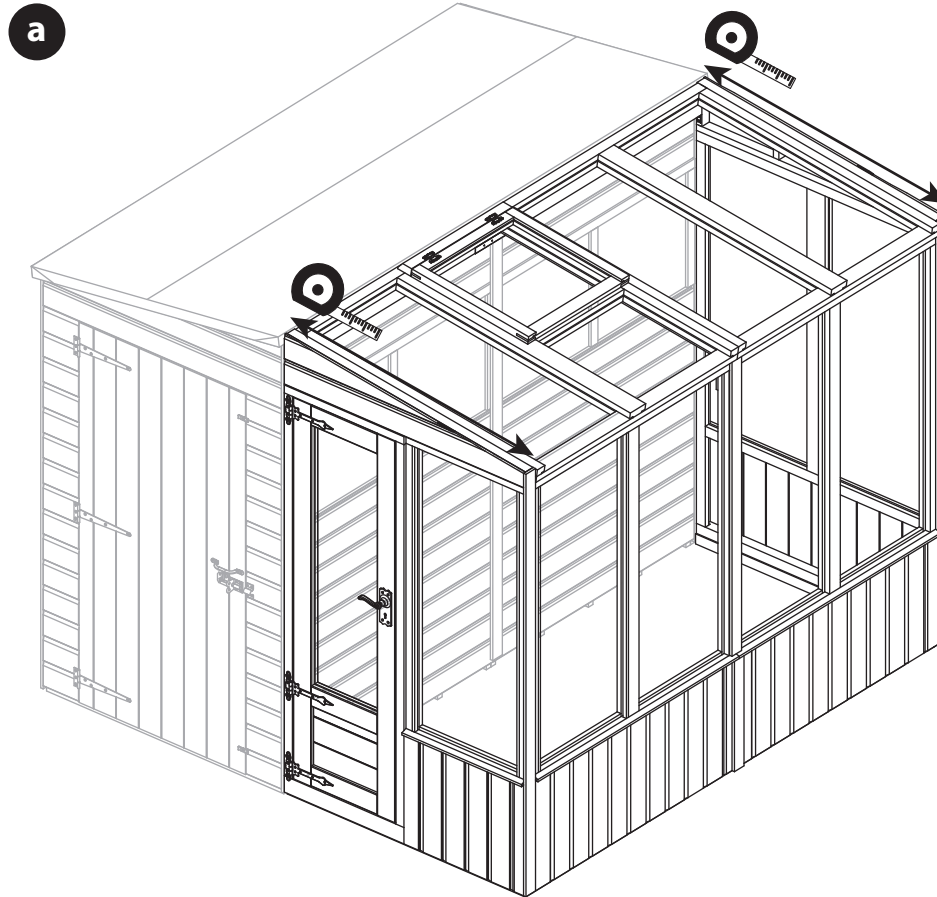

a At each end of the Greenhouse, use a tape measure to measure the total distance from where the two buildings meet to the bottom of the Gable Top, as shown.

Mark the measurements onto two Eaves Frames (**No. 23**) and cut to size.

b Locate the cut down Eaves Frames (**No. 23**) on to the front of the Gable Tops on either end of the building, ensuring that the framing is flush to the top of the Gable, as shown.

Secure in place using 3x50mm screws per Eaves Frame.

These Eaves frames should bring the Greenhouse ends level with the shed ends.

Please note: the 8x8 'Doors on the end' has been shown for illustrative purposes and may differ from your chosen configuration. However, the process of fitting the Eaves Framing is the same for all.

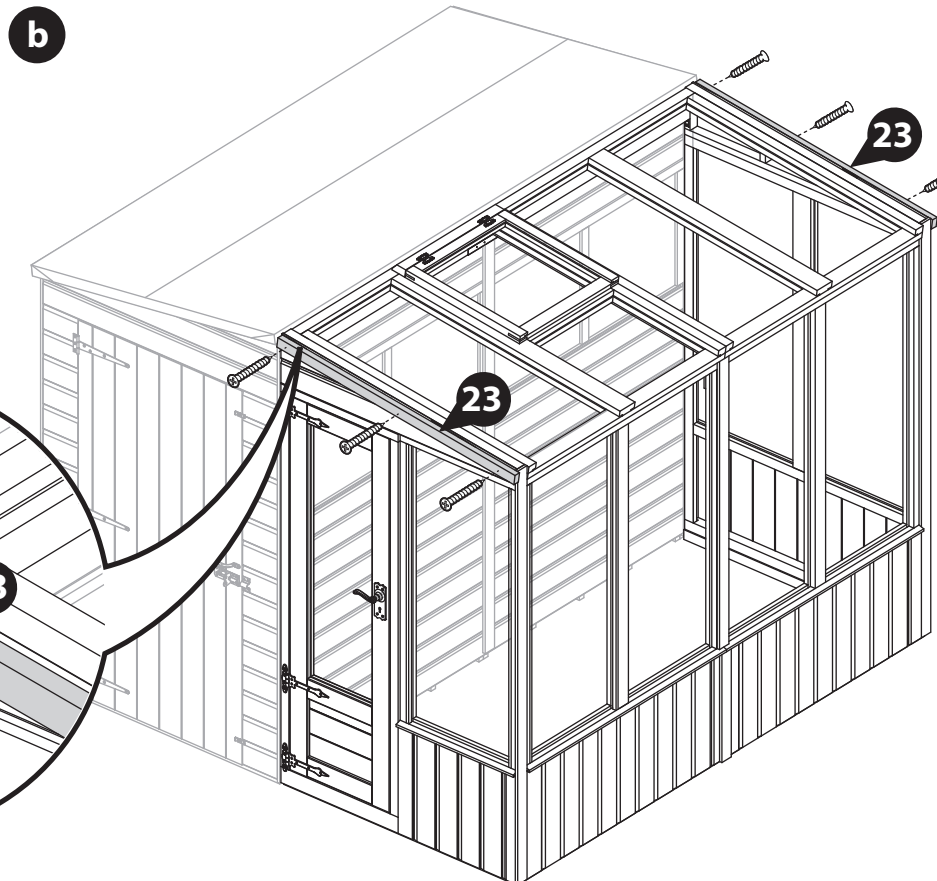

Step 44

Parts Needed

Building	No. 25	30mm screw
All sizes	QTY 2	QTY 8

IMPORTANT: Pre-drill before fixing screws.

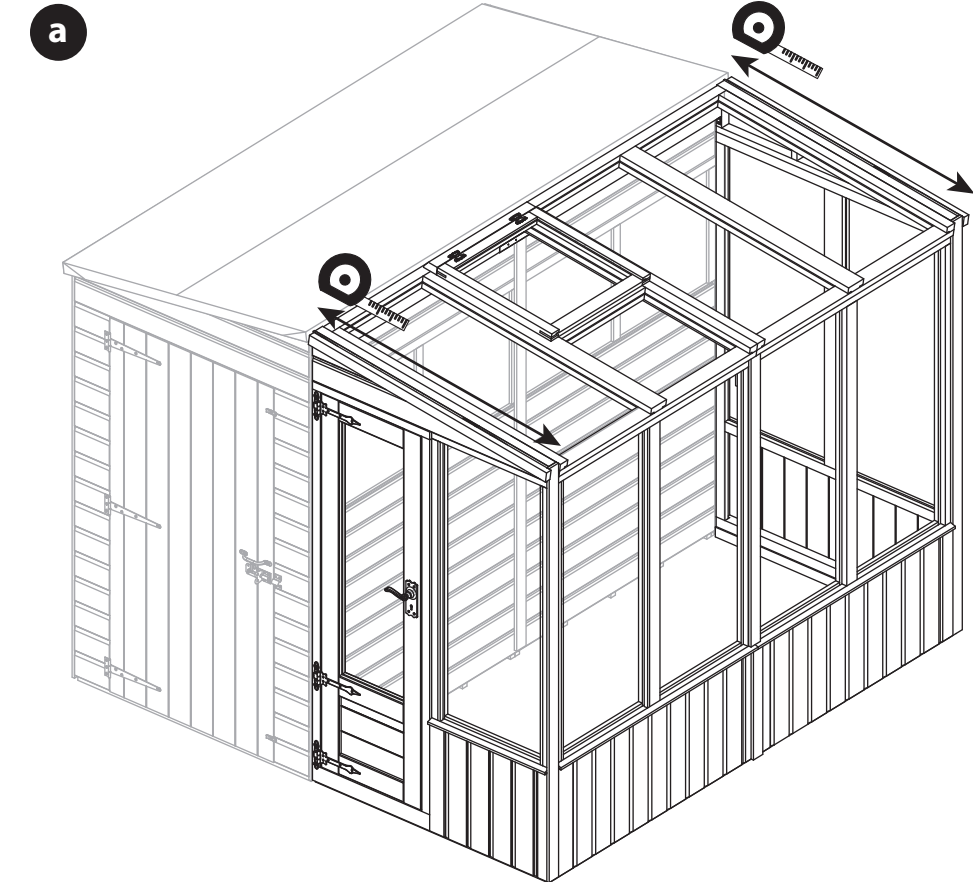

a At either end of the Greenhouse, use a tape measure to measure the distance from the top of the Roof Panel to the bottom, as shown.

Mark the measurements onto two Roof Trims (**No. 25**) and cut to size.

b Locate the Roof Trims (**No. 25**) over the joining Roof, Gable Top and Eaves framing at either end, ensuring they sit flush to the edge of the Eaves frame, as shown.

Secure in place using 4x30mm screws per Roof Trim, ensuring to stagger the screws to avoid them colliding with the ones below.

Please note: the 8x8 'Doors on the end' has been shown for illustrative purposes and may differ from your chosen configuration. However, the process of fitting the Roof Trims is the same for all.

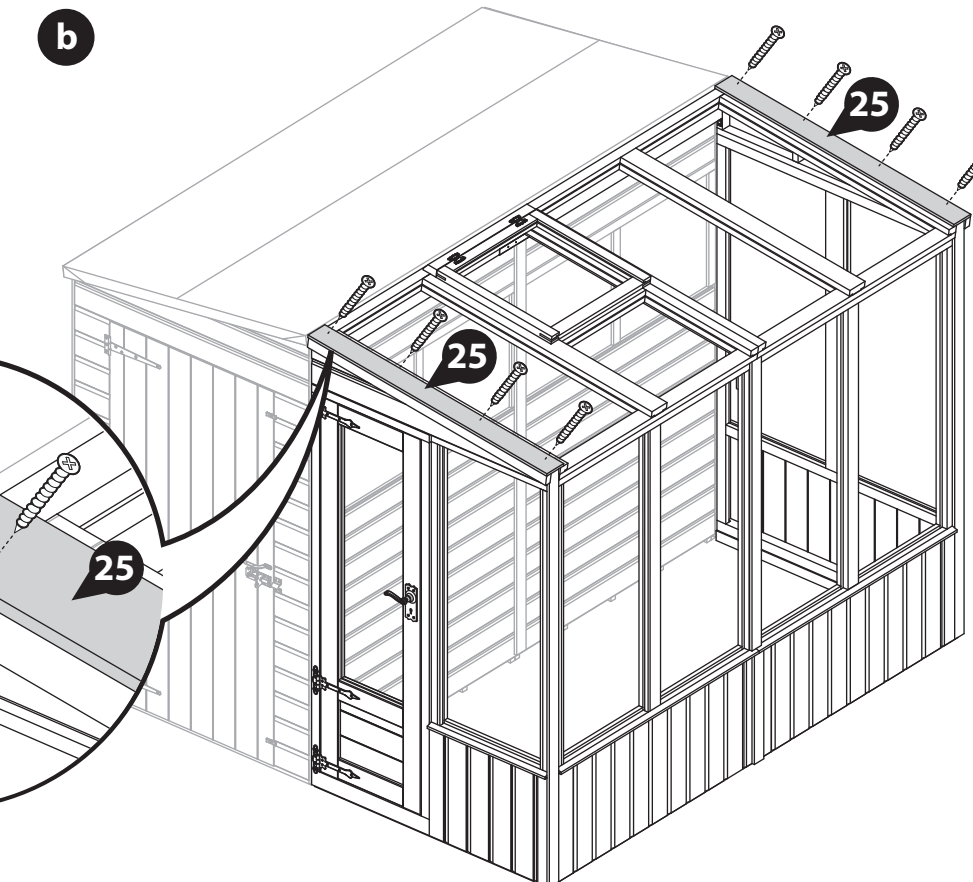

Step 45 Parts Needed

Building	No. 27	40mm screw
All sizes	QTY 4	QTY 12

Please note: You have been supplied with six Fascias (No. 27) however you may not need to use them all.

a At either end of the building, on both the Shed and Greenhouse sides, use a tape measure to measure the distance from the top of the Roofs to the bottom as shown.

Mark the measurements onto four Fascias (No. 27) and cut to size.

b Position the cut down Fascias onto the ends of the building, ensuring to trap the Felt between the Shed Roof and the Fascia.

Secure in place using 3x40mm screws per Fascia.

For a neat finish, you may wish to cut an angle into the Fascias where they meet at the top of the Roofs, as shown.

Please note: the 8x8 'Doors on the end' has been shown for illustrative purposes and may differ from your chosen configuration. However, the process of fitting the Fascias is the same for all.

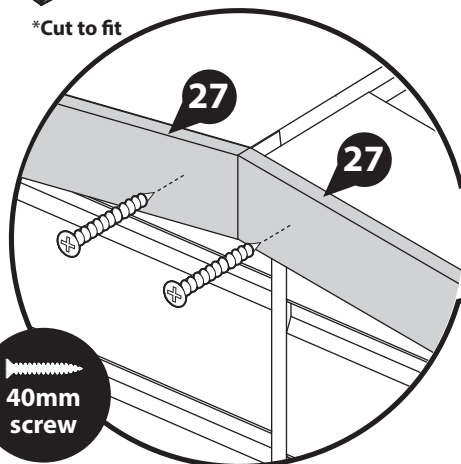

IMPORTANT: Pre-drill before fixing screws.

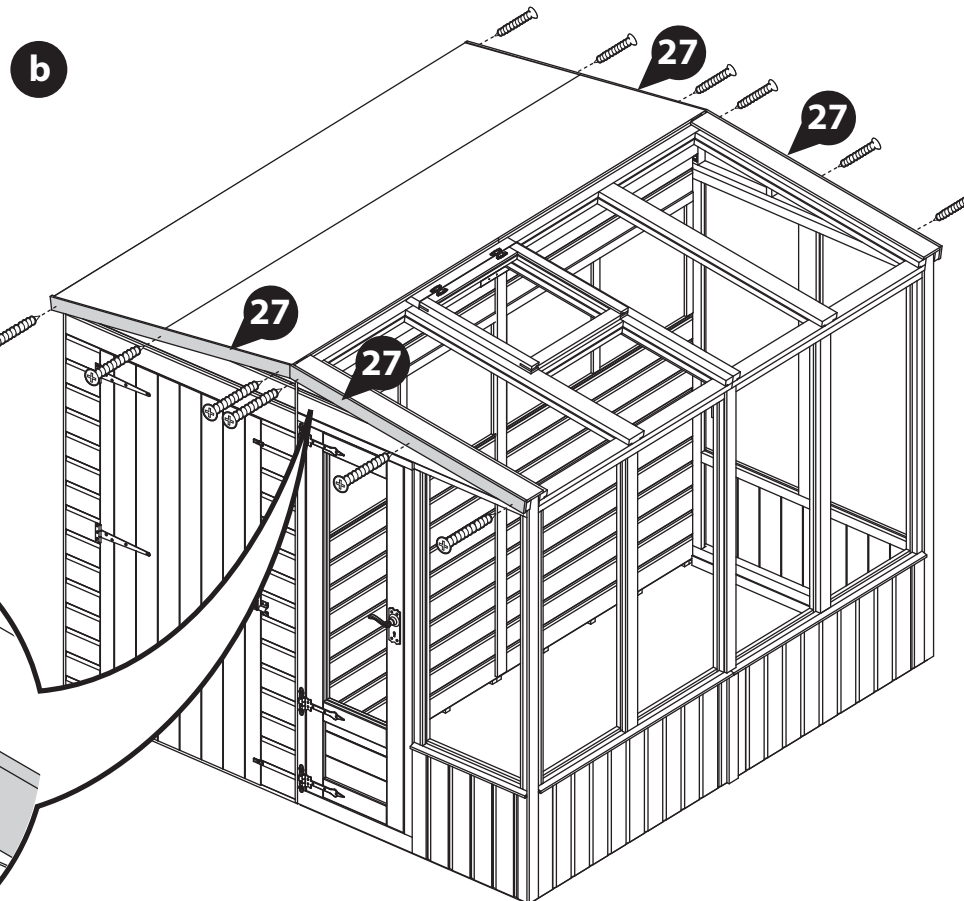
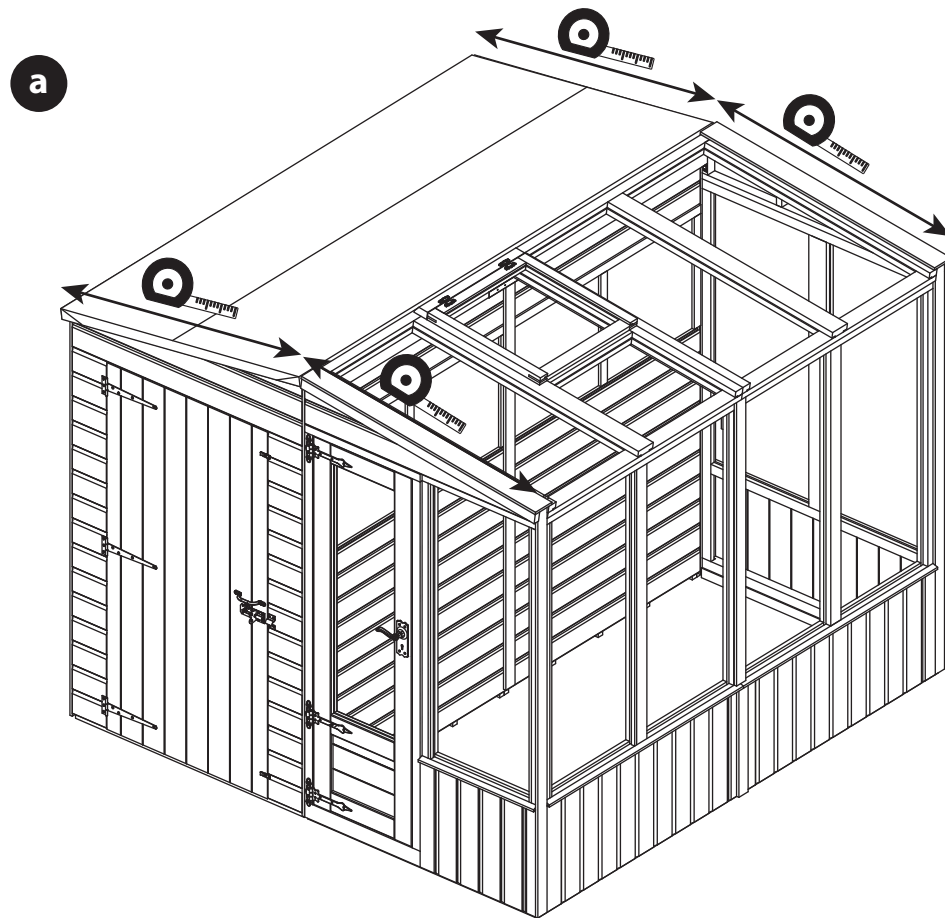

Step 46 Parts Needed

Building	No. 26	40mm screw
All sizes	QTY 2	QTY 6

a On the back side of the shed, use a tape measure to measure the distance between the previously fitted Fascias, as shown.

Half this measurement and mark the new total onto two Fascias (No. 26), and cut to size.

b Position the cut down Fascias (No. 26) on to the back of the building, ensuring to trap the Felt between the Roof and the Fascia.

Make sure to position the back Fascias (No. 26) level with the bottom of the Eaves Frame, ensuring it sits below the top of the Roof. This allows any water to drain off the back.

Secure in place using 3x40mm screws per Fascia.

Please note: the 8x8 'Doors on the end' has been shown for illustrative purposes and may differ from your chosen configuration. However, the process of fitting the Fascias is the same for all.

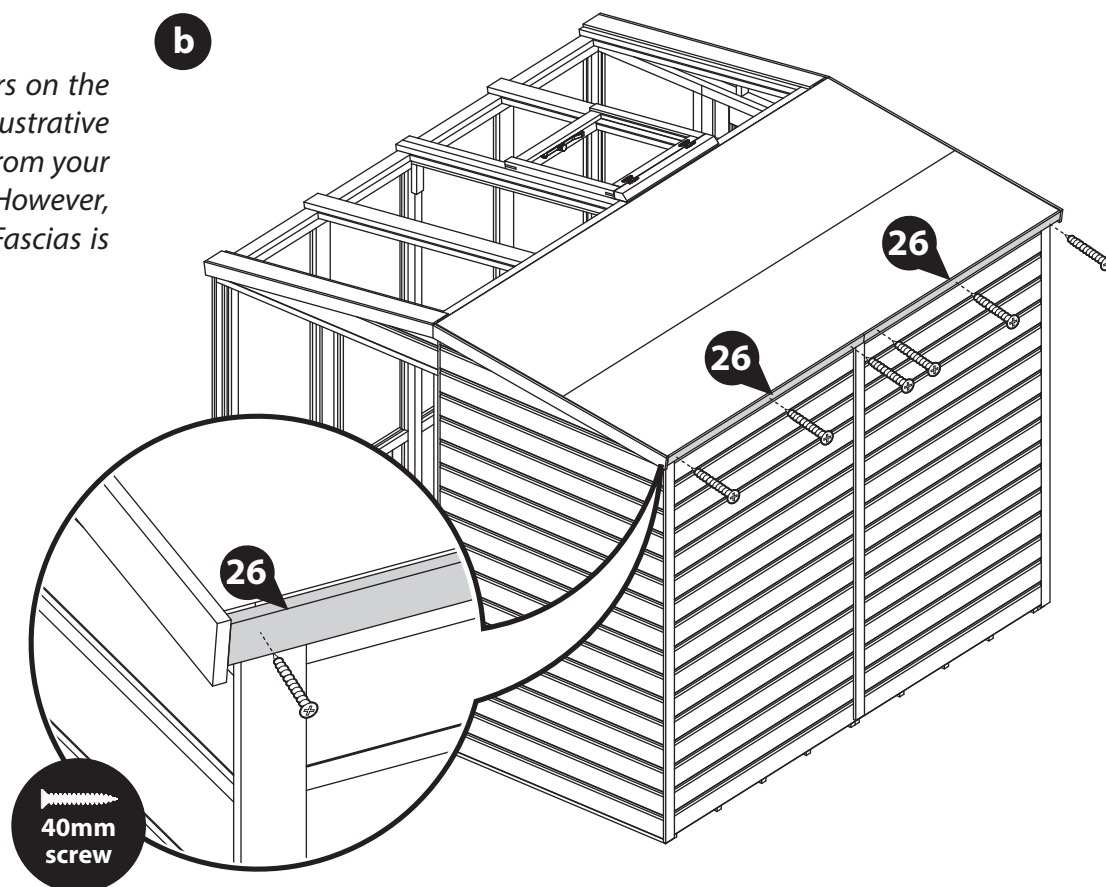

IMPORTANT: Pre-drill before fixing screws.

Step 47 Parts Needed

Building	No. 24	30mm screw
8x8	QTY 2	QTY 6

a At the top of the building, where the two sides meet, measure the total distance from end to end, as shown.

b Lay two Cover Trims (No. 24) out end-to-end so they are flush and level, and mark the total measurement onto the Cover Trims, as shown.

Use a saw to remove the excess material.

c Position the cut down Cover Trims (No. 24) centrally on top of the joining sides. Ensure the Cover Trims sit flush with the Fascias at either end.

Secure in place using 30mm screws, ensuring to fix through the Cover Trim into the roof framing below.

Please note: the 8x8 'Doors on the end' has been shown for illustrative purposes and may differ from your chosen configuration. However, the process of fitting the Cover Trims is the same for all.

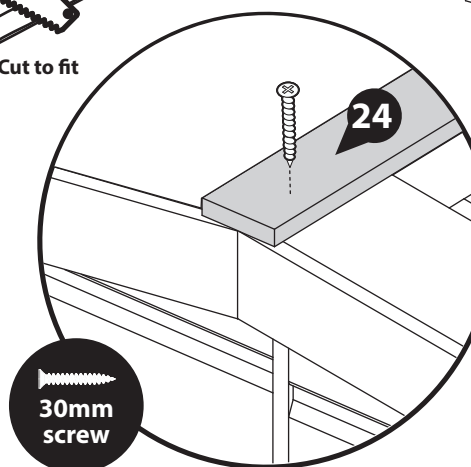

IMPORTANT: Pre-drill before fixing screws.

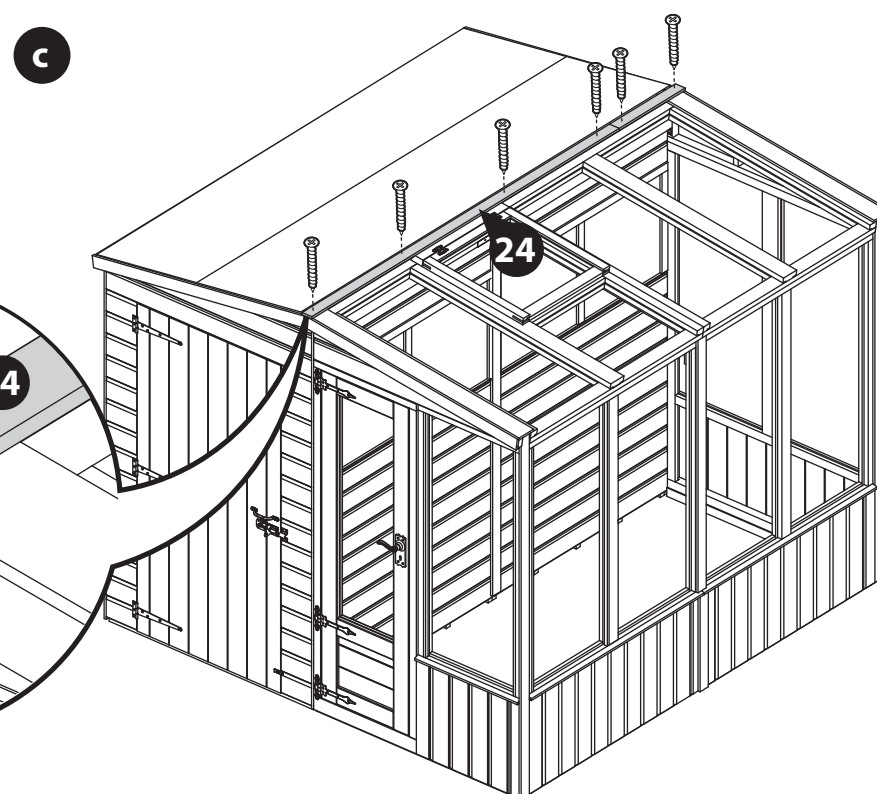
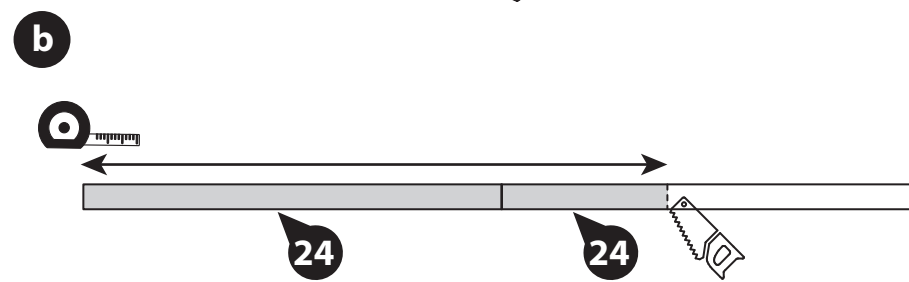
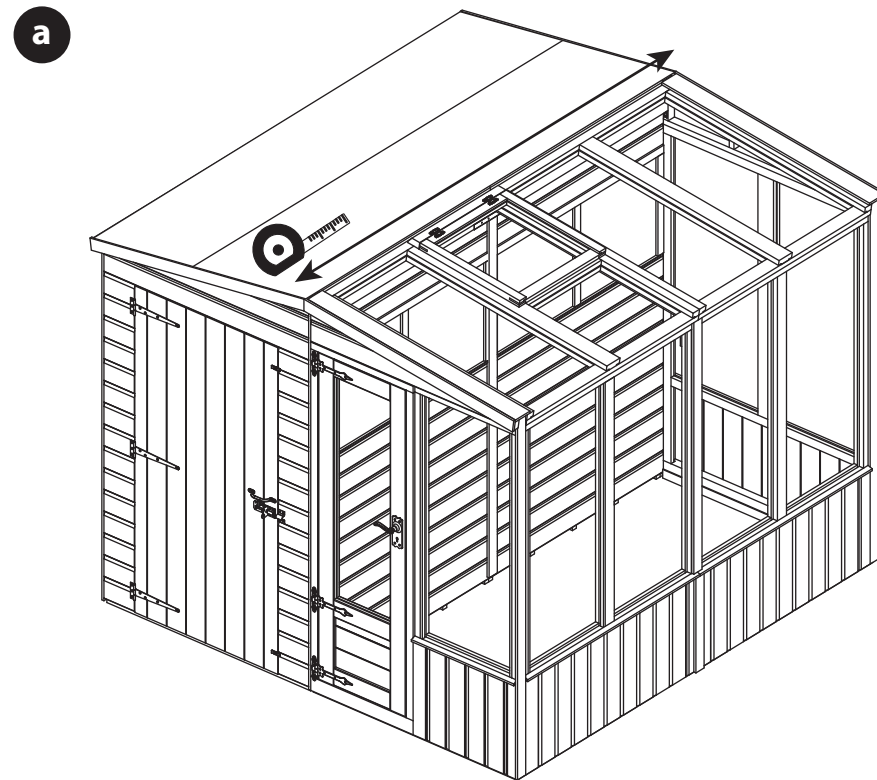

Step 48

Once constructed, apply a preserving treatment and a waterproofing treatment to your garden building as soon as possible. This will help to protect your building and prevent decay.

****Make sure to treat any loose timber components still required for the glazing of your building - such as beading strips.**

See page 37 for a full guide and instructions.

Once fully treated, gently score around the protective covers on the shed window and Greenhouse door glazing, then carefully peel the coverings back.

Please note: the 8x8 'Doors on the end' has been shown for illustrative purposes and may differ from your chosen configuration. However, the process of treating the building is the same for all.



Apply treatment.



Score and peel.

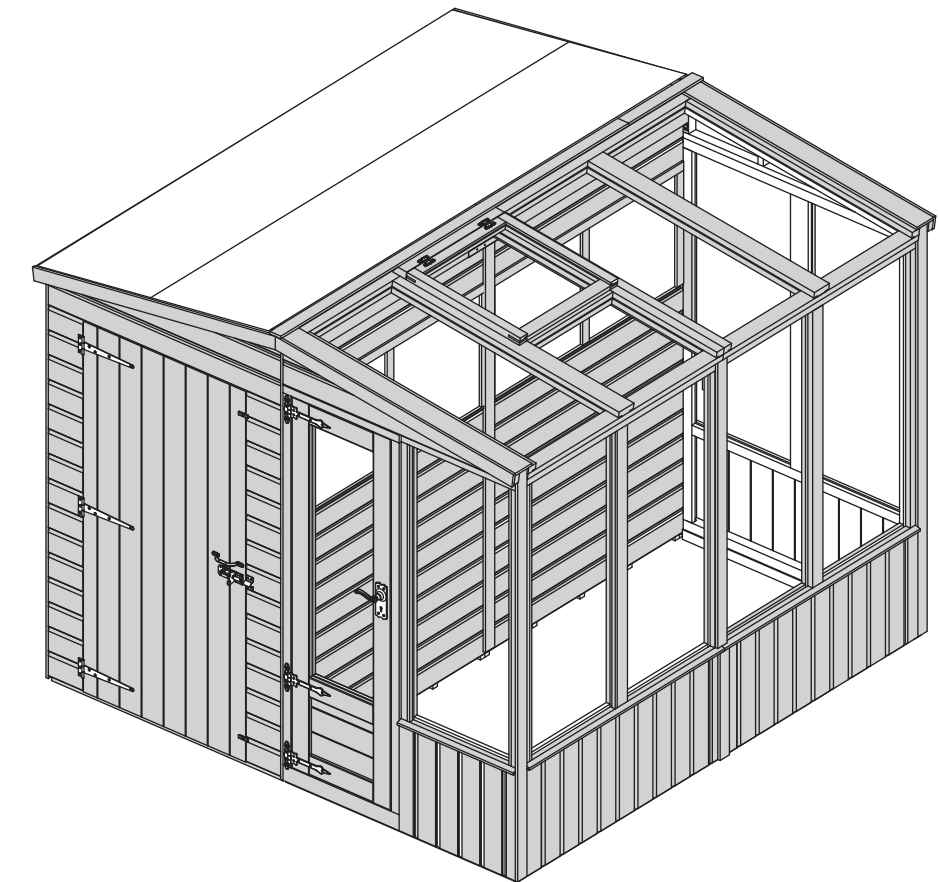
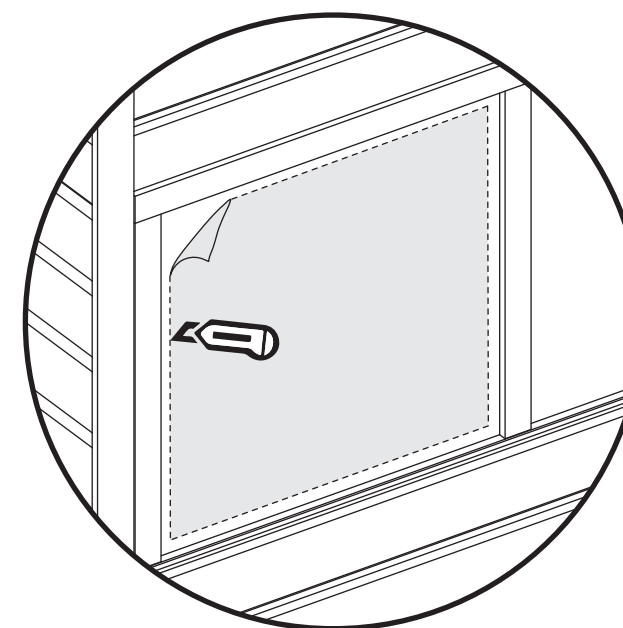

Next steps...

Once your Building is constructed and treated please refer to the 'Panel Glazing' manual provided for steps on how to fit the glazing into each of your panels.

This guide must be followed to complete the construction of your Building.

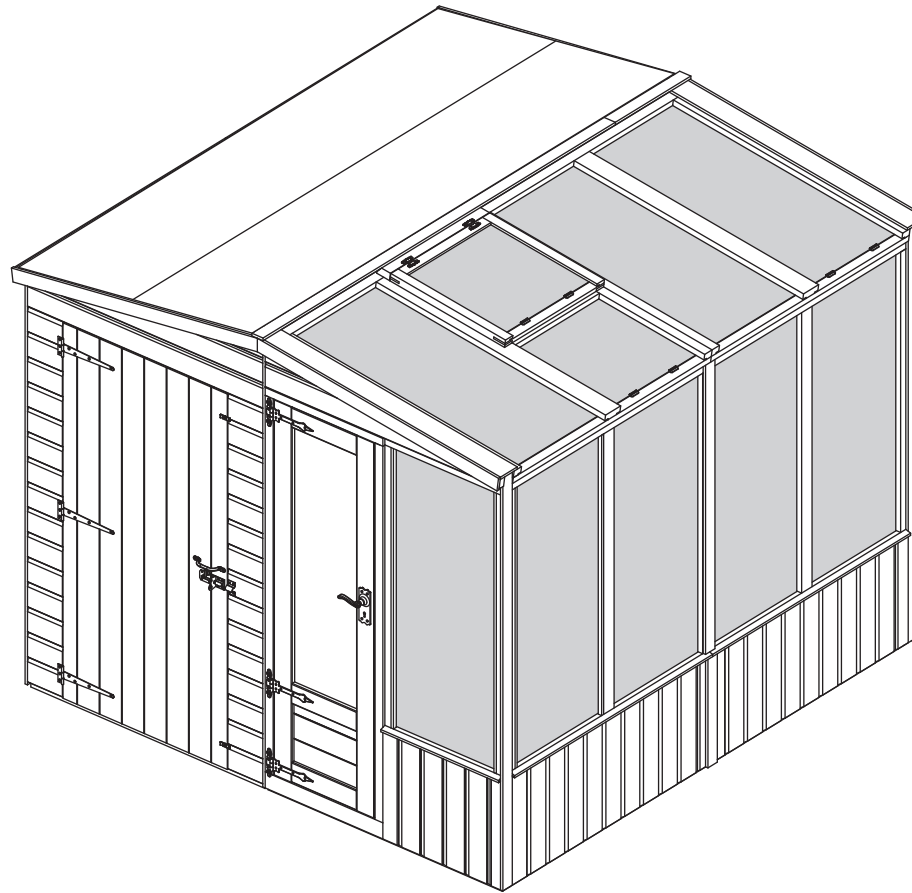

LEAVE US A REVIEW...

Want to share your experience with us?
Leave us a review on Feefo, TrustPilot or Google.

Your reviews help other people find and trust our business, as well as helping to play an important role in our growth and improvement!

TREATING YOUR GARDEN BUILDING

Preservation of wood that's outdoors is vital. A little early care will help protect your garden building, improve its appearance and ensure maximum longevity. Insects, moisture, salt, and changing weather can have dramatic effects on the stability and appearance of your garden building. Once your building is installed, you've checked it over and you're happy with it, you can take a few basic precautions to prepare it for the elements. Treating your garden building helps prevent decay and, by repelling water, discourages the growth of moulds and fungi that could jeopardise the structural integrity of the wood.

Dip Treated buildings - Require a preservative treatment to protect against rot and decay and a waterproof treatment to prevent water ingress
Pressure Treated buildings - Require a waterproof treatment to prevent water ingress
Log Cabins/Insulated Garden Rooms - Are supplied untreated and require a preservative and waterproofing treatment.



ANY QUESTIONS?
Scan the QR code to contact us via our customer portal.

To apply a preservative and water proofing treatment (pressure treated products do not require a preserver), follow the manufacturer's instructions but in principle, stick to the following steps:

- ✓ Weather permitting, ensure to treat your garden building within 14 days of installation.
- ✓ Wear latex or rubber gloves, eye protection and (if spraying) a mask.
- ✓ Prepare the wood, by sanding down any ridges or inconsistencies in the wood, smoothing out knots and end-cuts.
- ✓ Choose a dry day to treat your garden building. If you're spraying rather than brushing paint on, avoid a windy day.
- ✓ Be sure you can safely reach all the sections you need to paint - and if you need a ladder, make sure it's safely positioned before climbing. Lay dust sheets around to avoid paint splatters on your base or surrounding plants.

- ✓ Tape around windowpanes to avoid smears when you're painting the frames.
- ✓ Keep pets and small children out of the way. The last thing you want is to have fur on your garden building paint, or little painted footprints all over your garden and home.
- ✓ Fill any gaps in the building's body with caulk or wood filler to prevent water and draughts getting in. Silicone based caulk is flexible and will move with the timber when temperature and humidity change. Allow to dry completely before treating. A handy tip for finding gaps is to go into your garden building and look for light leaking through joins and frames. If light gets in, then so will water.
- ✓ Liberally apply at least two coats of the treatment products with a brush or spray, taking care to allow the first coat to completely dry before applying the second.
- ✓ Make sure the solution permeates the whole of the surface area, especially around natural cracks, end cuts and nail/screw holes.



APPLY WOOD TREATMENT
IMMEDIATELY
AFTER ASSEMBLY



1 Perimeter

Check around the perimeter of your product to ensure there are not trees or plants that are in contact with or overhanging the building. This can affect airflow and overhanging trees, or branches can damage the roof, it is advised to keep plants at a distance.

2 Repair

Inspect the interior and exterior of the product to look for splits, cracks, and holes. Although this is a natural occurrence it can be prevented. A wood filler can be used to close the splits, cracks, and holes.

3 Roof

Check your roof regularly for tears, splits, damaged wood and fallen debris. If you notice any of this immediate repair is critical.

4 Doors & Windows

Expansion and contraction can cause doors and windows to stick or become difficult to open. Small adjustments to the hinge position can be made to the doors and windows to allow free movement.

5 Oil

Hinges can seize up over time, apply lubricant to the hinges and locks annually.

6 Screws & Bolts

It is advised to check all screws and bolts and tighten any loose you might find. For log cabins specifically the storm braces will require loosening. During humidity and temperature changes (seasons) to allow expansion and contraction to prevent gaping, twisting, popping, and warping.

7 Wash

At least once a year, give the outside of your building a good wash, to remove cobwebs, leaves, or any other dirt that may accumulate on the exterior.

8 Airing

Airing your product regularly prevents the build up of condensation which can cause the timber to warp, bow, boards to pop, distortion, rot and mould. Condensation can build up over time or daily, it is caused by a rise and fall in temperature.

Excessive moisture levels within your building can cause water to collect on the roofs, walls and floors internally. Leaving doors and windows open regularly can help combat the natural moisture build up.

9 Clean & Tidy

It is good practice to clean the inside and outside of your product regularly. Clear out the contents, sweep the floor, remove dirt and cobwebs. Check for areas of damp and investigate the cause to remove and prevent future occurrences. Check the ground around your product for build up of debris such as leaves, remove and ensure there is clear ventilation underneath the floor.

All our garden buildings have been designed and manufactured with care and attention to be the perfect addition to your outdoor space. To ensure you do get the best out of your new garden building and to increase the longevity we advise that you follow the product instructions and our manufacturer's recommendations as detailed below. Thank you for choosing a Mercia Garden product!

1 Choosing the most suitable location for your garden building...

A minimum of 60cm should be left around the perimeter of your garden building to allow access for maintenance, annual treatment and to allow air flow around the building.

Where possible you should avoid placing your garden building underneath large trees to prevent the tree causing damage to the building.

2 Preparing the base for your garden building...

All our buildings must be built on a firm, level base to ensure the longevity of the building and prevent the wood from distorting. We recommend either concrete, concrete slabs or a wooden base, such as our 'Portabase'.

The base should be slightly smaller than the external measurement of the building, i.e. the cladding should overlap the base, creating a run off for water and preventing water from pooling underneath the building.

We also recommend that the floor of the garden building is a minimum of 25mm above the surrounding ground level to avoid flooding.

3 After installation...

Once your garden building has been installed, it will need to be treated within 14 days (weather permitting) and annually to prevent the timber from deteriorating and to waterproof it. This is required to maintain the anti-rot guarantee.

Dip Treated buildings - Require a preservative treatment to protect against rot and decay and a waterproof treatment to prevent water ingress.

We also recommend using a silicon sealant around the glazing on the inside and outside of the windows and roofs as soon as possible after assembly and treatment to fully seal the windows.

Roofing felt/covering should be checked annually and replaced or fixed accordingly.

4 General maintenance and wood characteristics

As wood is a natural material it may be affected by the following:

Shrinkage and warping - The timber used in the construction of your garden building will have retained some of its natural moisture content. The moisture content of the timber will vary, depending upon prevailing environmental conditions, which will result in the components either naturally expanding or contracting. As the components dry out, shrinkage may occur. A good waterproofing treatment from the start is the best protection to minimise the effect of moisture loss/intake.

In extended periods of very warm weather getting some moisture to the building will help the overall balance. You can do this by spraying it down lightly with a garden hose. In contrast, after snow fall try to remove the snow as best as possible from the roof to prevent moisture intake and to remove the extra weight.

Top tip - using a garden brush will help you to reach the highest part of the building to remove snow and any debris left from bad weather.

Damp and mould - During the winter months, cold and damp conditions can result in an increased amount of moisture within your garden building, especially when used infrequently. Condensation can form on the timber and other items stored within your garden building. If left this moisture is likely to cause mould and mildew.

To prevent the build-up of moisture, we recommend leaving the door or windows of your building open from time to time, to allow the fresh air to circulate. We also advise against storing wet or damp items in your garden building as this will also increase the level of moisture in the building. If mould or mildew does start to form within your building we recommend using an anti-mould cleaner to remove it and to prevent it spreading, which if left untreated could permanently damage your garden building.

Splits, cracks and knots - You may notice small splits and cracks in some components or holes may appear where knots shrink and fall out. This will not affect the structure of your Garden building however, if you wish to fill them this can be easily done using any good quality wood filler.

Sap - is naturally occurring in wood and may appear in some boards of your garden building. If you wish to remove the sap, we advise waiting until it is dry and then using a sharp knife to carefully remove it. If the removal of the sap causes a hole in the timber, we recommend using a good quality wood filler to fill it.



Any further questions?

Contact our Customer Service Team via the MGP Customer Portal at: www.mgplogistics.co.uk

For more handy hints and tips on how to care and maintain your garden building please refer to the MGP Customer Portal at: www.mgplogistics.co.uk

1 Manufacturer's Warranty

All Mercia Garden Products are supplied with a 1 year warranty on all parts against manufacturing defects. This warranty does not cover movement, warping or splitting of timber products over time.

This warranty will be voided if any of the following occur:

1. The building has been customised or modified/adapted in any way.
2. The person claiming is not the original purchaser of the building.
3. Any damage has been caused by or as a result of misuse.
4. The building has not been maintained and cared for in accordance to our advisories and manufacturer's recommendations.
5. The building has not been treated annually or as per the manufacturer's recommendations, please ensure receipts are kept to validate this claim.
6. The building has not been erected, fitted or installed as per the supplier instructions.
7. The building has not been erected on a suitable sized firm flat, solid level concrete/slab base or placed on pressure treated bearers.
8. The building is or has been placed with 2 feet (600mm) of any obstructions (walls, trees, plants, fences etc.) which can allow moisture to penetrate the timber.
9. The roofing felt has been incorrectly fitted or damaged, allowing water ingress, or has not been properly maintained.
10. Any windows and joints have not been sealed, inside and out, with silicone or other watertight sealant.
11. Any timber has been cut, pierced or drilled without subsequent application of approved cut-end treatment.

REGISTER FOR YOUR
15 YEAR
ANTI-ROT
GUARANTEE TODAY

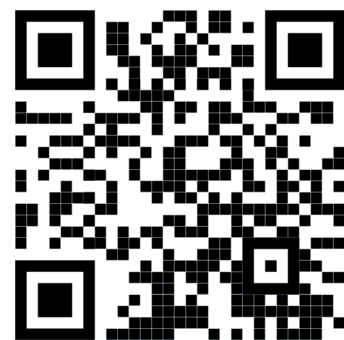

www.mgplogistics.co.uk

2 Anti-rot Guarantee

Mercia Garden Products offer a 15 year anti-rot guarantee on dip treated (a preparatory treatment) and 20 years on pressure treated products within this range. This guarantee covers solid timber against rot, decay, blue stain and insect attacks.

To validate the guarantee, the building must be treated (as detailed within manufacturer's recommendations) within 14 days (weather permitting) of assembly and annually thereafter. This guarantee does not cover movement, warping or splitting of timber products over time.

This guarantee will be voided if any of the following occur:

1. The building has been customised or modified/adapted in any way.
2. The person claiming is not the original purchaser of the building.
3. Any damage is caused by or as a result of misuse.
4. The building has not been maintained and cared for in accordance to our advisories and manufacturer's recommendations.
5. The building has not been treated annually or as per the manufacturer's recommendations, please ensure receipts are kept to validate this claim.
6. The building has not been erected, fitted or installed as per the supplier instructions.
7. The building has not been erected on a suitable sized firm flat, solid level concrete/slab base or placed on pressure treated bearers.
8. The building is or has been placed with 600mm of any obstructions (walls, trees, plants, fences etc.) which can allow moisture to penetrate the timber.
9. The roofing felt has been incorrectly fitted or damaged allowing water ingress, or has not been properly maintained.
10. Any windows and joints have not been sealed, inside and out, with silicone or other watertight sealant.
11. Any timber has been cut, pierced or drilled without subsequent application of approved cut-end treatment.