

10DTSHPN0804-V1

8X4 SHIPLAP PENT DOG KENNEL / RUN.

BEFORE YOU START PLEASE READ INSTRUCTIONS CAREFULLY

- Check the pack and make sure you have all the items listed in the parts list provided.
- When you are ready to start, make sure you have the right tools at hand (not supplied - see the equipment list on next page).
- Ensure there is plenty of space and a clean dry area for assembly.
- Ensure you have enough time to build the product to ensure the building is water tight.

LOCATION FOR YOUR GARDEN BUILDING

A minimum of 600mm should be left around the perimeter of your garden building to allow access for maintenance, annual treatment and to allow air flow around the building.

Where possible you should avoid placing your garden building underneath large trees to prevent the tree causing damage to the building.

TIMBER

As with all natural materials, timber can be affected during various weather conditions. For the duration of heavy or extended periods of rain, swelling of the wood panels may occur. Warping of the wood may also occur during excessive dry spells due to an interior moisture loss. Unfortunately, these processes cannot be avoided but can be helped. It is suggested that the outdoor building is sprayed with water during extended periods of warm sunshine and sheltered as much as possible during rain or snow.

Once your garden building has been installed it will need to be treated within 14 days (weather permitting) and annually to prevent the timber from deteriorating and to waterproof it. This is required to maintain the anti-rot guarantee.

Dip Treated buildings - Require a preservative treatment to protect against rot and decay and a waterproof treatment to prevent water ingress

Pressure Treated buildings - Require a waterproof treatment to prevent water ingress

Log Cabins/Insulated Garden Rooms - Are supplied untreated and require a preservative and waterproofing treatment.

BUILDING A BASE

When thinking about where the building and where the base is going to be constructed: Ensure that there will be access to all sides for maintenance work and annual treatment.

Ensure the base is level and is built on firm ground, to prevent distortion. Refer to diagrams for the base dimensions, The base should be slightly smaller than the external measurement of the building, i.e. The cladding should overlap the base, creating a run off for water. It is also recommended that the floor be at least 25mm above the surrounding ground level to avoid flooding.

TYPES OF BASE

- Concrete 75mm laid on top of 75mm hard-core.
- Slabs laid on 50mm of sharp sand.
- Wooden base.

Whilst all products manufactured are made to the highest standards of safety and in the case of children's products independently tested to EN71 level, we cannot accept responsibility for your safety whilst erecting or using this product.



x2

All buildings should be erected by two adults



Winter = High Moisture = Expansion
Summer = Low Moisture = Contraction



2mm Drill bit

For ease of assembly, you **MUST** pilot drill all screw holes and ensure all screw heads are countersunk.



CAUTION

Every effort has been made during the manufacturing process to eliminate the prospect of splinters on rough surfaces of the timber. You are strongly advised to wear gloves when working with or handling rough sawn timber.



For ease of assembly, you will need a tape measure to check dimensions of components.

Screws & Nails



Measure overall length

Bolts

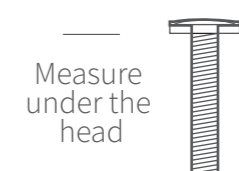

Measure under the head

To identify the fixings required for each step use a measuring tape.

Protim Aquatan T5 (621)

Your building has been dip treated with Aquatan.

Aquatan is a water-based concentrate which is diluted with water, the building as been treated by the correct application of Aquatan solution and then allowed to dry.

Aquatan is a decorative finish to colour the wood, which is applied industrially to timber fence panels and garden buildings.

Aquatan undiluted contains: boric acid, sodium hydroxide 32% solution, aqueous mixture of sodium dioctyl sulphosuccinat and alcohols: 2, 4, 6-trichlorophenol.

REGISTER FOR YOUR ANTI-ROT GUARANTEE TODAY

PLEASE SCAN HERE:

In all instances for assistance with your product, please contact us via our customer portal: <https://www.mgplogistics.co.uk/>.

Mercia Garden Products Limited,
Sutton On Trent,
Newark,
Nottinghamshire,
NG23 6QN

TO DO LIST

- Find a suitable location to build *(see front cover for further information).*
- Build a base *(see front cover for further information).*
- Check the base is flat, level, clear of debris and has 60cm clearance on all sides.
- Check you have the required equipment.
- Check you have all the product items listed *(if you have missing or damaged parts please contact the customer services department, see front cover for contact details).*
- Install the product as per the step by step instructions within this pack.
- Prepare the product ready for treatment.
- Apply a preserving and a waterproofing treatment within 14 days *(weather permitting)* of installation *(pressure treated products do not require a preserver).*
- Register for your anti rot guarantee *(scan the QR below).*
- Tidy the build area and dispose of any remaining parts responsibly.
- Maintain your building *(see the manufacturers recommendations at the back of this pack).*

EQUIPMENT LIST

- Hammer
- Flat Head Screwdriver
- Drill
- Drill Bit Set
- Phillips and Slotted Bit Sets
- Tape Measure
- Hand Saw
- Spirit Level
- Ladders/Steps
- Stanley Knife/Cutting Tool
- Sand Paper
- Gloves
- Silicone (For Windows Only)
- Wood Filler (Optional)
- Timber Preservative Treatment *(not pressure treated products)*
- Timber Water Proofing Treatment
- Treatment Mixing Stick
- Paint Brush/Sprayer/Roller

NEED EXTRA SUPPORT

If you are unsure that your base preparation will be suitable, please contact us on 01636 821215 to discuss this further.

Alternatively, you can visit our website or MGP Logistics Online Portal for some further shededucation.

Website:

<https://www.merciagardenproducts.co.uk/sheducation>

MGP Logistics Online Portal:

<https://www.mgplogistics.co.uk/>

Here you will find plenty of useful information that'll help with most pre-installation and maintenance queries.

PLEASE SCAN HERE:



ANY QUESTIONS?

Scan the QR code to contact us via our customer portal.

NOTES

ACCESSING VIDEO GUIDES...

Some steps within this set of instructions come with an added video guide for your convenience. These can be accessed via the QR code and used to aid you in constructing that step. See below for how to use.

You can also find all the videos on our youtube channel:
<https://www.youtube.com/@merciagardenproducts8716/videos>

1. Find the QR code within the instruction step...

Step.....

Parts Needed- No. QTY 1
No. QTY 1
No. QTY 1



Within the instruction step, there will be an icon in the top right that has a QR code in. This is where the video can be accessed from.

Please note: not every step has a video guide.

2. Open camera app...

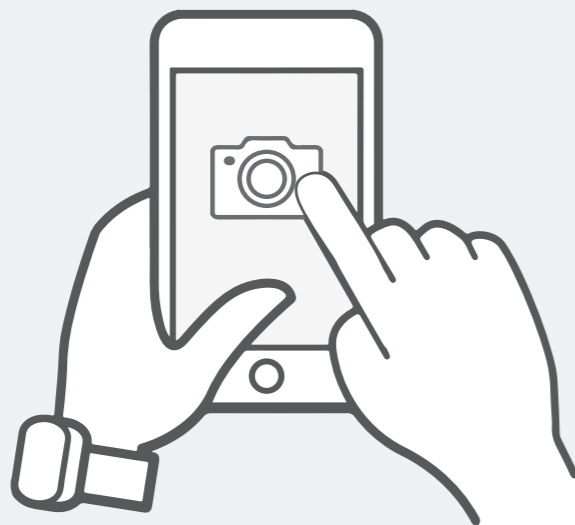

On your personal smart device (phone, tablet etc), open your camera app or QR code scanner app.

ACCESSING VIDEO GUIDES...

3. Scan QR code...



To scan the QR code, hold the camera over the QR code so that it can be seen on the screen. Once the QR code has been registered, follow the prompts on your device to open the video. (This will vary depending on your device.)

Please note: Ensure to use the back camera of your smart device as this will scan the QR code more accurately.

4. Watch the video...



The video guide will now be displayed on your smart device.

Disclaimer: The garden building constructed in the video guides may be constructed differently to your building. Please ensure to read your instructions carefully to avoid error.

Before assembly
please make sure you have a
suitable base ready to erect your
building

MADE IN GREAT BRITAIN

Overall Dimensions: Width = 2310mm
Depth = 1217mm
Height = 1277mm

Base Dimensions: Width = 2258mm
Depth = 1132mm

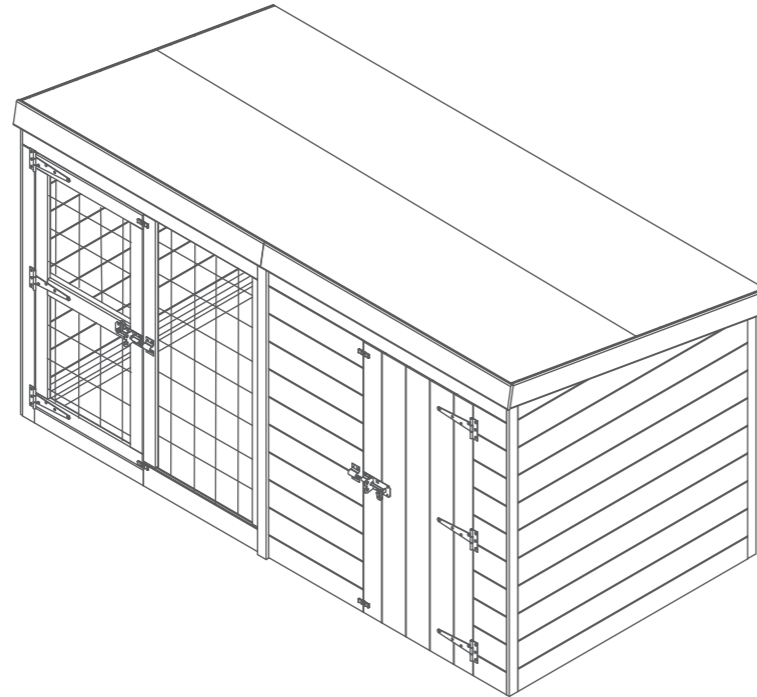

9

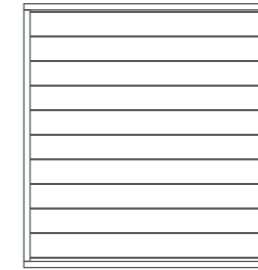

Roof Panel QTY 2
AI-S11MBPR1143X1202-V1

10

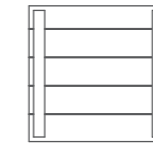

Floor Tile QTY 4
AI-S22MBF548X535-V1

11



Fascia - 12x95x1270mm QTY 4
S1295-1270mm

12



Cover Trim - 12x40x1218mm 6TY 6
S1240-1218mm

13



Base Frame A - 44x44x1126mm QTY 3
F4444-1126mm

14



Base Frame B - 44x44x1066mm QTY 1
F4444-1066mm

15



Base Frame C - 44x44x519mm QTY 2
F4444-519mm

16



Base Frame D - 44x44x1060mm QTY 1
F4444-1060mm

17



Centre Framing - 28x28x1085mm QTY 1
FS2828-1085mm

18

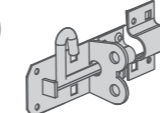

Pad bolt QTY 2
PI-07-0035

19

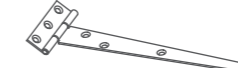

T-hinge QTY 6
PI-07-0082

20



Turn button QTY 4
PI-07-0034

21



Felt QTY 1

1

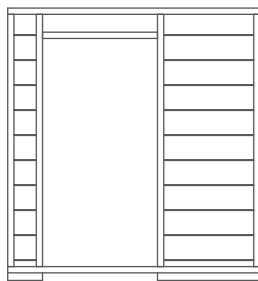

Door Panel QTY 1
AI-10S11MBSD1130X1220-V1

2

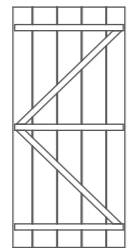

Door QTY 1
AI-S11FBMBZBD510X1095-V1

3

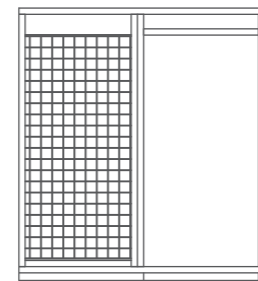

Mesh Door Panel QTY 1
AI-10S11MESSD1130X1220-V1

4

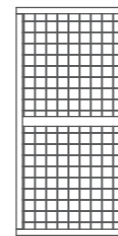

Mesh Door QTY 1
AI-10S11MESLFD499X1021-V1

5

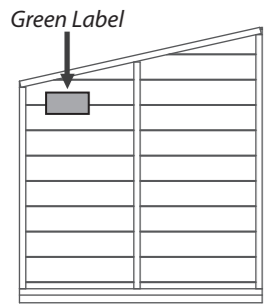

Right Gable QTY 1
AI-10S11MBPGR1074X1220-V1

6

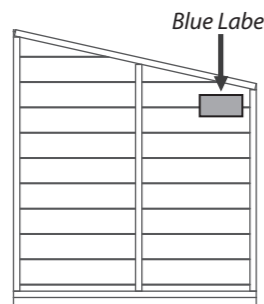

Left Gable QTY 1
AI-10S11MBPGL1074X1220-V1

7

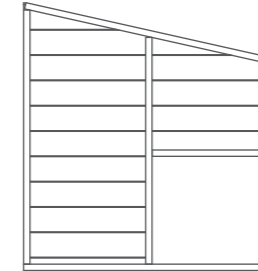

Centre Gable QTY 1
AI-10S11MBGOP1074X1220-V1

8



Back Panel QTY 2
AI-S11MBPP1130X1024-V1

2X4 Extension Pack B.
10DTSHPN0204PB-V1

If you have purchased a 12x4 building then you will have double the amount of each item in pack B

Overall Dimensions: Width = 2875mm
Depth = 1217mm
Height = 1277mm

Base Dimensions: Width = 2821mm
Depth = 1126mm

10X4

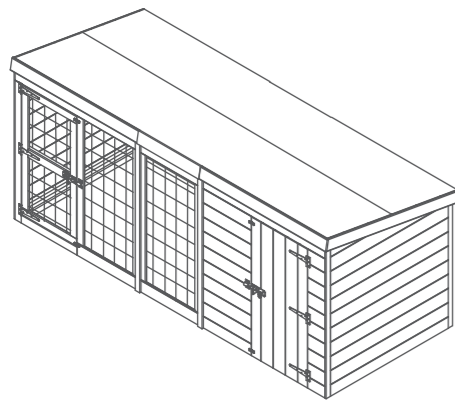

Overall Dimensions: Width = 3438mm
Depth = 1217mm
Height = 1277mm

Base Dimensions: Width = 3384mm
Depth = 1126mm

12X4

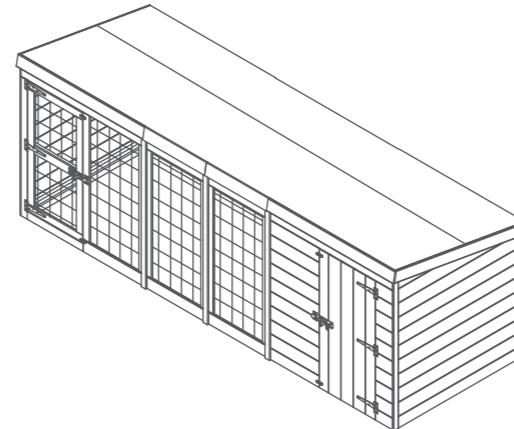

Contents:

22

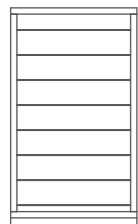

Small Back Panel QTY 1
AI-S11MBPP565X1024-V1

23

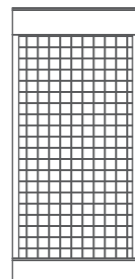

Mesh Panel QTY 1
AI-10MESSP565X1220-V1

24



Roof Panel QTY 1
AI-S11MBPR565X1202-V1

25



Cover Trim - 12x40x1218mm QTY 2
S1240-1218mm

26



Base Framing - 44x44x563mm QTY 2
F4444-563mm

27

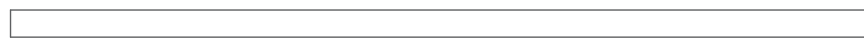

Framing - 28x28x1623mm QTY 1
FS2828-1623mm

28



Fascia- 12x95x565mm QTY 1
S1295-565mm

If you have purchased a 2ft Extension pack B, please follow instructions for '10x4 Extension pack B' or '12x4 Extension pack B' where relevant.

Nail Bag

There may be extra screws present in the nail bag.



70mm Screw x 18



30mm Screw x 96



60mm Screw x 38



20mm Screw x 20



50mm Screw x 24



Felt Tacks x 105



40mm Screw x 51

Pre Assembly

Before assembling remove the transportation blocks from the bottom of each panel.

Take care removing the blocks as to not damage the panels. Tap with a flat headed screwdriver and hammer.

Dispose of the blocks once removed.

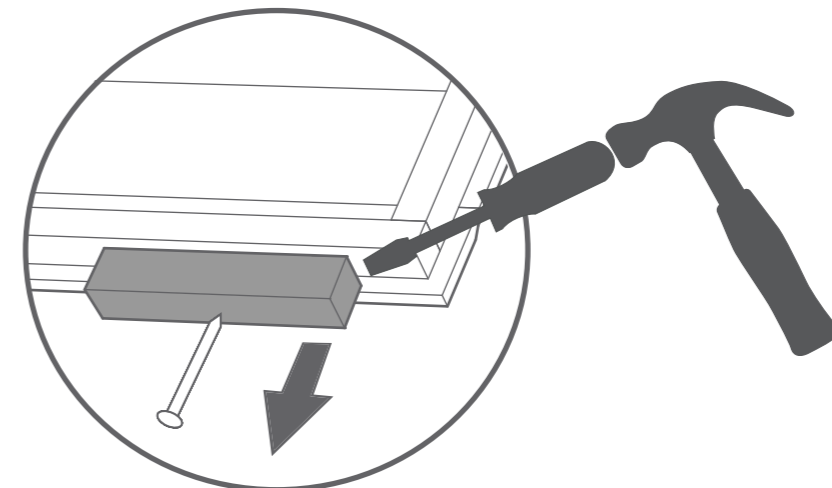

PLEASE SCAN HERE:



Step 1

- Parts Needed - No. 13 QTY 2**
- No. 15 QTY 1
- No. 14 QTY 1

Construct the Base using Base Framing A (No. 13), B (No. 14) & C (No. 15). This will create a base for the Kennel area.

Fix the Framing together with 2x70mm screws per corner.

6x70mm screws.

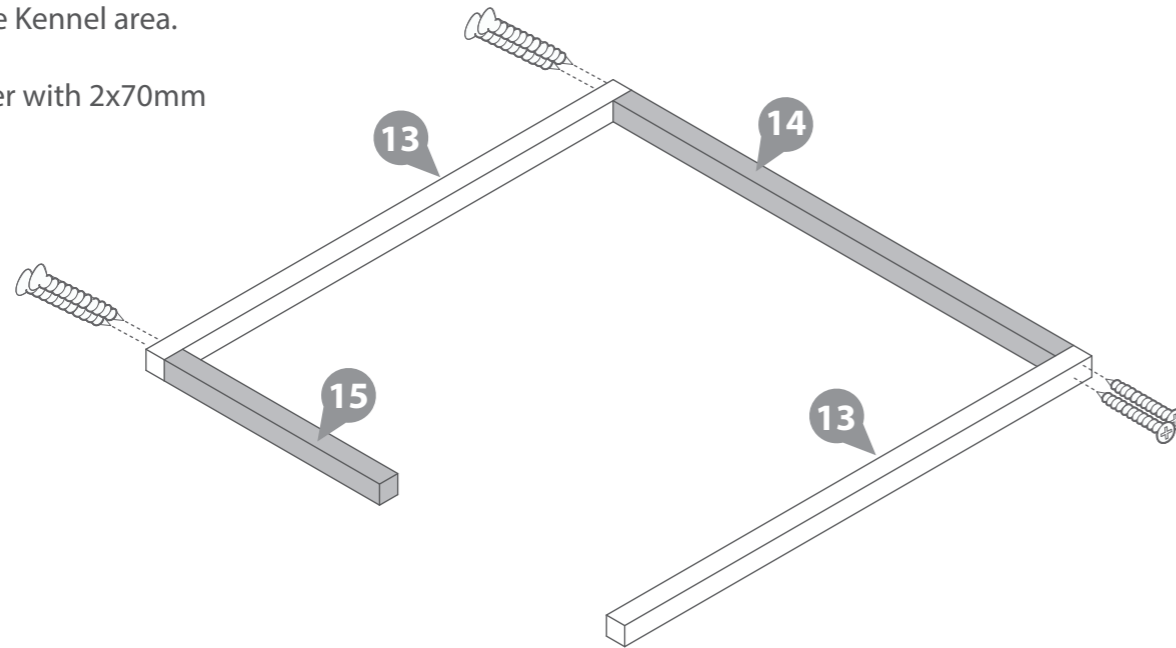
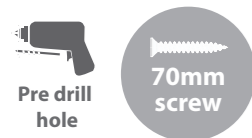

IMPORTANT: Pre-drill before fixing screws.

Step 3

- Parts Needed - No. 1 QTY 1**

Locate the Door Panel (No. 1) onto the base framing. Ensure there is equal spacing between the base framing and the panels.

Fix the Door Panel to the Right Gable using 3x40mm screws.

3x40mm screws.

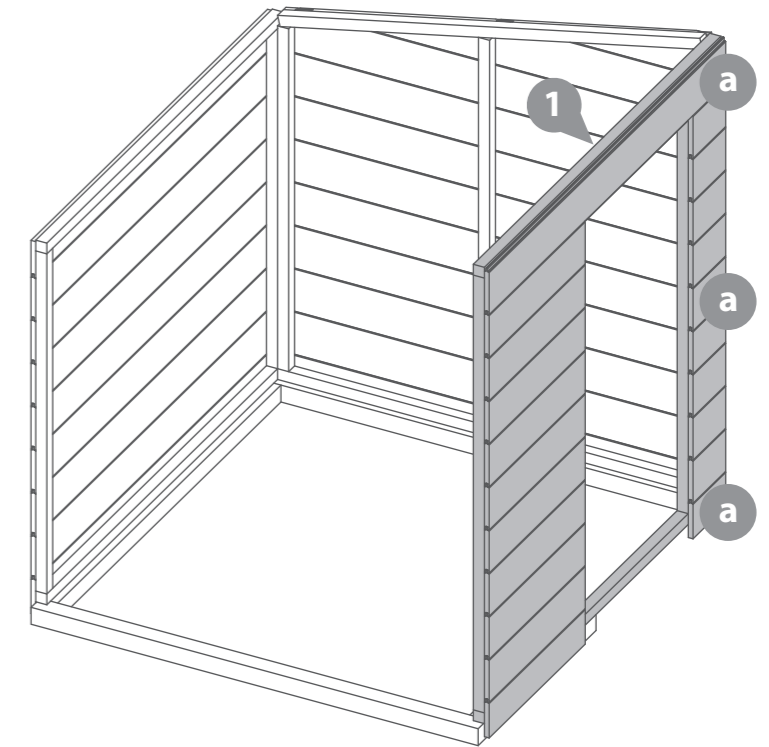
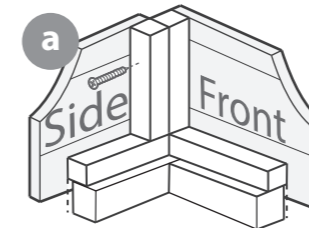
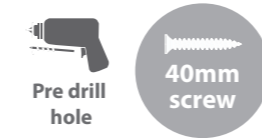

IMPORTANT: Pre-drill before fixing screws.

Step 2

- Parts Needed - No. 5 QTY 1**
- No. 8 QTY 1

Place the Right Gable (No. 5) and the Back Panel (No. 8) onto the base framing and fix together with 3x40mm screws through the framing.

****Do NOT fix to the base framing until the Roof is secured****

3x40mm screws.

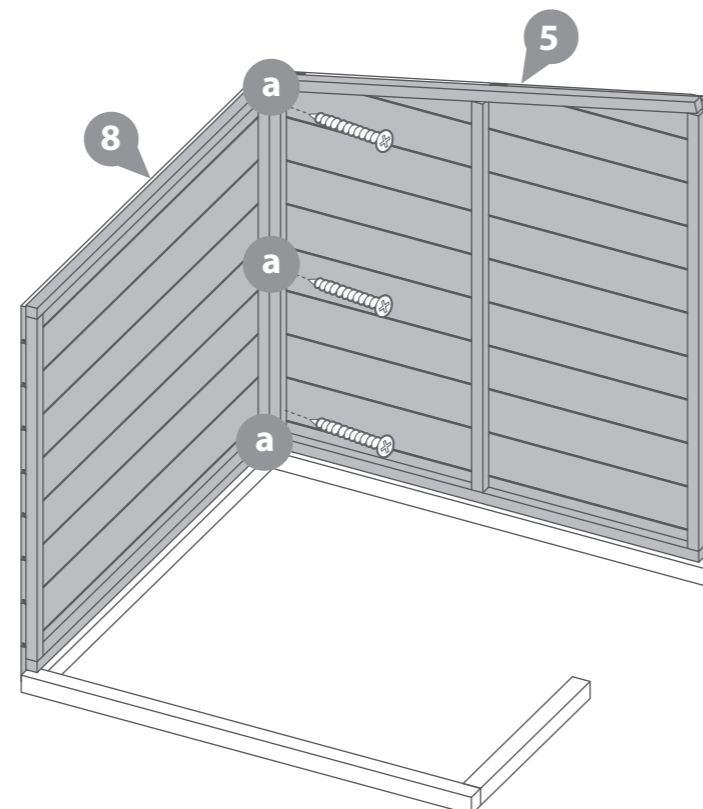
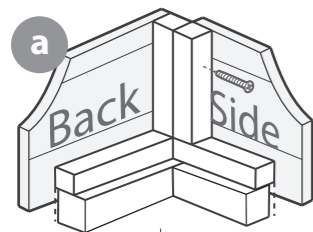
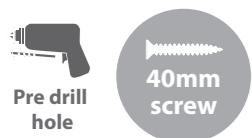

IMPORTANT: Pre-drill before fixing screws.

Step 4

- Parts Needed - No. 13 QTY 1**
- No. 15 QTY 1
- No. 16 QTY 1

Place the remaining Base Framing (No.13, 15 & 16) into position as shown and secure with 2x70mm screws through the corners.

The Run base framing does not fix to the Kennel area

Please note: The base framing will be secured further once all the panels are fitted.

4x70mm screws.

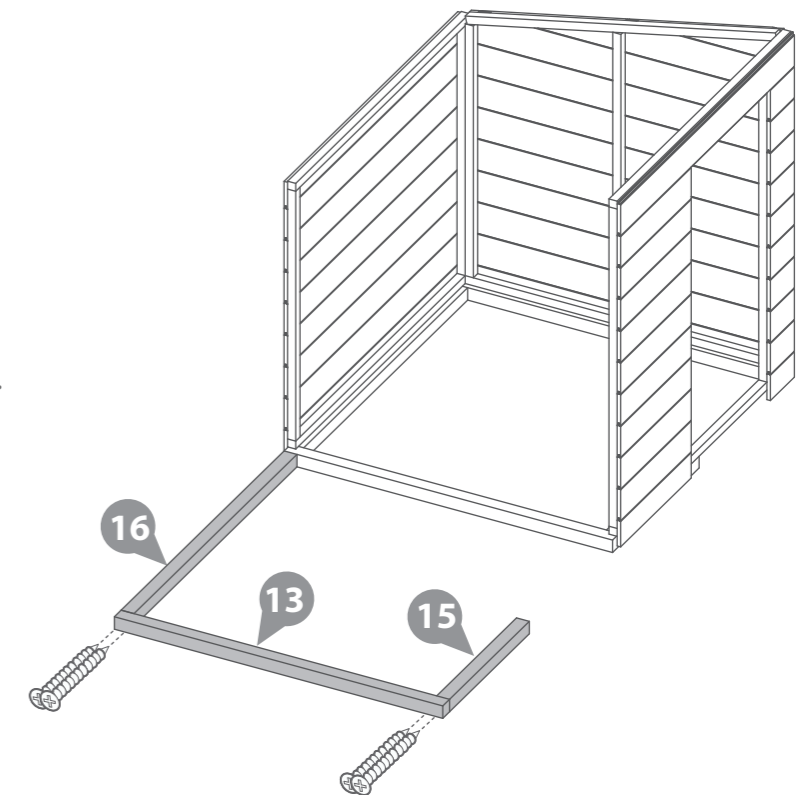

IMPORTANT: Pre-drill before fixing screws.

Step 4a - 10x4 EXTENSION PACK B

IMPORTANT: Pre-drill before fixing screws.

- Parts Needed - No. 13 QTY 1 - No. 26 QTY 2**
- No. 15 QTY 1 - No. 27 QTY 1
- No. 16 QTY 1

Place the remaining Base Framing (**No.13, 15, 16, & 26**) into position as shown and secure with 2x70mm screws through the corners.

Locate the Framing (**No.27**) against the base framing as shown. Ensure the framing is level and flush.

Fix in place using 3x70mm screws, going through the framing into the bearers behind.

The Run base framing does not fix to the Kennel area

Please note: The base framing will be secured further once all the panels are fitted.

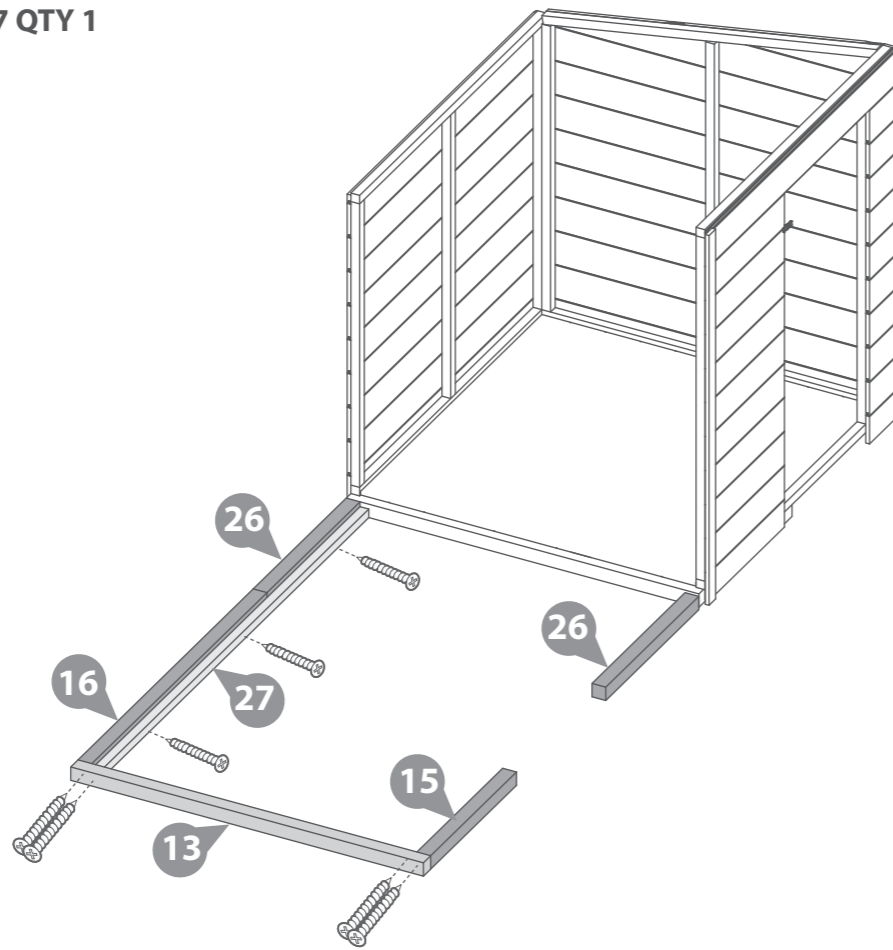

7x70mm screws.

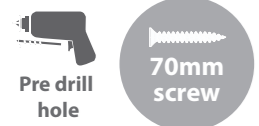

Step 4b - 12x4 EXTENSION PACK B

IMPORTANT: Pre-drill before fixing screws.

- Parts Needed - No. 13 QTY 1 - No. 26 QTY 4**
- No. 15 QTY 1 - No. 27 QTY 1
- No. 16 QTY 1

Place the remaining Base Framing (**No.13, 15, 16, & 26**) into position as shown and secure with 2x70mm screws through the corners.

Secure the front two Base Frames (**No.26**) together using 1x70mm screws, screwing through the bearer at an angle into the next.

Locate the Framing (**No.27**) against the base framing as shown. Ensure the framing is level and flush.

Fix in place using 3x70mm screws, going through the framing into the bearers behind.

The Run base framing does not fix to the Kennel area

Please note: The base framing will be secured further once all the panels are fitted.

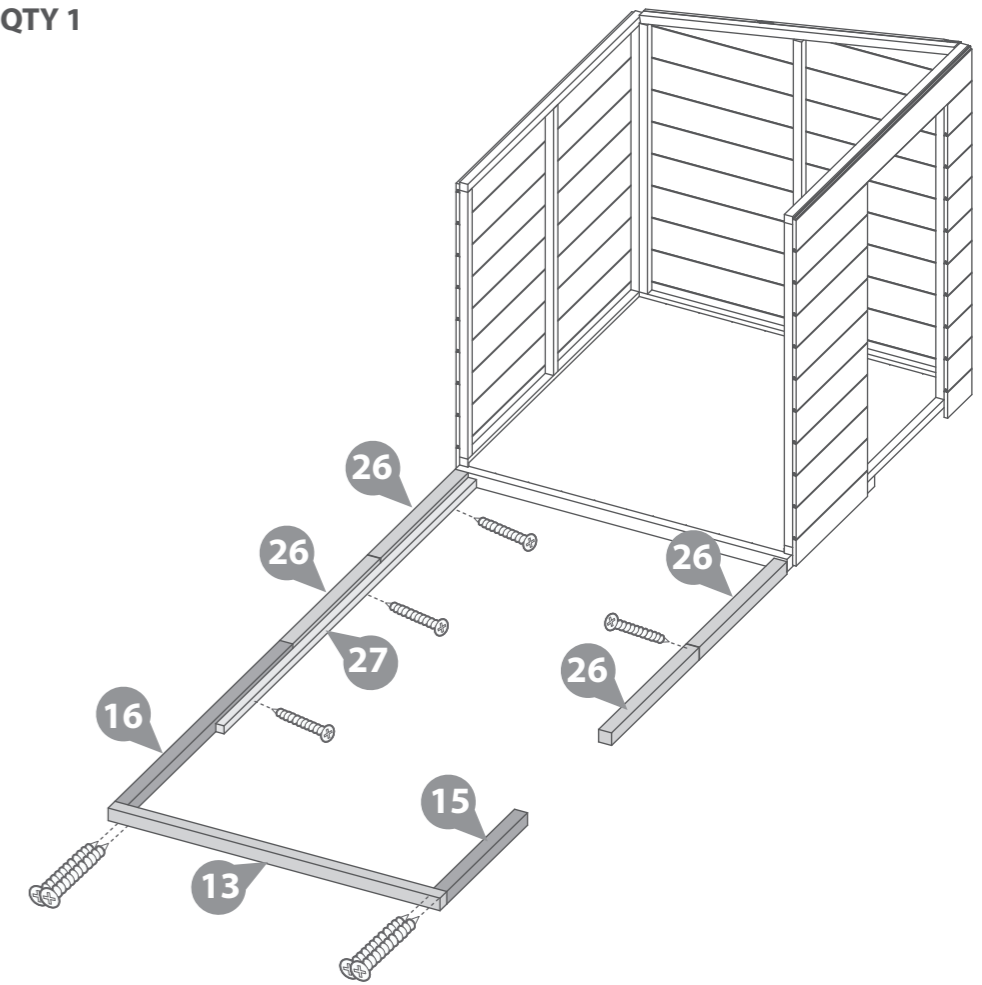

8x70mm screws.



Step 4c - EXTENSION PACK B's.

10x4
Parts Needed - No. 22 QTY 1
- No. 23 QTY 1

12x4
Parts Needed - No. 22 QTY 2
- No. 23 QTY 2

Locate the Small Back Panel (**No. 22**) onto the back of the base frame and the Mesh Panel (**No. 23**) onto the front of the base frame, as shown.

Secure the panels to the adjacent panels using 3x40mm screws per panel.

****Do NOT fix to the base framing until the Roof is secured****

10x4
6x40mm screws.

12x4
12x40mm screws.

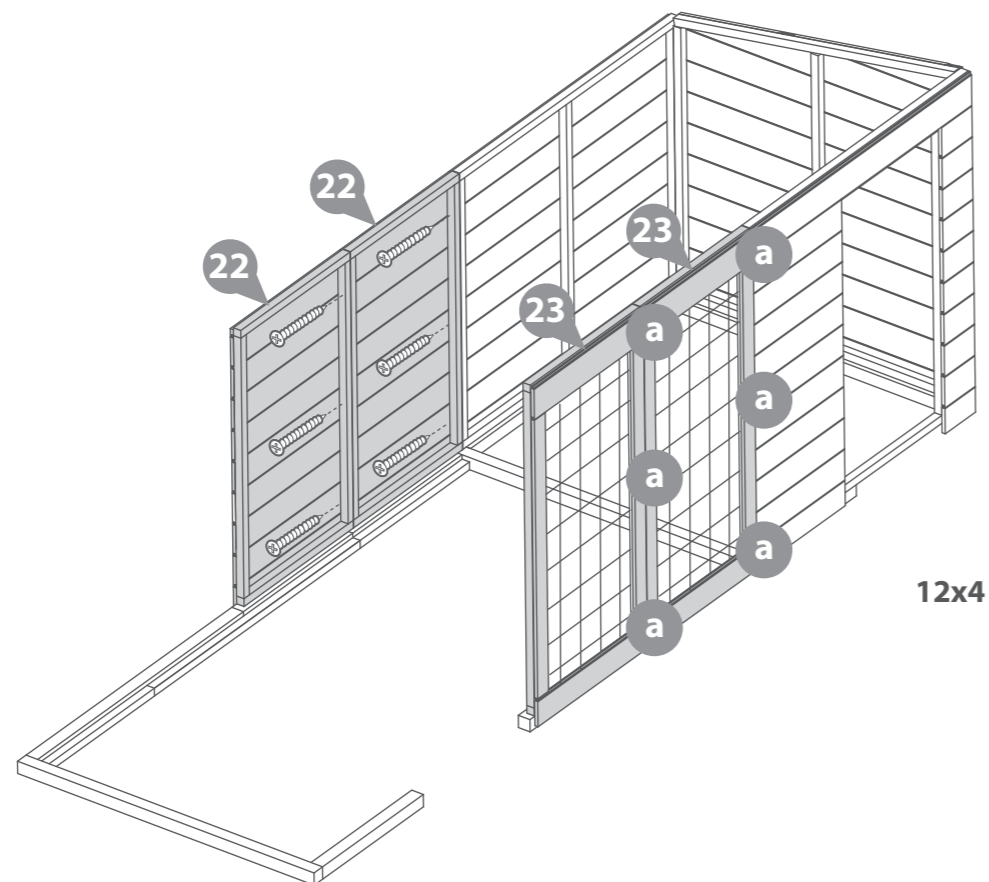
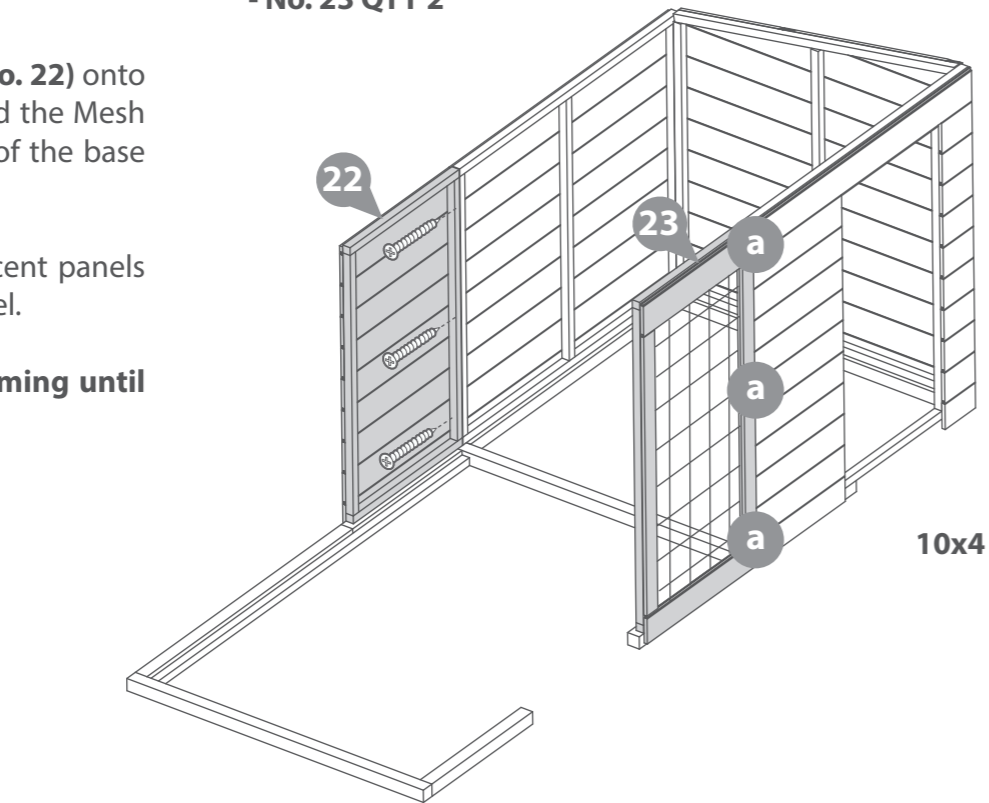
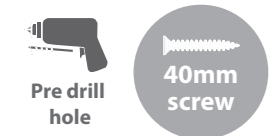

IMPORTANT: Pre-drill before fixing screws.

Step 5

Parts Needed - No. 3 QTY 1
- No. 8 QTY 1

Locate the remaining Back Panel (**No. 8**) and the Mesh Door Panel (**No. 3**) on top of the base framing as shown.

Secure in place using 3x40mm screws per panel.

****Do NOT fix to the base framing until the Roof is secured****

6x40mm screws.

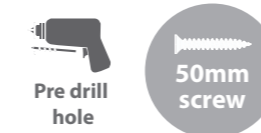

IMPORTANT: Pre-drill before fixing screws.

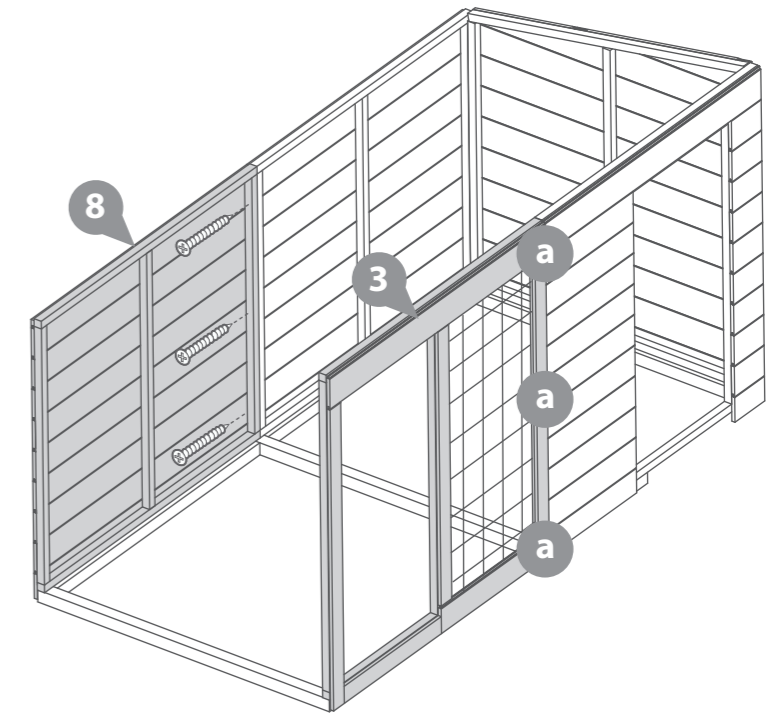

EXTENSION PACK B's:

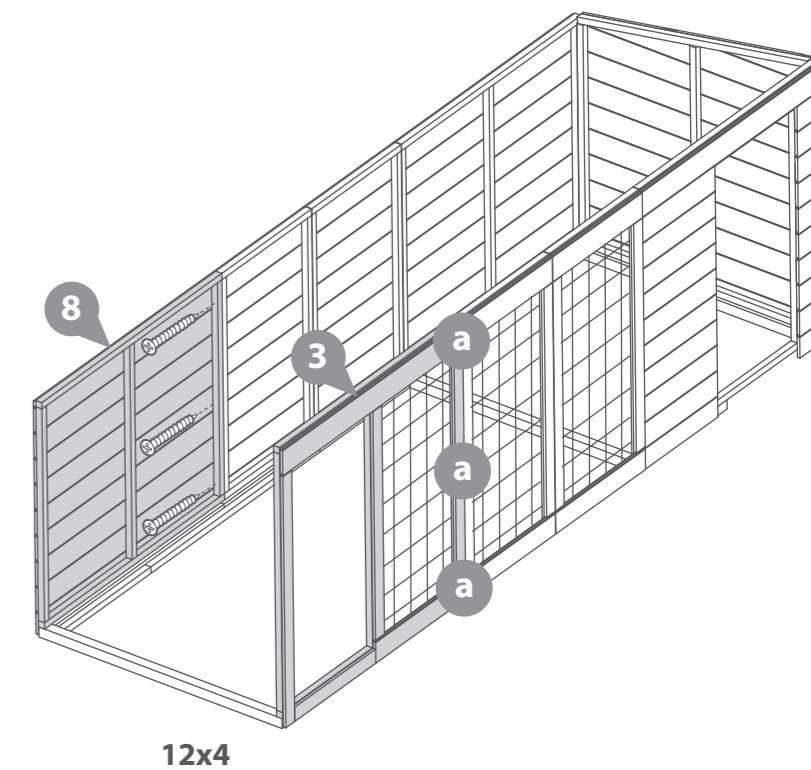
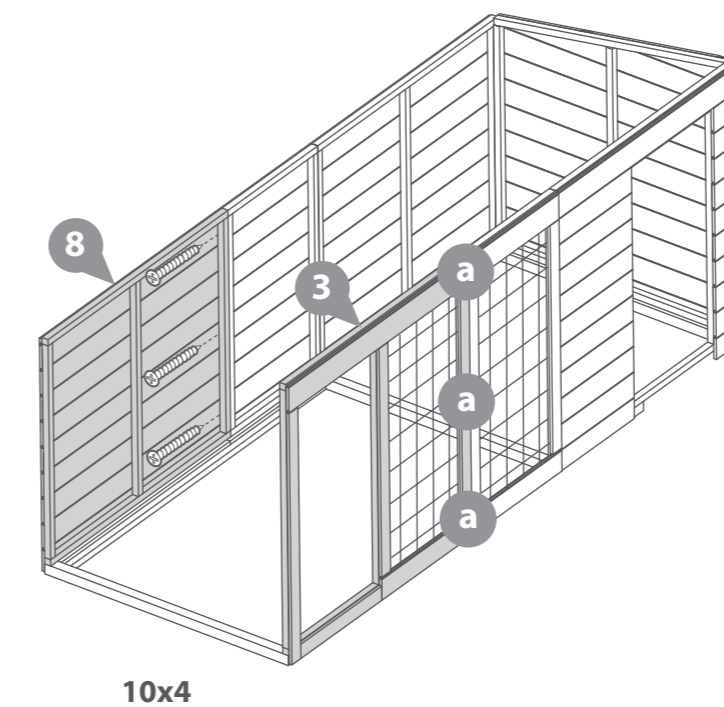

Step 6
Parts Needed - No. 7 QTY 1

Place the Central Gable (No. 7) onto the central base frame, as shown.

Secure in place using 3x40mm screws per side. Ensure to screw through the Central Gable framing into the first panel in the 'run' areas framing, as shown.

****Do NOT fix to the base framing until the Roof is secured****

6x40mm screws.

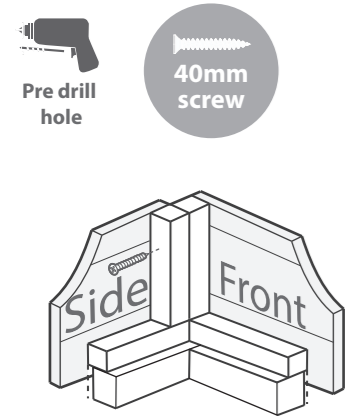

IMPORTANT: Pre-drill before fixing screws.

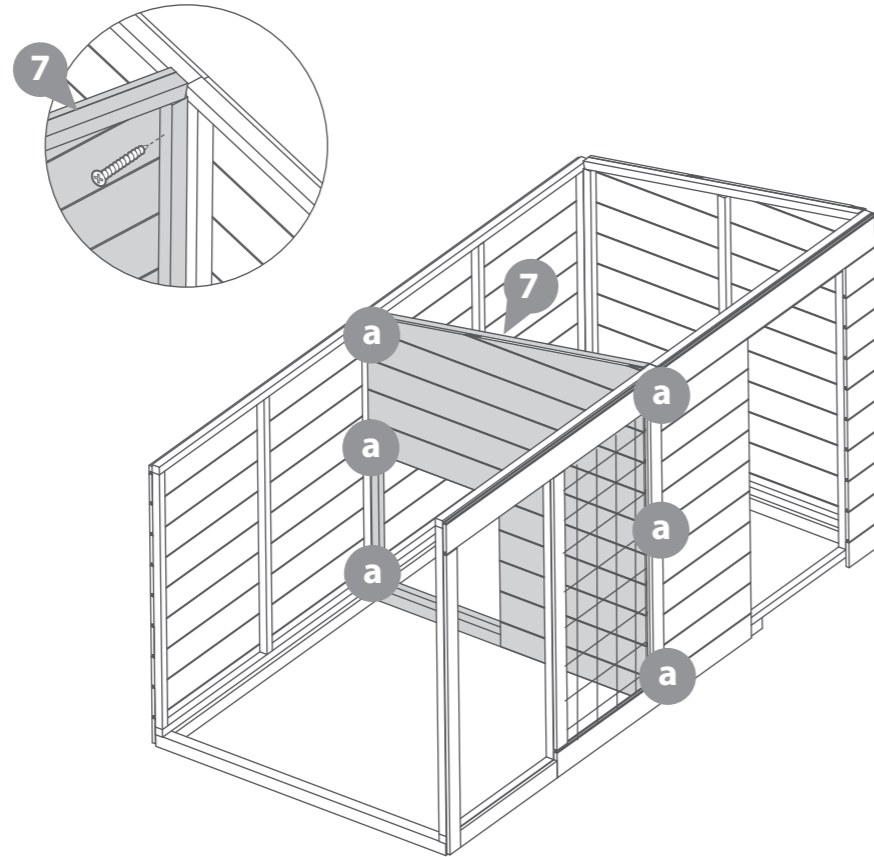

Step 7
Parts Needed - No. 6 QTY 1

Place the Left Gable (No. 6) onto the base framing, as shown.

Secure to the adjacent panels using 3x40mm screws per side.

****Do NOT fix to the base framing until the Roof is secured****

6x40mm screws.

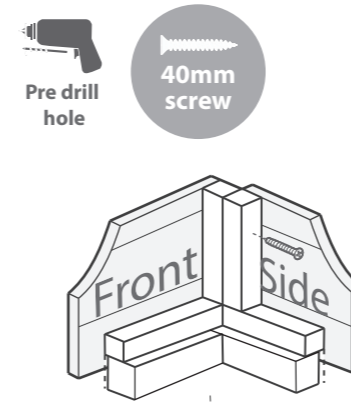

IMPORTANT: Pre-drill before fixing screws.

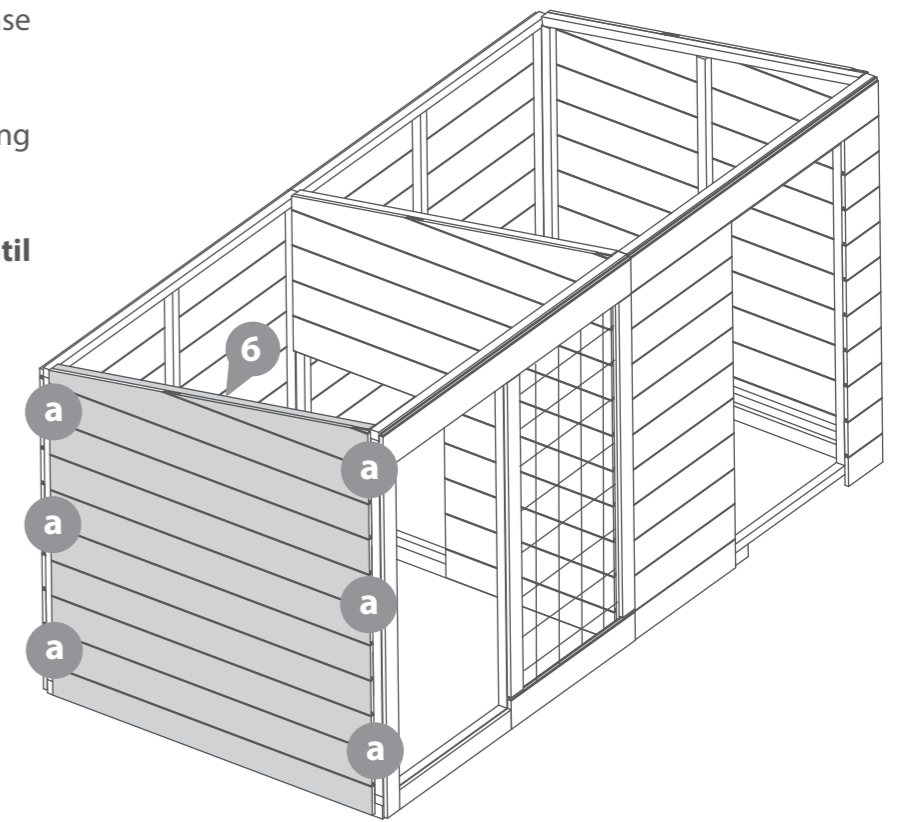

EXTENSION PACK B's:

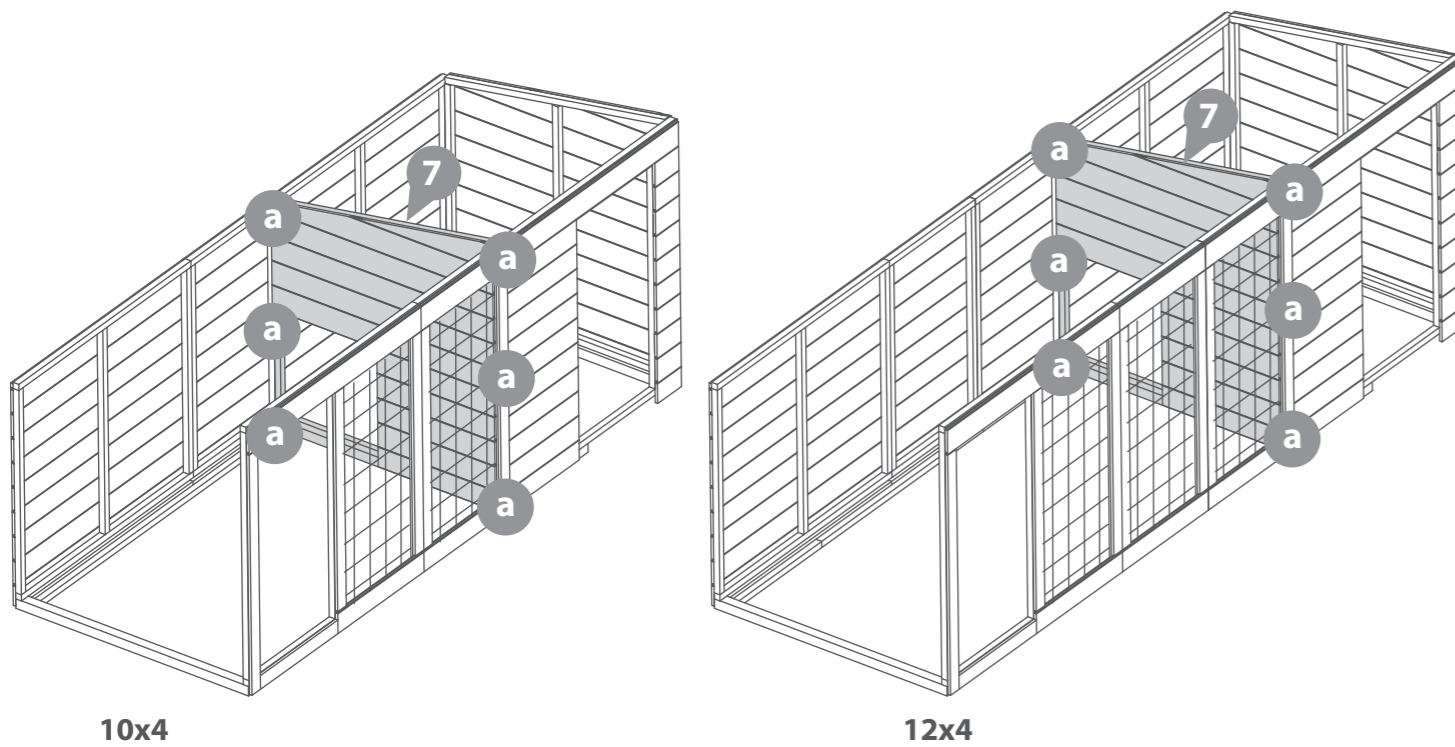

EXTENSION PACK B's:

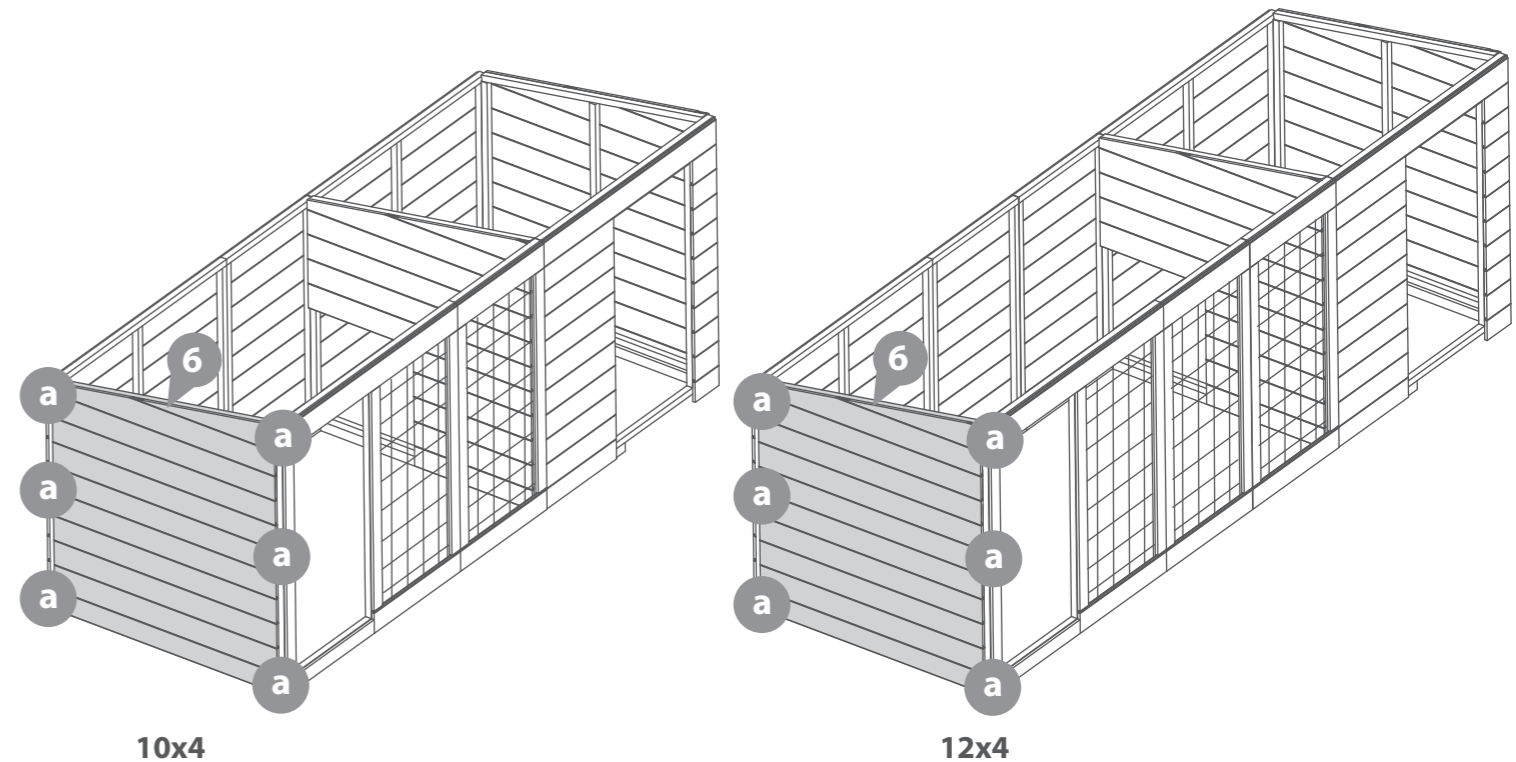

Step 8

Parts Needed - No. 17 QTY 1

Locate the Centre Framing (**No. 17**) to the framing side of the Centre Gable (**No. 3**). Ensure the framing is flush and level with that of the panel, as shown.

Secure in place using 3x40mm screws.

3x40mm screws.



IMPORTANT: Pre-drill before fixing screws.

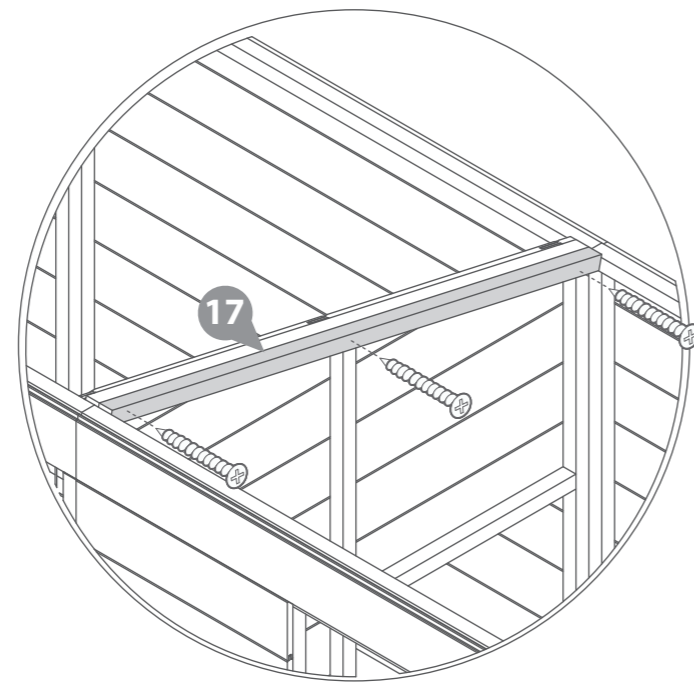

Step 9

Parts Needed - No. 9 QTY 2

Locate the Roof Panels (**No.9**) on top of the building as shown. Ensure the Panels sit on top of the Gables, are flush to the sides of the Gables and flush to the front of the building.

The Roofs will overhang at the back of the building.

Fix the panels together, internally using 4x40mm screws, screwing through the central framing. Ensure to stagger screws to avoid collision.

Secure the Roof Panels to the building using 60mm screws as shown.

**4x40mm screws.
26x60mm screws**

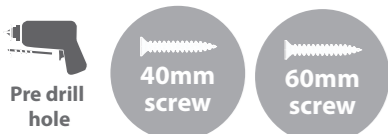

IMPORTANT: Pre-drill before fixing screws.

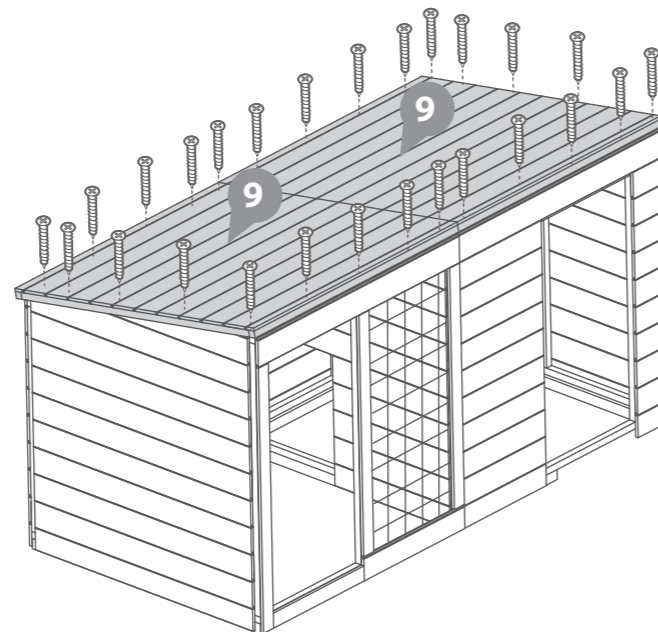

Internal view

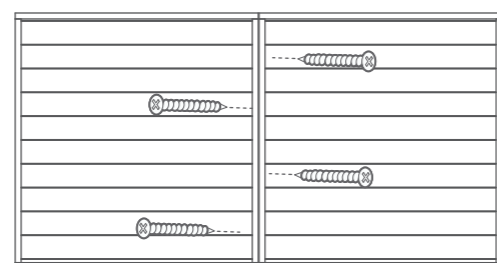

Step 9a - EXTENSION PACK B's.

10x4

**Parts Needed - No. 9 QTY 2
- No. 24 QTY 1**

Locate the Roof Panels (**No.9 & 24**) on top of the building as shown. Ensure the Panels sit on top of the Gables, are flush to the sides of the Gables and flush to the front of the building.

The Roofs will overhang at the back of the building.

Fix the panels together, internally using 4x40mm screws per join, screwing through the central framing. Ensure to stagger screws to avoid collision.

Secure the Roof Panels to the building using 60mm screws as shown.

**10x4:
8x40mm screws.
32x60mm screws.**

**12x4:
50x40mm screws.
38x60mm screws.**



IMPORTANT: Pre-drill before fixing screws.

12x4

**Parts Needed - No. 9 QTY 2
- No. 24 QTY 2**

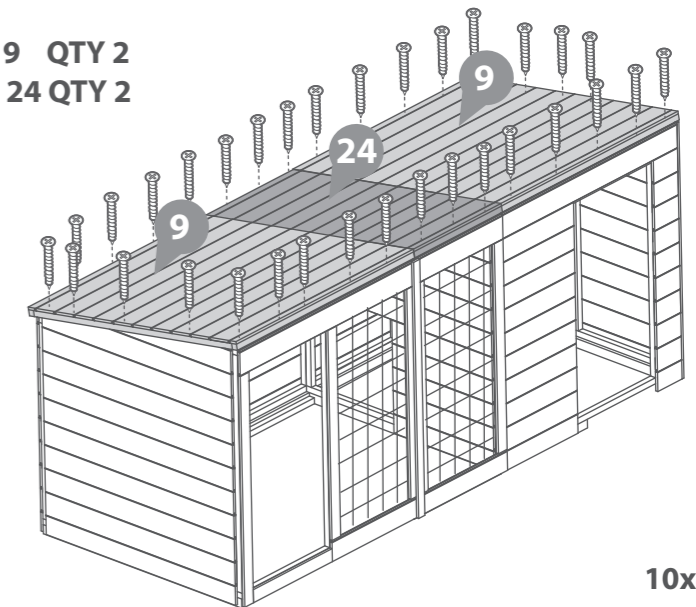

Internal view

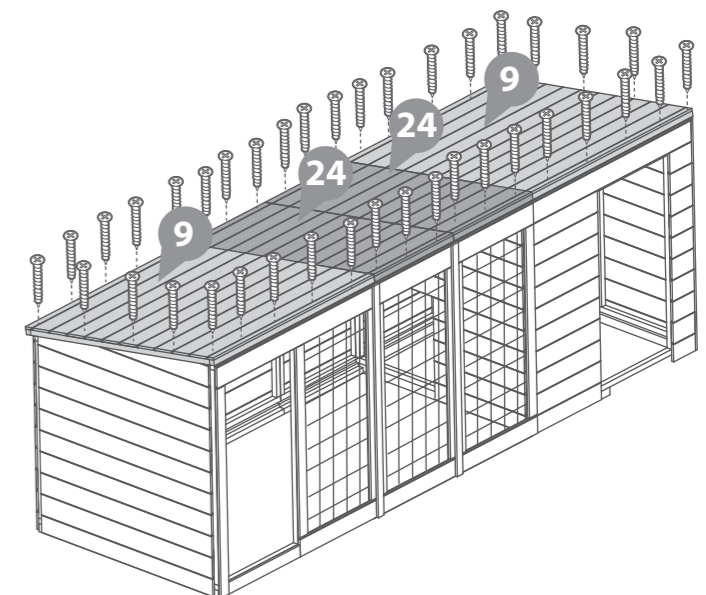
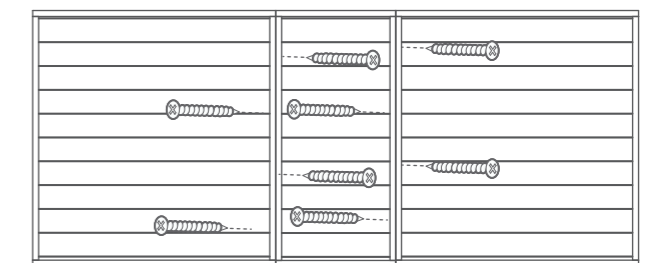

Internal view

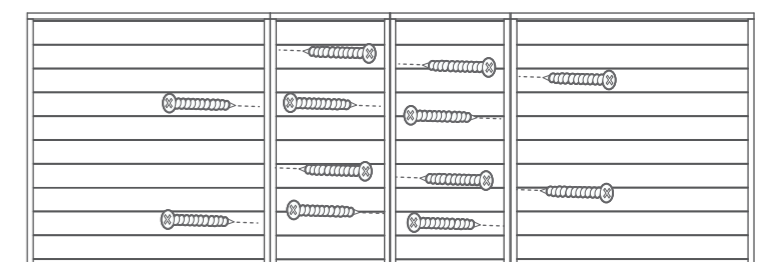

Step 10

Once the Roof Panels have been secured, fix the building to the base frame by screwing through the panels framing into the base frame using 50mm screws.

16x50mm screws.

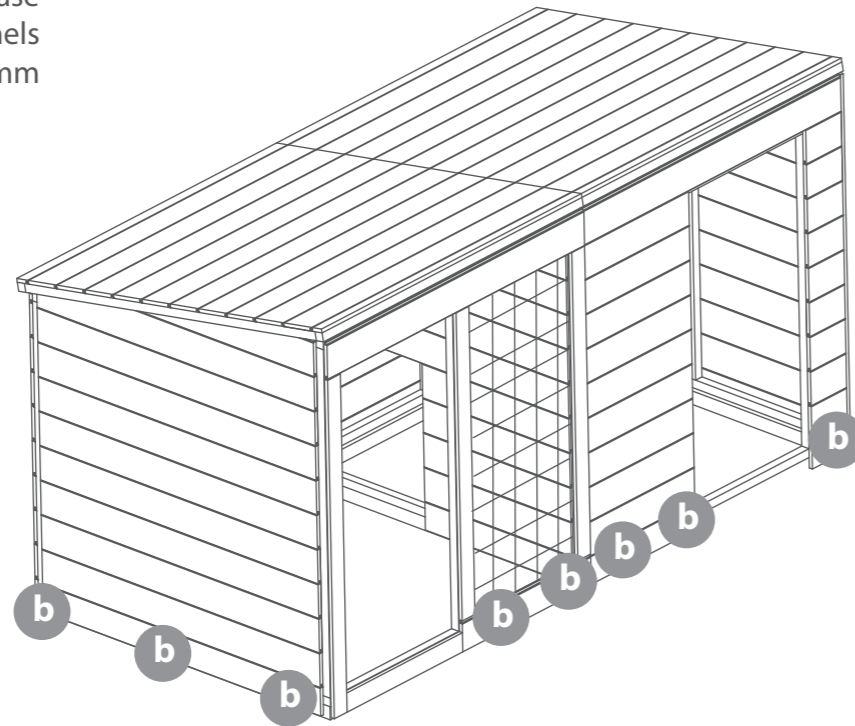
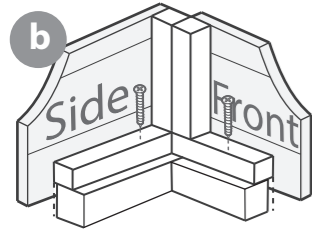
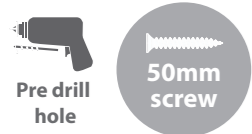

IMPORTANT: Pre-drill before fixing screws.

EXTENSION PACK B's:

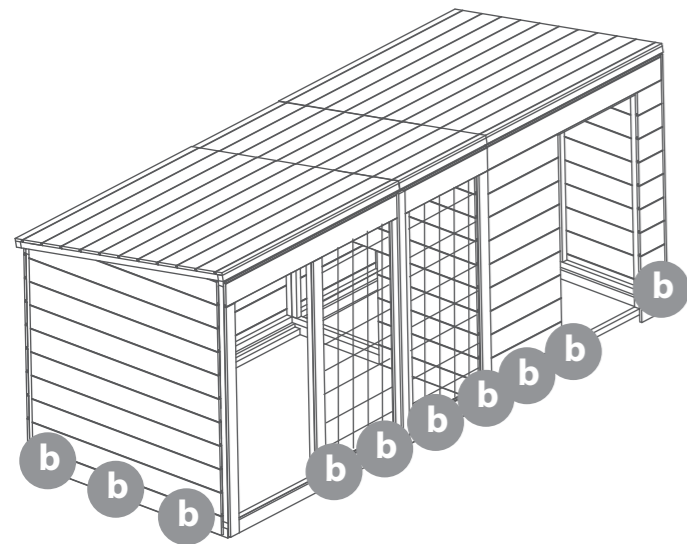

**10x4
20x50mm screws.**

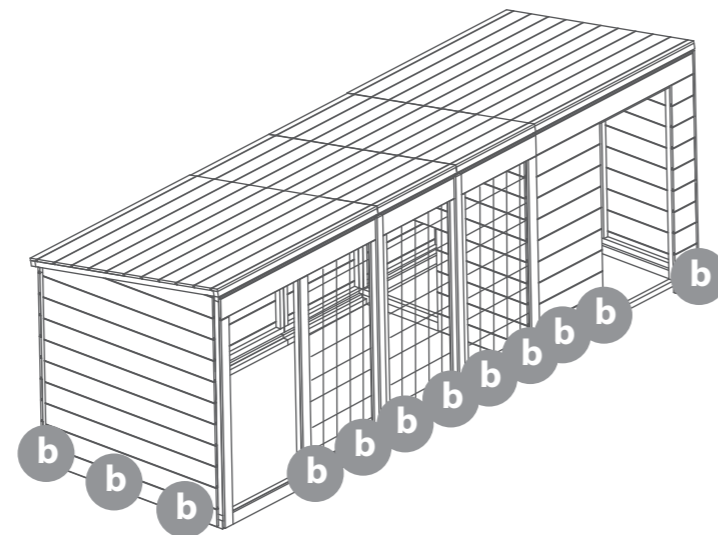

**12x4
24x50mm screws.**

Step 11

Parts Needed - No. 21 QTY 1

Cut the Felt (**No.21**) into two sheets measuring:
2400mm (L) X 1000mm(W)

Lay the sheets onto the building in the order shown in the illustration, ensure there is 50mm overhang on each side of the building and the sheets overlap by 100mm.

Secure the felt in place using felt tacks spaced at 100mm.

65 x Felt Tacks.

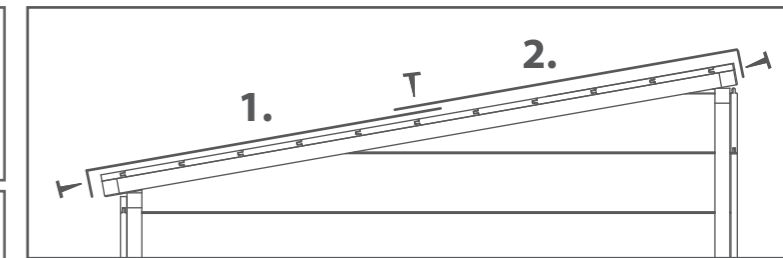
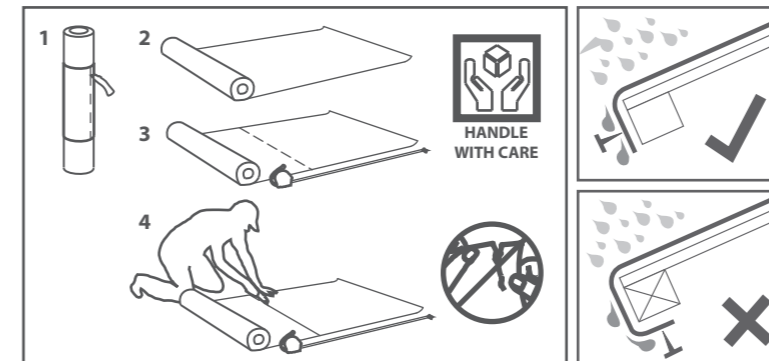
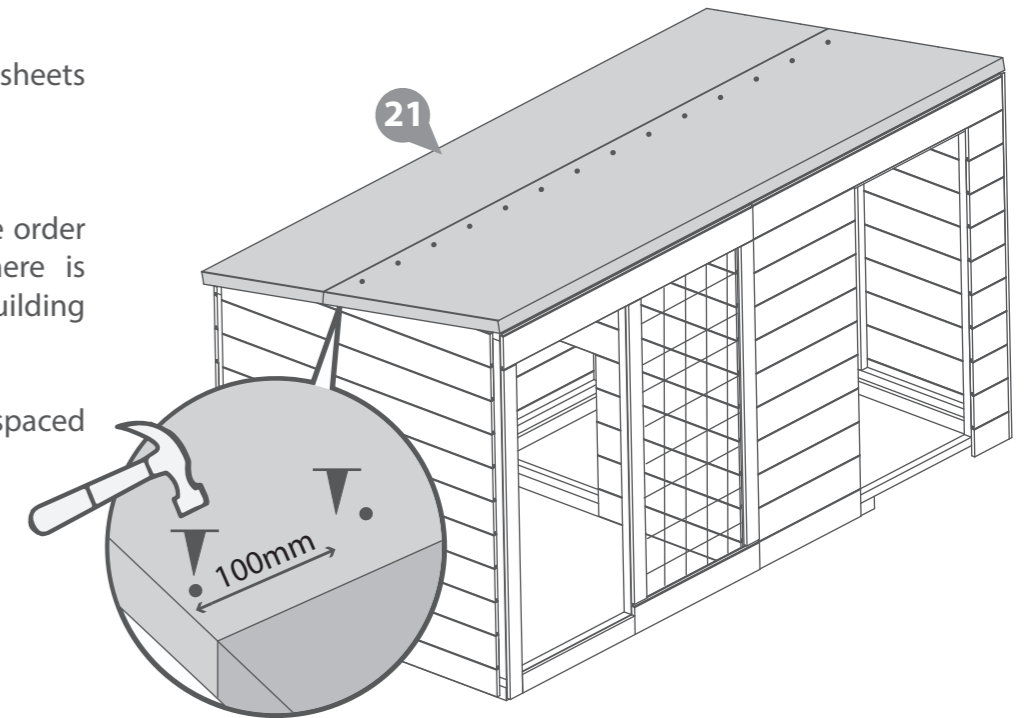

EXTENSION PACK B's:

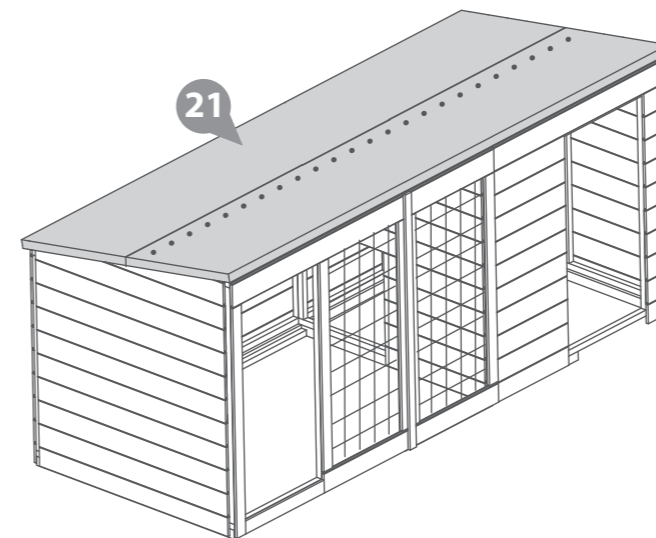

**10x4
2950mm (L) X 1000mm(W)
85 x Felt Tacks**

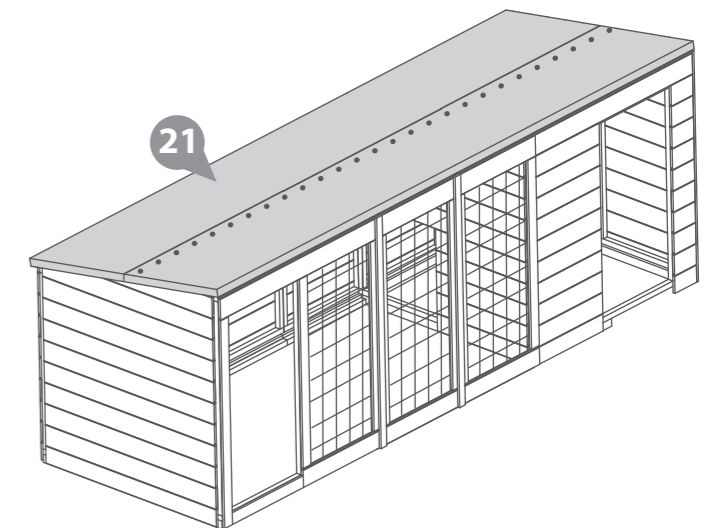

**12x4
3510mm (L) X 1000mm(W)
105 x Felt Tacks**

Step 12
Parts Needed - No. 2 QTY 1
- No. 19 QTY 3

Locate the Kennel Door (No. 2) into the Door opening in the Door Panel (No. 1), ensuring there is equal spacing on each side.

Secure three T-hinges (No. 19) to the Door and Door Panel using 7x30mm screws per hinge.

****8x4 building shown for illustrative purposes but the process is the same for the extension packs.****

21x30mm screws

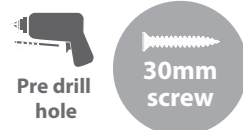

Step 13
Parts Needed - No. 4 QTY 1
- No. 19 QTY 3

Locate the Mesh Door (No. 4) into the Door opening in the Mesh Door Panel (No. 3), ensuring there is equal spacing on each side.

Secure three T-hinges (No. 19) to the Door and Door Panel using 7x30mm screws per hinge.

****8x4 building shown for illustrative purposes but the process is the same for the extension packs.****

21x30mm screws

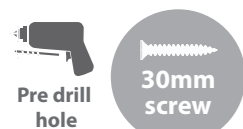

IMPORTANT: Pre-drill before fixing screws.

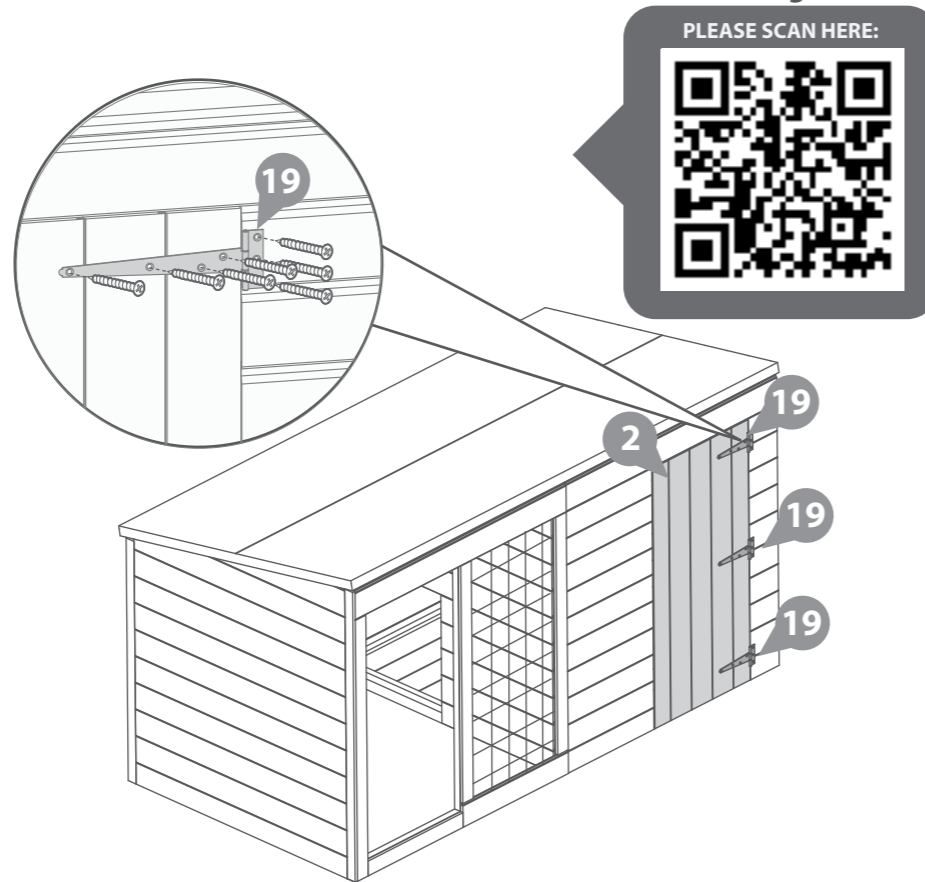

IMPORTANT: Pre-drill before fixing screws.

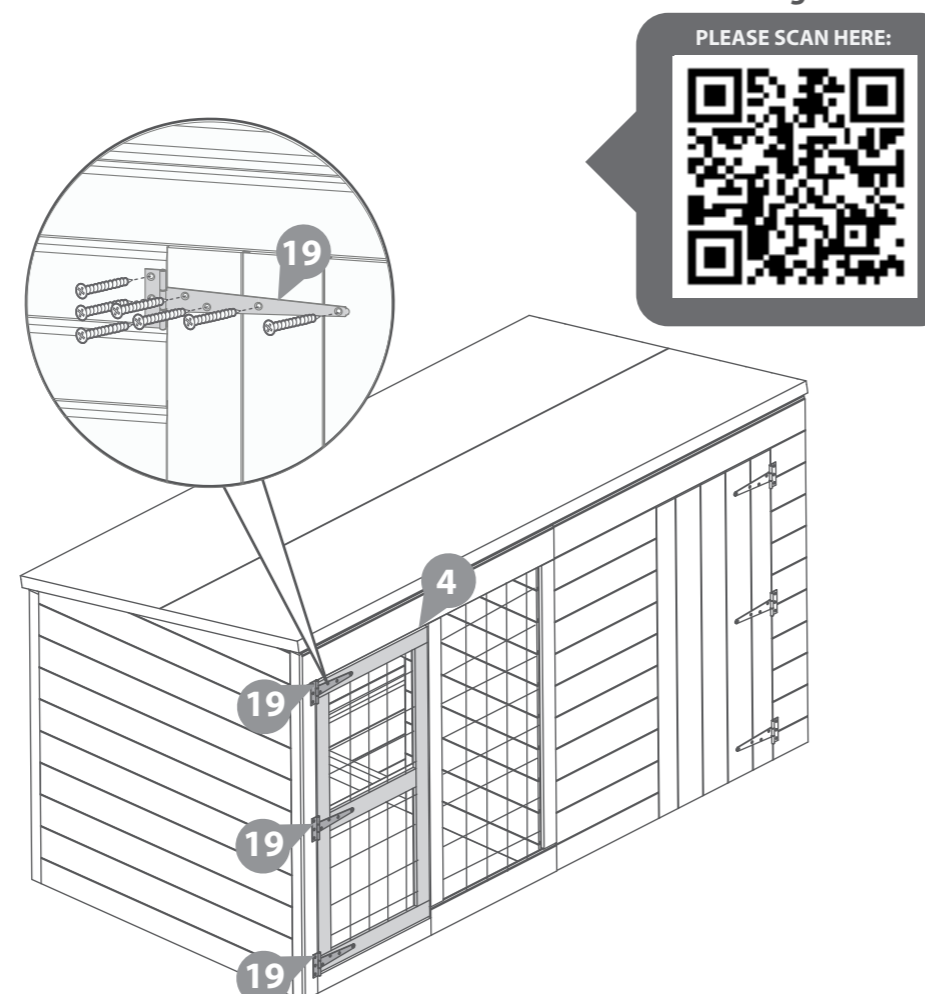

Step 14
Parts Needed - No. 18 QTY 2
- No. 20 QTY 4

a Locate a Pad Bolt (No. 18) onto each door. Ensuring to align it with the central Door framing.

Use 8x20mm screws to attach the Pad Bolt to the Doors and 4x30mm screws to attach the Pad Bolt catch to the building.

b Attach a Turn button (No. 20) to the top and bottom of each door. Fix in place using 1x20mm screw per Turn Button.

****8x4 building shown for illustrative purposes but the process is the same for the extension packs.****

20x20mm screws
 8x30mm screws



IMPORTANT: Pre-drill before fixing screws.

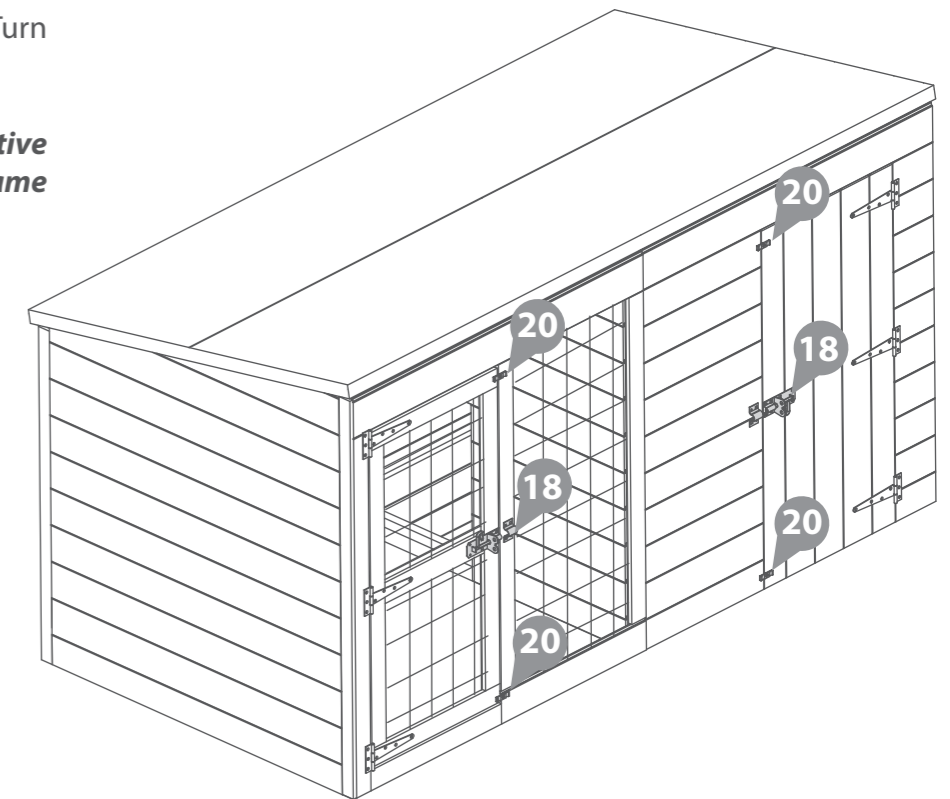
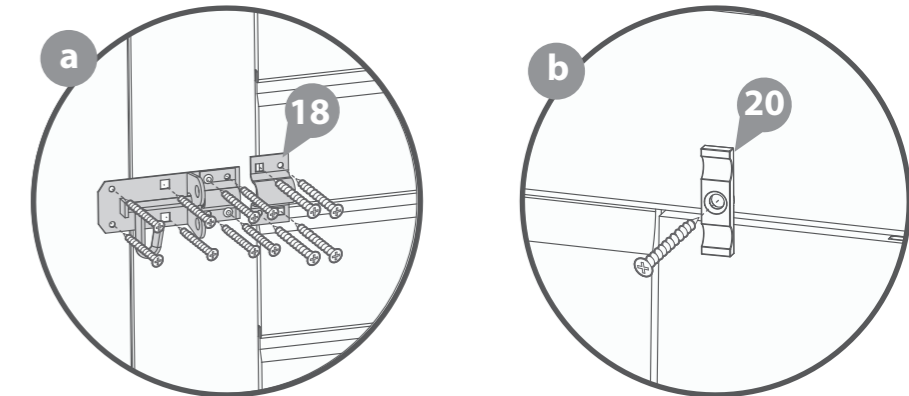

Step 15
Parts Needed - No. 12 QTY 6

Locate the Cover trims (No. 12) to the corners and faces of the building where the panels join, as shown.

Secure in place using 3x30mm screws per trim.

The rear Cover trims will need to be cut down to fit.

18x30mm screws.

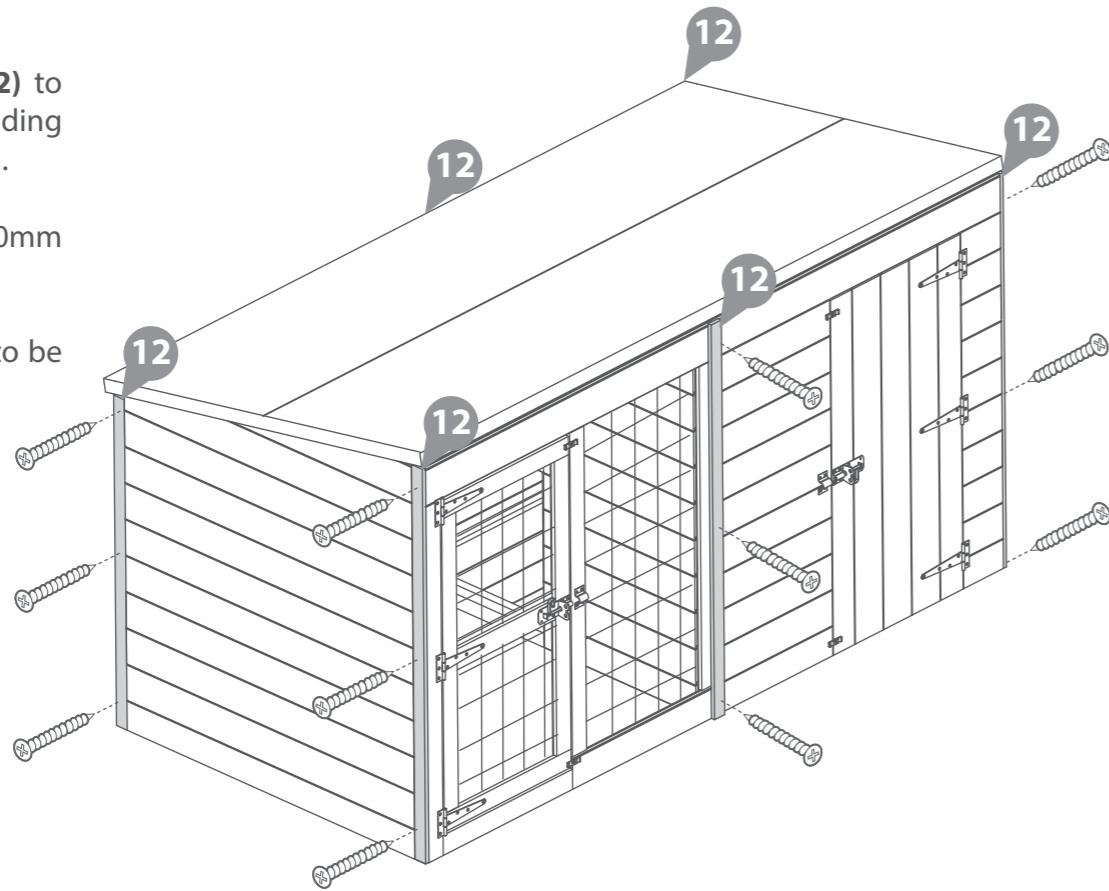
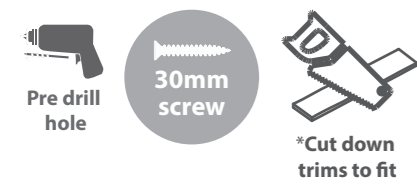

IMPORTANT: Pre-drill before fixing screws.

Step 15a - EXTENSION PACK B'S.

10x4
Parts Needed - No. 12 QTY 6
- No. 25 QTY 2

12x4
Parts Needed - No. 12 QTY 6
- No. 25 QTY 4

Locate the Cover trims (No. 12 & 25) to the corners and faces of the building where the panels join, as shown.

Secure in place using 3x30mm screws per trim.

The rear Cover trims will need to be cut down to fit.

10x4
24x30mm screws.

12x4
30x30mmscrews

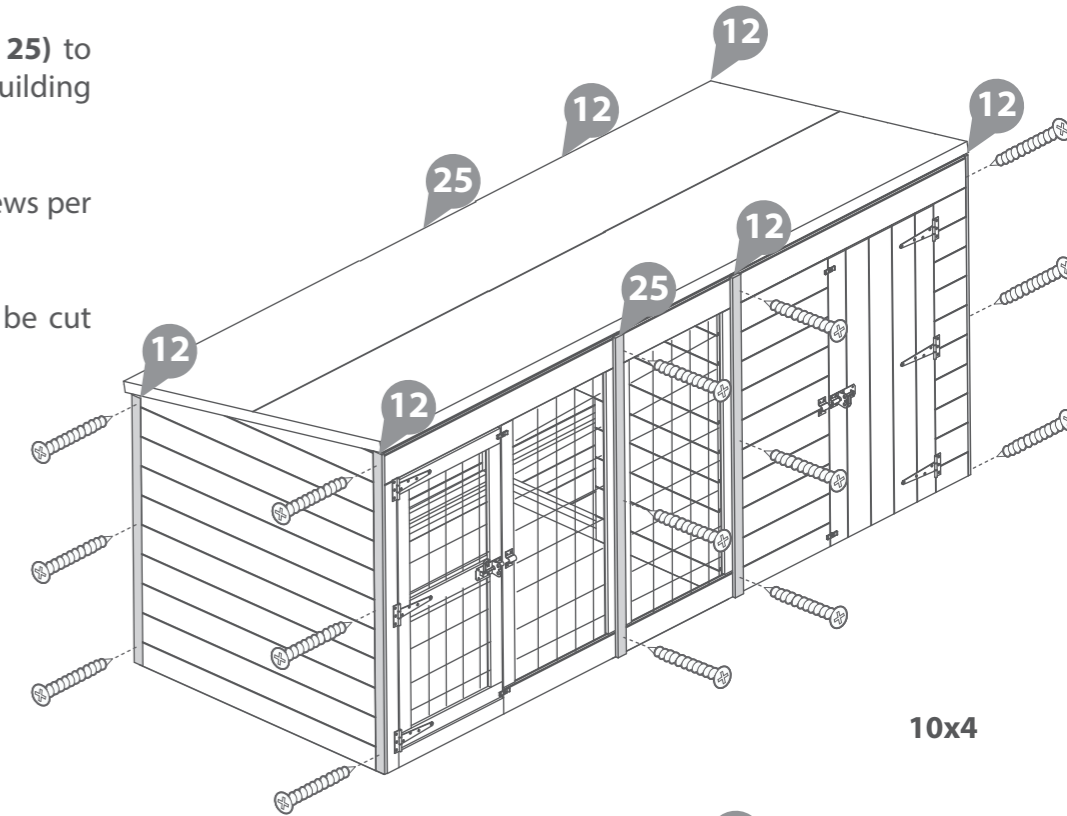
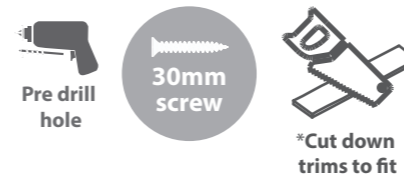

10x4

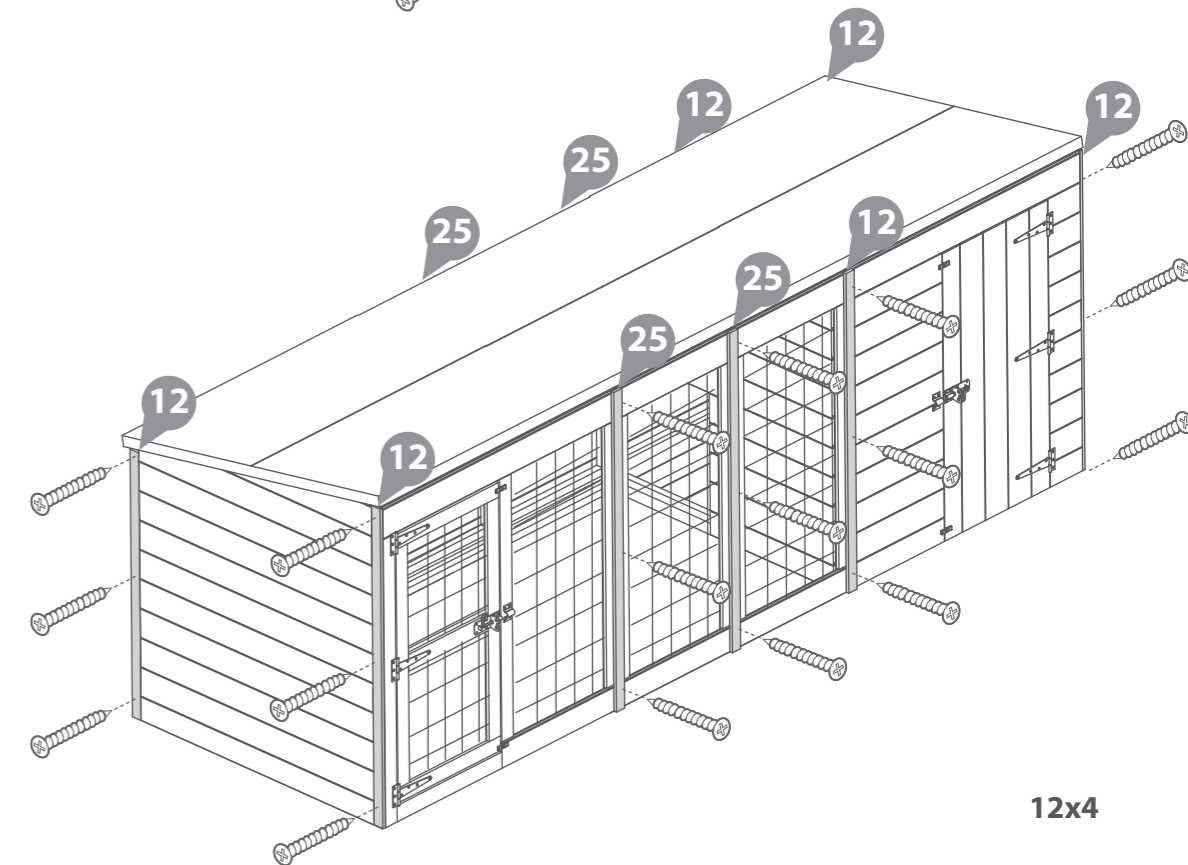

12x4

Step 16
Parts Needed - No. 11 QTY 4

Locate the Fascias (No. 11) to the front and sides of the building, ensuring they are flush to the top of the building and the ends.

Secure in place using 3x30mm screws per Fascia.

Some Fascias will need to be cut down to fit.

12x30mm screws.

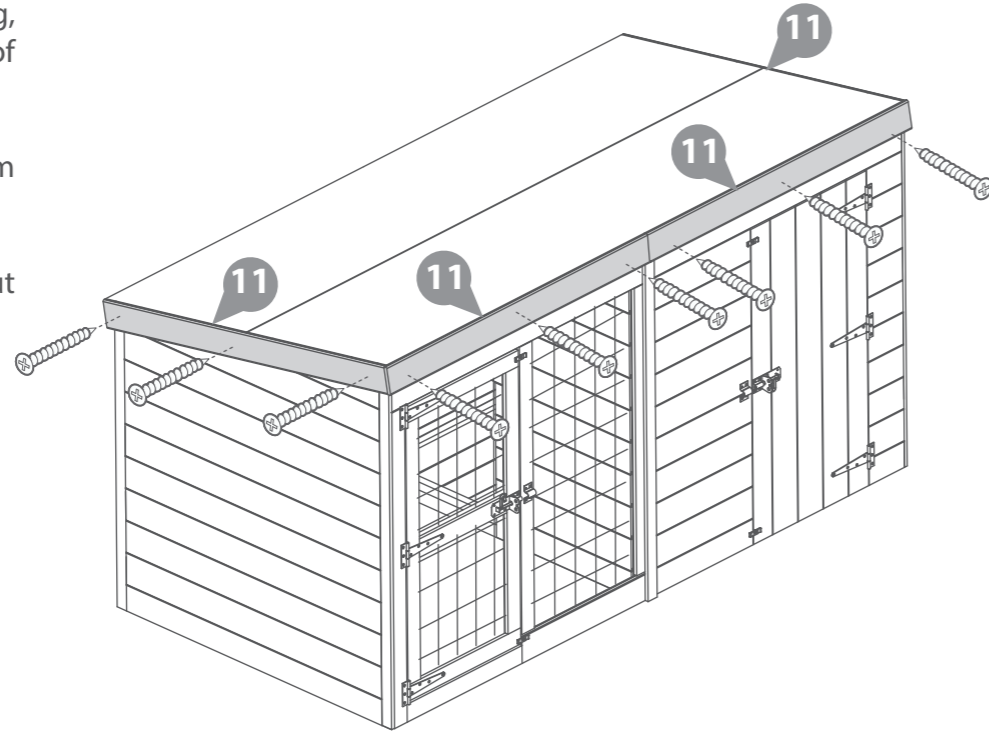
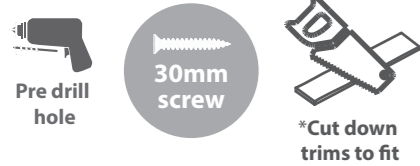

IMPORTANT: Pre-drill before fixing screws.

Step 16a - EXTENSION PACK B's.

10 x 4
Parts Needed - No. 11 QTY 4
- No. 28 QTY 1

12 x 4
Parts Needed - No. 11 QTY 4
- No. 28 QTY 2

Locate the Fascias (No. 11 & 28) to the front and sides of the building, ensuring they are flush to the top of the building and the ends.

Secure in place using 3x30mm screws per Fascia (No.11) and 2x30mm screws per add on Fascia (No. 28).

Some Fascias will need to be cut down to fit.

10x4
14x30mm screws.

12x4
16x30mm screws.

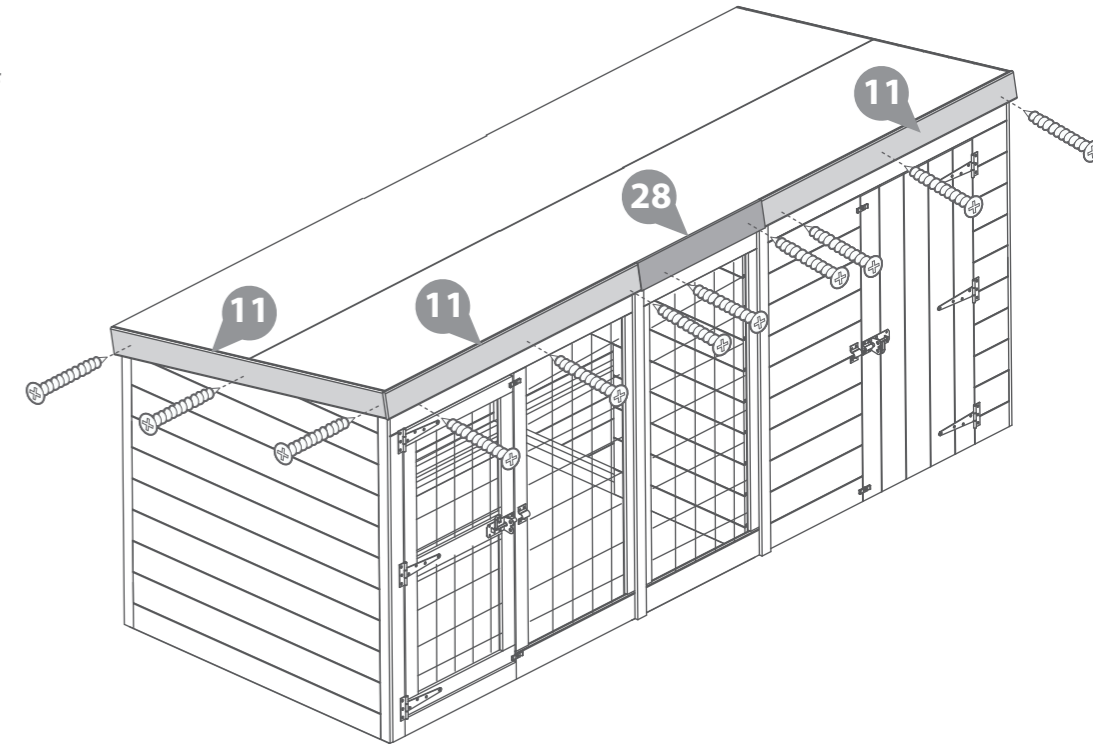
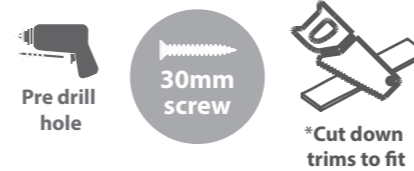

IMPORTANT: Pre-drill before fixing screws.

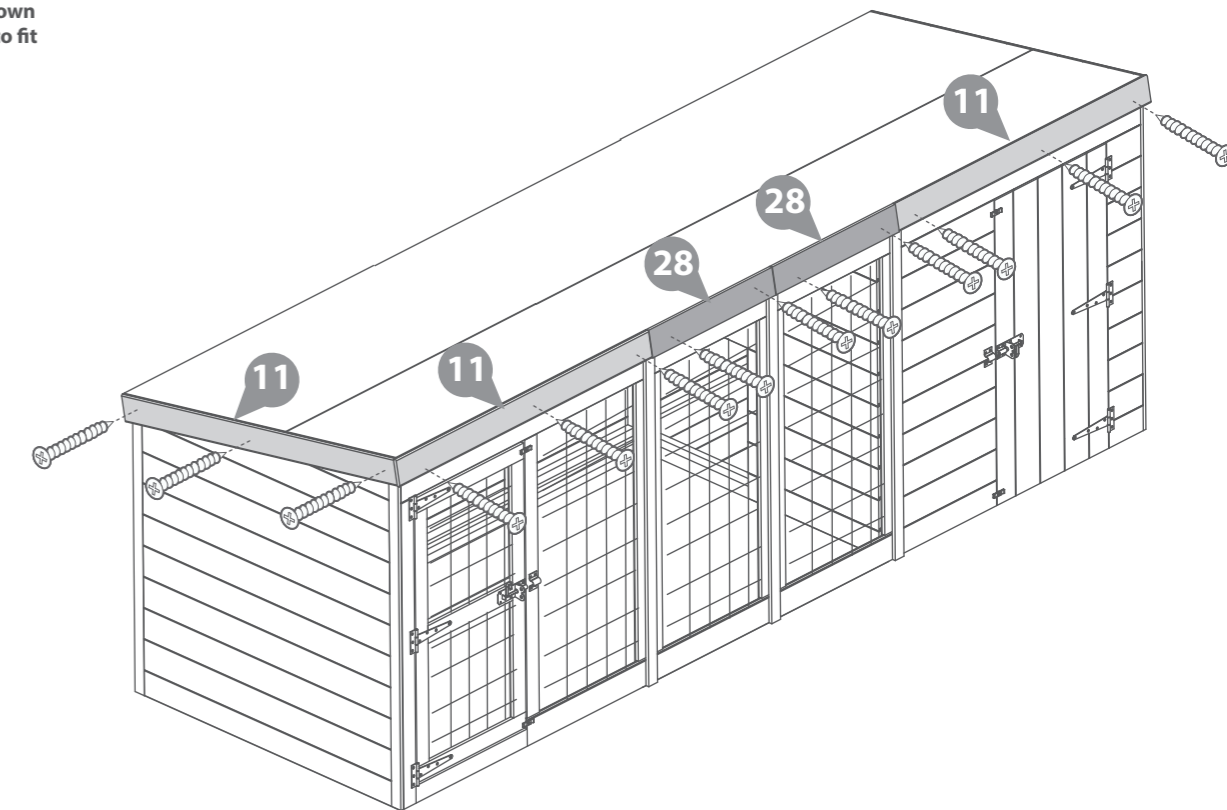

Step 17

Place the Floor Panels (**No.10**) into the kennel area as shown. Ensure they sit on the base framing and are flush and level.

These panels are removable so do not need securing in position.

***For ease of use, drill a finger sized hole in one panel.**

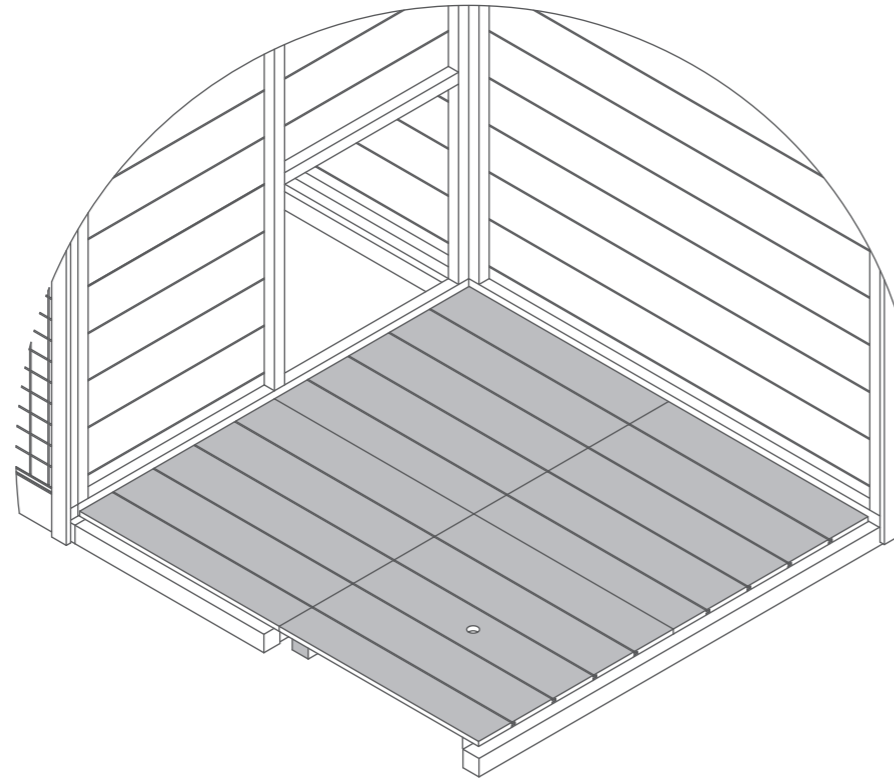

LEAVE US A REVIEW...



Want to share your experience with us?
Leave us a review on Feefo, TrustPilot or Google.

Your reviews help other people find and trust our business, as well as helping to play an important role in our growth and improvement!

TREATING YOUR GARDEN BUILDING

Preservation of wood that's outdoors is vital. A little early care will help protect your garden building, improve its appearance and ensure maximum longevity. Insects, moisture, salt, and changing weather can have dramatic effects on the stability and appearance of your garden building. Once your building is installed, you've checked it over and you're happy with it, you can take a few basic precautions to prepare it for the elements. Treating your garden building helps prevent decay and, by repelling water, discourages the growth of moulds and fungi that could jeopardise the structural integrity of the wood.

Dip Treated buildings - Require a preservative treatment to protect against rot and decay and a waterproof treatment to prevent water ingress
Pressure Treated buildings - Require a waterproof treatment to prevent water ingress
Log Cabins/Insulated Garden Rooms - Are supplied untreated and require a preservative and waterproofing treatment.



ANY QUESTIONS?
Scan the QR code to contact us via our customer portal.

To apply a preservative and water proofing treatment (pressure treated products do not require a preserver), follow the manufacturer's instructions but in principle, stick to the following steps:

- ✓ Wear latex or rubber gloves, eye protection and (if spraying) a mask.
- ✓ Prepare the wood, by sanding down any ridges or inconsistencies in the wood, smoothing out knots and end-cuts.
- ✓ Choose a dry day to treat your garden building. If you're spraying rather than brushing paint on, avoid a windy day.
- ✓ Be sure you can safely reach all the sections you need to paint - and if you need a ladder, make sure it's safely positioned before climbing. Lay dust sheets around to avoid paint splatters on your base or surrounding plants.

- ✓ Tape around windowpanes to avoid smears when you're painting the frames.
- ✓ Keep pets and small children out of the way. The last thing you want is to have fur on your garden building paint, or little painted footprints all over your garden and home.
- ✓ Fill any gaps in the building's body with caulk or wood filler to prevent water and draughts getting in. Silicone based caulk is flexible and will move with the timber when temperature and humidity change. Allow to dry completely before treating. A handy tip for finding gaps is to go into your garden building and look for light leaking through joints and frames. If light gets in, then so will water.
- ✓ Liberally apply at least two coats of the treatment products with a brush or spray, taking care to allow the first coat to completely dry before applying the second.
- ✓ Make sure the solution permeates the whole of the surface area, especially around natural cracks, end cuts and nail/screw holes.



APPLY WOOD TREATMENT
IMMEDIATELY
AFTER ASSEMBLY

PLEASE SCAN HERE TO
SEE TREATMENT VIDEO:



1 Perimeter

Check around the perimeter of your product to ensure there are not trees or plants that are in contact with or overhanging the building. This can affect airflow and overhanging trees, or branches can damage the roof, it is advised to keep plants at a distance.

2 Repair

Inspect the interior and exterior of the product to look for splits, cracks, and holes. Although this is a natural occurrence it can be prevented. A wood filler can be used to close the splits, cracks, and holes.

3 Roof

Check your roof regularly for tears, splits, damaged wood and fallen debris. If you notice any of this immediate repair is critical.

4 Doors & Windows

Expansion and contraction can cause doors and windows to stick or become difficult to open. Small adjustments to the hinge position can be made to the doors and windows to allow free movement.

5 Oil

Hinges can seize up over time, apply lubricant to the hinges and locks annually.

6 Screws & Bolts

It is advised to check all screws and bolts and tighten any loose you might find. For log cabins specifically the storm braces will require loosening. During humidity and temperature changes (seasons) to allow expansion and contraction to prevent gaping, twisting, popping, and warping.

7 Wash

At least once a year, give the outside of your building a good wash, to remove cobwebs, leaves, or any other dirt that may accumulate on the exterior.

8 Airing

Airing your product regularly prevents the build up of condensation which can cause the timber to rot and mould. Condensation can build up over time or daily, it is caused by a rise and fall in temperature. Leaving doors and windows open regularly can help combat the natural moisture build up.

9 Clean & Tidy

It is good practice to clean the inside and outside of your product regularly. Clear out the contents, sweep the floor, remove dirt and cobwebs. Check for areas of damp and investigate the cause to remove and prevent future occurrences. Check the ground around your product for build up of debris such as leaves, remove and ensure there is clear ventilation underneath the floor.

Additional Playhouse Maintenance:

It is recommended that the following checks and maintenance are carried out at the beginning of each season as well as at regular intervals during the usage season.

- Check all nuts /bolts/ screws for tightness and tighten when required.
- Check for movement / opening of wood giving rise to protrusion of nail heads and tips.
- Check hinges.
- Replace defective parts in accordance with the manufacturers instructions.
- Check any crossbeams, suspensions and anchors.
- If a swing is included; check the swing seat, chains and ropes.

IF THESE CHECKS ARE NOT CARRIED OUT THE ACTIVITY TOY COULD BECOME A HAZARD

All our garden buildings have been designed and manufactured with care and attention to be the perfect addition to your outdoor space. To ensure you do get the best out of your new garden building and to increase the longevity we advise that you follow the product instructions and our manufacturer's recommendations as detailed below. Thank you for choosing a Mercia Garden product!

1 Choosing the most suitable location for your garden building...

A minimum of 60cm should be left around the perimeter of your garden building to allow access for maintenance, annual treatment and to allow air flow around the building.

Where possible you should avoid placing your garden building underneath large trees to prevent the tree causing damage to the building.

2 Preparing the base for your garden building...

All our buildings must be built on a firm, level base to ensure the longevity of the building and prevent the wood from distorting. We recommend either concrete, concrete slabs or a wooden base, such as our 'Portabase'.

The base should be slightly smaller than the external measurement of the building, i.e. the cladding should overlap the base, creating a run off for water and preventing water from pooling underneath the building.

We also recommend that the floor of the garden building is a minimum of 25mm above the surrounding ground level to avoid flooding.

3 After installation...

Once your garden building has been installed, it will need to be treated within 14 days (weather permitting) and annually to prevent the timber from deteriorating and to waterproof it. This is required to maintain the anti-rot guarantee.

Dip Treated buildings - Require a preservative treatment to protect against rot and decay and a waterproof treatment to prevent water ingress.

Pressure Treated buildings - Require a waterproof treatment to prevent water ingress.

Log Cabins/Insulated Garden Rooms - Are supplied untreated and require a preservative and waterproofing treatment.

We also recommend using a silicon sealant on the inside and outside of the windows as soon as possible after assembly and treatment to fully seal the windows.

Roofing felt/covering should be checked annually and replaced or fixed accordingly.

4 General maintenance and wood characteristics

As wood is a natural material it may be affected by the following:

Shrinkage and warping - The timber used in the construction of your garden building will have retained some of its natural moisture content. The moisture content of the timber will vary, depending upon prevailing environmental conditions, which will result in the components either naturally expanding or contracting. As the components dry out, shrinkage may occur. A good waterproofing treatment from the start is the best protection to minimise the effect of moisture loss/intake.

In extended periods of very warm weather getting some moisture to the building will help the overall balance. You can do this by spraying it down lightly with a garden hose. In contrast, after snow fall try to remove the snow as best as possible from the roof to prevent moisture intake and to remove the extra weight.

Top tip - using a garden brush will help you to reach the highest part of the building to remove snow and any debris left from bad weather.

Damp and mould - During the winter months, cold and damp conditions can result in an increased amount of moisture within your garden building, especially when used infrequently. Condensation can form on the timber and other items stored within your garden building. If left this moisture is likely to cause mould and mildew.

To prevent the build-up of moisture, we recommend leaving the door or windows of your building open from time to time, to allow the fresh air to circulate. We also advise against storing wet or damp items in your garden building as this will also increase the level of moisture in the building. If mould or mildew does start to form within your building we recommend using an anti-mould cleaner to remove it and to prevent it spreading, which if left untreated could permanently damage your garden building.

Splits, cracks and knots - You may notice small splits and cracks in some components or holes may appear where knots shrink and fall out. This will not affect the structure of your Garden building however, if you wish to fill them this can be easily done using any good quality wood filler.

Sap - is naturally occurring in wood and may appear in some boards of your garden building. If you wish to remove the sap, we advise waiting until it is dry and then using a sharp knife to carefully remove it. If the removal of the sap causes a hole in the timber, we recommend using a good quality wood filler to fill it.

For more handy hints and tips on how to care and maintain your garden building please refer to the MGP Customer Portal at www.mgplogistics.co.uk

Any further questions?

Contact our
Customer Service Team via the MGP
Customer Portal at:
www.mgplogistics.co.uk

1 Manufacturer's Warranty

All Mercia Garden Products are supplied with a 1 year warranty on all parts against manufacturing defects.

This warranty does not cover movement, warping or splitting of timber products over time.

This warranty will be voided if any of the following occur:

1. The building has been customised or modified/adapted in any way.
2. The person claiming is not the original purchaser of the building.
3. Any damage has been caused by or as a result of misuse.
4. The building has not been maintained and cared for in accordance to our advisories and manufacturer's recommendations.
5. The building has not been treated annually or as per the manufacturer's recommendations, please ensure receipts are kept to validate this claim.
6. The building has not been erected, fitted or installed as per the supplier instructions.
7. The building has not been erected on a suitable sized firm flat, solid level concrete/slab base or placed on pressure treated bearers.
8. The building is or has been placed with 2 feet (600mm) of any obstructions (walls, trees, plants, fences etc.) which can allow moisture to penetrate the timber.
9. The roofing felt has been incorrectly fitted or damaged, allowing water ingress, or has not been properly maintained.
10. Any windows and joints have not been sealed, inside and out, with silicone or other watertight sealant.
11. Any timber has been cut, pierced or drilled without subsequent application of approved cut-end treatment.

2 Anti-rot Guarantee

Mercia Garden Products offer a 10 year anti-rot guarantee on all dip treated (a preparatory treatment) and 15 years on all pressure treated products. This guarantee covers solid timber against rot, decay, blue stain and insect attacks.

To validate the guarantee, the building must be treated (as detailed within manufacturer's recommendations) within 14 days (weather permitting) of assembly and annually thereafter.

This guarantee does not cover movement, warping or splitting of timber products over time.

This guarantee will be voided if any of the following occur:

1. The building has been customised or modified/adapted in any way.
2. The person claiming is not the original purchaser of the building.
3. Any damage is caused by or as a result of misuse.
4. The building has not been maintained and cared for in accordance to our advisories and manufacturer's recommendations.
5. The building has not been treated annually or as per the manufacturer's recommendations, please ensure receipts are kept to validate this claim.
6. The building has not been erected, fitted or installed as per the supplier instructions.
7. The building has not been erected on a suitable sized firm flat, solid level concrete/slab base or placed on pressure treated bearers.
8. The building is or has been placed with 600mm of any obstructions (walls, trees, plants, fences etc.) which can allow moisture to penetrate the timber.
9. The roofing felt has been incorrectly fitted or damaged allowing water ingress, or has not been properly maintained.
10. Any windows and joints have not been sealed, inside and out, with silicone or other watertight sealant.
11. Any timber has been cut, pierced or drilled without subsequent application of approved cut-end treatment.



REGISTER FOR YOUR
ANTI-ROT
GUARANTEE TODAY

PLEASE SCAN HERE:

