

01DTSHPN0806SDFW-V1
8X6 SHIPLAP PENT SHED.



x2 All buildings should be erected by two adults



Winter = High Moisture = Expansion
 Summer = Low Moisture = Contraction



2mm Drill bit

For ease of assembly, you **MUST** pilot drill all screw holes and ensure all screw heads are countersunk.



CAUTION
 Every effort has been made during the manufacturing process to eliminate the prospect of splinters on rough surfaces of the timber. You are strongly advised to wear gloves when working with or handling rough sawn timber.



For ease of assembly, you will need a tape measure to check dimensions of components.



Screws & Nails

Measure overall length

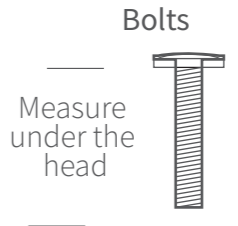

Bolts

Measure under the head

To identify the fixings required for each step use a measuring tape.

****Protim Aquatan T5 (621)****

Your building has been dip treated with Aquatan.

Aquatan is a water-based concentrate which is diluted with water, the building as been treated by the correct application of Aquatan solution and then allowed to dry.

Aquatan is a decorative finish to colour the wood, which is applied industrially to timber fence panels and garden buildings.

Aquatan undiluted contains: boric acid, sodium hydroxide 32% solution, aqueous mixture of sodium dioctyl sulphosuccinat and alcohols: 2, 4, 6-trichlorophenol.

BEFORE YOU START PLEASE READ INSTRUCTIONS CAREFULLY

- Check the pack and make sure you have all the items listed in the parts list provided.
- When you are ready to start, make sure you have the right tools at hand (not supplied - see the equipment list on next page).
- Ensure there is plenty of space and a clean dry area for assembly.
- Ensure you have enough time to build the product to ensure the building is water tight.

LOCATION FOR YOUR GARDEN BUILDING

A minimum of 600mm should be left around the perimeter of your garden building to allow access for maintenance, annual treatment and to allow air flow around the building.

Where possible you should avoid placing your garden building underneath large trees to prevent the tree causing damage to the building.

TIMBER

As with all natural materials, timber can be affected during various weather conditions. For the duration of heavy or extended periods of rain, swelling of the wood panels may occur. Warping of the wood may also occur during excessive dry spells due to an interior moisture loss. Unfortunately, these processes cannot be avoided but can be helped. It is suggested that the outdoor building is sprayed with water during extended periods of warm sunshine and sheltered as much as possible during rain or snow.

Once your garden building has been installed it will need to be treated within 14 days (weather permitting) and annually to prevent the timber from deteriorating and to waterproof it. This is required to maintain the anti-rot guarantee.

- Dip Treated buildings - Require a preservative treatment to protect against rot and decay and a waterproof treatment to prevent water ingress
- Pressure Treated buildings - Require a waterproof treatment to prevent water ingress
- Log Cabins/Insulated Garden Rooms - Are supplied untreated and require a preservative and waterproofing treatment.

BUILDING A BASE

When thinking about where the building and where the base is going to be constructed: Ensure that there will be access to all sides for maintenance work and annual treatment.

Ensure the base is level and is built on firm ground, to prevent distortion. Refer to diagrams for the base dimensions, The base should be slightly smaller than the external measurement of the building, i.e. The cladding should overlap the base, creating a run off for water. It is also recommended that the floor be at least 25mm above the surrounding ground level to avoid flooding.

TYPES OF BASE

- Concrete 75mm laid on top of 75mm hard-core.
- Slabs laid on 50mm of sharp sand.
- Wooden base.

Whilst all products manufactured are made to the highest standards of safety and in the case of children's products independently tested to EN71 level, we cannot accept responsibility for your safety whilst erecting or using this product.

REGISTER FOR YOUR ANTI-ROT GUARANTEE TODAY

PLEASE SCAN HERE:

In all instances for assistance with your product, please contact us via our customer portal: <https://www.mgplogistics.co.uk/>.

Mercia Garden Products Limited,
 Sutton On Trent,
 Newark,
 Nottinghamshire,
 NG23 6QN

TO DO LIST

- Find a suitable location to build *(see front cover for further information).*
- Build a base *(see front cover for further information).*
- Check the base is flat, level, clear of debris and has 60cm clearance on all sides.
- Check you have the required equipment.
- Check you have all the product items listed *(if you have missing or damaged parts please contact the customer services department, see front cover for contact details).*
- Install the product as per the step by step instructions within this pack.
- Prepare the product ready for treatment.
- Apply a preserving and a waterproofing treatment within 14 days *(weather permitting)* of installation *(pressure treated products do not require a preserver).*
- Register for your anti rot guarantee *(scan the QR below).*
- Tidy the build area and dispose of any remaining parts responsibly.
- Maintain your building *(see the manufacturers recommendations at the back of this pack).*

EQUIPMENT LIST

- Hammer
- Flat Head Screwdriver
- Drill
- Drill Bit Set
- Phillips and Slotted Bit Sets
- Tape Measure
- Hand Saw
- Spirit Level
- Ladders/Steps
- Stanley Knife/Cutting Tool
- Sand Paper
- Gloves
- Silicone (For Windows Only)
- Wood Filler (Optional)
- Timber Preservative Treatment *(not pressure treated products)*
- Timber Water Proofing Treatment
- Treatment Mixing Stick
- Paint Brush/Sprayer/Roller

NEED EXTRA SUPPORT

If you are unsure that your base preparation will be suitable, please contact us on 01636 821215 to discuss this further.

Alternatively, you can visit our website or MGP Logistics Online Portal for some further shededucation.

Website:

<https://www.merciagardenproducts.co.uk/sheducation>

MGP Logistics Online Portal:

<https://www.mgplogistics.co.uk/>

Here you will find plenty of useful information that'll help with most pre-installation and maintenance queries.

PLEASE SCAN HERE:



ANY QUESTIONS?

Scan the QR code to contact us via our customer portal.

NOTES

ACCESSING VIDEO GUIDES...

Some steps within this set of instructions come with an added video guide for your convenience. These can be accessed via the QR code and used to aid you in constructing that step. See below for how to use.

You can also find all the videos on our youtube channel:
<https://www.youtube.com/@merciagardenproducts8716/videos>

1. Find the QR code within the instruction step...

Step.....

Parts Needed- No. QTY 1
No. QTY 1
No. QTY 1



Within the instruction step, there will be an icon in the top right that has a QR code in. This is where the video can be accessed from.

Please note: not every step has a video guide.

2. Open camera app...

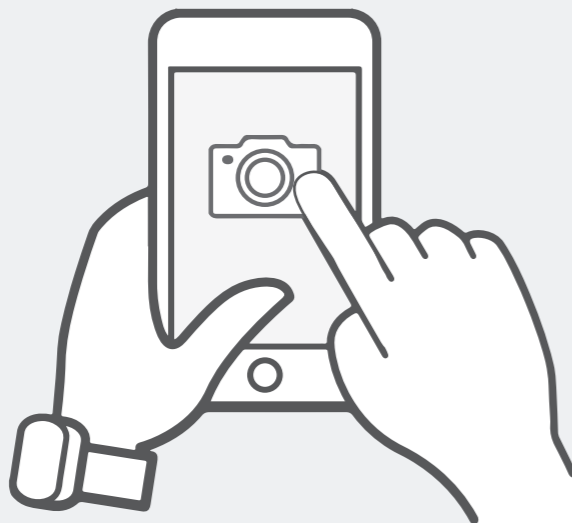

On your personal smart device (phone, tablet etc), open your camera app or QR code scanner app.

ACCESSING VIDEO GUIDES...

3. Scan QR code...



To scan the QR code, hold the camera over the QR code so that it can be seen on the screen. Once the QR code has been registered, follow the prompts on your device to open the video. (This will vary depending on your device.)

Please note: Ensure to use the back camera of your smart device as this will scan the QR code more accurately.

4. Watch the video...



The video guide will now be displayed on your smart device.

Disclaimer: The garden building constructed in the video guides may be constructed differently to your building. Please ensure to read your instructions carefully to avoid error.

Please retain product label and instructions for future reference

Before assembly
please make sure you have a
suitable base ready to erect your
building



MADE IN GREAT BRITAIN

Overall Dimensions: Width = 2408mm
Depth = 1875mm
Height = 2085mm

Base Dimensions: Width = 2350mm
Depth = 1753mm

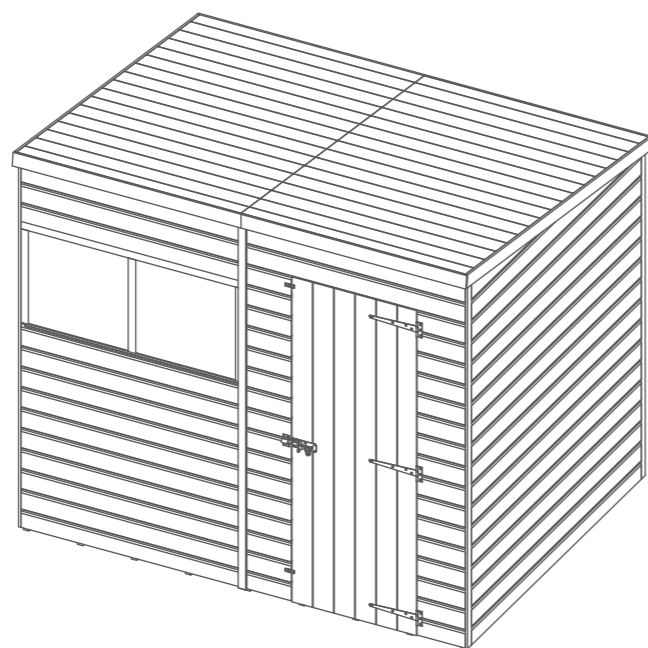

Contents:

1

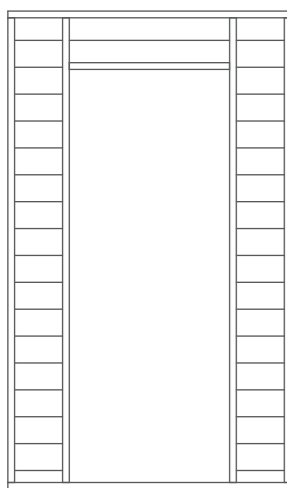

Door Panel QTY 1

AI-01S11SHSD1180X2012-V1

2

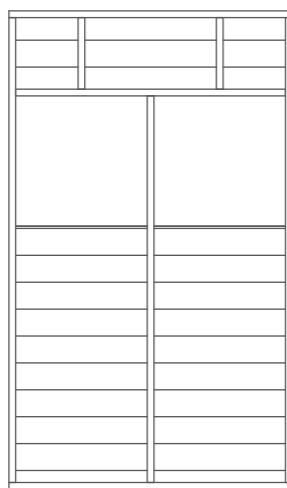

Window Panel QTY 1

AI-01S11SH2CW1180X2012-V1

3

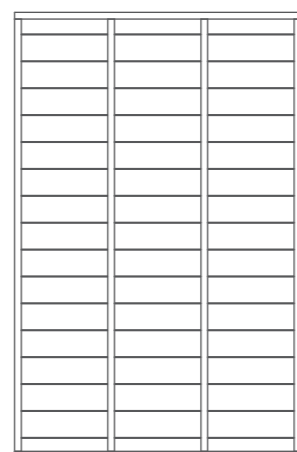

Roof QTY 2

AI-S11MBPR1856X1192-V1

4



Plain Panel QTY 2

AI-S11SHPP1180X1792-V1

5

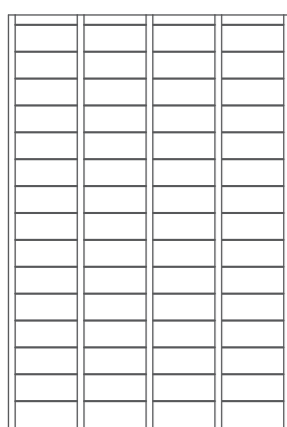

Floor QTY 2

AI-R11MBF1175X1753-V1

6

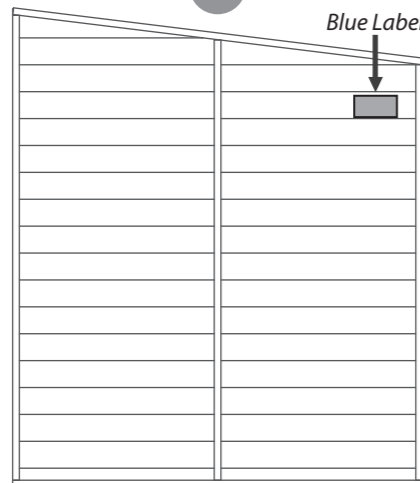

Left Gable QTY 1

AI-01S11SHPGL1707X2015-V1

7

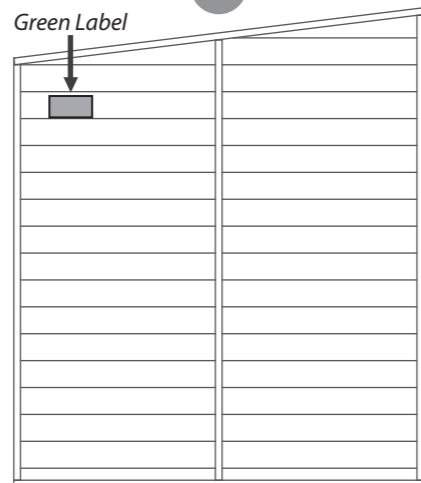

Right Gable QTY 1

AI-01S11SHPR1707X2015-V1

8

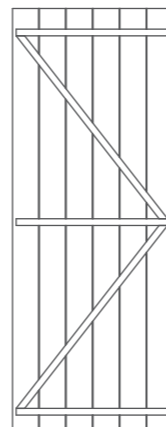

Door QTY 1

AI-S11FBMBZBD661X1780-V1

9

Ridge Bar 27x44x1152mm QTY 2
F2744-1152mm

10

Door Block 28x28x140mm QTY 1
FS2828-140mm

11

Eaves Framing 28x28x1192mm QTY 4
FS2828-1192mm

12

Window Strips 12x28x554mm QTY 4
S1228-554mm

13

Window Cover Trims 12x40x513mm QTY 3
S1240-513mm

14

Window Cover Trim 12x40x1180mm QTY 1
S1240-1180mm

15

Back Cover Trims 12x40x1792mm QTY 3
S1240-1792mm

16

Front Cover Trims 12x40x2012mm QTY 3
S1240-2012mm

17

Fascias 12x70x1856mm QTY 2
S1270-1856mm

18

Fascias 12x70x1204mm QTY 4
S1270-1204mm

19

Door Beading Strips 12x28x1720mm QTY 2
S1228-1720mm

20

5m Green felt QTY 1
PI-01-0013

21

Turn Button QTY 2
PI-07-0034

22

Corner Brace QTY 2
PI-07-0012

23

U-Channel QTY 1
PI-07-0013

24

Styrene QTY 2
PI-05-0114

25

T-Hinge QTY 3
PI-07-0021

26

Pad Bolt QTY 1
PI-07-0035

27

Window Cill QTY 1
PI-08-0013

IMPORTANT: Pre-drill before fixing screws.

Nail Bag

There may be extra screws present in the nail bag

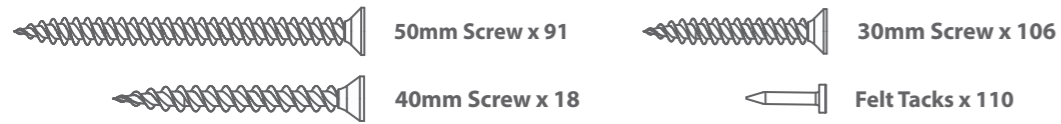

Step 1

Parts needed - No. 5 QTY 2

Place the floor panels (**No.5**) onto a firm and level base. Ensure the base has suitable drainage, free from areas where standing water can collect.

Secure the floors together using 8x50mm screws through the floor bearers in an alternating pattern.

8x50mm Screws

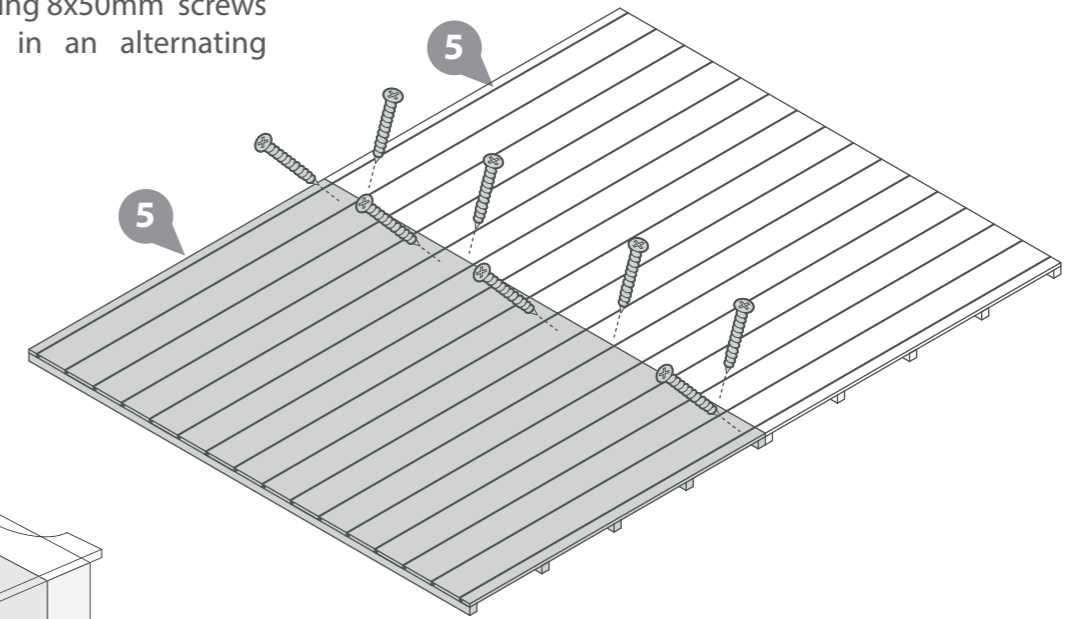

Pre Assembly

Before assembling remove the transportation blocks from the bottom of each panel.

Take care removing the blocks as to not damage the panels. Tap with a flat headed screwdriver and hammer.

Dispose of the blocks once removed.

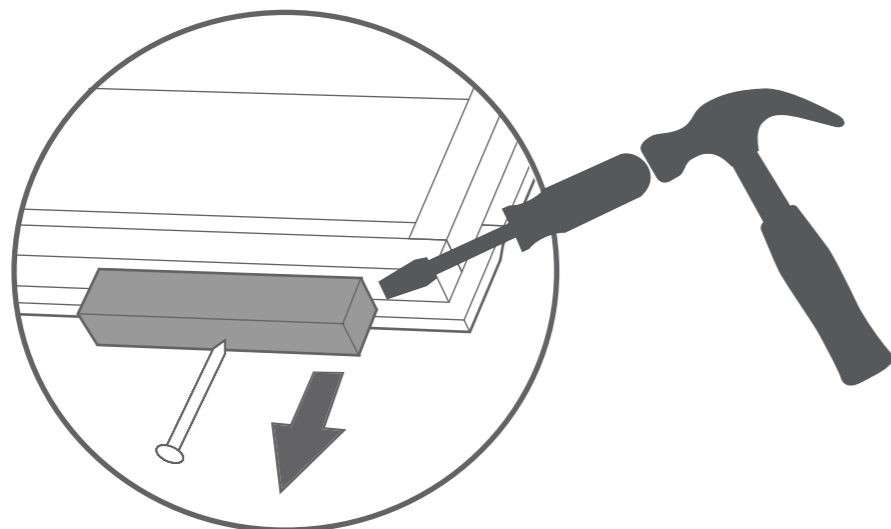

Step 2

Parts needed - No. 1 QTY 1
No. 8 QTY 1
No. 25 QTY 3

Place the door (No.8) within the Door Panel (No. 1). Fix the T Hinges (No. 25) onto the door and Door Panel as shown (taking into account on which side of the Door Panel opening you want the Door to open).

Ensure that the screws go through the cladding and into the framing behind.

21x30mm Screws



****PLEASE NOTE**** Before fitting the hinges, ensure the door is in the correct position depending on which side you want the door to open. See external illustrations below which show the doors internal framing.

Opens from the Left

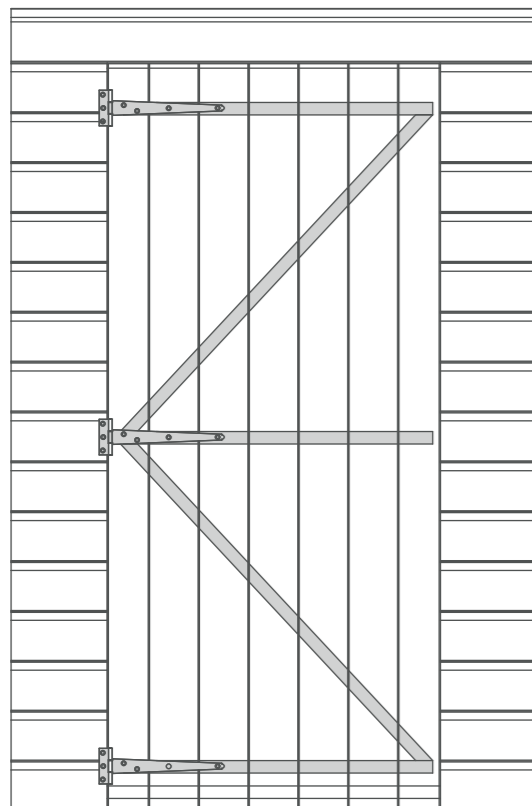

Opens from the Right

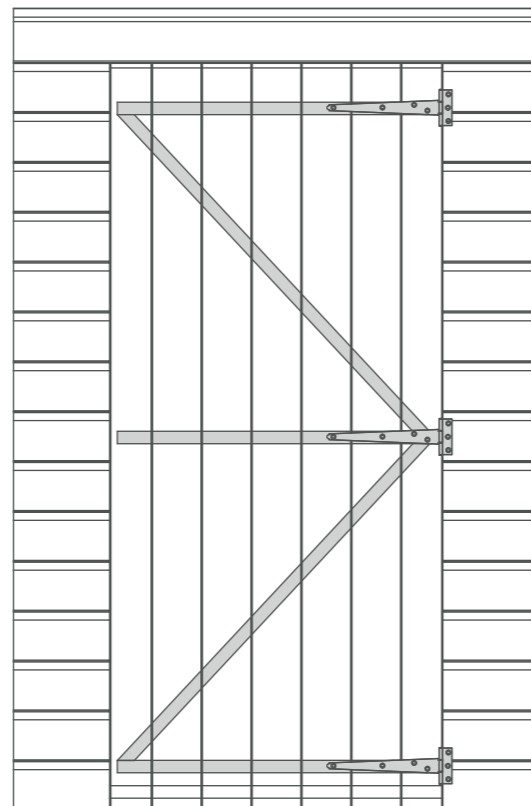

IMPORTANT: Pre-drill before fixing screws.

PLEASE SCAN HERE:

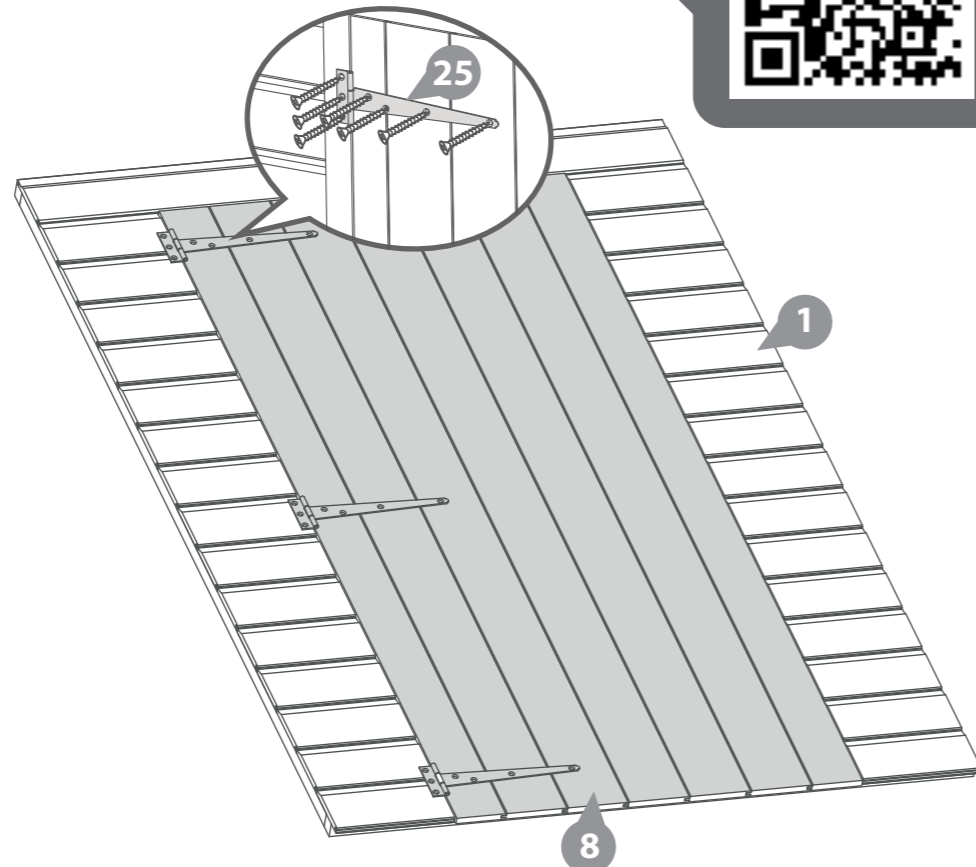

Step 3

Parts needed - No. 4 QTY 1
No. 6 QTY 1

Place the Left Gable (No.6) and the Plain panel (No.4) onto the floor, Fix the panels at the corner using 3x50mm Screws

Do not secure the building to the floor until the roof has been fitted.

Position the panels so there is equal spacing between the floor and cladding on all sides.

3x50mm Screws

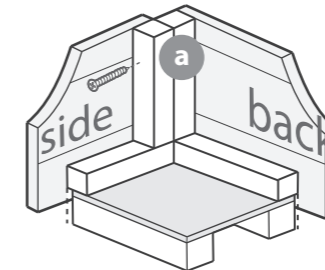

IMPORTANT: Pre-drill before fixing screws.

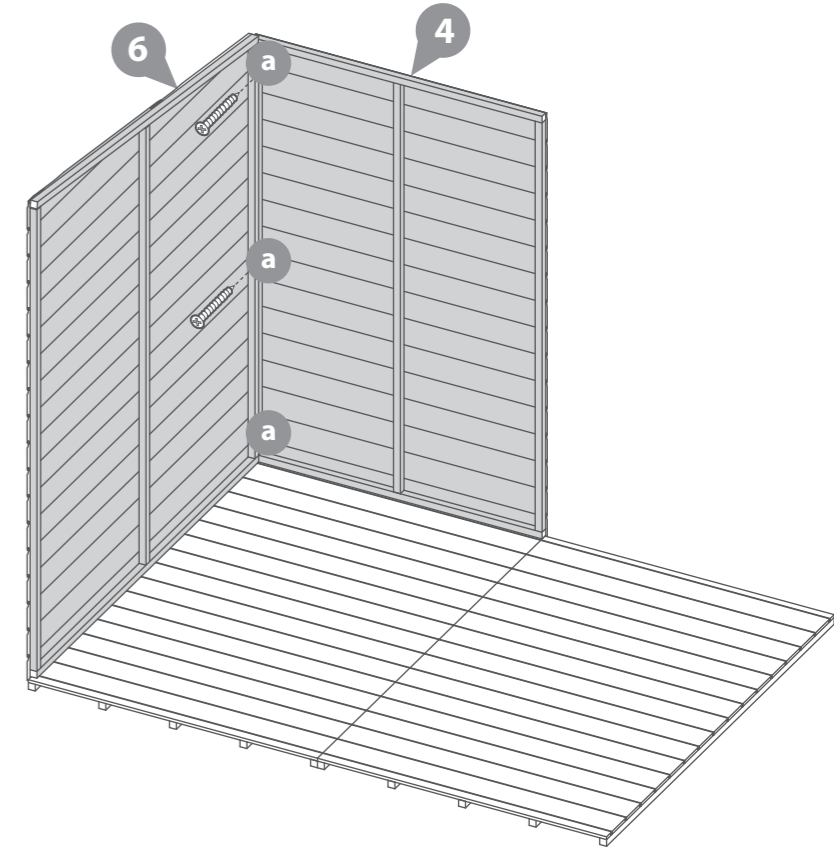

Step 4

Parts needed - No. 2 QTY 1
No. 4 QTY 1

Fix the corners of the Window panel (No.2) to the Left Gable using 3x50mm screws.

Fix the ends of the Plain panels (No.4) together using 3x50mm screws.

Do not secure the building to the floor until the roof has been fitted.

Position the panels so there is equal spacing between the floor and cladding on all sides.

6x50mm Screws

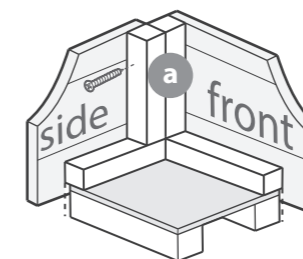
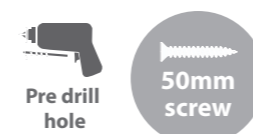

IMPORTANT: Pre-drill before fixing screws.

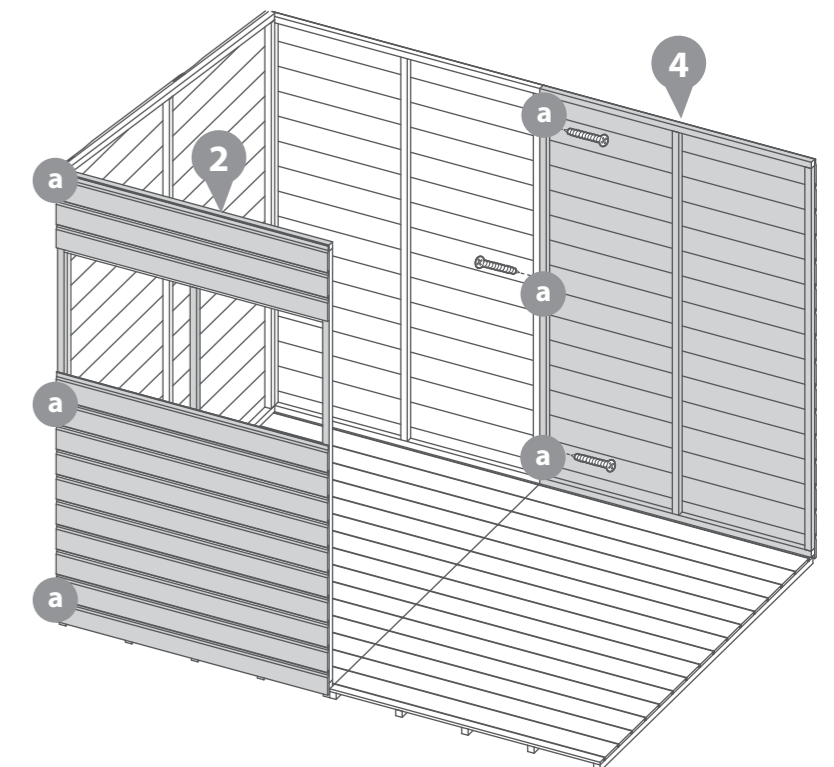

Step 5

Parts needed - No. 1 QTY 1
No. 7 QTY 1

Fix the corners of the Right Gable (No.7) to the Plain Panel and the Door Panel (No.1) using 6x50mm screws.

Fix the end of the Door panel (No.1) to the Window panel using 3x50mm screws.

Do not secure the building to the floor until the roof has been fitted.

Position the panels so there is equal spacing between the floor and cladding on all sides.

9x50mm Screws

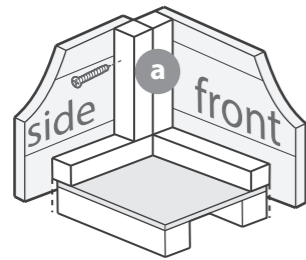

IMPORTANT: Pre-drill before fixing screws.

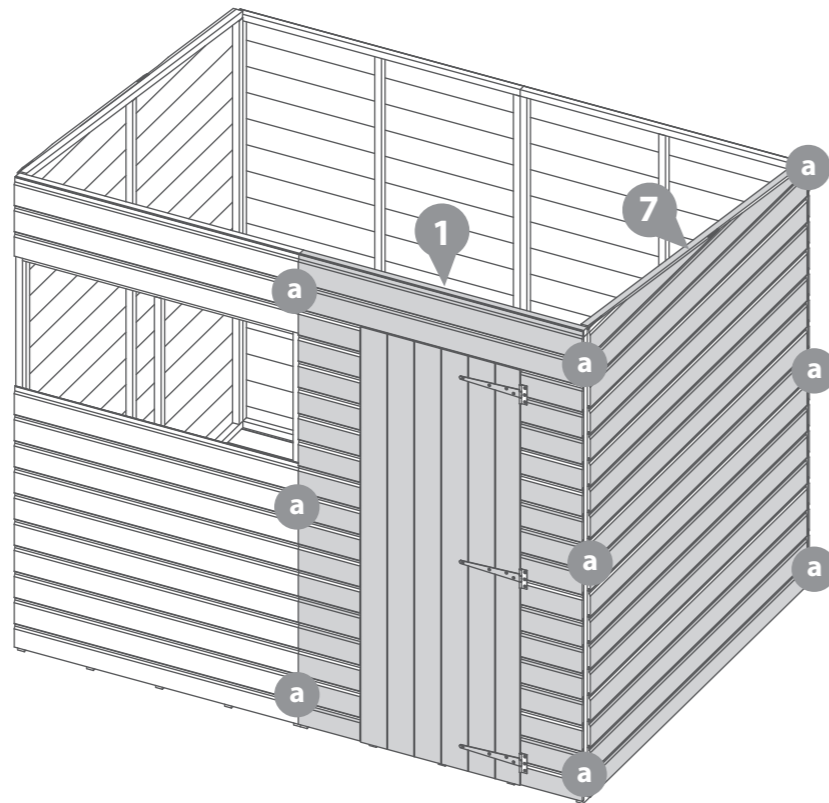

Step 7

Parts needed - No. 9 QTY 2
No. 22 QTY 2
No. 23 QTY 1

Connect the two Ridge Bars (No.9) together with the metal U-channel (No.23) using 10x30mm screws. Ensure the ridge bar sits into the U-channel with equal spacing on each side.

Attach the "L" shaped corner braces (No.22) to each end of the ridge bar with 2x30mm screws per bracket.

***Ensure the bracket are flush with the ends of the ridge bar.**

14x30mm Screws

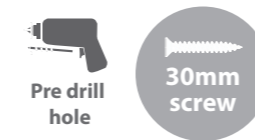

IMPORTANT: Pre-drill before fixing screws.

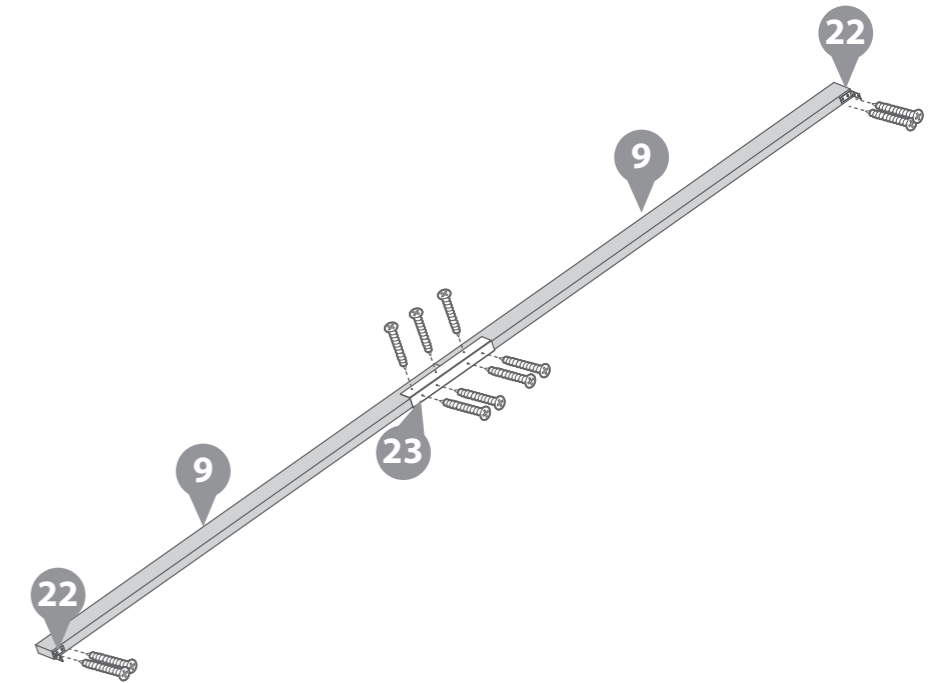

Step 6

Parts needed - No. 3 QTY 2
No. 11 QTY 4

Fix the Eaves framing (No.11) to the roof (No.9) using 3x30mm screws per eaves framing, screwing through the eaves framing and into the roof framing.

Ensure the eaves framing is flush to the edges of the roof framing before securing

Repeat the above for the second roof panel

12x50mm Screws



IMPORTANT: Pre-drill before fixing screws.

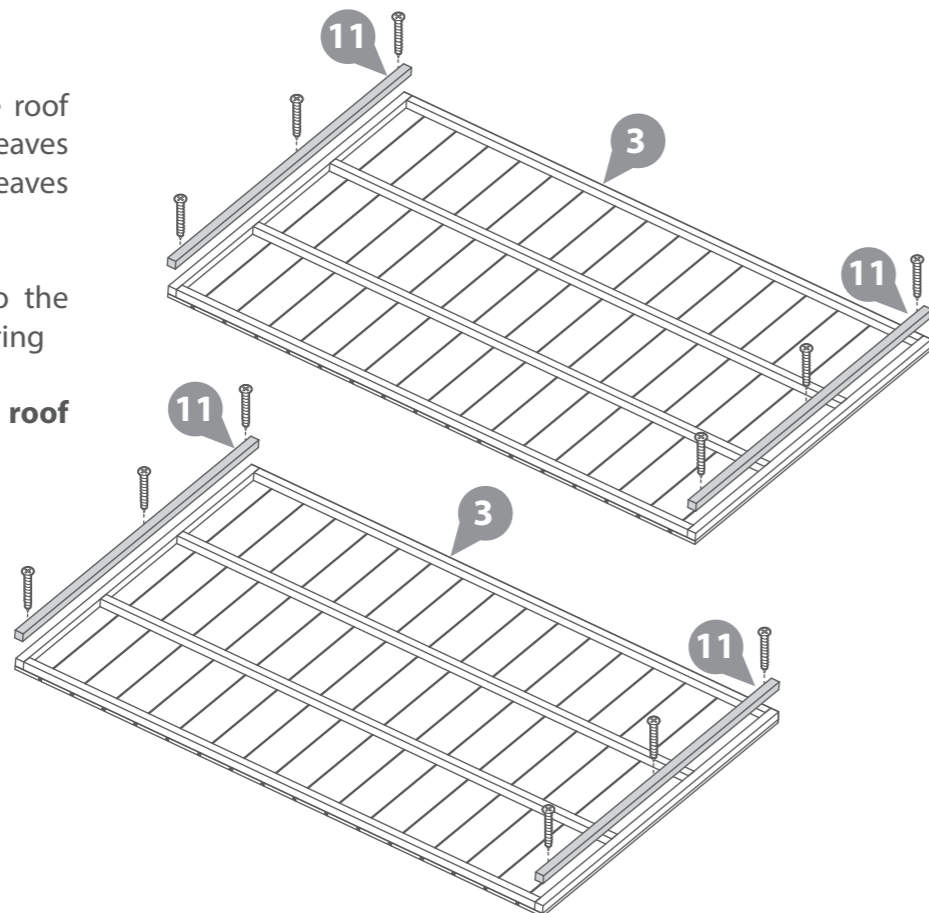

Step 8

Parts needed - No. 9 QTY 1
No. 22 QTY 2

Locate the assembled Ridge Bar (No.9) inbetween the two gable panels, ensuring the ridge bar is aligned with the central framing and flush to the top of the panels framing.

Fix the Ridge Bar (No.9) in place using the Corner Braces (No.22). Secure using 2x30mm screws per corner brace.

4x30mm Screws

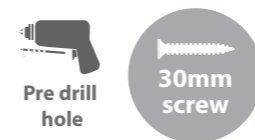

IMPORTANT: Pre-drill before fixing screws.

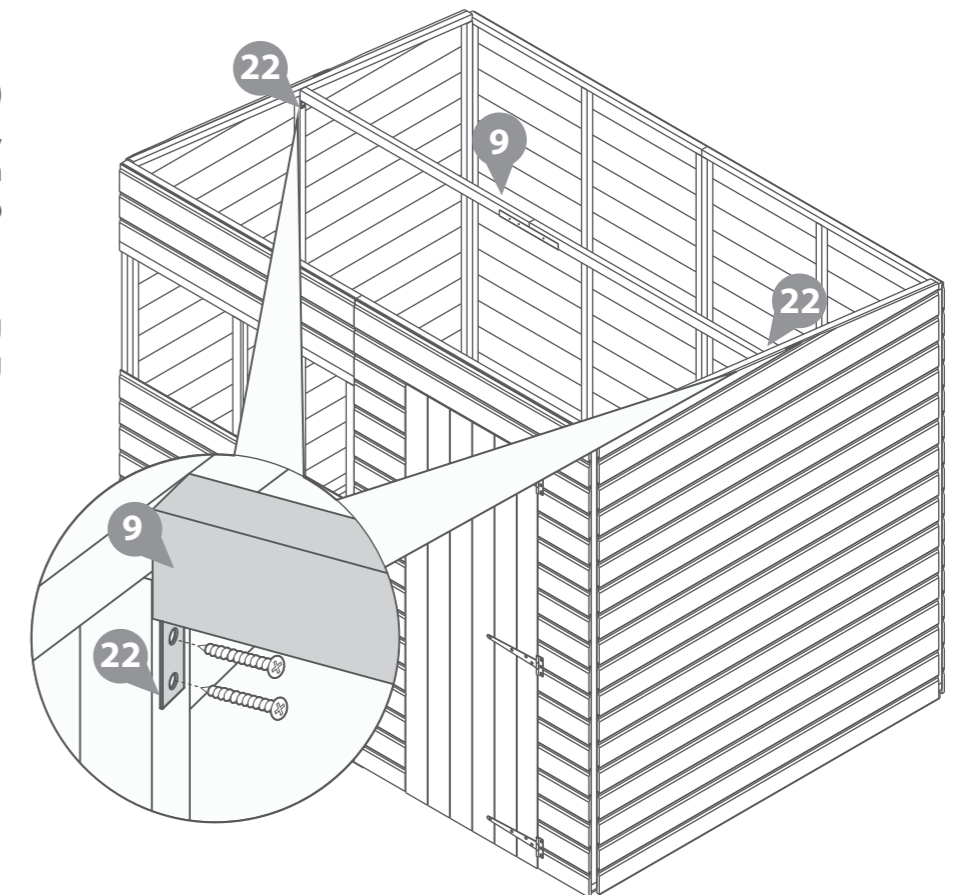

Step 9

Parts needed - No. 3 QTY 2

Place the Roof Panels (No.3) on top of the building making sure the framing in the roof panels sits flush with the gable panels and there is equal spacing at the front and back of the building.

Internally: Secure the roof panels together using 5x50mm screws through the framing as shown in the diagram.

Secure roofs to the building and ridge bar using 28x50mm along each side of the roof, ensuring there is no more than 300mm between each screw and the screws go through the roof framing and into the panel framing.

33x50mm Screws



Internal view

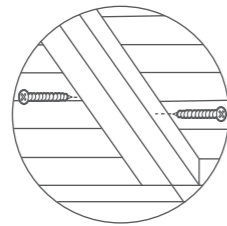

IMPORTANT: Pre-drill before fixing screws.

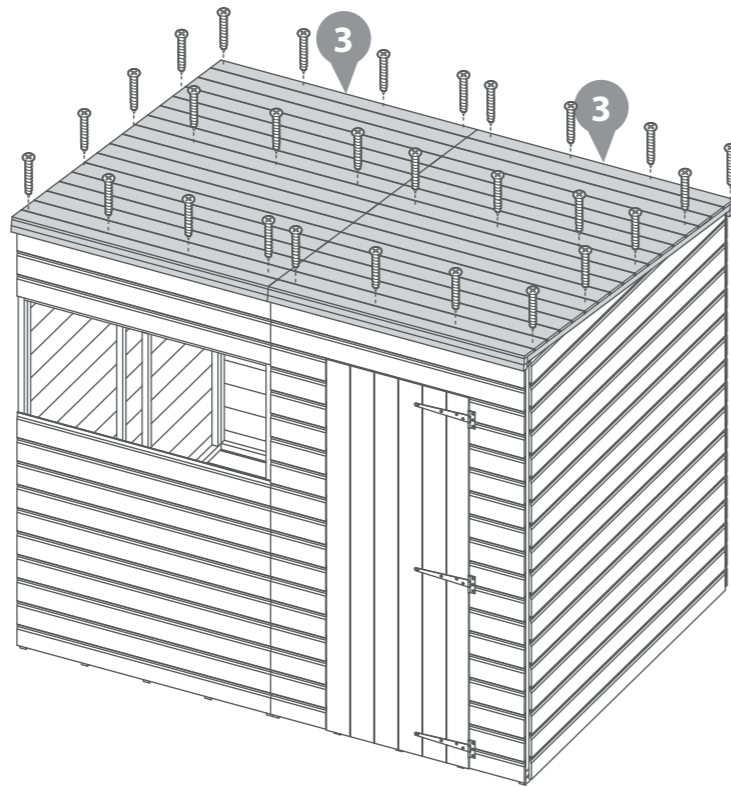

Step 10

Once the roof is fixed, attach the building to the floor with 50mm screws.

Ensure the screws go through the panel into the floor framing

20x50mm Screws

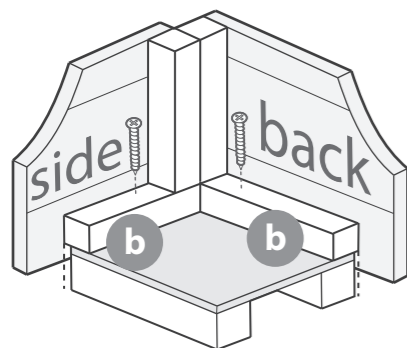

IMPORTANT: Pre-drill before fixing screws.

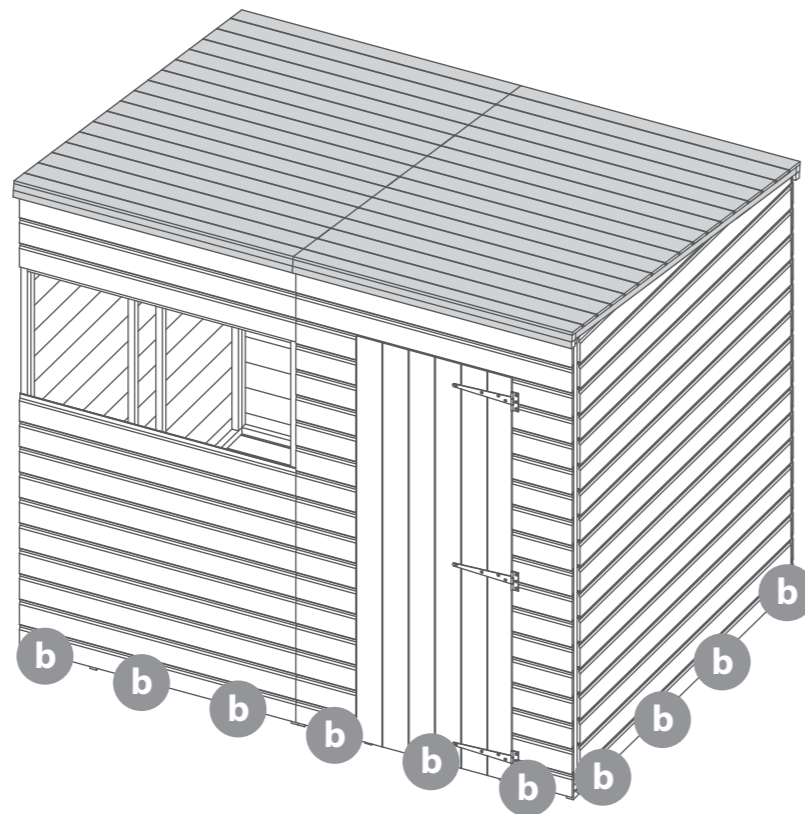

Step 11

Parts needed - No. 20 QTY 1

Cut the felt (No. 20) into two sheets at 2500mm (L) x 1000mm (W).

Lay onto roof as shown in diagram, ensuring there is a 50mm overhang around the sides and the sheets overlap by 100mm.

Secure in place using the felt tacks with a 100mm space between each tack.

110 x Felt Tacks

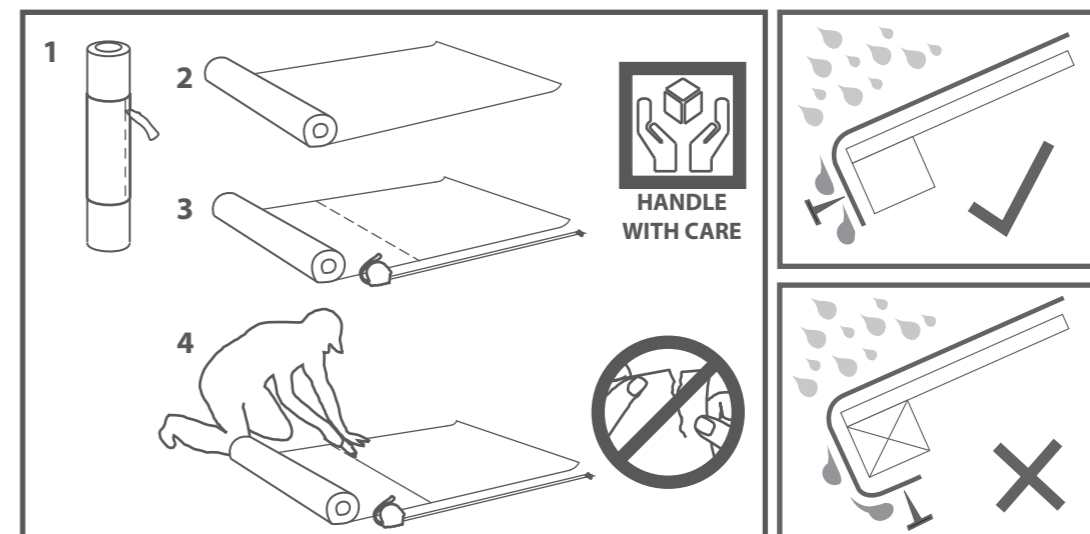
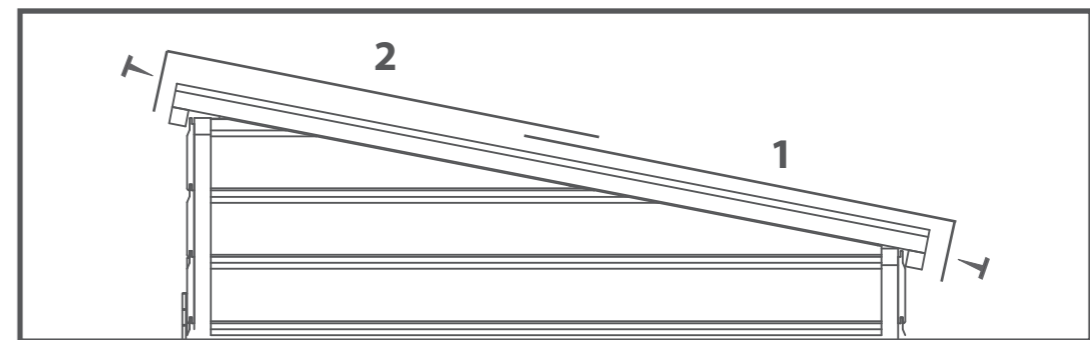
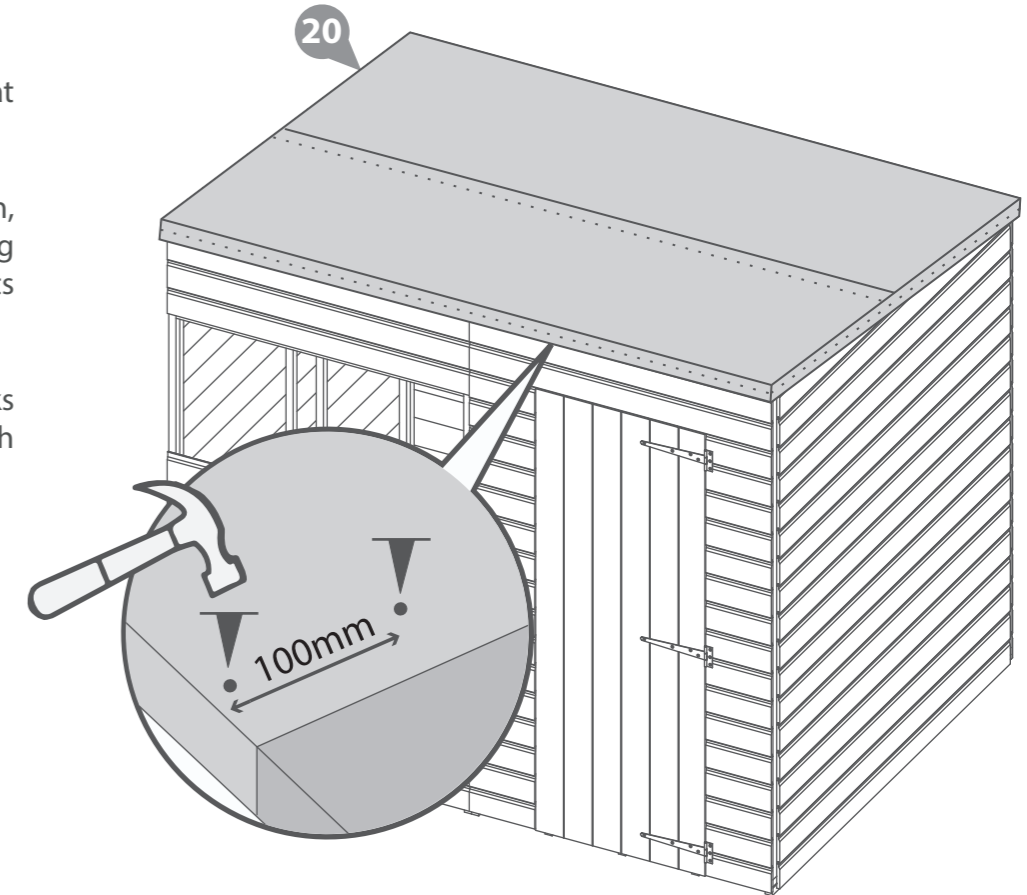

Step 12

Parts needed - No. 12 QTY 4
 No. 13 QTY 3
 No. 14 QTY 1
 No. 24 QTY 2
 No. 27 QTY 1

- Fix 4x window strips (No.12) to the framing along the outside edge of the window gap using 3x30mm screws per strip.
- Place the Plastic Window Cill (No.27) into the window panel (No.2) opening as shown in the illustration. Fix screws through the cill for extra support using 3x30mm screws.
- Fit the styrene sheets (No.24) on top of the window cill (No.27).

**For added weather protection fit your windows using silicone sealant around the outside edges.*

***When positioning the styrene sheets ensure there is an equal distance on all sides.*

- Attach the longer Window cover trim (No.14) along the top of the window opening.

Followed by attaching 3 shorter window cover trims (No.13) to either side of the windows and between the two windows.

Secure into place using 3x30mm screws per strip.

27x30mm Screws

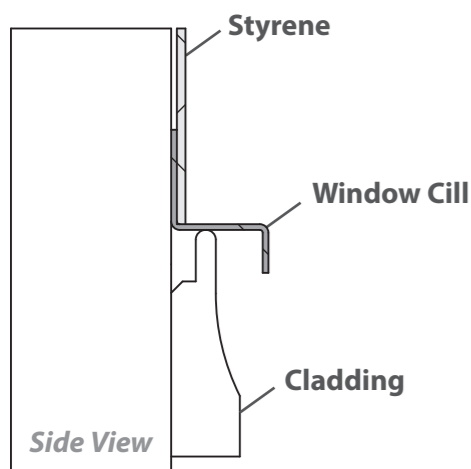
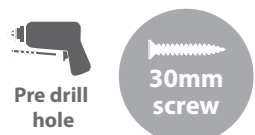

IMPORTANT: Pre-drill before fixing screws.



Step 13

Parts needed - No. 10 QTY 1
 No. 19 QTY 2

- Use 4x30mm Screws to fix each beading strips (No. 19) onto the insides of the door Panel opening. Ensure that the screw is parallel with the door frame when fixing the strip to the Door Panel as shown in the close up view.
- Attach the Door Block (No. 10) to the door using 2x30mm screws, in the positions illustrated. Screw through the door cladding into the blocks using 30mm screws

10x30mm Screws

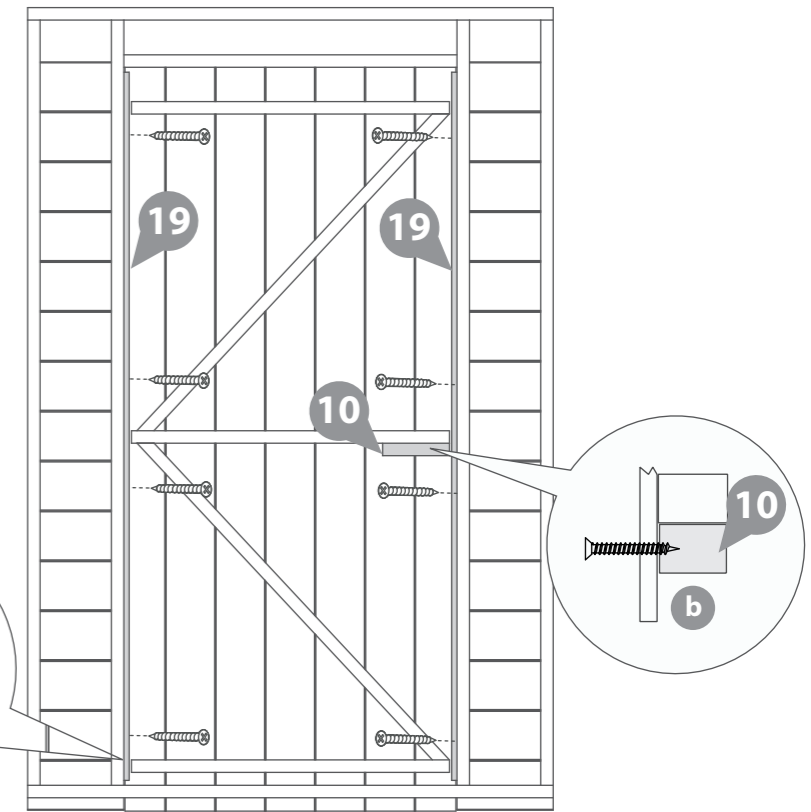
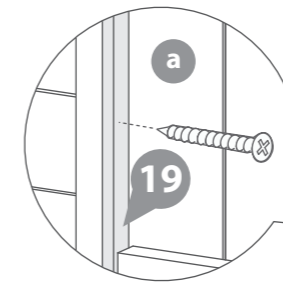

Step 14

Parts needed - No. 21 QTY 2
 No. 26 QTY 1

Screw the Pad Bolt (No. 26) on to the door and the retainer to the door panel using 10x30mm screws. Make sure that you screw into the framing behind.

Fix the Turn Button (No. 21) onto the Door Panel using 1x30mm screw for each one.

These turn buttons help to keep your doors straight during high and low levels of moisture content in the air.

12x30mm Screws.

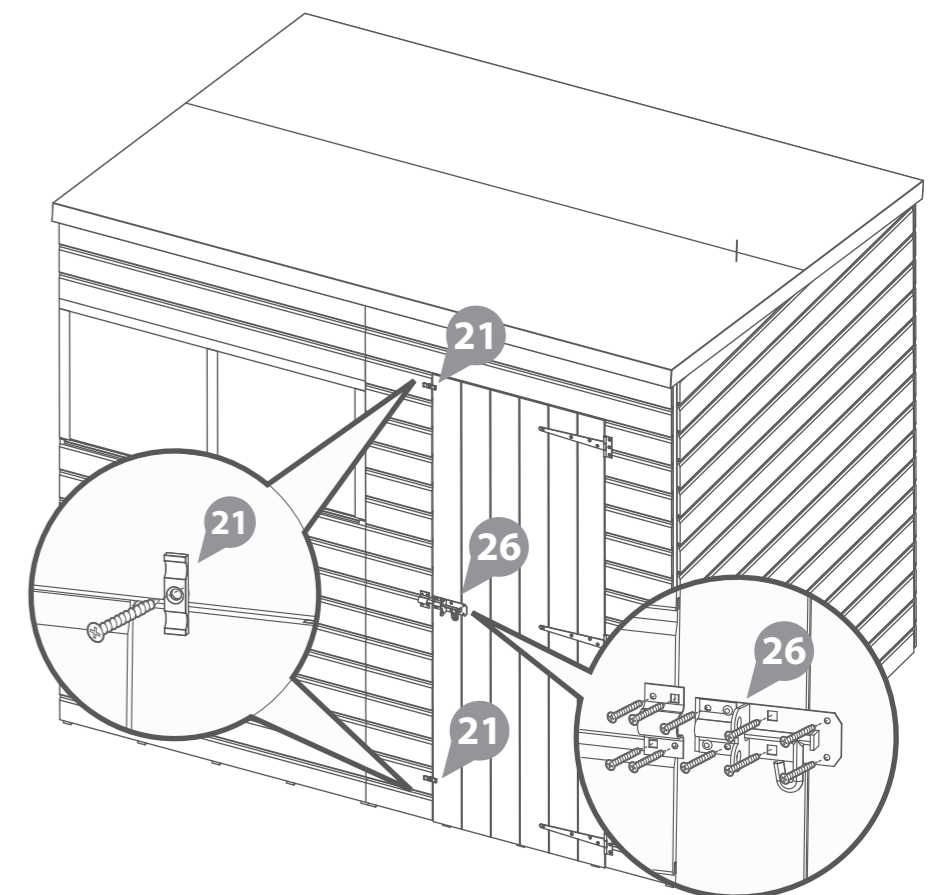

Step 15

Parts needed - No. 17 QTY 2
No. 18 QTY 4

Locate the Fascias (No.17) onto the sides of the building, ensuring to trap the felt between. Secure using 3x40mm screws per Fascia.

Locate the Fascias (No.18) onto the front and back of the building, ensuring to trap the felt between. Secure using 3x40mm screws per Fascia.

Pre drill to avoid splitting

18x40mm Screws.

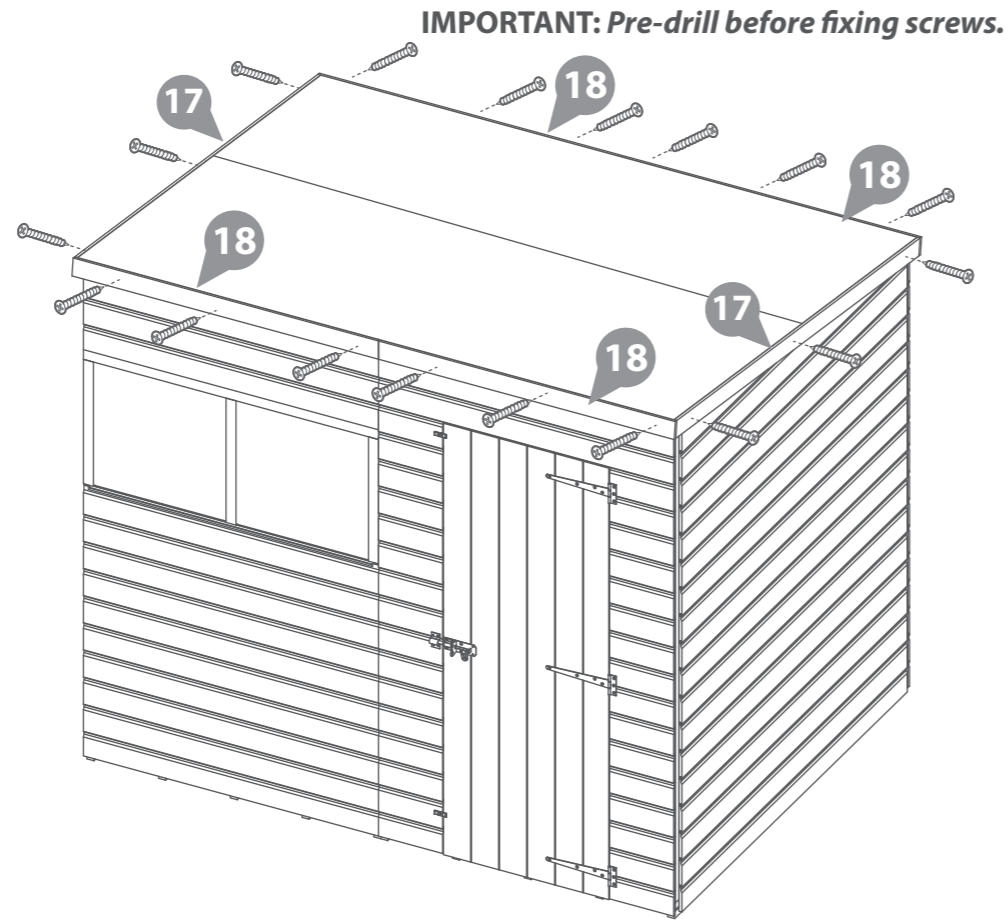
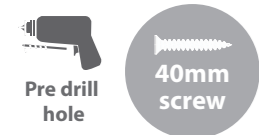

Step 16

Parts needed - No. 15 QTY 3
- No. 16 QTY 3

Fit the Cover trims (No.15 and No.16) over each panel join and corner of the building as shown using 3x30mm screws per cover trim.

Pre drill to avoid splitting. Cover trims may need cutting to size before fitting.

18x30mm Screws.

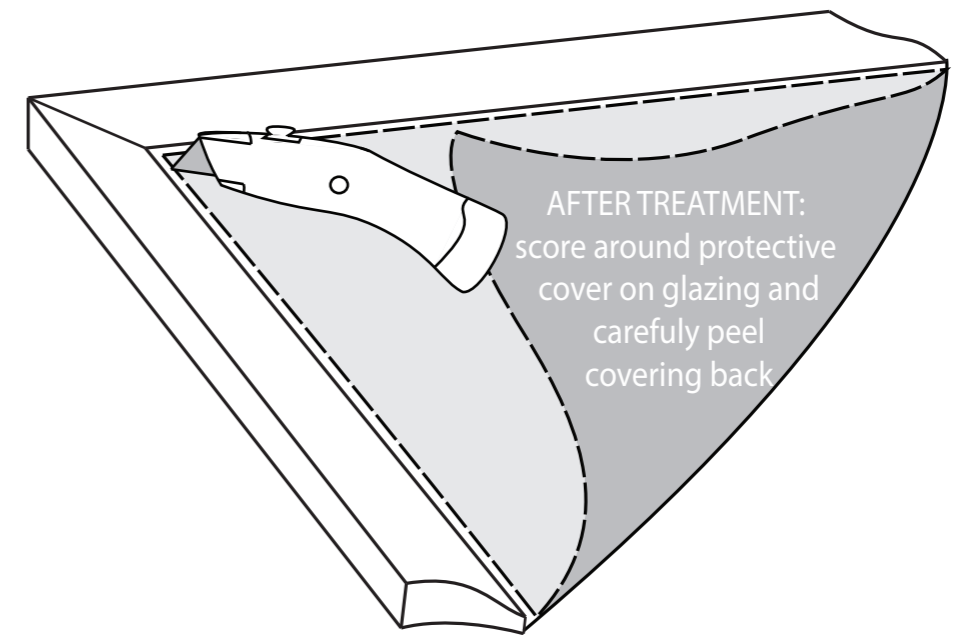
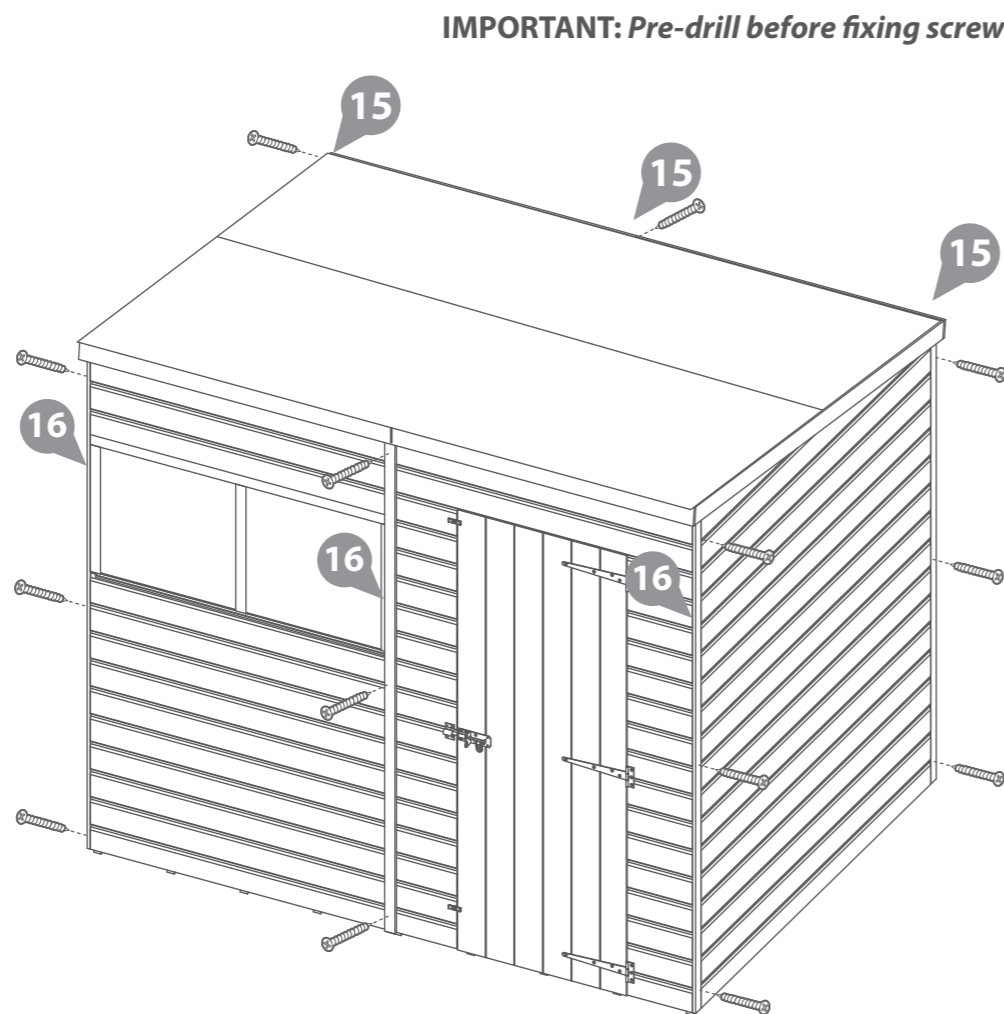
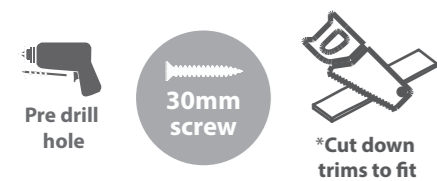

LEAVE US A REVIEW...

Want to share your experience with us? Leave us a review on Feefo, TrustPilot or Google.

Your reviews help other people find and trust our business, as well as helping to play an important role in our growth and improvement!

TREATING YOUR GARDEN BUILDING

Preservation of wood that's outdoors is vital. A little early care will help protect your garden building, improve its appearance and ensure maximum longevity. Insects, moisture, salt, and changing weather can have dramatic effects on the stability and appearance of your garden building. Once your building is installed, you've checked it over and you're happy with it, you can take a few basic precautions to prepare it for the elements. Treating your garden building helps prevent decay and, by repelling water, discourages the growth of moulds and fungi that could jeopardise the structural integrity of the wood.

Dip Treated buildings - Require a preservative treatment to protect against rot and decay and a waterproof treatment to prevent water ingress
Pressure Treated buildings - Require a waterproof treatment to prevent water ingress
Log Cabins/Insulated Garden Rooms - Are supplied untreated and require a preservative and waterproofing treatment.



ANY QUESTIONS?
Scan the QR code to contact us via our customer portal.

To apply a preservative and water proofing treatment (pressure treated products do not require a preserver), follow the manufacturer's instructions but in principle, stick to the following steps:

- ✓ Wear latex or rubber gloves, eye protection and (if spraying) a mask.
- ✓ Prepare the wood, by sanding down any ridges or inconsistencies in the wood, smoothing out knots and end-cuts.
- ✓ Choose a dry day to treat your garden building. If you're spraying rather than brushing paint on, avoid a windy day.
- ✓ Be sure you can safely reach all the sections you need to paint - and if you need a ladder, make sure it's safely positioned before climbing. Lay dust sheets around to avoid paint splatters on your base or surrounding plants.
- ✓ Tape around windowpanes to avoid smears when you're painting the frames.
- ✓ Keep pets and small children out of the way. The last thing you want is to have fur on your garden building paint, or little painted footprints all over your garden and home.
- ✓ Fill any gaps in the building's body with caulk or wood filler to prevent water and draughts getting in. Silicone based caulk is flexible and will move with the timber when temperature and humidity change. Allow to dry completely before treating. A handy tip for finding gaps is to go into your garden building and look for light leaking through joins and frames. If light gets in, then so will water.
- ✓ Liberally apply at least two coats of the treatment products with a brush or spray, taking care to allow the first coat to completely dry before applying the second.
- ✓ Make sure the solution permeates the whole of the surface area, especially around natural cracks, end cuts and nail/screw holes.



APPLY WOOD TREATMENT
IMMEDIATELY
AFTER ASSEMBLY

PLEASE SCAN HERE TO
SEE TREATMENT VIDEO:



1 Perimeter

Check around the perimeter of your product to ensure there are not trees or plants that are in contact with or overhanging the building. This can affect airflow and overhanging trees, or branches can damage the roof, it is advised to keep plants at a distance.

2 Repair

Inspect the interior and exterior of the product to look for splits, cracks, and holes. Although this is a natural occurrence it can be prevented. A wood filler can be used to close the splits, cracks, and holes.

3 Roof

Check your roof regularly for tears, splits, damaged wood and fallen debris. If you notice any of this immediate repair is critical.

4 Doors & Windows

Expansion and contraction can cause doors and windows to stick or become difficult to open. Small adjustments to the hinge position can be made to the doors and windows to allow free movement.

5 Oil

Hinges can seize up over time, apply lubricant to the hinges and locks annually.

6 Screws & Bolts

It is advised to check all screws and bolts and tighten any loose you might find. For log cabins specifically the storm braces will require loosening. During humidity and temperature changes (seasons) to allow expansion and contraction to prevent gaping, twisting, popping, and warping.

7 Wash

At least once a year, give the outside of you building a good wash, to remove cobwebs, leaves, or any other dirt that may accumulate on the exterior.

8 Airing

Airing your product regularly prevents the build up of condensation which can cause the timber to rot and mould. Condensation can build up over time or daily, it is caused by a rise and fall in temperature. Leaving doors and windows open regularly can help combat the natural moisture build up.

9 Clean & Tidy

It is good practice to clean the inside and outside of your product regularly. Clear out the contents, sweep the floor, remove dirt and cobwebs. Check for areas of damp and investigate the cause to remove and prevent future occurrences. Check the ground around your product for build up of debris such as leaves, remove and ensure there is clear ventilation underneath the floor.

Additional Playhouse Maintenance:

It is recommended that the following checks and maintenance are carried out at the beginning of each season as well as at regular intervals during the usage season.

- Check all nuts /bolts/ screws for tightness and tighten when required.
- Check for movement / opening of wood giving rise to protrusion of nail heads and tips.
- Check hinges.
- Replace defective parts in accordance with the manufacturers instructions.
- Check any crossbeams, suspensions and anchors.
- If a swing is included; check the swing seat, chains and ropes.

IF THESE CHECKS ARE NOT CARRIED OUT THE ACTIVITY TOY COULD BECOME A HAZARD

All our garden buildings have been designed and manufactured with care and attention to be the perfect addition to your outdoor space. To ensure you do get the best out of your new garden building and to increase the longevity we advise that you follow the product instructions and our manufacturer's recommendations as detailed below. Thank you for choosing a Mercia Garden product!

1 Choosing the most suitable location for your garden building...

A minimum of 60cm should be left around the perimeter of your garden building to allow access for maintenance, annual treatment and to allow air flow around the building.

Where possible you should avoid placing your garden building underneath large trees to prevent the tree causing damage to the building.

2 Preparing the base for your garden building...

All our buildings must be built on a firm, level base to ensure the longevity of the building and prevent the wood from distorting. We recommend either concrete, concrete slabs or a wooden base, such as our 'Portabase'.

The base should be slightly smaller than the external measurement of the building, i.e. the cladding should overlap the base, creating a run off for water and preventing water from pooling underneath the building.

We also recommend that the floor of the garden building is a minimum of 25mm above the surrounding ground level to avoid flooding.

3 After installation...

Once your garden building has been installed, it will need to be treated within 14 days (weather permitting) and annually to prevent the timber from deteriorating and to waterproof it. This is required to maintain the anti-rot guarantee.

Dip Treated buildings - Require a preservative treatment to protect against rot and decay and a waterproof treatment to prevent water ingress.

Pressure Treated buildings - Require a waterproof treatment to prevent water ingress.

Log Cabins/Insulated Garden Rooms - Are supplied untreated and require a preservative and waterproofing treatment.

We also recommend using a silicon sealant on the inside and outside of the windows as soon as possible after assembly and treatment to fully seal the windows.

Roofing felt/covering should be checked annually and replaced or fixed accordingly.

4 General maintenance and wood characteristics

As wood is a natural material it may be affected by the following:

Shrinkage and warping - The timber used in the construction of your garden building will have retained some of its natural moisture content. The moisture content of the timber will vary, depending upon prevailing environmental conditions, which will result in the components either naturally expanding or contracting. As the components dry out, shrinkage may occur. A good waterproofing treatment from the start is the best protection to minimise the effect of moisture loss/intake.

In extended periods of very warm weather getting some moisture to the building will help the overall balance. You can do this by spraying it down lightly with a garden hose. In contrast, after snow fall try to remove the snow as best as possible from the roof to prevent moisture intake and to remove the extra weight.

Top tip - using a garden brush will help you to reach the highest part of the building to remove snow and any debris left from bad weather.

Damp and mould - During the winter months, cold and damp conditions can result in an increased amount of moisture within your garden building, especially when used infrequently. Condensation can form on the timber and other items stored within your garden building. If left this moisture is likely to cause mould and mildew.

To prevent the build-up of moisture, we recommend leaving the door or windows of your building open from time to time, to allow the fresh air to circulate. We also advise against storing wet or damp items in your garden building as this will also increase the level of moisture in the building. If mould or mildew does start to form within your building we recommend using an anti-mould cleaner to remove it and to prevent it spreading, which if left untreated could permanently damage your garden building.

Splits, cracks and knots - You may notice small splits and cracks in some components or holes may appear where knots shrink and fall out. This will not affect the structure of your Garden building however, if you wish to fill them this can be easily done using any good quality wood filler.

Sap - is naturally occurring in wood and may appear in some boards of your garden building. If you wish to remove the sap, we advise waiting until it is dry and then using a sharp knife to carefully remove it. If the removal of the sap causes a hole in the timber, we recommend using a good quality wood filler to fill it.

For more handy hints and tips on how to care and maintain your garden building please refer to the MGP Customer Portal at www.mgplogistics.co.uk

Any further questions?

Contact our
Customer Service Team via the MGP
Customer Portal at:
www.mgplogistics.co.uk

1 Manufacturer's Warranty

All Mercia Garden Products are supplied with a 1 year warranty on all parts against manufacturing defects.

This warranty does not cover movement, warping or splitting of timber products over time.

This warranty will be voided if any of the following occur:

1. The building has been customised or modified/adapted in any way.
2. The person claiming is not the original purchaser of the building.
3. Any damage has been caused by or as a result of misuse.
4. The building has not been maintained and cared for in accordance to our advisories and manufacturer's recommendations.
5. The building has not been treated annually or as per the manufacturer's recommendations, please ensure receipts are kept to validate this claim.
6. The building has not been erected, fitted or installed as per the supplier instructions.
7. The building has not been erected on a suitable sized firm flat, solid level concrete/slab base or placed on pressure treated bearers.
8. The building is or has been placed with 2 feet (600mm) of any obstructions (walls, trees, plants, fences etc.) which can allow moisture to penetrate the timber.
9. The roofing felt has been incorrectly fitted or damaged, allowing water ingress, or has not been properly maintained.
10. Any windows and joints have not been sealed, inside and out, with silicone or other watertight sealant.
11. Any timber has been cut, pierced or drilled without subsequent application of approved cut-end treatment.

2 Anti-rot Guarantee

Mercia Garden Products offer a 10 year anti-rot guarantee on all dip treated (a preparatory treatment) and 15 years on all pressure treated products. This guarantee covers solid timber against rot, decay, blue stain and insect attacks.

To validate the guarantee, the building must be treated (as detailed within manufacturer's recommendations) within 14 days (weather permitting) of assembly and annually thereafter.

This guarantee does not cover movement, warping or splitting of timber products over time.

This guarantee will be voided if any of the following occur:

1. The building has been customised or modified/adapted in any way.
2. The person claiming is not the original purchaser of the building.
3. Any damage is caused by or as a result of misuse.
4. The building has not been maintained and cared for in accordance to our advisories and manufacturer's recommendations.
5. The building has not been treated annually or as per the manufacturer's recommendations, please ensure receipts are kept to validate this claim.
6. The building has not been erected, fitted or installed as per the supplier instructions.
7. The building has not been erected on a suitable sized firm flat, solid level concrete/slab base or placed on pressure treated bearers.
8. The building is or has been placed with 600mm of any obstructions (walls, trees, plants, fences etc.) which can allow moisture to penetrate the timber.
9. The roofing felt has been incorrectly fitted or damaged allowing water ingress, or has not been properly maintained.
10. Any windows and joints have not been sealed, inside and out, with silicone or other watertight sealant.
11. Any timber has been cut, pierced or drilled without subsequent application of approved cut-end treatment.



REGISTER FOR YOUR
ANTI-ROT
GUARANTEE TODAY

PLEASE SCAN HERE:

