

**10DTSHAX0806-V1**  
**8X6 SHIPLAP APEX DOG KENNEL / RUN.**



**x2** All buildings should be erected by two adults



Winter = High Moisture = Expansion  
 Summer = Low Moisture = Contraction



**2mm Drill bit**

For ease of assembly, you **MUST** pilot drill all screw holes and ensure all screw heads are countersunk.



**CAUTION**  
 Every effort has been made during the manufacturing process to eliminate the prospect of splinters on rough surfaces of the timber. You are strongly advised to wear gloves when working with or handling rough sawn timber.



For ease of assembly, you will need a tape measure to check dimensions of components.

**Screws & Nails**



**Bolts**

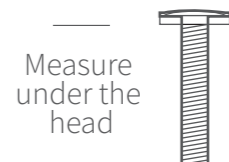

To identify the fixings required for each step use a measuring tape.

**\*\*Protim Aquatan T5 (621)\*\***

Your building has been dip treated with Aquatan.

Aquatan is a water-based concentrate which is diluted with water, the building as been treated by the correct application of Aquatan solution and then allowed to dry.

Aquatan is a decorative finish to colour the wood, which is applied industrially to timber fence panels and garden buildings.

Aquatan undiluted contains: boric acid, sodium hydroxide 32% solution, aqueous mixture of sodium dioctyl sulphosuccinat and alcohols: 2, 4, 6-trichlorophenol.

**BEFORE YOU START PLEASE READ INSTRUCTIONS CAREFULLY**

- Check the pack and make sure you have all the items listed in the parts list provided.
- When you are ready to start, make sure you have the right tools at hand (not supplied - see the equipment list on next page).
- Ensure there is plenty of space and a clean dry area for assembly.
- Ensure you have enough time to build the product to ensure the building is water tight.

**LOCATION FOR YOUR GARDEN BUILDING**

A minimum of 600mm should be left around the perimeter of your garden building to allow access for maintenance, annual treatment and to allow air flow around the building.

Where possible you should avoid placing your garden building underneath large trees to prevent the tree causing damage to the building.

**TIMBER**

As with all natural materials, timber can be affected during various weather conditions. For the duration of heavy or extended periods of rain, swelling of the wood panels may occur. Warping of the wood may also occur during excessive dry spells due to an interior moisture loss. Unfortunately, these processes cannot be avoided but can be helped. It is suggested that the outdoor building is sprayed with water during extended periods of warm sunshine and sheltered as much as possible during rain or snow.

Once your garden building has been installed it will need to be treated within 14 days (weather permitting) and annually to prevent the timber from deteriorating and to waterproof it. This is required to maintain the anti-rot guarantee.

Dip Treated buildings - Require a preservative treatment to protect against rot and decay and a waterproof treatment to prevent water ingress

Pressure Treated buildings - Require a waterproof treatment to prevent water ingress

Log Cabins/Insulated Garden Rooms - Are supplied untreated and require a preservative and waterproofing treatment.

**BUILDING A BASE**

When thinking about where the building and where the base is going to be constructed: Ensure that there will be access to all sides for maintenance work and annual treatment.

Ensure the base is level and is built on firm ground, to prevent distortion. Refer to diagrams for the base dimensions, The base should be slightly smaller than the external measurement of the building, i.e. The cladding should overlap the base, creating a run off for water. It is also recommended that the floor be at least 25mm above the surrounding ground level to avoid flooding.

**TYPES OF BASE**

- Concrete 75mm laid on top of 75mm hard-core.
- Slabs laid on 50mm of sharp sand.
- Wooden base.

Whilst all products manufactured are made to the highest standards of safety and in the case of children's products independently tested to EN71 level, we cannot accept responsibility for your safety whilst erecting or using this product.

**REGISTER FOR YOUR ANTI-ROT GUARANTEE TODAY**

PLEASE SCAN HERE:

In all instances for assistance with your product, please contact us via our customer portal: <https://www.mgplogistics.co.uk/>.

Mercia Garden Products Limited,  
 Sutton On Trent,  
 Newark,  
 Nottinghamshire,  
 NG23 6QN

## TO DO LIST

- Find a suitable location to build *(see front cover for further information).*
- Build a base *(see front cover for further information).*
- Check the base is flat, level, clear of debris and has 60cm clearance on all sides.
- Check you have the required equipment.
- Check you have all the product items listed *(if you have missing or damaged parts please contact the customer services department, see front cover for contact details).*
- Install the product as per the step by step instructions within this pack.
- Prepare the product ready for treatment.
- Apply a preserving and a waterproofing treatment within 14 days *(weather permitting)* of installation *(pressure treated products do not require a preserver).*
- Register for your anti rot guarantee *(scan the QR below).*
- Tidy the build area and dispose of any remaining parts responsibly.
- Maintain your building *(see the manufacturers recommendations at the back of this pack).*

## EQUIPMENT LIST

- Hammer
- Flat Head Screwdriver
- Drill
- Drill Bit Set
- Phillips and Slotted Bit Sets
- Tape Measure
- Hand Saw
- Spirit Level
- Ladders/Steps
- Stanley Knife/Cutting Tool
- Sand Paper
- Gloves
- Silicone (For Windows Only)
- Wood Filler (Optional)
- Timber Preservative Treatment *(not pressure treated products)*
- Timber Water Proofing Treatment
- Treatment Mixing Stick
- Paint Brush/Sprayer/Roller

## NEED EXTRA SUPPORT

If you are unsure that your base preparation will be suitable, please contact us on 01636 821215 to discuss this further.

Alternatively, you can visit our website or MGP Logistics Online Portal for some further shededucation.

### Website:

<https://www.merciagardenproducts.co.uk/sheducation>

### MGP Logistics Online Portal:

<https://www.mgplogistics.co.uk/>

Here you will find plenty of useful information that'll help with most pre-installation and maintenance queries.

PLEASE SCAN HERE:



## ANY QUESTIONS?

Scan the QR code to contact us via our customer portal.

## NOTES

## ACCESSING VIDEO GUIDES...

Some steps within this set of instructions come with an added video guide for your convenience. These can be accessed via the QR code and used to aid you in constructing that step. See below for how to use.

You can also find all the videos on our youtube channel:  
<https://www.youtube.com/@merciagardenproducts8716/videos>

### 1. Find the QR code within the instruction step...

#### Step.....

Parts Needed- No. QTY 1  
No. QTY 1  
No. QTY 1



Within the instruction step, there will be an icon in the top right that has a QR code in. This is where the video can be accessed from.

*Please note: not every step has a video guide.*

### 2. Open camera app...

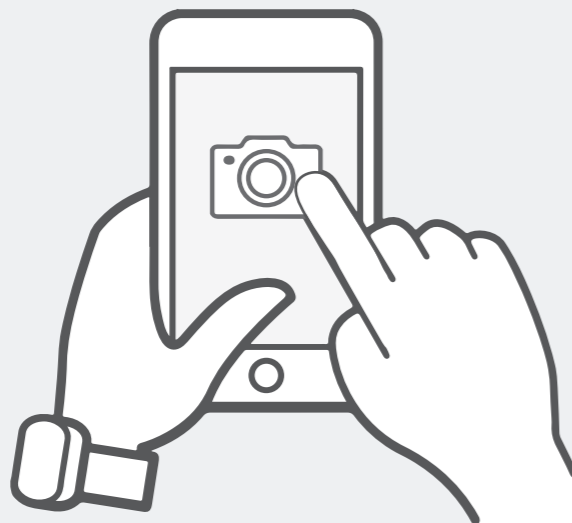

On your personal smart device (phone, tablet etc), open your camera app or QR code scanner app.

## ACCESSING VIDEO GUIDES...

### 3. Scan QR code...



To scan the QR code, hold the camera over the QR code so that it can be seen on the screen. Once the QR code has been registered, follow the prompts on your device to open the video. (This will vary depending on your device.)

*Please note: Ensure to use the back camera of your smart device as this will scan the QR code more accurately.*

### 4. Watch the video...



The video guide will now be displayed on your smart device.

**Disclaimer:** The garden building constructed in the video guides may be constructed differently to your building. Please ensure to read your instructions carefully to avoid error.

Before assembly  
please make sure you have a  
suitable base ready to erect your  
building

**MADE IN GREAT BRITAIN**

**Overall Dimensions:** Width = 2056mm  
Depth = 2458mm  
Height = 2054mm

**Base Dimensions:** Width = 1888mm  
Depth = 2386mm

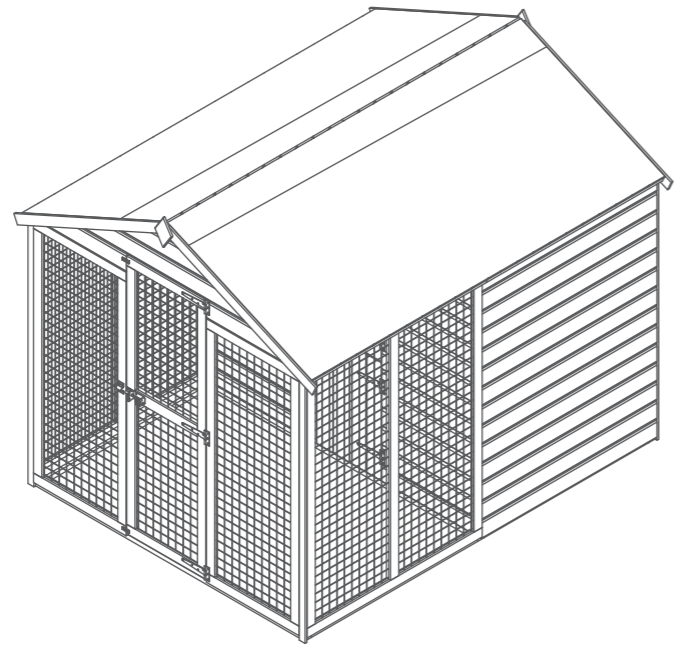

**8x6 Building Contents:**  
10DTSHAX0806-V1

- 1

**Door Panel QTY 1**  
AI-10S11SHAGSD1808X1959-V1
- 2

**Side Panel QTY 2**  
AI-S11SHPP1193X1571-V1
- 3

**Plain Panel QTY 1**  
AI-10S11SHAGP1808X1972-V1
- 4

**Large Mesh Panel QTY 2**  
AI-10S11MESDP1193X1560-V1
- 5

**Mesh Door QTY 1**  
AI-10S11MESLFD538X1639-V1
- 6

**Small Mesh Panel QTY 2**  
AI-10S11MESSP630X1560-V1
- 7

**Door A QTY 1**  
AI-S11FMBMZBD542X965-V1
- 8

**Door B QTY 1**  
AI-S11FMBMZBD542X695-V1

- 9

**Floor QTY 3**  
AI-S21MBF599X1122-V1
- 10

**Gable Top QTY 1**  
AI-S11SHASDGT1808X402-V1
- 11

**Roof Panel QTY 4**  
AI-S11MBAR1205X1075-V1
- 12

**Fascias - 12x60x1100mm QTY 4**  
S1260-1100mm
- 13

**Bearer - 27x44x1119mm QTY 2**  
F2744-1119mm
- 14

**Bearer - 27x44x1860mm QTY 3**  
F2744-1860mm
- 15

**Bearer - 27x44x1135mm QTY 2**  
F2744-1135mm
- 16

**Ridge Bar - 27x44x1153mm QTY 1**  
F2744-1153mm
- 17

**Ridge Bar - 27x44x1137mm QTY 1**  
F2744-1137mm
- 18

**Cover Trim - 12x40x1582mm QTY 4**  
S1240-1582mm
- 19

**Support Framing - 28x28x949mm QTY 2**  
FS2828-949mm
- 20

**Door Strip - 12x27x1615mm QTY 1**  
S1227-1615mm
- 21

**6" T-Hinge QTY 7**  
PI-07-0082
- 22

**L Bracket QTY 4**  
PI-07-0012
- 23

**Turn Button QTY 6**  
PI-07-0034
- 24

**Ply Triangle QTY 2**
- 25

**Pad Bolt QTY 1**  
PI-07-0035
- 26

**U Shaped Channel QTY 2**  
PI-07-0013
- 27

**Finial QTY 2**  
Shed Diamond
- 28

**Felt**
- 29

**Capping Felt**

### 10x6 Building.

10DTSHAX0806-V1 + 10DTSHAX0206PB-V1

#### Overall Dimensions:

Width = 2056mm  
Depth = 2458mm  
Height = 2054mm

#### Base Dimensions:

Width = 1888mm  
Depth = 2386mm

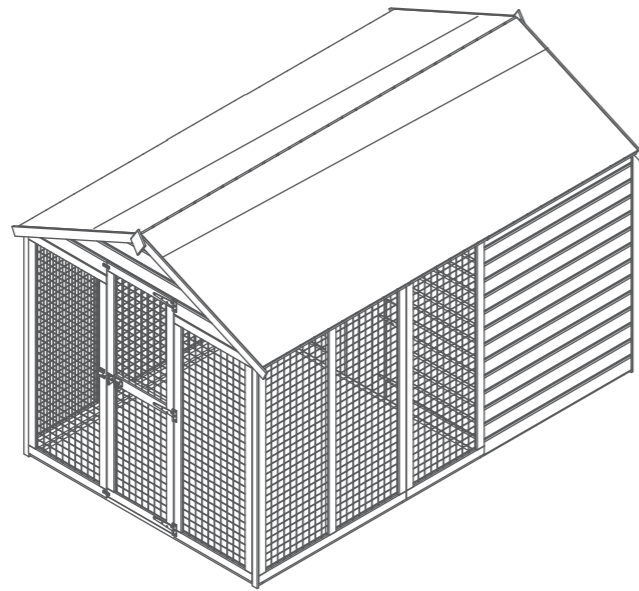

### 2x6 Pack B Contents:

10DTSHAX0206PB-V1

30

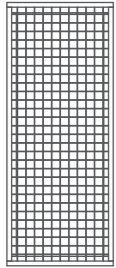

**Small Mesh Panel QTY 2**  
AI-10S11MESSP630X1560-V1

31

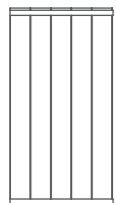

**Roof Panel QTY 2**  
AI-S11MBAR630X1075-V1

32

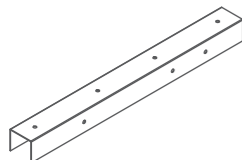

**U Shaped Channel QTY 3**  
PI-07-0013

33



**Bearer - 27x44x630mm QTY 3**  
F2744-630mm

34



**Truss support - 27x44x958mm QTY 2**  
F2744-G-978mm (958mm finished length, 1 x angled cut)

35



**Truss Block - 27x44x140mm QTY 2**  
F2744-G-160mm (140mm finished length, 1 x angled cut)







36



**Truss Brace - 27x44x450mm QTY 1**  
F2744-G-450mm (450mm finished length, 2 x angled cuts)

### Nail Bags

There may be extra screws present in the nail bag

-  **70mm screws x 32**
-  **50mm screws x 76**
-  **40mm screws x 62**
-  **30mm screws x 141**
-  **30mm Black Screw x 6**
-  **Felt Tacks x 150**

### Pre Assembly

Before assembling, remove the transportation blocks from the bottom of each panel.

Take care removing the blocks as to not damage the panels. Tap with a flat headed screwdriver and hammer.

Dispose of the blocks once removed.

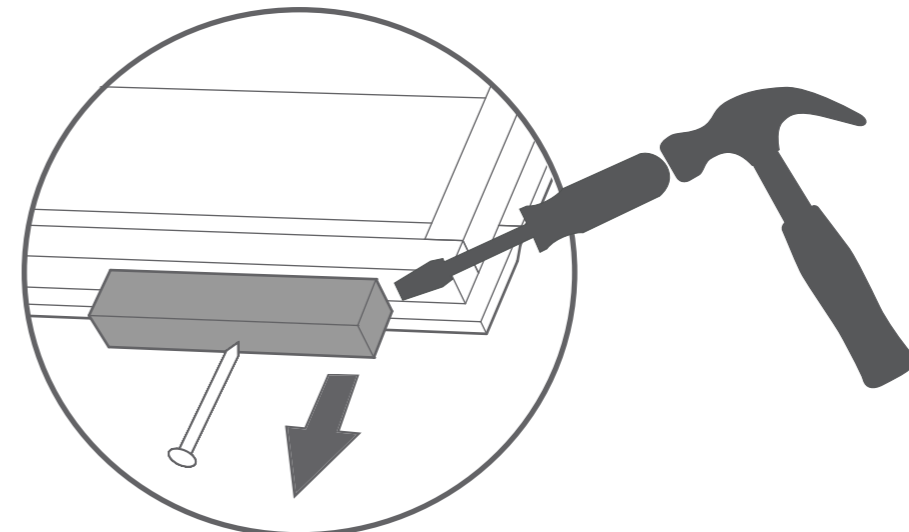

**\*If you have purchased a 2ft extension pack B, please follow steps for 'Extension Pack B' where relevant.\***

**Step 1**  
Parts Needed - No. 13 QTY 2  
No. 14 QTY 2

Position the bearers (No. 13 & 14) on your base as shown, ensure bearers No.13 sits inside bearers No.14.

Fix the framing together with 2x70mm screws per corner.

Ensure to construct your bearers on a firm and level base, that has suitable drainage free from areas where standing water can collect. (See front page on base requirements).

8x70mm screws.

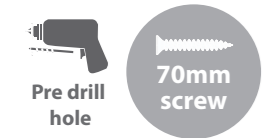

**IMPORTANT: Pre-drill before fixing screws.**

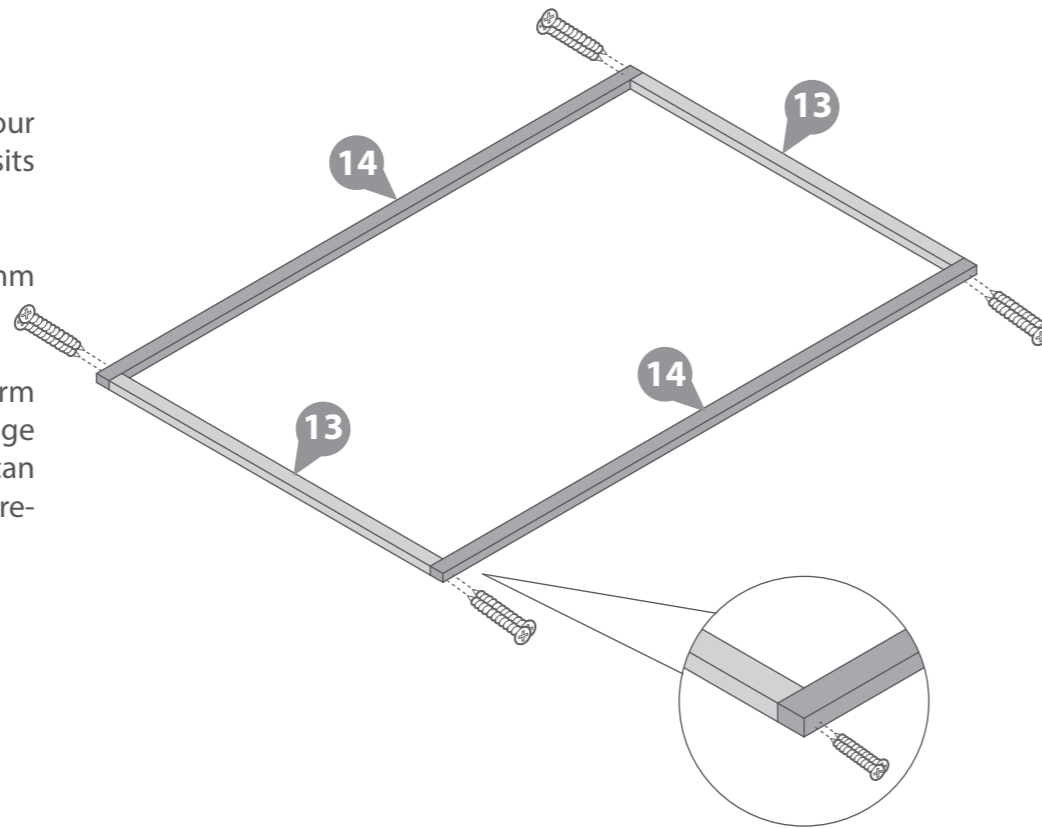

**Step 3**  
Parts Needed - No. 2 QTY 1

Place the second Side Panel (No. 2) onto the bearers and fix to the Plain Gable with 3x50mm screws.

**\*\*Do NOT fix to the bearers until the Roof is secured\*\***

3x50mm screws.

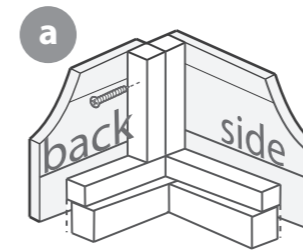

**IMPORTANT: Pre-drill before fixing screws.**

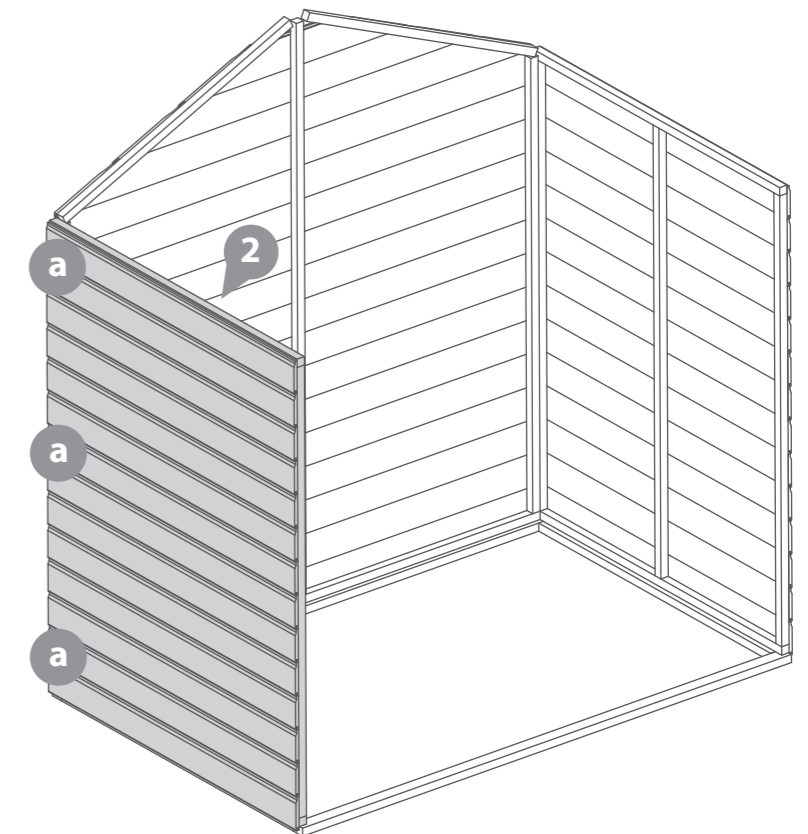

**Step 2**  
Parts Needed - No. 3 QTY 1  
No. 2 QTY 1

Place the Side Panel (No. 2) and the Plain Panel (No. 3) onto the bearers and fix together at the corner with 3x50mm screws.

**\*\*Do NOT fix to the bearers until the Roof is secured\*\***

3x50mm screws.



**IMPORTANT: Pre-drill before fixing screws.**

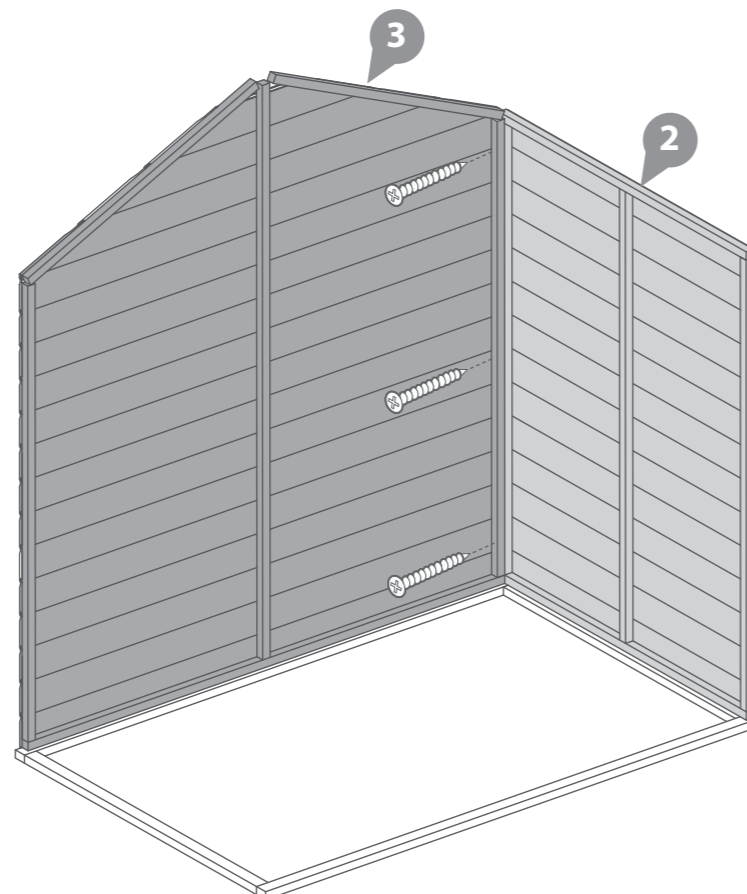

**Step 4**  
Parts Needed - No. 1 QTY 1

Place the Door Panel (No. 1) onto the bearers. Fix the Door Panel (No. 1) to the side panels with 3x50mm screws per side.

**\*\*Do NOT fix to the bearers until the Roof is secured\*\***

6x50mm screws.

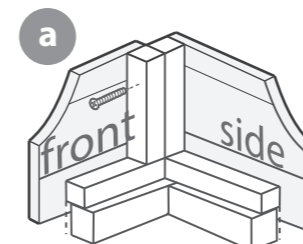
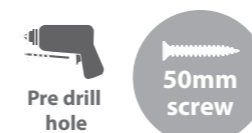

**IMPORTANT: Pre-drill before fixing screws.**

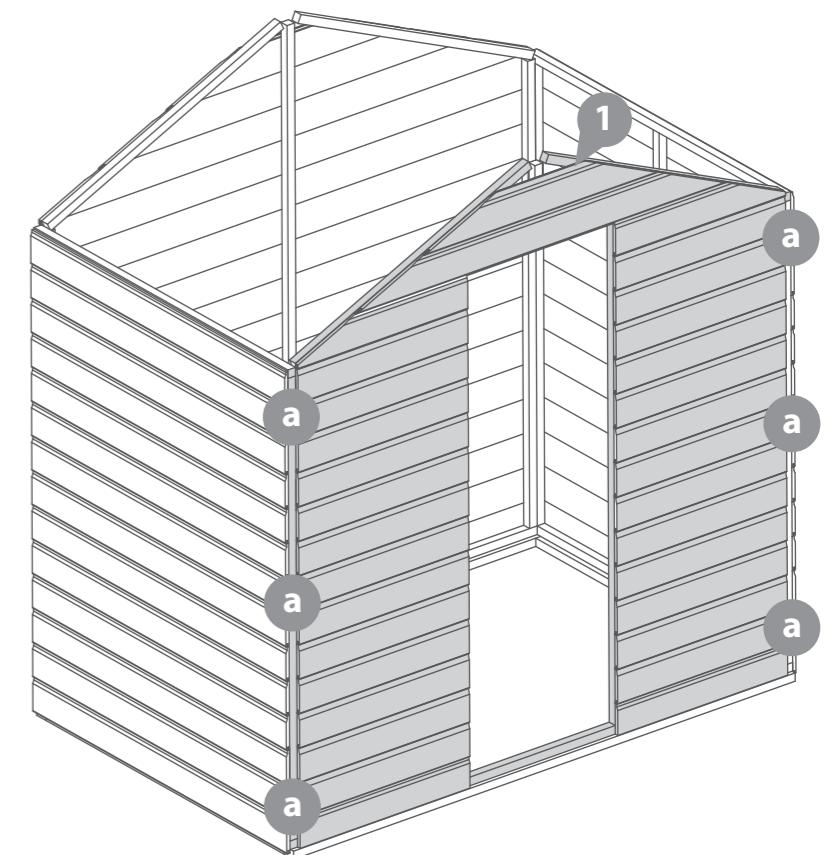

**Step 5**  
**Parts Needed - No. 14 QTY 1**  
**No. 15 QTY 2**

Place the remaining bearers (**No.14 & 15**) into position as shown and secure to each with 2x70mm screws per corner.

*\*The Run bearers do not fix to the Kennel area\**

**4x70mm screws.**

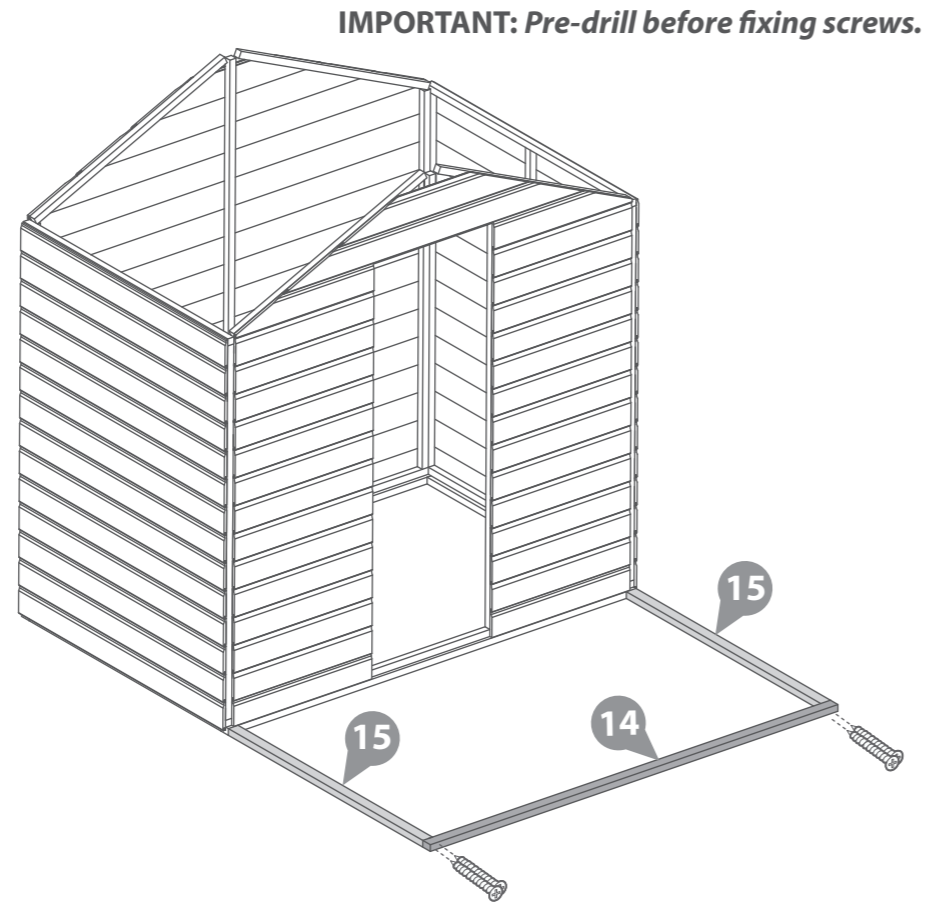

**Step 5b - EXTENSION PACK B**  
**Parts Needed - No. 30 QTY 2**

Locate the Small Mesh Panels (**No. 30**) on top of the front bearers.

Fix to the adjacent panel using 3x50mm screws per panel.

**\*\*Do NOT fix to the bearers until the Roof is secured\*\***

**6x50mm screws.**

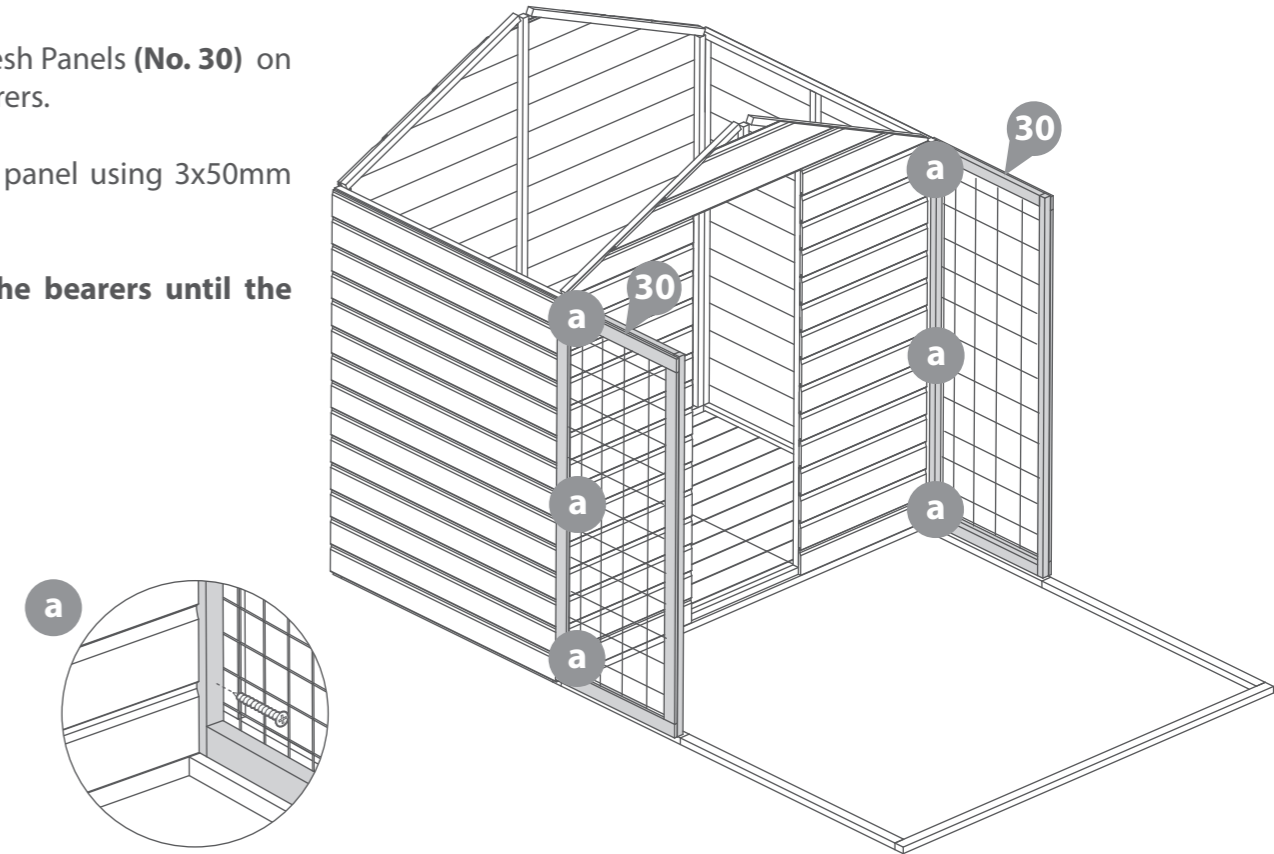

**Step 5a - EXTENSION PACK B**  
**Parts Needed - No. 14 QTY 1**  
**No. 15 QTY 2**  
**No. 33 QTY 2**

Place the remaining bearers (**No.14 & 15 & 33**) into position as shown and secure to each with 2x70mm screws per corner.

Secure the adjacent bearers together using 2x70mm screws per join. Screw at an angle through to the next bearer.

*\*The Run bearers do not fix to the Kennel area\**

**8x70mm screws.**

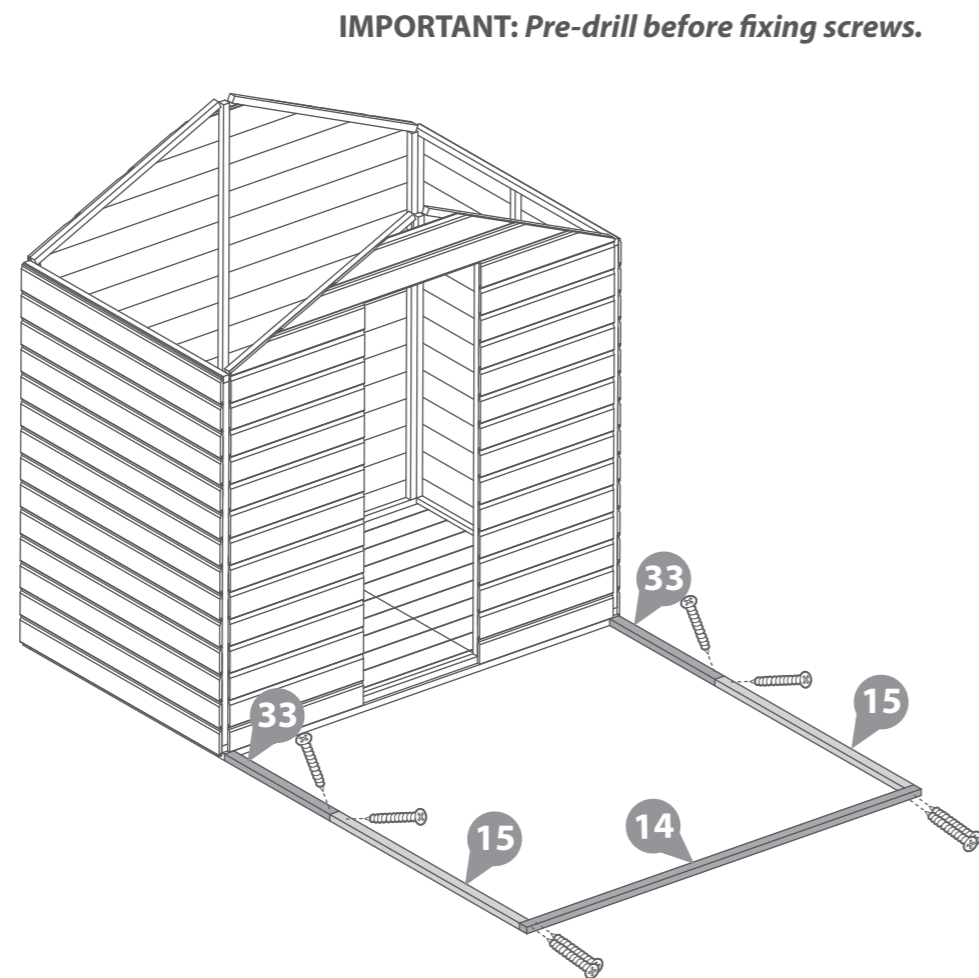

**Step 6**  
**Parts Needed - No. 4 QTY 2**

Locate both Large Mesh Panel (**No. 4**) onto the front bearers as shown.

Fix the panels into the adjacent panels with 3x50mm screws per panel.

**\*\*Do NOT fix to the bearers until the Roof is secured\*\***

6x50mm screws.

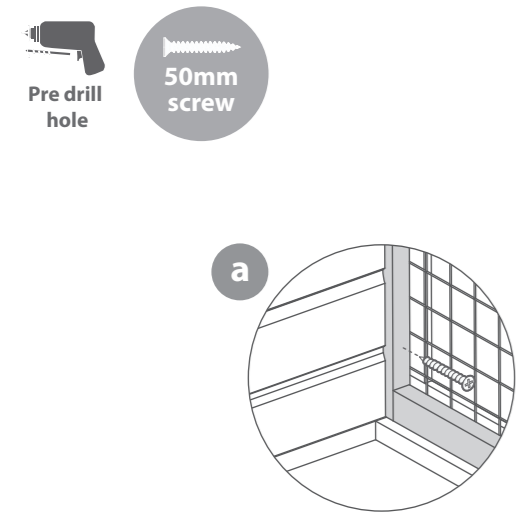

**IMPORTANT: Pre-drill before fixing screws.**

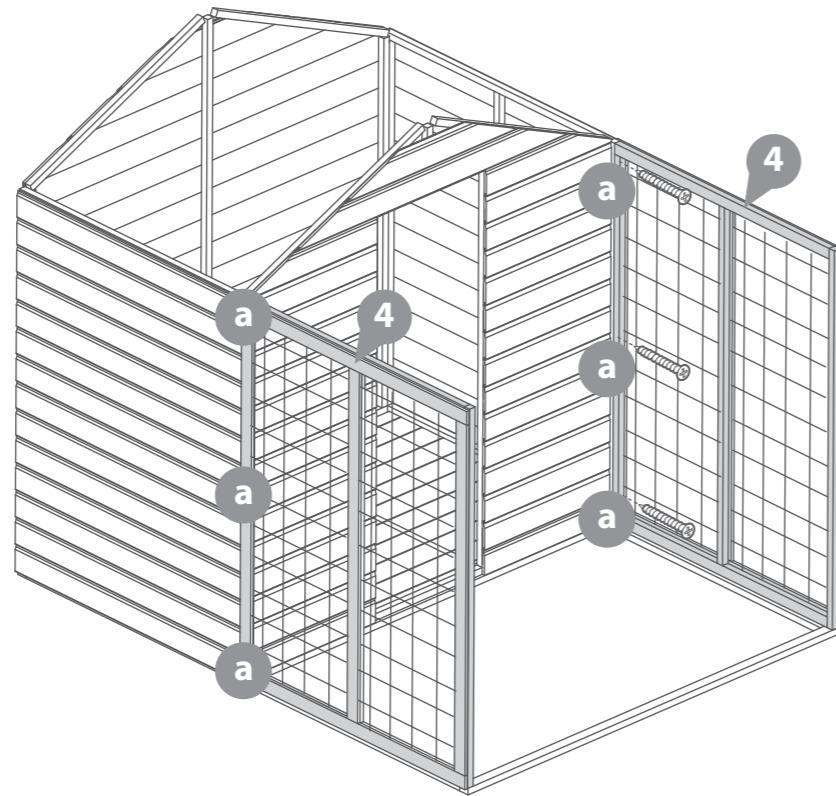

**Step 7**  
**Parts Needed - No. 6 QTY 2**

Locate both Small Mesh Panels (**No. 6**) onto the front bearers as shown.

Fix to the Large Mesh Panels with 3x50mm screws per panel, making sure you screw from the inside.

**\*\*Do NOT fix to the bearers until the Roof is secured\*\***

6x50mm screws.

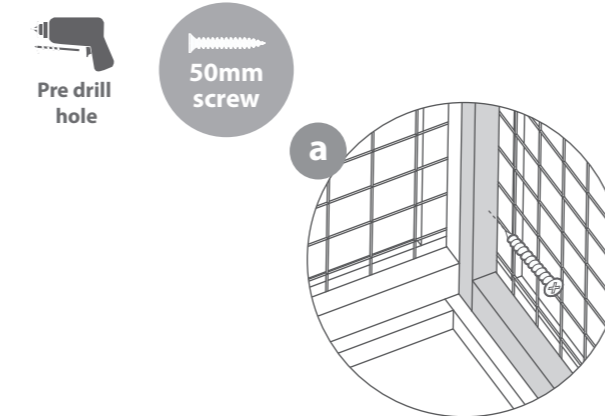

**IMPORTANT: Pre-drill before fixing screws.**

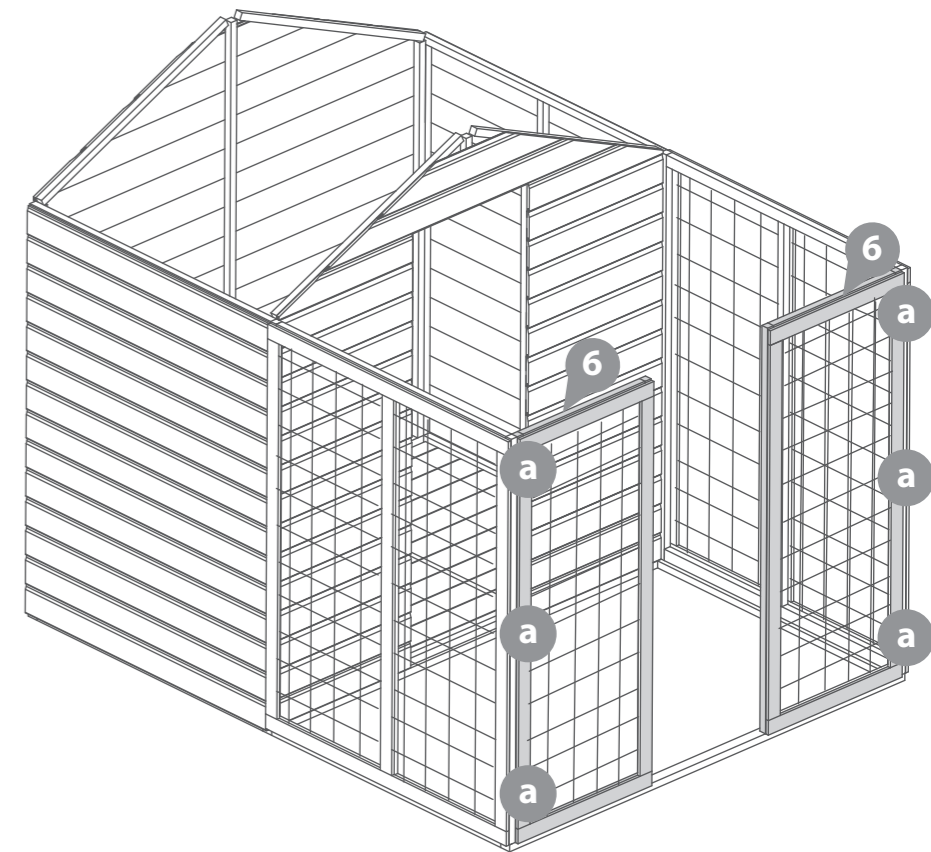

**10X6 EXTENSION PACK B**

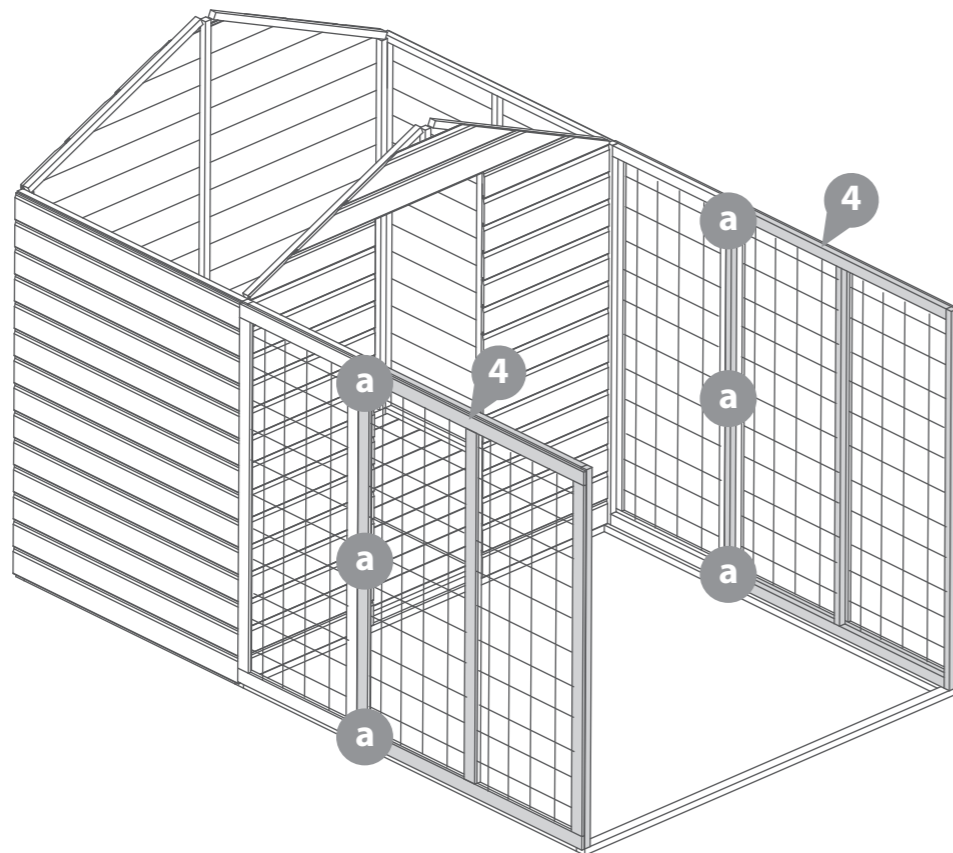

**10X6 EXTENSION PACK B**

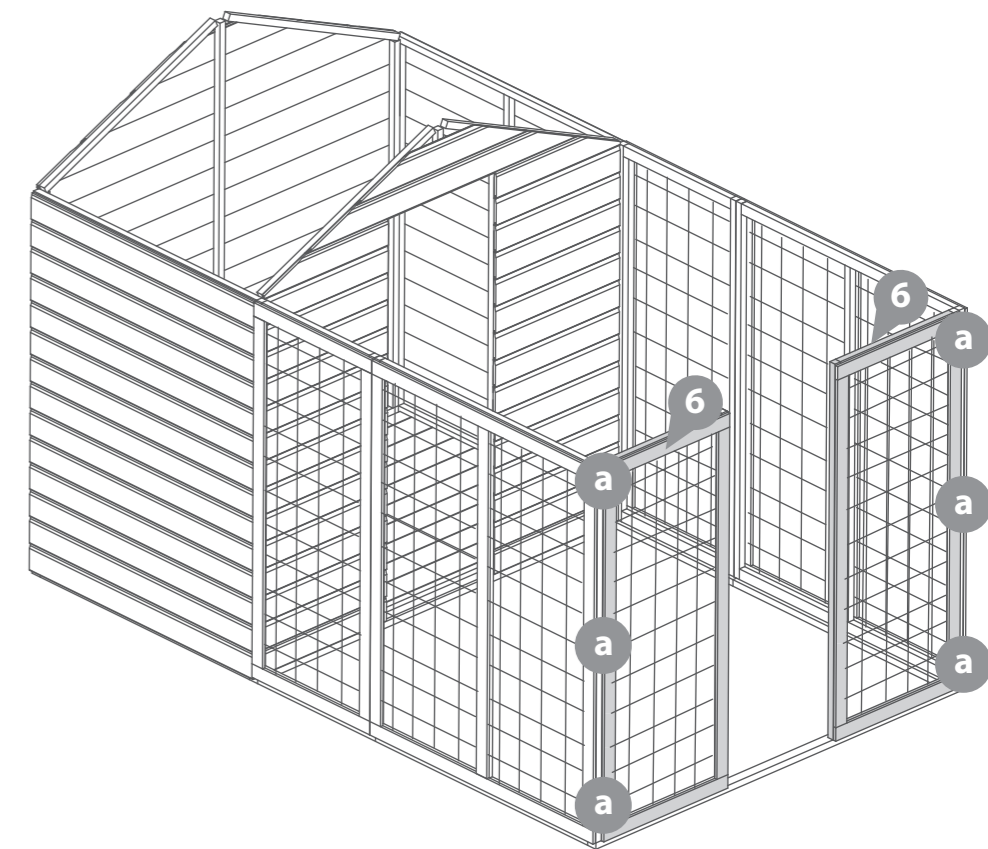



**Step 8**  
**Parts Needed - No. 10 QTY 1**

Locate the Gable Top (**No. 10**) on top of the two Small Mesh Panels (**No. 6**), as shown.

Secure in place using 4x50mm screws per panel.

**4x50mm screws**

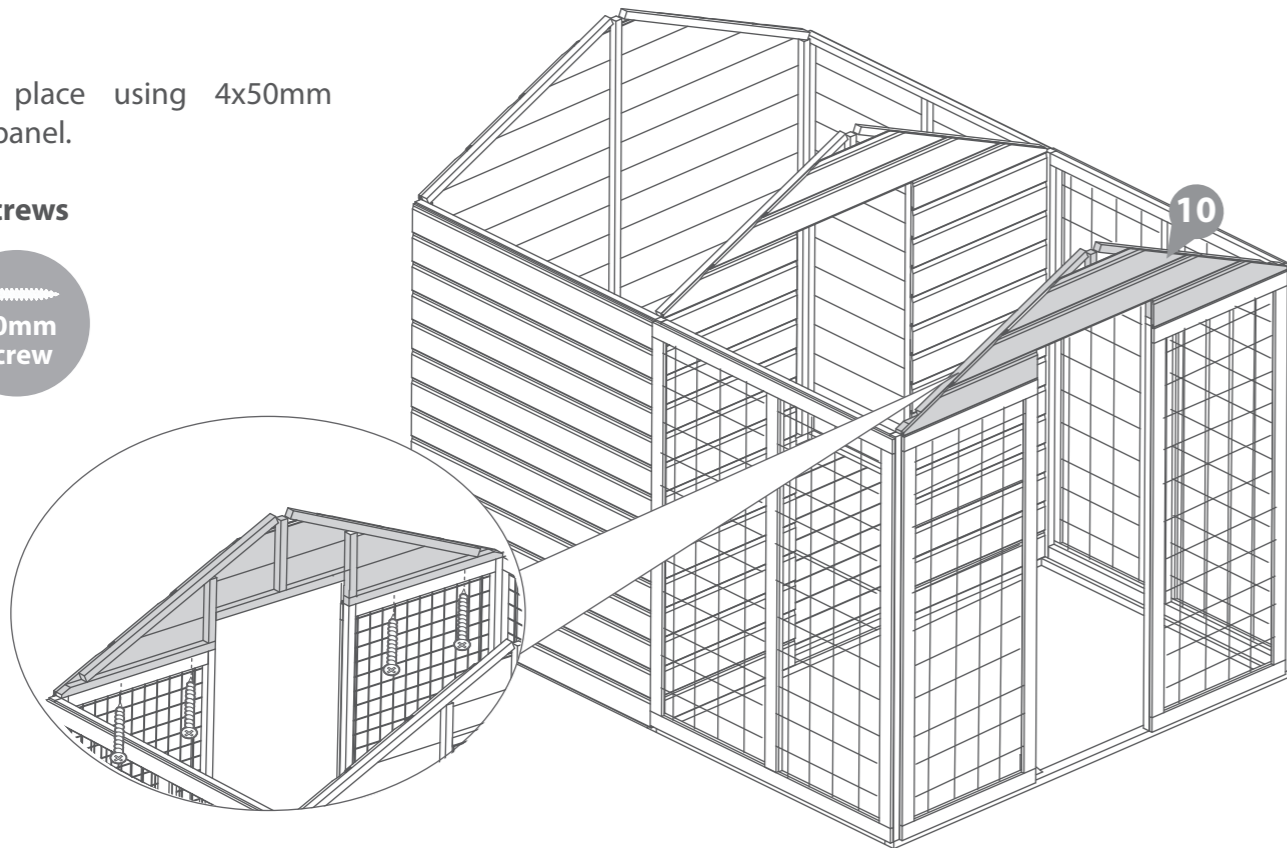
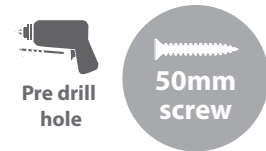

**IMPORTANT: Pre-drill before fixing screws.**

**Step 9**  
**Parts Needed - No. 24 QTY 2**

Locate the Ply Triangles (**No. 24**) to the top and bottom of the door way, as shown.

Fix in place using 2x40mm screws per triangle.

**4x40mm screws**

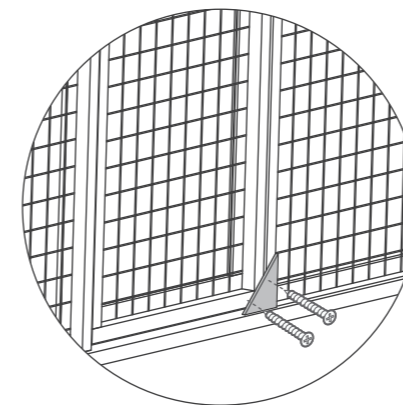

**IMPORTANT: Pre-drill before fixing screws.**

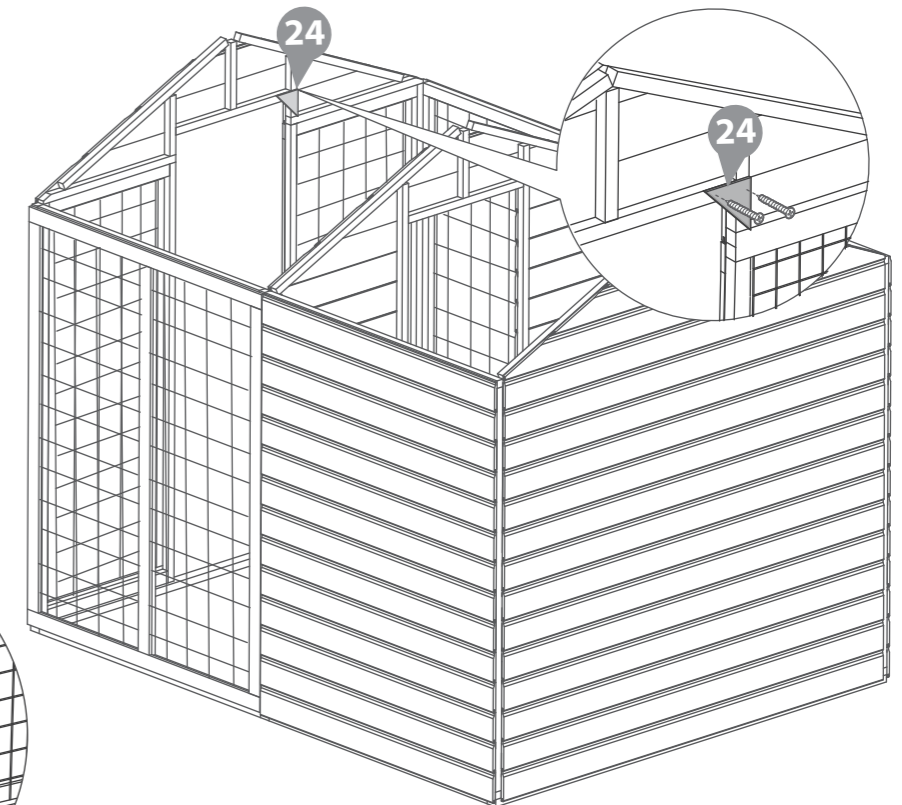

**10X6 EXTENSION PACK B**

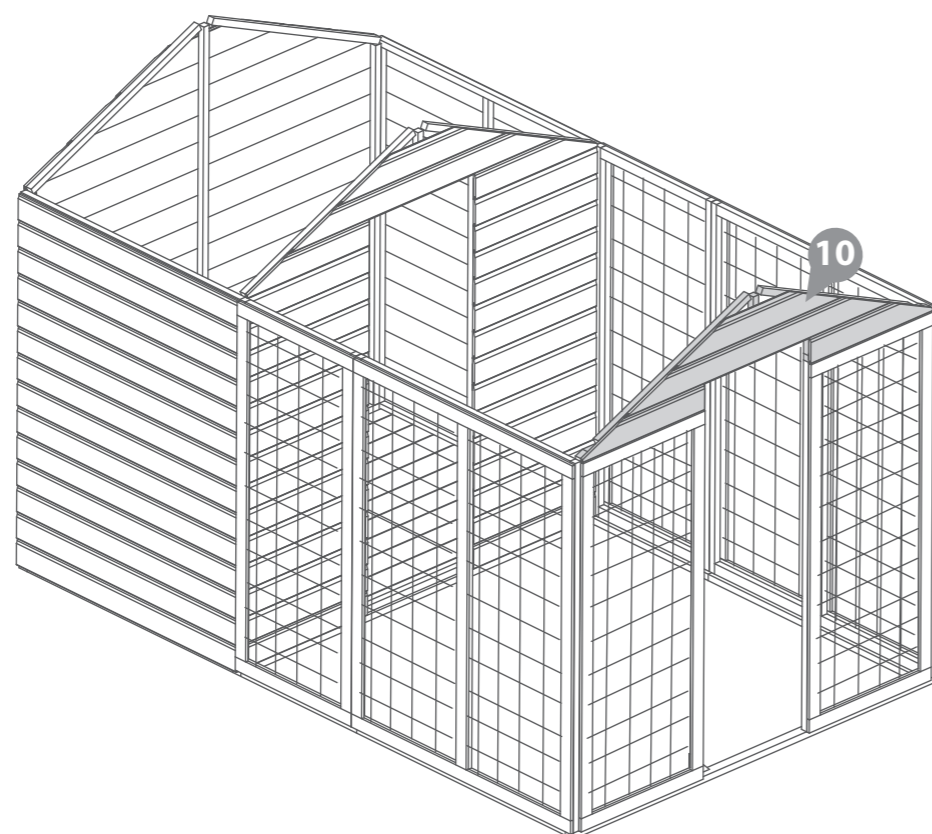

**10X6 EXTENSION PACK B**

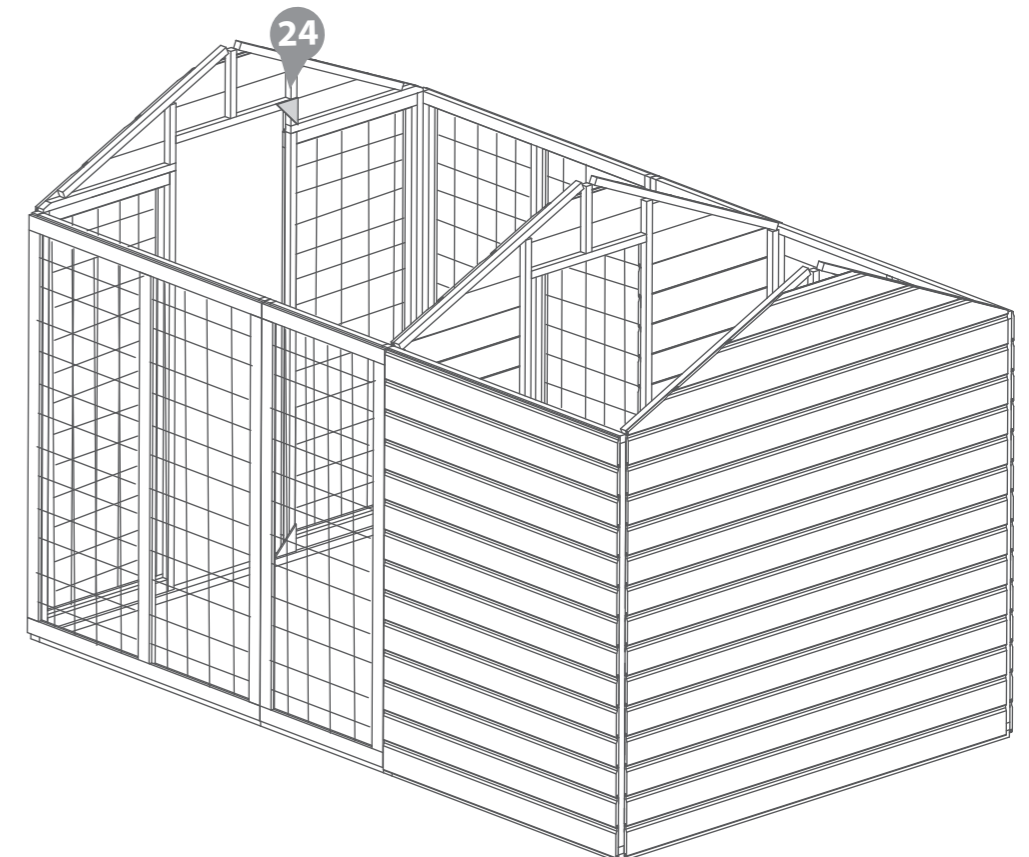

**Step 10**

- Parts Needed - No. 16 QTY 1**  
**No. 17 QTY 1**  
**No. 22 QTY 4**

Inside the Kennel part of the building, locate the Ridge Bar (**No.17**) in between the Plain Panel and the Door Panel, in line with the central framing of the gables.

Fix the Ridge Bar (**No.17**) in place using one L-bracket (**No.22**) per end. Secure with 4x30mm screws per bracket.

In the Run part of the building, locate the Ridge Bar (**No.16**) in between the Door Panel and the Gable Top, in line with the central framing of the gables.

Fix the Ridge Bar (**No.16**) in place using one L-bracket (**No.22**) per end. Secure with 4x30mm screws per bracket.

**16x30mm screws**



Pre drill hole



30mm screw

**IMPORTANT: Pre-drill before fixing screws.**

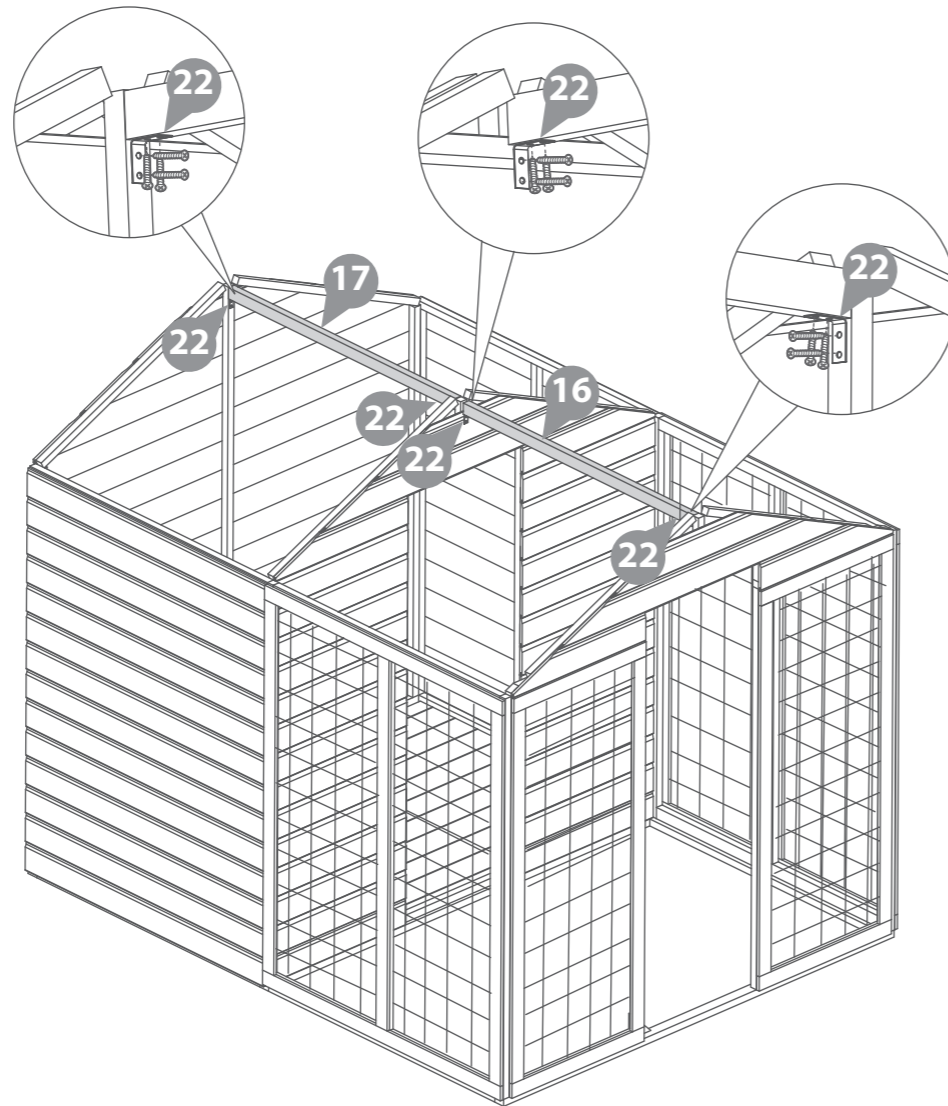

**Step 10a - EXTENSION PACK B**

- Parts Needed - No. 16 QTY 1**  
**No. 17 QTY 1**  
**No. 22 QTY 4**  
**No. 32 QTY 1**  
**No. 33 QTY 4**

Inside the Kennel part of the building, locate the Ridge Bar (**No.17**) in between the Plain Panel and the Door Panel, in line with the central framing of the gables.

Fix the Ridge Bar (**No.17**) in place using one L-bracket (**No.22**) per end. Secure with 4x30mm screws per bracket.

Secure the Ridge Bars (**No.16 & 33**) together using the U-channel (**No.32**) with 6x30mm screws. Ensure the framing is flush and level.

In the Run part of the building, locate the assembled Ridge Bar (**No.16 & 33**) in between the Door Panel and the Gable Top, in line with the central framing of the gables.

Fix the assembled Ridge Bar in place using one L-bracket (**No.22**) per end. Secure with 4x30mm screws per bracket.

**22x30mm screws**



Pre drill hole



30mm screw

**IMPORTANT: Pre-drill before fixing screws.**

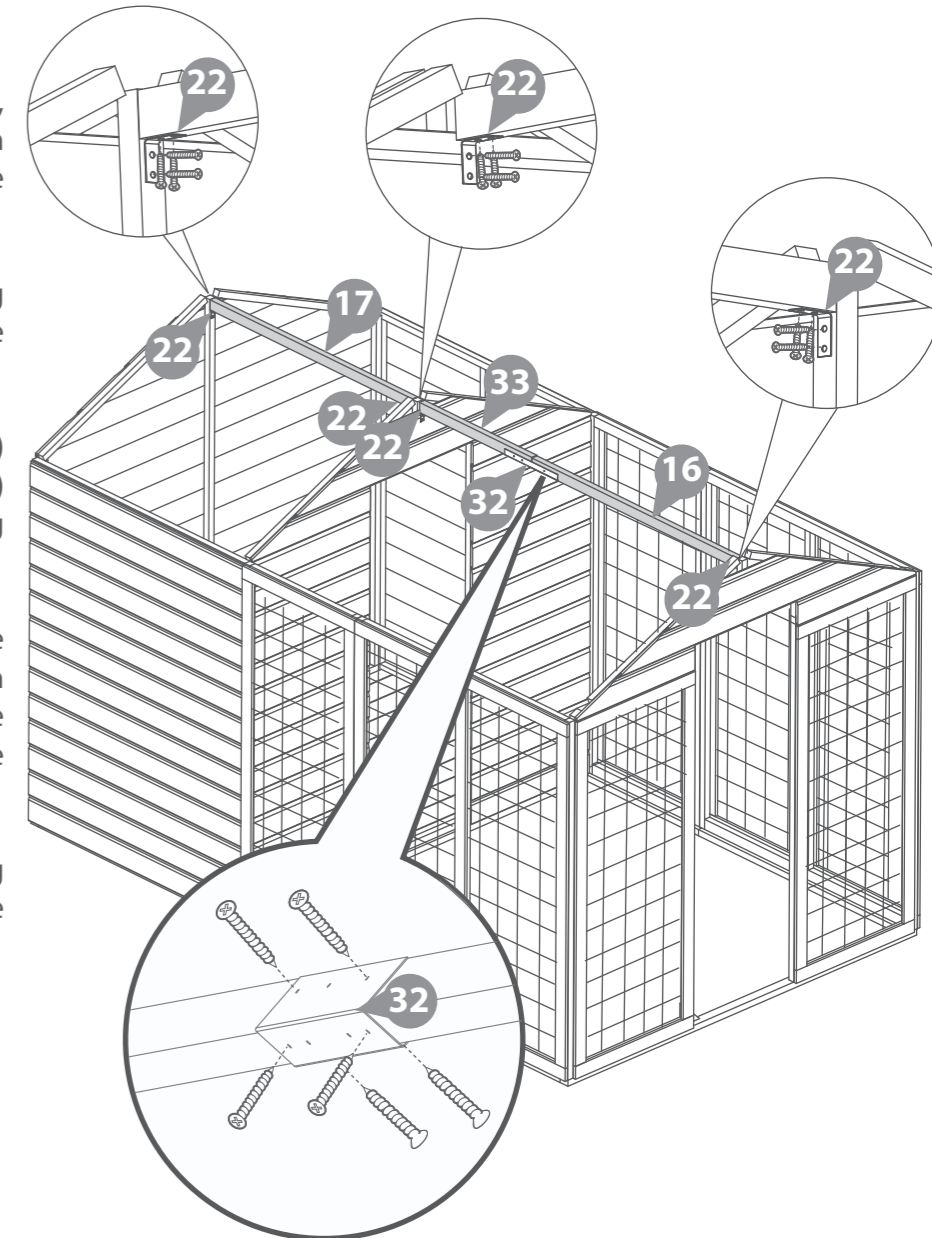

**Step 11**  
Parts Needed - No. 19 QTY 2

Locate the Support Framing (No.19) flush with the front of the Gable Top (No.10)

Secure in place with 3x50mm screws per frame, screwing through the framing into the Gable behind.

6x50mm screws



**IMPORTANT: Pre-drill before fixing screws.**

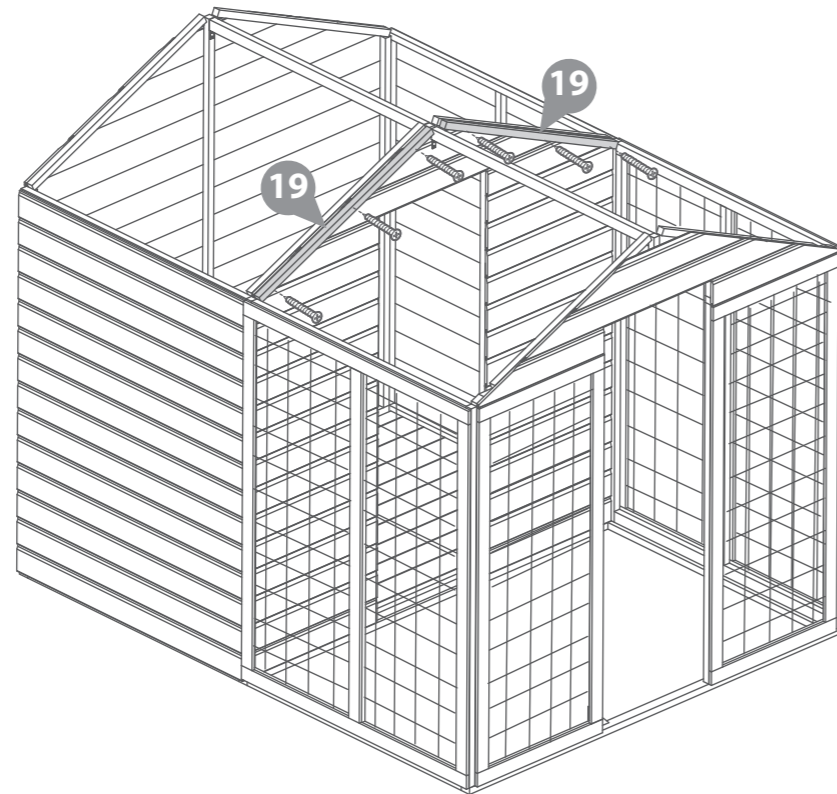

**10X6 EXTENSION PACK B**

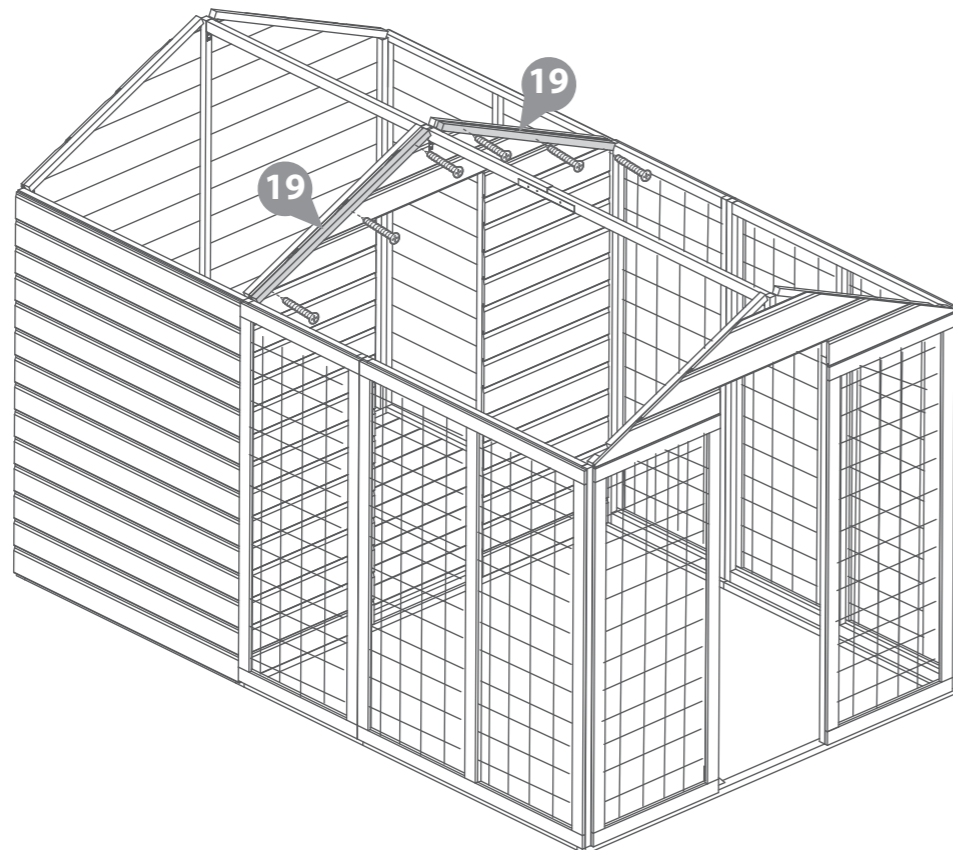

**Step 12**  
Parts Needed - No. 11 QTY 4  
No. 26 QTY 2

- a Place the Roof Panels (No.11) on top of the building, making sure the framing in the roof panels sits firmly within the Gables and on top of the ridge bar.

**\*\*Make sure that you have got the Roof Panels the correct way around, with the recess at the top of the apex, as shown in the diagram.**

Ensure the edges of the Roof Panels are flush with the outer cladding of the Plain Gable and the Gable Top.

- b Once the Roofs have been located on the building, Locate a U-channel (No.26) across the join between the two adjacent Roof Panels framing, as shown.

Ensure the U-channel is spaced over both Roofs framing equally, and secure in place using 6x30mm screws per channel.

Repeat this for both Roofs.

- c From the top, fix directly through the roof panels (No.11) and into the Ridge Bars below using 12x50mm screws.

It is essential that the Ridge Bars and Roof Panel framing pull together when fixed. You may require another person pushing the Ridge Bars up from below to achieve this.

**\*\*Note: Be cautious of the roof panels before they are secured to the building. They may need added support until fixed.**

12x30mm screws.  
12x50mm screws.

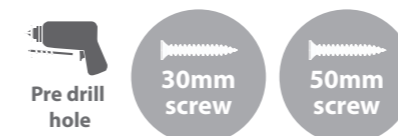

**IMPORTANT: Pre-drill before fixing screws.**

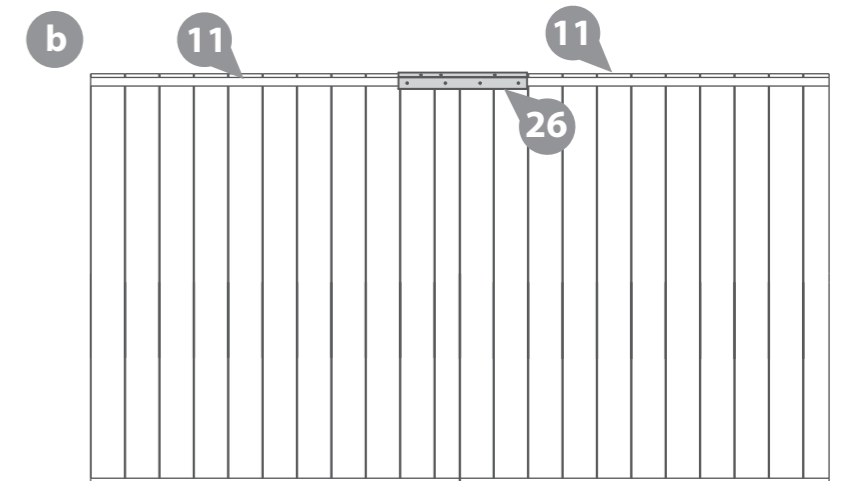
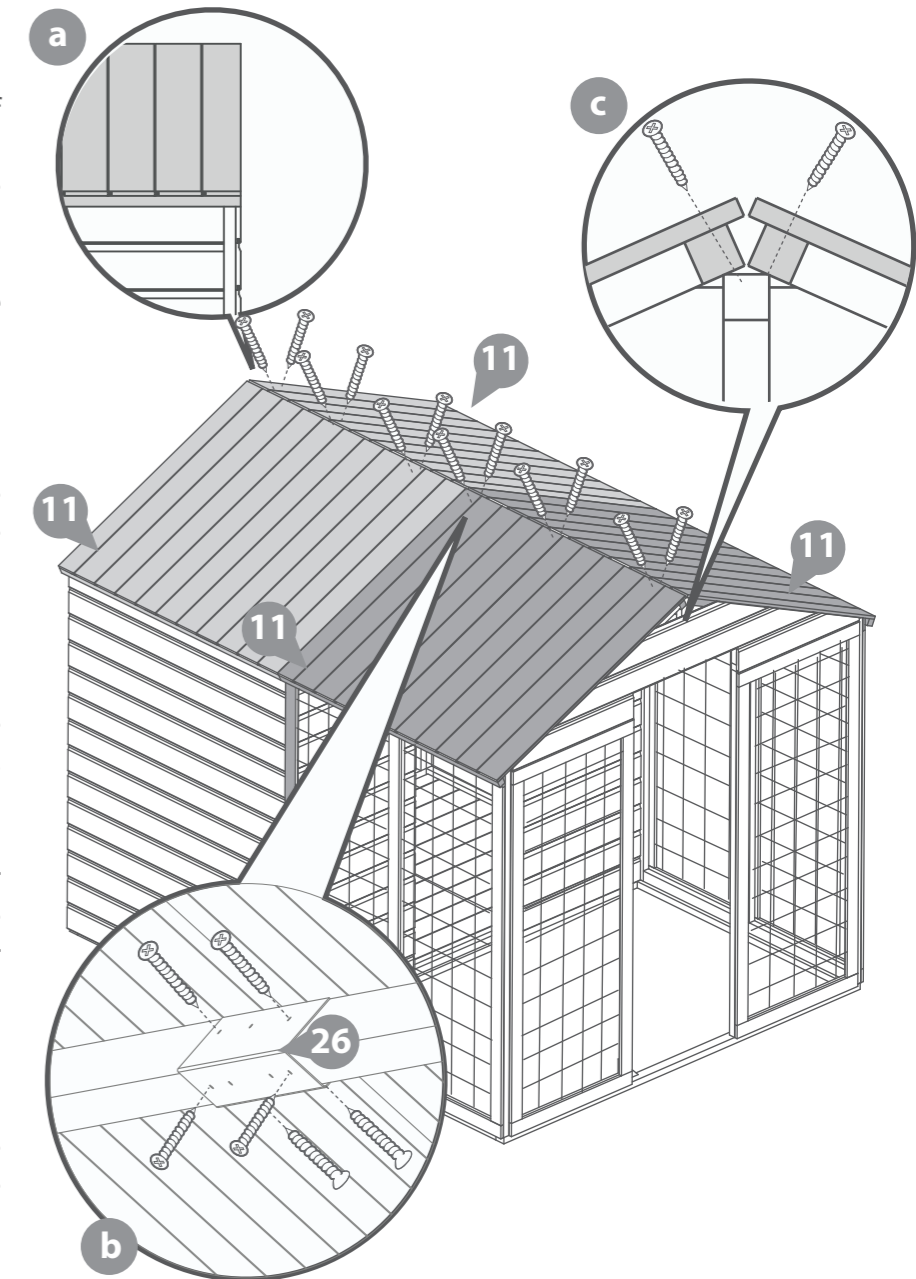

**IMPORTANT: Pre-drill before fixing screws.**

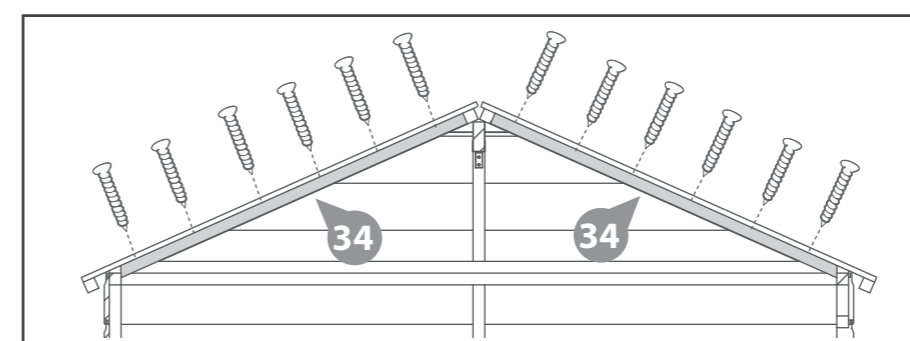
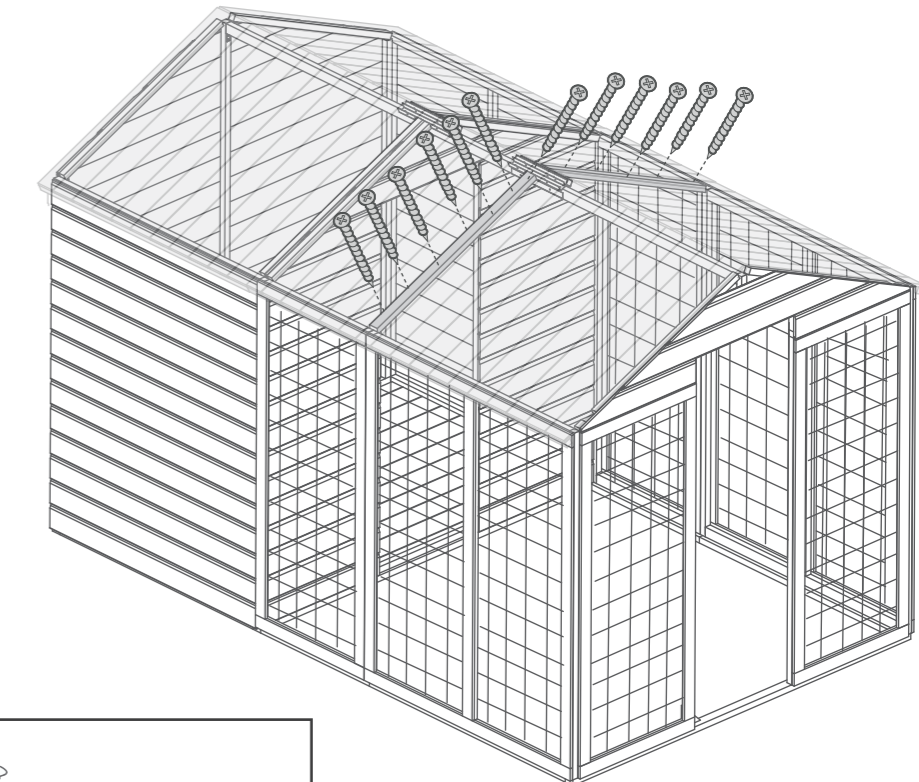
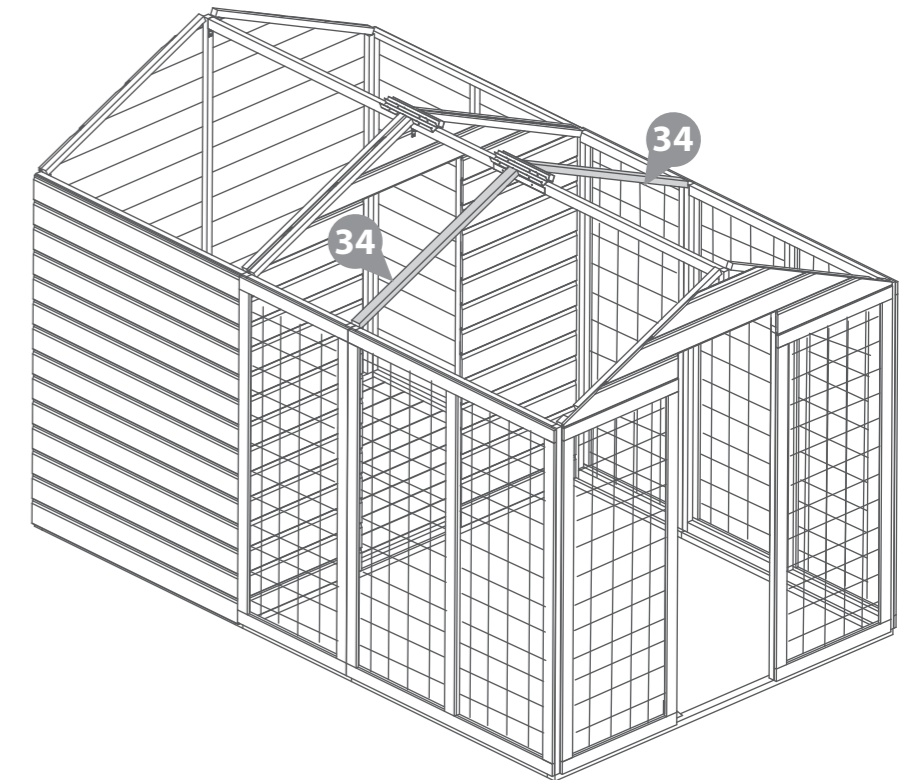

**Step 12b - EXTENSION PACK B**  
**Parts Needed - No. 34 QTY 2**

Position a Truss Support (No.34), centrally underneath the join of the two roofs in the run area internally. Ensure the Truss Support sits flush to the underside of the Roof Panels and flush at the top, as shown.

Fix the Truss Support (No.34) in place using 5x30mm screws, fixing through the roof panels into the truss from the outside of the building. Alternate fixing the screws through each roof panel, as shown.

**12x30mm screws**



**IMPORTANT: Pre-drill before fixing screws.**

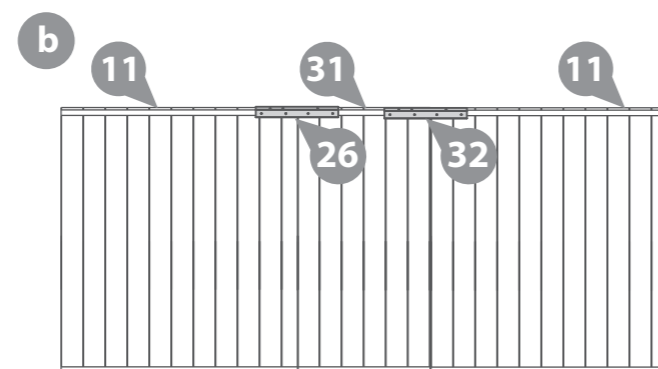
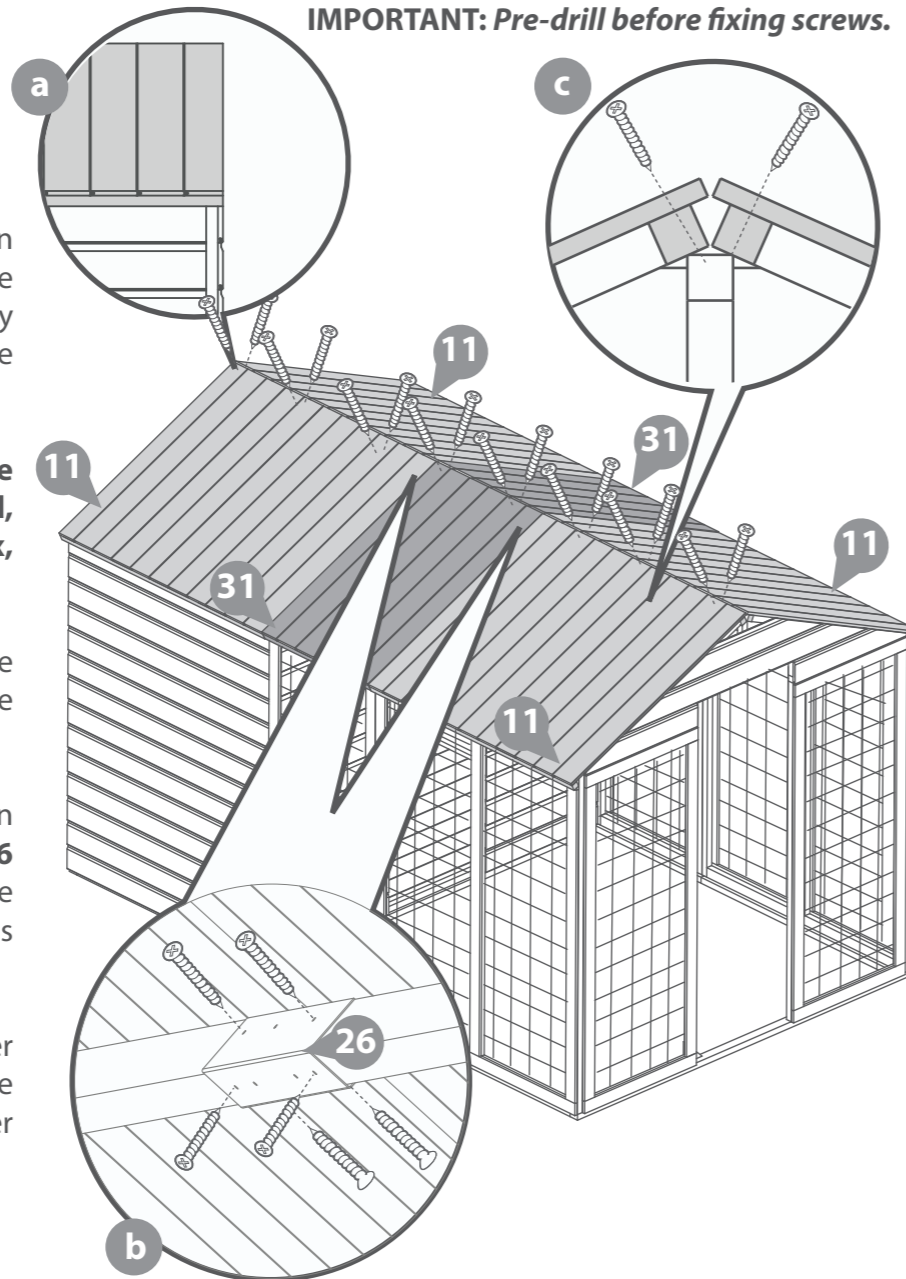

**Step 12a - EXTENSION PACK B**  
**Parts Needed - No. 11 QTY 4**  
**No. 26 QTY 2**  
**No. 31 QTY 2**  
**No. 32 QTY 2**

**a** Place the Roof Panels (No.11 & 31) on top of the building, making sure the framing in the roof panels sits firmly within the Gables and on top of the ridge bar.

**\*\*Make sure that you have got the Roof Panels the correct way around, with the recess at the top of the apex, as shown in the diagram.**

Ensure the edges of the Roof Panels are flush with the outer cladding of the Plain Gable and the Gable Top.

**b** Once the Roofs have been located on the building, locate a U-channel (No.26 & 32) across the joins between the adjacent Roof Panels framing, as shown.

Ensure the U-channels are spaced over the Roofs framing equally, and secure in place using 6x30mm screws per channel.

Repeat this for all Roofs.

**c** From the top, fix directly through the roof panels (No.11 & 31) and into the Ridge Bars below using 16x50mm screws.

It is essential that the Ridge Bars and Roof Panel framing pull together when fixed. You may require another person pushing the Ridge Bars up from below to achieve this.

**\*\*Note: Be cautious of the roof panels before they are secured to the building. They may need added support until fixed.**

**24x30mm screws.**  
**16x50mm screws.**



**Step 12c - EXTENSION PACK B**  
**Parts Needed - No. 35 QTY 2**

Position a Truss Block (No.35), up to the underside of the Truss Support, so that the angled edge is facing upwards, flush to the Truss Support,

Fix in place with 2x50mm screws, through the block into the panel framing.

Repeat for the opposite of the building.

**4x50mm screws**

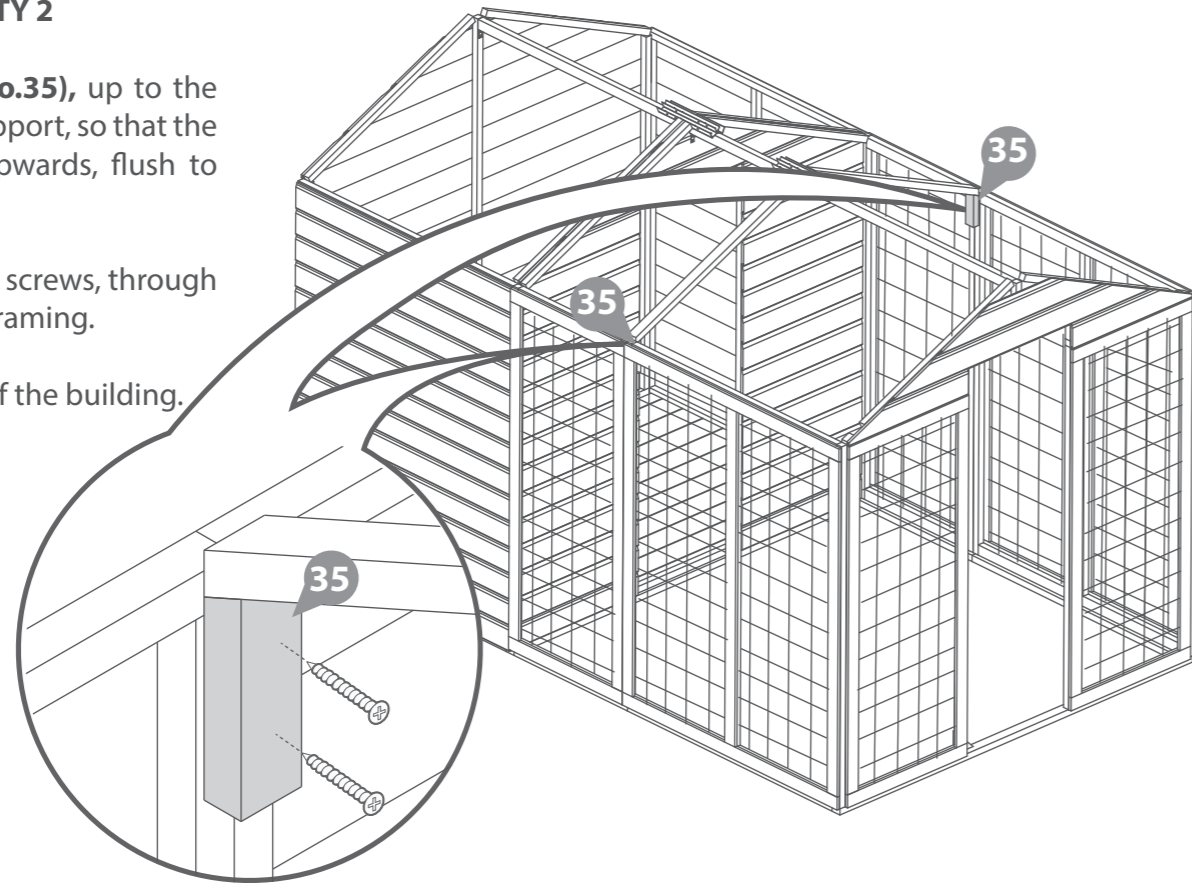
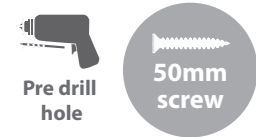

**Step 12d - EXTENSION PACK B**  
**Parts Needed - No. 36 QTY 1**

Position the Truss Brace, (No.36), underneath the two Truss Supports, ensuring they sit flush to one another. The Truss brace should sit horizontally - parallel to the floor.

Fix in place using 2x40mm screws per end.

**4x40mm screws**

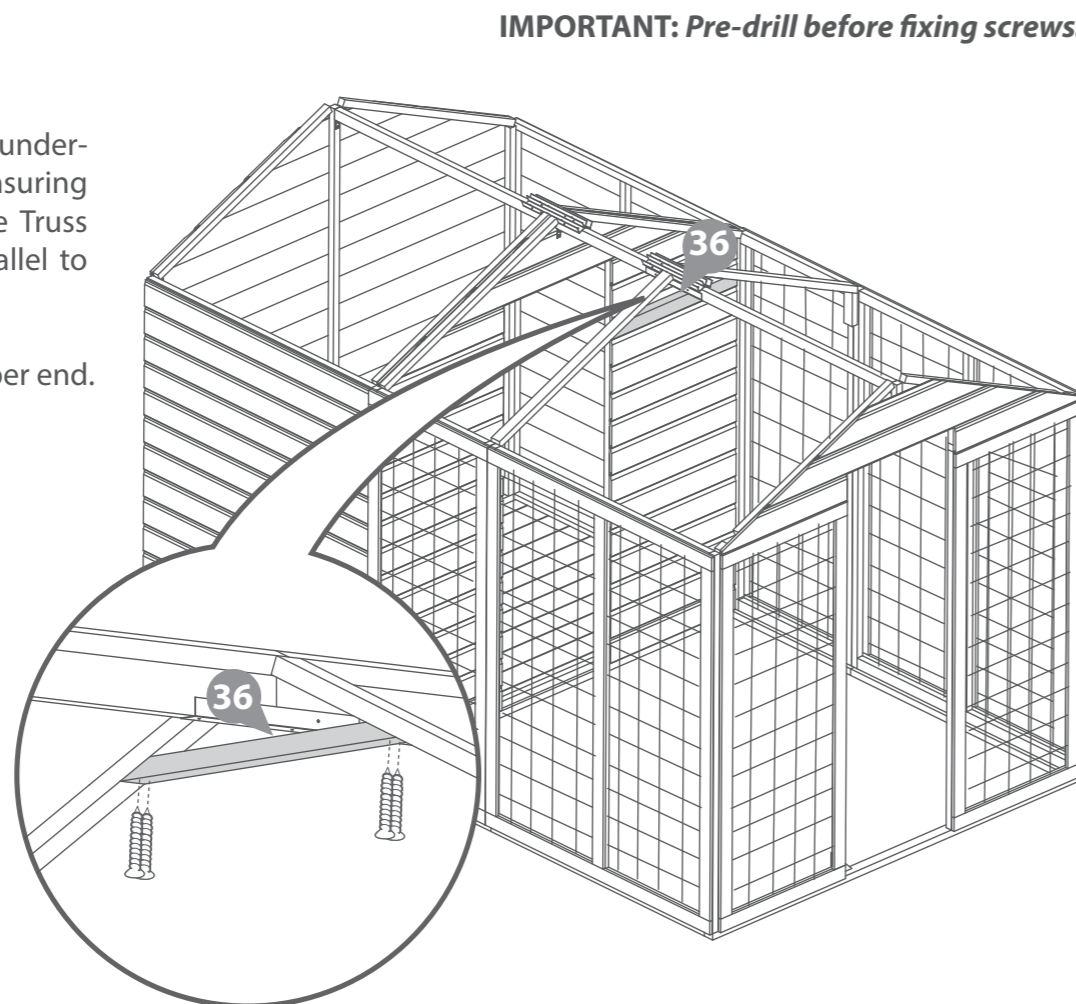
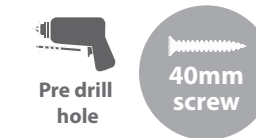

**Step 13**

Fix the Roof Panels in place using 32x40mm screws. Ensure to go through the Roof Panels and into the framing below.

**32x40mm screws**

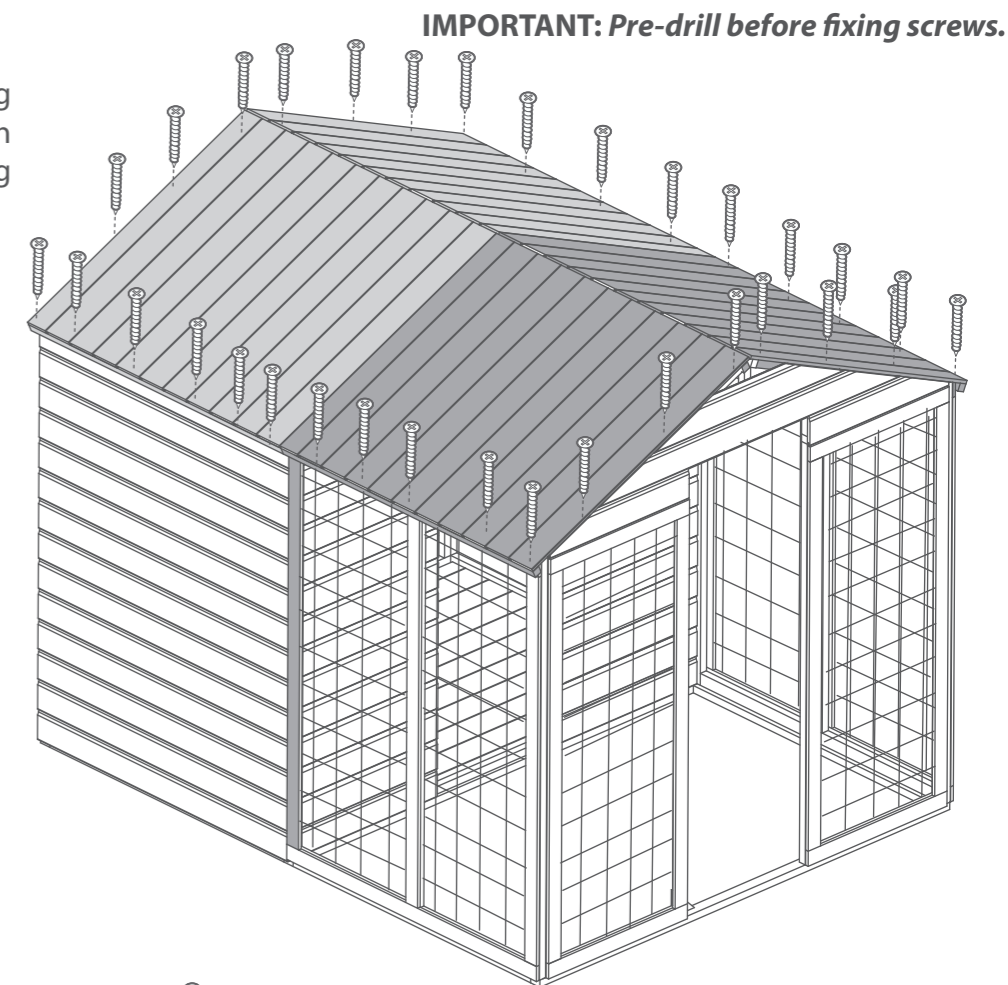
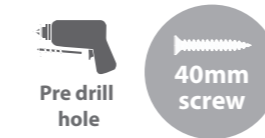

**10X6 EXTENSION PACK B**

**38x40mm screws**

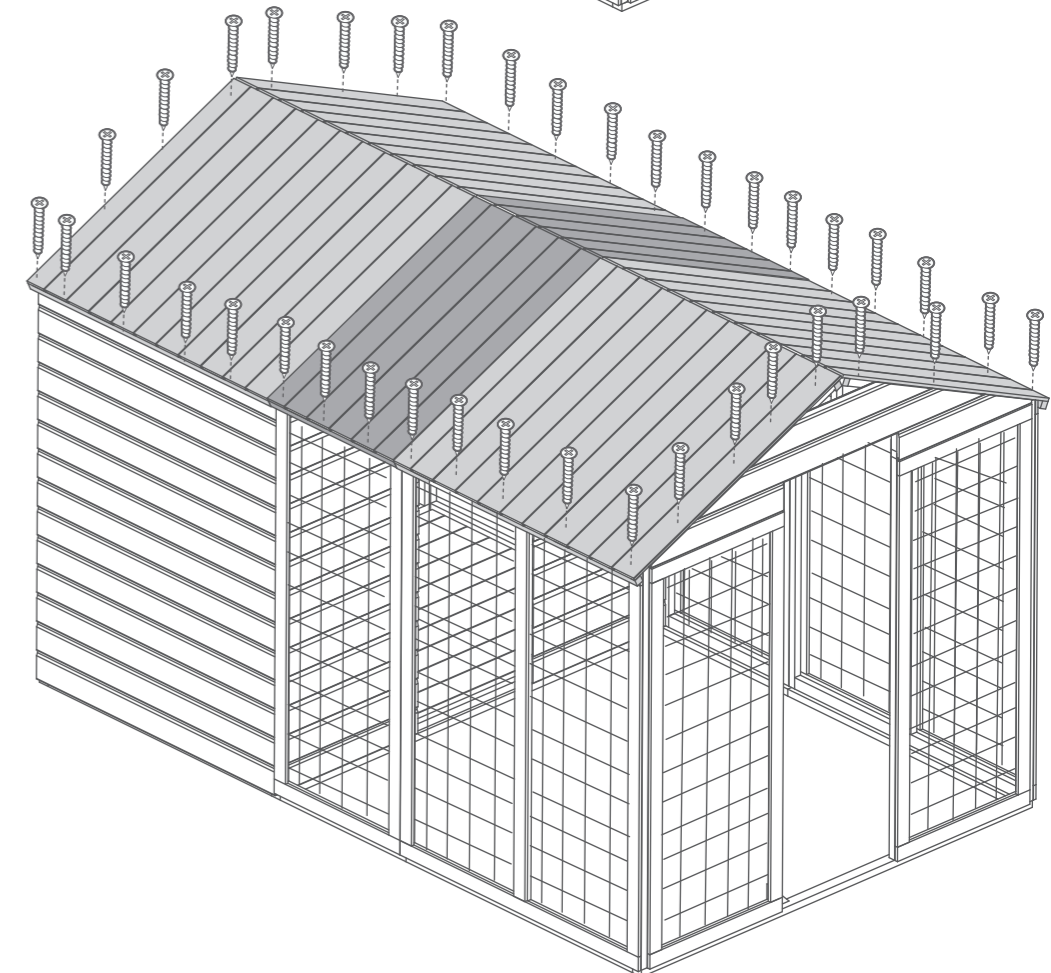

**Step 14**

Once the Roof is secure, fix the panels to the bearers.

For the inside of the kennel area, use 4x50mm screws per side.

For the Run area, use 4x70mm screws per side.

**16x50mm screws**  
**12x70mm screws**

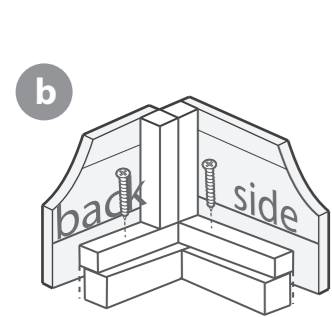

**10X6 EXTENSION PACK B**

**16x50mm screws**  
**16x70mm screws**

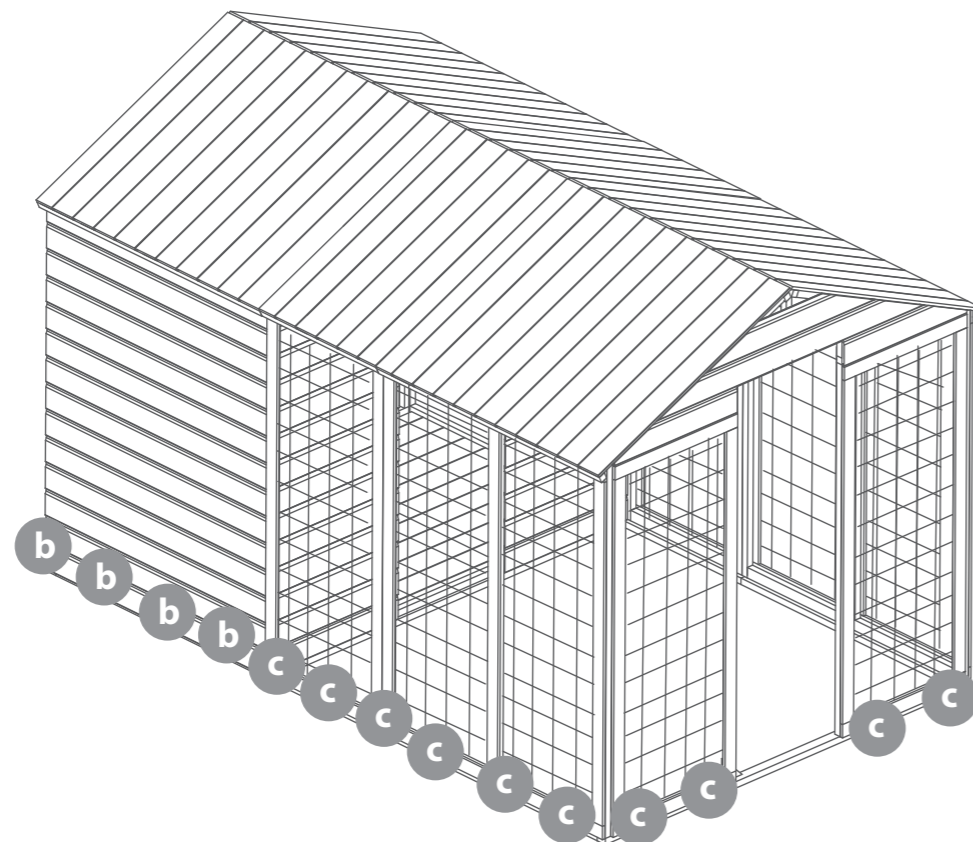

**IMPORTANT: Pre-drill before fixing screws.**

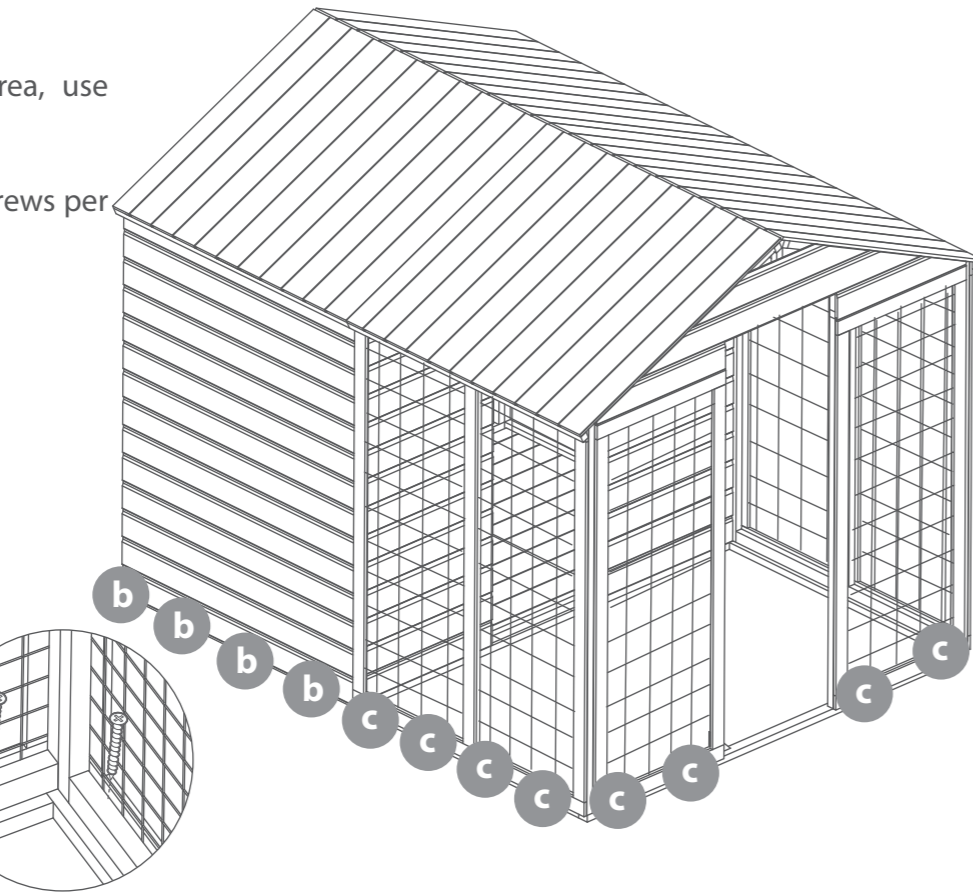

**Step 15**

**Parts Needed - No. 7 QTY 1**  
**- No. 8 QTY 1**  
**- No. 21 QTY 4**  
**- No. 23 QTY 4**

Fix the 4 x T Hinges (No.21) onto the doors (No. 7 & 8) and door frame as shown with 7x30mm screws.

Ensure that there is equal space around each side of the Doors and a space between the Doors so they can open freely of each other.

Fix the turn button (No.23) to the top and bottom of each door using 1x30mm black screw per turn button.

*Note: If you have a large dog then you may be more inclined to fit the larger door at the bottom.*

*\*8x6 building shown for illustrative purposes, the process is the same for the extension pack\**

**28x30mm screws.**  
**4x30mm Black screws**



**IMPORTANT: Pre-drill before fixing screws.**

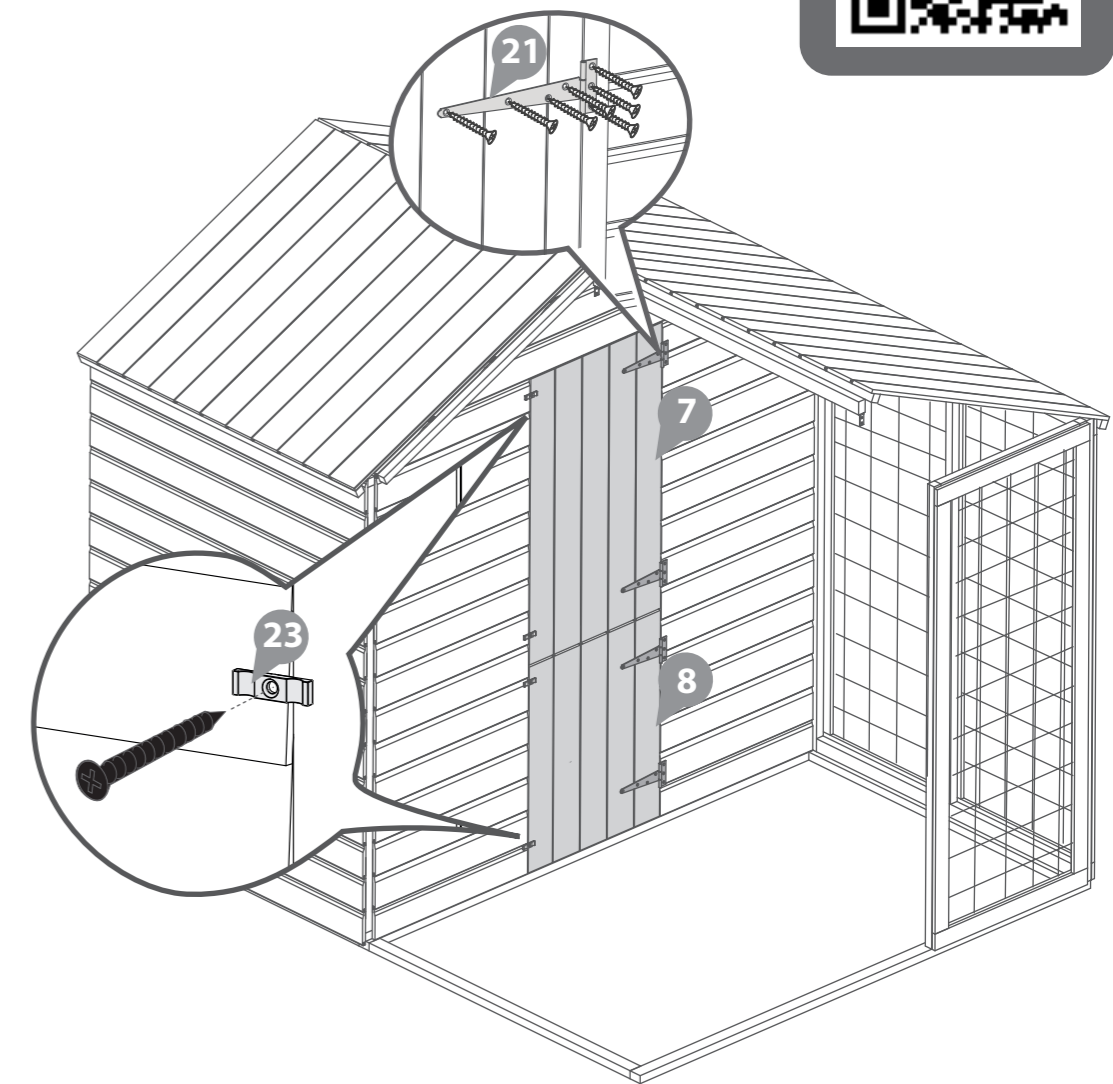

**\*Note: Hinges to go on the side with the shortest gap.**

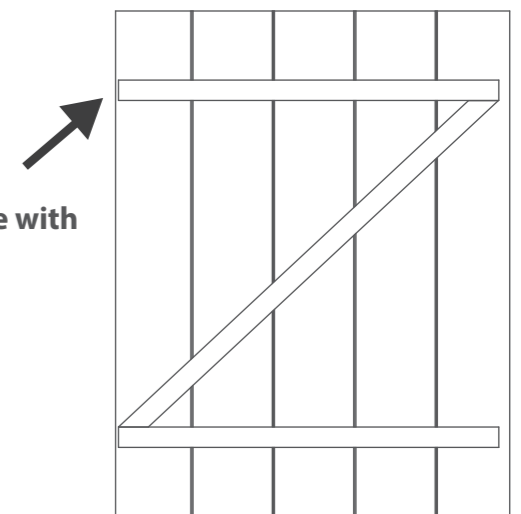

**Step 16**  
Parts Needed - No. 20 QTY 1

Locate the Door Strip (No.20) to the inside of the Door Panel on the opposite side to the hinges.

Fix in place using 4x30mm screws.

4x30mm screws.

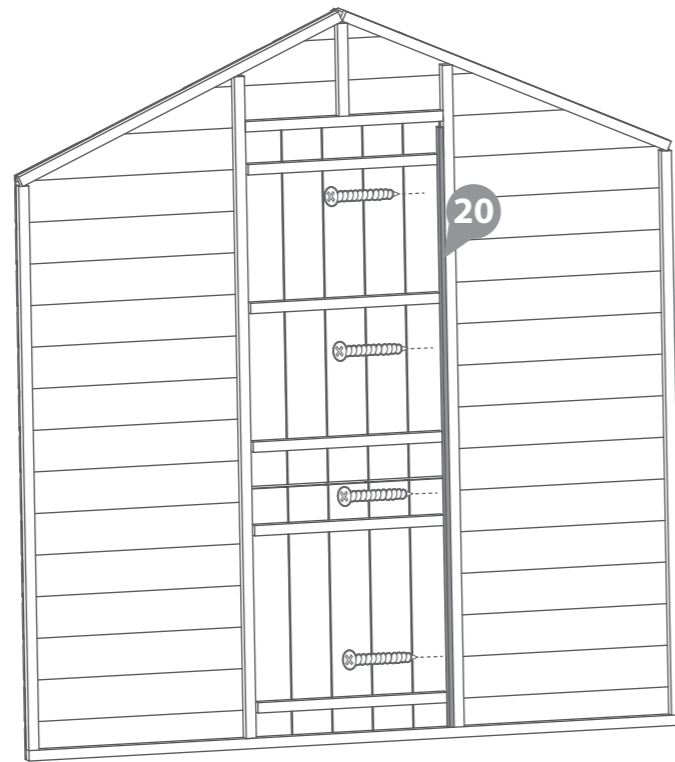
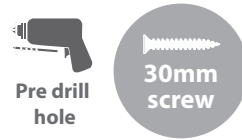

**IMPORTANT: Pre-drill before fixing screws.**

**Step 17**  
Parts Needed - No. 18 QTY 4

Locate the Cover Trims (No.18) to each corner of the building where the panels join.

Fix in place using 4x30mm screws per trim.

*\*8x6 building shown for illustrative purposes, the process is the same for the extension pack\**

16x30mm screws.

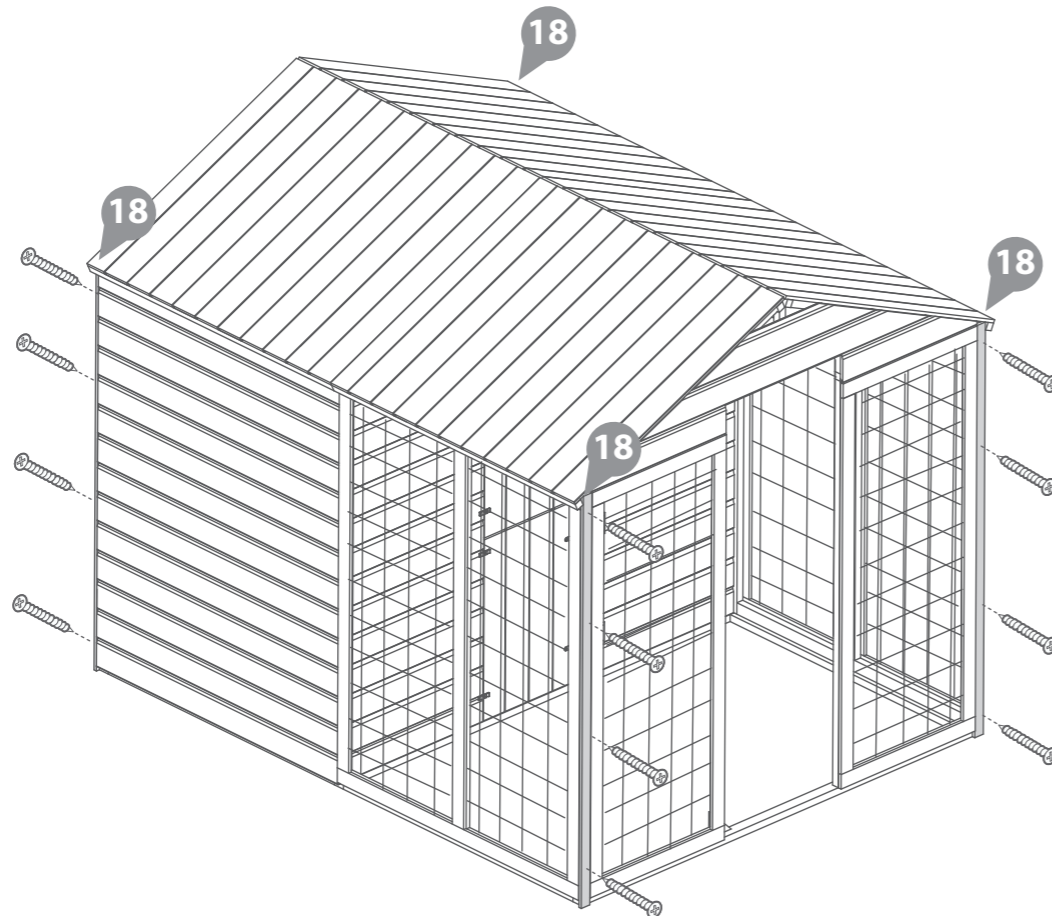

**IMPORTANT: Pre-drill before fixing screws.**

**Step 18**  
Parts Needed - No. 28 QTY 1  
- No. 29 QTY 1

Cut the Felt (No.28) into two strips measuring:  
8x6 = 2510mm (L) X 1000mm (W)  
10x6 = 3140mm (L) x 1000mm (W)

Cut the Capping Felt (No.29) into one strip measuring:  
8x6 = 2510mm (L) X 300mm (W)  
10x6 = 3140mm (L) x 300mm (W)

Lay the felt onto the building as shown in the illustration. Ensure to overlap each sheet by 100mm and that there is 50mm of overhang around the building.

Fix the felt in place using felt tacks at 100mm intervals.

100 x Felt Tacks



10X6 EXTENSION PACK B

150 x Felt Tacks

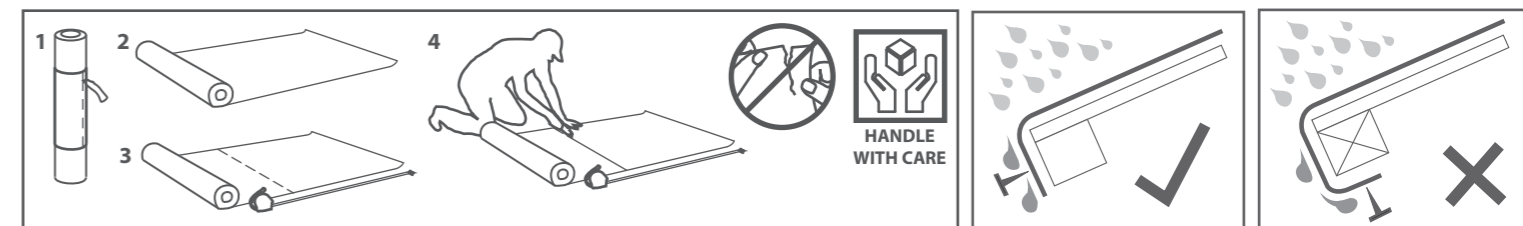
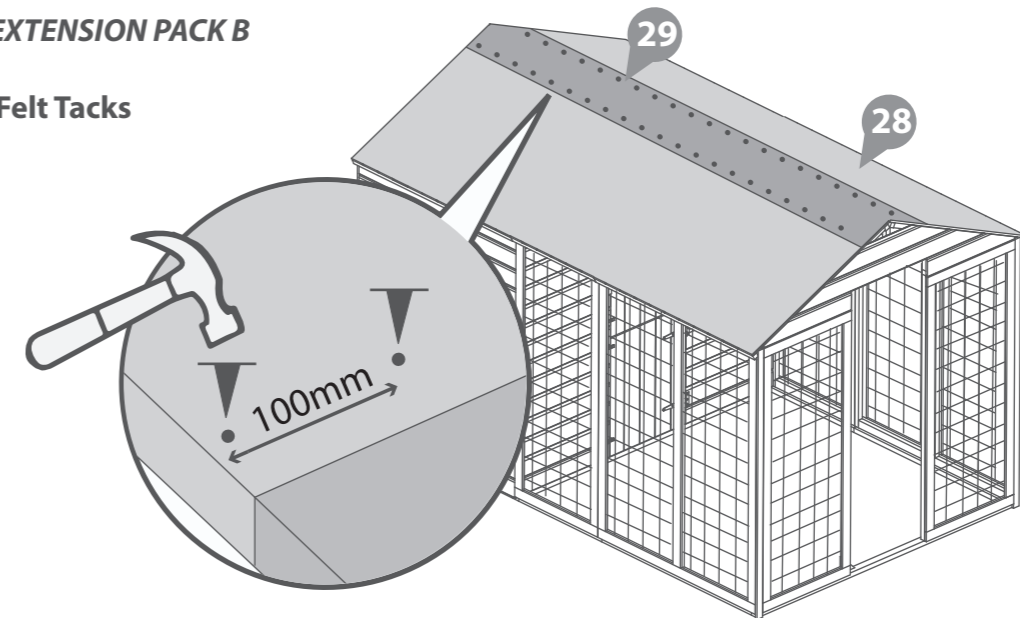
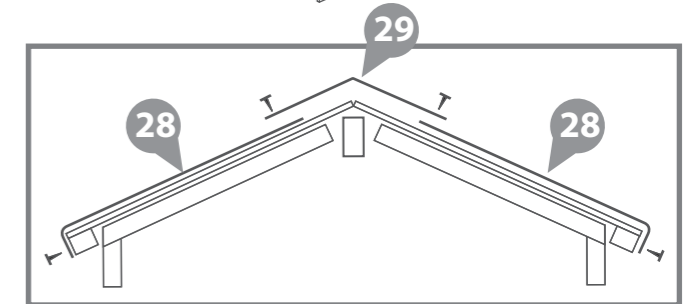
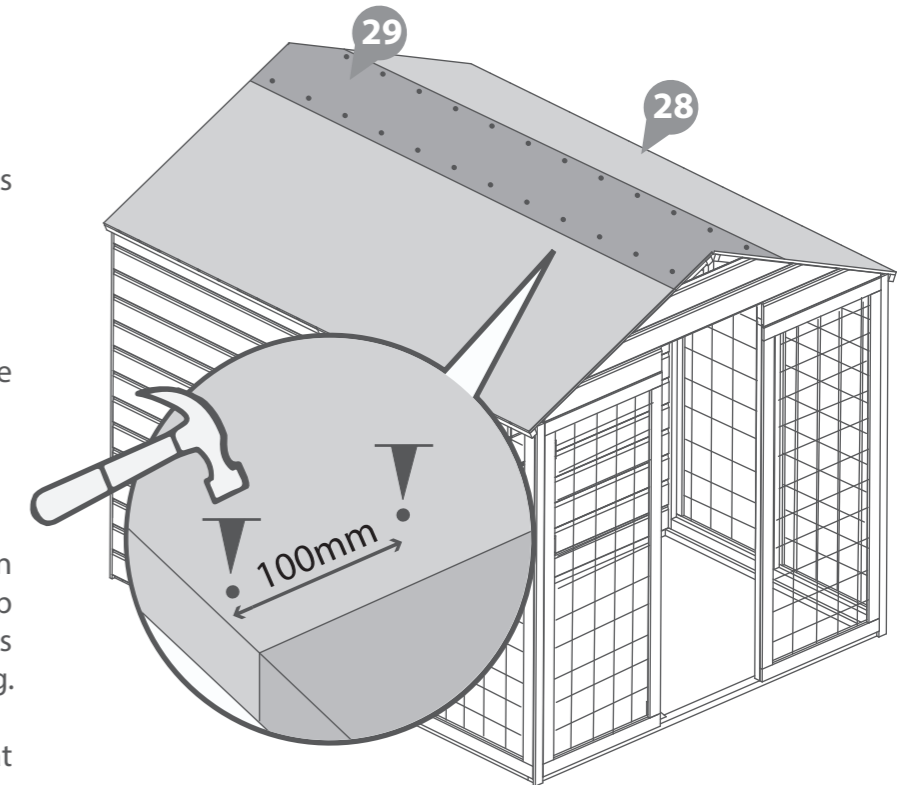

**Step 19**

- Parts Needed - No. 5 QTY 1**  
 - No. 21 QTY 3  
 - No. 23 QTY 2  
 - No. 25 QTY 1

Locate the Mesh Door (No.5) into the front door way. Fix 3 x T-Hinges (No.21) onto the door and door frame using 7x30mm screws per hinge.

Locate one Turn Button (No.23) to the top and bottom of the door. Fix in place using 1x30mm black screw per turn button.

Locate the Pad Bolt (No.25) to the horizontal brace on the front of the Mesh Door. Fix in place using 6x30mm screws. Fix the Pad Bolt Retainer to the Panel framing using 4x30mm screws.

*\*8x6 building shown for illustrative purposes, the process is the same for the extension pack\**

- 31x30mm screws.**  
**2x30mm black screws.**

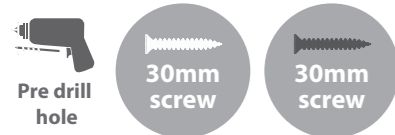

**IMPORTANT: Pre-drill before fixing screws.**

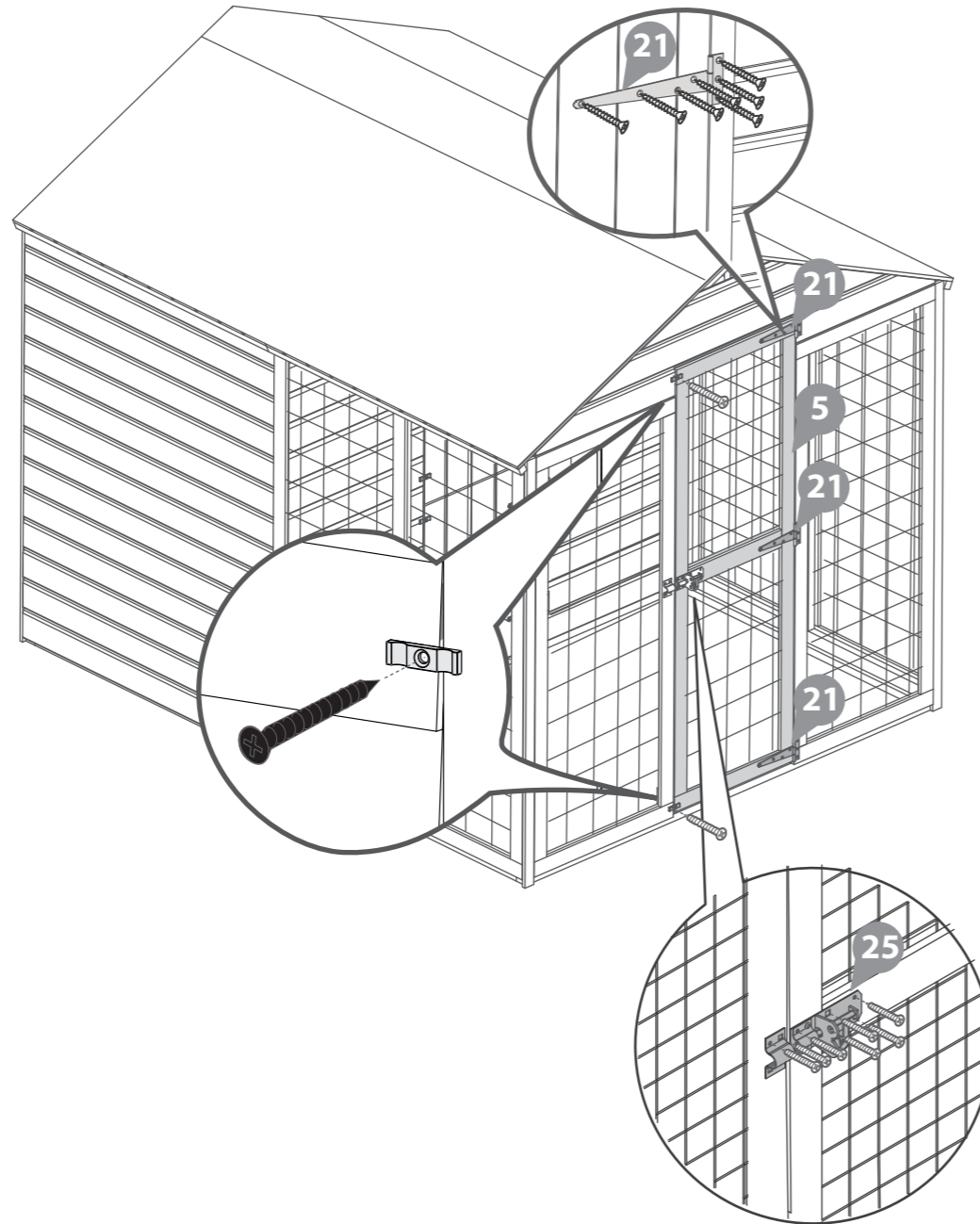

**Step 20**

- Parts Needed - No. 12 QTY 4**  
 - No. 27 QTY 2

Attach the Fascias (No. 12) to the front and back of the building using 4x40mm screws per fascia.

Once in place, cut off the excess material of the fascia with a hand saw.

Locate the Finials (No. 27) onto the Fascias and fix in place using 2x30mm screws per Finial.

*\*8x6 building shown for illustrative purposes, the process is the same for the extension pack\**

- 4x30mm screws**  
**16x40mm screws.**

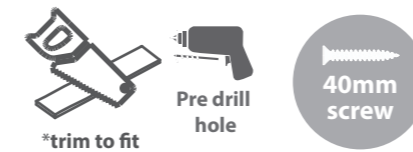

**Step 21**

- Parts Needed - No. 9 QTY 3**

Slot the Floor Panels (No. 9) into the kennel area, ensuring they rest on the bearers, are flush and aligned.

These Panels are removable so do not fix in place.

**IMPORTANT: Pre-drill before fixing screws.**

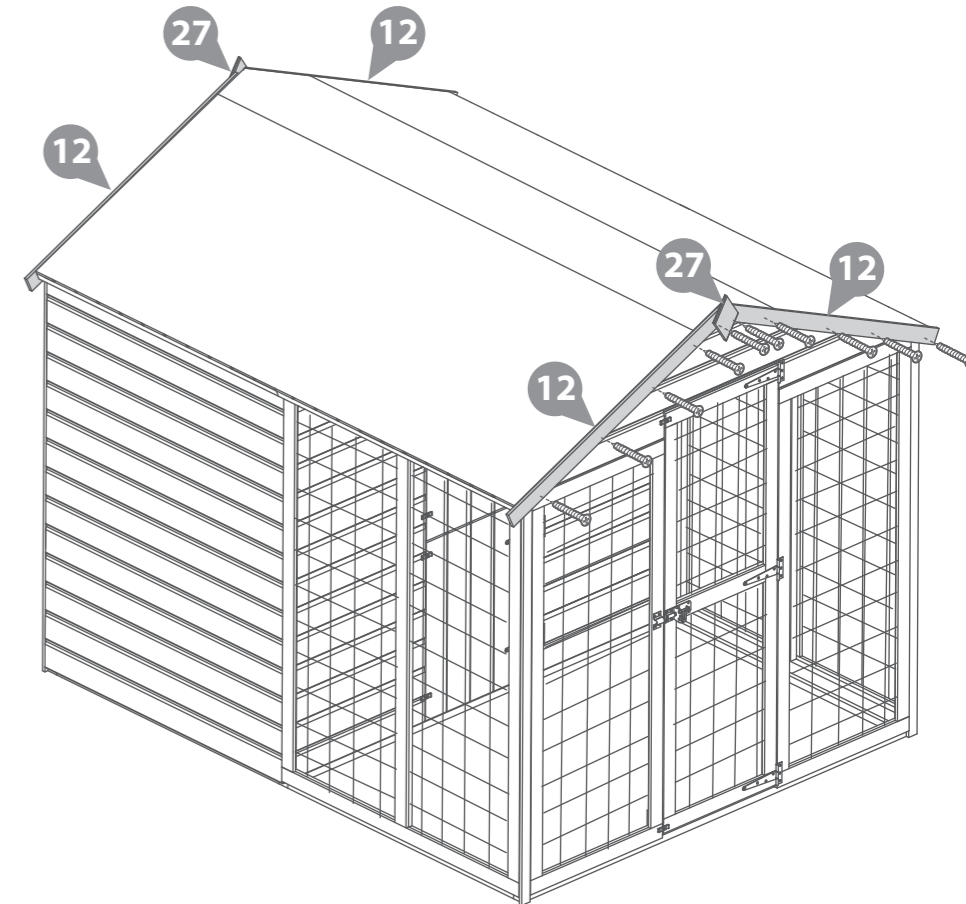

**IMPORTANT: Pre-drill before fixing screws.**

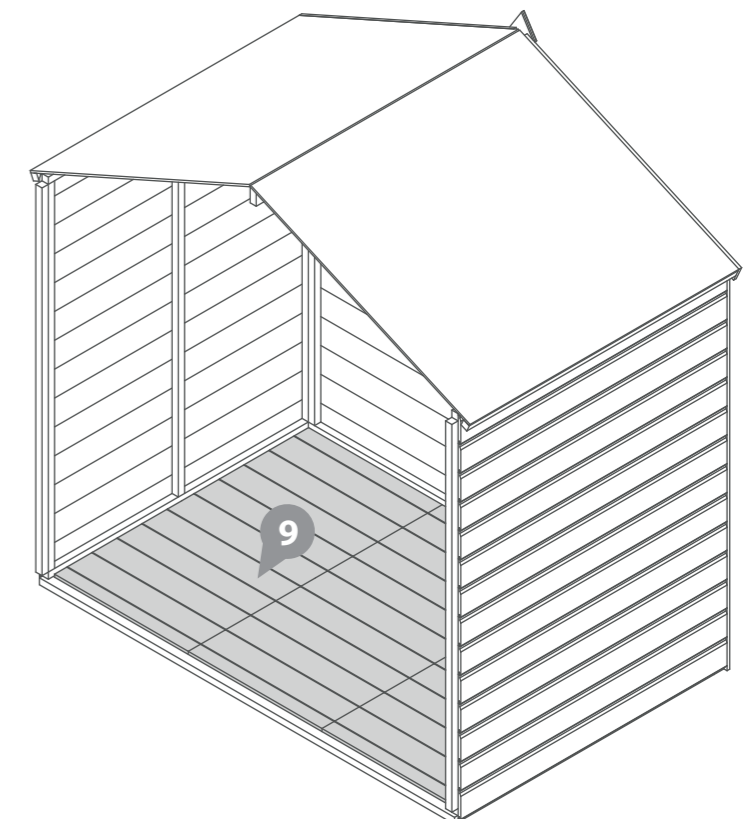





## LEAVE US A REVIEW...

Want to share your experience with us?  
Leave us a review on Feefo, TrustPilot or Google.

Your reviews help other people find and trust our business, as well as helping to play an important role in our growth and improvement!

## TREATING YOUR GARDEN BUILDING

Preservation of wood that's outdoors is vital. A little early care will help protect your garden building, improve its appearance and ensure maximum longevity. Insects, moisture, salt, and changing weather can have dramatic effects on the stability and appearance of your garden building. Once your building is installed, you've checked it over and you're happy with it, you can take a few basic precautions to prepare it for the elements. Treating your garden building helps prevent decay and, by repelling water, discourages the growth of moulds and fungi that could jeopardise the structural integrity of the wood.

**Dip Treated buildings** - Require a preservative treatment to protect against rot and decay and a waterproof treatment to prevent water ingress  
**Pressure Treated buildings** - Require a waterproof treatment to prevent water ingress  
**Log Cabins/Insulated Garden Rooms** - Are supplied untreated and require a preservative and waterproofing treatment.

PLEASE SCAN HERE:



**ANY QUESTIONS?**  
Scan the QR code to contact us via our customer portal.

To apply a preservative and water proofing treatment (pressure treated products do not require a preserver), follow the manufacturer's instructions but in principle, stick to the following steps:

- ✓ Wear latex or rubber gloves, eye protection and (if spraying) a mask.
- ✓ Prepare the wood, by sanding down any ridges or inconsistencies in the wood, smoothing out knots and end-cuts.
- ✓ Choose a dry day to treat your garden building. If you're spraying rather than brushing paint on, avoid a windy day.
- ✓ Be sure you can safely reach all the sections you need to paint - and if you need a ladder, make sure it's safely positioned before climbing. Lay dust sheets around to avoid paint splatters on your base or surrounding plants.
- ✓ Tape around windowpanes to avoid smears when you're painting the frames.
- ✓ Keep pets and small children out of the way. The last thing you want is to have fur on your garden building paint, or little painted footprints all over your garden and home.
- ✓ Fill any gaps in the building's body with caulk or wood filler to prevent water and draughts getting in. Silicone based caulk is flexible and will move with the timber when temperature and humidity change. Allow to dry completely before treating. A handy tip for finding gaps is to go into your garden building and look for light leaking through joints and frames. If light gets in, then so will water.
- ✓ Liberally apply at least two coats of the treatment products with a brush or spray, taking care to allow the first coat to completely dry before applying the second.
- ✓ Make sure the solution permeates the whole of the surface area, especially around natural cracks, end cuts and nail/screw holes.



**APPLY WOOD TREATMENT  
IMMEDIATELY  
AFTER ASSEMBLY**

PLEASE SCAN HERE TO SEE TREATMENT VIDEO:



## 1 Perimeter

Check around the perimeter of your product to ensure there are not trees or plants that are in contact with or overhanging the building. This can affect airflow and overhanging trees, or branches can damage the roof, it is advised to keep plants at a distance.

## 2 Repair

Inspect the interior and exterior of the product to look for splits, cracks, and holes. Although this is a natural occurrence it can be prevented. A wood filler can be used to close the splits, cracks, and holes.

## 3 Roof

Check your roof regularly for tears, splits, damaged wood and fallen debris. If you notice any of this immediate repair is critical.

## 4 Doors & Windows

Expansion and contraction can cause doors and windows to stick or become difficult to open. Small adjustments to the hinge position can be made to the doors and windows to allow free movement.

## 5 Oil

Hinges can seize up over time, apply lubricant to the hinges and locks annually.

## 6 Screws & Bolts

It is advised to check all screws and bolts and tighten any loose you might find. For log cabins specifically the storm braces will require loosening. During humidity and temperature changes (seasons) to allow expansion and contraction to prevent gaping, twisting, popping, and warping.

## 7 Wash

At least once a year, give the outside of you building a good wash, to remove cobwebs, leaves, or any other dirt that may accumulate on the exterior.

## 8 Airing

Airing your product regularly prevents the build up of condensation which can cause the timber to rot and mould. Condensation can build up over time or daily, it is caused by a rise and fall in temperature. Leaving doors and windows open regularly can help combat the natural moisture build up.

## 9 Clean & Tidy

It is good practice to clean the inside and outside of your product regularly. Clear out the contents, sweep the floor, remove dirt and cobwebs. Check for areas of damp and investigate the cause to remove and prevent future occurrences. Check the ground around your product for build up of debris such as leaves, remove and ensure there is clear ventilation underneath the floor.

### Additional Playhouse Maintenance:

It is recommended that the following checks and maintenance are carried out at the beginning of each season as well as at regular intervals during the usage season.

- Check all nuts /bolts/ screws for tightness and tighten when required.
- Check for movement / opening of wood giving rise to protrusion of nail heads and tips.
- Check hinges.
- Replace defective parts in accordance with the manufacturers instructions.
- Check any crossbeams, suspensions and anchors.
- If a swing is included; check the swing seat, chains and ropes.

**IF THESE CHECKS ARE NOT CARRIED OUT THE ACTIVITY TOY COULD BECOME A HAZARD**

All our garden buildings have been designed and manufactured with care and attention to be the perfect addition to your outdoor space. To ensure you do get the best out of your new garden building and to increase the longevity we advise that you follow the product instructions and our manufacturer's recommendations as detailed below. Thank you for choosing a Mercia Garden product!

## 1 Choosing the most suitable location for your garden building...

A minimum of 60cm should be left around the perimeter of your garden building to allow access for maintenance, annual treatment and to allow air flow around the building.

Where possible you should avoid placing your garden building underneath large trees to prevent the tree causing damage to the building.

## 2 Preparing the base for your garden building...

All our buildings must be built on a firm, level base to ensure the longevity of the building and prevent the wood from distorting. We recommend either concrete, concrete slabs or a wooden base, such as our 'Portabase'.

The base should be slightly smaller than the external measurement of the building, i.e. the cladding should overlap the base, creating a run off for water and preventing water from pooling underneath the building.

We also recommend that the floor of the garden building is a minimum of 25mm above the surrounding ground level to avoid flooding.

## 3 After installation...

Once your garden building has been installed, it will need to be treated within 14 days (weather permitting) and annually to prevent the timber from deteriorating and to waterproof it. This is required to maintain the anti-rot guarantee.

Dip Treated buildings - Require a preservative treatment to protect against rot and decay and a waterproof treatment to prevent water ingress.

Pressure Treated buildings - Require a waterproof treatment to prevent water ingress.

Log Cabins/Insulated Garden Rooms - Are supplied untreated and require a preservative and waterproofing treatment.

We also recommend using a silicon sealant on the inside and outside of the windows as soon as possible after assembly and treatment to fully seal the windows.

Roofing felt/covering should be checked annually and replaced or fixed accordingly.

## 4 General maintenance and wood characteristics

As wood is a natural material it may be affected by the following:

**Shrinkage and warping** - The timber used in the construction of your garden building will have retained some of its natural moisture content. The moisture content of the timber will vary, depending upon prevailing environmental conditions, which will result in the components either naturally expanding or contracting. As the components dry out, shrinkage may occur. A good waterproofing treatment from the start is the best protection to minimise the effect of moisture loss/intake.

In extended periods of very warm weather getting some moisture to the building will help the overall balance. You can do this by spraying it down lightly with a garden hose. In contrast, after snow fall try to remove the snow as best as possible from the roof to prevent moisture intake and to remove the extra weight.

Top tip - using a garden brush will help you to reach the highest part of the building to remove snow and any debris left from bad weather.

**Damp and mould** - During the winter months, cold and damp conditions can result in an increased amount of moisture within your garden building, especially when used infrequently. Condensation can form on the timber and other items stored within your garden building. If left this moisture is likely to cause mould and mildew.

To prevent the build-up of moisture, we recommend leaving the door or windows of your building open from time to time, to allow the fresh air to circulate. We also advise against storing wet or damp items in your garden building as this will also increase the level of moisture in the building. If mould or mildew does start to form within your building we recommend using an anti-mould cleaner to remove it and to prevent it spreading, which if left untreated could permanently damage your garden building.

**Splits, cracks and knots** - You may notice small splits and cracks in some components or holes may appear where knots shrink and fall out. This will not affect the structure of your Garden building however, if you wish to fill them this can be easily done using any good quality wood filler.

**Sap** - is naturally occurring in wood and may appear in some boards of your garden building. If you wish to remove the sap, we advise waiting until it is dry and then using a sharp knife to carefully remove it. If the removal of the sap causes a hole in the timber, we recommend using a good quality wood filler to fill it.

For more handy hints and tips on how to care and maintain your garden building please refer to the MGP Customer Portal at [www.mgplogistics.co.uk](http://www.mgplogistics.co.uk)

### Any further questions?

Contact our  
Customer Service Team via the MGP  
Customer Portal at:  
[www.mgplogistics.co.uk](http://www.mgplogistics.co.uk)

## 1

### Manufacturer's Warranty

All Mercia Garden Products are supplied with a 1 year warranty on all parts against manufacturing defects.

This warranty does not cover movement, warping or splitting of timber products over time.

This warranty will be voided if any of the following occur:

1. The building has been customised or modified/adapted in any way.
2. The person claiming is not the original purchaser of the building.
3. Any damage has been caused by or as a result of misuse.
4. The building has not been maintained and cared for in accordance to our advisories and manufacturer's recommendations.
5. The building has not been treated annually or as per the manufacturer's recommendations, please ensure receipts are kept to validate this claim.
6. The building has not been erected, fitted or installed as per the supplier instructions.
7. The building has not been erected on a suitable sized firm flat, solid level concrete/slab base or placed on pressure treated bearers.
8. The building is or has been placed with 2 feet (600mm) of any obstructions (walls, trees, plants, fences etc.) which can allow moisture to penetrate the timber.
9. The roofing felt has been incorrectly fitted or damaged, allowing water ingress, or has not been properly maintained.
10. Any windows and joints have not been sealed, inside and out, with silicone or other watertight sealant.
11. Any timber has been cut, pierced or drilled without subsequent application of approved cut-end treatment.

## 2

### Anti-rot Guarantee

Mercia Garden Products offer a 10 year anti-rot guarantee on all dip treated (a preparatory treatment) and 15 years on all pressure treated products. This guarantee covers solid timber against rot, decay, blue stain and insect attacks.

To validate the guarantee, the building must be treated (as detailed within manufacturer's recommendations) within 14 days (weather permitting) of assembly and annually thereafter.

This guarantee does not cover movement, warping or splitting of timber products over time.

This guarantee will be voided if any of the following occur:

1. The building has been customised or modified/adapted in any way.
2. The person claiming is not the original purchaser of the building.
3. Any damage is caused by or as a result of misuse.
4. The building has not been maintained and cared for in accordance to our advisories and manufacturer's recommendations.
5. The building has not been treated annually or as per the manufacturer's recommendations, please ensure receipts are kept to validate this claim.
6. The building has not been erected, fitted or installed as per the supplier instructions.
7. The building has not been erected on a suitable sized firm flat, solid level concrete/slab base or placed on pressure treated bearers.
8. The building is or has been placed with 600mm of any obstructions (walls, trees, plants, fences etc.) which can allow moisture to penetrate the timber.
9. The roofing felt has been incorrectly fitted or damaged allowing water ingress, or has not been properly maintained.
10. Any windows and joints have not been sealed, inside and out, with silicone or other watertight sealant.
11. Any timber has been cut, pierced or drilled without subsequent application of approved cut-end treatment.



REGISTER FOR YOUR  
**ANTI-ROT**  
GUARANTEE TODAY

PLEASE SCAN HERE:

