

01DTPRMSHDB0808DDOP-V1
8X8 PREMIUM DUTCH BARN.



x2 All buildings should be erected by two adults



Winter = High Moisture = Expansion
 Summer = Low Moisture = Contraction

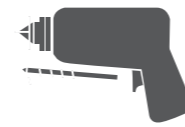

2mm Drill bit

For ease of assembly, you **MUST** pilot drill all screw holes and ensure all screw heads are countersunk.



CAUTION
 Every effort has been made during the manufacturing process to eliminate the prospect of splinters on rough surfaces of the timber. You are strongly advised to wear gloves when working with or handling rough sawn timber.



For ease of assembly, you will need a tape measure to check dimensions of components.

Screws & Nails



Measure overall length

Bolts

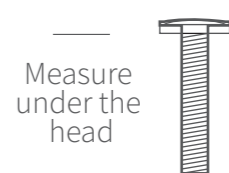

Measure under the head

To identify the fixings required for each step use a measuring tape.

****Protim Aquatan T5 (621)****

Your building has been dip treated with Aquatan.

Aquatan is a water-based concentrate which is diluted with water, the building as been treated by the correct application of Aquatan solution and then allowed to dry.

Aquatan is a decorative finish to colour the wood, which is applied industrially to timber fence panels and garden buildings.

Aquatan undiluted contains: boric acid, sodium hydroxide 32% solution, aqueous mixture of sodium dioctyl sulphosuccinat and alcohols: 2, 4, 6-trichlorophenol.

BEFORE YOU START PLEASE READ INSTRUCTIONS CAREFULLY

- Check the pack and make sure you have all the items listed in the parts list provided.
- When you are ready to start, make sure you have the right tools at hand (not supplied - see the equipment list on next page).
- Ensure there is plenty of space and a clean dry area for assembly.
- Ensure you have enough time to build the product to ensure the building is water tight.

LOCATION FOR YOUR GARDEN BUILDING

A minimum of 600mm should be left around the perimeter of your garden building to allow access for maintenance, annual treatment and to allow air flow around the building.

Where possible you should avoid placing your garden building underneath large trees to prevent the tree causing damage to the building.

TIMBER

As with all natural materials, timber can be affected during various weather conditions. For the duration of heavy or extended periods of rain, swelling of the wood panels may occur. Warping of the wood may also occur during excessive dry spells due to an interior moisture loss. Unfortunately, these processes cannot be avoided but can be helped. It is suggested that the outdoor building is sprayed with water during extended periods of warm sunshine and sheltered as much as possible during rain or snow.

Once your garden building has been installed it will need to be treated within 14 days (weather permitting) and annually to prevent the timber from deteriorating and to waterproof it. This is required to maintain the anti-rot guarantee.

Dip Treated buildings - Require a preservative treatment to protect against rot and decay and a waterproof treatment to prevent water ingress

Pressure Treated buildings - Require a waterproof treatment to prevent water ingress

Log Cabins/Insulated Garden Rooms - Are supplied untreated and require a preservative and waterproofing treatment.

BUILDING A BASE

When thinking about where the building and where the base is going to be constructed: Ensure that there will be access to all sides for maintenance work and annual treatment.

Ensure the base is level and is built on firm ground, to prevent distortion. Refer to diagrams for the base dimensions, The base should be slightly smaller than the external measurement of the building, i.e. The cladding should overlap the base, creating a run off for water. It is also recommended that the floor be at least 25mm above the surrounding ground level to avoid flooding.

TYPES OF BASE

- Concrete 75mm laid on top of 75mm hard-core.
- Slabs laid on 50mm of sharp sand.
- Wooden base.

Whilst all products manufactured are made to the highest standards of safety and in the case of children's products independently tested to EN71 level, we cannot accept responsibility for your safety whilst erecting or using this product.

REGISTER FOR YOUR
ANTI-ROT
 GUARANTEE TODAY

PLEASE SCAN HERE:

In all instances for assistance with your product, please contact us via our customer portal: <https://www.mgplogistics.co.uk/>.

Mercia Garden Products Limited,
 Sutton On Trent,
 Newark,
 Nottinghamshire,
 NG23 6QN

TO DO LIST

- Find a suitable location to build *(see front cover for further information).*
- Build a base *(see front cover for further information).*
- Check the base is flat, level, clear of debris and has 60cm clearance on all sides.
- Check you have the required equipment.
- Check you have all the product items listed *(if you have missing or damaged parts please contact the customer services department, see front cover for contact details).*
- Install the product as per the step by step instructions within this pack.
- Prepare the product ready for treatment.
- Apply a preserving and a waterproofing treatment within 14 days *(weather permitting)* of installation *(pressure treated products do not require a preserver).*
- Register for your anti rot guarantee *(scan the QR below).*
- Tidy the build area and dispose of any remaining parts responsibly.
- Maintain your building *(see the manufacturers recommendations at the back of this pack).*

EQUIPMENT LIST

- Hammer
- Flat Head Screwdriver
- Drill
- Drill Bit Set
- Phillips and Slotted Bit Sets
- Tape Measure
- Hand Saw
- Spirit Level
- Ladders/Steps
- Stanley Knife/Cutting Tool
- Sand Paper
- Gloves
- Silicone (For Windows Only)
- Wood Filler (Optional)
- Timber Preservative Treatment *(not pressure treated products)*
- Timber Water Proofing Treatment
- Treatment Mixing Stick
- Paint Brush/Sprayer/Roller

NEED EXTRA SUPPORT

If you are unsure that your base preparation will be suitable, please contact us on 01636 821215 to discuss this further.

Alternatively, you can visit our website or MGP Logistics Online Portal for some further shededucation.

Website:

<https://www.merciagardenproducts.co.uk/sheducation>

MGP Logistics Online Portal:

<https://www.mgplogistics.co.uk/>

Here you will find plenty of useful information that'll help with most pre-installation and maintenance queries.

PLEASE SCAN HERE:



ANY QUESTIONS?

Scan the QR code to contact us via our customer portal.

NOTES

ACCESSING VIDEO GUIDES...

Some steps within this set of instructions come with an added video guide for your convenience. These can be accessed via the QR code and used to aid you in constructing that step. See below for how to use.

You can also find all the videos on our youtube channel:
<https://www.youtube.com/@merciagardenproducts8716/videos>

1. Find the QR code within the instruction step...

Step.....

Parts Needed- No. QTY 1
No. QTY 1
No. QTY 1



Within the instruction step, there will be an icon in the top right that has a QR code in. This is where the video can be accessed from.

Please note: not every step has a video guide.

2. Open camera app...

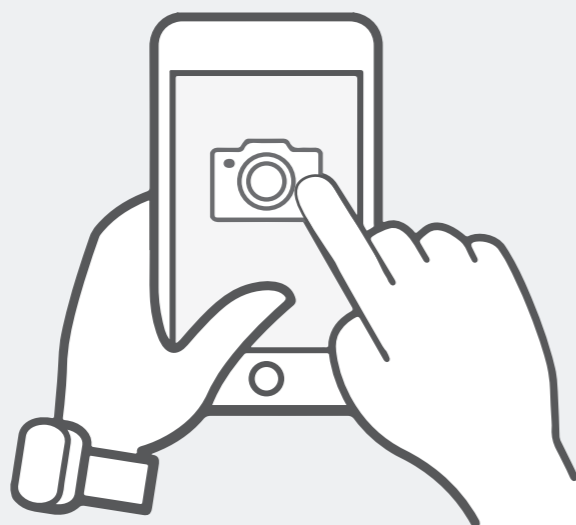

On your personal smart device (phone, tablet etc), open your camera app or QR code scanner app.

ACCESSING VIDEO GUIDES...

3. Scan QR code...



To scan the QR code, hold the camera over the QR code so that it can be seen on the screen. Once the QR code has been registered, follow the prompts on your device to open the video. (This will vary depending on your device.)

Please note: Ensure to use the back camera of your smart device as this will scan the QR code more accurately.

4. Watch the video...



The video guide will now be displayed on your smart device.

Disclaimer: The garden building constructed in the video guides may be constructed differently to your building. Please ensure to read your instructions carefully to avoid error.

Before assembly
please make sure you have a
suitable base ready to erect your
building



MADE IN GREAT BRITAIN

Overall Dimensions: Width = 2539mm
Depth = 2408mm
Height = 2626mm
Base Dimensions: Width = 2350mm
Depth = 2350mm

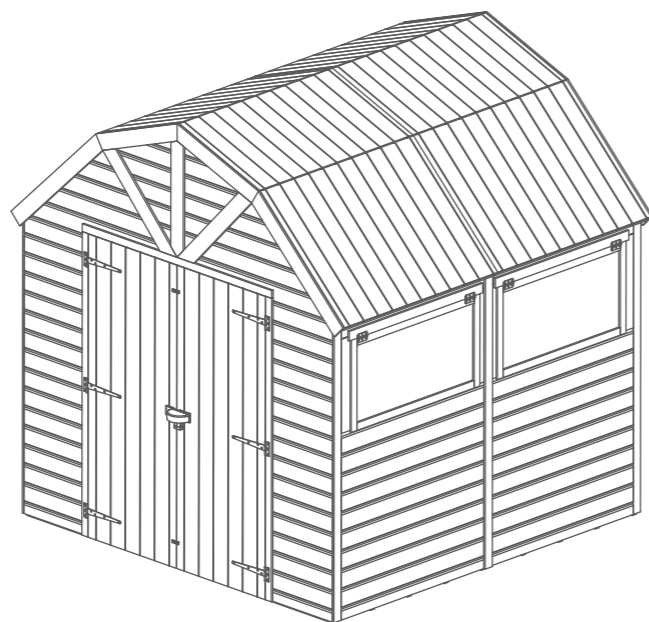

1

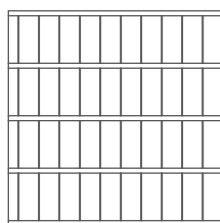

Floor QTY 4

AI-S21MBF1175X1175-V1

2

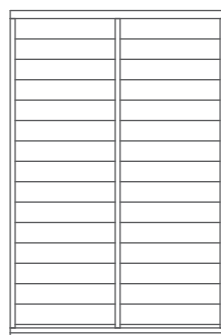

Back Panel

Width 1180mm QTY 2

AI-S21SHPP1180X1796-V1

3

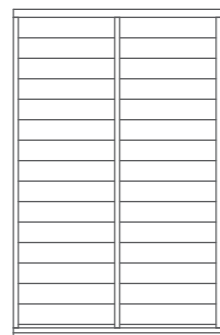

Side Panel

Width 1417mm QTY 2

AI-S21SHPP1136X1814-V1

4

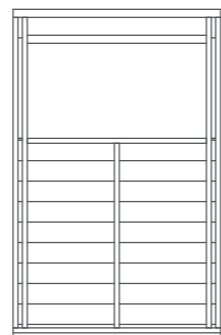

Window Panel QTY 2

AI-01S21SH1LFW1136X1814-V1

5

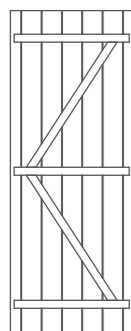

Door QTY 2

AI-S21FBMBZBD676X1770-V1

6



Front Panel QTY 2

AI-S21SHPPTOV512X1761-V1

7

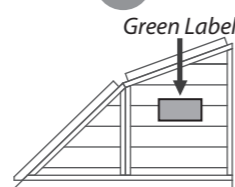

Gable Top Right QTY 2

AI-S22HDBGTR1180X817-V1

8

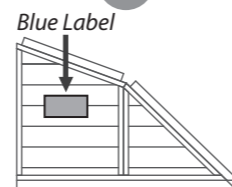

Gable Top Left QTY 2

AI-S22HDBGTL1180X817-V1

9



Lower Truss QTY 2

AI-S22HDBTF800X88-V1

10



Upper Truss QTY 2

AI-S22HDBTF629X88-V1

11



Top Roof QTY 4

AI-S21MBDBR1192X654-V1

12

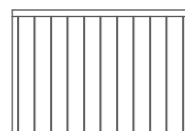

Bottom Roof QTY 4

AI-S21MBDBR1192X898-V1

13

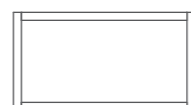

Window QTY 2

AI-FW1000X540-V1

14



Floor Blocks
27x44x400mm QTY 8

F2744-400MM

15

Door Cloaking Strip 27x44x1670mm QTY 1

F2744-1670MM

16

Door Strip 12x45x1449mm QTY 1

S1245-1449MM

17

Door Strip 12x45x1772mm QTY 2

S1245-1772MM

18

Window Strip 12x56x1037mm QTY 2

S1256-1037MM

19

Cover Trims 12x56x1790mm QTY 7

S1256-1790MM

20

Gable Cover Trims 12x56x710mm QTY 1

S1256-710MM

21

Top Door Framing 44x44x280mm QTY 2

F4444-280MM

22

Top Door Framing 44x44x1800mm QTY 1

F4444-1800MM

23

Bottom Door Framing 27x44x1336mm QTY 1

F2744-1336MM

24

Barge Board 12x95x678mm QTY 1

S1295-G-678MM

25

Fascia 12x95x900mm QTY 4

S1295-G-900MM

26

Barge Board 12x95x734mm QTY 2

S1295-G-734MM

27

Fascia 12x95x662mm QTY 4

S1295-G-662MM

28

Gable Strip 12x121x2090mm QTY 2

WB-2090MM



29 Truss Brace 27x44x1640mm QTY 2
F2744-G-1680MM



30 Door Blocks 27x44x150mm QTY 2
F2744-150MM



31 Truss Blocks 27x44x150mm QTY 2
F2744-G-170MM (Finished length 150mm, 1 x angled cut.)



32 Casement Stay QTY 2
PI-07-0007



36 Butt Hinge QTY 4
PI-07-0066



39 Hasp and Staple Lock QTY 1
PI-07-0221

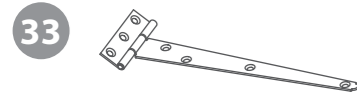

33 T Hinge QTY 6
PI-07-0021

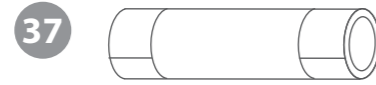

37 Felt QTY 1
PI-01-0003

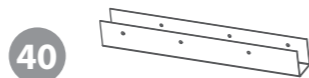

40 U Channel QTY 4
PI-07-0013

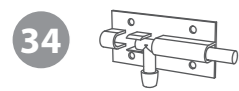

34 Tower Bolt QTY 2
PI-07-0030

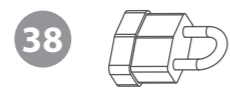

38 Weatherproof Lock QTY 1
PI-07-0222

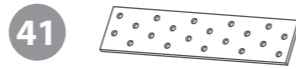

41 Joining Plates QTY 6
PI-07-0220



35 Turn Button QTY 2
PI-07-0034

Pre Assembly

Before assembling remove the transportation blocks from the bottom of each panel.

Take care removing the blocks as to not damage the panels. Tap with a flat headed screwdriver and hammer.

Dispose of the blocks once removed.

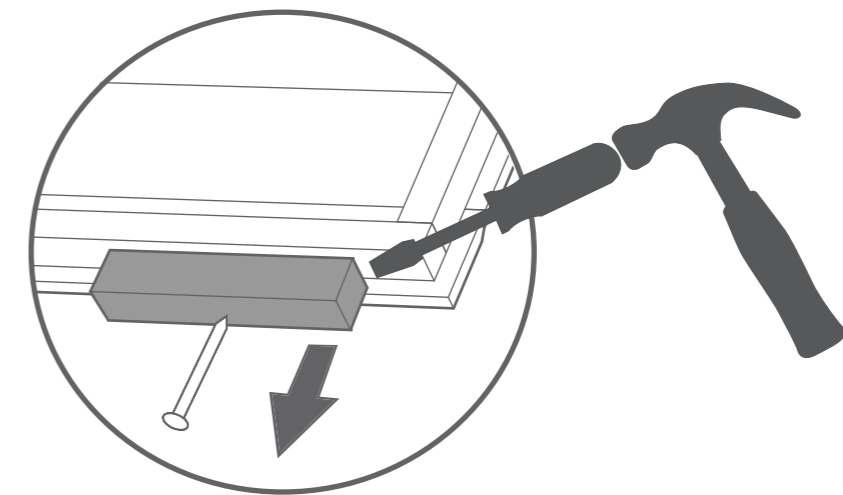

Nail Bag

There may be extra screws present in the nail bag

- | | | | |
|--|------------------------|--|-------------------------|
| | 100mm Screw x 2 | | 30mm Screw x 283 |
| | 60mm Bolt x 8 | | 20mm Screw x 9 |
| | 60mm Screw x 8 | | 16mm Screw x 24 |
| | 50mm Screw x 91 | | Felt Tacks x 125 |
| | 40mm Screw x 40 | | |

Step 1

Parts Needed- No.1 QTY 4

Place the floor panels (**No.1**) onto a firm and level base. Ensure the base has suitable drainage, free from areas where standing water can collect.

Secure the floors together using 8x50mm screws through the floor bearers in an alternating pattern.

Repeat the step to create two floor assemblies.

16x50mm Screws

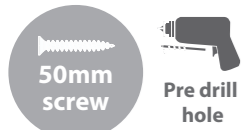

IMPORTANT: Pre-drill before fixing screws.

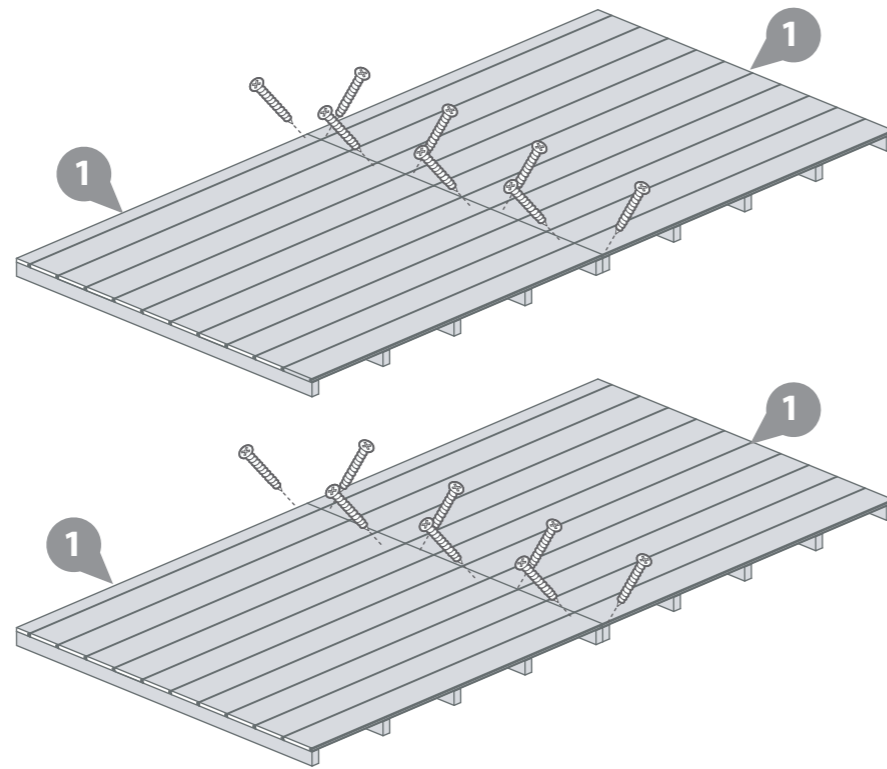

Step 2

Parts Needed- No.14 QTY 8

Locate the Floor Blocks (**No.14**) between the floor framing, ensuring they are spaced equally.

Secure to the floor using 2x40mm screws per block, going through the floor cladding and into the floor blocks below.

16x40mm Screws



IMPORTANT: Pre-drill before fixing screws.

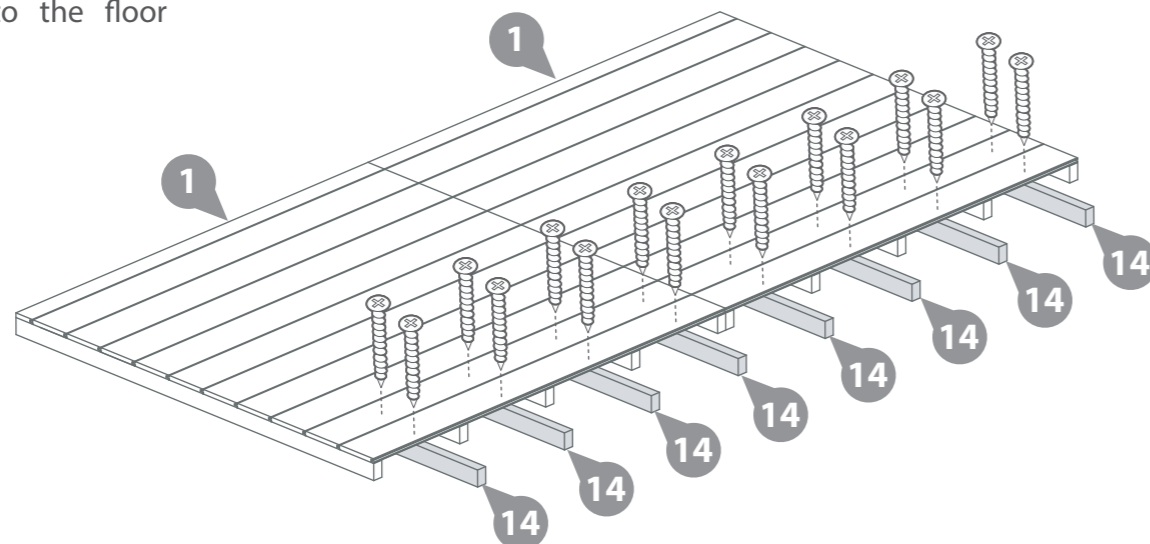

Step 3

Locate the second floor assembly along side the first floor assembly.

Secure to the floor using 2x40mm screws per block, going through the floor cladding and into the floor blocks below.

16x40mm Screws



IMPORTANT: Pre-drill before fixing screws.

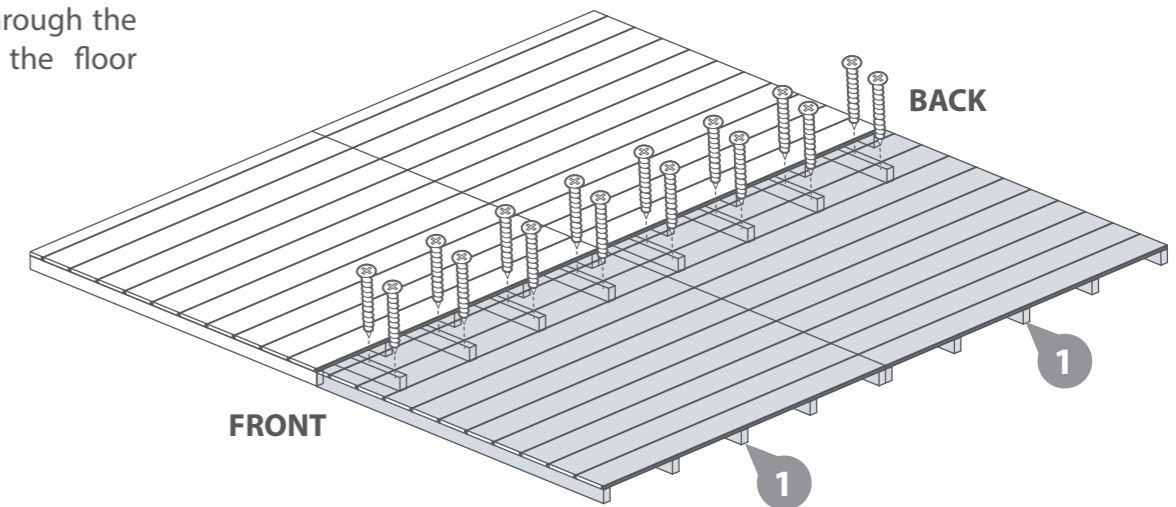

Step 4

Parts Needed- No.2 QTY 1
- No.3 (or 4) QTY 1

****Please note: The side panels are interchangeable. Decide which layout works best for you before assembly.****

Locate the Back Panel (**No.2**) and the Side panel (**No.3**) (or Window Panel) onto the floor, ensuring there is equal spacing.

Secure the panels together at the corner using 3x50mm screws.

Do not secure the building to the floor until the roof is fitted.

****Please note: The Side Panels are slightly higher than the back panels.****

3x50mm Screws

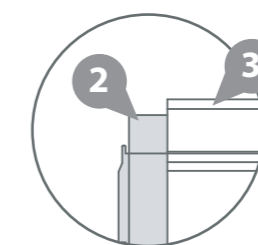
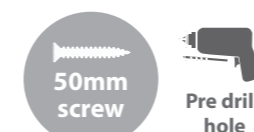

IMPORTANT: Pre-drill before fixing screws.

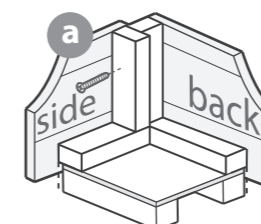
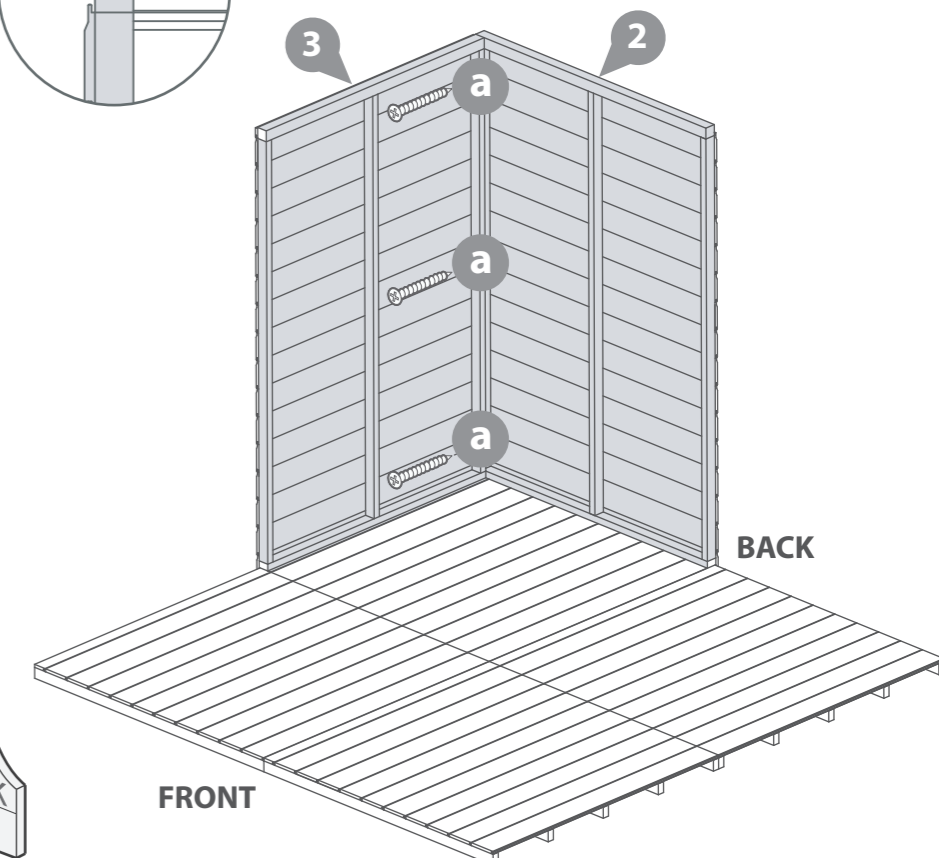

Step 5

Parts Needed- No.2 QTY 1
- No.3 (or 4) QTY 1

Locate the Second Back Panel (No.2) and Side panel (No.3) (or Window Panel) onto the floor, ensuring there is equal spacing.

Secure the panels together at the joins using 3x50mm screws per join in an alternating pattern.

Do not secure the building to the floor until the roof is fitted.

****Please note: The Side Panels are slightly higher than the back panels.****

6x50mm Screws

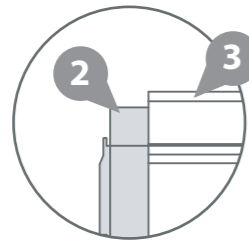
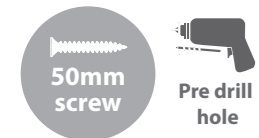

IMPORTANT: Pre-drill before fixing screws.

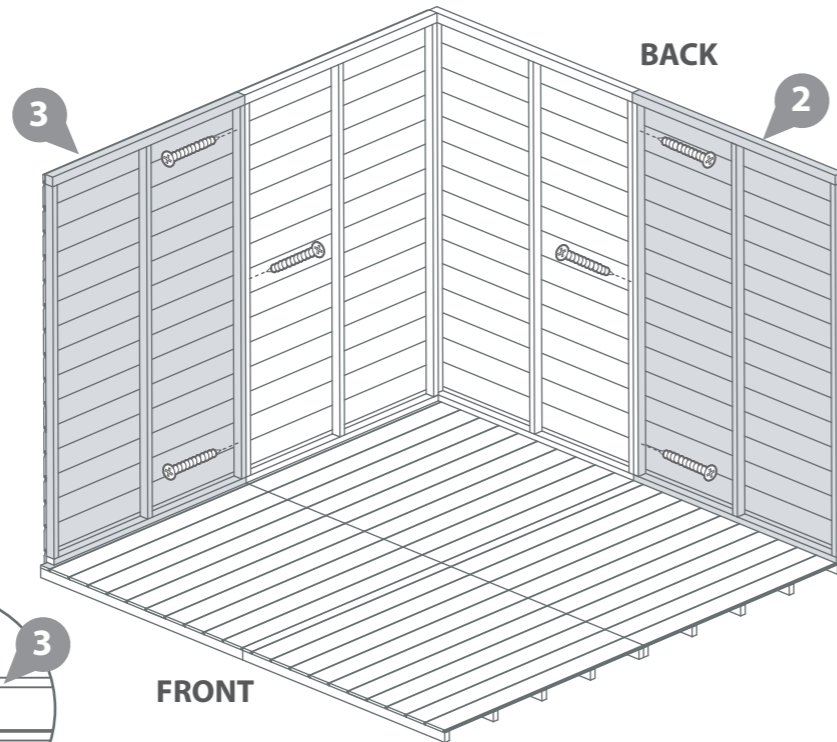

Step 7

Parts Needed- No.4 (or 3) QTY 1

Locate the Second Window Panel (No.4) (or Side Panel) onto the floor, ensuring there is equal spacing.

Secure the panels together at the joins using 3x50mm screws per join in an alternating pattern.

Do not secure the building to the floor until the roof is fitted.

****Please note: The Side Panels are slightly higher than the back panels.****

3x50mm Screws

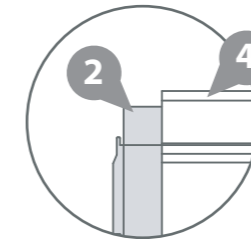

IMPORTANT: Pre-drill before fixing screws.

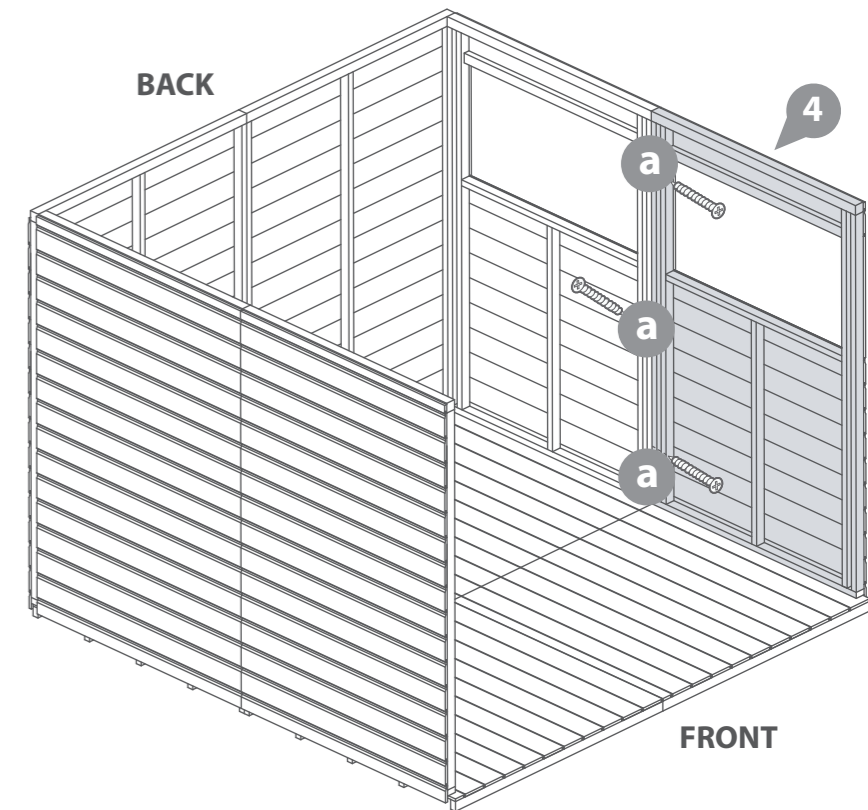

Step 6

Parts Needed- No.4 (or 3) QTY 1

Locate the Window Panel (No.4) (or Side Panel) onto the floor, ensuring there is equal spacing.

Secure the panels together at the corner using 3x50mm screws.

Do not secure the building to the floor until the roof is fitted.

****Please note: The Side Panels are slightly higher than the back panels.****

3x50mm Screws

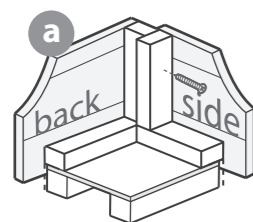
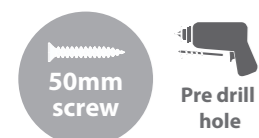

IMPORTANT: Pre-drill before fixing screws.

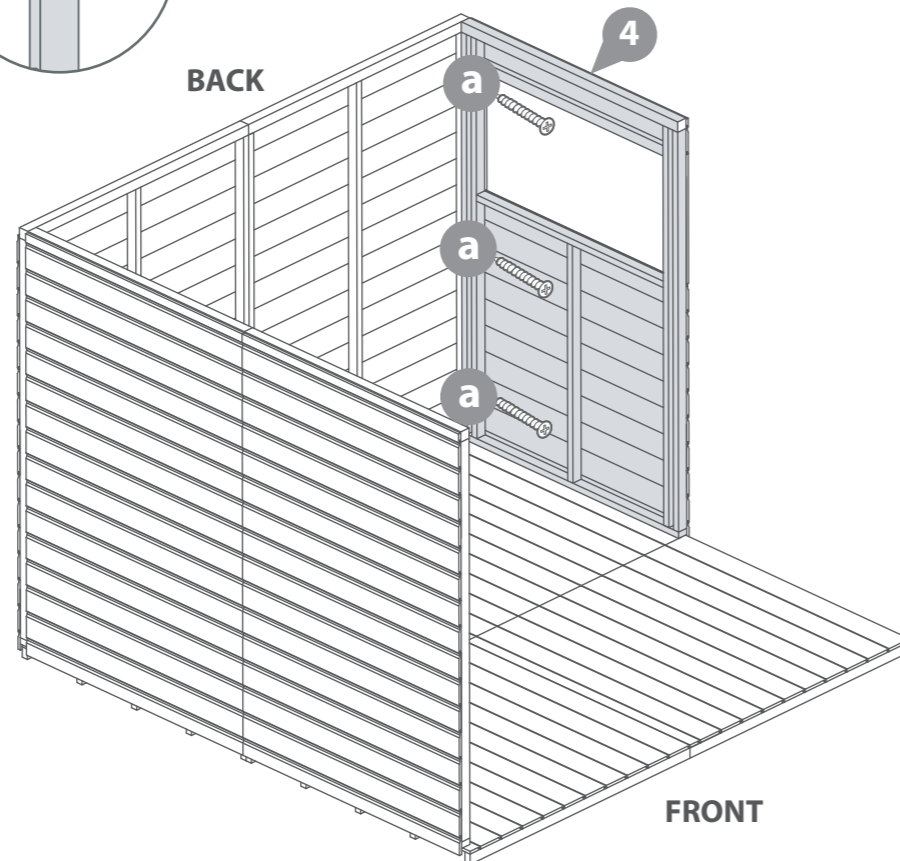
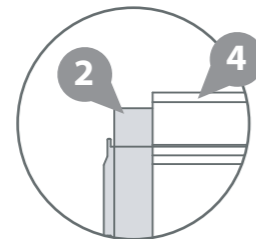

Step 8

Parts Needed- No.6 QTY 2

Locate the Front Panels (No.6) onto the floor, ensuring there is equal spacing.

Secure the panels at the corners using 3x50mm screws.

Do not secure the building to the floor until the roof is fitted.

****Please note: The Front Panels are slightly lower than the side panels.****

6x50mm Screws

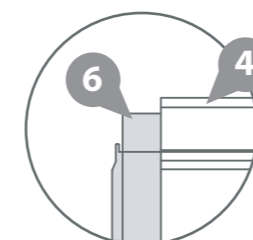
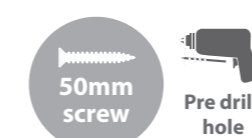

IMPORTANT: Pre-drill before fixing screws.

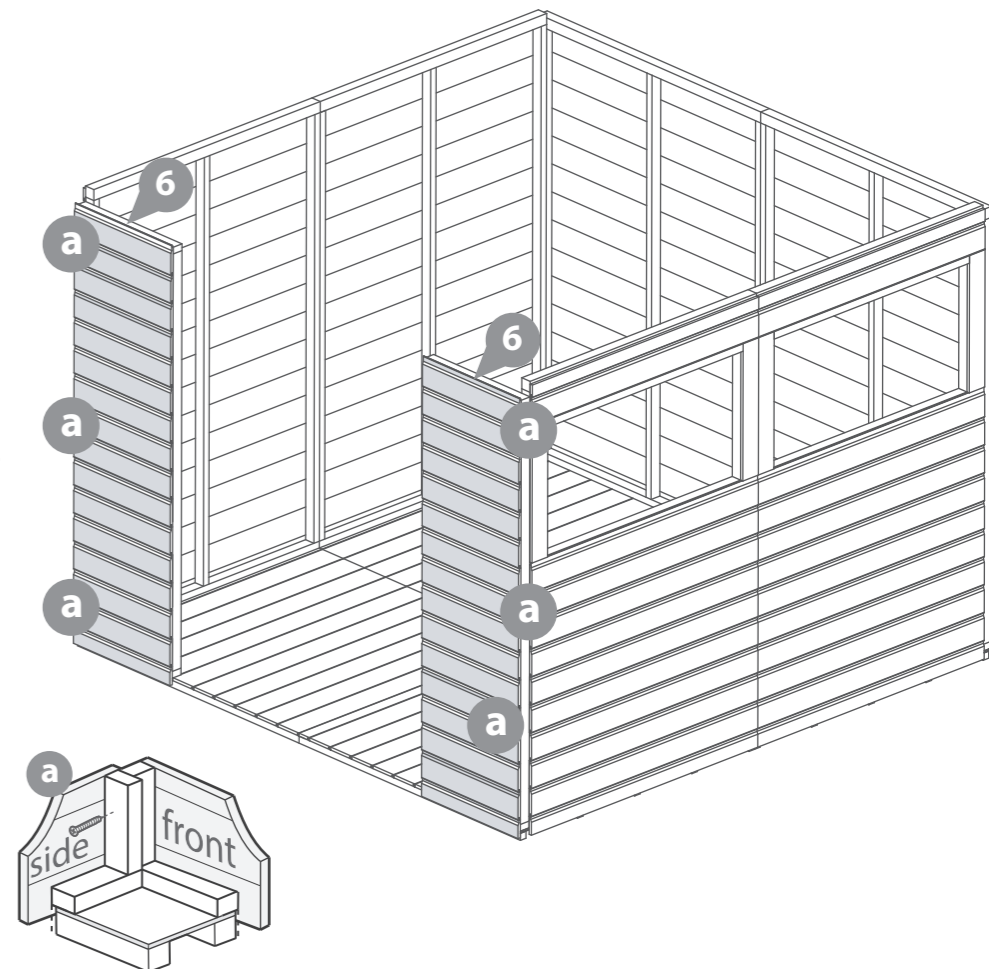

Step 9

Parts Needed- No.21 QTY 2
 - No.22 QTY 1
 - No.23 QTY 1

Locate the Top Door Framing (No.21 & 22) onto the top of the front panels. The framing should be flush to the back edges of the framing within front panels.

Secure the framing using 8x60mm screws, ensuring to go through the Top Door Framing, and into the Front Panel framing.

Locate the Bottom Door Framing (No.23) between the front panel. Do Not secure the Bottom Door Framing to the floor until the roof is fitted.

****Please note: The Front Panels are slightly lower than the side panels.****

8x60mm Screws

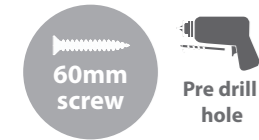

IMPORTANT: Pre-drill before fixing screws.

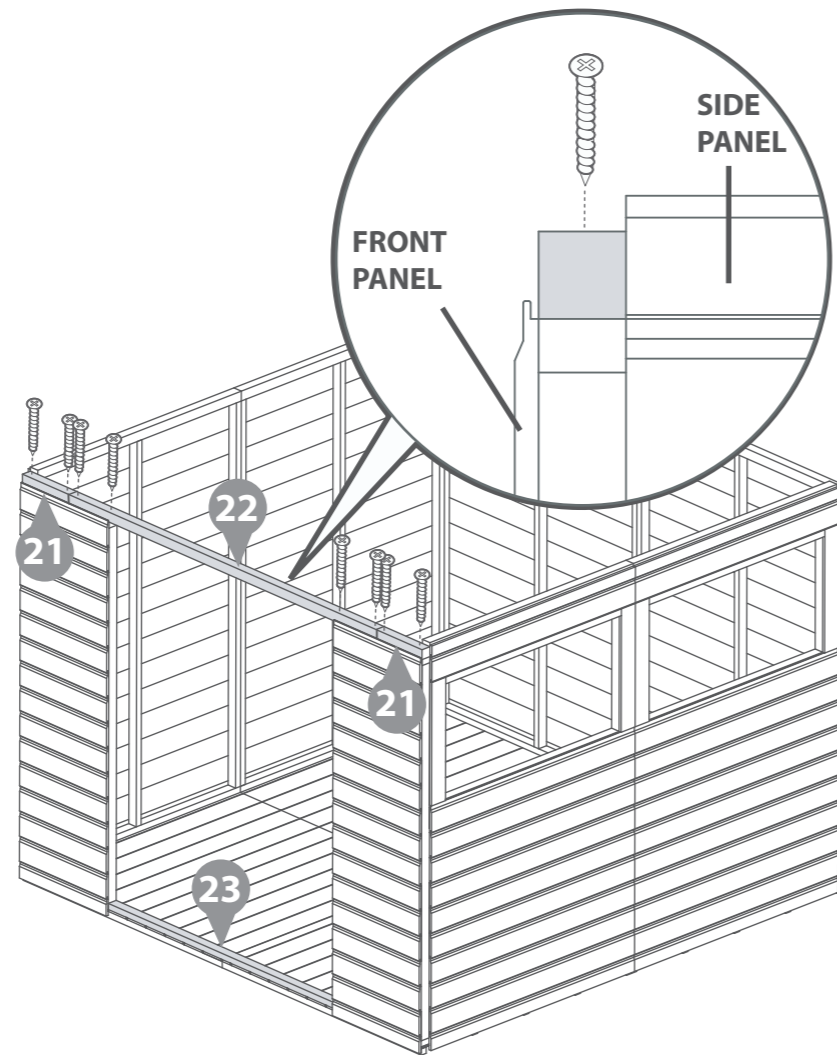

Step 10

Parts Needed- No.7 QTY 2
 - No.8 QTY 2

Lay the Gable tops (No.7 & 8) along side each other, ensure they are flush at the bottom. Secure together using 4x50mm screws in an alternating pattern.

Repeat step to create a second assembly.

8x50mm Screws

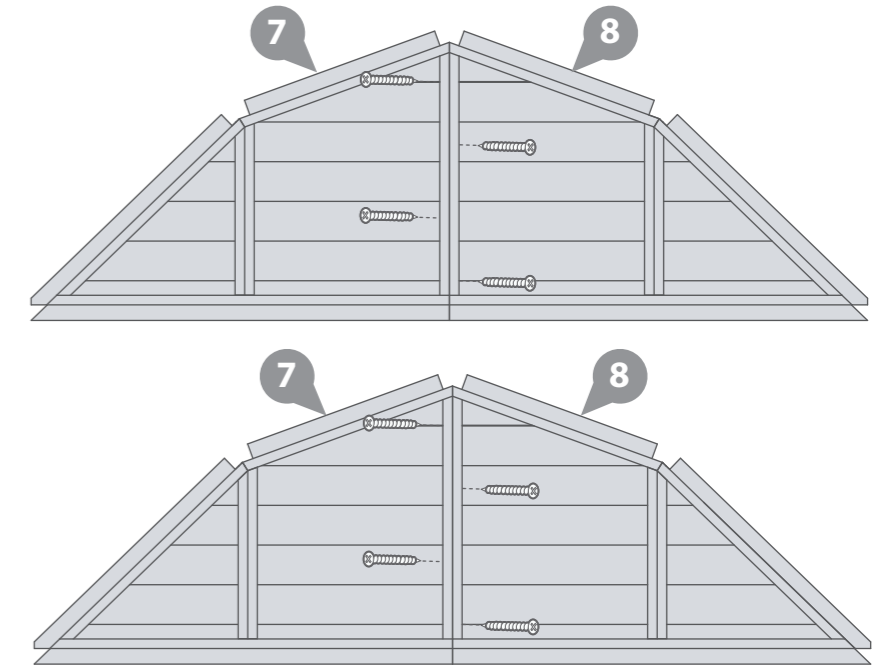
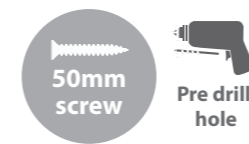

Step 11

Locate the assembled Gable tops (No.7 & 8) onto the top of the front and back panels ensuring to slot the groove of the boarding within the Gable Tops on to the tongues within the plain panels below.

Secure the assembled Gable Tops from above using 6x50mm screws per gable top.

Make sure the gable tops are flush with the ends of the panels as shown in the diagram.

Do not secure the building to the floor until the roof is fitted.

12x50mm Screws

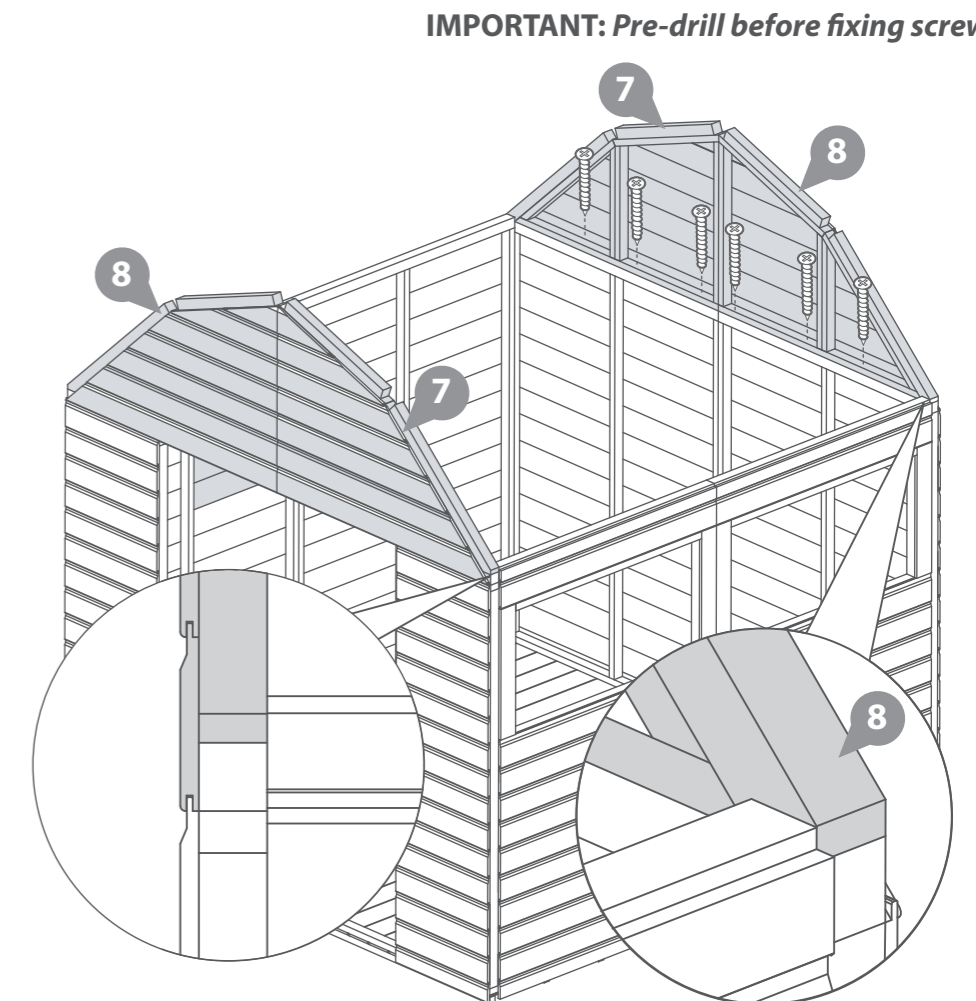

IMPORTANT: Pre-drill before fixing screws.

Step 12

Parts Needed- No.28 QTY 2

Locate the Gable Strips (**No.28**) onto the join of the Gable Tops and front/back panels.

Secure the Gable Strips (**No.28**) using 4x30mm screws per strip in an alternating pattern. Do not fix into the gap between the panels.

8x30mm Screws

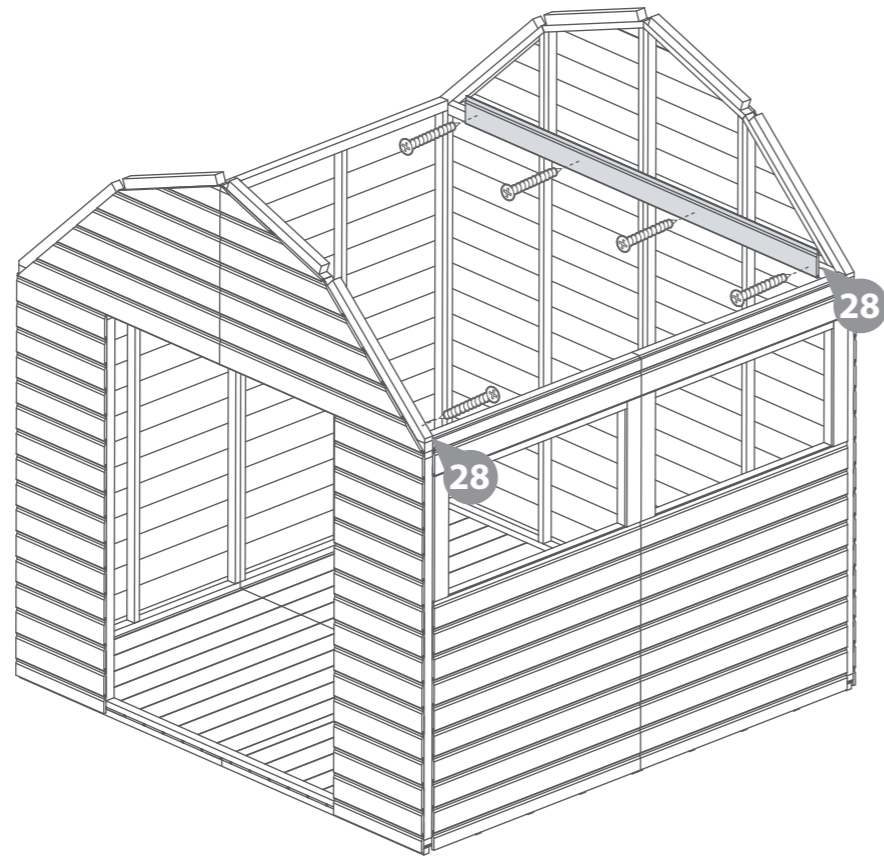
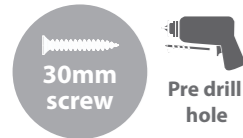

IMPORTANT: Pre-drill before fixing screws.

Step 14

Parts Needed- No.31 QTY 2

Measure and mark 42mm from the top corner of the truss.

Place the Truss in position with a 42mm gap from the top corner of the truss to the top of the side panel.

Locate the Truss Blocks (**No.31**) onto each side of the building, then use the measurement made when together with the truss to determine the height of the Truss blocks and mark the position.

Secure the truss blocks in an alternating pattern using 2x50mm screws per block, ensuring to go through to the panel framing behind. Do not fix into the gap between the panels.

Fix the truss to the side panels using 1x50mm screw per side making sure that you go into the panel framing behind.

Fix a further 100mm screw to each side from the exterior of the building into the truss on the inside.

6x50mm Screws
2x100mm Screws

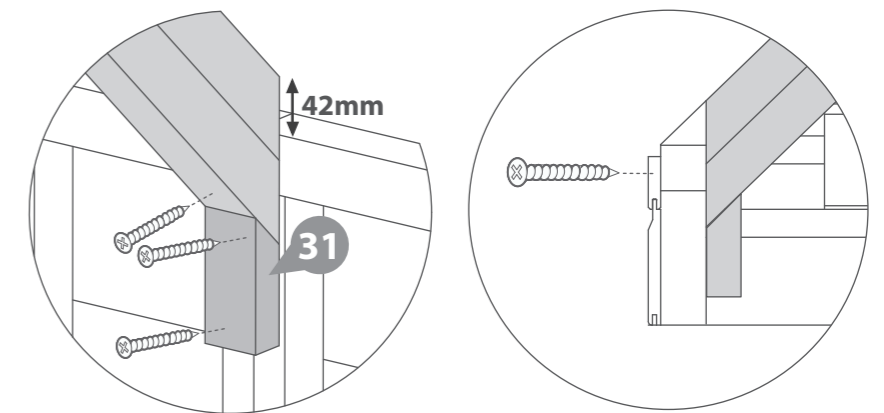

Step 13

Parts Needed- No.9 QTY 2

- No.10 QTY 2
- No.29 QTY 2
- No.41 QTY 6

a Place all of the required parts together on the floor in the correct layout as shown in the illustration. Secure the Joining plates (**No.41**) to both sides of the truss along the framing joints with 5x30mm screws per plate, ensuring the screws are staggered to avoid collision.

b Secure the Truss Brace (**No.29**) to both sides of the Lower Trusses, making sure to stagger the 4x40mm screws at each end. The truss brace should finish flush with the edge of the lower truss.

30x30mm Screws
8x40mm Screws

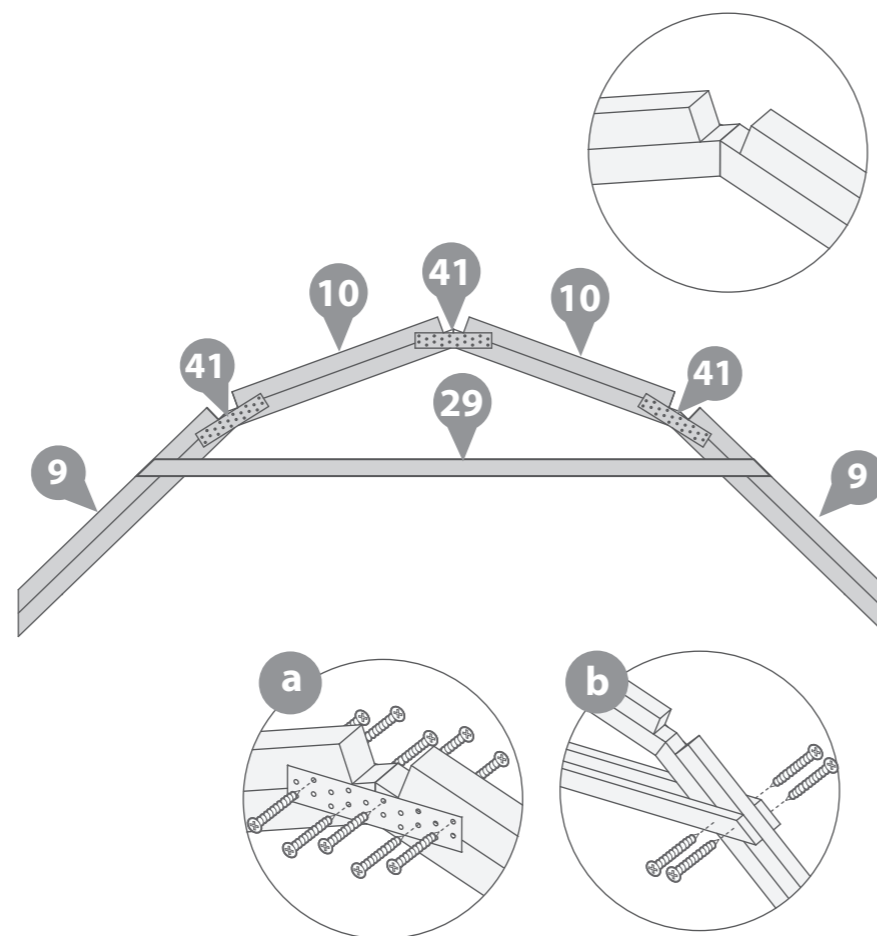
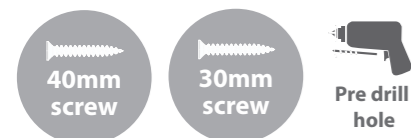

IMPORTANT: Pre-drill before fixing screws.

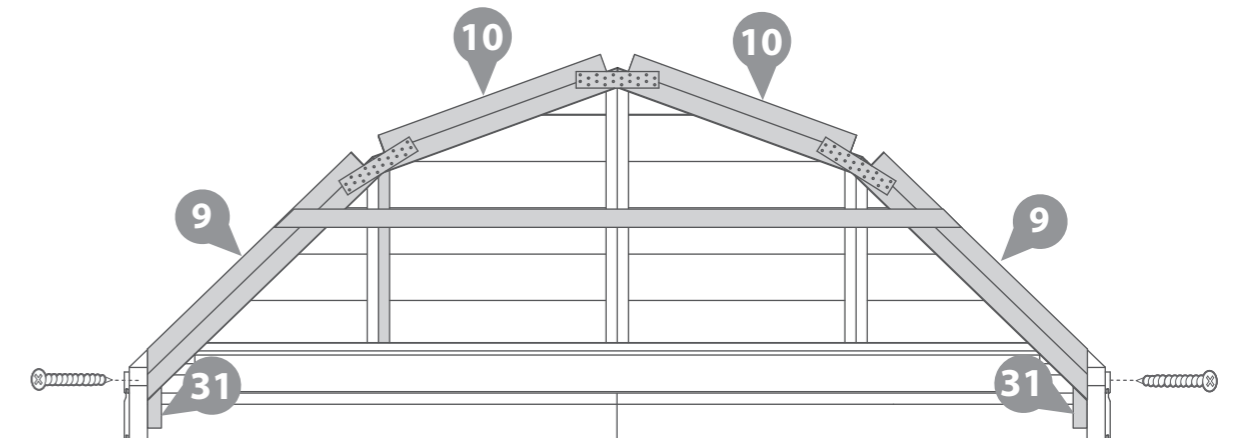

Step 15

Parts Needed- No.12 QTY 4
- No.40 QTY 2

Locate the Bottom roof panels (No.12) and secure the roof panels together using a U channel (No.40) on to the top framing pieces. Ensure the U channel (No.40) is equally spaced over the roof panel framing. Secure the U channels using 10x30mm screws per channel.

Repeat the step to create a second assembly.

20x30mm Screws

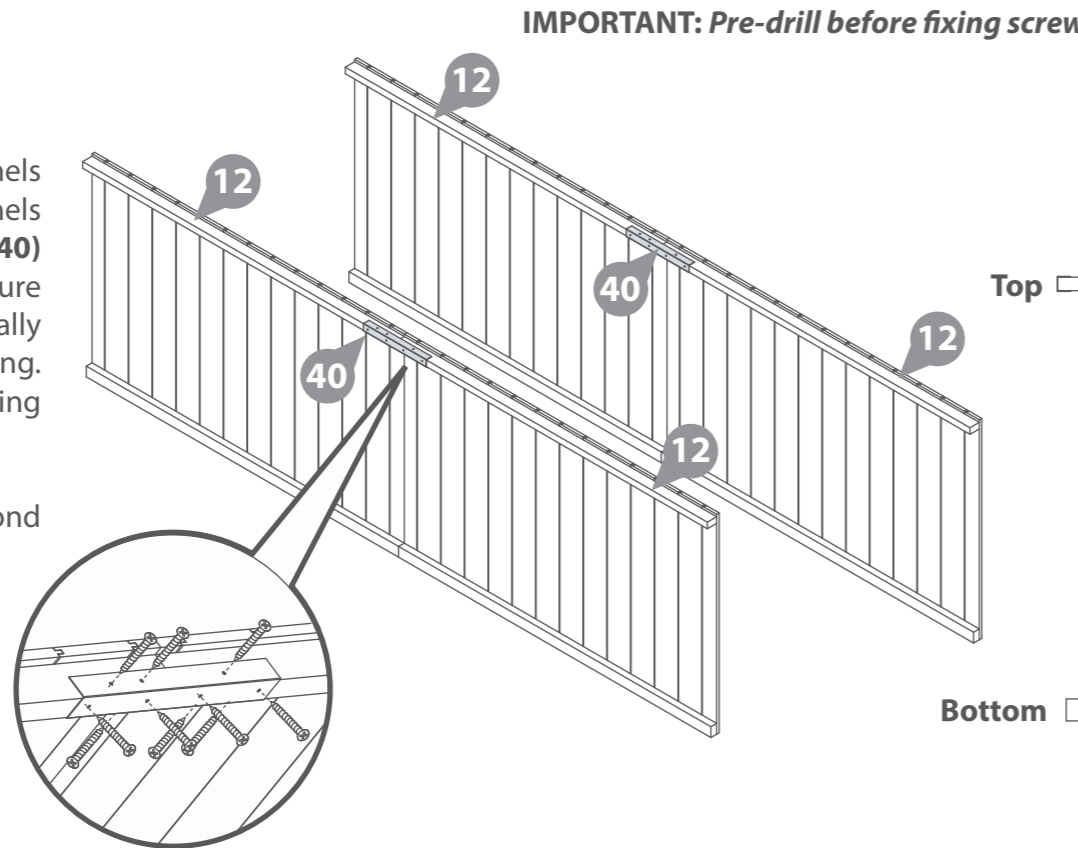
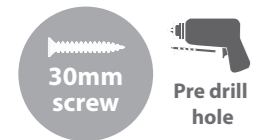

Step 16

Parts Needed- No.11 QTY 4
- No.40 QTY 2

Locate the Top roof panels (No.11) and secure the roof panels together using a U channel (No.40) on to the top framing pieces.

Make sure that the U channel is on the framing within the roof panel where there is a 16mm gap between the top of the framing and the edge of the roof cladding. Ensure the U channel (No.40) is equally spaced over the roof panel framing. Secure the U channels using 10x30mm screws per channel.

Repeat the step to create a second assembly.

20x30mm Screws

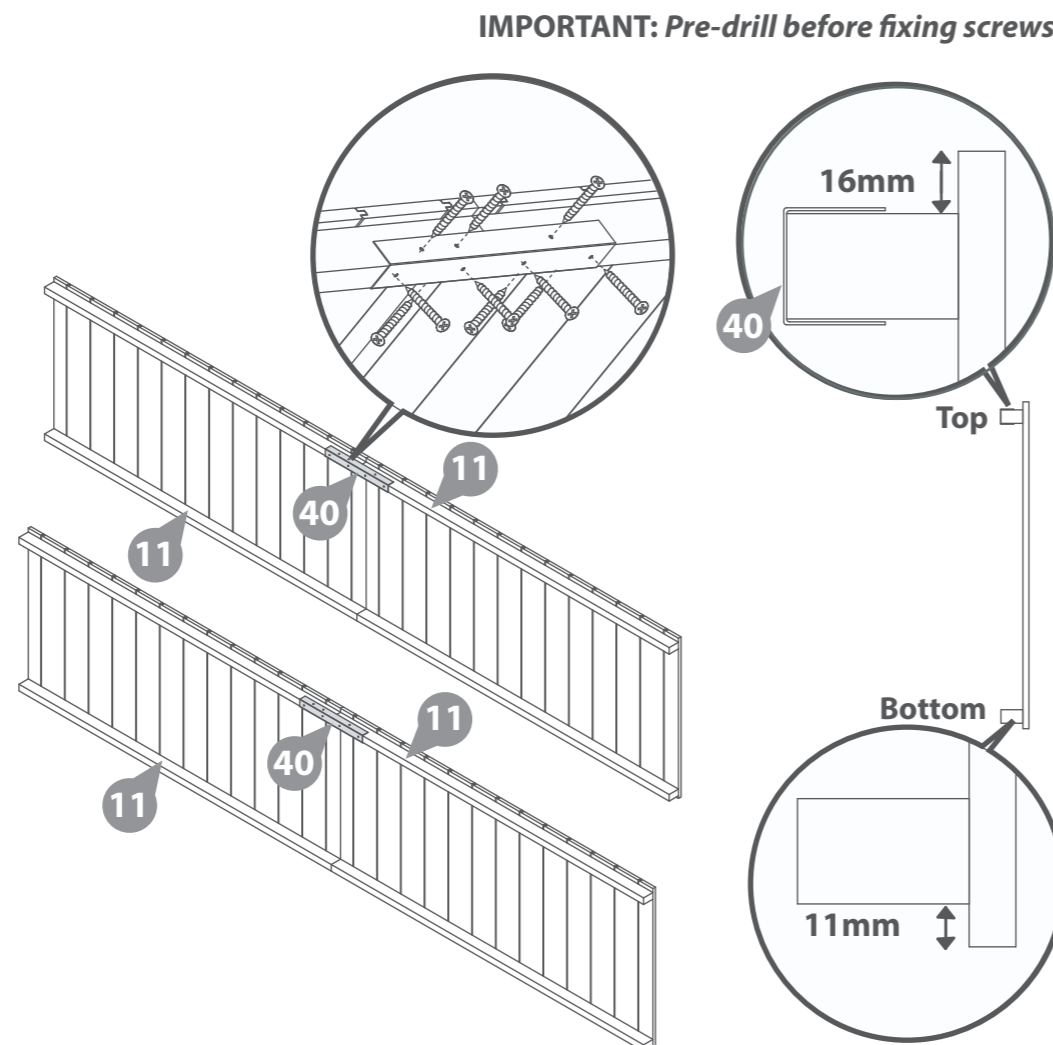
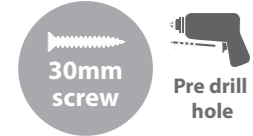

Step 17

Parts Needed- No.12 QTY 4

Place the Bottom roof panels (No.12) on top of the gables and truss, ensuring they are correctly orientated with the U channel slotted into the roof truss.

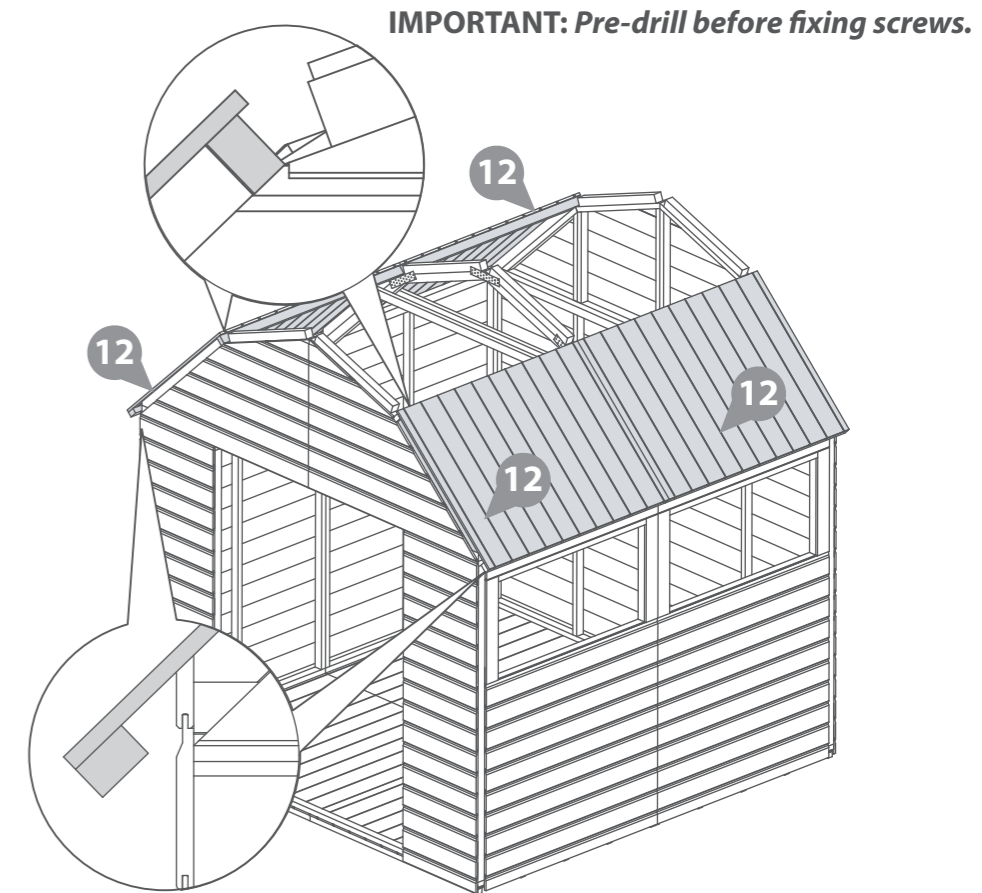

Step 18

Secure the Roofs using 4x30mm screws per roof, ensuring to go through the roof cladding and into the gable top framing and the truss framing below.

Position the panels so there is equal spacing.

****Make sure that the edges of the framing within the roof panels are flush with the outer cladding on the front and back panels.****

Do not secure the building to the floor until the roof is fitted.

16x30mm Screws

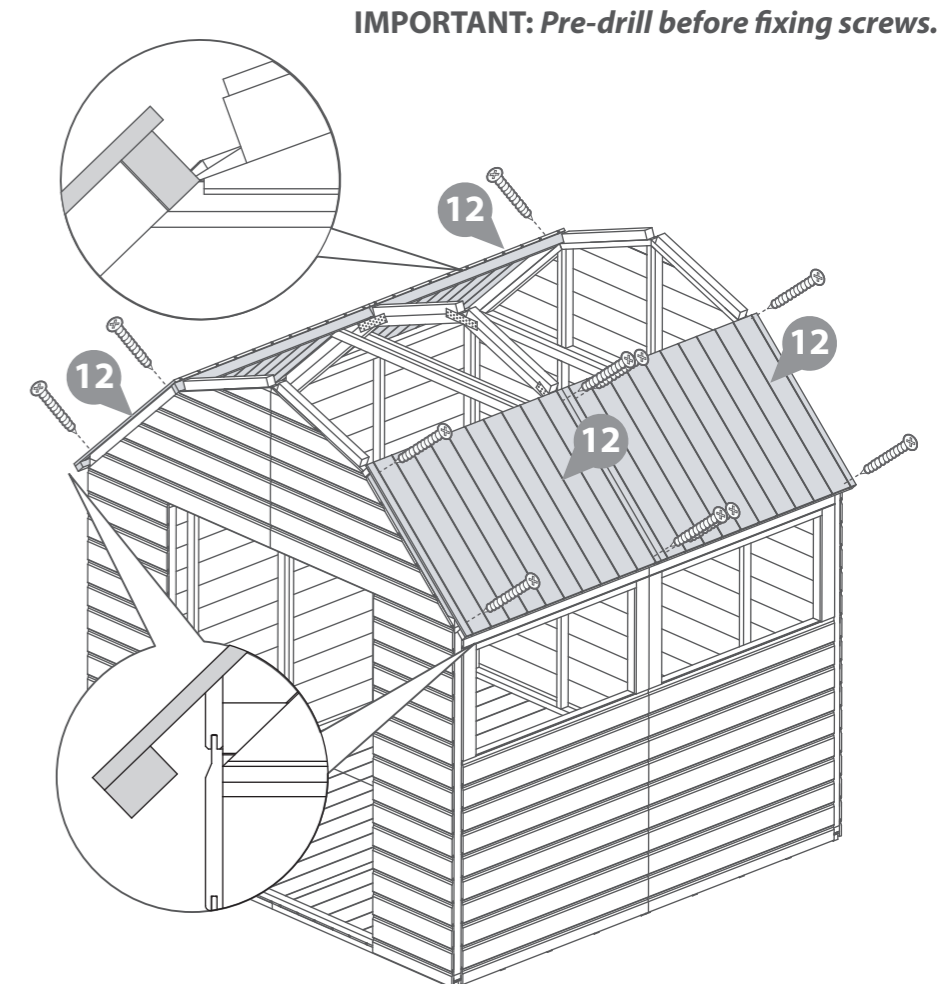

Step 19

Parts Needed- No.11 QTY 4

Place the Top Roof Panels (No.11) on top of the gables and truss, ensuring they are correctly orientated with the U channel slotted into the top of the roof truss.

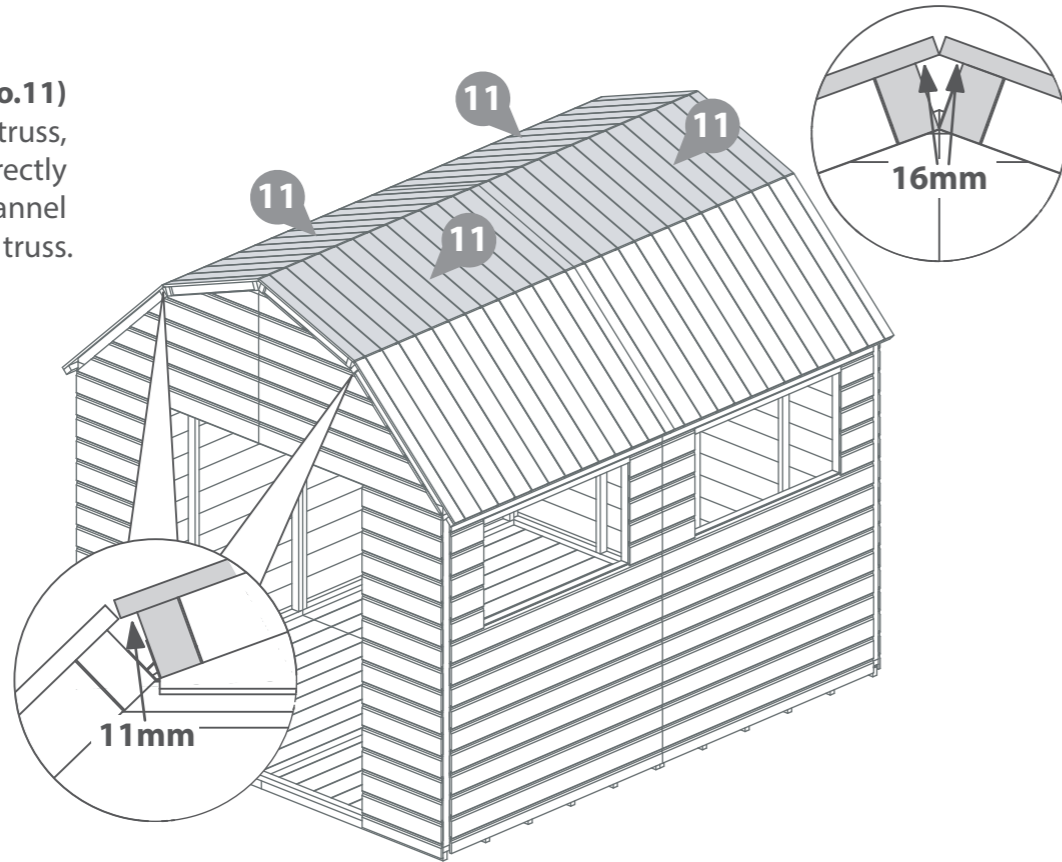

IMPORTANT: Pre-drill before fixing screws.

Step 21

Further secure each Roof in place using 4x30mm screws, ensuring they are no more than 300mm apart. Make sure to screw through the cladding into the framing below.

Do not secure the building to the floor until the roof is fitted.

32x30mm Screws

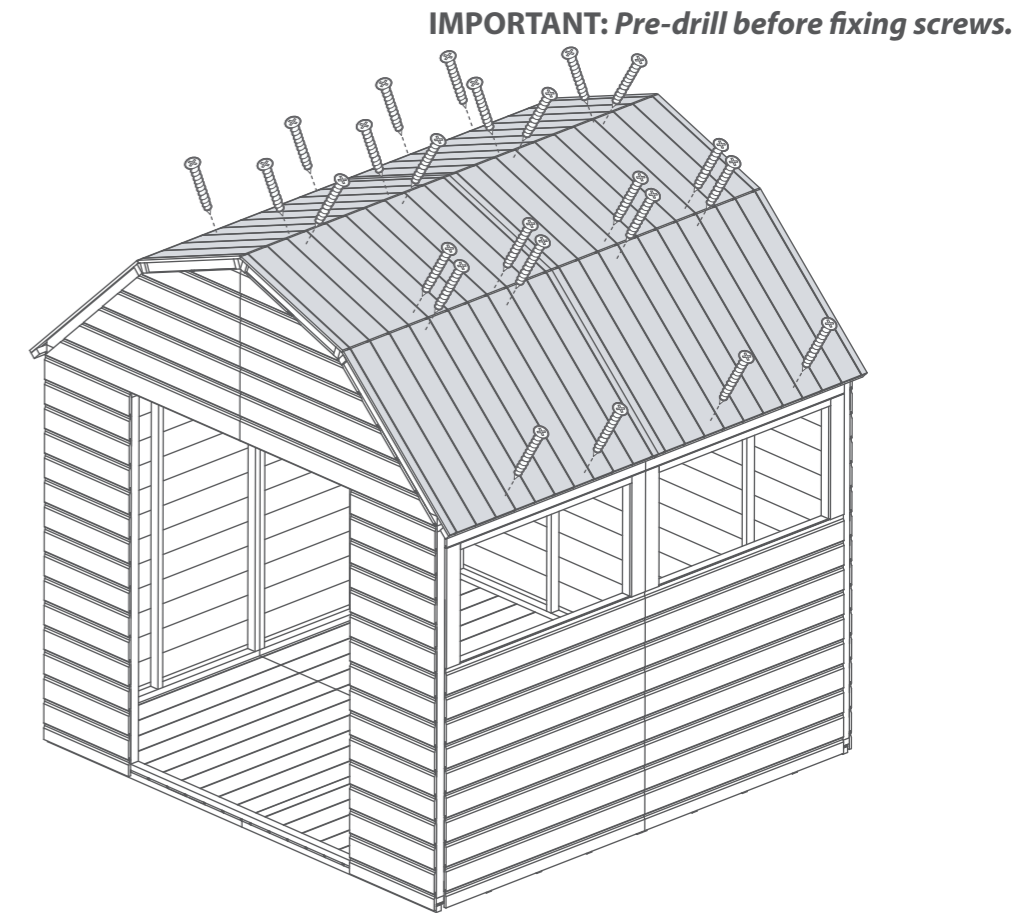
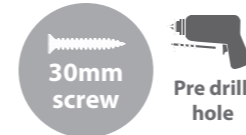

IMPORTANT: Pre-drill before fixing screws.

Step 20

Secure the Roofs using 4x30mm screws per roof, ensuring to go through the roof cladding and into the gable top framing and the truss framing below.

Position the panels so there is equal spacing.

****Make sure that the edges of the framing within the roof panels are flush with the outer cladding on the front and back panels.****

Do not secure the building to the floor until the roof is fitted.

16x30mm Screws

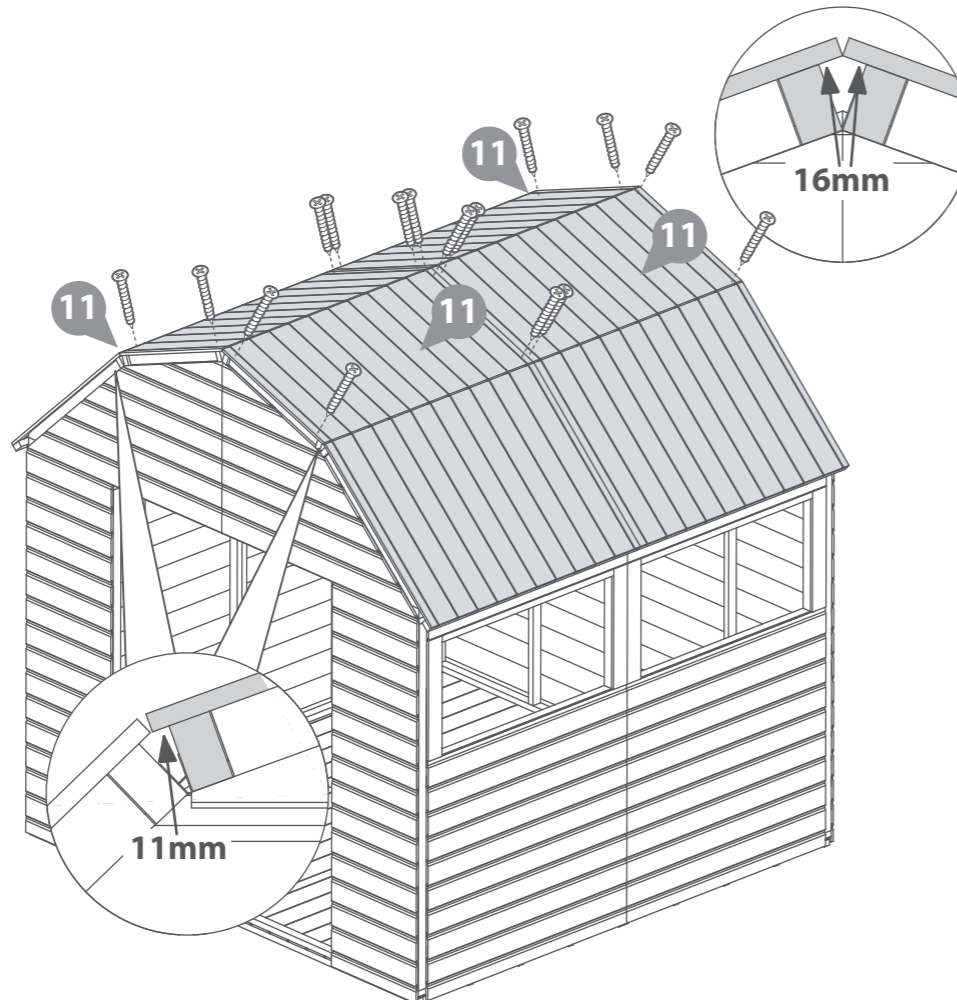
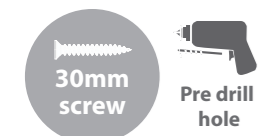

IMPORTANT: Pre-drill before fixing screws.

Step 22

Once the roof is fixed, secure the building to the Floor with 50mm screws.

Ensure the screws go through the panel into the Floor framing.

24x50mm Screws

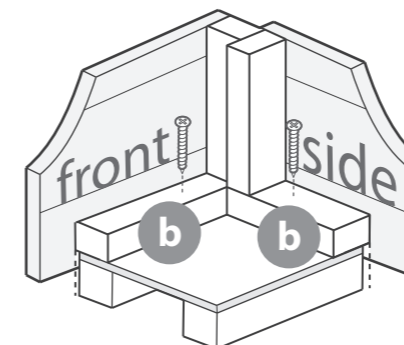

IMPORTANT: Pre-drill before fixing screws.

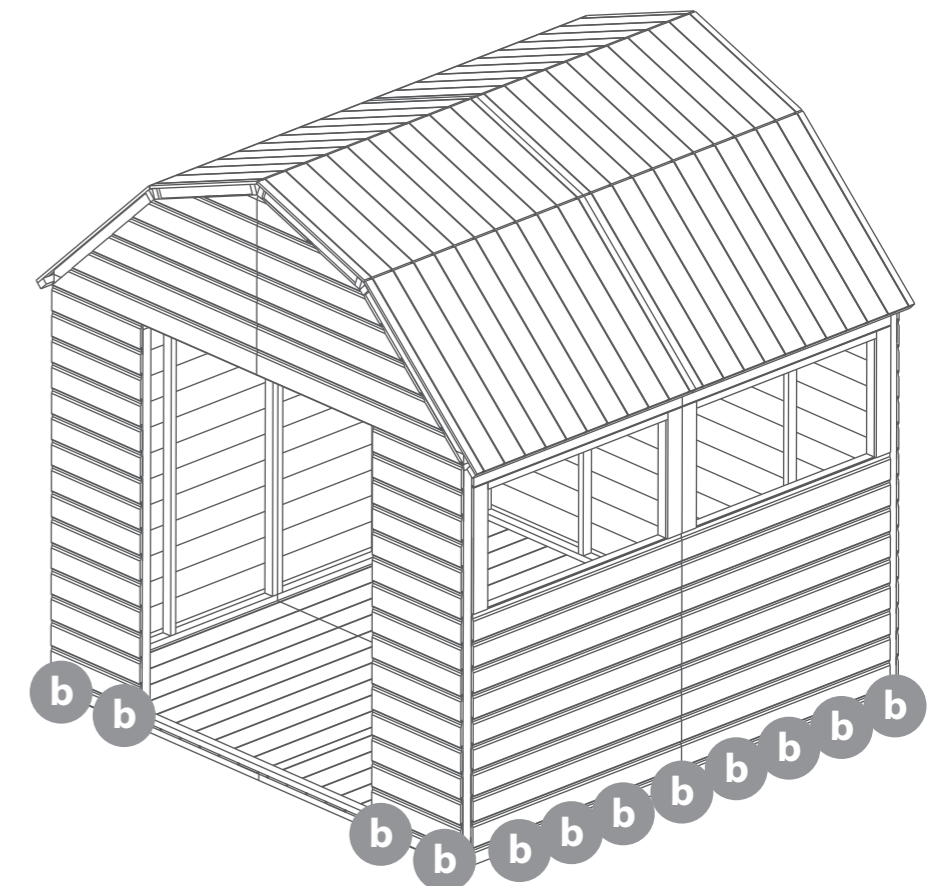

Step 23

Make sure that the Bottom Door Framing (No.23) is flush with the framing within the front panels. Fix the Bottom Door Framing to the floor ensuring that you go into the framing below.

4x50mm Screws

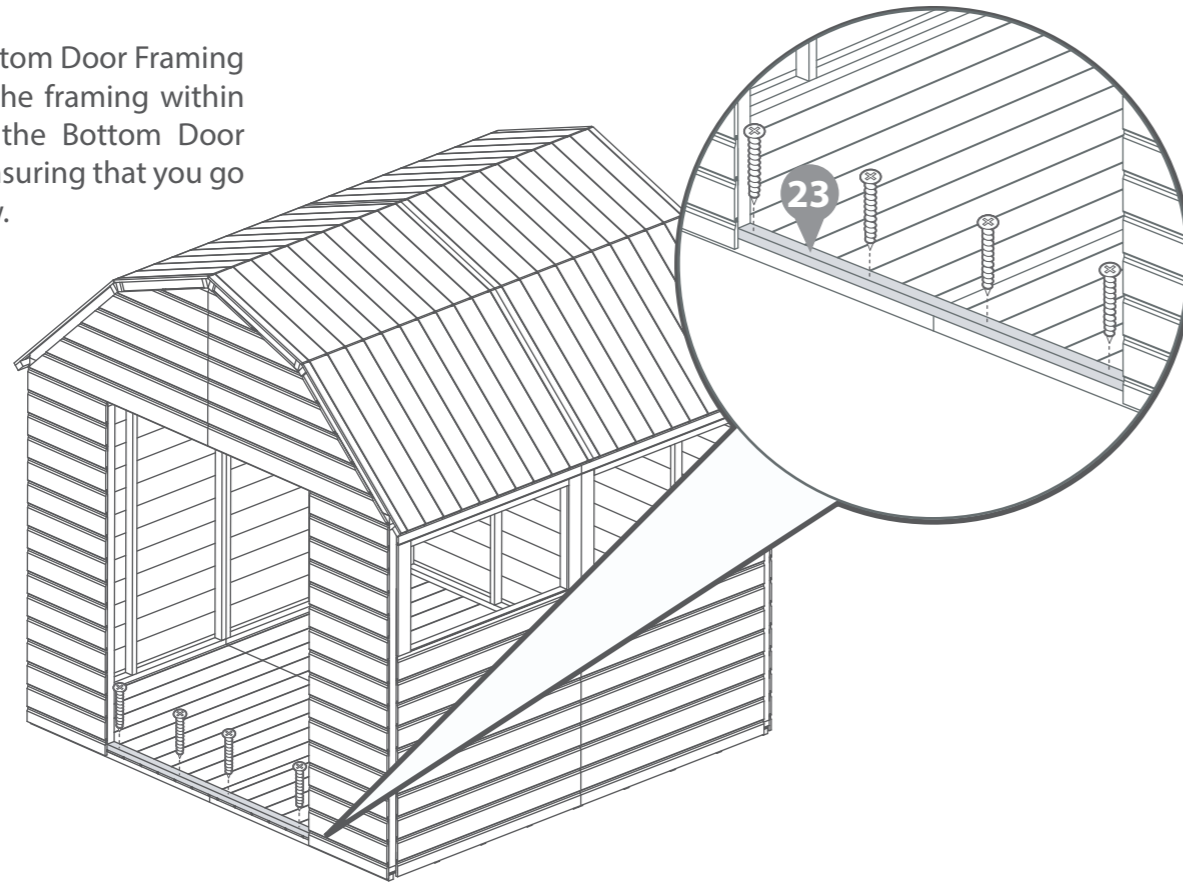
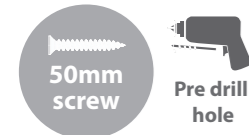

IMPORTANT: Pre-drill before fixing screws.

Step 24

Parts Needed- No.16 QTY 1
- No.17 QTY 2

Locate the Door Strips (No.16 & 17) around the door opening and ensure that they are flush with the framing.

There should be a gap between the strips and the door opening as shown.

Secure each strip with 4x30mm screws, going through the strips and into the door panel cladding.

12x30mm Screws

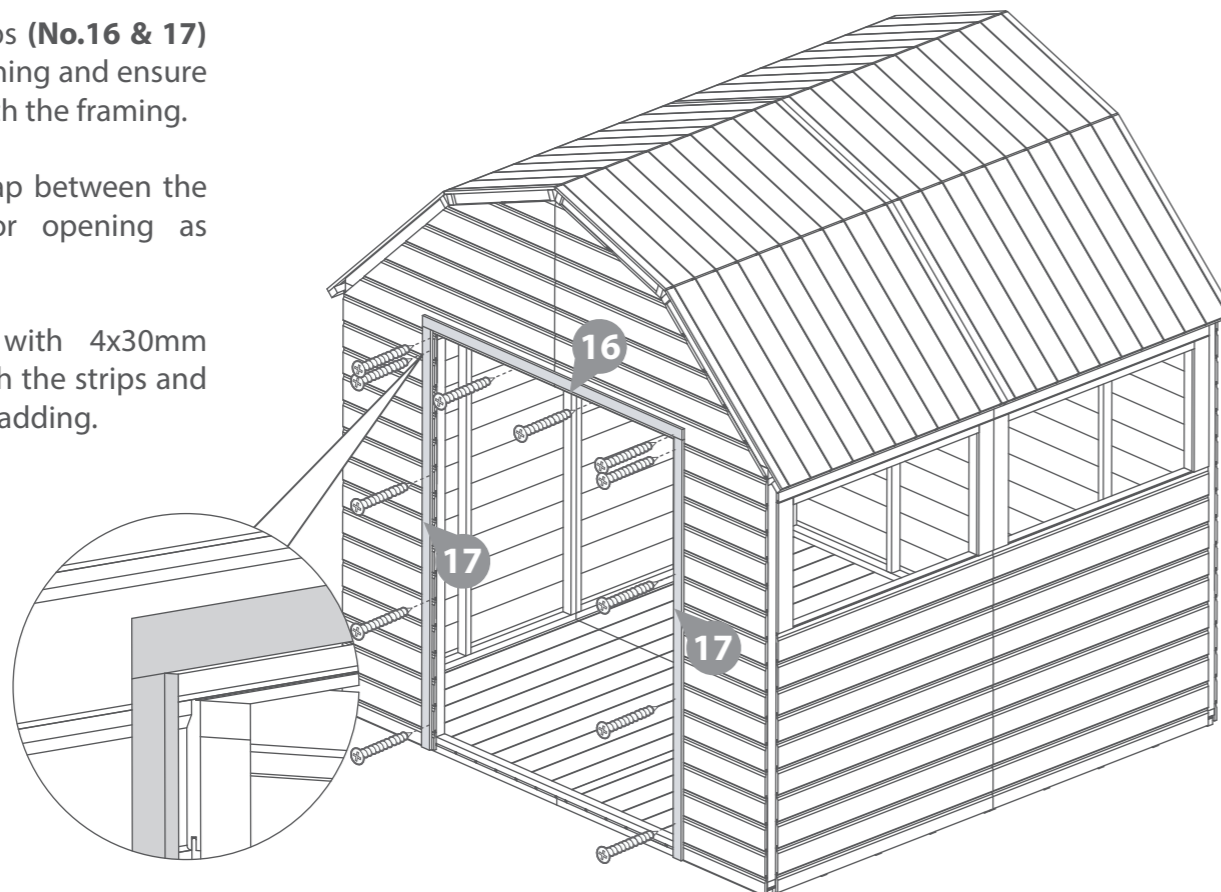
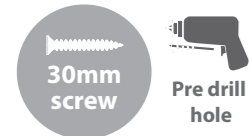

IMPORTANT: Pre-drill before fixing screws.

Step 25

Parts Needed- No.5 QTY 2
- No.33 QTY 6

Fix 3 Hinges (No.33) to each Door (No.5) securing with 4x30mm screws per hinge and position as shown.

Fix each Door to the building with 3x30mm screws per hinge. Make sure that the inside view of the door looks like it does on the illustration.

Ensure the doors open and close freely.

42x30mm Screws

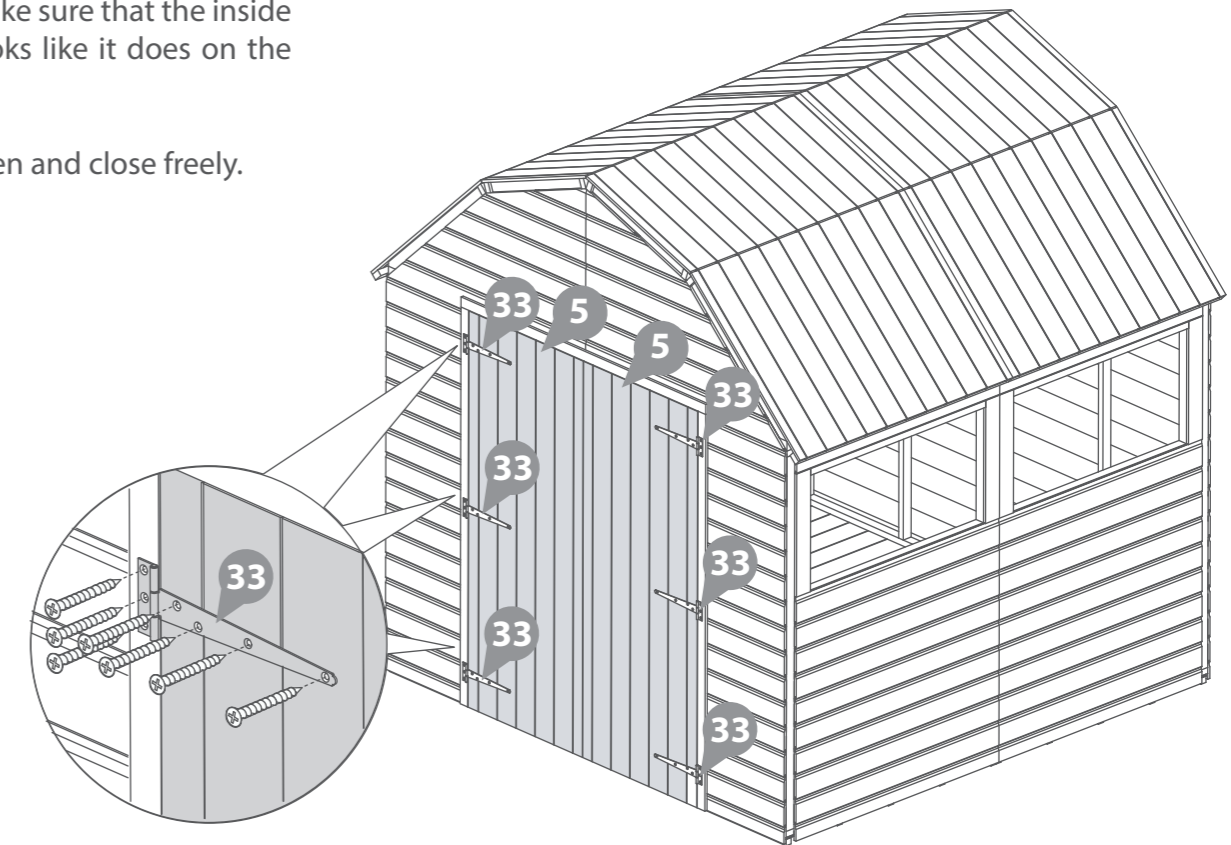
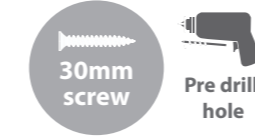

IMPORTANT: Pre-drill before fixing screws.

PLEASE SCAN HERE:



Inside View

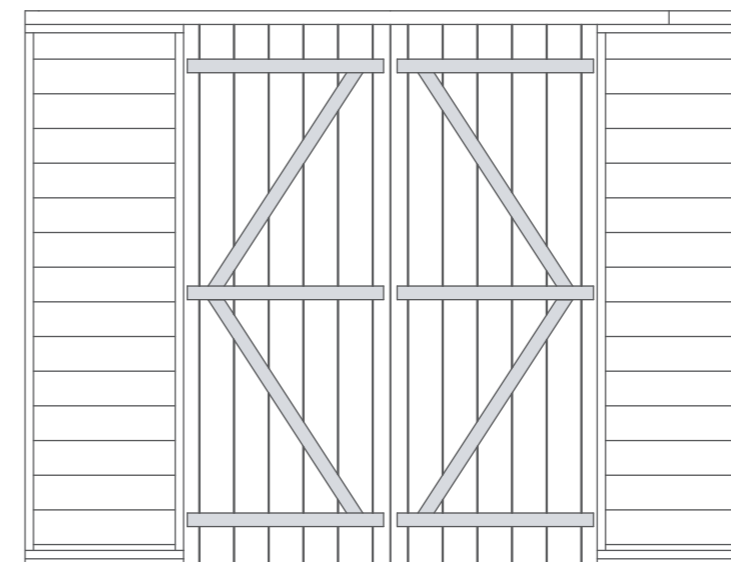

SECONDARY PRIMARY

Step 26

Parts Needed- No.15 QTY 1
- No.30 QTY 2

Place the Door Blocks (No.30) onto the top of the door framing and ensure that they are flush with the ends of the framing. Secure using 2x30mm screws per block, going through the front of the door cladding and into the door block.

Locate the Door Cloaking Strip (No.15) between the door framing and ensure that it is equally spaced. Secure to the secondary door using 4x30mm screws, going through the front of the door cladding and into the Door Cloaking Strip.

8x30mm Screws



Step 27

Parts Needed- No.34 QTY 2

Align the tower bolts (No.34) onto the door cloaking strip, secure the bolts to the top and bottom using 6x30mm screws per tower bolt.

Mark the position of the bolt & drill a hole above and below for the bolt to catch in to.

12x30mm Screws

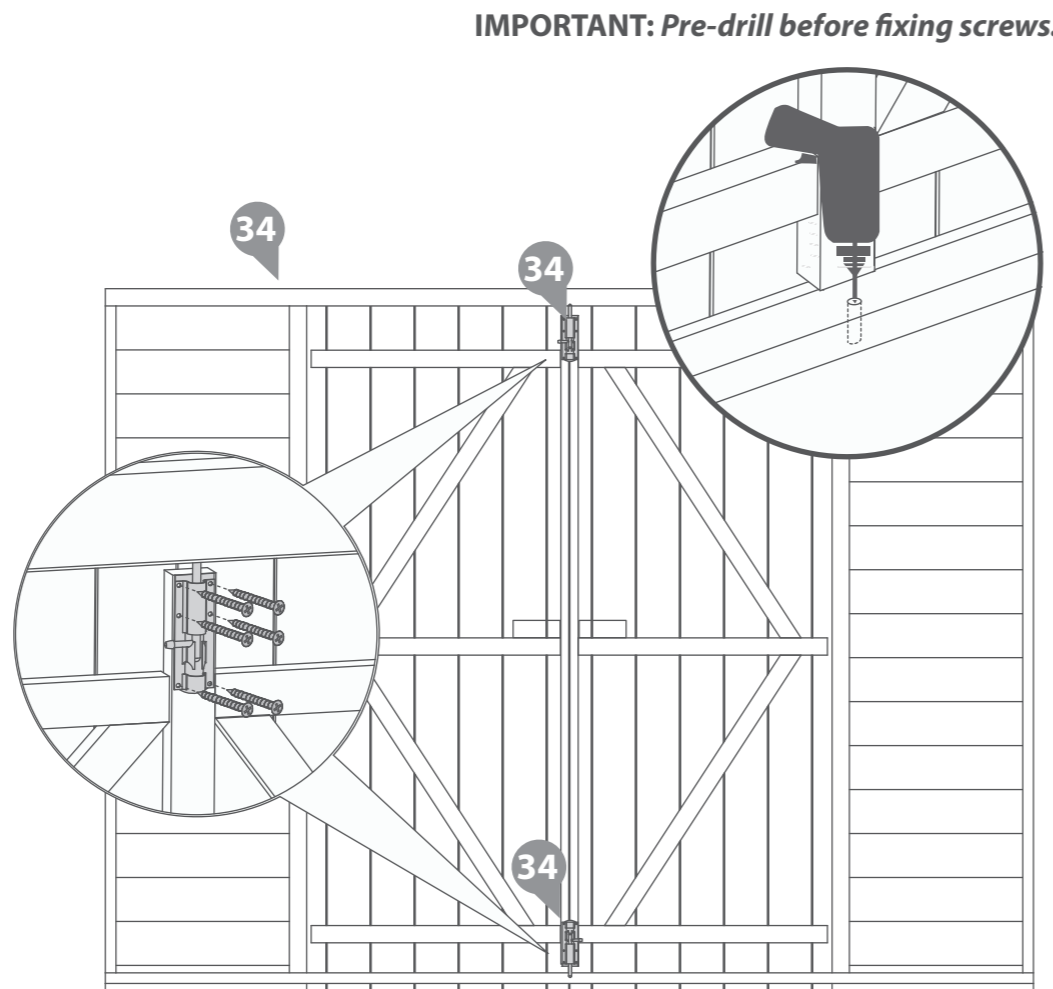
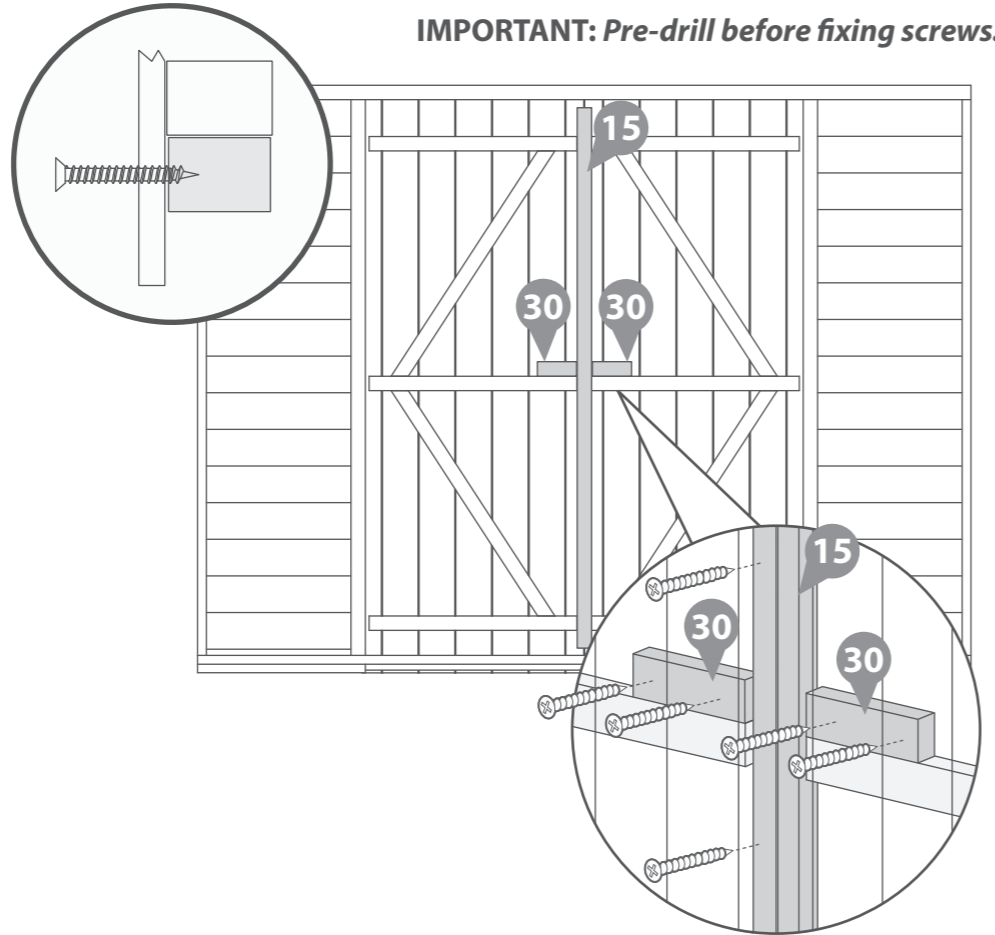
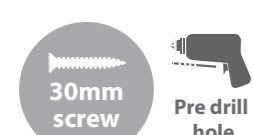

Step 28

Parts Needed- No.39 QTY 2

Align the lock (No.39) to the door, ensuring equal spacing across the doors and in line with the door framing.

Measure and mark the holes of the lock (No.39) and drill through the boards and through the framing and door blocks.

Fix the lock onto the door using 8x60mm Carriage Bolts and Nuts.

8x60mm Carriage Bolts

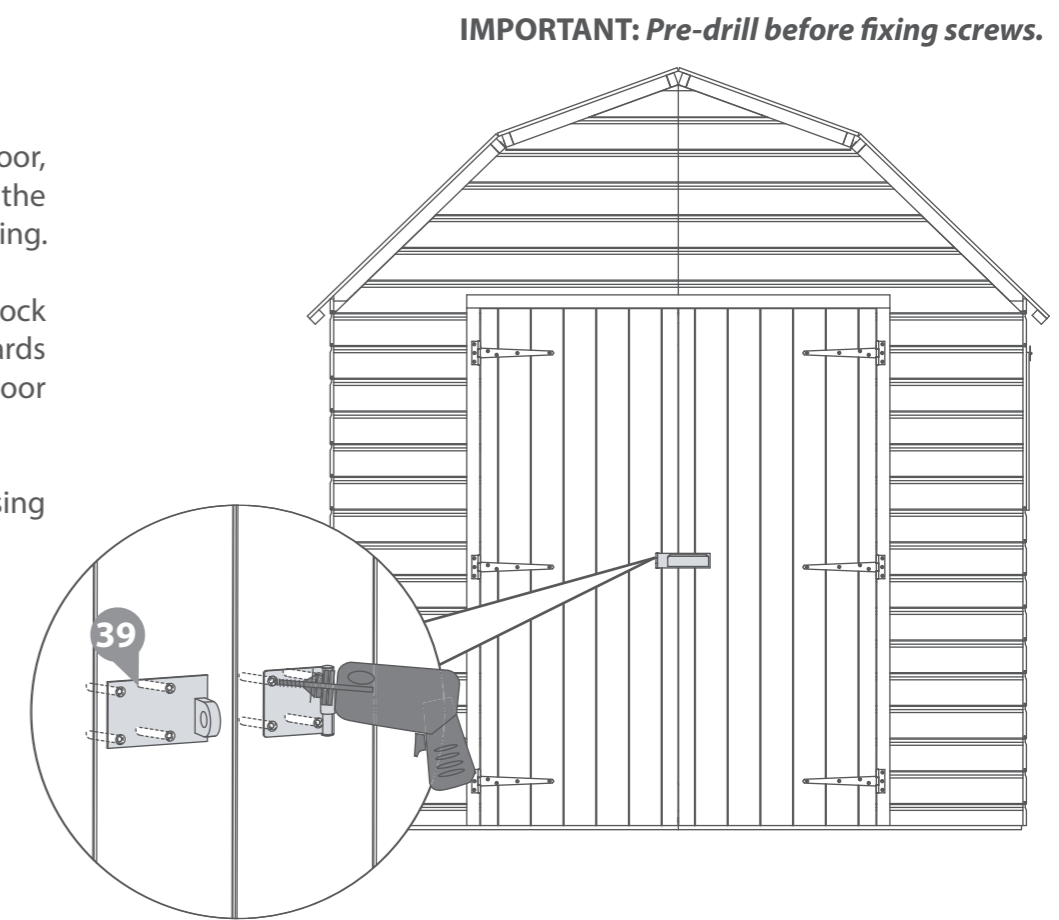
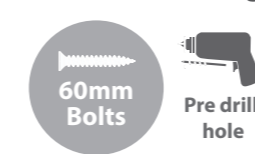

Step 29

Parts Needed- No.35 QTY 2

Attach the turn buttons (No.35) to the secondary door at the top and bottom using 1x30mm screw per turn button.

2x30mm Screws

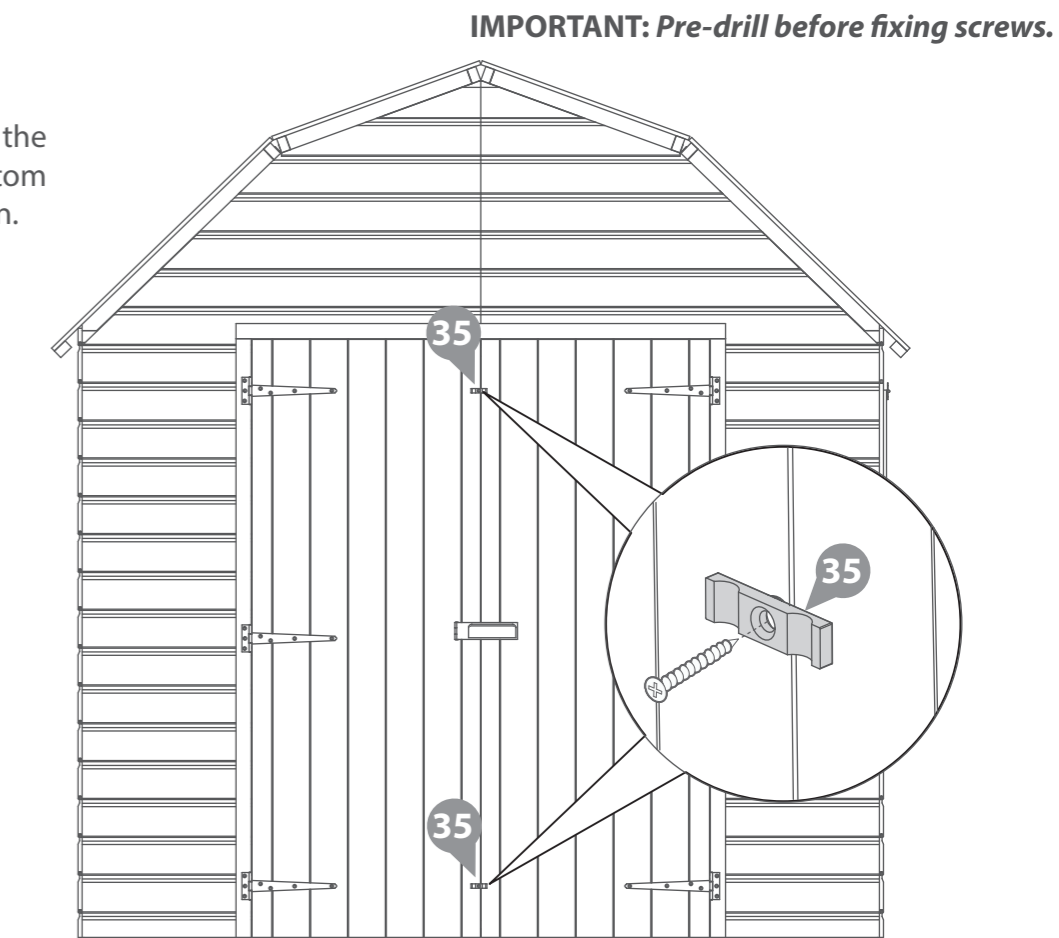
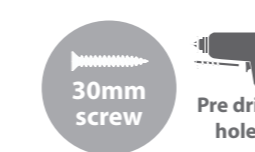

Step 30

Parts Needed- No.13 QTY 2
 - No.18 QTY 2
 - No.36 QTY 4

Place the Window Strip (No.18) 11mm above the window gap in the window panel and fix with 3x30mm screws per strip.

6x30mm Screws

Opening Window

If you would like the windows to be opening use the Butt Hinges (No.36) to attach to the window strip and the Window (No.13) together. Use 30mm screws to fix the butt hinge to the Window Strip and 16mm screws to fix it to the Window.

12x30mm Screws

12x16mm Screws

Fixed Window

If you want to fix the windows, instead of fixing butt hinges to the opening window, use 4x30mm screws to attach the window (No.13) to the window side panel as shown in the diagram.

8x30mm Screws

30mm screw

16mm screw

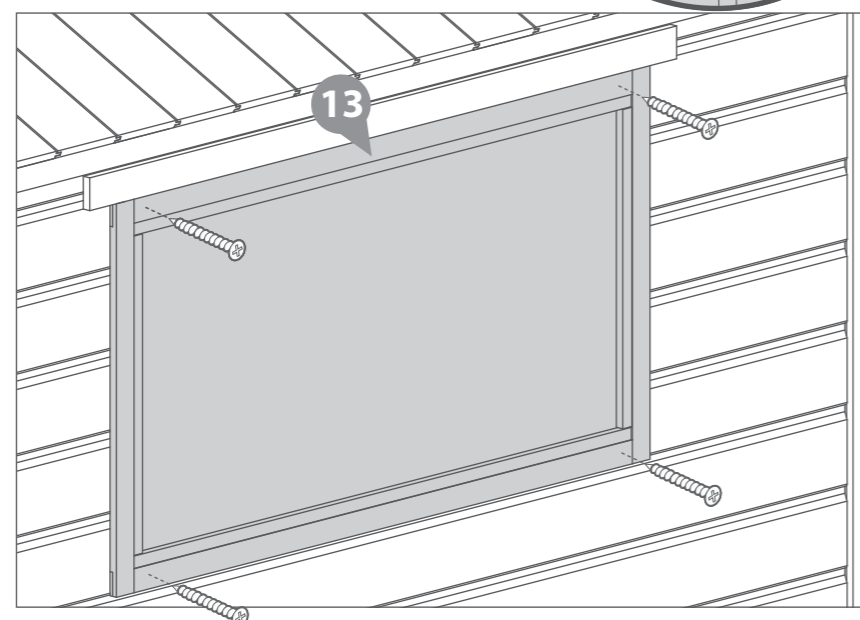
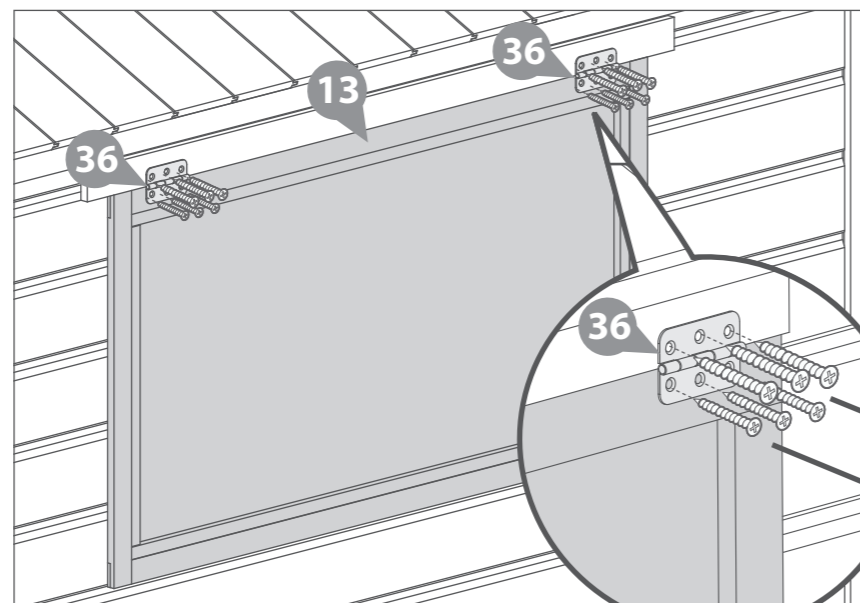
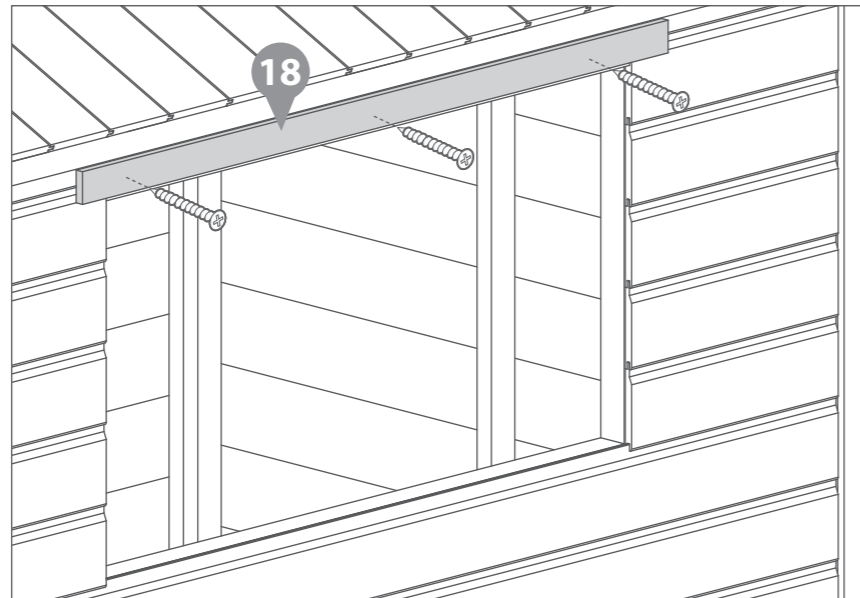

IMPORTANT: Pre-drill before fixing screws.

Step 31

Parts Needed- No.32 QTY 2

Fix the Casement Stay (No.32) to the opening window then align the fixings onto the window panel frame.

Ensure the casement stay fits into fixings when closed before screwing them down using 6x16mm screws per casement stay.

12x16mm Screws

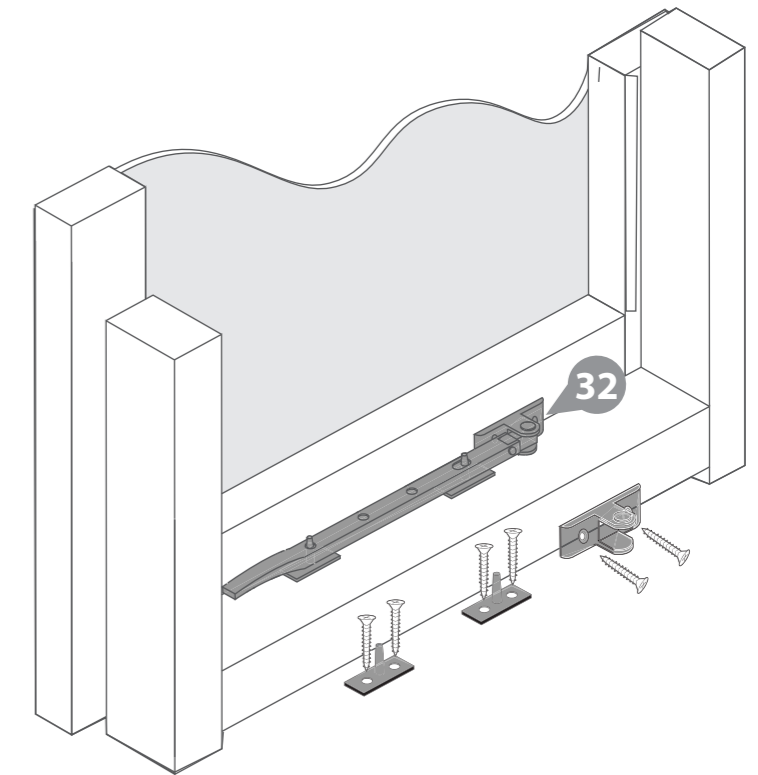
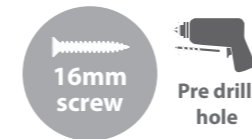

IMPORTANT: Pre-drill before fixing screws.

Step 32

Parts Needed- No.19 QTY 7
 - No.20 QTY 1

Fit the Cover Trims (No.19) to the building at each corner and panel join, secure in place with 3x30mm screws per cover trim.

Fix the gable cover trim (No.20) to the back of the building using 2x30mm screws, ensuring it sits flush with the fitted cover trim below.

23x30mm Screws

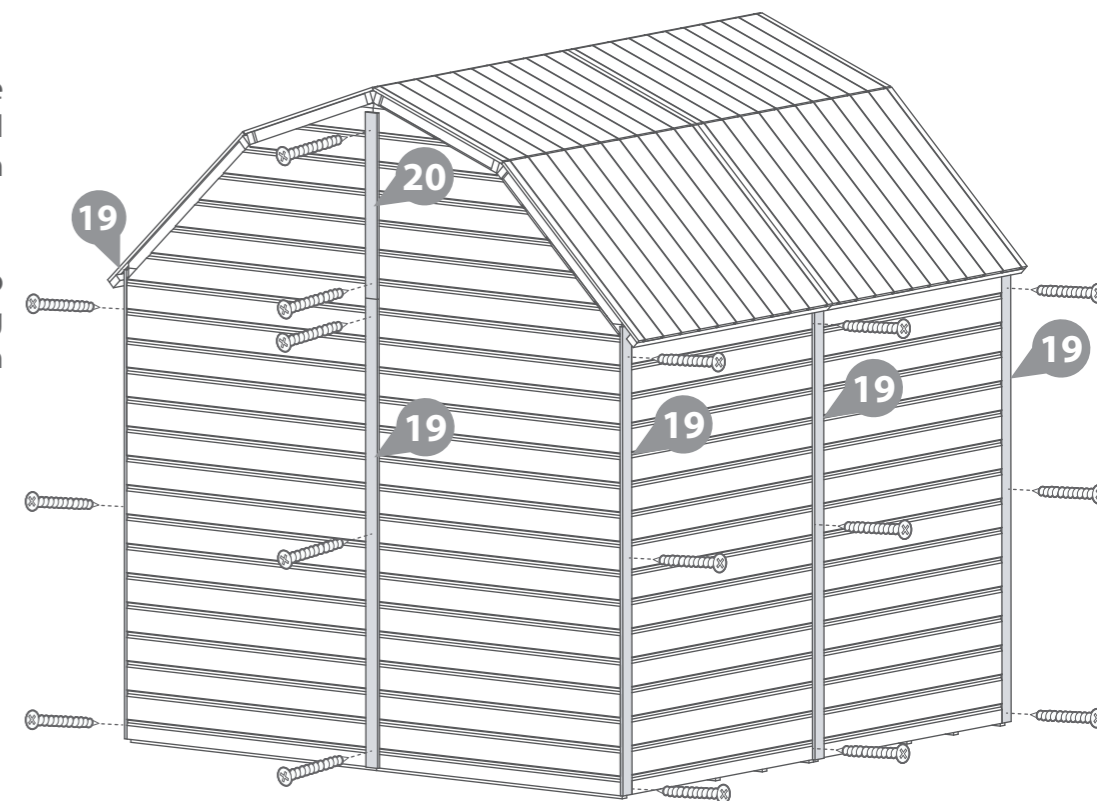
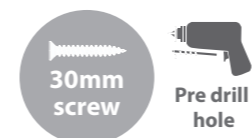

IMPORTANT: Pre-drill before fixing screws.

Step 33

Parts Needed- No.37 QTY 1

Cut four strips of felt (No.37) measuring 2500mm (L) x 1000mm (W) and place onto the roof.

Lay the felt onto the roof in the order stated in the diagram below. Ensure there is a 50mm overhang over each end and the layers overlap by 100mm.

Once the sheets are laid out, fix them onto the roof using felt tacks 100mm apart.

125 x Felt tack

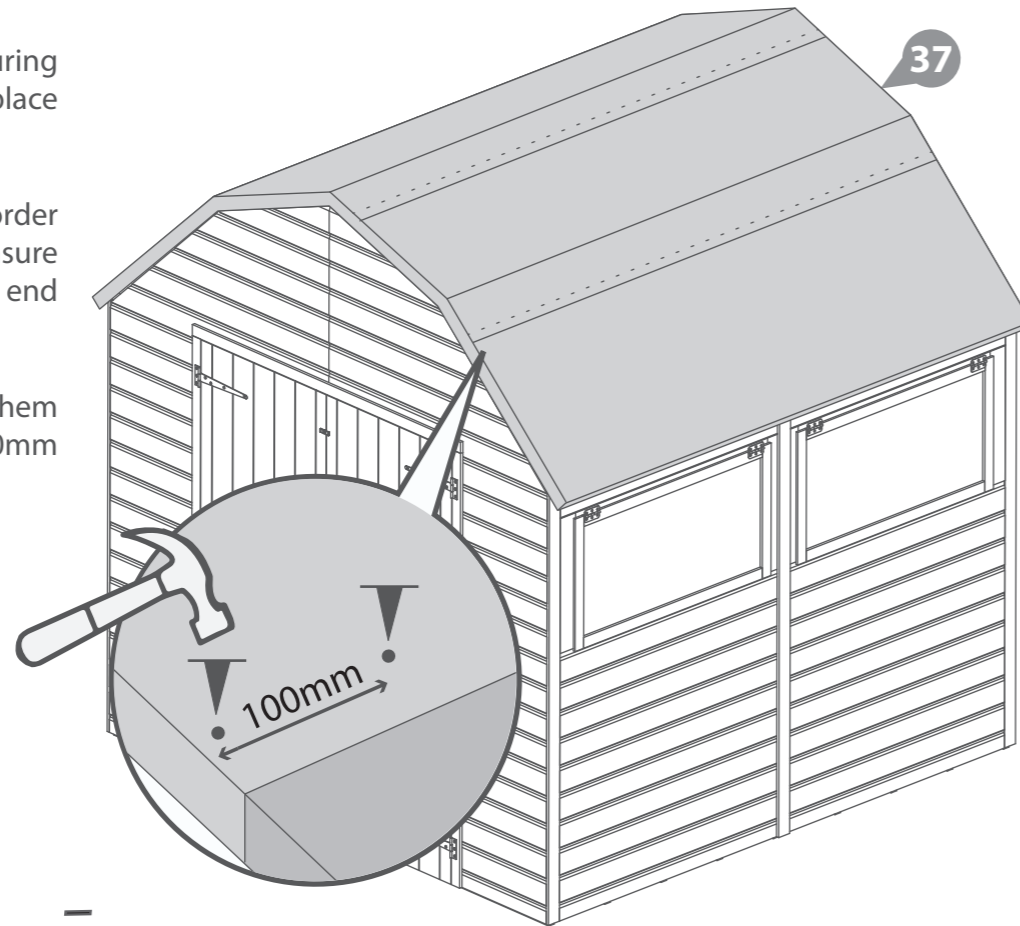

IMPORTANT: Pre-drill before fixing screws.

Step 34

Parts Needed- No.25 QTY 4
- No.27 QTY 4

Locate the Fascias (No.25 & 27) to the front and rear of the building, ensuring the angled edges align, are flush and level.

Fix in place using 3x30mm screws per fascia.

Ensure to screw through the boards into the framing.

24x30mm Screws

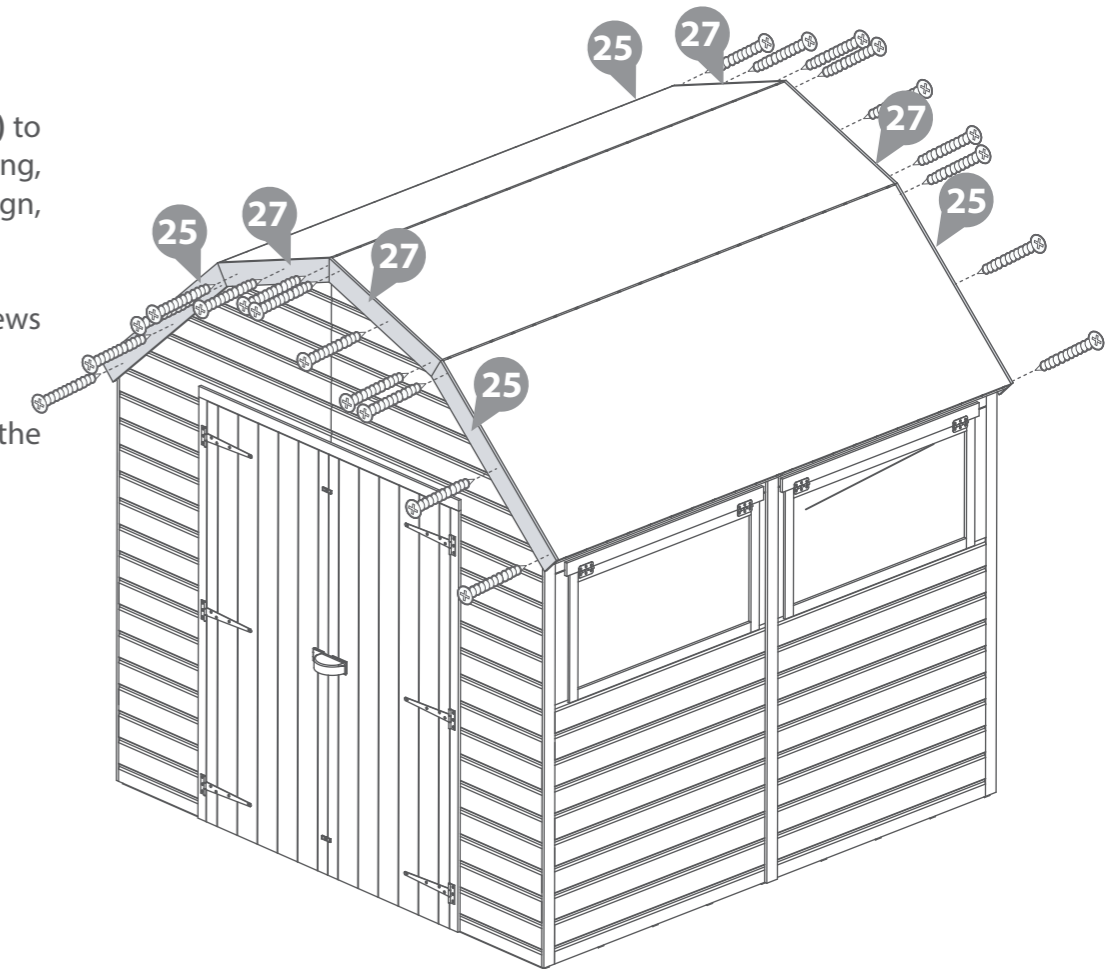
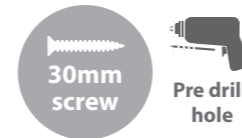

IMPORTANT: Pre-drill before fixing screws.

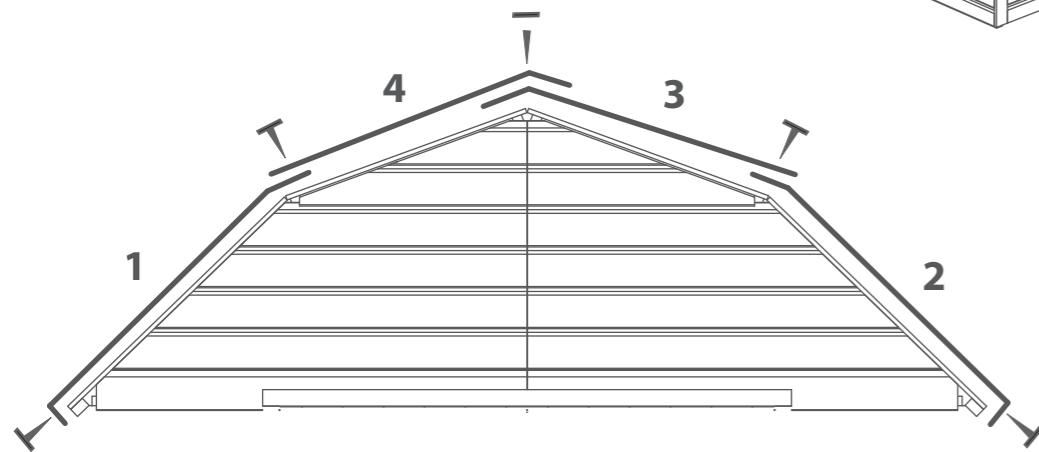

1

2

3

4

HANDLE WITH CARE

X

✓

Step 34

Parts Needed- No.24 QTY 1
- No.26 QTY 2

Locate the Barge Boards (No.24 & 26) to the front of the building, ensuring the angled edges align, are flush and level.

Secure in place using 3x30mm screws per Barge Board.

Ensure to screw through the boards into the Gable top cladding.

9x20mm Screws

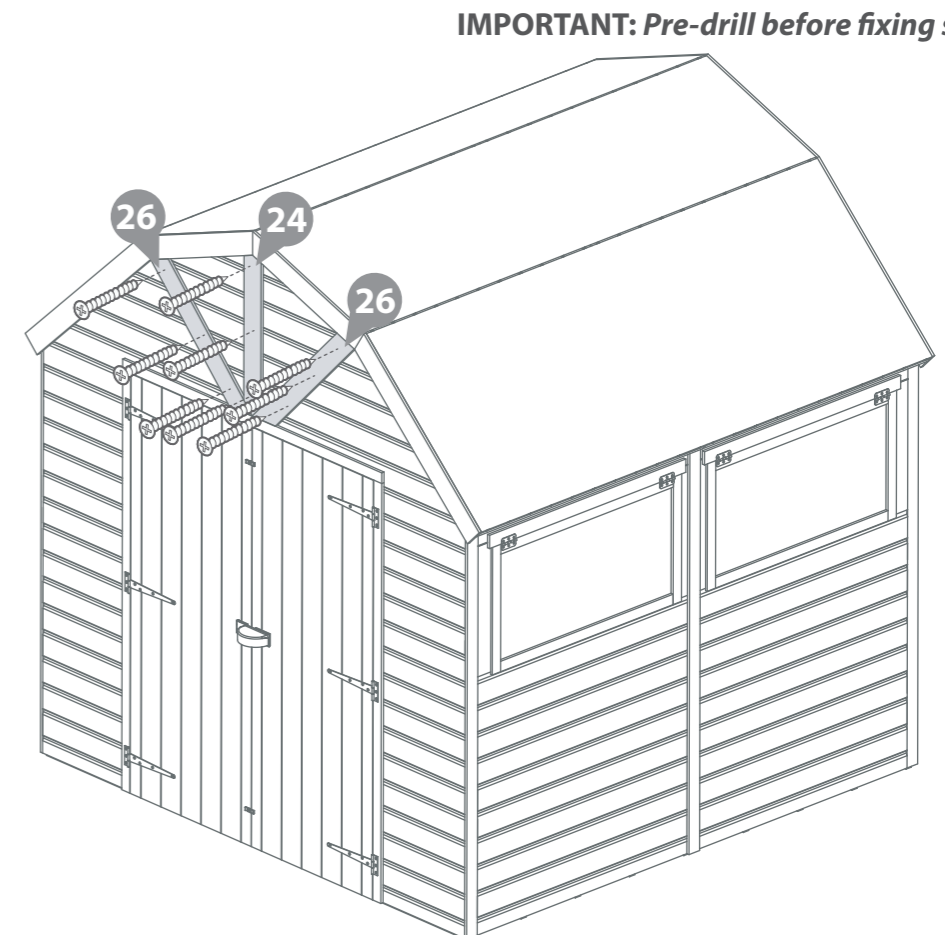
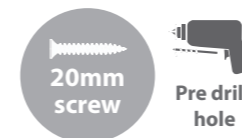

IMPORTANT: Pre-drill before fixing screws.

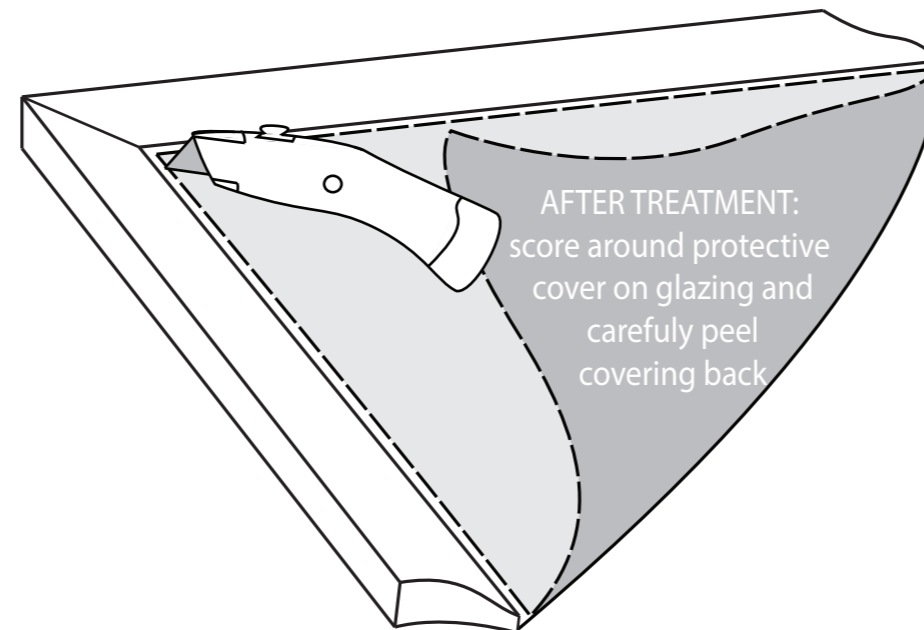

LEAVE US A REVIEW...

Want to share your experience with us?
Leave us a review on Feefo, TrustPilot or Google.

Your reviews help other people find and trust our business, as well as helping to play an important role in our growth and improvement!

TREATING YOUR GARDEN BUILDING

Preservation of wood that's outdoors is vital. A little early care will help protect your garden building, improve its appearance and ensure maximum longevity. Insects, moisture, salt, and changing weather can have dramatic effects on the stability and appearance of your garden building. Once your building is installed, you've checked it over and you're happy with it, you can take a few basic precautions to prepare it for the elements. Treating your garden building helps prevent decay and, by repelling water, discourages the growth of moulds and fungi that could jeopardise the structural integrity of the wood.

Dip Treated buildings - Require a preservative treatment to protect against rot and decay and a waterproof treatment to prevent water ingress
Pressure Treated buildings - Require a waterproof treatment to prevent water ingress
Log Cabins/Insulated Garden Rooms - Are supplied untreated and require a preservative and waterproofing treatment.



ANY QUESTIONS?
Scan the QR code to contact us via our customer portal.

To apply a preservative and water proofing treatment (pressure treated products do not require a preserver), follow the manufacturer's instructions but in principle, stick to the following steps:

- ✓ Wear latex or rubber gloves, eye protection and (if spraying) a mask.
- ✓ Prepare the wood, by sanding down any ridges or inconsistencies in the wood, smoothing out knots and end-cuts.
- ✓ Choose a dry day to treat your garden building. If you're spraying rather than brushing paint on, avoid a windy day.
- ✓ Be sure you can safely reach all the sections you need to paint - and if you need a ladder, make sure it's safely positioned before climbing. Lay dust sheets around to avoid paint splatters on your base or surrounding plants.

- ✓ Tape around windowpanes to avoid smears when you're painting the frames.
- ✓ Keep pets and small children out of the way. The last thing you want is to have fur on your garden building paint, or little painted footprints all over your garden and home.
- ✓ Fill any gaps in the building's body with caulk or wood filler to prevent water and draughts getting in. Silicone based caulk is flexible and will move with the timber when temperature and humidity change. Allow to dry completely before treating. A handy tip for finding gaps is to go into your garden building and look for light leaking through joins and frames. If light gets in, then so will water.
- ✓ Liberally apply at least two coats of the treatment products with a brush or spray, taking care to allow the first coat to completely dry before applying the second.
- ✓ Make sure the solution permeates the whole of the surface area, especially around natural cracks, end cuts and nail/screw holes.



APPLY WOOD TREATMENT
IMMEDIATELY
AFTER ASSEMBLY

PLEASE SCAN HERE TO
SEE TREATMENT VIDEO:



1 Perimeter

Check around the perimeter of your product to ensure there are not trees or plants that are in contact with or overhanging the building. This can affect airflow and overhanging trees, or branches can damage the roof, it is advised to keep plants at a distance.

2 Repair

Inspect the interior and exterior of the product to look for splits, cracks, and holes. Although this is a natural occurrence it can be prevented. A wood filler can be used to close the splits, cracks, and holes.

3 Roof

Check your roof regularly for tears, splits, damaged wood and fallen debris. If you notice any of this immediate repair is critical.

4 Doors & Windows

Expansion and contraction can cause doors and windows to stick or become difficult to open. Small adjustments to the hinge position can be made to the doors and windows to allow free movement.

5 Oil

Hinges can seize up over time, apply lubricant to the hinges and locks annually.

6 Screws & Bolts

It is advised to check all screws and bolts and tighten any loose you might find. For log cabins specifically the storm braces will require loosening. During humidity and temperature changes (seasons) to allow expansion and contraction to prevent gaping, twisting, popping, and warping.

7 Wash

At least once a year, give the outside of you building a good wash, to remove cobwebs, leaves, or any other dirt that may accumulate on the exterior.

8 Airing

Airing your product regularly prevents the build up of condensation which can cause the timber to rot and mould. Condensation can build up over time or daily, it is caused by a rise and fall in temperature. Leaving doors and windows open regularly can help combat the natural moisture build up.

9 Clean & Tidy

It is good practice to clean the inside and outside of your product regularly. Clear out the contents, sweep the floor, remove dirt and cobwebs. Check for areas of damp and investigate the cause to remove and prevent future occurrences. Check the ground around your product for build up of debris such as leaves, remove and ensure there is clear ventilation underneath the floor.

Additional Playhouse Maintenance:

It is recommended that the following checks and maintenance are carried out at the beginning of each season as well as at regular intervals during the usage season.

- Check all nuts /bolts/ screws for tightness and tighten when required.
- Check for movement / opening of wood giving rise to protrusion of nail heads and tips.
- Check hinges.
- Replace defective parts in accordance with the manufacturers instructions.
- Check any crossbeams, suspensions and anchors.
- If a swing is included; check the swing seat, chains and ropes.

IF THESE CHECKS ARE NOT CARRIED OUT THE ACTIVITY TOY COULD BECOME A HAZARD

All our garden buildings have been designed and manufactured with care and attention to be the perfect addition to your outdoor space. To ensure you do get the best out of your new garden building and to increase the longevity we advise that you follow the product instructions and our manufacturer's recommendations as detailed below. Thank you for choosing a Mercia Garden product!

1 Choosing the most suitable location for your garden building...

A minimum of 60cm should be left around the perimeter of your garden building to allow access for maintenance, annual treatment and to allow air flow around the building.

Where possible you should avoid placing your garden building underneath large trees to prevent the tree causing damage to the building.

2 Preparing the base for your garden building...

All our buildings must be built on a firm, level base to ensure the longevity of the building and prevent the wood from distorting. We recommend either concrete, concrete slabs or a wooden base, such as our 'Portabase'.

The base should be slightly smaller than the external measurement of the building, i.e. the cladding should overlap the base, creating a run off for water and preventing water from pooling underneath the building.

We also recommend that the floor of the garden building is a minimum of 25mm above the surrounding ground level to avoid flooding.

3 After installation...

Once your garden building has been installed, it will need to be treated within 14 days (weather permitting) and annually to prevent the timber from deteriorating and to waterproof it. This is required to maintain the anti-rot guarantee.

Dip Treated buildings - Require a preservative treatment to protect against rot and decay

and a waterproof treatment to prevent water ingress.

Pressure Treated buildings - Require a waterproof treatment to prevent water ingress.

Log Cabins/Insulated Garden Rooms - Are supplied untreated and require a preservative and waterproofing treatment.

We also recommend using a silicon sealant on the inside and outside of the windows as soon as possible after assembly and treatment to fully seal the windows.

Roofing felt/covering should be checked annually and replaced or fixed accordingly.

4 General maintenance and wood characteristics

As wood is a natural material it may be affected by the following:

Shrinkage and warping - The timber used in the construction of your garden building will have retained some of its natural moisture content. The moisture content of the timber will vary, depending upon prevailing environmental conditions, which will result in the components either naturally expanding or contracting. As the components dry out, shrinkage may occur. A good waterproofing treatment from the start is the best protection to minimise the effect of moisture loss/intake.

In extended periods of very warm weather getting some moisture to the building will help the overall balance. You can do this by spraying it down lightly with a garden hose. In contrast, after snow fall try to remove the snow as best as possible from the roof to prevent moisture intake and to remove the extra weight.

Top tip - using a garden brush will help you to reach the highest part of the building to remove snow and any debris left from bad weather.

Damp and mould - During the winter months, cold and damp conditions can result in an increased amount of moisture within your garden building, especially when used infrequently. Condensation can form on the timber and other items stored within your garden building. If left this moisture is likely to cause mould and mildew.

To prevent the build-up of moisture, we recommend leaving the door or windows of your building open from time to time, to allow the fresh air to circulate. We also advise against storing wet or damp items in your garden building as this will also increase the level of moisture in the building. If mould or mildew does start to form within your building we recommend using an anti-mould cleaner to remove it and to prevent it spreading, which if left untreated could permanently damage your garden building.

Splits, cracks and knots - You may notice small splits and cracks in some components or holes may appear where knots shrink and fall out. This will not affect the structure of your Garden building however, if you wish to fill them this can be easily done using any good quality wood filler.

Sap - is naturally occurring in wood and may appear in some boards of your garden building. If you wish to remove the sap, we advise waiting until it is dry and then using a sharp knife to carefully remove it. If the removal of the sap causes a hole in the timber, we recommend using a good quality wood filler to fill it.

For more handy hints and tips on how to care and maintain your garden building please refer to the MGP Customer Portal at www.mgplogistics.co.uk

Any further questions?

Contact our
Customer Service Team via the MGP
Customer Portal at:
www.mgplogistics.co.uk

1

Manufacturer's Warranty

All Mercia Garden Products are supplied with a 1 year warranty on all parts against manufacturing defects.

This warranty does not cover movement, warping or splitting of timber products over time.

This warranty will be voided if any of the following occur:

1. The building has been customised or modified/adapted in any way.
2. The person claiming is not the original purchaser of the building.
3. Any damage has been caused by or as a result of misuse.
4. The building has not been maintained and cared for in accordance to our advisories and manufacturer's recommendations.
5. The building has not been treated annually or as per the manufacturer's recommendations, please ensure receipts are kept to validate this claim.
6. The building has not been erected, fitted or installed as per the supplier instructions.
7. The building has not been erected on a suitable sized firm flat, solid level concrete/slab base or placed on pressure treated bearers.
8. The building is or has been placed with 2 feet (600mm) of any obstructions (walls, trees, plants, fences etc.) which can allow moisture to penetrate the timber.
9. The roofing felt has been incorrectly fitted or damaged, allowing water ingress, or has not been properly maintained.
10. Any windows and joints have not been sealed, inside and out, with silicone or other watertight sealant.
11. Any timber has been cut, pierced or drilled without subsequent application of approved cut-end treatment.

2

Anti-rot Guarantee

Mercia Garden Products offer a 10 year anti-rot guarantee on all dip treated (a preparatory treatment) and 15 years on all pressure treated products. This guarantee covers solid timber against rot, decay, blue stain and insect attacks.

To validate the guarantee, the building must be treated (as detailed within manufacturer's recommendations) within 14 days (weather permitting) of assembly and annually thereafter.

This guarantee does not cover movement, warping or splitting of timber products over time.

This guarantee will be voided if any of the following occur:

1. The building has been customised or modified/adapted in any way.
2. The person claiming is not the original purchaser of the building.
3. Any damage is caused by or as a result of misuse.
4. The building has not been maintained and cared for in accordance to our advisories and manufacturer's recommendations.
5. The building has not been treated annually or as per the manufacturer's recommendations, please ensure receipts are kept to validate this claim.
6. The building has not been erected, fitted or installed as per the supplier instructions.
7. The building has not been erected on a suitable sized firm flat, solid level concrete/slab base or placed on pressure treated bearers.
8. The building is or has been placed with 600mm of any obstructions (walls, trees, plants, fences etc.) which can allow moisture to penetrate the timber.
9. The roofing felt has been incorrectly fitted or damaged allowing water ingress, or has not been properly maintained.
10. Any windows and joints have not been sealed, inside and out, with silicone or other watertight sealant.
11. Any timber has been cut, pierced or drilled without subsequent application of approved cut-end treatment.



REGISTER FOR YOUR
ANTI-ROT
GUARANTEE TODAY

PLEASE SCAN HERE:

