

01D TOVAX0604SDFW-V2 & 01D TOVAX0604SDNW-V2

6X4 APEX OVERLAP SHED.

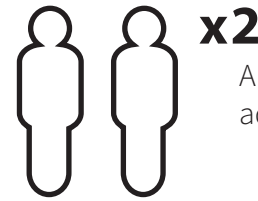

x2

All buildings should be erected by two adults

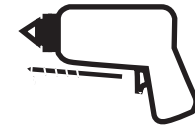

2mm Drill bit

For ease of assembly, you **MUST** pilot drill all screw holes and ensure all screw heads are countersunk.



For ease of assembly, you will need a tape measure to check dimensions of components and fixings.



Winter = High Moisture = Expansion  
Summer = Low Moisture = Contraction



**CAUTION**

Every effort has been made during the manufacturing process to eliminate the prospect of splinters on rough surfaces of the timber. You are strongly advised to wear gloves when working with or handling rough sawn timber.

**\*\*Protim Aquatan T5 (621)\*\***

Your building has been dip treated with Aquatan.

Aquatan is a water-based concentrate which is diluted with water, the building has been treated by the correct application of Aquatan solution and then allowed to dry.

Aquatan is a decorative finish to colour the wood, which is applied industrially to timber fence panels and garden buildings.

Aquatan undiluted contains: boric acid, sodium hydroxide 32% solution, aqueous mixture of sodium dioctyl sulphosuccinat and alcohols: 2, 4, 6-trichlorophenol.

REGISTER FOR YOUR  
**10 YEAR**  
**ANTI-ROT**  
GUARANTEE TODAY

In all instances for assistance with your product or to register your anti rot guarantee, please contact us via our customer portal



[www.mgplogistics.co.uk](http://www.mgplogistics.co.uk)

Mercia Garden Products Limited, Sutton On Trent, Newark, Nottinghamshire, NG23 6QN

**Screws & Nails**

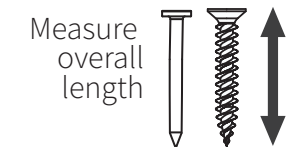

**Bolts**

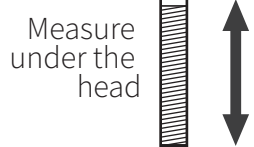

**BEFORE YOU START PLEASE READ THE INSTRUCTIONS CAREFULLY**

- Check the pack and make sure you have all the items listed in the parts list provided.
- When you are ready to start, make sure you have the right tools at hand (not supplied - see the equipment list on next page).
- Ensure there is plenty of space and a clean dry area for assembly.
- Ensure you have enough time to build the product to ensure the building is water tight.

**LOCATION FOR YOUR GARDEN BUILDING**

A minimum of 600mm should be left around the perimeter of your garden building to allow access for maintenance, annual treatment and to allow air flow around the building.

Where possible you should avoid placing your garden building underneath large trees to prevent the tree causing damage to the building.

**BUILDING A BASE**

When thinking about where the building and where the base is going to be constructed: Ensure that there will be access to all sides for maintenance work and annual treatment.

Ensure the base is level and is built on firm ground, to prevent movement. Refer to the contents page for the base dimensions. The base should be slightly smaller than the external measurement of the building, i.e. The cladding should overlap the base, creating a run off for water. It is also recommended that the floor be at least 25mm above the surrounding ground level to avoid flooding.

**TYPES OF BASE**

- Concrete 75mm laid on top of 75mm hard-core.
- Slabs laid on 50mm of sharp sand.
- Wooden base - Levelled / on posts / ground screws.

**TREATMENT**

Once your garden building has been installed it will need to be treated within 14 days (weather permitting) and annually to prevent the timber from deteriorating and to waterproof it. This is required to maintain the anti-rot guarantee.

Dip Treated buildings - Require a preservative treatment to protect against rot and decay and a waterproof treatment to prevent water ingress

Pressure Treated buildings - Require a waterproof treatment to prevent water ingress

Log Cabins/Insulated Garden Rooms - Are supplied untreated and require a preservative and waterproofing treatment.

**TIMBER**

As with all natural materials, timber can be affected during various weather conditions. For the duration of heavy or extended periods of rain, swelling of the wood panels may occur. Warping of the wood may also occur during excessive dry spells due to an interior moisture loss. Unfortunately, these processes cannot be avoided but can be helped. It is suggested that the outdoor building is sprayed with water during extended periods of warm sunshine and sheltered as much as possible during rain or snow.

## TO DO LIST

- Find a suitable location to build (*see front cover for further information*).
- Build a base (*see front cover for further information*).
- Check the base is flat, level, clear of debris and has 60cm clearance on all sides.
- Check you have the required equipment / tools.
- Check you have all the product items listed (*if you have missing or damaged parts please scan the QR code below to visit our online customer portal*).
- Install the product as per the step by step instructions within this pack.
- Prepare the product ready for treatment (this may include sanding).
- Apply a preserving and a waterproofing treatment within 14 days (*weather permitting*) of installation (*pressure treated products do not require a preserver*).
- Register for your anti rot guarantee (*scan the QR below*).
- Tidy the build area and dispose of any remaining parts responsibly.
- Maintain your building (*see the manufacturers recommendations at the back of this pack*).

## EQUIPMENT LIST

- Hammer
- Flat Head Screwdriver
- Drill
- Drill Bit Set
- Phillips and Slotted Bit Sets
- Tape Measure
- Hand Saw
- Spirit Level
- Ladders/Steps
- Stanley Knife/Cutting Tool
- Sand Paper
- Gloves
- Silicone (For Windows Only)
- Sealant Application Gun
- Wood Filler (Optional)
- Timber Preservative Treatment (*not pressure treated products*)
- Timber Water Proofing Treatment
- Treatment Mixing Stick
- Paint Brush/Sprayer/Roller

## NEED EXTRA SUPPORT

If you are unsure that your base preparation will be suitable, please contact us via our customer portal to discuss this further.

Alternatively, you can visit our website or MGP Logistics Online Portal for some further shededucation.

**Website:**

<https://www.merciagardenproducts.co.uk/sheducation>

**MGP Logistics Online Portal:**

<https://www.mgplogistics.co.uk/>

Here you will find plenty of useful information that'll help with most pre-installation and maintenance queries.

**ANY QUESTIONS?**

Scan the QR code to contact us via our customer portal.

## NOTES

## ACCESSING VIDEO GUIDES...

Some steps within this set of instructions come with an added video guide for your convenience. These can be accessed via the QR code and used to aid you in constructing that step. See below for how to use.

You can also find all the videos on our youtube channel:  
<https://www.youtube.com/@merciagardenproducts8716/videos>

### 1. Find the QR code within the instruction step...

#### Step.....

Parts Needed- No. QTY 1  
No. QTY 1  
No. QTY 1

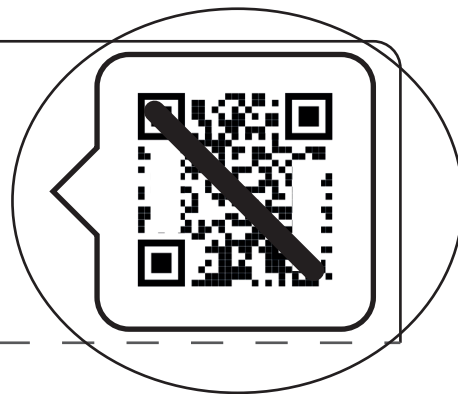

Within the instruction step, there will be an icon in the top right that has a QR code in. This is where the video can be accessed from.

*Please note: not every step has a video guide.*

### 2. Open camera app...

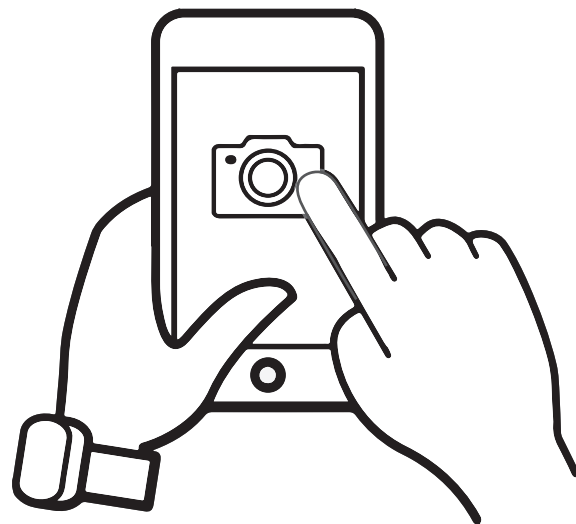

On your personal smart device (phone, tablet etc), open your camera app or QR code scanner app.

## ACCESSING VIDEO GUIDES...

### 3. Scan QR code...



To scan the QR code, hold the camera over the QR code so that it can be seen on the screen. Once the QR code has been registered, follow the prompts on your device to open the video. (This will vary depending on your device.)

*Please note: Ensure to use the back camera of your smart device as this will scan the QR code more accurately.*

### 4. Watch the video...

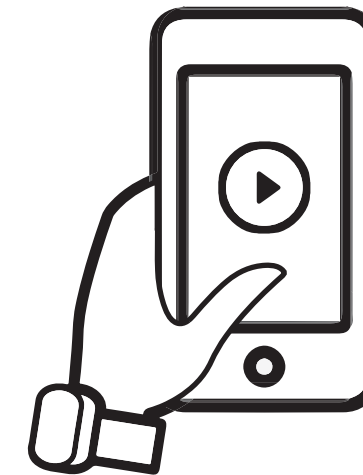

The video guide will now be displayed on your smart device.

**Disclaimer:** The garden building constructed in the video guides may be constructed differently to your building. Please ensure to read your instructions carefully to avoid error.

## 01DTONVAX0604SDFW-V2 & 01DTONVAX0604SDNW-V2

**Overall Dimensions:**  
 Width = 1318mm  
 Depth = 1842mm  
 Height = 1855mm

**Base Dimensions:**  
 Width = 1175mm  
 Depth = 1753mm

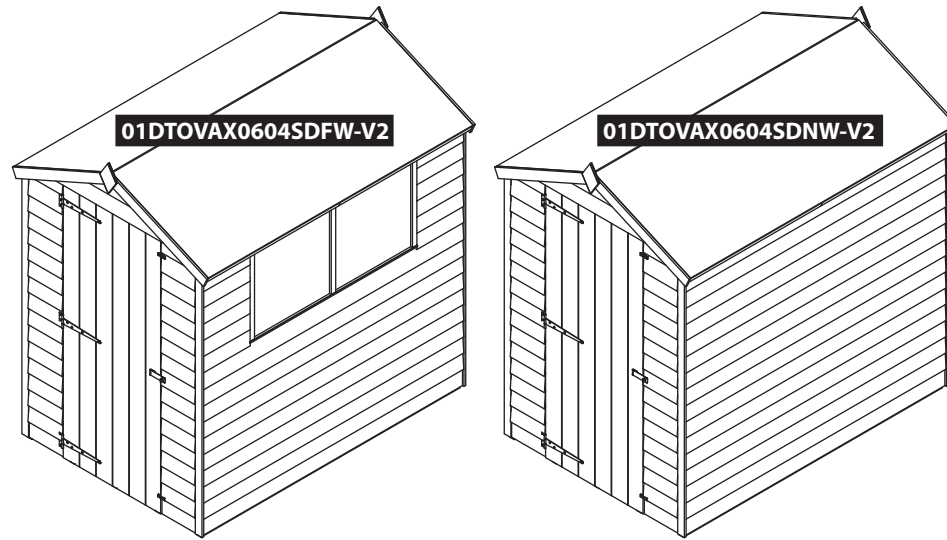

### Building Content:

Tip: Labelling your parts, using a pencil and masking tape, may help you to identify them easier when you need them.



1

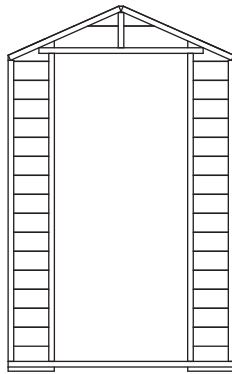

**Door Gable QTY 1**  
 AI-01R11OVAGSD1130X1826-V1

2

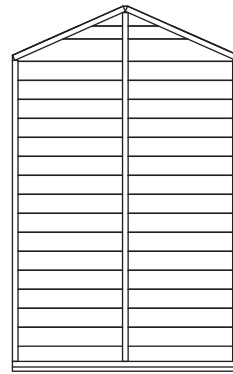

**Back Gable QTY 1**  
 AI-01R11OVAGP1130X1826-V1

3

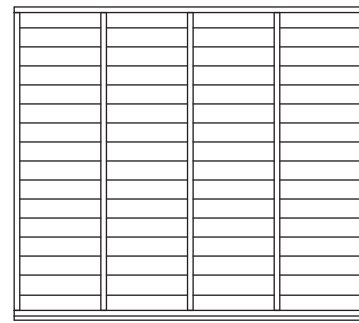

**Plain Panel QTY 1**  
 (QTY 2 WINDOWLESS ONLY)  
 AI-R11OVPP1763X1567-V1

4

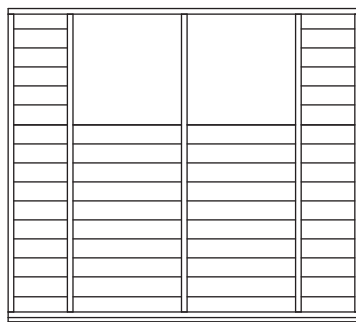

**Window Panel QTY 1**  
 (WITH WINDOW ONLY)  
 AI-01R11OV2CW1763X1567-V1

5

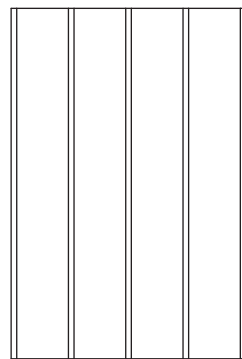

**Floor QTY 1**  
 AI-R11OSBF1175X1753-V1

6

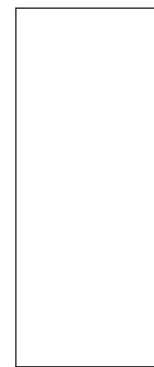

**Roof QTY 2**  
 PI-03-0222

7

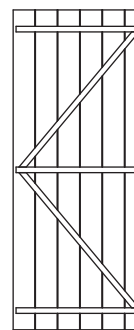

**Door QTY 1**  
 AI-R11FBMBZBD660X1600-V1

8



**Fascia 12x60x694mm QTY 4**  
 S1260-694mm

9

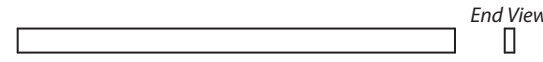

**Fixed Window Strip 12x30x546mm QTY 5 (WITH WINDOW ONLY)**  
 S1230-546mm

10

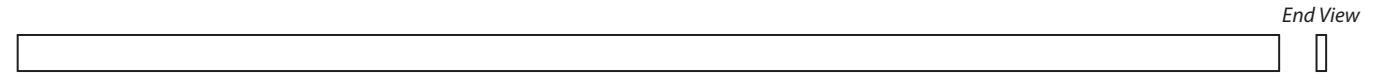

**Cover Trims 12x45x1575mm QTY 4**  
 S1245-1575mm

11

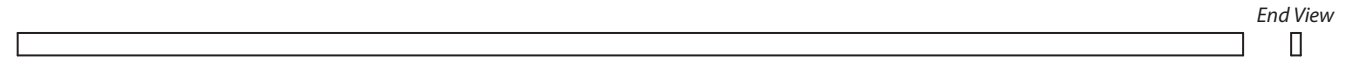

**Door Beading Strip 12x28x1530mm QTY 2**  
 S1228-1530mm

12

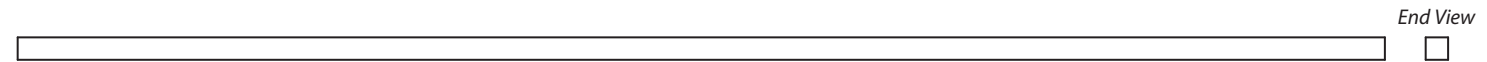

**Ridge Bar 28x28x1707mm QTY 1**  
 F2828-1707mm

13

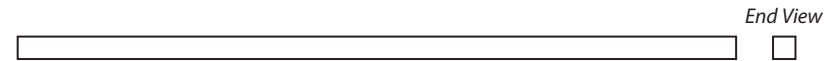

**Eaves Frame 28x28x897mm QTY 4**  
 F2828-897mm

14



**Finial QTY 2**  
 SHED DIAMOND FINIAL

17



**Turn Button QTY 2**  
 PI-07-0034

20

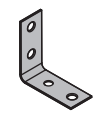

**L-Bracket QTY 2**  
 PI-07-0012

15

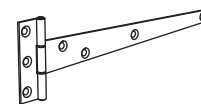

**T-Hinge QTY 3**  
 PI-02-1042

18

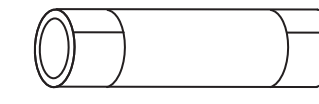

**Felt**

21



**Hasp and Staple QTY 1**  
 PI-07-0207

16



**Plastic Window Cill**  
 (WITH WINDOW ONLY)  
 PI-08-0013

19



**Styrene QTY 2**  
 (WITH WINDOW ONLY)  
 PI-05-0114

### Screw Pack:

There may be extra screws in the pack.



**50mm Screw x 30**



**30mm Screw x 98**

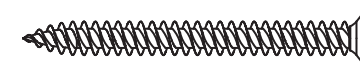

**40mm Screw x 34**



**Felt Tacks x 60**

### Pre Assembly

Before assembling remove the transportation blocks from the bottom of each panel.

Take care removing the blocks as to not damage the panels. Tap with a flat headed screwdriver and hammer.

Dispose of the blocks once removed.

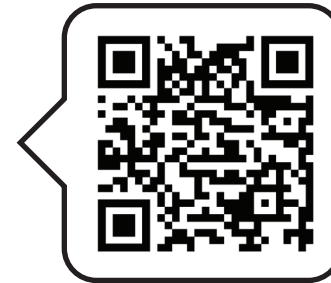

**Before assembly, please make sure you have a suitable base ready to install your building onto.**

### Step 1

Parts needed - No. 5 QTY 1

Place the floor (**No. 5**) on a firm and level base, ensure the base has suitable drainage free from areas where standing water can collect. See the front page for base requirements.

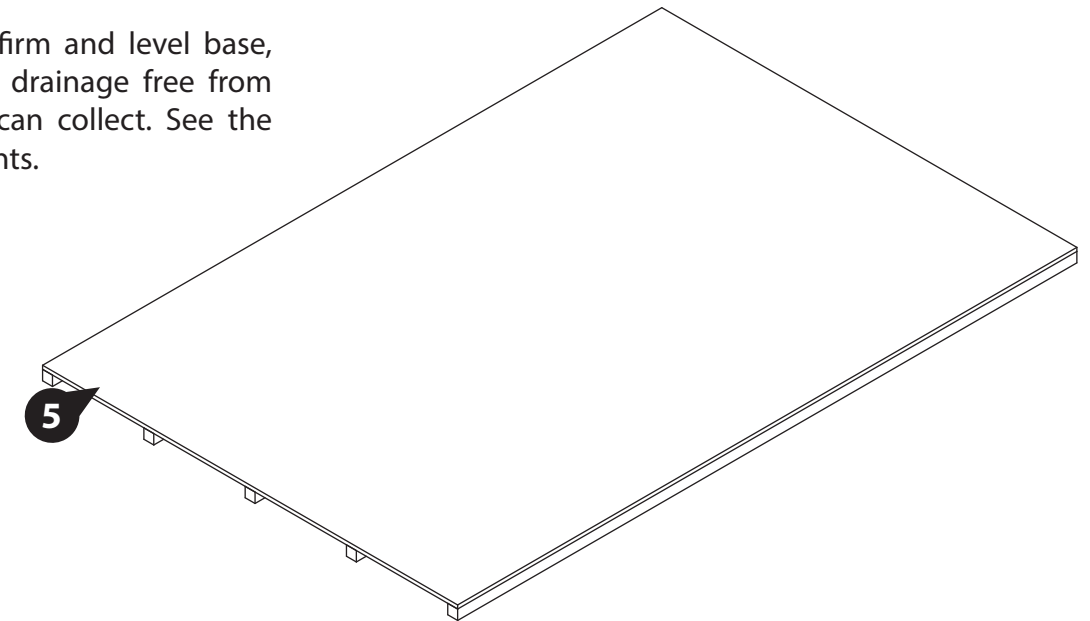
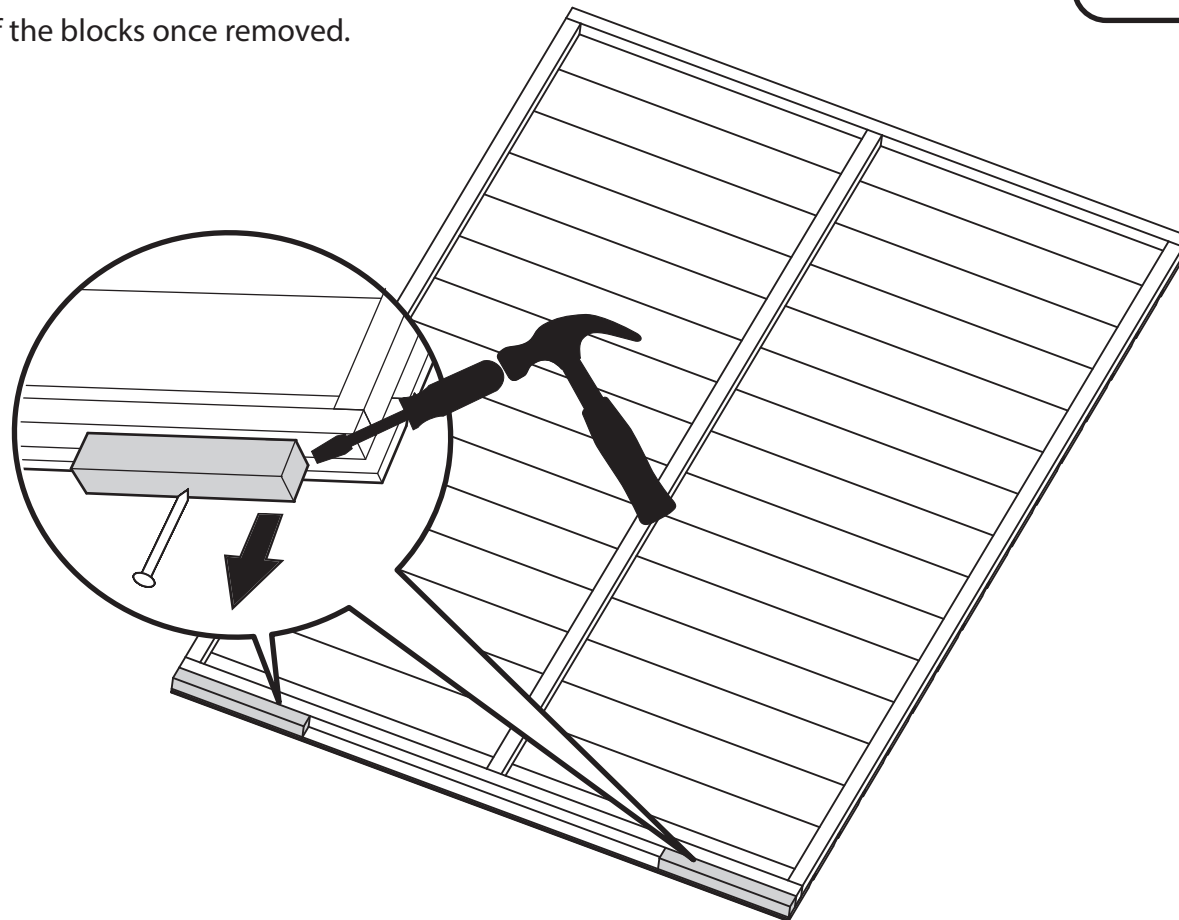

### Missing parts?

Scan the QR code to visit our customer portal where you can quickly raise any missing or damaged parts and get a replacement sent out ASAP.





# Step 2

Parts needed - No. 1 QTY 1  
No. 7 QTY 1  
No. 15 QTY 3

Place the door (No. 7) within the door aperture in the Door Gable (No. 1). Fix the T Hinges (No. 15) onto the door and Door Gable using 7x30mm screws per hinge (taking into account on which side of the Door Gable opening you want the Door to open).

Ensure that the screws go through the cladding and into the framing behind.

### 21x30mm screws



**\*\*PLEASE NOTE\*\*** Before fitting the hinges, ensure the door is in the correct position depending on which side you want the door to open. See external illustrations below which show the doors internal framing.

**IMPORTANT: Pre-drill before fixing screws.**

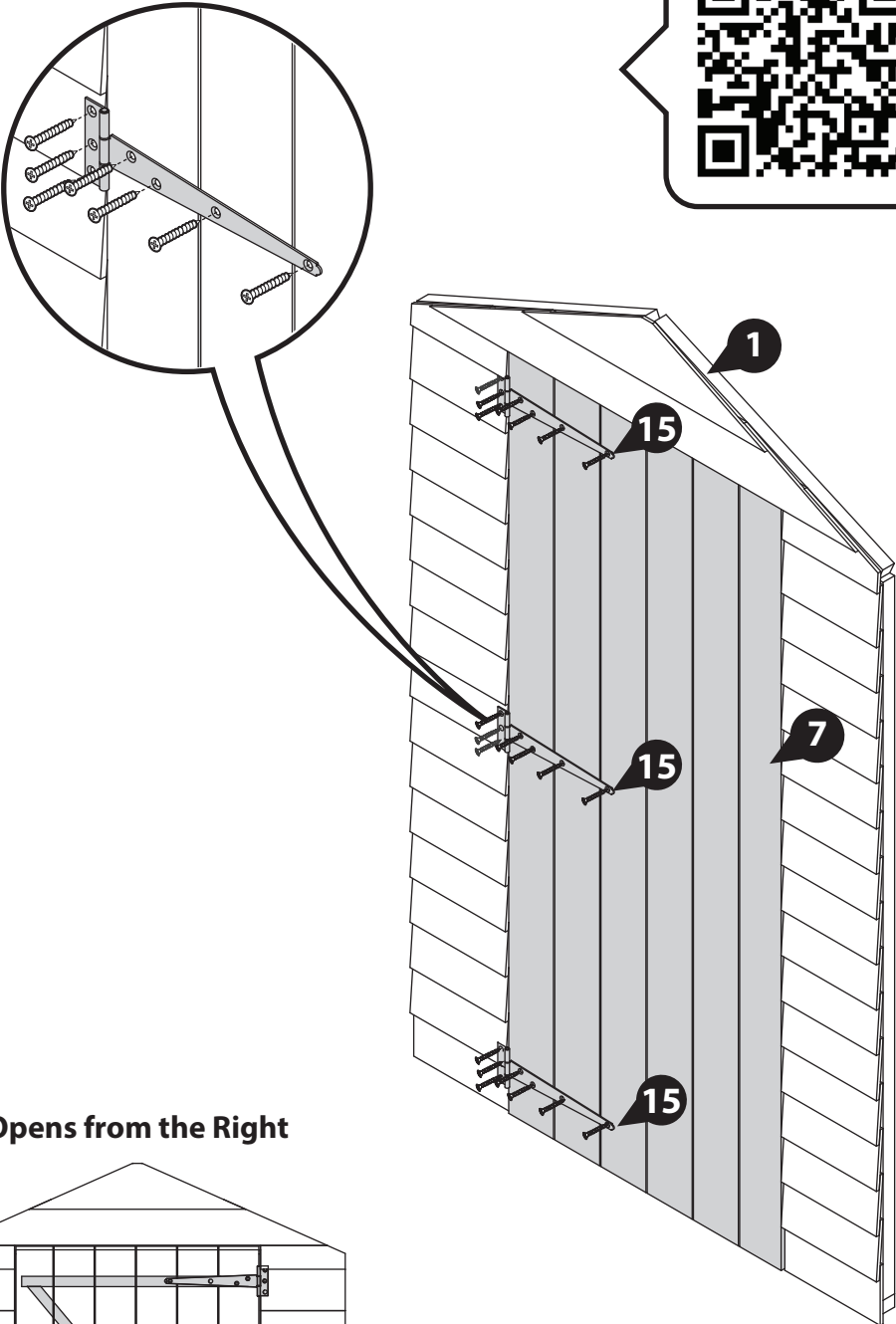

Opens from the Left

Opens from the Right

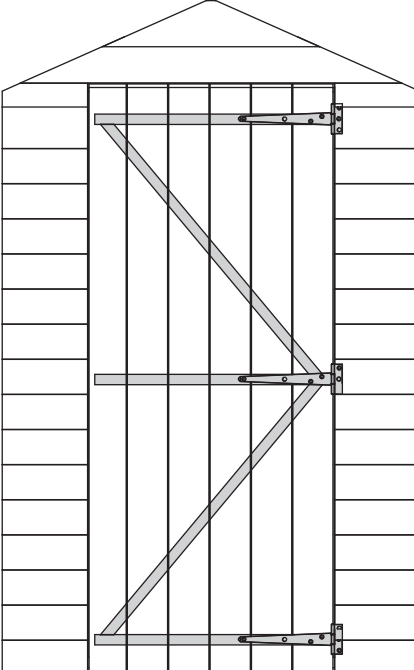
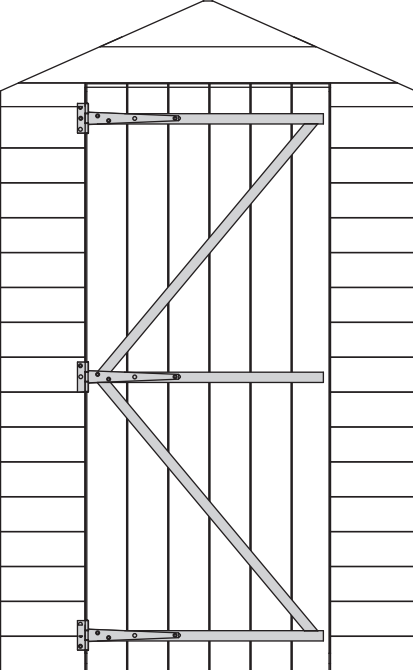

# Step 3

Parts needed - No. 2 QTY 1  
No. 3 (or 4) QTY 1

**\*\*Please note: Whether you have purchased the 'with windows' building or 'no windows' building, the panels are interchangeable. Decide which works best before assembly.\*\***

Locate the Back Gable (No. 2) and the Plain Panel (No. 3) on top of the floor, with the Gable sat on the inside of the Plain Panel, as shown.

Position the panels so there is equal spacing between the floor and cladding on all sides.

Fix the panels together at the corner using 3x50mm screws.

**Do not secure the panels to the floor until the roof is fitted.**

### 3x50mm Screws



**IMPORTANT: Pre-drill before fixing screws.**

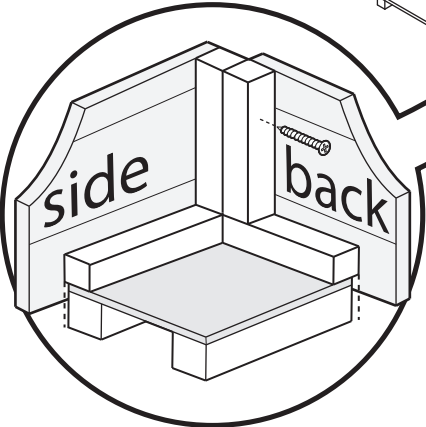
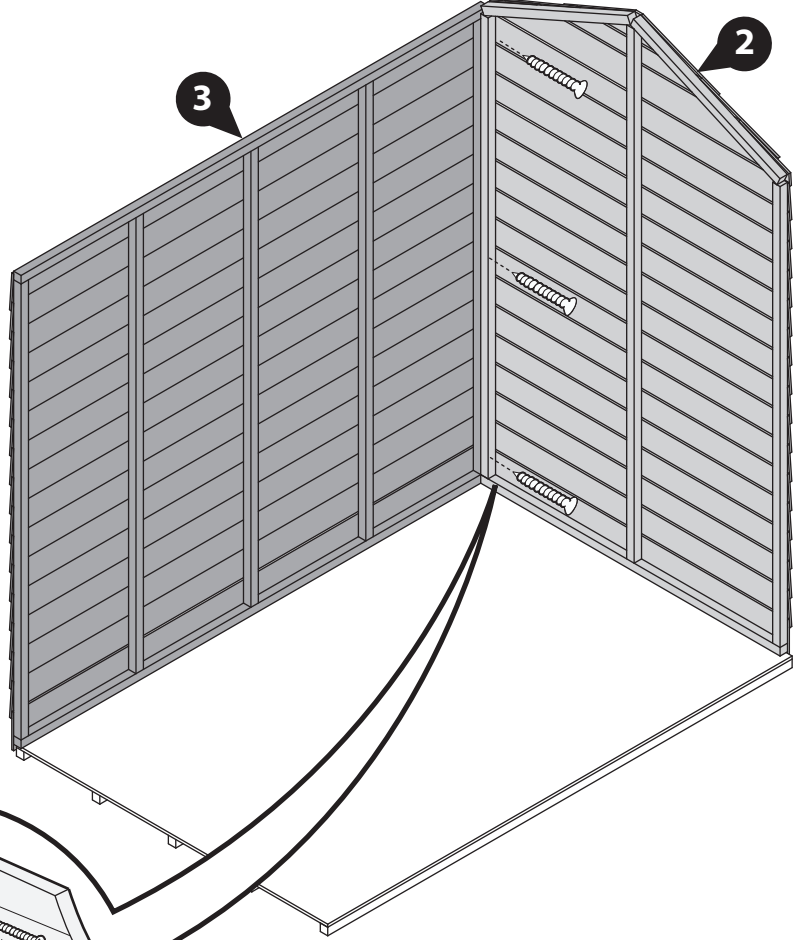

## Step 4

Parts needed - No. 1 QTY 1  
No. 4 (or 3) QTY 1

Locate the Window Panel (No. 4) (or Plain Panel) and the Back Gable (No. 2) on top of the floor, as shown.

Position the panels so there is equal spacing between the floor and cladding on all sides.

Fix the panels together at the corners using 3x50mm screws per corner.

Do not secure the panels to the floor until the roof is fitted.

9x50mm Screws



50mm screw

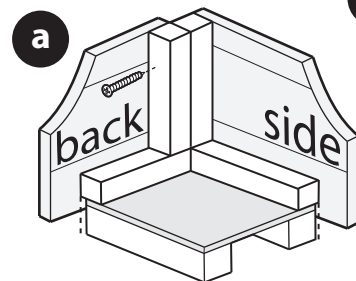

IMPORTANT: Pre-drill before fixing screws.

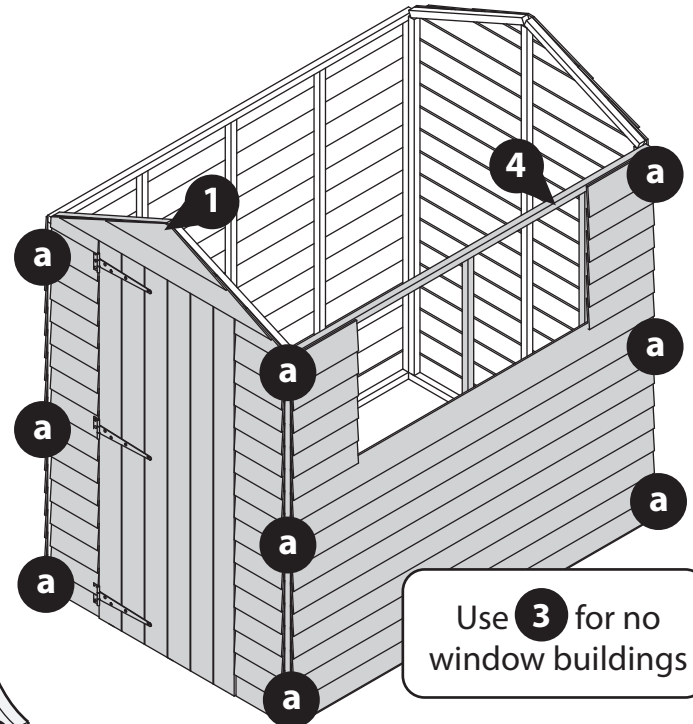

## Step 5

Parts needed - No. 12 QTY 1  
No. 20 QTY 1

Place the ridge bar (No. 12) in between the Door Gable (No. 1) and Back Gable (No. 2). Ensure the top corners of the ridge bar sit flush with the top points of the Gables.

Fix the ridge bar to the gable using one L-bracket (No. 20) for each end. Fix with 4x30mm screws per bracket.

8x30mm Screws



30mm screw

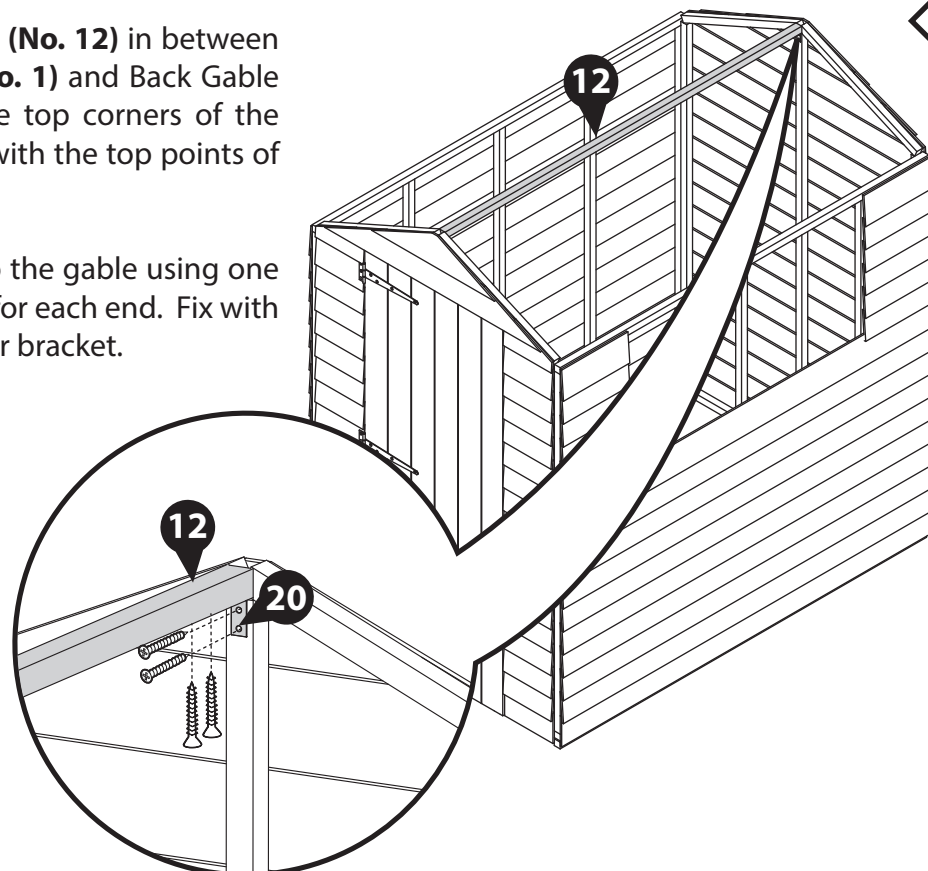

IMPORTANT: Pre-drill before fixing screws.



## Step 6

Parts needed - No. 6 QTY 2  
No. 13 QTY 4

a Fix the eaves frames (No. 13) to each roof sheet (No. 6) using 3x30mm screws per eave.

b Place the Roof Sheets (No. 6) on top of the building making sure the roof sheet meets the pointed edge of the Gables (No. 1 & 2) and it sits well on the top of the Ridge Bar (No. 12).

**\*\*The edges of the roof sheets must be flush with the outer cladding of the Gables (No. 1 & 2).\*\***

From the top, fix directly through the roof sheets (No. 6) and into the ridge bar (No. 12) below using 3x30mm screws per roof sheet.

It is essential that the ridge bar (No. 12) and the roof sheet (No. 6) pull together when fixed with 30mm screws. You may require another person pushing the ridge bar (No. 12) up from below to achieve this.

22x30mm Screws



30mm screw

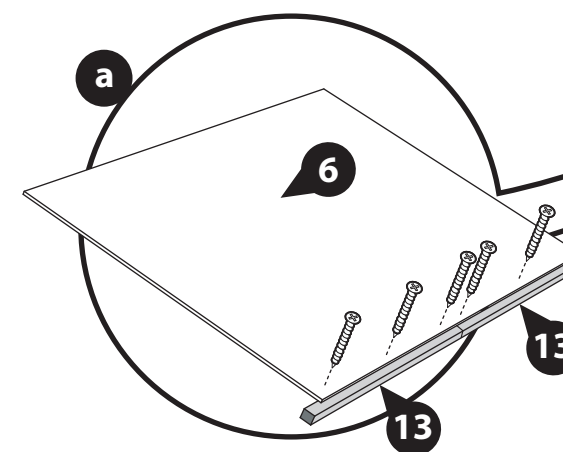

IMPORTANT: Pre-drill before fixing screws.

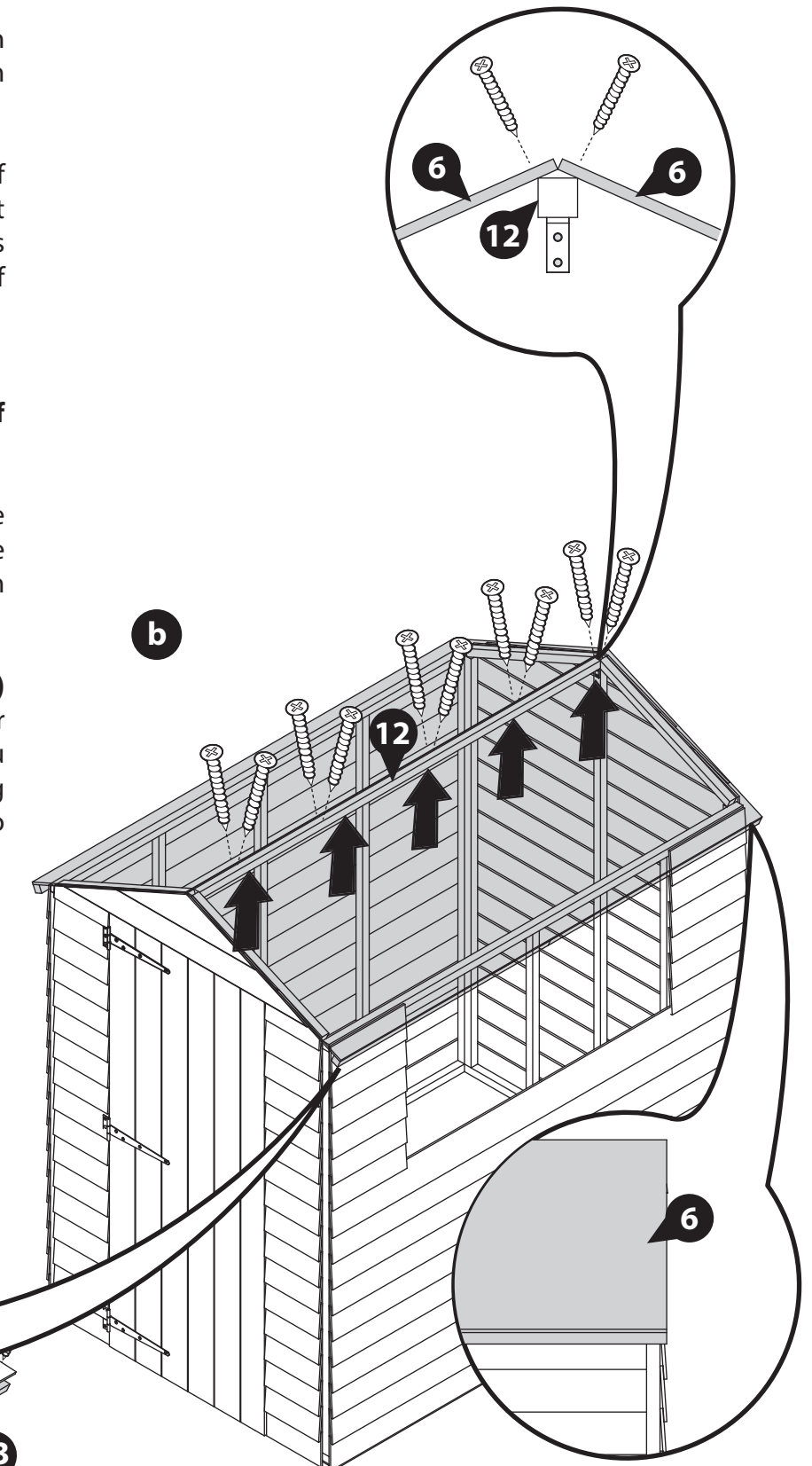



## Step 7

Secure the Roof sheets (**No. 6**) in place using 40mm screws. Ensure that the screws go through the sheet into the framing of the panels below.

Ensure there is no more than 300mm between each screw.

### 18x40mm Screws

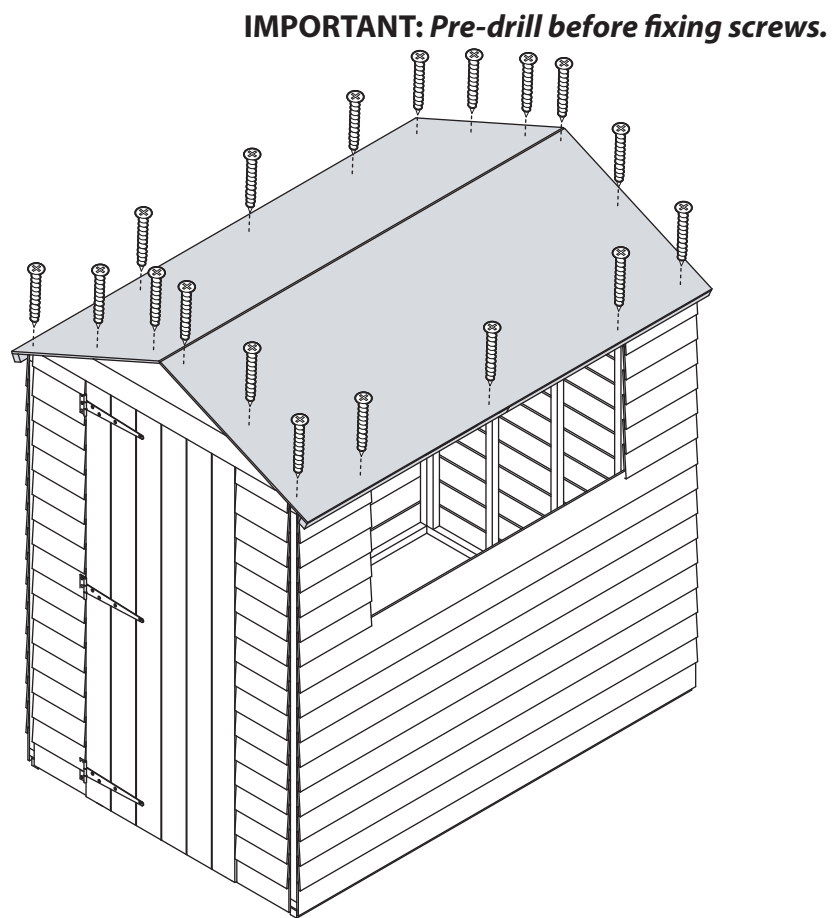

## Step 8

Once the roof is secured, fix the panels to the floor using 50mm screws.

Ensure the screws go through the panel into the floor framing.

### 18x50mm Screws

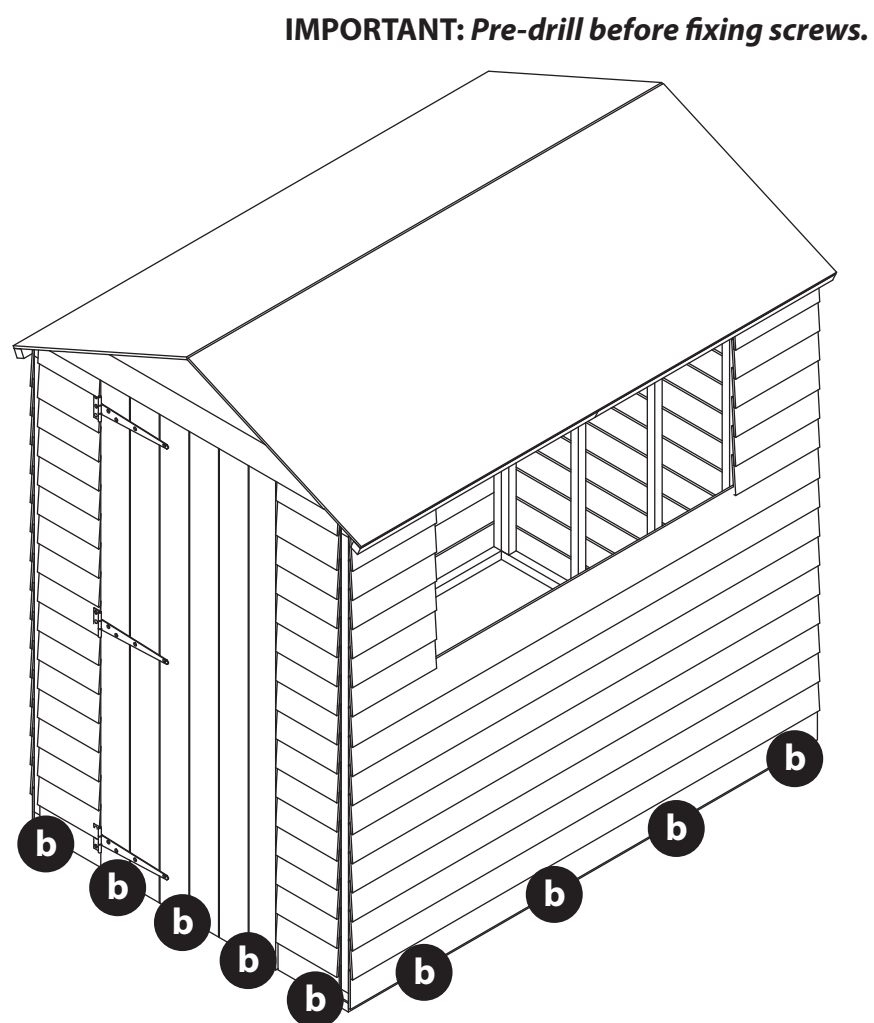
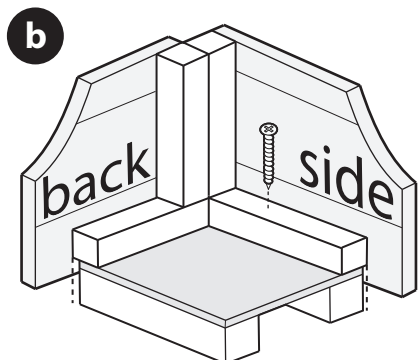

## Step 9

Parts needed - No. 18 QTY 1

Cut the felt (**No. 18**) into two sheets measuring: **1900mm (L) x 1000mm (W)**.

Lay the sheets onto the roof in the order shown in the diagram, ensuring there is 50mm overhang around the sides and that each sheet overlaps by 100mm.

Once the sheets are laid out secure them in place using felt tacks at 100mm intervals.

### 60 x Felt Tacks

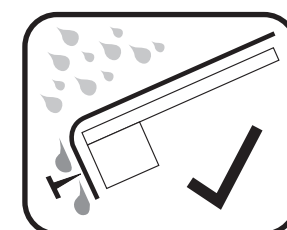
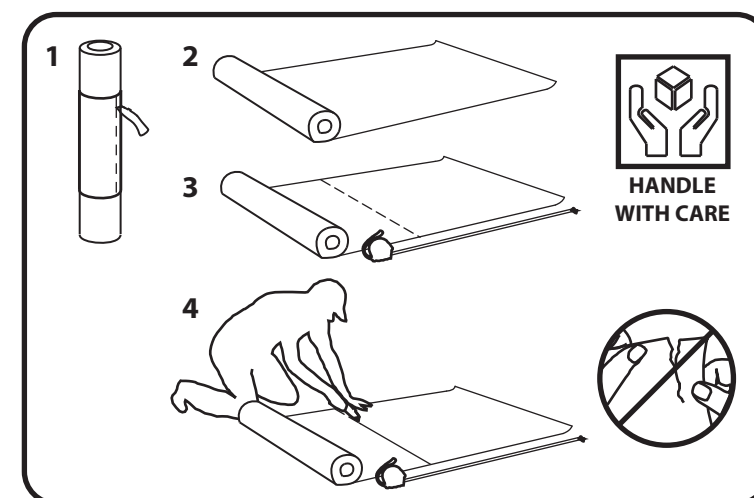
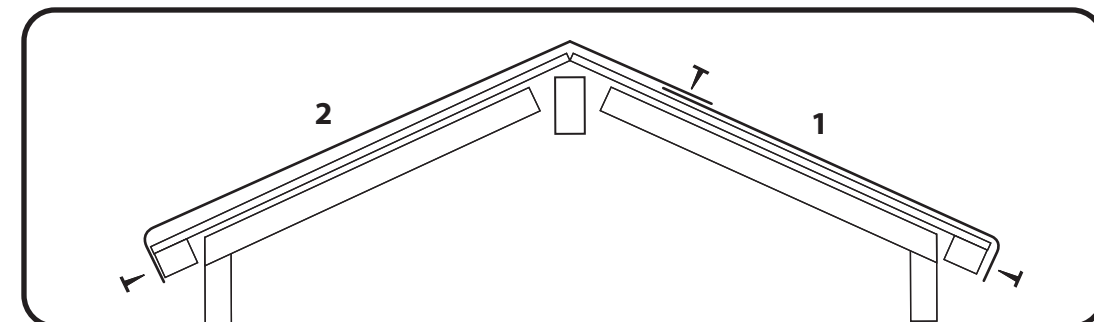
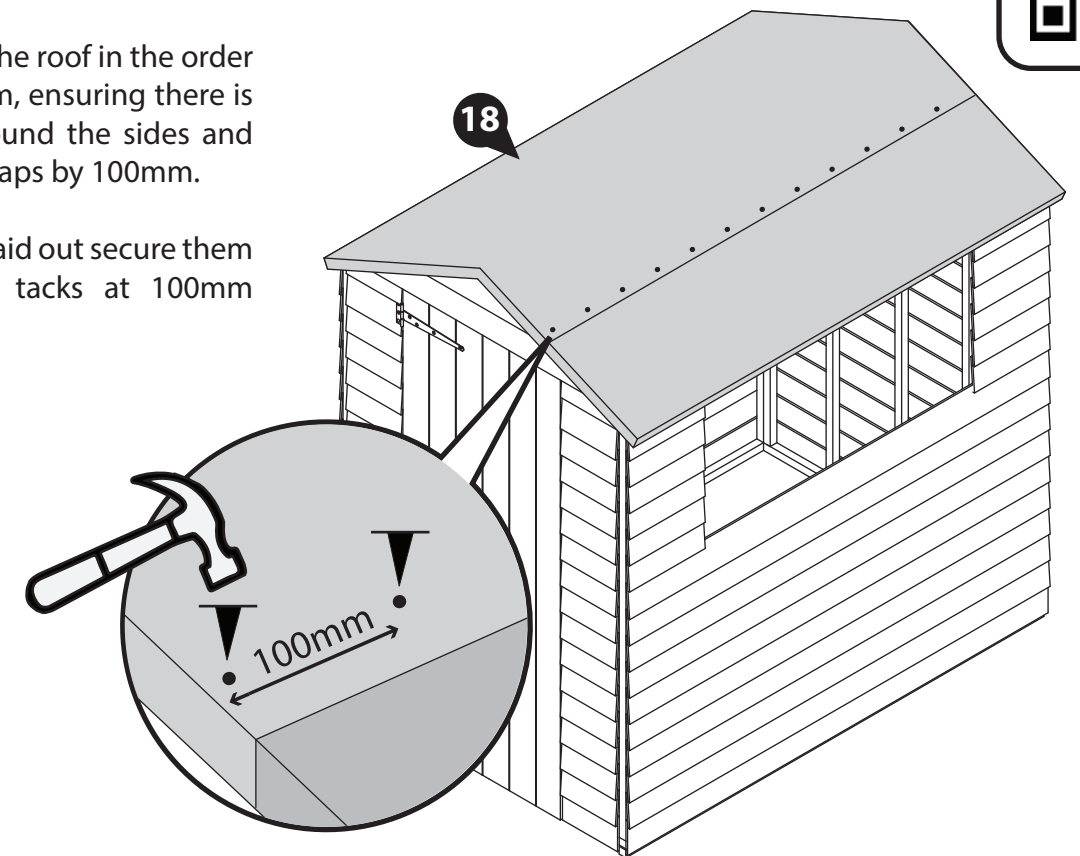



## Step 10

Parts needed - No. 10 QTY 4

Locate the Cover Trims (No. 10) to the corners of the building, as shown.

If needed, cut the trims to the required length and re-position at the corners.

Secure in place using 3x30mm screws per trim.

12x30mm Screws

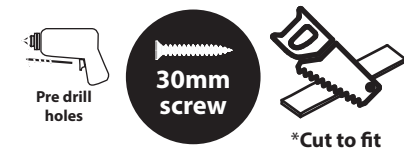

**IMPORTANT: Pre-drill before fixing screws.**

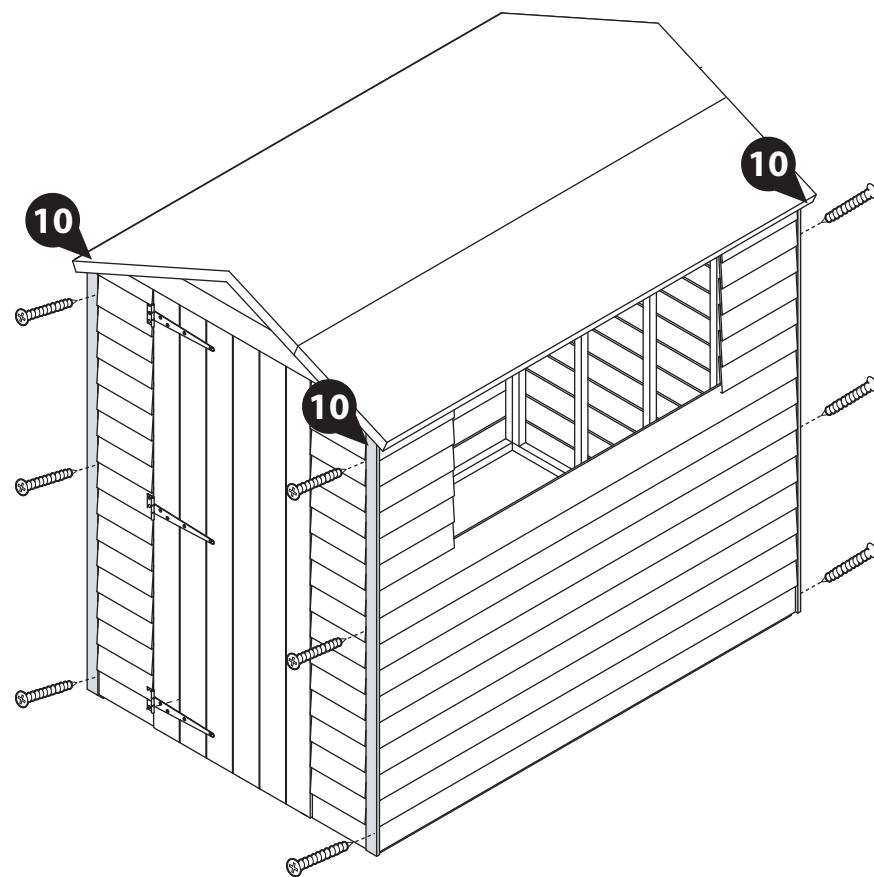

## Step 11

Parts needed - No. 8 QTY 4  
No. 14 QTY 2

Locate the Fascias (No. 8) onto the front and back of the roof, ensuring to trap the felt. Fix in place using 3x40mm screws per Fascia.

Position the Finials (No. 14) on top of the Fascias and fix in place using 2x40mm screws per Finial.

16x40mm Screws

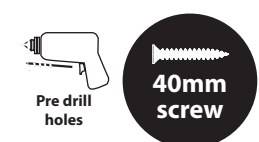

**IMPORTANT: Pre-drill before fixing screws.**

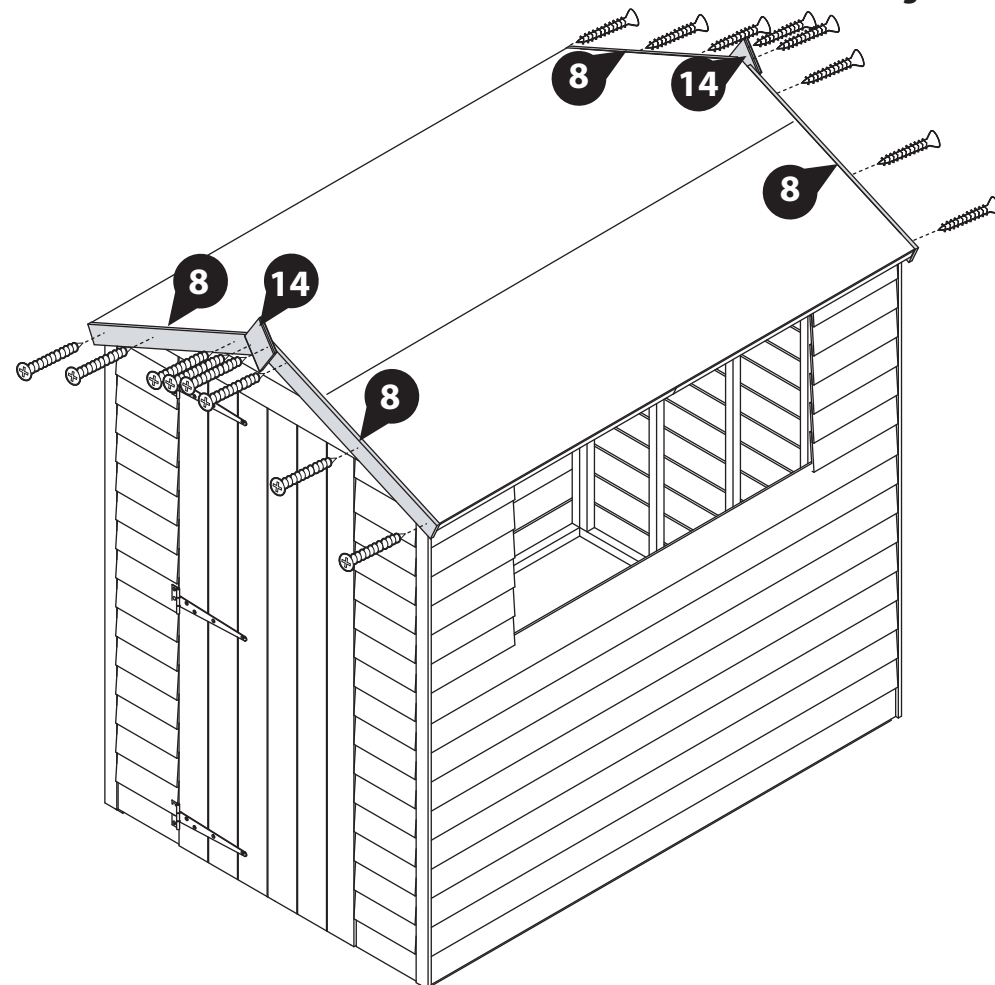

## Step 12

For the windowless version, skip to step 12.

Parts needed - No. 9 QTY 5  
No. 16 QTY 1  
No. 19 QTY

- Fix two window strips (No. 9) to the framing along the inside edge of the window gap using 3x30mm screws per strip.
- Place the plastic cill (No. 16) into the window panel, as shown. Fix in place using 3x30mm screws.
- Locate the styrene sheets (No. 19) on top of the window cill.

**\*\*When positioning the styrene sheets ensure there is an equal distance on all sides.**

**\*For added weather protection fit your windows using silicone sealant around the outside edges.**

- Attach the remaining three window strips (No. 9) to either side of the window and the centre. Secure into place using 3x30mm screws per strip.

18x30mm Screws

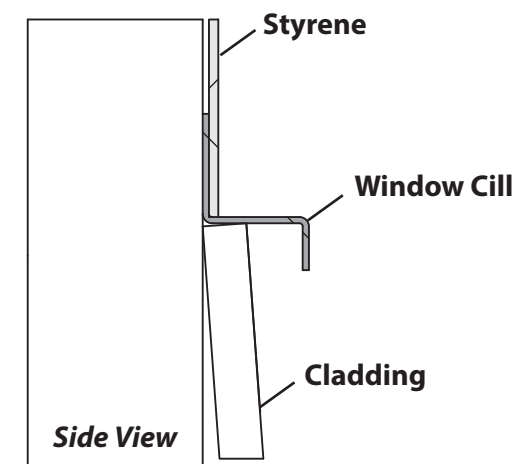

**IMPORTANT: Pre-drill before fixing screws.**

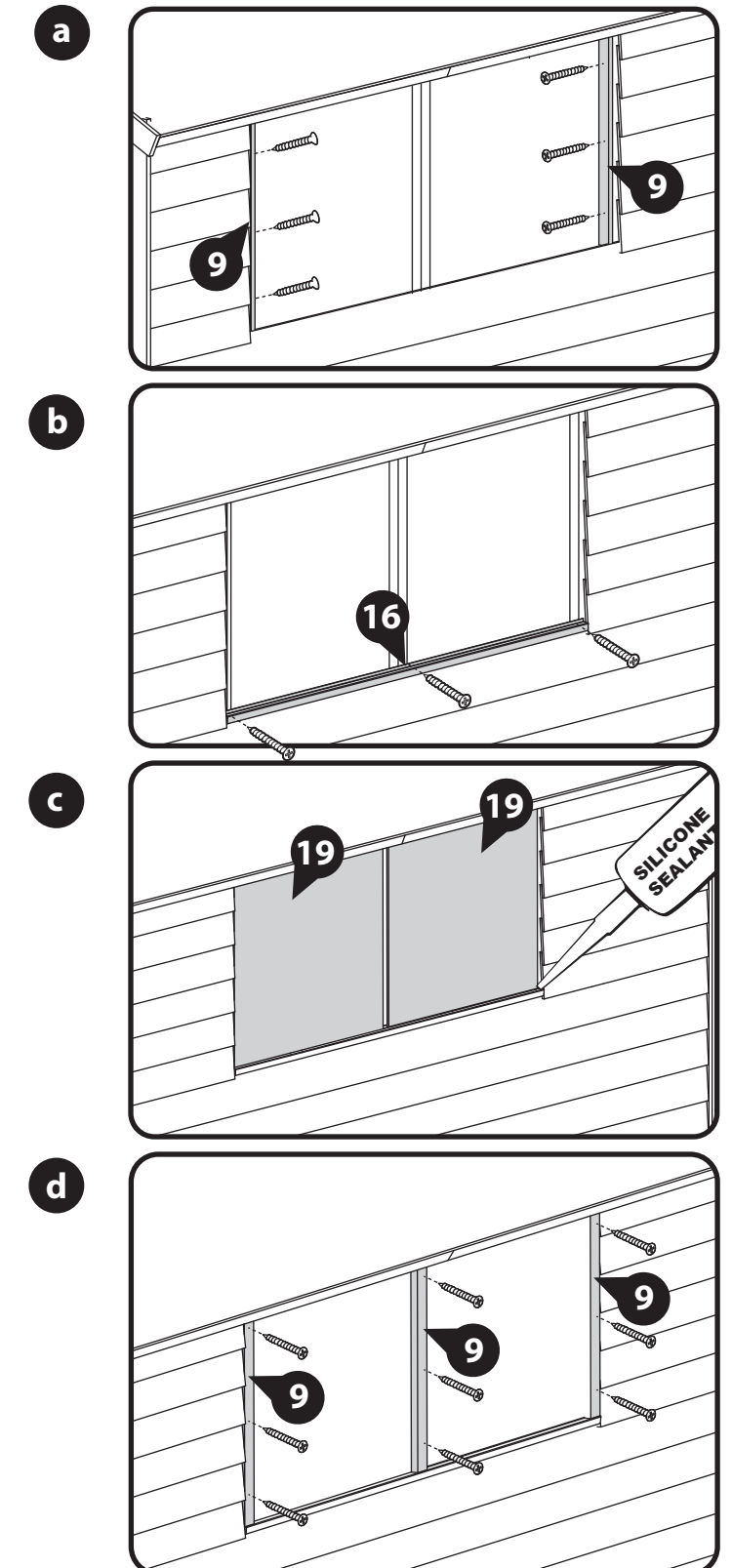

# Step 13

Parts needed - No. 11 QTY 2

Locate one Beading Strips (No. 11) onto either side of the inside of the door opening in the door panel.

Secure in place using 4x30mm per beading strip. Ensure that the screw is parallel with the door frame when fixing the strip, as shown in the close up view.

8x30mm Screws

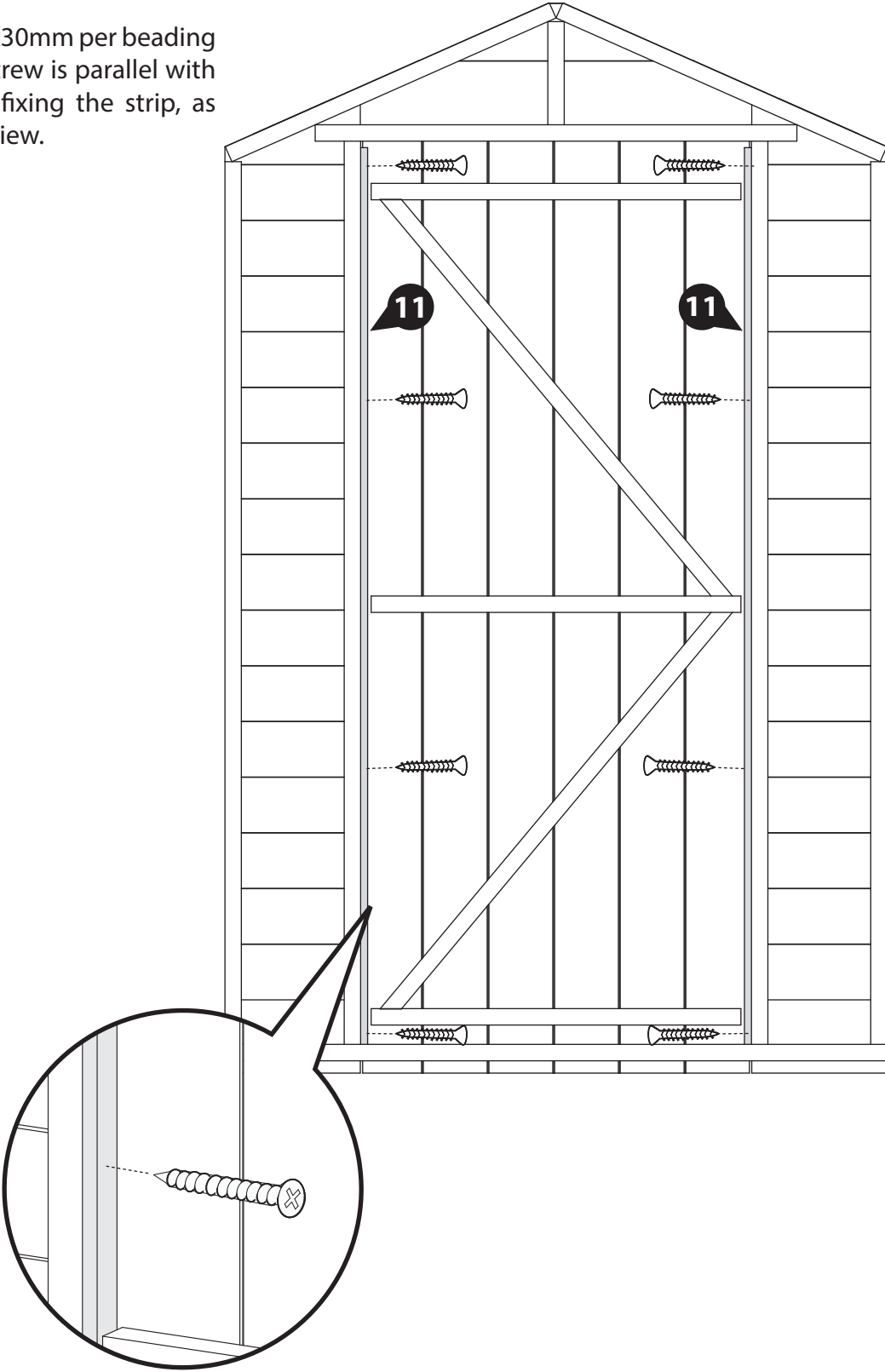

IMPORTANT: Pre-drill before fixing screws.

# Step 14

Parts needed - No. 21 QTY 1

Locate the Hasp and Staple (No. 21) onto the Door Gable and Door. Fix the Staple in place using 3x30mm screws, making sure that the screws go into the framing behind.

Check the Hasp (No. 21) is in line with the staple and screw into the Door using 4x30mm screws, making sure that the screws go into the framing behind.

7x30mm screws.

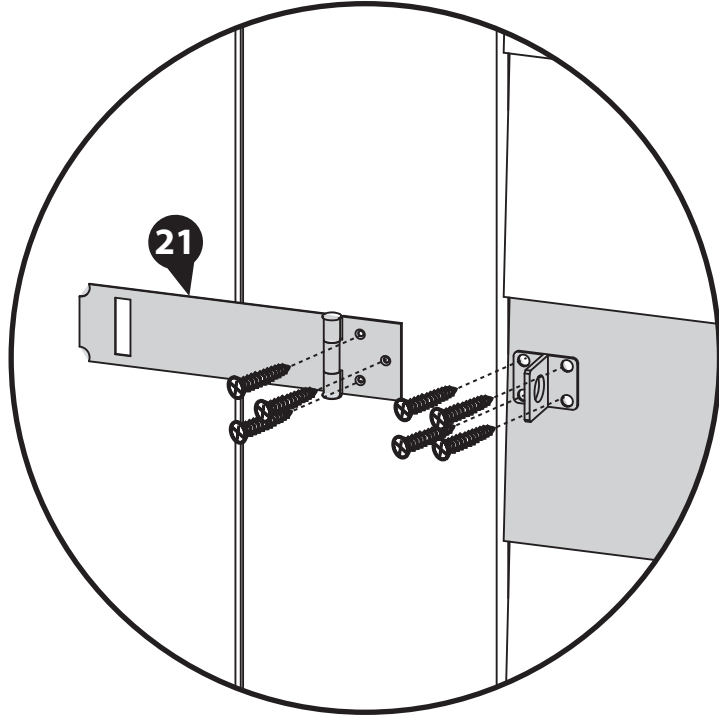

IMPORTANT: Pre-drill before fixing screws.

# Step 15

Parts needed - No. 17 QTY 2

Fix the Turn Buttons (No. 17) onto the top and bottom of the door gable (No. 1) using 1x30mm screw per Turn Button.

2x30mm Screw

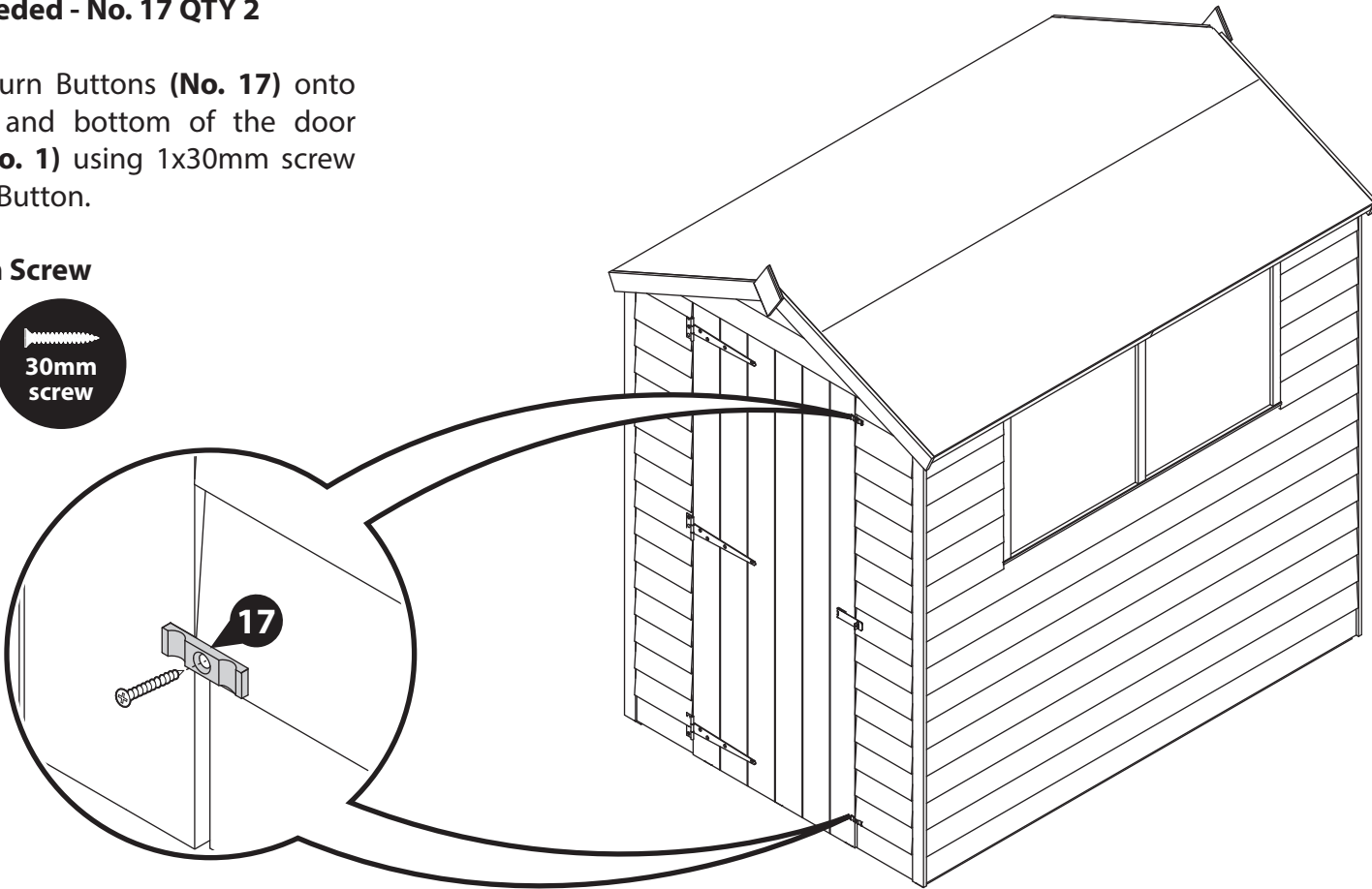

IMPORTANT: Pre-drill before fixing screws.

## Step 16

Once constructed, apply a preserving treatment and a waterproofing treatment to your garden building as soon as possible. This will help to protect your building and prevent decay.

See page 12 for a full guide and instructions.

### WITH WINDOW ONLY

Once fully treated, score around the protective covers on the glazing and carefully peel the coverings back.

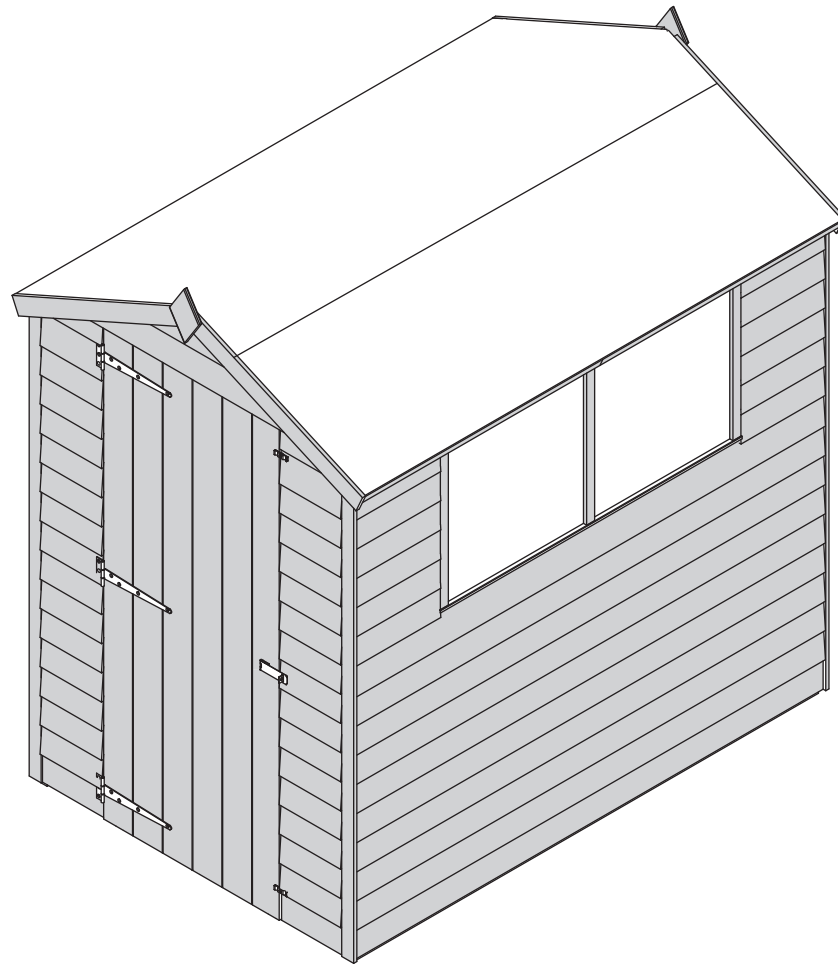

Apply treatment.



Score and peel.

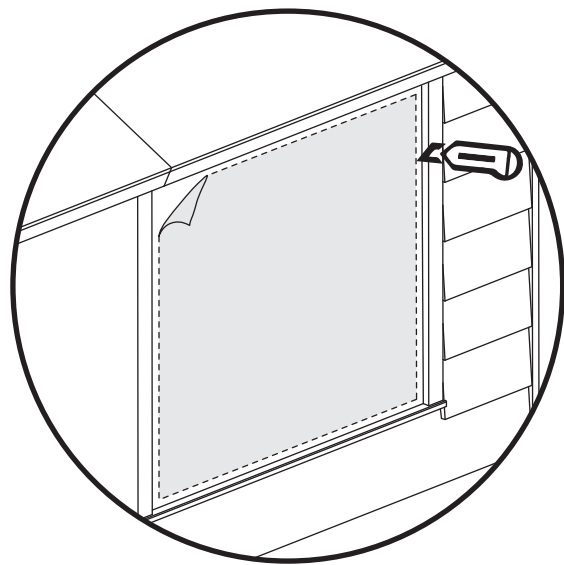

## LEAVE US A REVIEW...

Want to share your experience with us?  
Leave us a review on TrustPilot or Google.

Your reviews help other people find and trust our business, as well as helping to play an important role in our growth and improvement!

## TREATING YOUR GARDEN BUILDING

Preservation of wood that's outdoors is vital. A little early care will help protect your garden building, improve its appearance and ensure maximum longevity. Insects, moisture, salt, and changing weather can have dramatic effects on the stability and appearance of your garden building. Once your building is installed, you've checked it over and you're happy with it, you can take a few basic precautions to prepare it for the elements. Treating your garden building helps prevent decay and, by repelling water, discourages the growth of moulds and fungi that could jeopardise the structural integrity of the wood.

**Dip Treated buildings** - Require a preservative treatment to protect against rot and decay and a waterproof treatment to prevent water ingress  
**Pressure Treated buildings** - Require a waterproof treatment to prevent water ingress  
**Log Cabins/Insulated Garden Rooms** - Are supplied untreated and require a preservative and waterproofing treatment.



**ANY QUESTIONS?**  
Scan the QR code to contact us via our customer portal.

To apply a preservative and water proofing treatment (pressure treated products do not require a preserver), follow the manufacturer's instructions but in principle, stick to the following steps:

- ✓ Weather permitting, ensure to treat your garden building within 14 days of installation.
- ✓ Wear latex or rubber gloves, eye protection and (if spraying) a mask.
- ✓ Prepare the wood, by sanding down any ridges or inconsistencies in the wood, smoothing out knots and end-cuts.
- ✓ Choose a dry day to treat your garden building. If you're spraying rather than brushing paint on, avoid a windy day.
- ✓ Be sure you can safely reach all the sections you need to paint - and if you need a ladder, make sure it's safely positioned before climbing. Lay dust sheets around to avoid paint splatters on your base or surrounding plants.

- ✓ Tape around windowpanes to avoid smears when you're painting the frames.
- ✓ Keep pets and small children out of the way. The last thing you want is to have fur on your garden building paint, or little painted footprints all over your garden and home.
- ✓ Fill any gaps in the building's body with caulk or wood filler to prevent water and draughts getting in. Silicone based caulk is flexible and will move with the timber when temperature and humidity change. Allow to dry completely before treating. A handy tip for finding gaps is to go into your garden building and look for light leaking through joins and frames. If light gets in, then so will water.
- ✓ Liberally apply at least two coats of the treatment products with a brush or spray, taking care to allow the first coat to completely dry before applying the second.
- ✓ Make sure the solution permeates the whole of the surface area, especially around natural cracks, end cuts and nail/screw holes.



APPLY WOOD TREATMENT  
**IMMEDIATELY**  
AFTER ASSEMBLY





## 1 Perimeter

Check around the perimeter of your product to ensure there are not trees or plants that are in contact with or overhanging the building. This can affect airflow and overhanging trees, or branches can damage the roof, it is advised to keep plants at a distance.

## 2 Repair

Inspect the interior and exterior of the product to look for splits, cracks, and holes. Although this is a natural occurrence it can be prevented. A wood filler can be used to close the splits, cracks, and holes.

## 3 Roof

Check your roof regularly for tears, splits, damaged wood and fallen debris. If you notice any of this immediate repair is critical.

## 4 Doors & Windows

Expansion and contraction can cause doors and windows to stick or become difficult to open. Small adjustments to the hinge position can be made to the doors and windows to allow free movement.

## 5 Oil

Hinges can seize up over time, apply lubricant to the hinges and locks annually.

## 6 Screws & Bolts

It is advised to check all screws and bolts and tighten any loose you might find. For log cabins specifically the storm braces will require loosening. During humidity and temperature changes (seasons) to allow expansion and contraction to prevent gaping, twisting, popping, and warping.

## 7 Wash

At least once a year, give the outside of your building a good wash, to remove cobwebs, leaves, or any other dirt that may accumulate on the exterior.

## 8 Airing

Airing your product regularly prevents the build up of condensation which can cause the timber to warp, bow, boards to pop, distortion, rot and mould. Condensation can build up over time or daily, it is caused by a rise and fall in temperature.

Excessive moisture levels within your building can cause water to collect on the roofs, walls and floors internally. Leaving doors and windows open regularly can help combat the natural moisture build up.

## 9 Clean & Tidy

It is good practice to clean the inside and outside of your product regularly. Clear out the contents, sweep the floor, remove dirt and cobwebs. Check for areas of damp and investigate the cause to remove and prevent future occurrences. Check the ground around your product for build up of debris such as leaves, remove and ensure there is clear ventilation underneath the floor.

### Additional Playhouse Maintenance:

It is recommended that the following checks and maintenance are carried out at the beginning of each season as well as at regular intervals during the usage season.

- Check all nuts /bolts/ screws for tightness and tighten when required.
- Check for movement / opening of wood giving rise to protrusion of nail heads and tips.
- Check hinges.
- Replace defective parts in accordance with the manufacturers instructions.
- Check any crossbeams, suspensions and anchors.
- If a swing is included; check the swing seat, chains and ropes.

**IF THESE CHECKS ARE NOT CARRIED OUT THE ACTIVITY TOY COULD BECOME A HAZARD**

All our garden buildings have been designed and manufactured with care and attention to be the perfect addition to your outdoor space. To ensure you do get the best out of your new garden building and to increase the longevity we advise that you follow the product instructions and our manufacturer's recommendations as detailed below. Thank you for choosing a Mercia Garden product!

## 1 Choosing the most suitable location for your garden building...

A minimum of 60cm should be left around the perimeter of your garden building to allow access for maintenance, annual treatment and to allow air flow around the building.

Where possible you should avoid placing your garden building underneath large trees to prevent the tree causing damage to the building.

## 2 Preparing the base for your garden building...

All our buildings must be built on a firm, level base to ensure the longevity of the building and prevent the wood from distorting. We recommend either concrete, concrete slabs or a wooden base, such as our 'Portabase'.

The base should be slightly smaller than the external measurement of the building, i.e. the cladding should overlap the base, creating a run off for water and preventing water from pooling underneath the building.

We also recommend that the floor of the garden building is a minimum of 25mm above the surrounding ground level to avoid flooding.

## 3 After installation...

Once your garden building has been installed, it will need to be treated within 14 days (weather permitting) and annually to prevent the timber from deteriorating and to waterproof it. This is required to maintain the anti-rot guarantee.

Dip Treated buildings - Require a preservative treatment to protect against rot and decay and a waterproof treatment to prevent water ingress.

Pressure Treated buildings - Require a waterproof treatment to prevent water ingress.

Log Cabins/Insulated Garden Rooms - Are supplied untreated and require a preservative and waterproofing treatment.

We also recommend using a silicon sealant on the inside and outside of the windows as soon as possible after assembly and treatment to fully seal the windows.

Roofing felt/covering should be checked annually and replaced or fixed accordingly.

## 4 General maintenance and wood characteristics

As wood is a natural material it may be affected by the following:

Shrinkage and warping - The timber used in the construction of your garden building will have retained some of its natural moisture content. The moisture content of the timber will vary, depending upon prevailing environmental conditions, which will result in the components either naturally expanding or contracting. As the components dry out, shrinkage may occur. A good waterproofing treatment from the start is the best protection to minimise the effect of moisture loss/intake.

In extended periods of very warm weather getting some moisture to the building will help the overall balance. You can do this by spraying it down lightly with a garden hose. In contrast, after snow fall try to remove the snow as best as possible from the roof to prevent moisture intake and to remove the extra weight.

**Top tip** - using a garden brush will help you to reach the highest part of the building to remove snow and any debris left from bad weather.

Damp and mould - During the winter months, cold and damp conditions can result in an increased amount of moisture within your garden building, especially when used infrequently. Condensation can form on the timber and other items stored within your garden building. If left this moisture is likely to cause mould and mildew.

To prevent the build-up of moisture, we recommend leaving the door or windows of your building open from time to time, to allow the fresh air to circulate. We also advise against storing wet or damp items in your garden building as this will also increase the level of moisture in the building. If mould or mildew does start to form within your building we recommend using an anti-mould cleaner to remove it and to prevent it spreading, which if left untreated could permanently damage your garden building.

Splits, cracks and knots - You may notice small splits and cracks in some components or holes may appear where knots shrink and fall out. This will not affect the structure of your Garden building however, if you wish to fill them this can be easily done using any good quality wood filler.

Sap - is naturally occurring in wood and may appear in some boards of your garden building. If you wish to remove the sap, we advise waiting until it is dry and then using a sharp knife to carefully remove it. If the removal of the sap causes a hole in the timber, we recommend using a good quality wood filler to fill it.

For more handy hints and tips on how to care and maintain your garden building please refer to the MGP Customer Portal at [www.mgplogistics.co.uk](http://www.mgplogistics.co.uk)

### Any further questions?



Contact our Customer Service Team via the MGP Customer Portal at: [www.mgplogistics.co.uk](http://www.mgplogistics.co.uk)

## 1

### Manufacturer's Warranty

All Mercia Garden Products are supplied with a 1 year warranty on all parts against manufacturing defects.

This warranty does not cover movement, warping or splitting of timber products over time.

This warranty will be voided if any of the following occur:

1. The building has been customised or modified/adapted in any way.
2. The person claiming is not the original purchaser of the building.
3. Any damage has been caused by or as a result of misuse.
4. The building has not been maintained and cared for in accordance to our advisories and manufacturer's recommendations.
5. The building has not been treated annually or as per the manufacturer's recommendations, please ensure receipts are kept to validate this claim.
6. The building has not been erected, fitted or installed as per the supplier instructions.
7. The building has not been erected on a suitable sized firm flat, solid level concrete/slab base or placed on pressure treated bearers.
8. The building is or has been placed with 2 feet (600mm) of any obstructions (walls, trees, plants, fences etc.) which can allow moisture to penetrate the timber.
9. The roofing felt has been incorrectly fitted or damaged, allowing water ingress, or has not been properly maintained.
10. Any windows and joints have not been sealed, inside and out, with silicone or other watertight sealant.
11. Any timber has been cut, pierced or drilled without subsequent application of approved cut-end treatment.

REGISTER FOR YOUR  
**10 YEAR**  
**ANTI-ROT**  
GUARANTEE TODAY



[www.mgplogistics.co.uk](http://www.mgplogistics.co.uk)

## 2

### Anti-rot Guarantee

Mercia Garden Products offer a 10 year anti-rot guarantee on all dip treated (a preparatory treatment) and 15 years on all pressure treated products. This guarantee covers solid timber against rot, decay, blue stain and insect attacks.

To validate the guarantee, the building must be treated (as detailed within manufacturer's recommendations) within 14 days (weather permitting) of assembly and annually thereafter.

This guarantee does not cover movement, warping or splitting of timber products over time.

This guarantee will be voided if any of the following occur:

1. The building has been customised or modified/adapted in any way.
2. The person claiming is not the original purchaser of the building.
3. Any damage is caused by or as a result of misuse.
4. The building has not been maintained and cared for in accordance to our advisories and manufacturer's recommendations.
5. The building has not been treated annually or as per the manufacturer's recommendations, please ensure receipts are kept to validate this claim.
6. The building has not been erected, fitted or installed as per the supplier instructions.
7. The building has not been erected on a suitable sized firm flat, solid level concrete/slab base or placed on pressure treated bearers.
8. The building is or has been placed with 600mm of any obstructions (walls, trees, plants, fences etc.) which can allow moisture to penetrate the timber.
9. The roofing felt has been incorrectly fitted or damaged allowing water ingress, or has not been properly maintained.
10. Any windows and joints have not been sealed, inside and out, with silicone or other watertight sealant.
11. Any timber has been cut, pierced or drilled without subsequent application of approved cut-end treatment.