

**02DTSHOA0705LFD3WBF-V1-PEFC**  
**7X5 Double Storey Playhouse.**



**WARNING: Only for domestic use**  
 Not suitable for children under 36 months due to small gaps and danger of falling from heights.  
 To be used under direct supervision of an adult



**WARNING**

- ONLY SUITABLE FOR DOMESTIC USE.
- TO BE USED UNDER DIRECT SUPERVISION OF AN ADULT.
- THIS PRODUCT SHOULD NOT BE MODIFIED IN ANY WAY. ANY MODIFICATIONS SHOULD BE DETERMINED BY THE MANUFACTURER AND CARRIED OUT ACCORDING TO THE INSTRUCTIONS.
- DO NOT ALLOW YOUR CHILD TO PLAY WITH ANY COMPONENT PARTS PRIOR TO ASSEMBLY.
- MAX AGE OF 14 YEARS.
- THIS TOY IS FOR OUTDOOR USE ONLY.
- USE A WATER BASED TREATMENT THAT IS EN71 TESTED.

**CAUTION**

Wood is a natural product and can change post manufacture. So despite every effort being made to ensure the material used are cut and machined to a clean and smooth finish, care must be taken when handling the product and preparing for use by your child.



Any areas of concern, in the play areas, can be rubbed over with sandpaper to achieve a smoother finish. Alternatively, call the customer service department who will be happy to arrange replacement panels/parts.



All buildings should be erected by at least two adults.  
**DO NOT ALLOW CHILDREN TO ASSIST.**

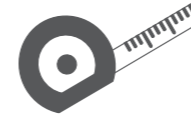

For ease of assembly, you will need a tape measure to check dimensions of components.



**2mm Drill bit**  
**12mm CSK**

To prevent damage during assembly, you **MUST** pilot drill all screw holes and ensure all screw heads are countersunk.



Winter = High Moisture = Expansion  
 Summer = Low Moisture = Contraction

**Screws & Nails**

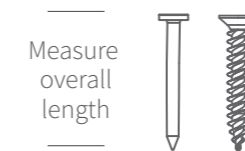

Measure overall length

**Bolts**

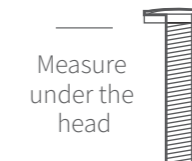

Measure under the head

To identify the fixings required for each step use a measuring tape.

**\*\*Protim Aquatan T5 (621)\*\***

Your building has been dip treated with Aquatan.

Aquatan is a water-based concentrate which is diluted with water, the building has been treated by the correct application of Aquatan solution and then allowed to dry.

Aquatan is a decorative finish to colour the wood, which is applied industrially to timber fence panels and garden buildings.

Aquatan undiluted contains: boric acid, sodium hydroxide 32% solution, aqueous mixture of sodium dioctyl sulpho-succinat and alcohols: 2, 4, 6-trichlorophenol.

In all instances for assistance with your product, please contact us via our customer portal: <https://www.mgplogistics.co.uk/>

Mercia Garden Products Limited,  
 Sutton On Trent,  
 Newark,  
 Nottinghamshire,  
 NG23 6QN



**BEFORE YOU START PLEASE READ THE INSTRUCTIONS CAREFULLY**

- Check the pack and make sure you have all the items listed in the parts list provided.
- When you are ready to start, make sure you have the right tools at hand (not supplied - see the equipment list on next page).
- Ensure there is plenty of space and a clean dry area for assembly.
- Ensure you have enough time to build the product to ensure the building is water tight.

**TIMBER**

As with all natural materials, timber can be affected during various weather conditions. For the duration of heavy or extended periods of rain, swelling of the wood panels may occur. Warping of the wood may also occur during excessive dry spells due to natural processes. Unfortunately, these processes cannot be avoided but can be helped. It is suggested that the outdoor building is sprayed with water during extended periods of hot weather and sheltered as much as possible during rain or snow.

Once your garden building has been installed it will need to be treated within 14 days (weather permitting) and annually to prevent the timber from deteriorating and to waterproof it. This is required to maintain the anti-rot guarantee.

Dip Treated buildings - Require a preservative treatment to protect against rot and decay and a waterproof treatment to prevent water ingress.

**POSITIONING YOUR PLAYHOUSE**

When thinking about where the building and where the base is going to be constructed: Ensure that there will be access to all sides for maintenance work and annual treatment.

We recommend a **minimum space of 2m around a playhouse**, away from any structure or obstructions such as fences, garages, houses, overhanging branches, washing lines or electrical wires.

It is recommended that the position of the Playhouse is **not in direct sunlight**.

**Activity toys such as swings and slides for towers shall not be installed over concrete, asphalt or any hard surface.**

Whilst all products manufactured are made to the highest standards of safety and in the case of childrens products independently tested to EN71, we cannot accept responsibility for your safety whilst erecting this product.

**BUILDING A BASE**

Ensure the base is level and is built on firm ground, to prevent distortion, checking with a spirit level. Refer to diagrams for the base dimensions. The base should be slightly smaller than the external measurement of the building, i.e. The cladding should overlap the base, creating a run off for water. It is also recommended that the floor be at least 25mm above the surrounding ground level to avoid flooding.

**TYPES OF BASE**

- Concrete 75mm laid on top of 75mm hard-core.
- Slabs laid on 50mm of sharp sand.
- Wooden base.

Look for the symbols and follow the safety guidelines below.



Ensure screw heads are subflush and sand down any splinters created.



Ensure the screws are fixed squarely and do not protrude.



50kg per user



12mm gap surrounding the door.

### TO DO LIST

- Find a suitable location to build *(see front cover for further information)*.
- Build a base *(see front cover for further information)*.
- Check the base is flat, level, clear of debris and has 600mm clearance on all sides.
- Check you have the required equipment.
- Check you have all the product items listed *(if you have missing or damaged parts please contact the customer services department, see front cover for contact details)*.
- Install the product as per the step by step instructions within this pack.
- Prepare the product ready for treatment.
- Apply a preserving and a waterproofing treatment within 14 days *(weather permitting)* of installation.
- Register for your anti-rot guarantee *(scan the QR below)*.
- Tidy the build area and dispose of any remaining parts responsibly.
- Maintain your building *(see the manufacturers recommendations at the back of this pack)*.



REGISTER FOR YOUR  
**ANTI-ROT**  
GUARANTEE TODAY

PLEASE SCAN HERE:



### EQUIPMENT LIST

- Hammer
- Flat Head Screwdriver
- Drill
- Drill Bit Set
- Phillips and Slotted Bit Sets
- Tape Measure
- Hand Saw
- Spirit Level
- Ladders/Steps
- Stanley Knife/Cutting Tool
- Sand Paper
- Gloves
- Silicone (For Windows Only)
- Wood Filler (Optional)
- Timber Preservative Treatment
- Timber Water Proofing Treatment
- Treatment Mixing Stick
- Paint Brush/Sprayer/Roller

### NEED EXTRA SUPPORT

If you are unsure that your base preparation will be suitable, please contact us on 01636 821215 to discuss this further.

Alternatively, you can visit our website or MGP Logistics Online Portal for some further shededucation.

Website:  
<https://www.mercia garden products.co.uk/shededucation>

MGP Logistics Online Portal:  
<https://www.mgplogistics.co.uk/>

Here you will find plenty of useful information that'll help with most pre-installation and maintenance queries.

PLEASE SCAN HERE:



### ANY QUESTIONS?

Scan the QR code to contact us via our customer portal.

### NOTES

## ACCESSING VIDEO GUIDES...

Some steps within this set of instructions come with an added video guide for your convenience. These can be accessed via the QR code and used to aid you in constructing that step. See below for how to use.

You can also find all the videos on our youtube channel:  
<https://www.youtube.com/@merciagardenproducts8716/videos>

### 1. Find the QR code within the instruction step...

#### Step.....

Parts Needed- No. QTY 1  
No. QTY 1  
No. QTY 1



Within the instruction step, there will be an icon in the top right that has a QR code in. This is where the video can be accessed from.

*Please note: not every step has a video guide.*

### 2. Open camera app...

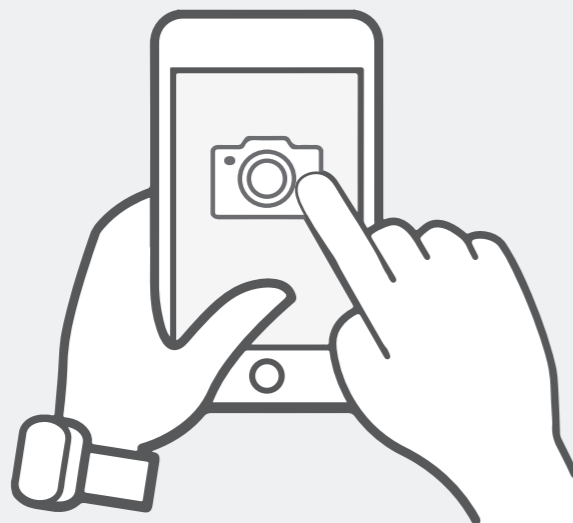

On your personal smart device (phone, tablet etc), open your camera app or QR code scanner app.

## ACCESSING VIDEO GUIDES...

### 3. Scan QR code...



To scan the QR code, hold the camera over the QR code so that it can be seen on the screen. Once the QR code has been registered, follow the prompts on your device to open the video. (This will vary depending on your device.)

*Please note: Ensure to use the back camera of your smart device as this will scan the QR code more accurately.*

### 4. Watch the video...



The video guide will now be displayed on your smart device.

**Disclaimer:** The building constructed in the video guides may differ slightly to your chosen building. Please ensure to read your instructions carefully to avoid error.

## Playhouse Options:

Take a look at the different playhouse options below which refers to the product code combinations used to create each playhouse.

Model	Product Codes
<b>7x5 Playhouse</b> <i>SI-002-001-0015</i>	02DTSHOA0705LFD3WBF-V1-PEFC ( <i>Playhouse</i> )
<b>7x6 Playhouse With Veranda</b> <i>SI-002-001-0107</i>	02DTSHOA0705LFD3WBF-V1-PEFC ( <i>Playhouse</i> ) 02DTPAVP0701-V1-PEFC ( <i>Veranda Pack</i> )

**7x5 Playhouse**

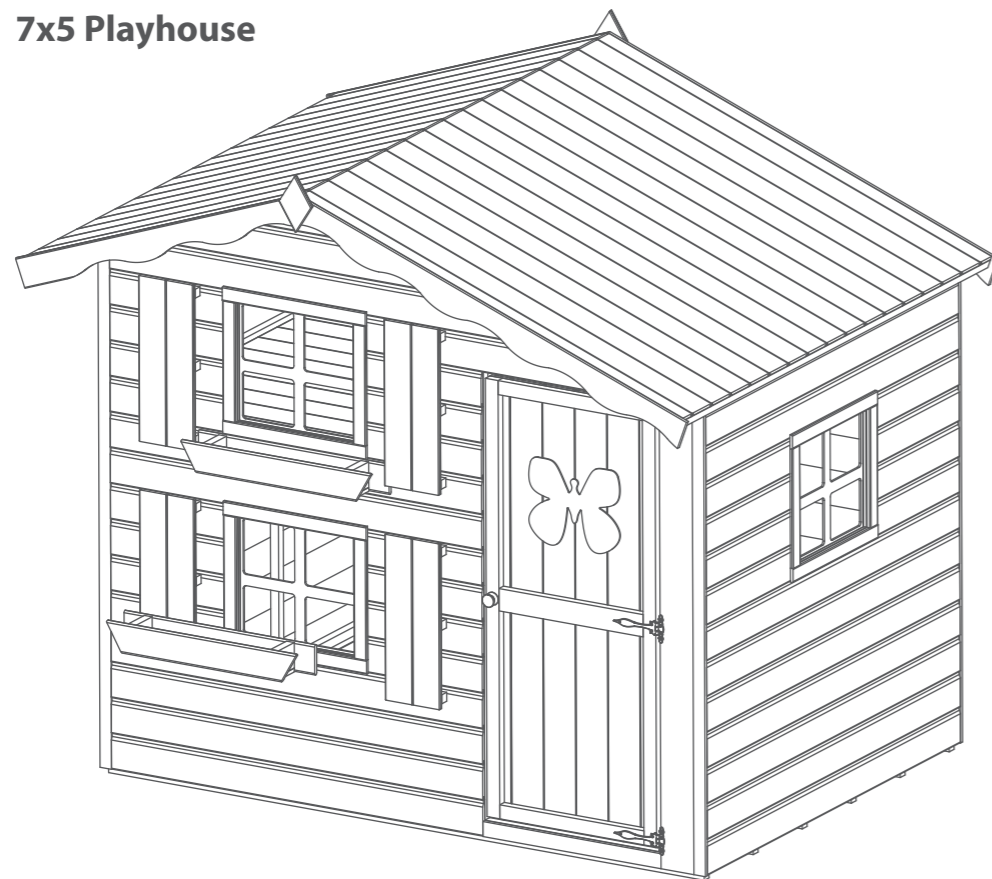

**7x6 Playhouse With Veranda**

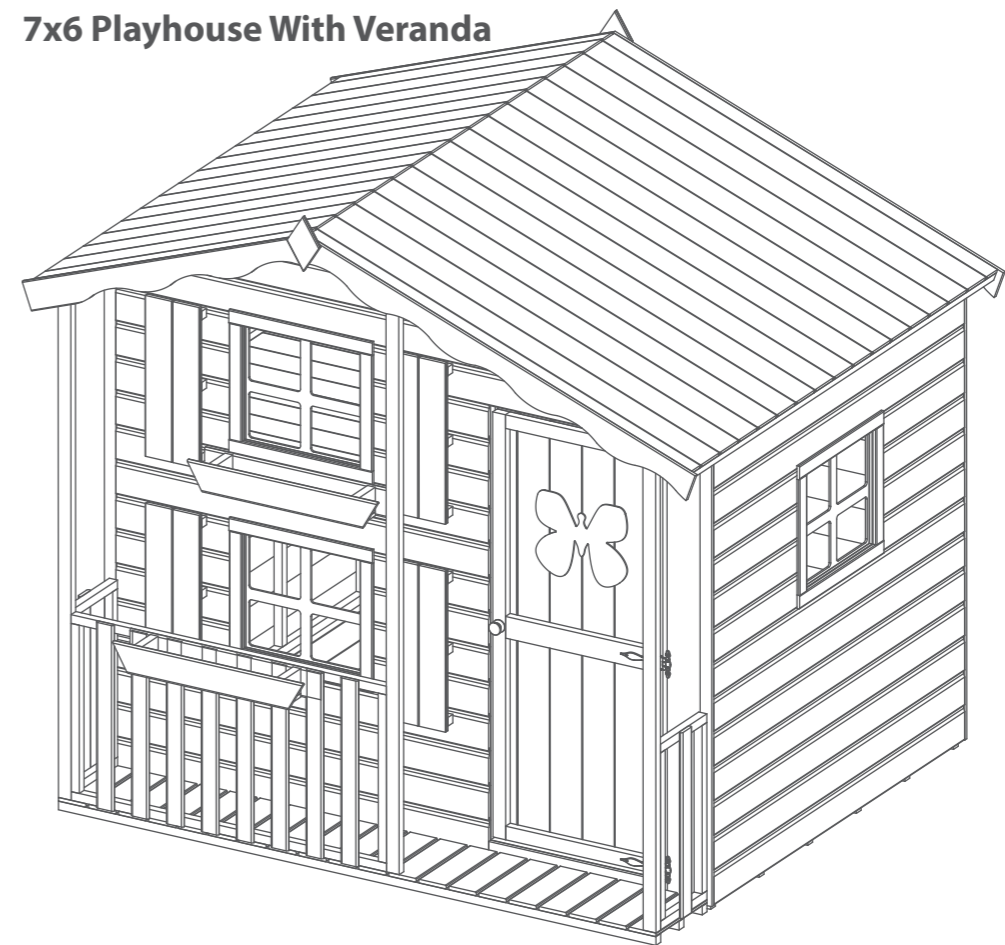



**Overall Dimensions:** Width = 2327mm  
Depth = 1824mm  
Height = 2042mm

**Base Dimensions:** Width = 2066mm  
Depth = 1456mm

**7x5 Contents:**  
02DTSHOA0705LFD3WBF-V1-PEFC

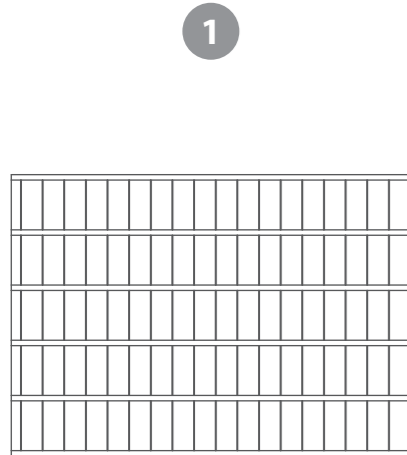
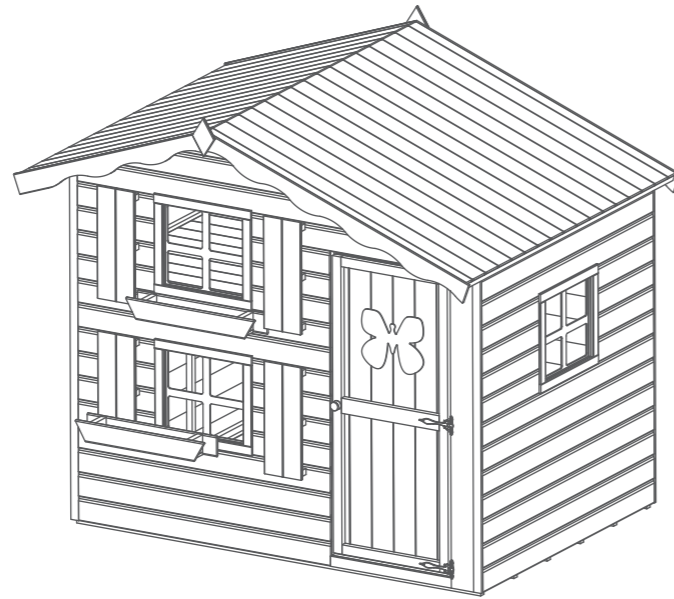

**Floor QTY 1**  
2066x 1456mm  
AI-S11MBF2066X1456-V1

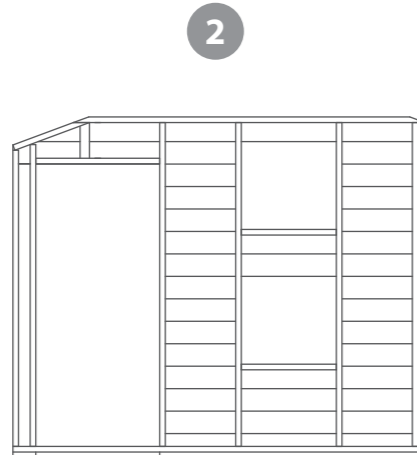

**Door Panel QTY 1**  
AI-02S112SWLFD2020X1691-V1



**Back Panel QTY 1**  
AI-S11SHPPBNK2020X1691-V1

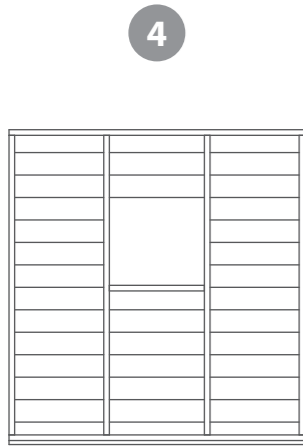

**Window Panel QTY 1**  
AI-02S111SW1475X1570-V1

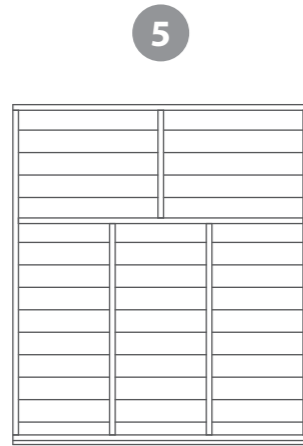

**Plain Panel QTY 1**  
AI-S11SHPPBNK1475X1695-V1

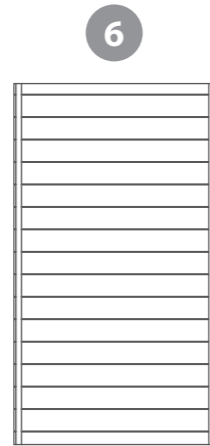

**Roof 1 QTY 1**  
1000 x 1800mm  
AI-S11MBOHAR1000X1800-V1

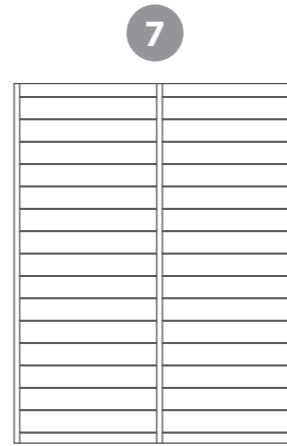

**Roof 2 QTY 1**  
1410 x 1800mm  
AI-S11MBOHAR1410X1800-V1

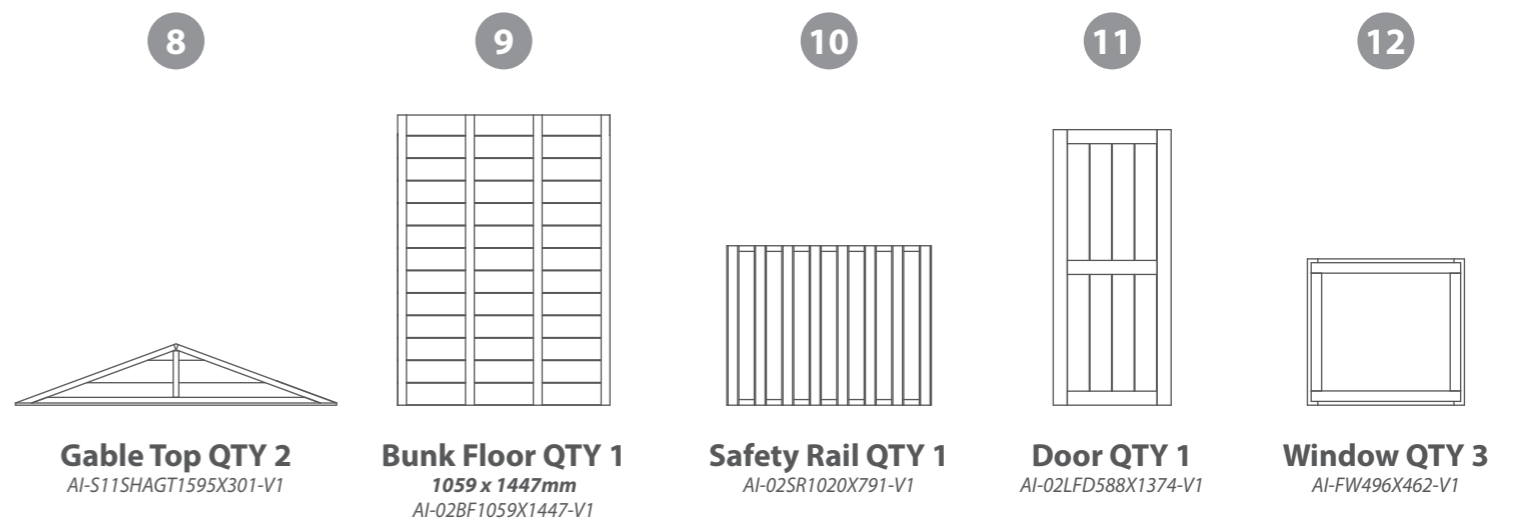

**Gable Top QTY 2**  
AI-S11SHAGT1595X301-V1

**Bunk Floor QTY 1**  
1059 x 1447mm  
AI-02BF1059X1447-V1

**Safety Rail QTY 1**  
AI-02SR1020X791-V1

**Door QTY 1**  
AI-02LFD588X1374-V1

**Window QTY 3**  
AI-FW496X462-V1

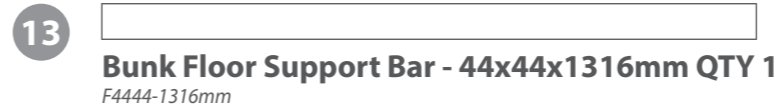

**Bunk Floor Support Bar - 44x44x1316mm QTY 1**  
F4444-1316mm

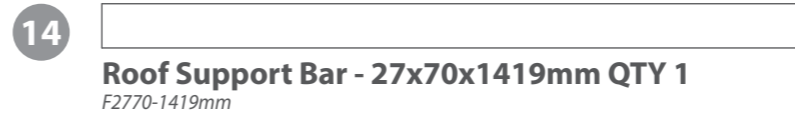

**Roof Support Bar - 27x70x1419mm QTY 1**  
F2770-1419mm

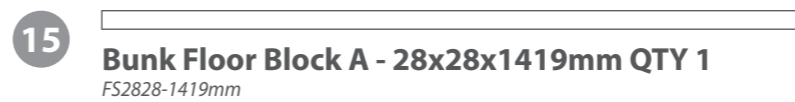

**Bunk Floor Block A - 28x28x1419mm QTY 1**  
FS2828-1419mm



**Bunk Floor Block B - 28x28x351mm QTY 2**  
FS2828-351mm



**Bunk Floor Block C - 28x28x72mm QTY 3**  
FS2828-72mm



**Gable Block A - 28x28x630mm QTY 2**  
FS2828-630mm

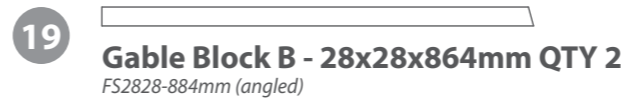

**Gable Block B - 28x28x864mm QTY 2**  
FS2828-864mm (angled)

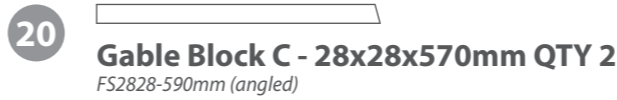

**Gable Block C - 28x28x570mm QTY 2**  
FS2828-570mm (angled)



**Gable Cover Trim A - 12x28x630mm QTY 2**  
S1228-630mm

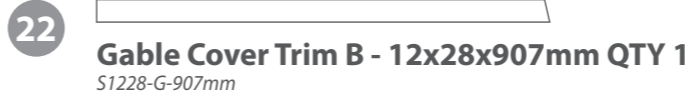

**Gable Cover Trim B - 12x28x907mm QTY 1**  
S1228-G-907mm



**Cover Trim A - 12x40x1566mm QTY 2**  
S1240-1566mm

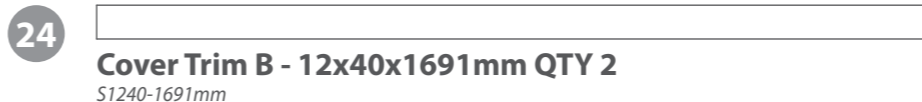

**Cover Trim B - 12x40x1691mm QTY 2**  
S1240-1691mm

DO NOT ALLOW YOUR CHILD TO PLAY WITH ANY COMPONENT PARTS PRIOR TO ASSEMBLY.



**25 Fascia - 12x95x1435mm QTY 2**  
FAS1295-G-1435mm



**26 Fascia - 12x95x1041mm QTY 2**  
FAS1295-G-1041mm



**27 Ladder Left - 27x95x1365mm QTY 1**  
PRO2795-1365mm-LEFT



**28 Ladder Right - 27x95x1365mm QTY 1**  
PRO2795-1365mm-RIGHT

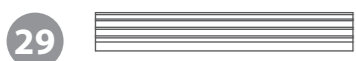

**29 Ladder Step - 27x58x390mm QTY 3**  
PRO2758-390mm

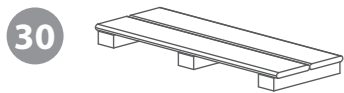

**30 Window Shutters QTY 4**  
AI-02WS190X520-V1

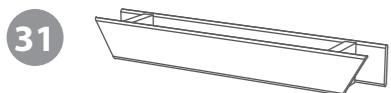

**31 Window Box QTY 2**  
AI-02WB661X95-V1



**32 Finial QTY 2**  
SHED DIAMOND FINIAL



**33 Door Stop QTY 2**  
PLY TRIANGLE



**34 Wooden Door Handle QTY 1**  
PI-04-0024

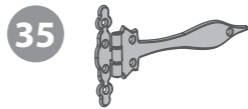

**35 Antique Hinge QTY 3**  
PI-07-0113

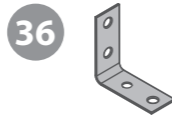

**36 Corner Brace QTY 2**  
PI-07-0012

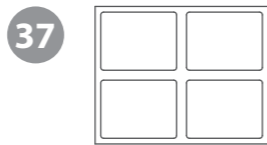

**37 Window Frame Cross QTY 3**  
PI-04-0013



**38 Butterfly QTY 1**  
PI-04-0015

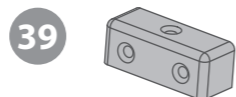

**39 Window Block QTY 6**  
PI-07-0011



**40 Felt**



**41 Door Spacer Strip QTY 4**  
SR1260-100mm

**Overall Dimensions:**  
Width = 2327mm  
Depth = 1824mm  
Height = 2042mm

**Base Dimensions:**  
Width = 2066mm  
Depth = 1777mm

**7x6 Playhouse With Veranda**

02DTSHOA0705LFD3WBF-V1-PEFC  
02DTOAVP0701-V1-PEFC

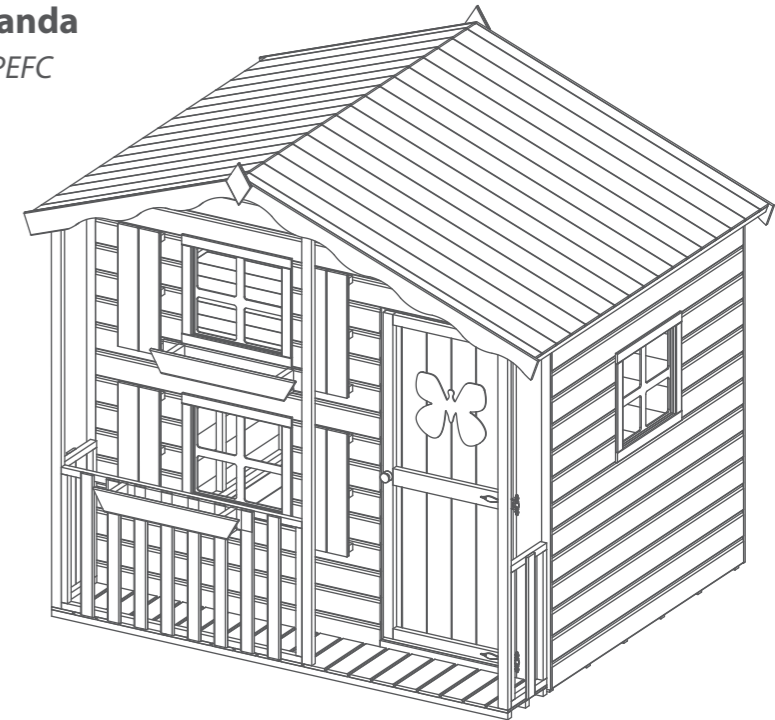

**7x1 Veranda Pack Contents:**  
(02DTOAVP0701-V1-PEFC)

42

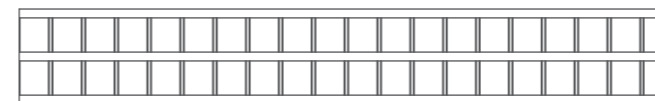

**Veranda Floor QTY 1**  
AI-S11STVF2066X300-V1

43

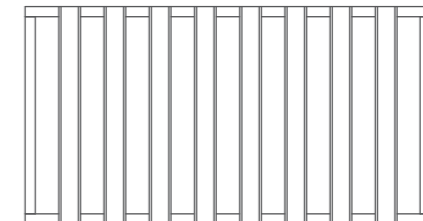

**Front Rail QTY 1**  
AI-02SR1090X600-V1

44

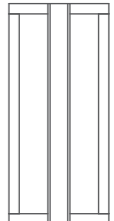

**Side Rail QTY 2**  
AI-02SR273X600-V1

45



**Support Rail A - 27x44x1891mm QTY 1**  
F2744-G-1911mm (angled)

46



**Support Rail B - 27x44x1693mm QTY 1**  
F2744-G-1713mm (angled)

47



**Support Rail C - 27x44x1568mm QTY 1**  
F2744-G-1588mm (angled)

**Nail Bag**

- 60mm Screw x 19
- 30mm Black Screw x 21
- 50mm Screw x 64
- 20mm Screw x 26
- 40mm Screw x 38
- 10mm Screw x 4
- 30mm Screw x 91
- Felt Tacks x 90

**Nail Bag**

- 60mm Screw x 2
- 50mm Screw x 8
- 40mm Screw x 19

DO NOT ALLOW YOUR CHILD TO PLAY WITH ANY COMPONENT PARTS PRIOR TO ASSEMBLY.

### Pre Assembly

Before assembling remove the transportation blocks from the bottom of each panel.

Take care removing the blocks as to not damage the panels. Tap with a flat headed screwdriver and hammer.

Dispose of the blocks once removed.

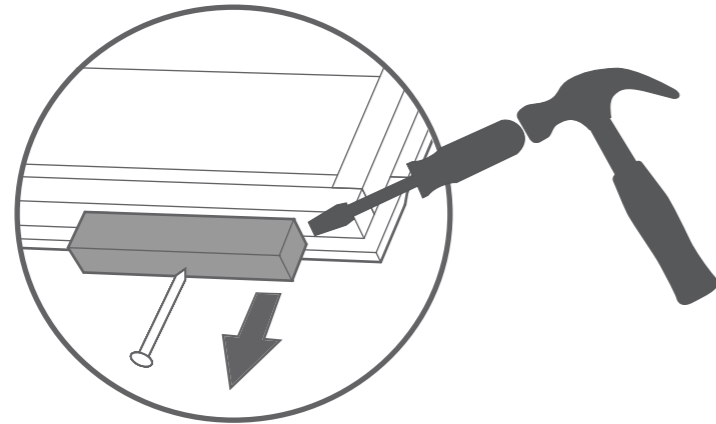

### Step 1

Parts needed - 2 & 4 & 12 & 39

Fix the Window Blocks (No. 39) to the Windows (No. 12) as shown with 1x30mm screw.

Place one Window (No. 12) into each window hole in the Door Panel (No.2), fix by screwing through the Window Blocks (No. 39) with 2x30mm screws per window block as shown.

Place one Window (No. 12) into the window hole in the Window Panel (No.4), fix by screwing through the Window Blocks (No. 39) with 2x30mm screws per window block as shown.

18x30mm screws.

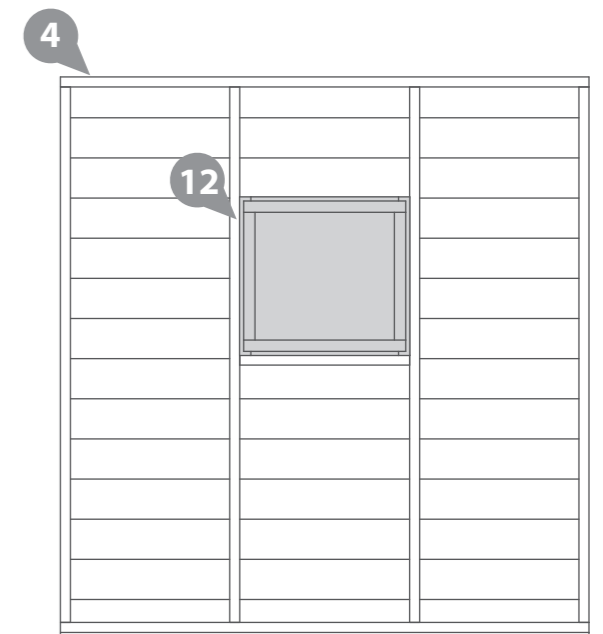
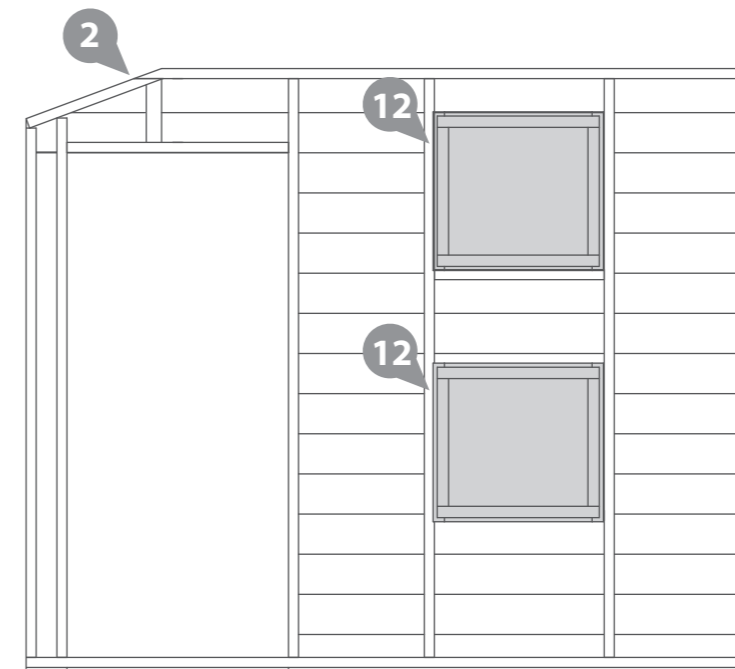
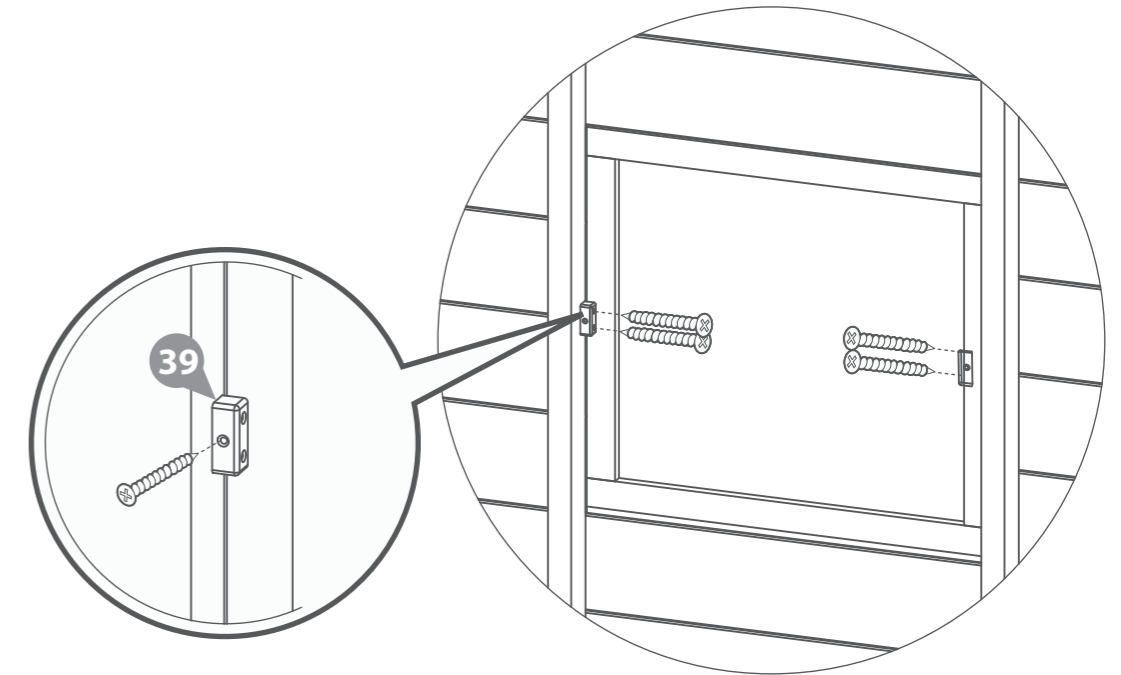

### Step 2

Parts needed - 2 & 3 & 8

Place the Door Panel (No.2) and Back Panel (No.3) on a flat level surface, with the framing facing up.

Locate the Gable Tops (No.8) on top of the Back Panel (No.3), and Door Panel (No.2), ensuring to interlock the bottom board of the gable with the top board of the panel, as shown in the diagram.

Secure the Gable Tops (No.8) by screwing through the framing using 5x50mm screws per gable, as shown in the illustration.

Ensure to stagger screws to avoid collision.

#### 10x50mm screws

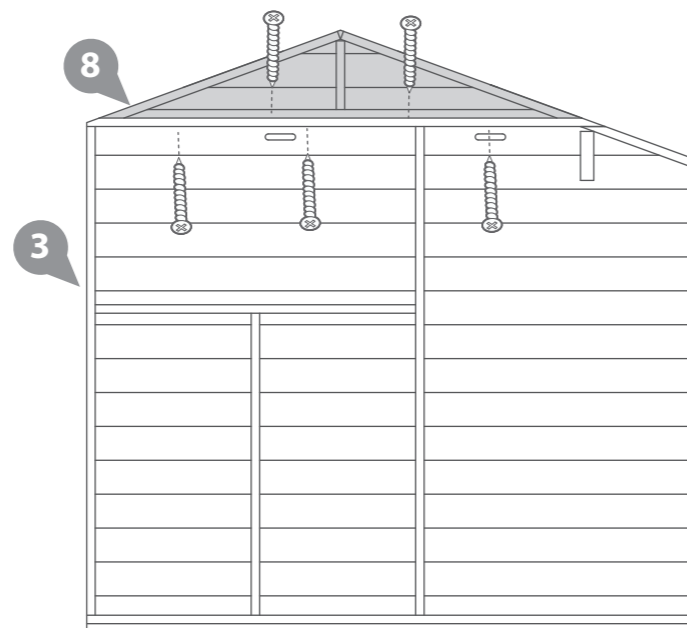
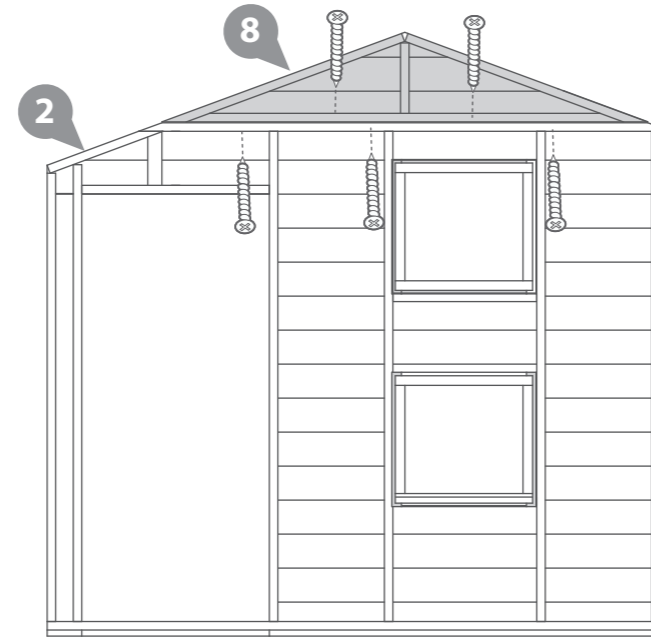
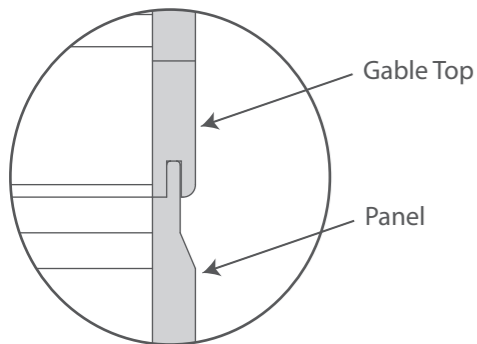

### Step 3

Parts needed - 18 & 19 & 20

Keep the assembled Door and Back Panels (No.2 & 3) on a flat level surface.

Position one Gable Block B (No.19) onto the top of the gable (No.8) on the shortest side, so that the angled end is flush to the edge of the Door Panel (No.2), as shown in the illustration.

Position one Gable Block C (No.20) onto the opposite side of the gable (No.8) so that the angled end is flush to the edge of the Door Panel (No.2), as shown in the illustration.

Position one Gable Block A (No.18) onto the remaining space on top of the gable (No.8) ensuring there is a 28mm gap between Block C (No.20) and block A (No.18), as shown in the illustration.

Secure in place by screwing through the blocks into the gable framing using 2x40mm screws per block.

Repeat these steps to fix the remaining Gable Blocks to the assembled Back panel and gable.

#### 12x40mm screws

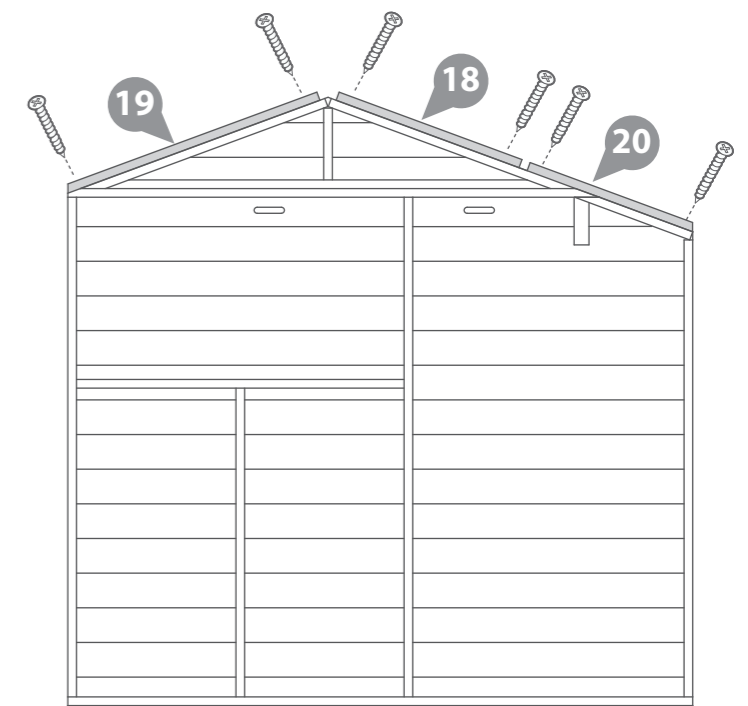
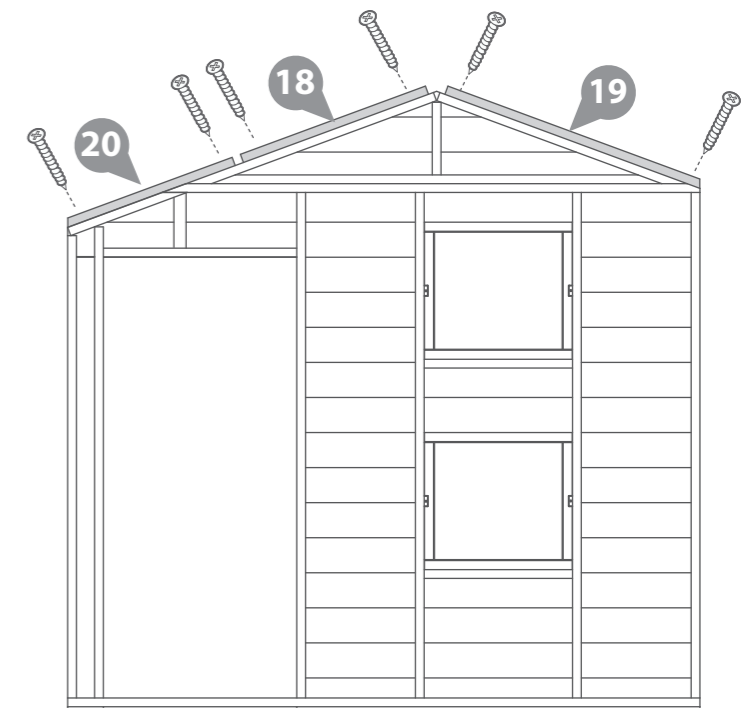
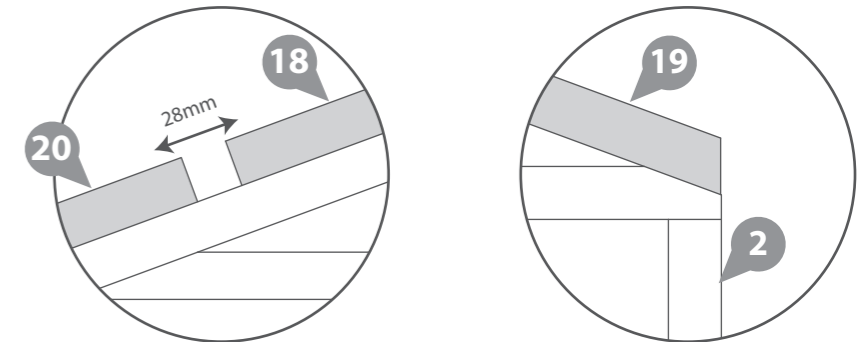



**Step 4**  
Parts needed - 2 & 11 & 35 & 41

**A** Flip the assembled Door Panel (No. 2 & 8) over so the boards are facing upwards and place the Door (No. 11) within the door aperture as shown. Position two Door Spacer Strips (No. 41) within the top gap between the door (No. 11) and the door panel (No. 2). Next position two Door Spacer Strips (No. 41) down the hinge side between the door (No. 11) and the door panel (No. 2).

The 12mm gap is to prevent serious injury should a child's fingers become trapped between the door and the door panel.

**B** Place the Hinges (No. 35) at the top, middle and bottom of the door (No. 11) and using 7x30mm black screws per hinge, fix the hinge to the door and the door panel.

21x30mm black screws

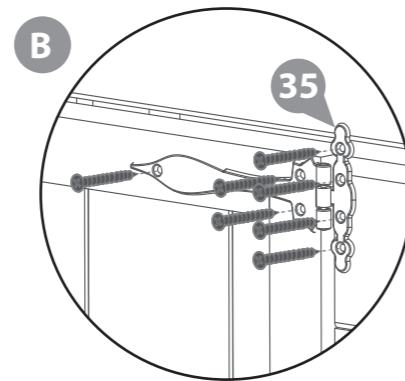
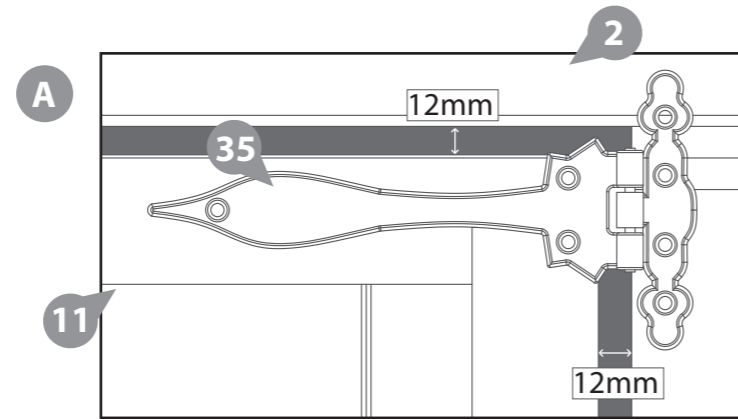
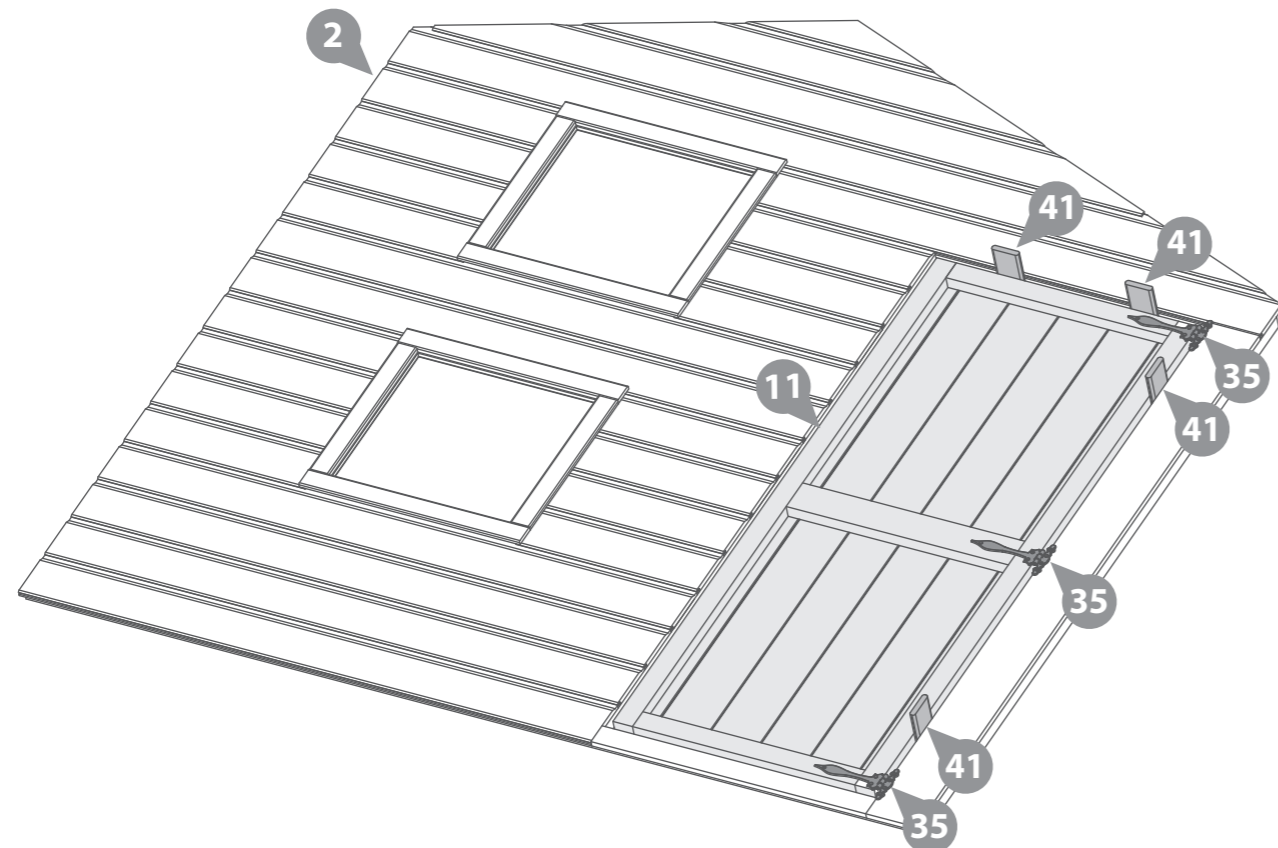
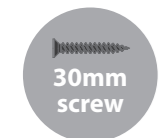

**Step 5**  
Parts needed - 1

Place the Floor (No.1) on a firm and level base, ensure the base has suitable drainage free from areas where standing water can collect. (see the front page for base requirements).

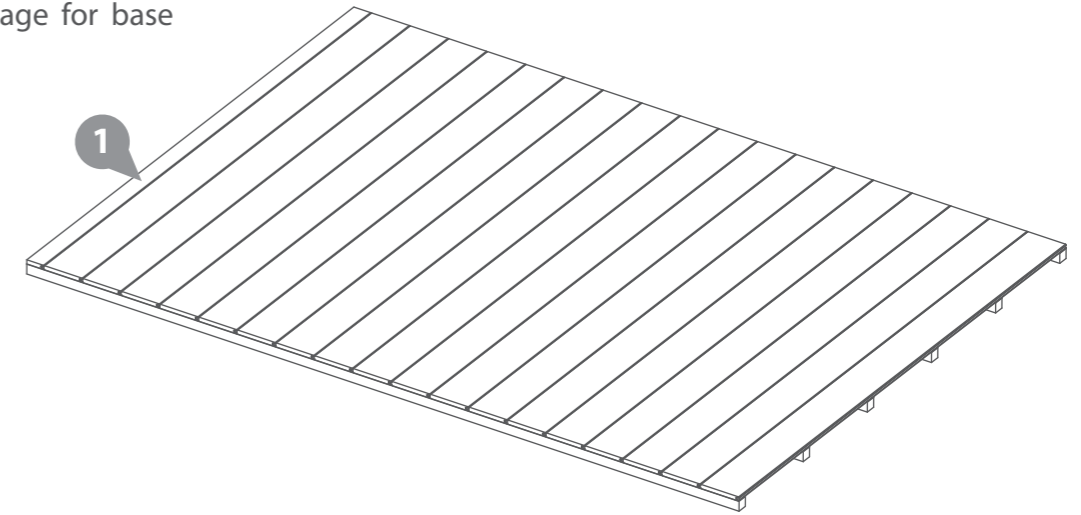

**Step 6**  
Parts needed - 3 & 5

Place the assembled Back Panel (No.3) and the Plain Panel (No.5) on top of the floor, ensuring the panels are positioned centrally on the floor, as shown in the illustration.

Fix together by screwing through the framing of the Back Panel (No.3) into the framing of the Plain Panel (No.5) using 3x50mm screws.

Do not secure the building to the Floor until the Roof is fitted.

3x50mm screws.

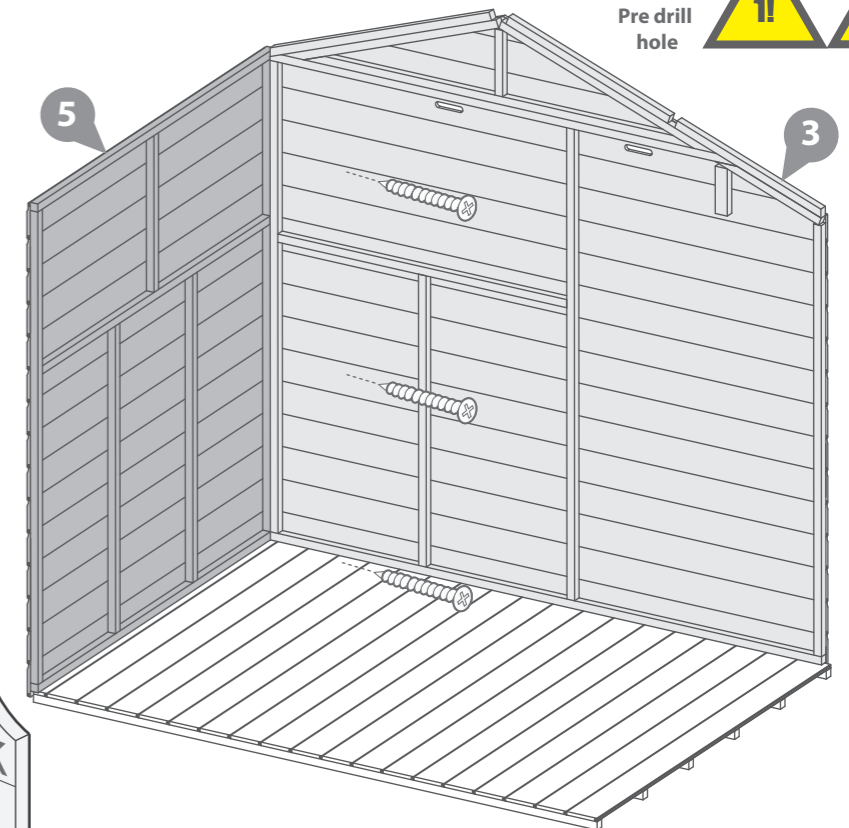
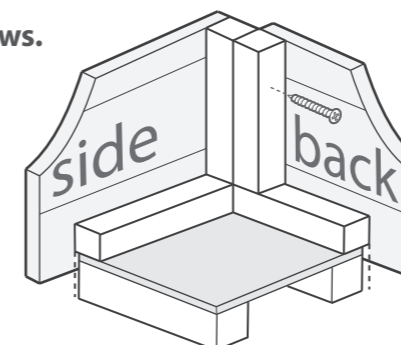

DO NOT ALLOW YOUR CHILD TO PLAY WITH ANY COMPONENT PARTS PRIOR TO ASSEMBLY.

**Step 7**  
Parts needed - 2 & 4

Place the assembled Door Panel (No.2) and the Window Panel (No.4) on top of the floor, ensuring the panels are positioned centrally on the floor, as shown in the illustration.

Fix together by screwing through the framing of the Door Panel (No.2) into the framing of the Plain Panel (No.5) and Window Panel (No.4) using 3x50mm screws.

**Do not secure the building to the floor until the Roof is fitted.**

9x50mm screws.

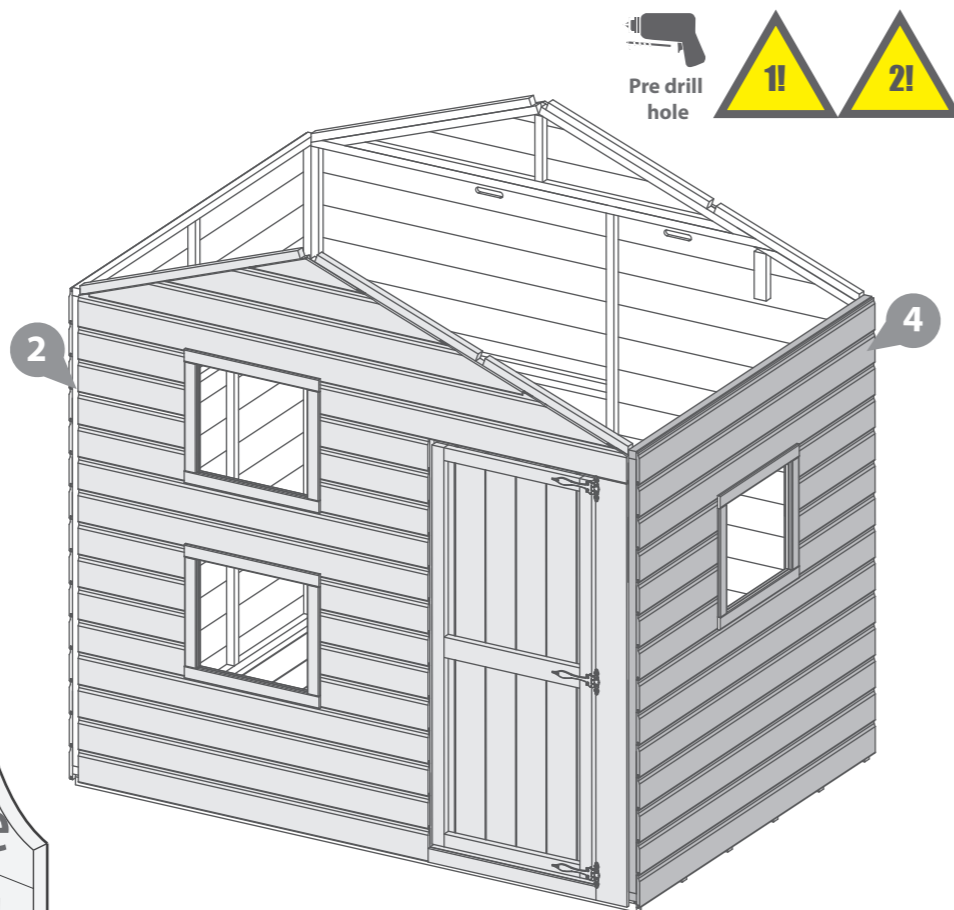
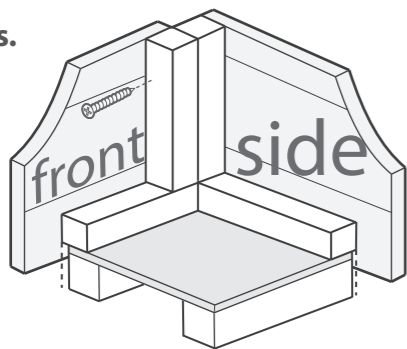

**Step 9**  
Parts needed - 13

Locate the Bunk Floor Support Bar (No.13) onto the Door Panel (No.2) at a height of 1010mm from the top of the floor to the underside of the Support Bar (No.13).

Secure in place by screwing through the Support Bar (No.13) into the upright panel framing using 4x60mm screws.

4x60mm screws.

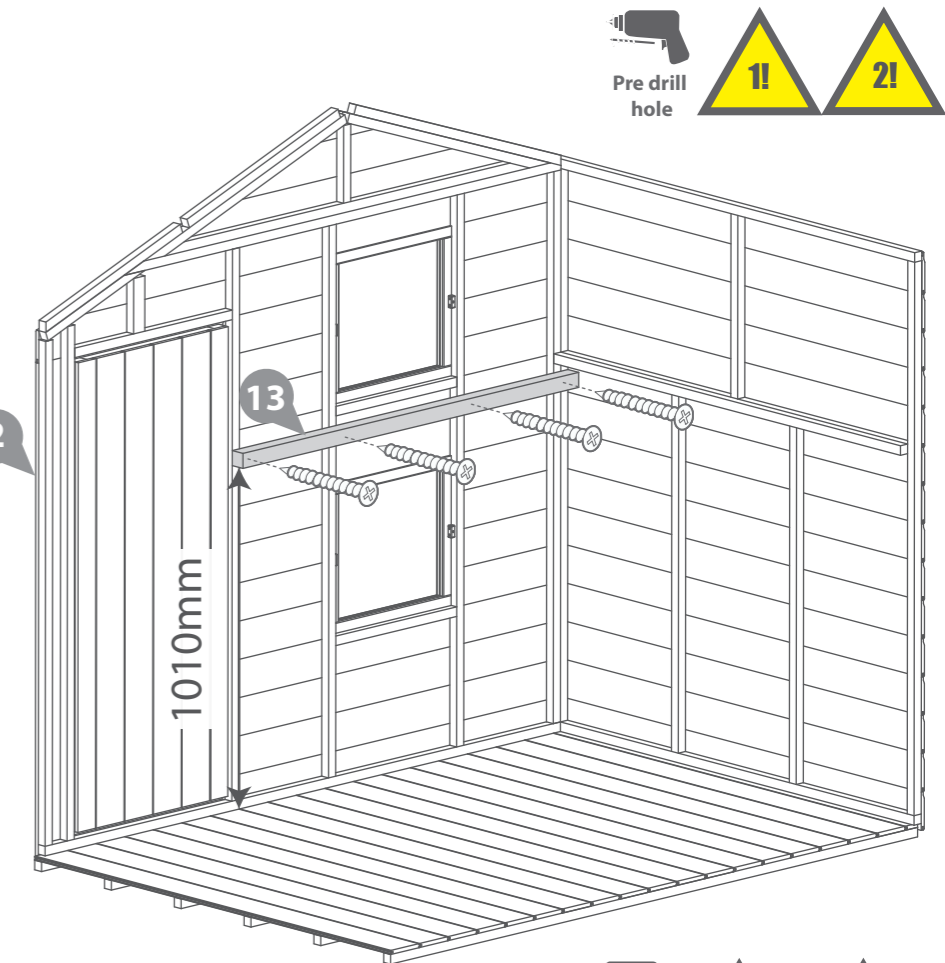

**Step 8**  
Parts needed - 15

Locate Bunk Floor Block A (No.15) flush to the horizontal framing on the Plain Panel (No.5).

Fix in place using 4x50mm screws.

4x50mm screws.

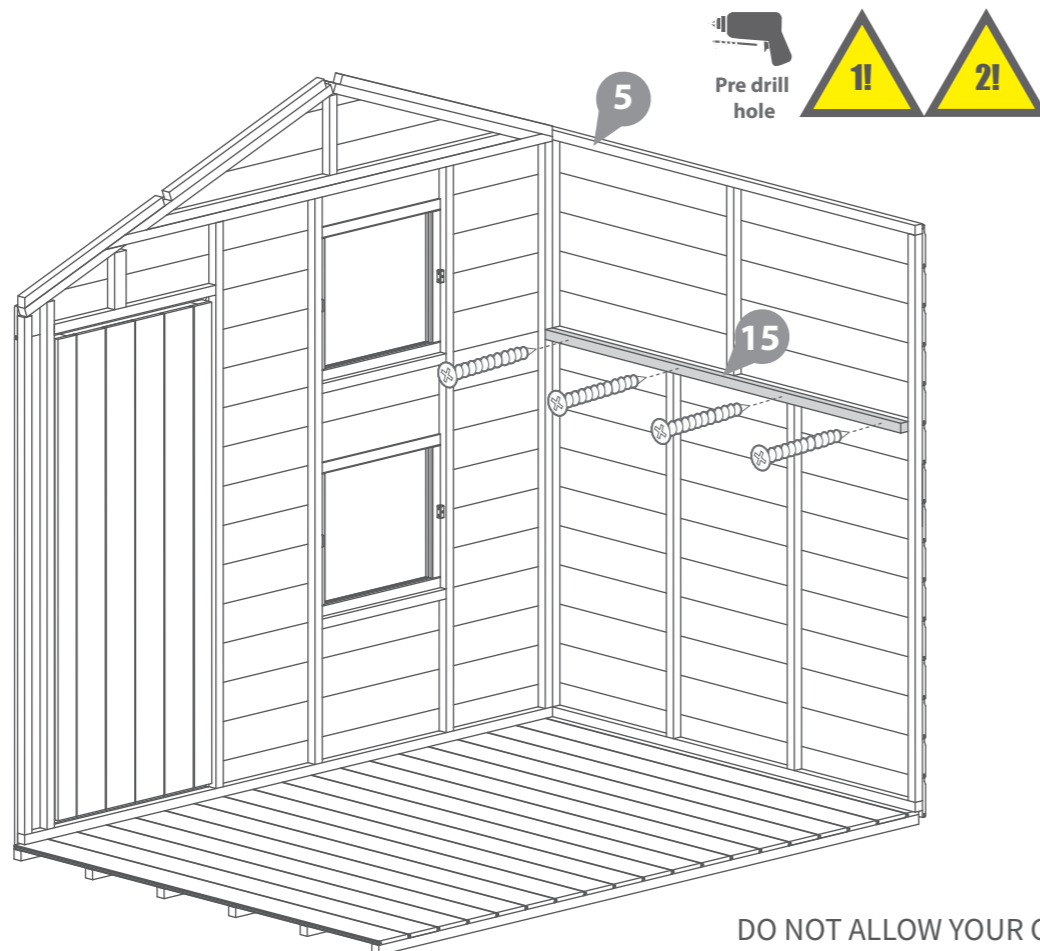

**Step 10**  
Parts needed - 16 & 17

**A** Locate one Bunk Floor Block C (No.17) flush to the Door panel framing. Ensure the top of block C is 28mm from the top of the support bar (No. 13). The longest side of the block should be against the panel framing.

Fix to the Door Panel using 1x40mm screw through the block into the framing.

**B** Locate Bunk Floor Block B (No. 16) on top of Block C as shown in the diagram.

Fix with 1x40mm screw through the panel framing into the left end of the block and 1x40mm screw down through block B (No.16) into block C (No. 17).

3x40mm screws

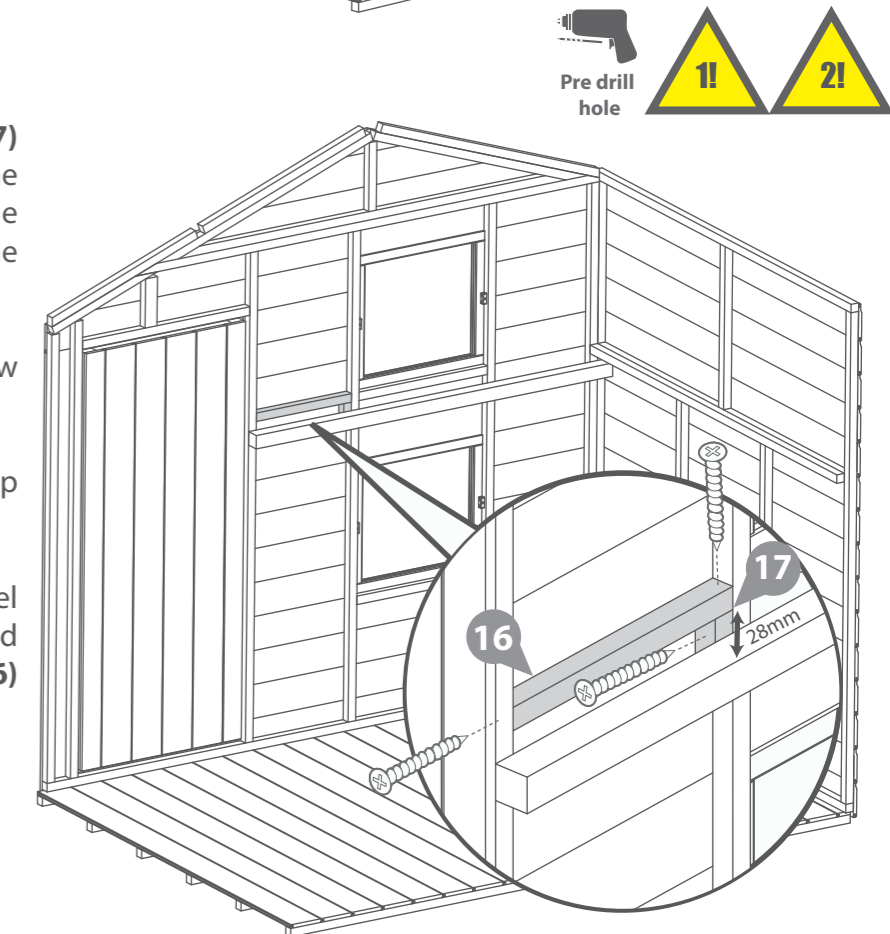

DO NOT ALLOW YOUR CHILD TO PLAY WITH ANY COMPONENT PARTS PRIOR TO ASSEMBLY.

**Step 11**  
Parts needed - 16 & 17

**A** Locate two Bunk Floor Block C's (No.17) flush to the Door panel framing. Ensure the top of block C is 28mm from the top of the support bar (No. 13). The longest side of the block should be against the panel framing.

Fix to the Door Panel using 1x40mm screw per block, through the block into the framing.

**B** Locate Bunk Floor Block B (No. 16) on top of the Block C's as shown in the diagram.

Fix with 1x40mm screw per end, down through block B (No.16) into block C (No.17).

4x40mm screws

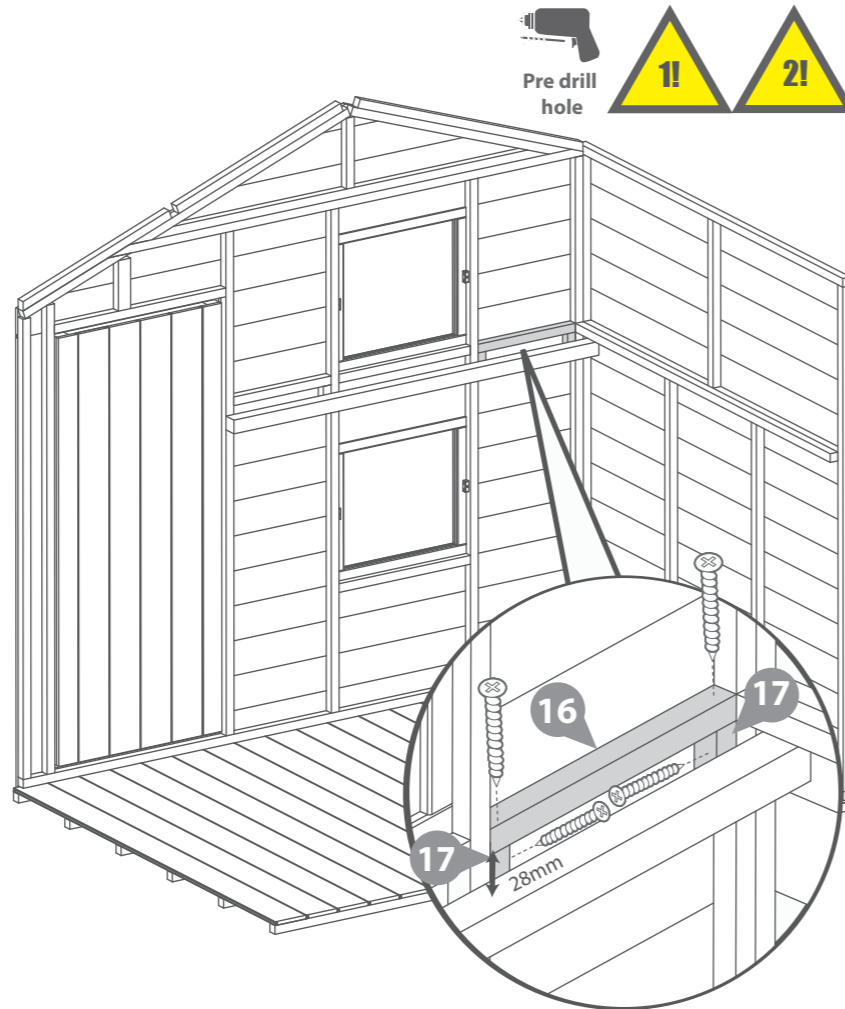

**Step 13**  
Parts needed - 9

Place the Bunk Floor (No. 9) on top of the Bunk Floor Support Bar (No.13) and horizontal framing of the Back Panel (No.3).

Ensure the Bunk Floor (No. 9) is flush with the framing on the plain panel and flush to the cladding on the back panel.

Fix into position by screwing up through the support bar (No.13) and Back Panel (No.3) framing into the Bunk floor bearers using 8x60mm screws as shown.

Secure in place by screwing through the Bunk Floor Bearers (No.9) into the Plain Panel framing (No.5) using 2x60mm screws.

**\*\*Please note: The bunk floor will not sit flush if the building is not sitting square. The building may need to be adjusted accordingly before fixing the bunk floor in place.**

10x60mm screws.

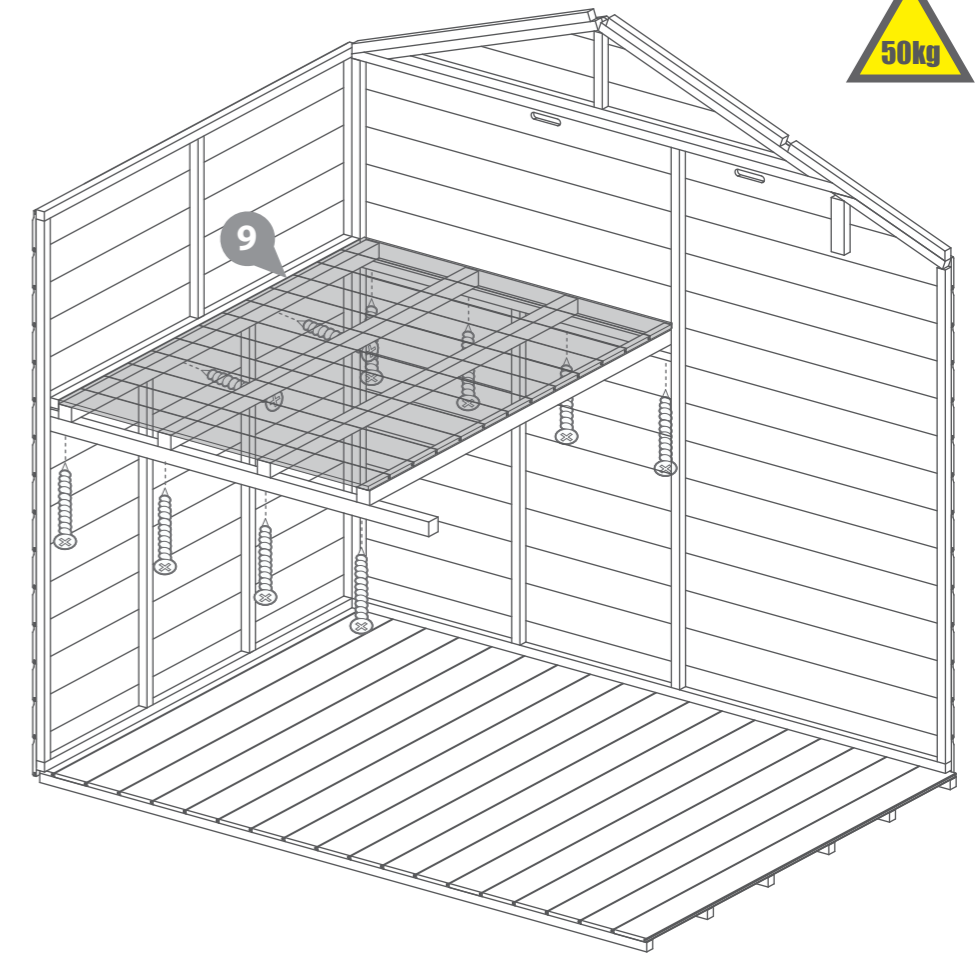
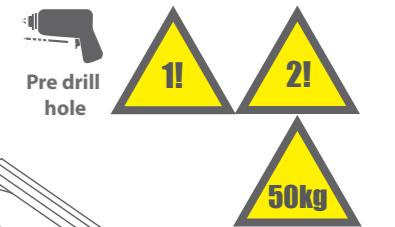
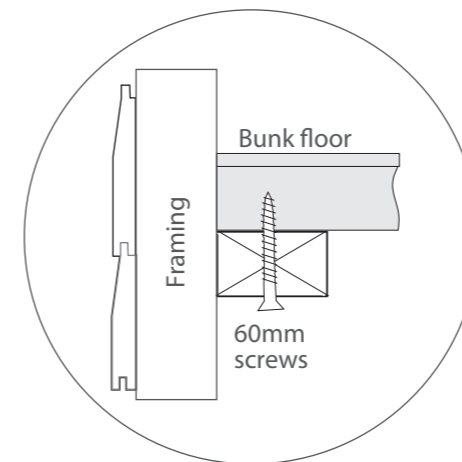

**Step 12**  
Parts needed - 27 & 28 & 29

To assemble the ladder, slot each Ladder Step (No.29) into the grooves of the Left (No. 27) and Right (No.28) Ladder Sides.

Fix with 4x50mm screws per step as shown.

12x50mm screws.

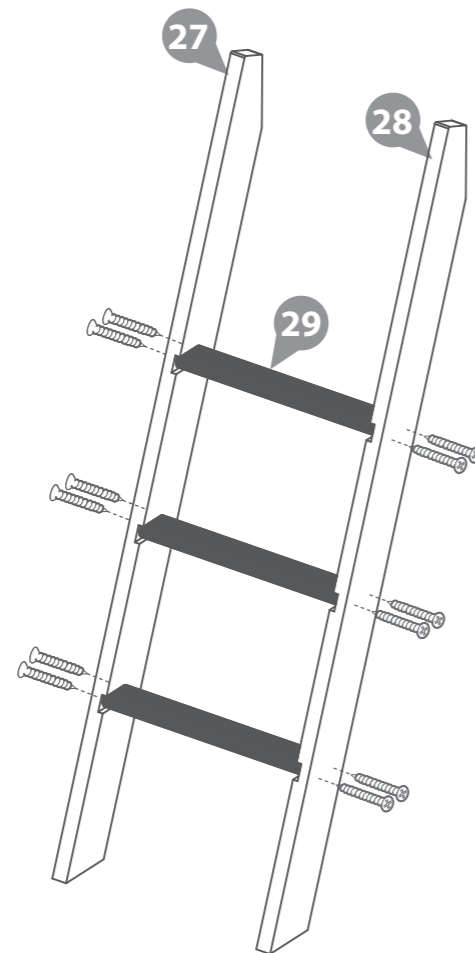

DO NOT ALLOW YOUR CHILD TO PLAY WITH ANY COMPONENT PARTS PRIOR TO ASSEMBLY.

**Step 14**  
Parts needed - 10

Locate the Safety Rail (No.10) on top of the bunk floor, ensure the safety rail is flush with the edge of the bunk, as shown in the illustration.

Fix in place using 4x60mm screws through the rail into the bunk floor.

Locate the assembled ladder flush to the safety rail and back panel framing.

Fix in place with 1x60mm screws, through the ladder into the Rail and 3x 40mm screws through the ladder into the Floor and Back Panel as shown in the diagram.

5x60mm screws  
3x40mm screws

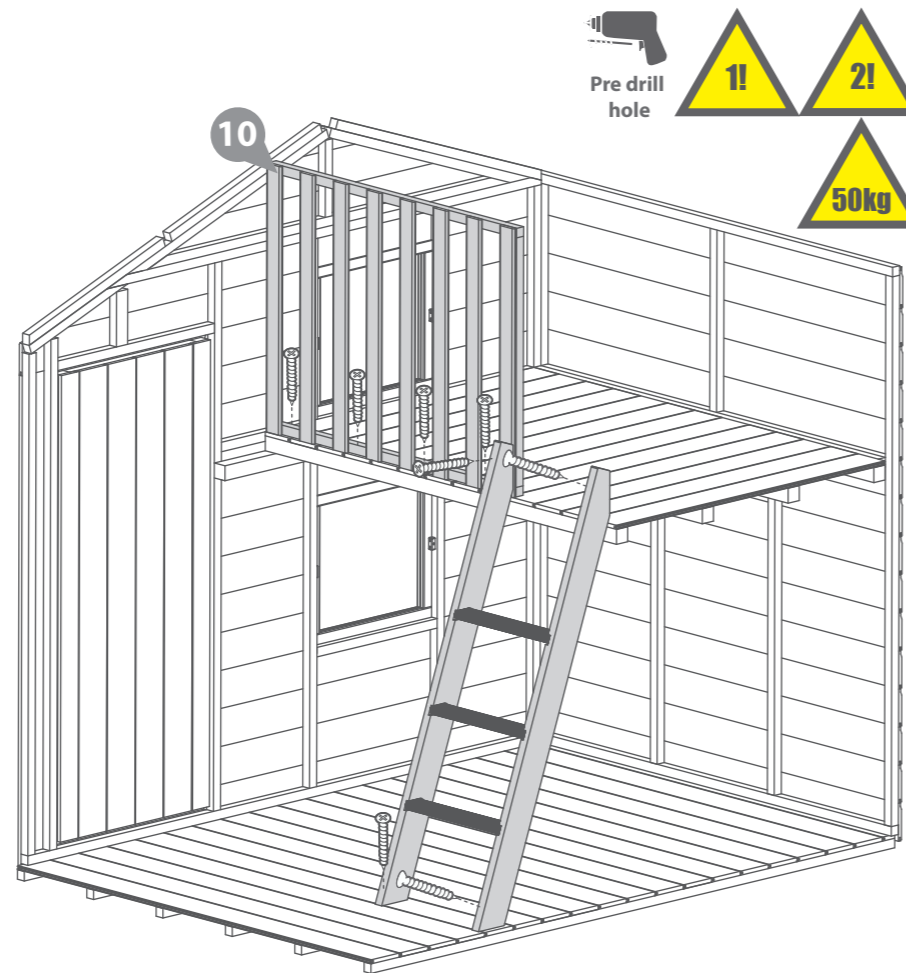

**Step 16**  
Parts needed - 6

Place Roof 1 (No.6) onto the shorter side of the building, ensuring the roof rests into the gaps of the gable framing and is flush to the back of the building.

Make sure the 10mm overhang on the roof is at the apex of the building.

Secure by screwing through the roof panel (No.6) into the panel below using 6x30mm screws. Ensure there is no more than 300mm between each screw.

**Do not secure the building to the Floor until the Roof is fitted.**

10x30mm screws

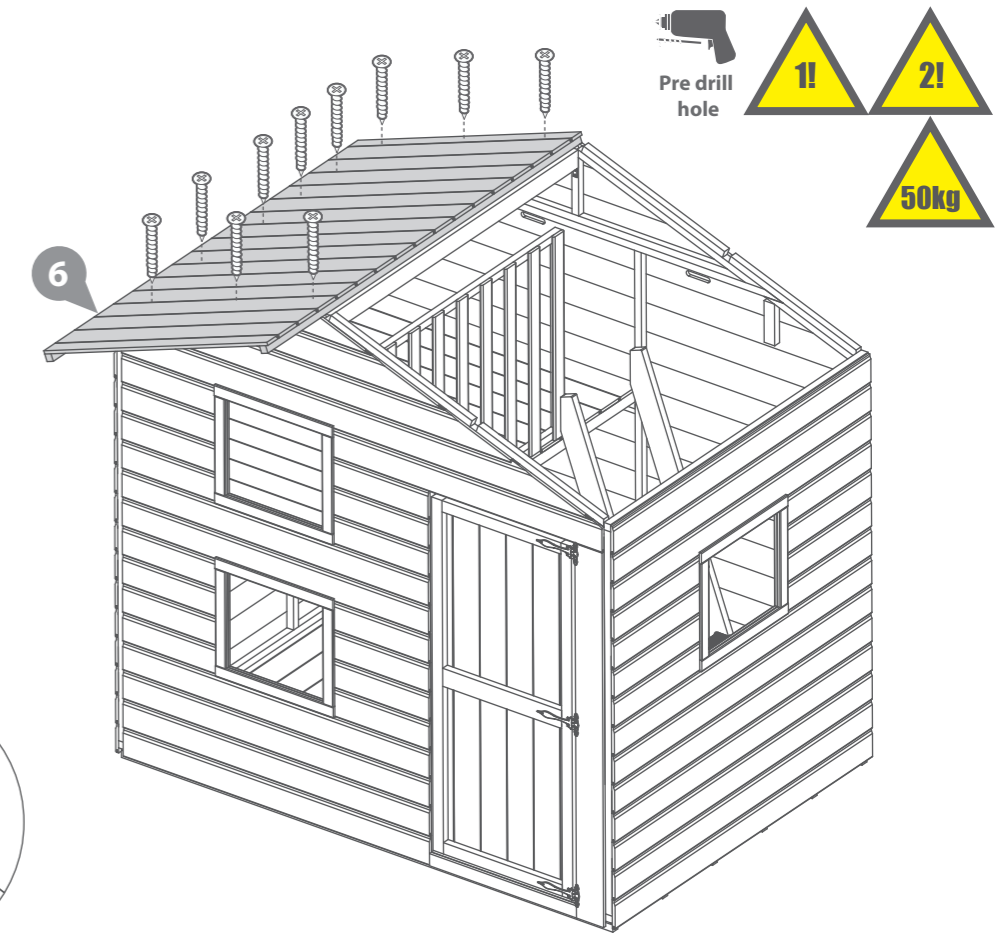
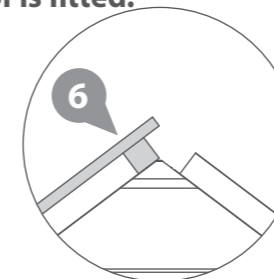

**Step 15**  
Parts needed - 14 & 36

Locate the Roof Support Bar (No. 14) in line with the central framing of the Gable Tops (No.8).

Fix in place with one Corner brace (No. 36) per end, using 4x30mm screws per brace.

8x30mm screws

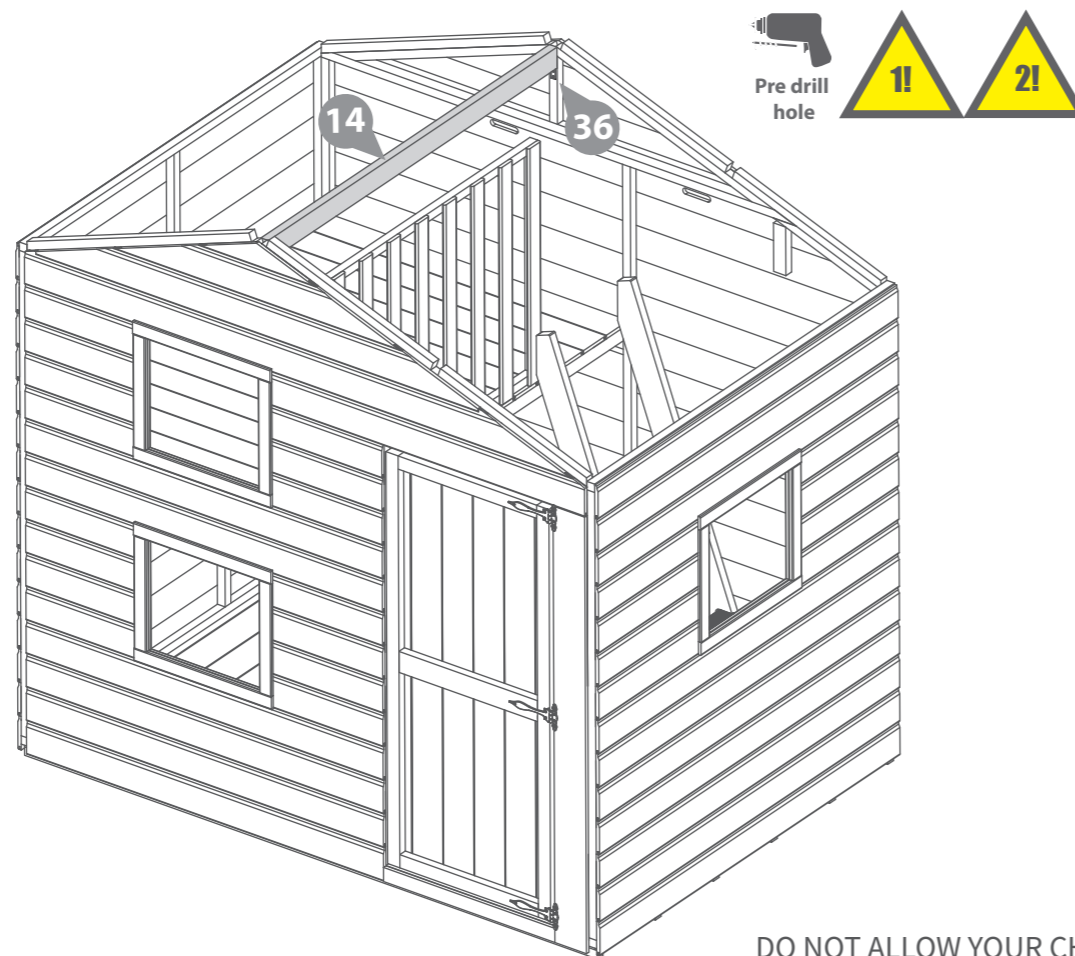
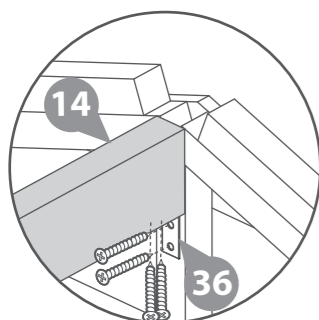

**Step 17**  
Parts needed - 7

Place Roof Panel 2 (No.7) onto the building, ensuring the roof rests into the gaps of the gable framing and is flush to the back of the building.

Make sure the 10mm overhang on the roof is at the apex of the building.

Secure by screwing through the roof panel (No.7) into the panel below using 8x30mm screws. Ensure there is no more than 300mm between each screw.

**Do not secure the building to the Floor until the Roof is fitted.**

11x30mm screws

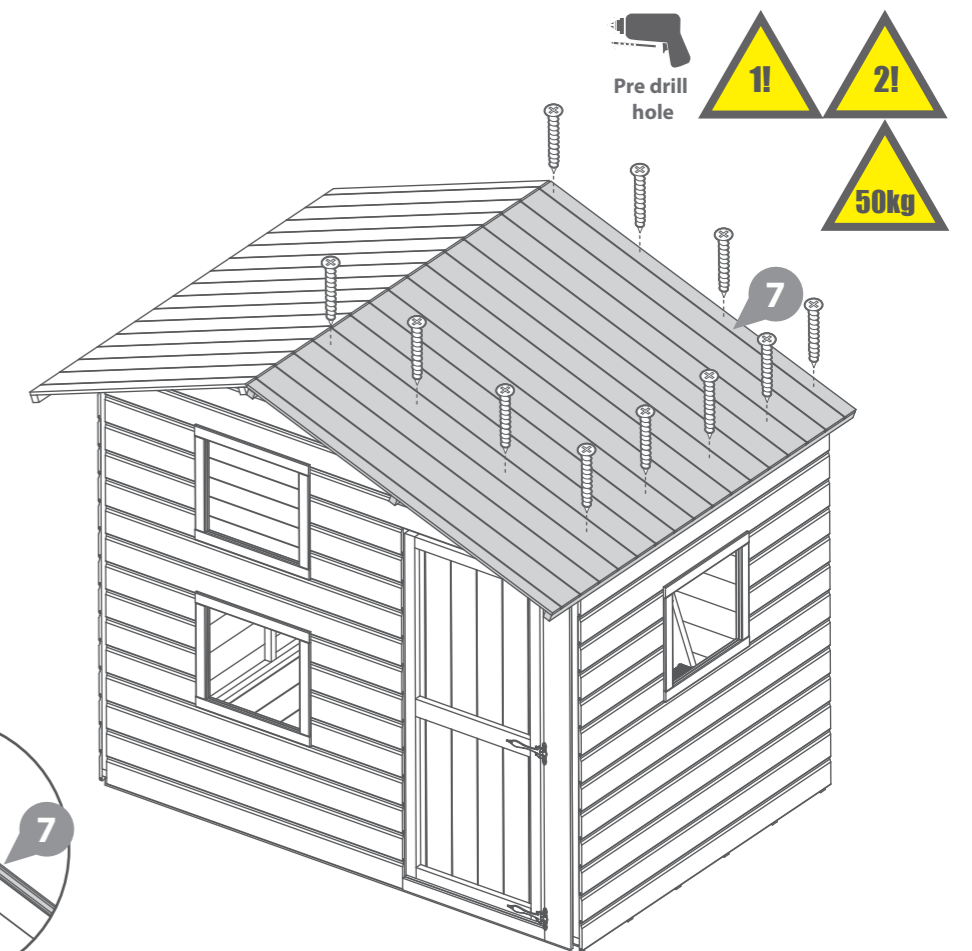
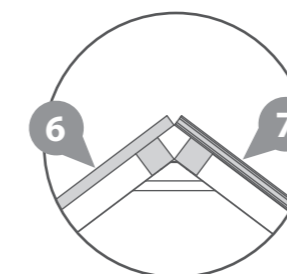
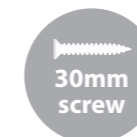

DO NOT ALLOW YOUR CHILD TO PLAY WITH ANY COMPONENT PARTS PRIOR TO ASSEMBLY.

**Step 18**

Once the roof is fitted and the building is square, secure the building to the Floor, using 50mm screws in alignment with the floor joists.

**22x50mm Screws**

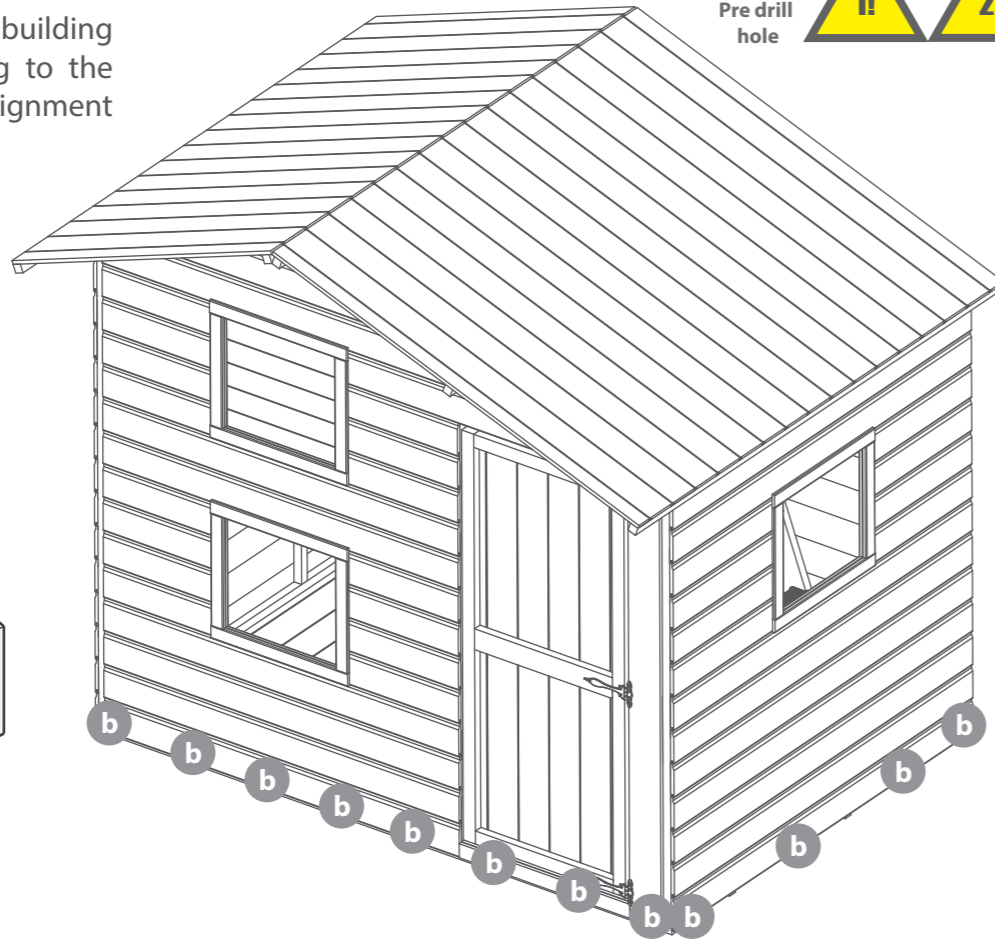
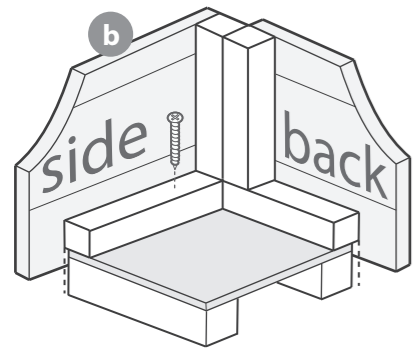

**Step 19**

**Parts needed - 21 & 22 & 23 & 24**

Fix Gable Cover Trim B (No. 22) to the Left hand side of the Front Gable Top (No.8) with 3x30mm screws per Trim.

Fix the Gable Cover Trim A's (No. 21) to the right hand side of the front Gable Top (No.8) with 3x30mm screws per trim.

Fix the Cover Trims A & B (No. 23 & 24) to the corners of the building with 3x30mm screws per trim.

The Trims (No. 22, 23 & 24) attached to the front corners of the gable top will need to be cut to fit the angle, as shown in the diagram.

**21x30mm screws.**

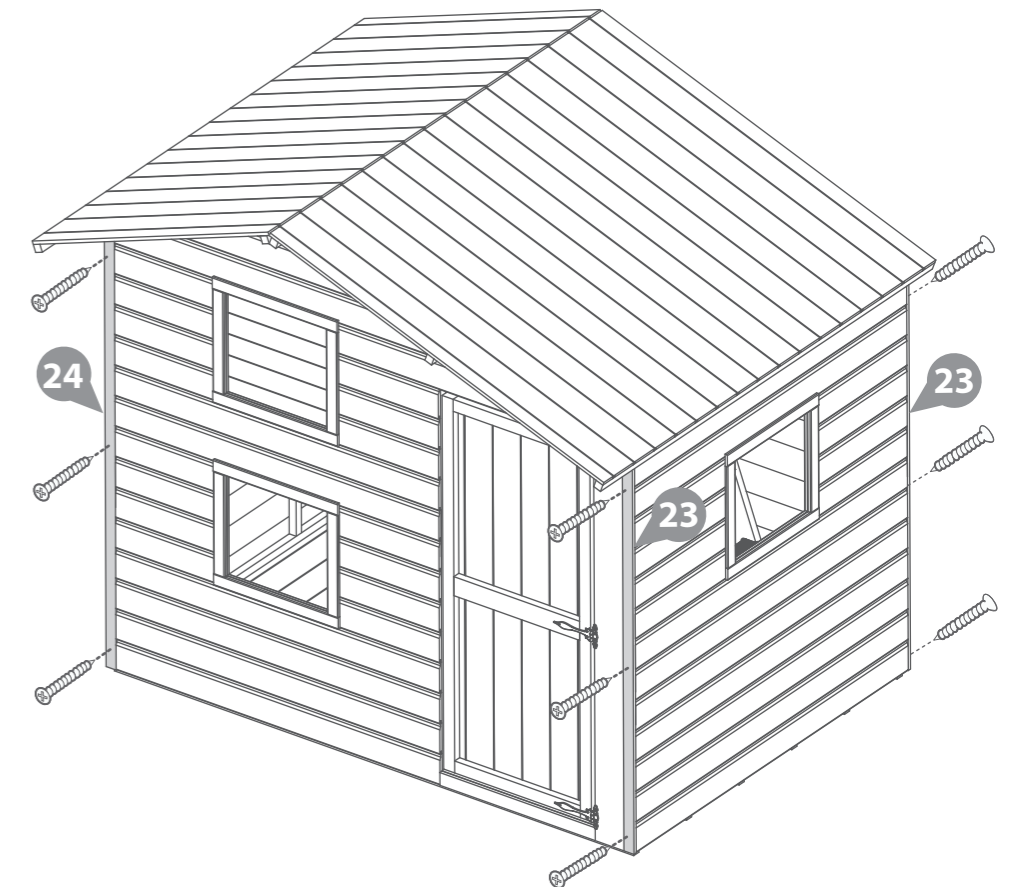
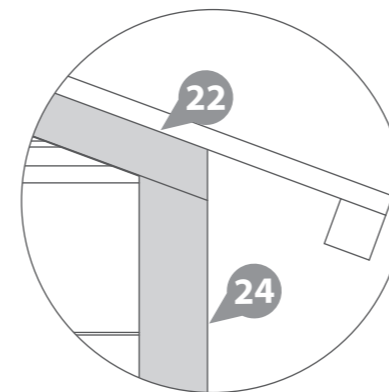

**Step 20**  
**Parts needed - 40**

Cut the felt (No. 40) into 3 sheets measuring:  
**1900mm (L) X 1000mm (W)**  
 and lay onto roof. Start at the bottom of the roof and work your way up so that rain pours over the top of the laps and not under them. Ensure there is a 50mm overhang around the sides.

Fix using felt tacks at 100mm intervals.

**90 Felt Tacks**

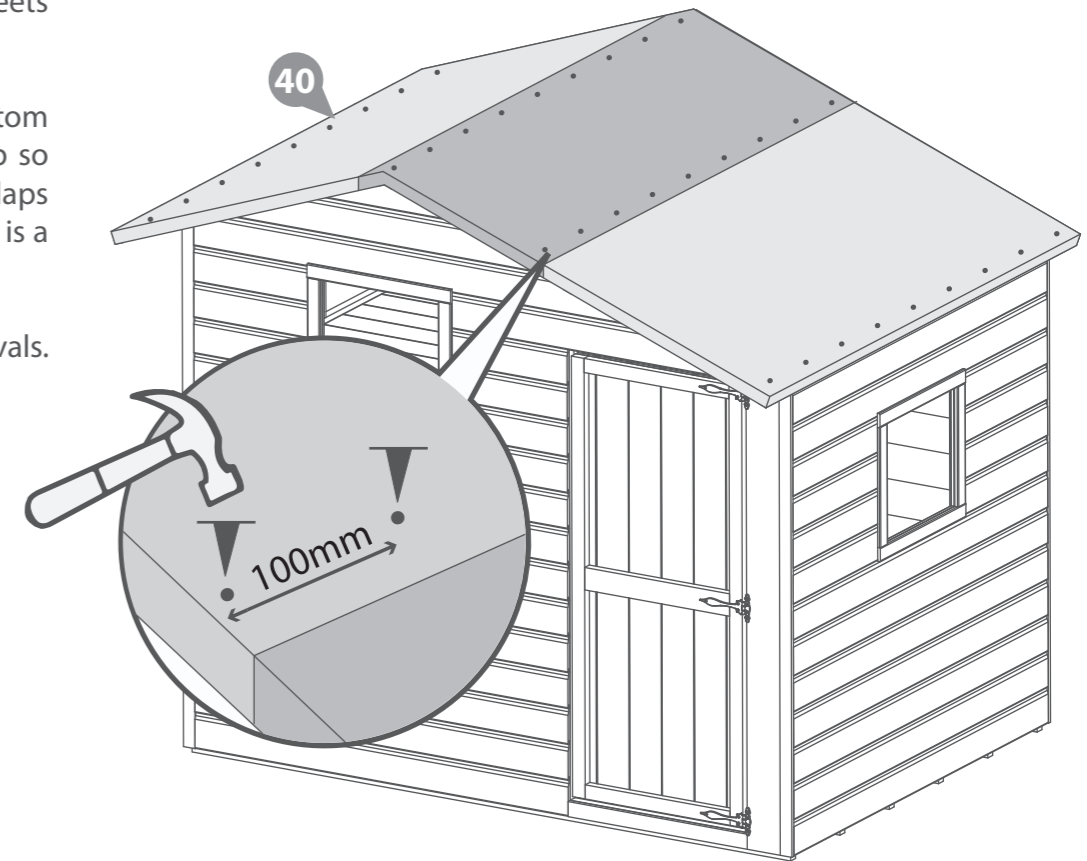

**\*\*If you have purchased a 7x1 Veranda add on Pack B, please skip and continue from step 20a on page 16\*\***

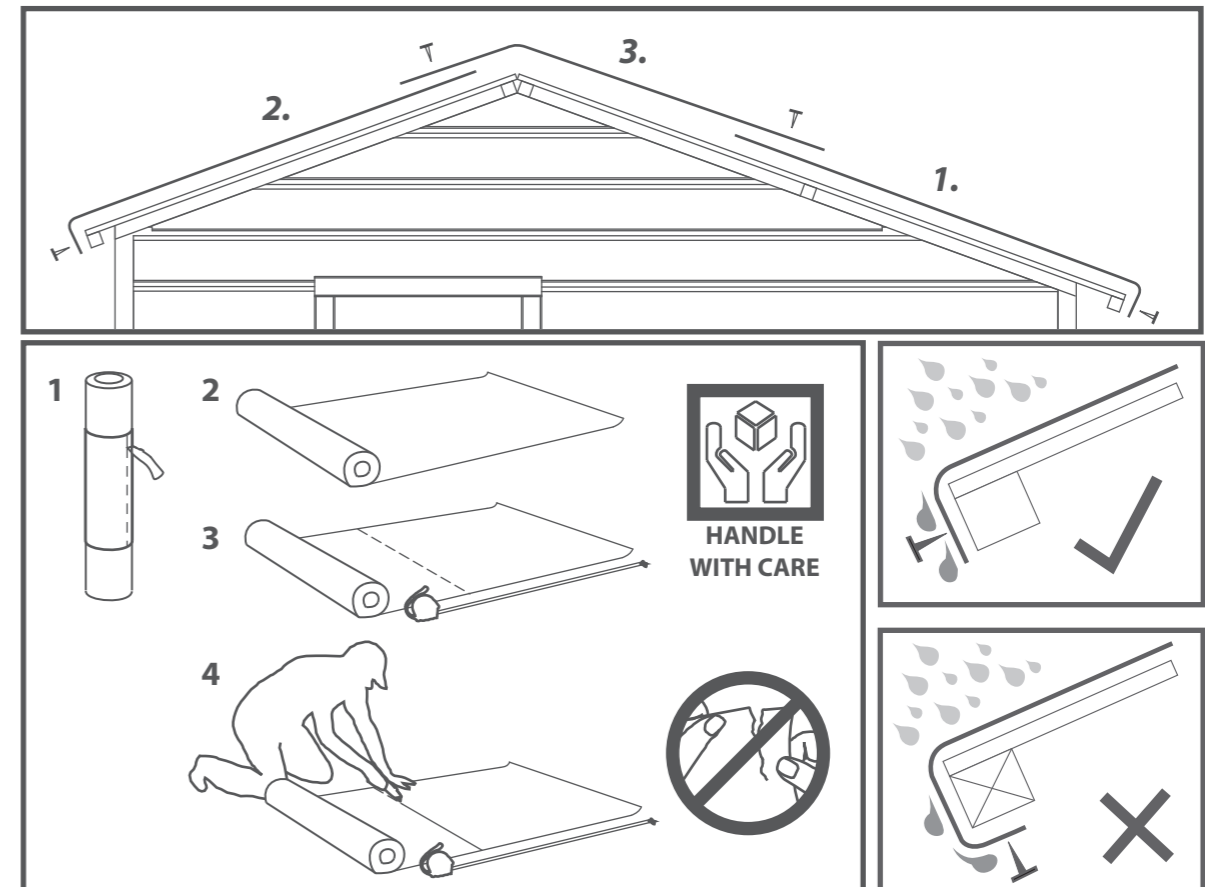

**Step 21**  
Parts needed - **25 & 26 & 32**

Fix the Fascias (**No. 25 & 26**) to the front and back of the building using 3x40mm screws per Fascia.

Fix the Finials (**No.32**) centrally over the Fascias using 2x40mm screws per finial.

Ensure to trap the felt between the Fascia and the building.

**16x40mm Screws**

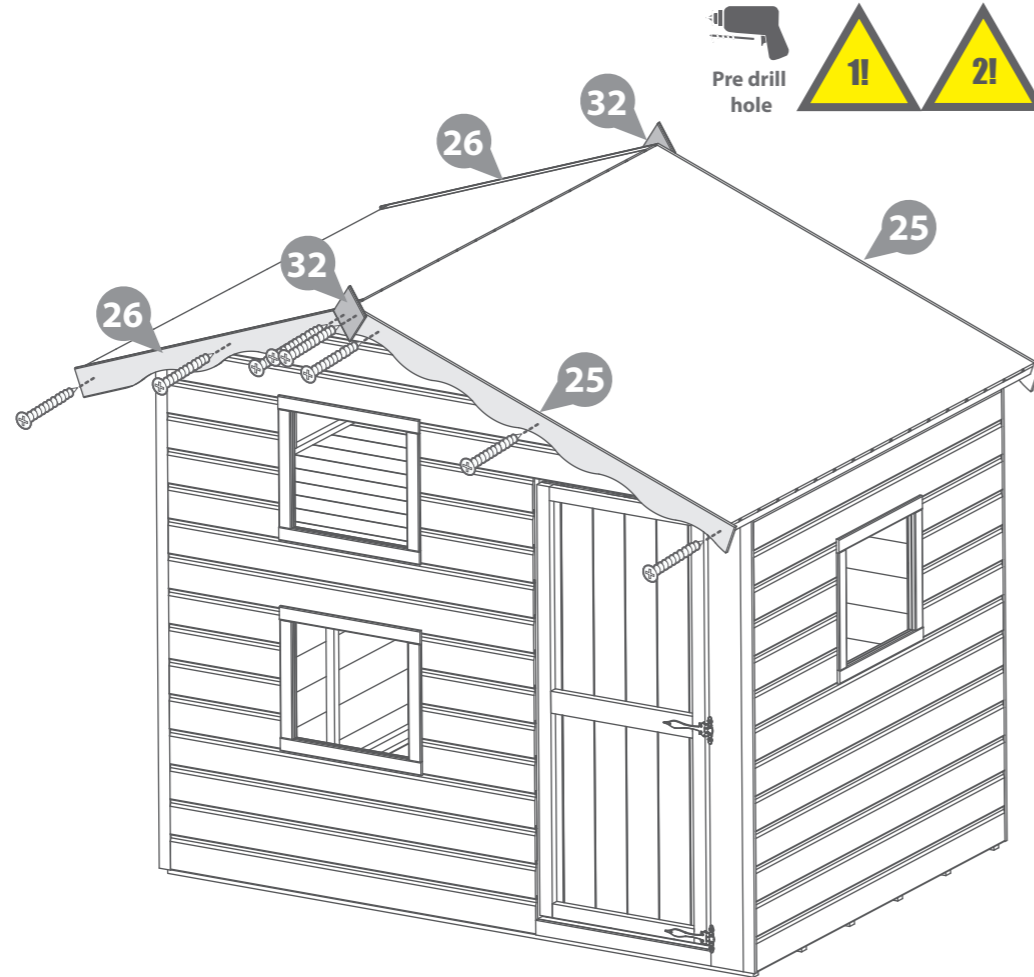

**Step 22**  
Parts needed - **30 & 31**

**A** Locate a Window Box (**No.31**) below each window on the Door Panel. Secure in place by screwing from inside the playhouse, through the cladding into the Box, using 4x20mm screws per box.

**B** Locate 2 Window Shutters (**No.30**) around the windows on the Door Panel. Secure in place by screwing from inside the playhouse, through the cladding into the Shutter framing, using 6x30mm screws per shutter.

**24x30mm screws.**  
**8x20mm screws.**



Every effort has been made to reduce sharp edges but it is recommended that any points are rounded.

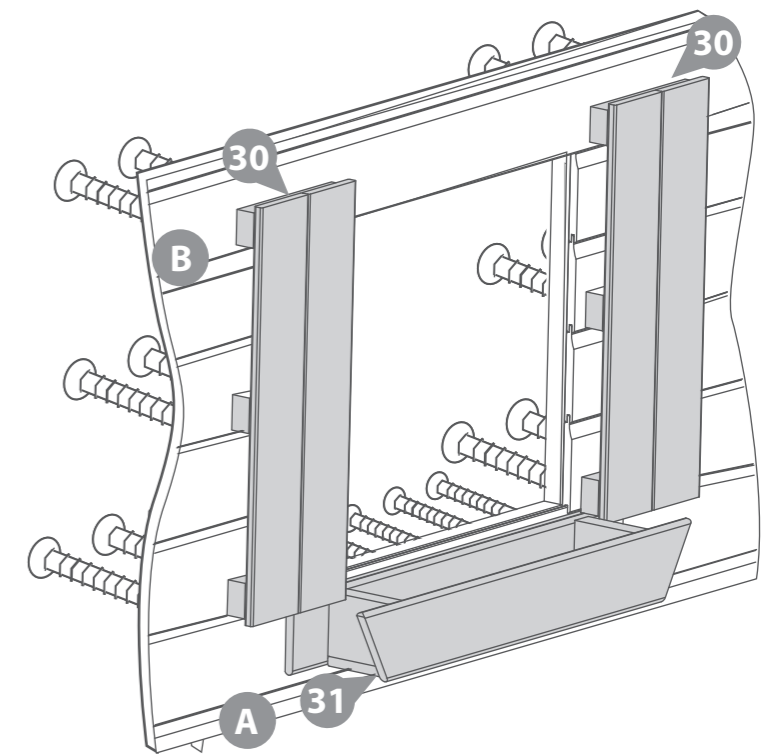
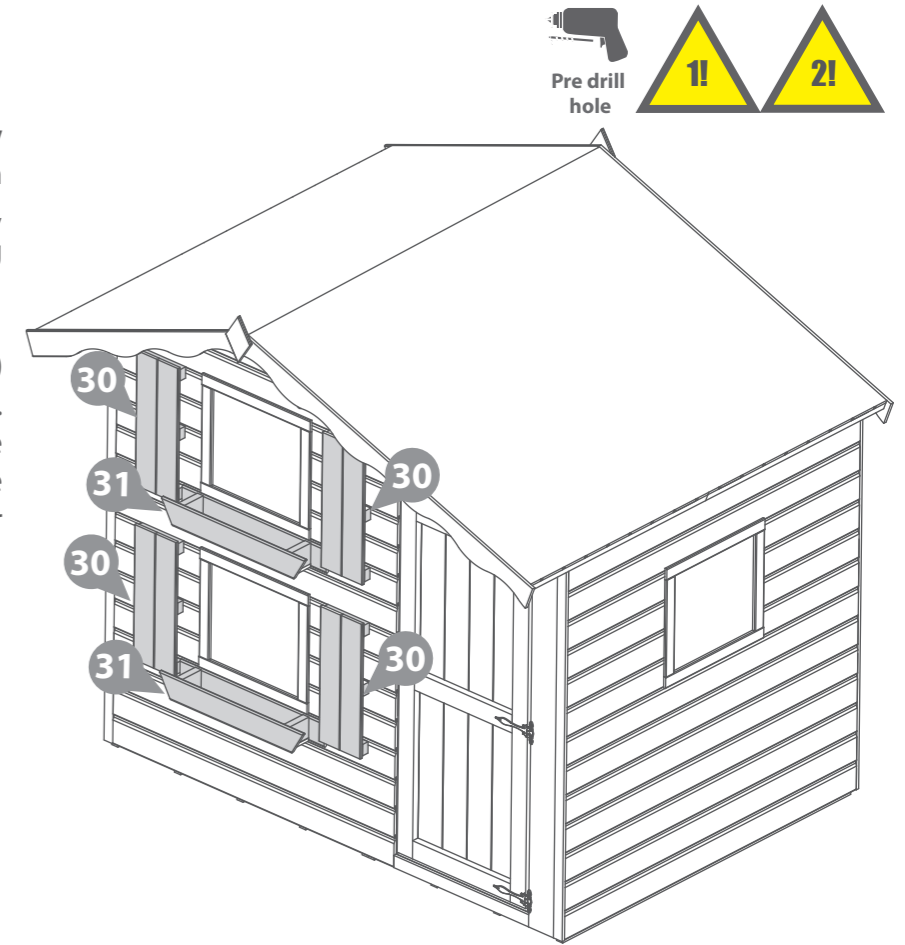

**Step 23**  
**Parts needed - 33 & 34 & 37 & 38**

**A** Place a Window Frame Cross (No. 37) against the inside of each window. Position the frame centrally to the window and fix using 4x20mm screws per frame.

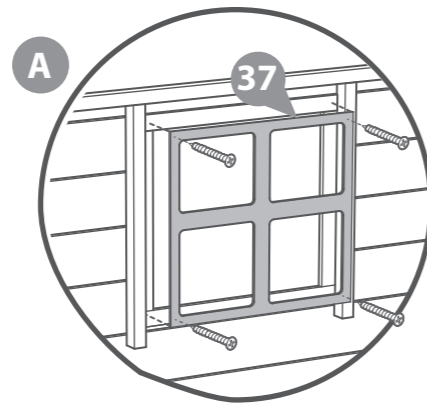

**B** Locate the Wooden Door Handle (No. 34) onto the outside of the door. Fix in place by hand, screwing through the door with the screw attached to the door handle.

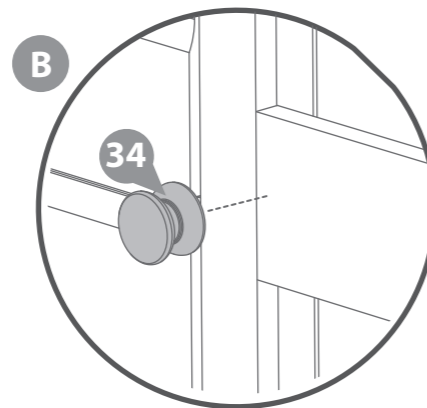

**C** Fix the Door Stop (No. 33) to the inside of the Door Panel at the top and bottom using 3x20mm screws as shown per door stop.

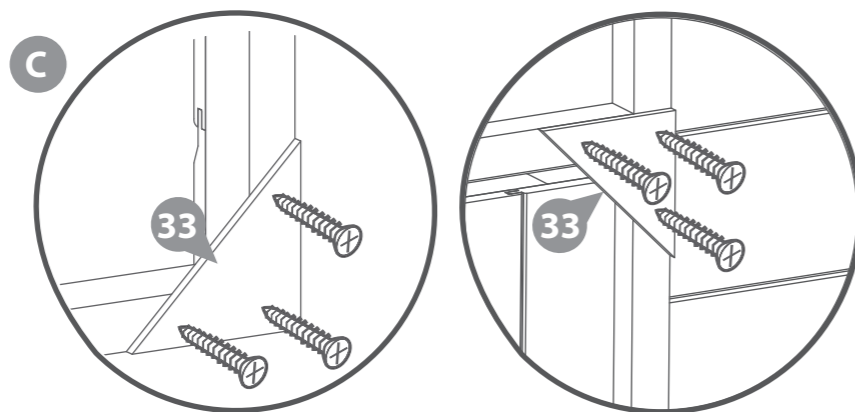

**D** Fix the Butterfly (No. 38) onto to the door using 4x10mm screws.

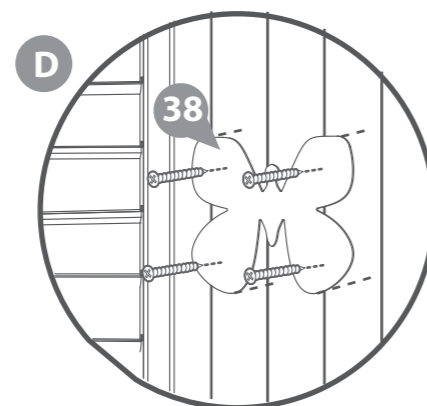

**4x10mm Screws**  
**18x20mm Screws**

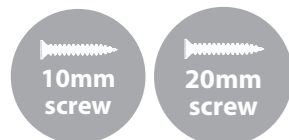

**It is ESSENTIAL that you apply wood treatment immediately after the building has been assembled.**

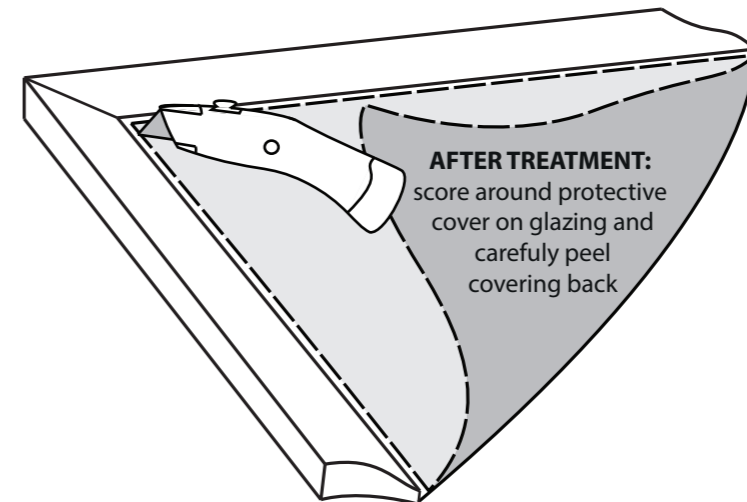

**AFTER TREATMENT:**  
 score around protective cover on glazing and carefully peel covering back

**Playhouse Maintenance:**

It is recommended that the following checks and maintenance are carried out at the beginning of each season as well as at regular intervals during the usage season.

- Check all nuts /bolts/ screws for tightness and tighten when required.
- Check for movement / opening of wood giving rise to protrusion of nail heads and tips.
- Check hinges.
- Replace defective parts in accordance with the manufacturers instructions.
- Check any crossbeams, suspensions and anchors.
- If a swing is included; check the swing seat, chains and ropes.

**IF THESE CHECKS ARE NOT CARRIED OUT THE ACTIVITY TOY COULD BECOME A HAZARD**



# 7x1 Veranda add on Pack B steps:

## Step 20a Parts needed - 42

Place the Veranda Floor (No. 42) on the ground flush to the Door Panel (No. 2) as shown in the illustration.

Ensure the Veranda Floor (No. 42) sits centrally to the building.

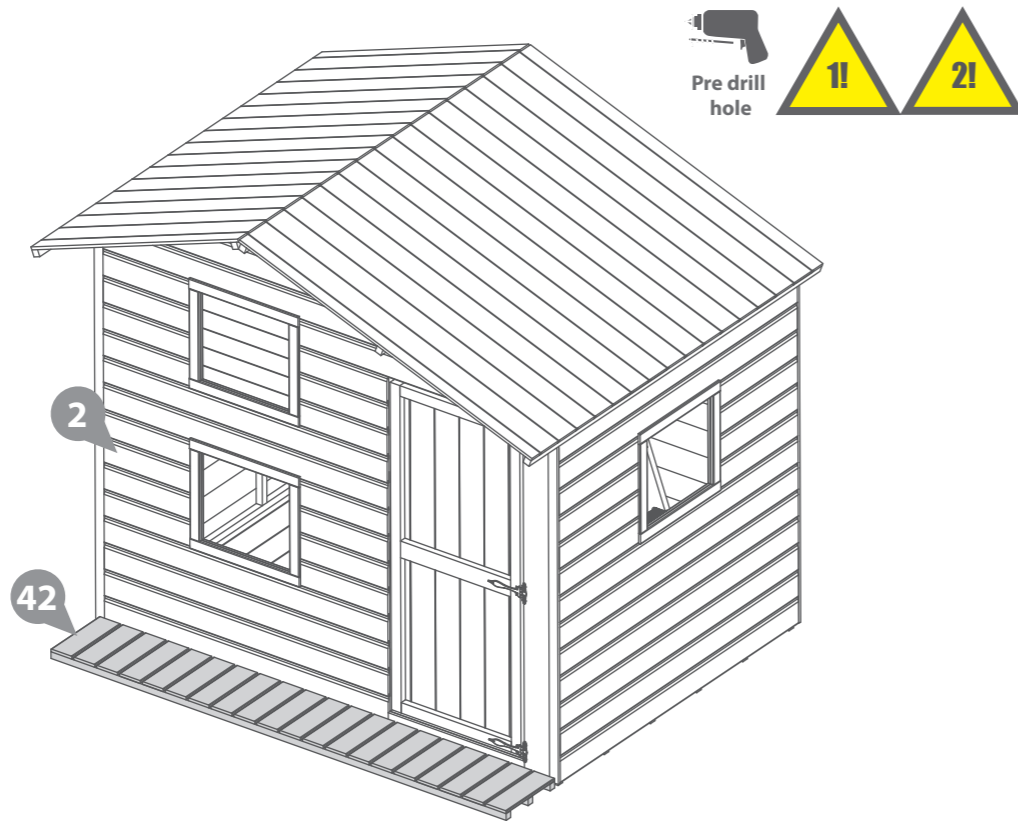

## Step 21a Parts needed - 44

Position the Side Rails (No. 44) on top of the Veranda Floor (No. 42). Ensure they are flush to the Door Panel (No. 2) and the ends of the Veranda Floor (No. 42), as shown in the illustration.

Fix in place by screwing through the Side Rails (No. 44) into the Door panel (No. 2) using 2x50mm screws per side and into the Veranda floor (No. 42) using 2x40mm screws per side.

4x50mm screws.  
4x40mm screws.

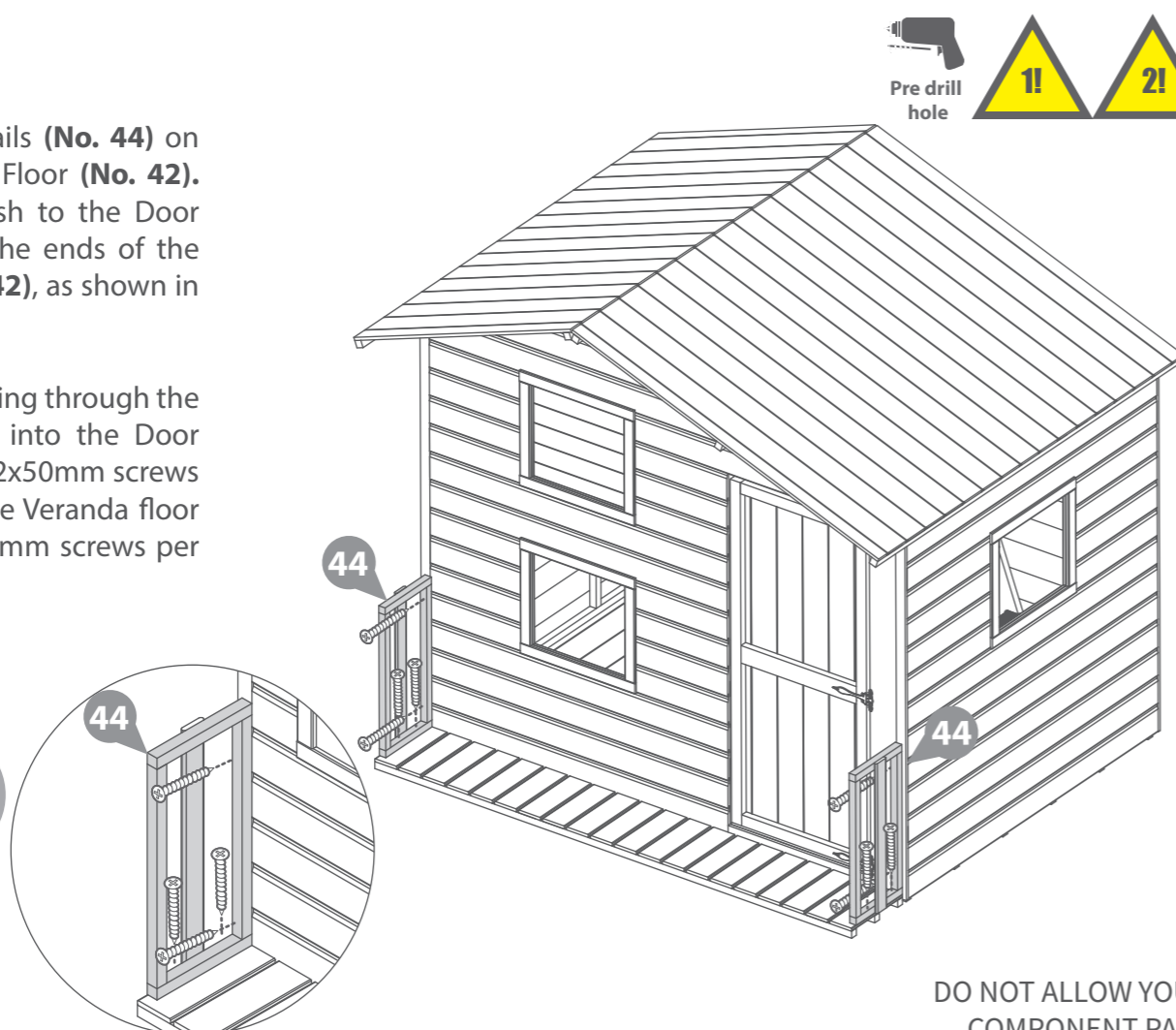

## Step 22a Parts needed - 46 & 47

Position Support Rail B (No. 46) on top of the Veranda Floor (No. 42) and flush to the Left Side Rail (No. 44)

Position Support Rail C (No. 47) on top of the Veranda Floor (No. 42) and flush to the Right Side Rail (No. 44)

Fix in place by screwing through the Support Rails (No. 46 & 47) into the Side Rails (No. 44) and through the roof into the top of the Support Rails using 3x40mm screws per rail.

6x40mm screws.



## Step 23a Parts needed - 43

Position the Front Rail (No. 43) on top of the Veranda Floor (No. 42) on the opposite side to the Door. Ensure the rail is flush to Support Rail B (No. 46), as shown in the illustration.

Fix in place by screwing through Support Rail B (No. 46) using 2x60mm screws and into the Veranda floor (No. 42) using 4x40mm screws, staggering screws to avoid collision.

**Make sure access to the Door is not blocked and that the door can open and close without restriction.**

6x40mm screws.  
2x60mm screws

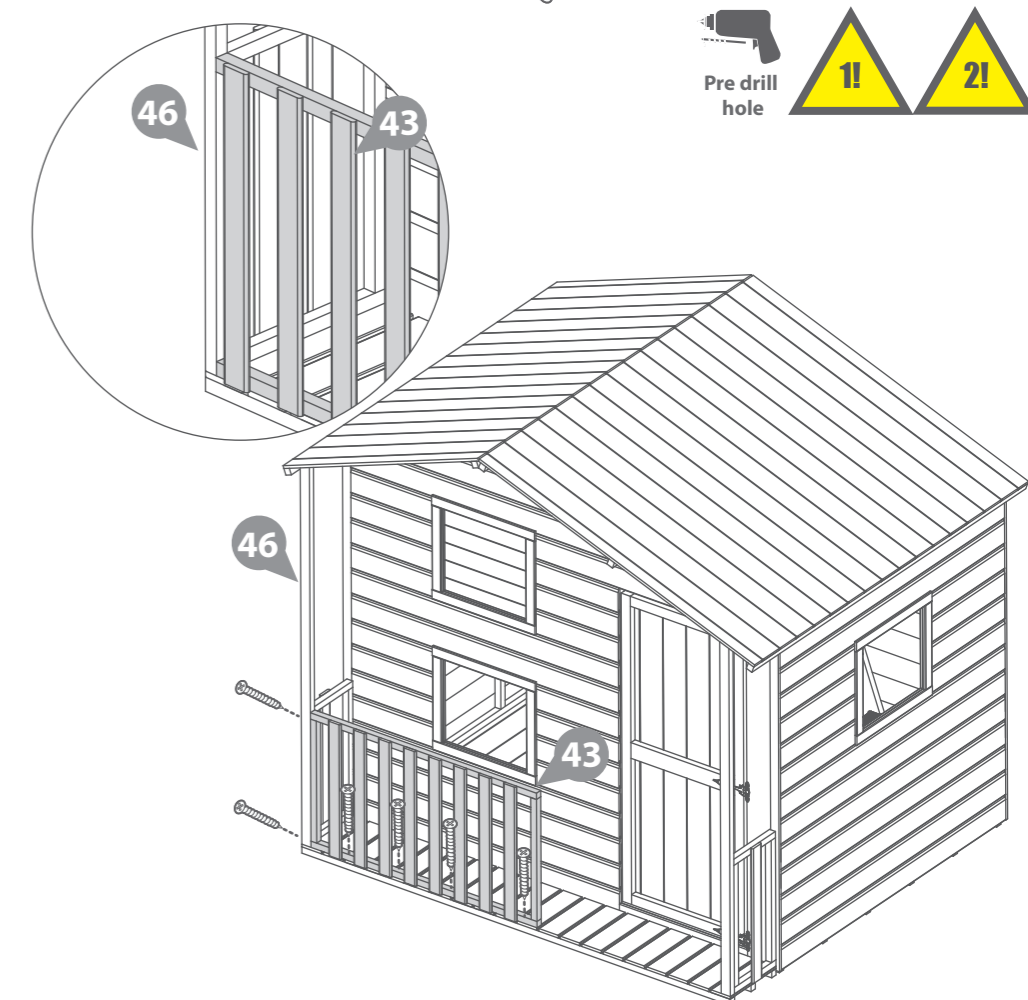
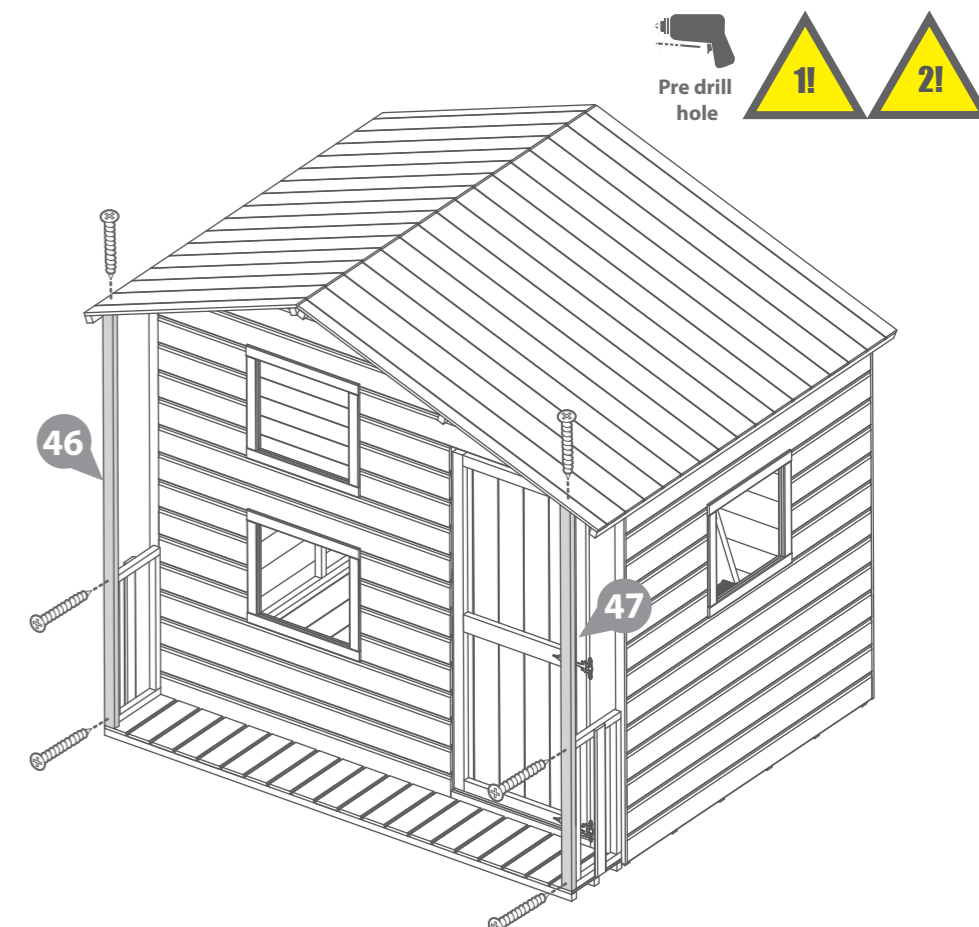

DO NOT ALLOW YOUR CHILD TO PLAY WITH ANY COMPONENT PARTS PRIOR TO ASSEMBLY.

**Step 24a**  
Parts needed - **45**

Position Support Rail A (No. 45) on top of the Veranda Floor (No. 42, and flush to the Front Rail (No. 43)

Fix in place by screwing through the Front Rail (No. 43) into the Support Rail A (No. 45) and through the roof into the top of the Support Rail using 3x40mm screws per rail.

*Make sure access to the Door is not blocked and that the door can open and close without restriction.*

3x40mm screws.

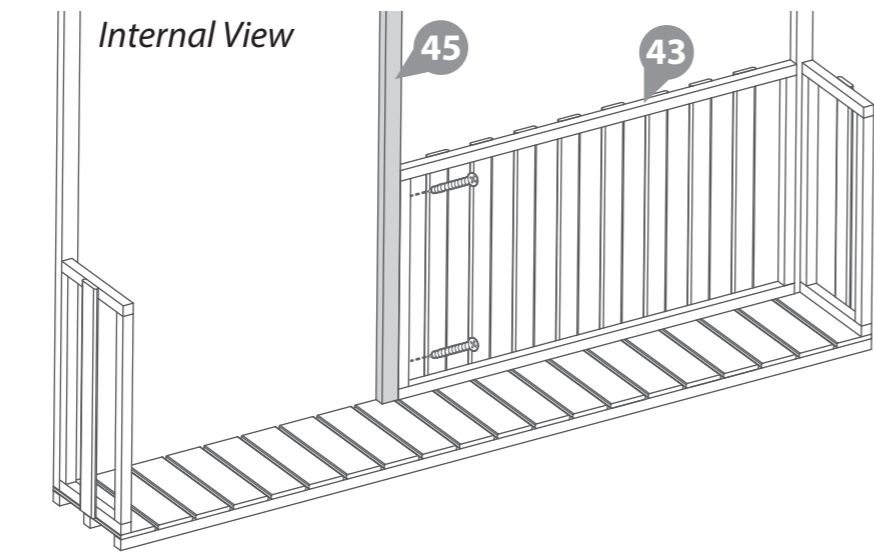
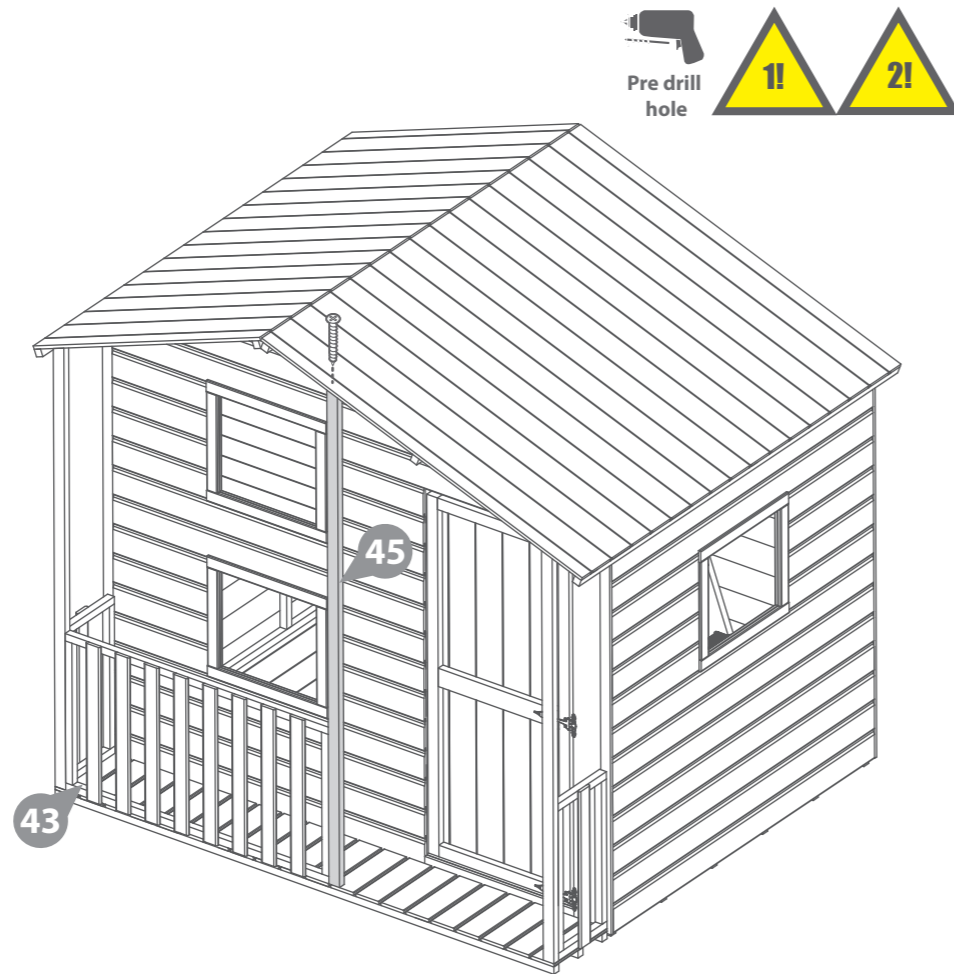

**Step 25a**  
Parts needed - **40**

Cut felt (No. 40) into 3 sheets measuring: **1900mm (L) X 1000mm (W)** and lay onto roof. Start at the bottom of the roof and work your way up so that rain pours over the top of the laps and not under them. Ensure there is a 50mm overhang around the sides.

Fix using felt tacks at 100mm intervals.

**90 Felt Tacks**

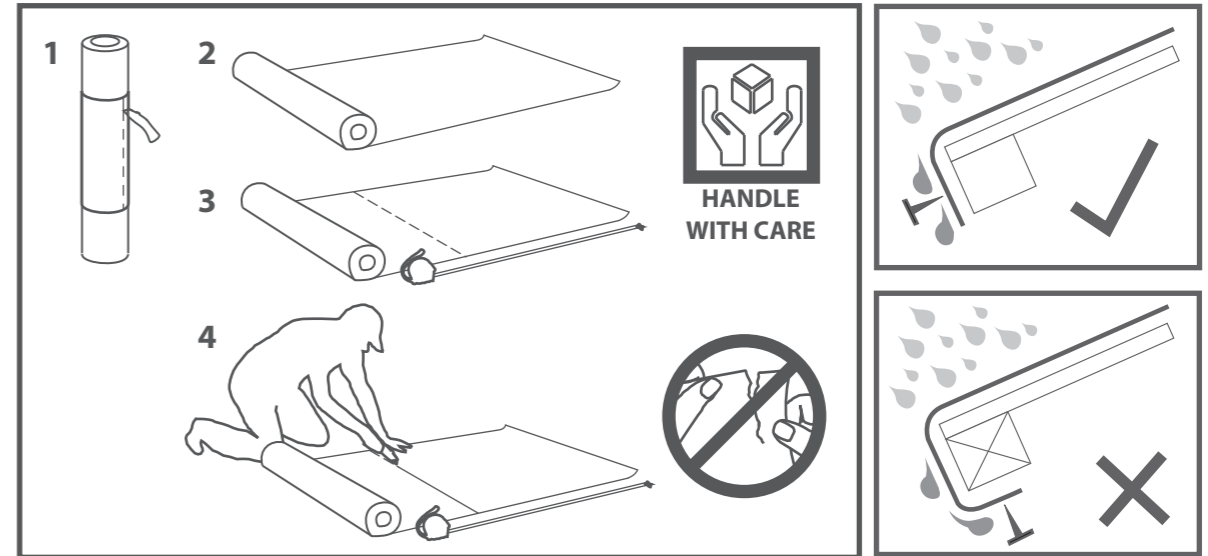
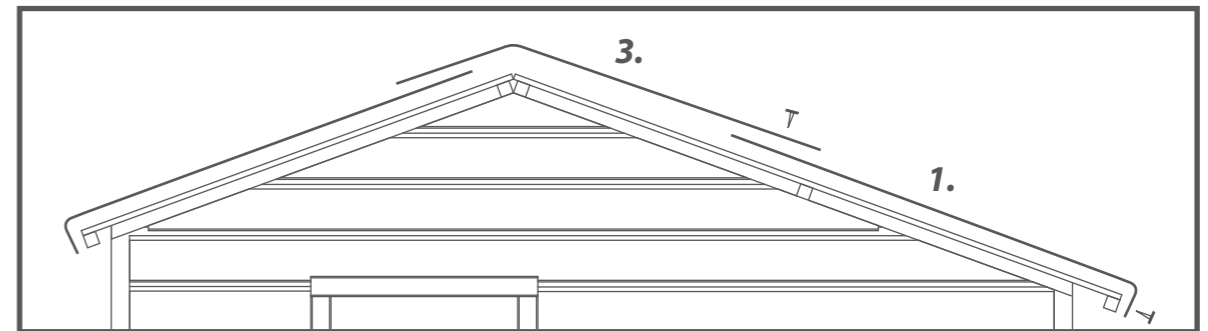
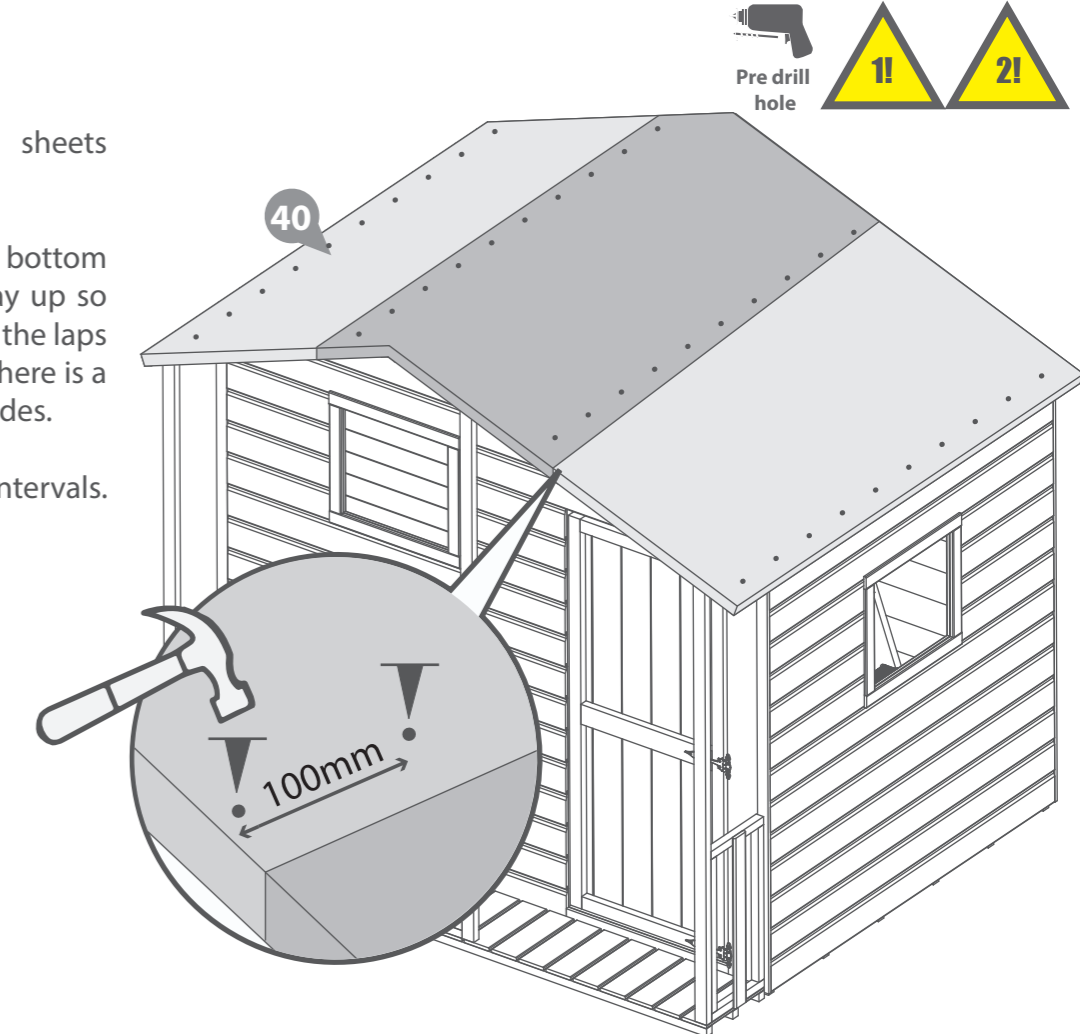

DO NOT ALLOW YOUR CHILD TO PLAY WITH ANY COMPONENT PARTS PRIOR TO ASSEMBLY.

**Step 26a**  
Parts needed - 26 & 27 & 32

Fix the Fascias (No. 25 & 26) to the front and back of the building using 3x40mm screws per Fascia.

Fix the Finials (No.32) centrally over the Fascias using 2x40mm screws per finial.

Ensure to trap the felt between the Fascia and the building.

**16x40mm Screws**

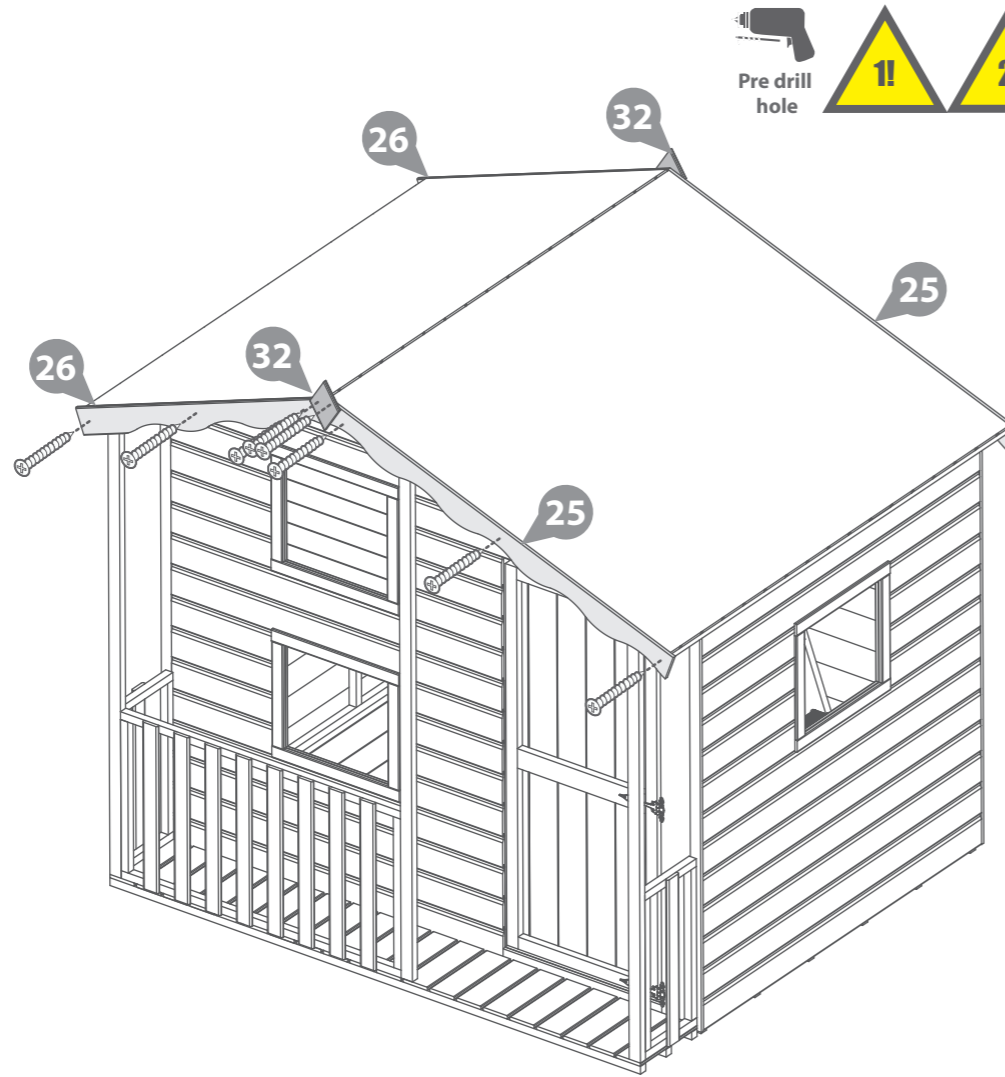

**Step 27a**  
Parts needed - 30 & 31

**A** Locate a Window Box (No.31) onto the Front Rail (No.43) of the Veranda. Secure in place by screwing through the rail framing into the Box framing, using 4x50mm screws.

**B** Locate a Window Box (No.31) below the top window on the Door Panel. Secure in place by screwing from inside the playhouse, through the cladding into the Box, using 4x20mm screws.

**C** Locate 2 Window Shutters (No.30) around the windows on the Door Panel. Secure in place by screwing from inside the playhouse, through the cladding into the Shutter framing, using 6x30mm screws per shutter.

4x50mm screws.  
24x30mm screws.  
4x20mm screws.

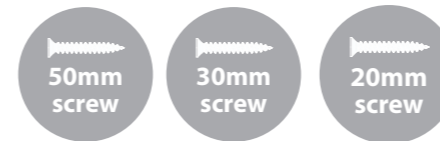

Every effort has been made to reduce sharp edges but it is recommended that any points are rounded.

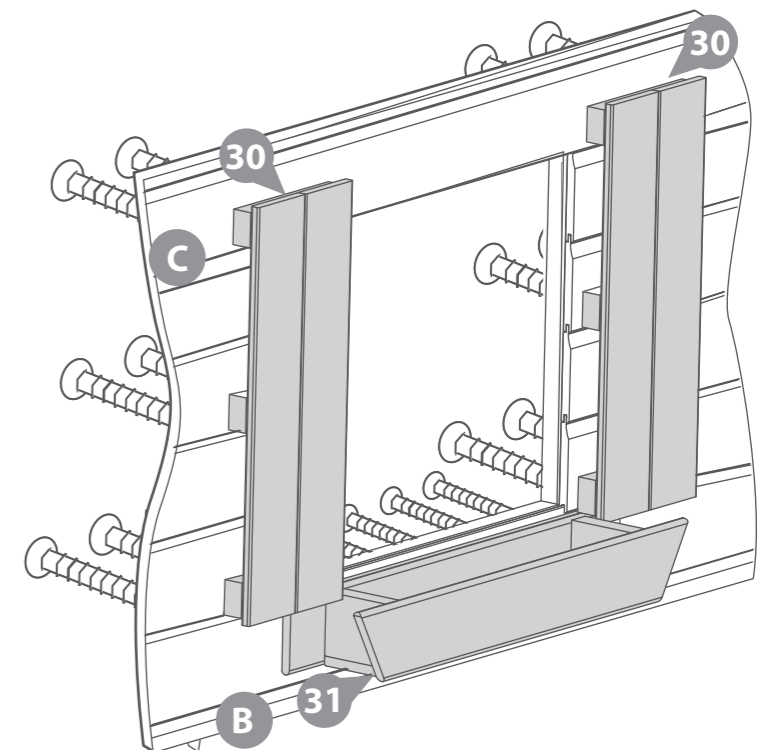
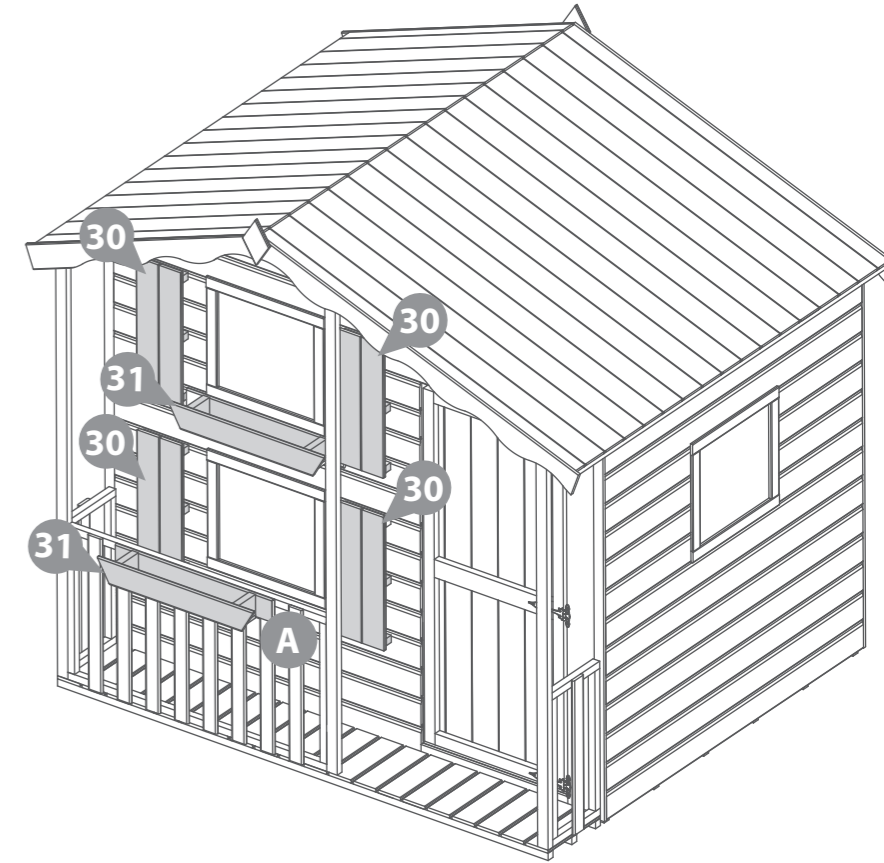

**Step 28a**

**Parts needed - 33 & 34 & 37 & 38**

**A** Place a Window Frame Cross (No. 37) against the inside of each window. Position the frame centrally to the window and fix using 4x20mm screws per frame.

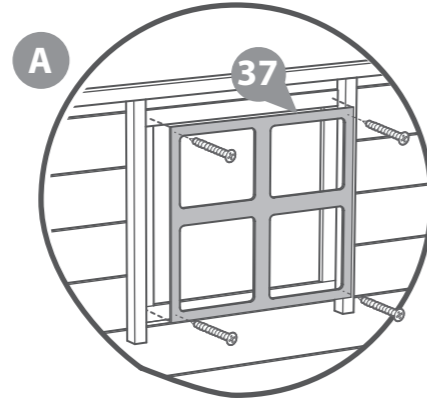

**B** Locate the Wooden Door Handle (No. 34) onto the outside of the door. Fix in place by hand, screwing through the door with the screw attached to the door handle.

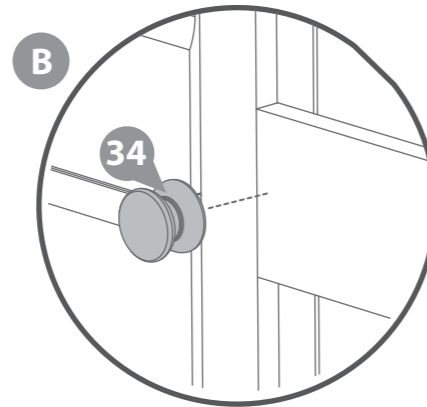

**C** Fix the Door Stop (No. 33) to the inside of the Door Panel at the top and bottom using 3x20mm screws as shown per door stop.

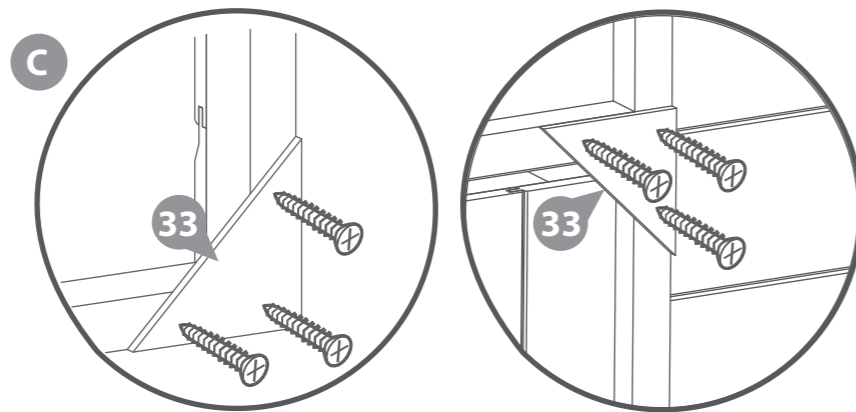

**D** Fix the Butterfly (No. 38) onto the door using 4x10mm screws.

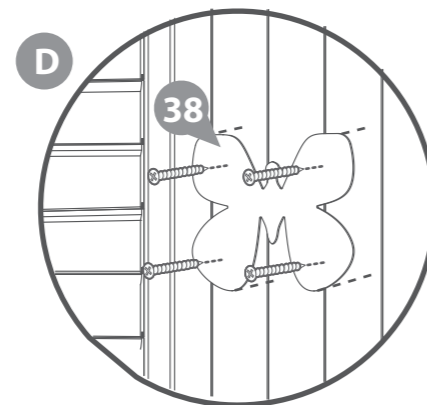

**4x10mm Screws**  
**18x20mm Screws**

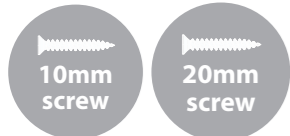

**It is ESSENTIAL that you apply wood treatment immediately after the building has been assembled.**

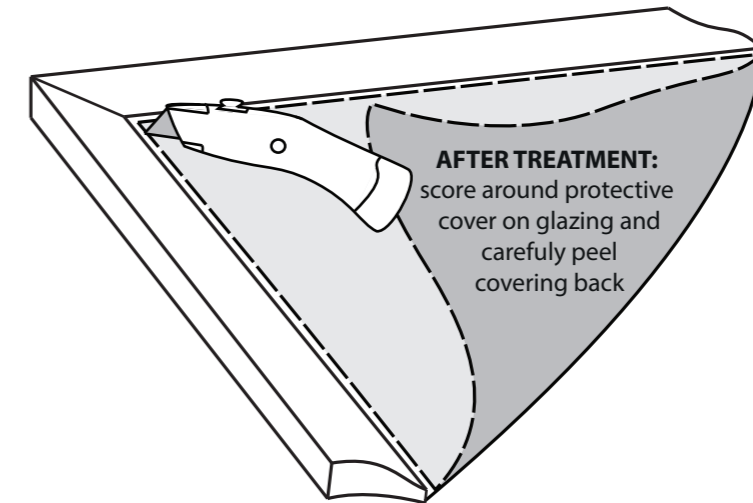

**AFTER TREATMENT:**  
score around protective cover on glazing and carefully peel covering back



**LEAVE US A REVIEW...**

Want to share your experience with us?  
Leave us a review on Feefo, TrustPilot or Google.

Your reviews help other people find and trust our business, as well as helping to play an important role in our growth and improvement!

## TREATING YOUR GARDEN BUILDING

Preservation of wood that's outdoors is vital. A little early care will help protect your garden building, improve its appearance and ensure maximum longevity. Insects, moisture, salt, and changing weather can have dramatic effects on the stability and appearance of your garden building. Once your building is installed, you've checked it over and you're happy with it, you can take a few basic precautions to prepare it for the elements. Treating your garden building helps prevent decay and, by repelling water, discourages the growth of moulds and fungi that could jeopardise the structural integrity of the wood.

**Dip Treated buildings** - Require a preservative treatment to protect against rot and decay and a waterproof treatment to prevent water ingress  
**Pressure Treated buildings** - Require a waterproof treatment to prevent water ingress  
**Log Cabins/Insulated Garden Rooms** - Are supplied untreated and require a preservative and waterproofing treatment.



**ANY QUESTIONS?**  
Scan the QR code to contact us via our customer portal.

To apply a preservative and water proofing treatment (pressure treated products do not require a preserver), follow the manufacturer's instructions but in principle, stick to the following steps:

- ✓ Wear latex or rubber gloves, eye protection and (if spraying) a mask.
- ✓ Prepare the wood, by sanding down any ridges or inconsistencies in the wood, smoothing out knots and end-cuts.
- ✓ Choose a dry day to treat your garden building. If you're spraying rather than brushing paint on, avoid a windy day.
- ✓ Be sure you can safely reach all the sections you need to paint - and if you need a ladder, make sure it's safely positioned before climbing. Lay dust sheets around to avoid paint splatters on your base or surrounding plants.
- ✓ Tape around windowpanes to avoid smears when you're painting the frames.
- ✓ Keep pets and small children out of the way. The last thing you want is to have fur on your garden building paint, or little painted footprints all over your garden and home.
- ✓ Fill any gaps in the building's body with caulk or wood filler to prevent water and draughts getting in. Silicone based caulk is flexible and will move with the timber when temperature and humidity change. Allow to dry completely before treating. A handy tip for finding gaps is to go into your garden building and look for light leaking through joins and frames. If light gets in, then so will water.
- ✓ Liberally apply at least two coats of the treatment products with a brush or spray, taking care to allow the first coat to completely dry before applying the second.
- ✓ Make sure the solution permeates the whole of the surface area, especially around natural cracks, end cuts and nail/screw holes.



APPLY WOOD TREATMENT  
**IMMEDIATELY**  
AFTER ASSEMBLY

PLEASE SCAN HERE TO  
SEE TREATMENT VIDEO:



## 1 Perimeter

Check around the perimeter of your product to ensure there are not trees or plants that are in contact with or overhanging the building. This can affect airflow and overhanging trees, or branches can damage the roof, it is advised to keep plants at a distance.

## 2 Repair

Inspect the interior and exterior of the product to look for splits, cracks, and holes. Although this is a natural occurrence it can be prevented. A wood filler can be used to close the splits, cracks, and holes.

## 3 Roof

Check your roof regularly for tears, splits, damaged wood and fallen debris. If you notice any of this immediate repair is critical.

## 4 Doors & Windows

Expansion and contraction can cause doors and windows to stick or become difficult to open. Small adjustments to the hinge position can be made to the doors and windows to allow free movement.

## 5 Oil

Hinges can seize up over time, apply lubricant to the hinges and locks annually.

## 6 Screws & Bolts

It is advised to check all screws and bolts and tighten any loose you might find. For log cabins specifically the storm braces will require loosening. During humidity and temperature changes (seasons) to allow expansion and contraction to prevent gaping, twisting, popping, and warping.

## 7 Wash

At least once a year, give the outside of you building a good wash, to remove cobwebs, leaves, or any other dirt that may accumulate on the exterior.

## 8 Airing

Airing your product regularly prevents the build up of condensation which can cause the timber to warp, bow, boards to pop, distortion, rot and mould. Condensation can build up over time or daily, it is caused by a rise and fall in temperature.

Excessive moisture levels within your building can cause water to collect on the roofs, walls and floors internally. Leaving doors and windows open regularly can help combat the natural moisture build up.

## 9 Clean & Tidy

It is good practice to clean the inside and outside of your product regularly. Clear out the contents, sweep the floor, remove dirt and cobwebs. Check for areas of damp and investigate the cause to remove and prevent future occurrences. Check the ground around your product for build up of debris such as leaves, remove and ensure there is clear ventilation underneath the floor.

### Additional Playhouse Maintenance:

It is recommended that the following checks and maintenance are carried out at the beginning of each season as well as at regular intervals during the usage season.

- Check all nuts /bolts/ screws for tightness and tighten when required.
- Check for movement / opening of wood giving rise to protrusion of nail heads and tips.
- Check hinges.
- Replace defective parts in accordance with the manufacturers instructions.
- Check any crossbeams, suspensions and anchors.
- If a swing is included; check the swing seat, chains and ropes.

**IF THESE CHECKS ARE NOT CARRIED OUT THE ACTIVITY TOY COULD BECOME A HAZARD**

All our garden buildings have been designed and manufactured with care and attention to be the perfect addition to your outdoor space. To ensure you do get the best out of your new garden building and to increase the longevity we advise that you follow the product instructions and our manufacturer's recommendations as detailed below. Thank you for choosing a Mercia Garden product!

## 1 Choosing the most suitable location for your garden building...

A minimum of 60cm should be left around the perimeter of your garden building to allow access for maintenance, annual treatment and to allow air flow around the building.

Where possible you should avoid placing your garden building underneath large trees to prevent the tree causing damage to the building.

## 2 Preparing the base for your garden building...

All our buildings must be built on a firm, level base to ensure the longevity of the building and prevent the wood from distorting. We recommend either concrete, concrete slabs or a wooden base, such as our 'Portabase'.

The base should be slightly smaller than the external measurement of the building, i.e. the cladding should overlap the base, creating a run off for water and preventing water from pooling underneath the building.

We also recommend that the floor of the garden building is a minimum of 25mm above the surrounding ground level to avoid flooding.

## 3 After installation...

Once your garden building has been installed, it will need to be treated within 14 days (weather permitting) and annually to prevent the timber from deteriorating and to waterproof it. This is required to maintain the anti-rot guarantee.

Dip Treated buildings - Require a preservative treatment to protect against rot and decay

and a waterproof treatment to prevent water ingress.

Pressure Treated buildings - Require a waterproof treatment to prevent water ingress.

Log Cabins/Insulated Garden Rooms - Are supplied untreated and require a preservative and waterproofing treatment.

We also recommend using a silicon sealant on the inside and outside of the windows as soon as possible after assembly and treatment to fully seal the windows.

Roofing felt/covering should be checked annually and replaced or fixed accordingly.

## 4 General maintenance and wood characteristics

As wood is a natural material it may be affected by the following:

**Shrinkage and warping** - The timber used in the construction of your garden building will have retained some of its natural moisture content. The moisture content of the timber will vary, depending upon prevailing environmental conditions, which will result in the components either naturally expanding or contracting. As the components dry out, shrinkage may occur. A good waterproofing treatment from the start is the best protection to minimise the effect of moisture loss/intake.

In extended periods of very warm weather getting some moisture to the building will help the overall balance. You can do this by spraying it down lightly with a garden hose. In contrast, after snow fall try to remove the snow as best as possible from the roof to prevent moisture intake and to remove the extra weight.

Top tip - using a garden brush will help you to reach the highest part of the building to remove snow and any debris left from bad weather.

**Damp and mould** - During the winter months, cold and damp conditions can result in an increased amount of moisture within your garden building, especially when used infrequently. Condensation can form on the timber and other items stored within your garden building. If left this moisture is likely to cause mould and mildew.

To prevent the build-up of moisture, we recommend leaving the door or windows of your building open from time to time, to allow the fresh air to circulate. We also advise against storing wet or damp items in your garden building as this will also increase the level of moisture in the building. If mould or mildew does start to form within your building we recommend using an anti-mould cleaner to remove it and to prevent it spreading, which if left untreated could permanently damage your garden building.

**Splits, cracks and knots** - You may notice small splits and cracks in some components or holes may appear where knots shrink and fall out. This will not affect the structure of your Garden building however, if you wish to fill them this can be easily done using any good quality wood filler.

**Sap** - is naturally occurring in wood and may appear in some boards of your garden building. If you wish to remove the sap, we advise waiting until it is dry and then using a sharp knife to carefully remove it. If the removal of the sap causes a hole in the timber, we recommend using a good quality wood filler to fill it.

For more handy hints and tips on how to care and maintain your garden building please refer to the MGP Customer Portal at [www.mgplogistics.co.uk](http://www.mgplogistics.co.uk)

### Any further questions?

Contact our  
Customer Service Team via the MGP  
Customer Portal at:  
[www.mgplogistics.co.uk](http://www.mgplogistics.co.uk)

## 1

### Manufacturer's Warranty

All Mercia Garden Products are supplied with a 1 year warranty on all parts against manufacturing defects.

This warranty does not cover movement, warping or splitting of timber products over time.

This warranty will be voided if any of the following occur:

1. The building has been customised or modified/adapted in any way.
2. The person claiming is not the original purchaser of the building.
3. Any damage has been caused by or as a result of misuse.
4. The building has not been maintained and cared for in accordance to our advisories and manufacturer's recommendations.
5. The building has not been treated annually or as per the manufacturer's recommendations, please ensure receipts are kept to validate this claim.
6. The building has not been erected, fitted or installed as per the supplier instructions.
7. The building has not been erected on a suitable sized firm flat, solid level concrete/slab base or placed on pressure treated bearers.
8. The building is or has been placed with 2 feet (600mm) of any obstructions (walls, trees, plants, fences etc.) which can allow moisture to penetrate the timber.
9. The roofing felt has been incorrectly fitted or damaged, allowing water ingress, or has not been properly maintained.
10. Any windows and joints have not been sealed, inside and out, with silicone or other watertight sealant.
11. Any timber has been cut, pierced or drilled without subsequent application of approved cut-end treatment.

## 2

### Anti-rot Guarantee

Mercia Garden Products offer a 10 year anti-rot guarantee on all dip treated (a preparatory treatment) and 15 years on all pressure treated products. This guarantee covers solid timber against rot, decay, blue stain and insect attacks.

To validate the guarantee the building must be treated (as detailed within manufacturer's recommendations) within 14 days (weather permitting) of assembly and annually thereafter.

This guarantee does not cover movement, warping or splitting of timber products over time.

This guarantee will be voided if any of the following occur:

1. The building has been customised or modified/adapted in any way.
2. The person claiming is not the original purchaser of the building.
3. Any damage is caused by or as a result of misuse.
4. The building has not been maintained and cared for in accordance to our advisories and manufacturer's recommendations.
5. The building has not been treated annually or as per the manufacturer's recommendations, please ensure receipts are kept to validate this claim.
6. The building has not been erected, fitted or installed as per the supplier instructions.
7. The building has not been erected on a suitable sized firm flat, solid level concrete/slab base or placed on pressure treated bearers.
8. The building is or has been placed with 600mm of any obstructions (walls, trees, plants, fences etc.) which can allow moisture to penetrate the timber.
9. The roofing felt has been incorrectly fitted or damaged allowing water ingress, or has not been properly maintained.
10. Any windows and joints have not been sealed, inside and out, with silicone or other watertight sealant.
11. Any timber has been cut, pierced or drilled without subsequent application of approved cut-end treatment.



REGISTER FOR YOUR  
**ANTI-ROT**  
GUARANTEE TODAY

PLEASE SCAN HERE:

