

SI-100-001-0006

10X8 APEX / REVERSE APEX SHIPLAP SHED.

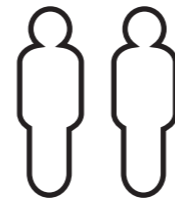

x2

All buildings should be erected by two adults

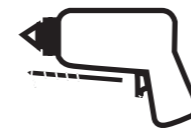

2mm Drill bit

For ease of assembly, you **MUST** pilot drill all screw holes and ensure all screw heads are countersunk.



For ease of assembly, you will need a tape measure to check dimensions of components and fixings.



Winter = High Moisture = Expansion
Summer = Low Moisture = Contraction



CAUTION

Every effort has been made during the manufacturing process to eliminate the prospect of splinters on rough surfaces of the timber. You are strongly advised to wear gloves when working with or handling rough sawn timber.

****Protim Aquatan T5 (621)****

Your building has been dip treated with Aquatan.

Aquatan is a water-based concentrate which is diluted with water, the building has been treated by the correct application of Aquatan solution and then allowed to dry.

Aquatan is a decorative finish to colour the wood, which is applied industrially to timber fence panels and garden buildings.

Aquatan undiluted contains: boric acid, sodium hydroxide 32% solution, aqueous mixture of sodium dioctyl sulphosuccinat and alcohols: 2, 4, 6-trichlorophenol.

REGISTER FOR YOUR
10 YEAR
ANTI-ROT
GUARANTEE TODAY

In all instances for assistance with your product or to register your anti rot guarantee, please contact us via our customer portal



www.mgplogistics.co.uk

Mercia Garden Products Limited, Sutton On Trent, Newark, Nottinghamshire, NG23 6QN

Screws & Nails

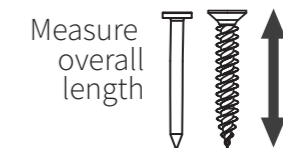

Bolts



BEFORE YOU START PLEASE READ THE INSTRUCTIONS CAREFULLY

- Check the pack and make sure you have all the items listed in the parts list provided.
- When you are ready to start, make sure you have the right tools at hand (not supplied - see the equipment list on next page).
- Ensure there is plenty of space and a clean dry area for assembly.
- Ensure you have enough time to build the product to ensure the building is water tight.

LOCATION FOR YOUR GARDEN BUILDING

A minimum of 600mm should be left around the perimeter of your garden building to allow access for maintenance, annual treatment and to allow air flow around the building.

Where possible you should avoid placing your garden building underneath large trees to prevent the tree causing damage to the building.

BUILDING A BASE

When thinking about where the building and where the base is going to be constructed: Ensure that there will be access to all sides for maintenance work and annual treatment.

Ensure the base is level and is built on firm ground, to prevent movement. Refer to the contents page for the base dimensions. The base should be slightly smaller than the external measurement of the building, i.e. The cladding should overlap the base, creating a run off for water. It is also recommended that the floor be at least 25mm above the surrounding ground level to avoid flooding.

TYPES OF BASE

- Concrete 75mm laid on top of 75mm hard-core.
- Slabs laid on 50mm of sharp sand.
- Wooden base - Levelled / on posts / ground screws.

TREATMENT

Once your garden building has been installed it will need to be treated within 14 days (weather permitting) and annually to prevent the timber from deteriorating and to waterproof it. This is required to maintain the anti-rot guarantee.

Dip Treated buildings - Require a preservative treatment to protect against rot and decay and a waterproof treatment to prevent water ingress

Pressure Treated buildings - Require a waterproof treatment to prevent water ingress

Log Cabins/Insulated Garden Rooms - Are supplied untreated and require a preservative and waterproofing treatment.

TIMBER

As with all natural materials, timber can be affected during various weather conditions. For the duration of heavy or extended periods of rain, swelling of the wood panels may occur. Warping of the wood may also occur during excessive dry spells due to an interior moisture loss. Unfortunately, these processes cannot be avoided but can be helped. It is suggested that the outdoor building is sprayed with water during extended periods of warm sunshine and sheltered as much as possible during rain or snow.

TO DO LIST

- Find a suitable location to build (*see front cover for further information*).
- Build a base (*see front cover for further information*).
- Check the base is flat, level, clear of debris and has 60cm clearance on all sides.
- Check you have the required equipment / tools.
- Check you have all the product items listed (*if you have missing or damaged parts please scan the QR code below to visit our online customer portal*).
- Install the product as per the step by step instructions within this pack.
- Prepare the product ready for treatment (this may include sanding).
- Apply a preserving and a waterproofing treatment within 14 days (*weather permitting*) of installation (*pressure treated products do not require a preserver*).
- Register for your anti rot guarantee (*scan the QR below*).
- Tidy the build area and dispose of any remaining parts responsibly.
- Maintain your building (*see the manufacturers recommendations at the back of this pack*).

EQUIPMENT LIST

- Hammer
- Flat Head Screwdriver
- Drill
- Drill Bit Set
- Phillips and Slotted Bit Sets
- Tape Measure
- Hand Saw
- Spirit Level
- Ladders/Steps
- Stanley Knife/Cutting Tool
- Sand Paper
- Gloves
- Silicone (For Windows Only)
- Sealant Application Gun
- Wood Filler (Optional)
- Timber Preservative Treatment (*not pressure treated products*)
- Timber Water Proofing Treatment
- Treatment Mixing Stick
- Paint Brush/Sprayer/Roller

NEED EXTRA SUPPORT

If you are unsure that your base preparation will be suitable, please contact us via our customer portal to discuss this further.

Alternatively, you can visit our website or MGP Logistics Online Portal for some further shededucation.

Website:

<https://www.merciagardenproducts.co.uk/sheducation>

MGP Logistics Online Portal:

<https://www.mgplogistics.co.uk/>

Here you will find plenty of useful information that'll help with most pre-installation and maintenance queries.

**ANY QUESTIONS?**

Scan the QR code to contact us via our customer portal.

NOTES

ACCESSING VIDEO GUIDES...

Some steps within this set of instructions come with an added video guide for your convenience. These can be accessed via the QR code and used to aid you in constructing that step. See below for how to use.

You can also find all the videos on our youtube channel:
<https://www.youtube.com/@merciagardenproducts8716/videos>

1. Find the QR code within the instruction step...

Step.....

Parts Needed- No. QTY 1
No. QTY 1
No. QTY 1

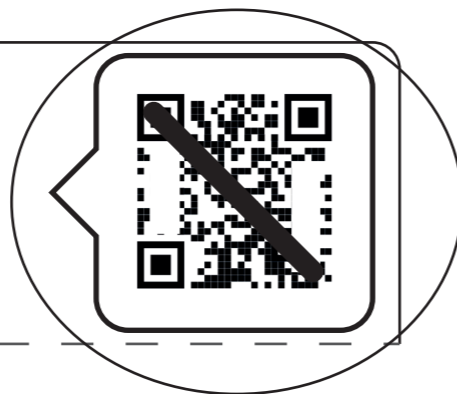

Within the instruction step, there will be an icon in the top right that has a QR code in. This is where the video can be accessed from.

Please note: not every step has a video guide.

2. Open camera app...

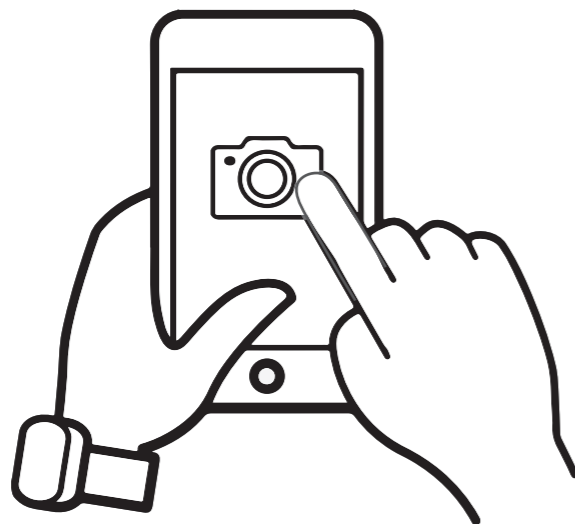

On your personal smart device (phone, tablet etc), open your camera app or QR code scanner app.

ACCESSING VIDEO GUIDES...

3. Scan QR code...



To scan the QR code, hold the camera over the QR code so that it can be seen on the screen. Once the QR code has been registered, follow the prompts on your device to open the video. (This will vary depending on your device.)

Please note: Ensure to use the back camera of your smart device as this will scan the QR code more accurately.

4. Watch the video...



The video guide will now be displayed on your smart device.

Disclaimer: The garden building constructed in the video guides may be constructed differently to your building. Please ensure to read your instructions carefully to avoid error.

What is a Modular Shed?

This Modular shed allows you to choose the layout of your shed, yourself.

The 4ft Door, Window and Plain Panels (No. 4a, 4b & 4c) are all interchangeable, and can be swapped and positioned however you choose.

Please note: The buildings shown may differ in size from your chosen building however the process of interchanging the Panels is the same.

Overall Dimensions: Width = 2495mm
Depth = 3094mm
Height = 2369mm

Base Dimensions: Width = 2350mm
Depth = 3023mm

Door on the side.

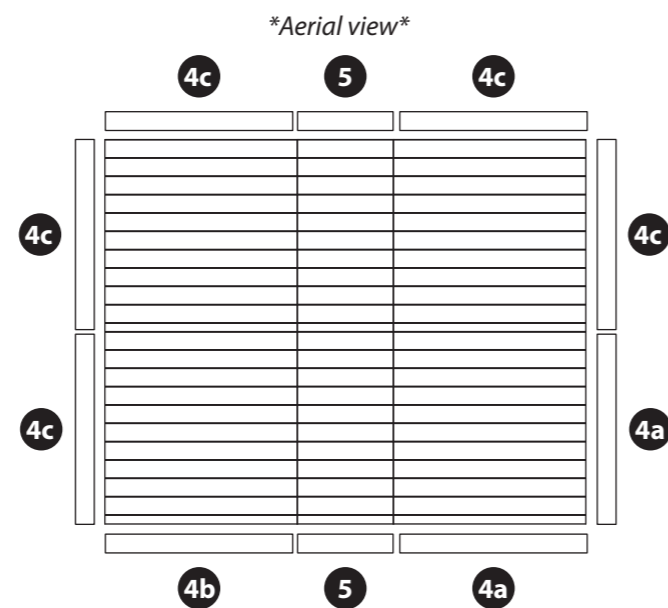
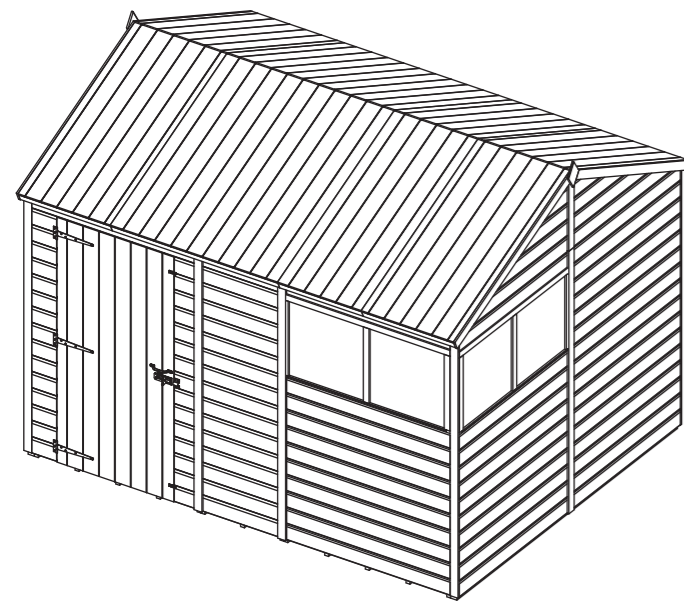

Door on the end.

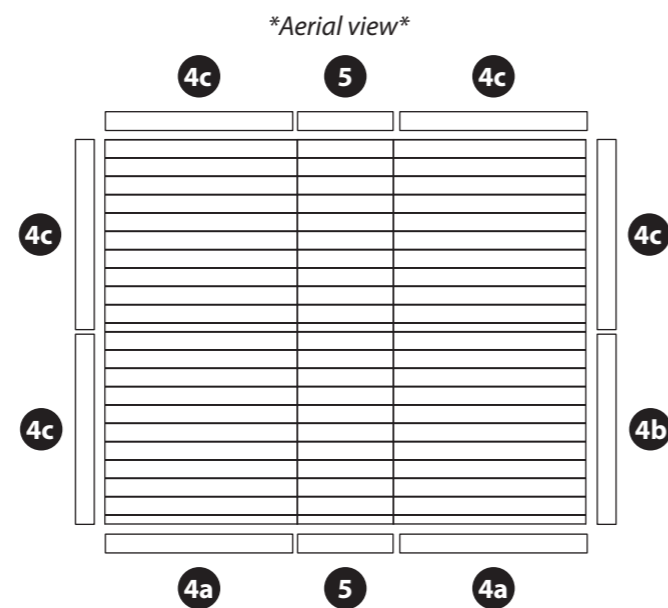
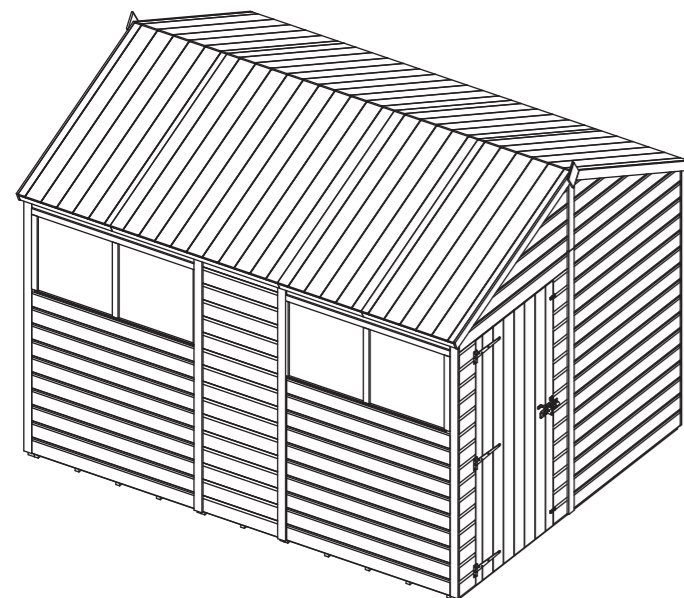

Building Contents:

Tip: Labelling your parts, using a pencil and masking tape, may help you to identify them easier when you need them.

NO.1 FLOOR PANEL

1

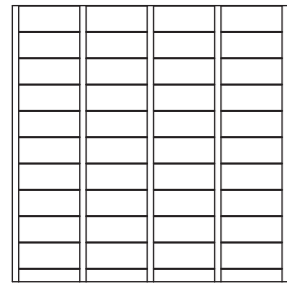

Floor QTY 4
SU-S21MBF1175X1175-V1

2

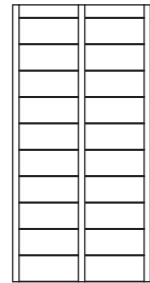

Floor QTY 2
SU-S21MBF1175X585-V1

3

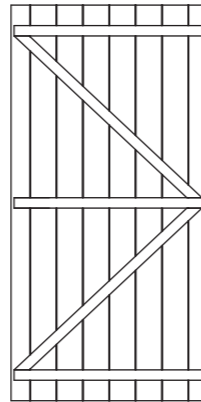

Door QTY 1
SU-S21FBMBZBD824X1680-V1

4a

4b

4c

5

Please note: The 4ft door, window and plain panels (No. 4a, 4b & 4c) are interchangeable, and can be swapped and positioned however you choose.

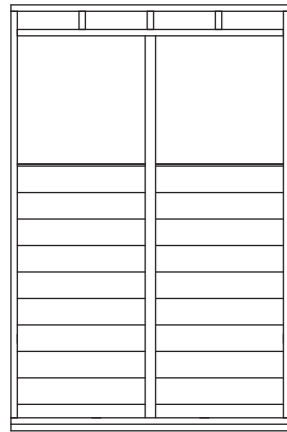

4ft Window Panel QTY 2
SU-01S21SH2CW1180X1802-V1

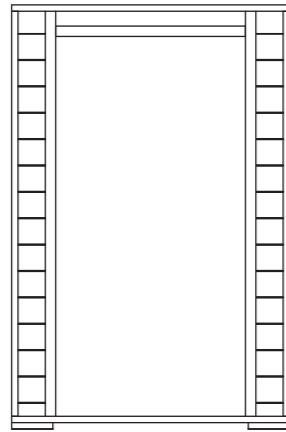

4ft Door Panel QTY 1
SU-01S21SHSD1180X1802-V1

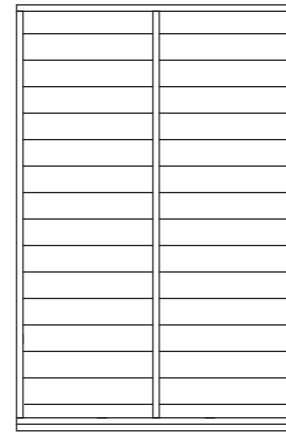

4ft Plain Panel QTY 5
SU-S21SHPPTF1180X1802-V1



2ft Plain Panel QTY 2
SU-S21SHPPTF590X1802-V1

6

7

8

9

10

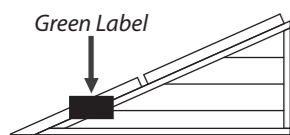

Right Gable Top QTY 2
SU-S21SHHAGTR1180X519-V1

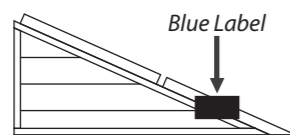

Left Gable Top QTY 2
SU-S21SHHAGTL1180X519-V1

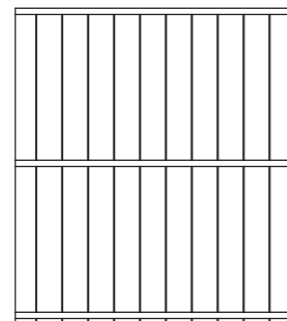

4ft Roof QTY 2
SU-S21MBOHAR1360X1180-V1

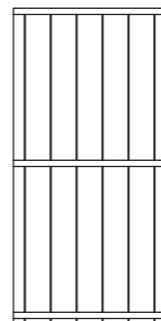

Large 2ft Roof QTY 4
SU-S21MBOHAR1360X650-V1

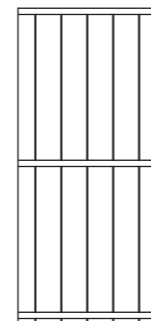

Small 2ft Roof QTY 2
SU-S21MBOHAR1360X590-V1

11

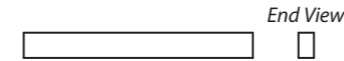

Floor Block - 27x44x400mm QTY 10
F2744-400mm

12

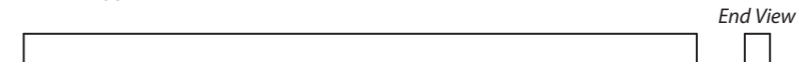

Floor Extension Joist - 44x56x1175mm QTY 4
F4456-1175mm-DT

13

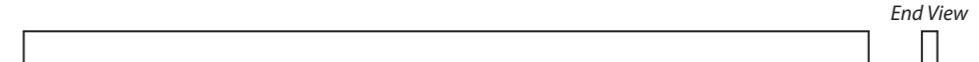

Ridge Bar - 27x70x1475mm QTY 2
F2770-1475mm-DT

14

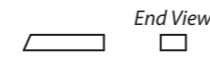

Truss Block - 27x44x140mm QTY 2
F2744-G-160mm (Finished length 140mm, 1 x angled cut)

15

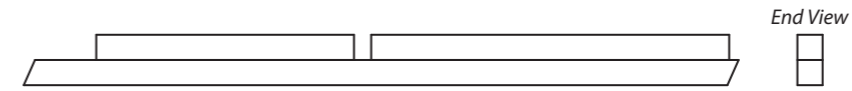

Truss Frame - 44x88x1248mm QTY 2
SU-S22HAXT1248X88-V1

16

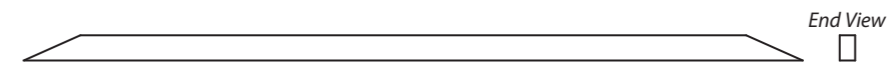

Truss Support - 27x44x1360mm QTY 2
F2744-G-1400mm (Finished length 1360mm, 2 x angled cuts)

17

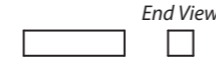

Truss Support Block - 44x44x176mm QTY 2
F4444-176mm

*You may have more of this part than required.

18

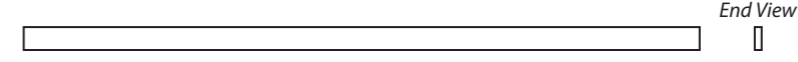

Top Window Strip - 12x40x1180mm QTY 2
S1240-1180mm

19

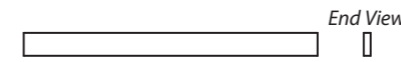

Window Strip - 12x40x513mm QTY 10
S1240-513mm

20



Plastic Window Cill QTY 2
PI-08-0013

21



Styrene QTY 4
PI-05-0114

22

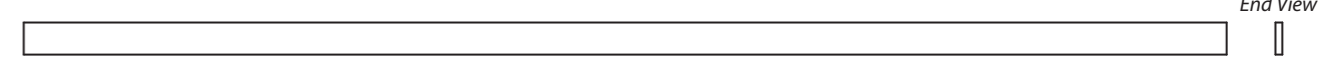

Cover Trim - 12x56x2100mm QTY 12**
S1256-2100mm

*You may have more of this part than required.

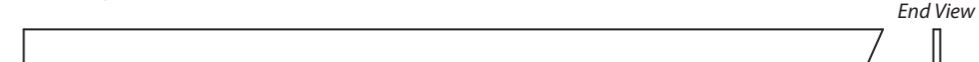

23



Fascia - 12x60x1500mm QTY 4**
S1260-G-1500mm (1 x angled cut)

24  **Finial QTY 2**
Shed Diamond Finial

28  **Pad Bolt QTY 1**
PI-07-0035

32   **Door Block - 27x44x150mm QTY 2**
F2744-150mm

25  **T-Hinge QTY 3**
PI-07-0021

29  **Door Handle QTY 1**
PI-07-0240

26  **U-Channel QTY 7**
PI-07-0013

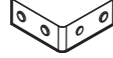
30  **Corner Brace QTY 2**
PI-07-0012







27  **Turn Button QTY 2**
PI-07-0034

31  **Felt QTY 1****

****This part will be longer than needed and requires cutting to size when used. This will be explained when required within the instruction step.**

Screw Pack:



There may be extra screws in the pack.

-  **70mm Screw x 10**
-  **40mm Screw x 96**
-  **60mm Screw x 20**
-  **30mm Screw x 205**
-  **50mm Screw x 112**
-  **Felt Tacks x 150**

Panel Brace Kit Contents:

SU-S214X540BRC-V1-FK

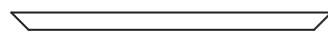
If you have purchased a 'Panel Brace' add-on kit, please see below for the pack contents.

33   **Panel Brace QTY 16**
F2744-G-540mm
**You may have more of this part than are required.*

Screw Pack:

There may be extra screws in the pack.

-  **40mm Screw x 32**



Missing parts?
Scan the QR code to visit our customer portal where you can quickly raise any missing or damaged parts and get a replacement sent out ASAP.



Before assembly, please make sure you have a suitable base ready to install your building onto.

IMPORTANT: Pre-drill before fixing screws.



Pre-Assembly - Panel Brace add-on ONLY.

If you have not purchased a 'Panel Brace' add-on kit, please skip to step 1.

- Parts needed - No. 4a QTY 2**
No. 4c QTY 5
No. 5 QTY 2
No. 33 QTY 16

Place the 4ft Window Panels (**No. 4a**), 4ft Plain Panels (**No. 4c**) and 2ft Plain Panels (**No. 5**) face down on a flat and level base.

At the bottom of each panel, locate the Panel Braces (**No. 33**) onto the internal cladding of the panels and up to the framing, ensuring the framing is flush and level, as shown.

****Tip: To identify the bottom of the panel, look for where the cladding overhangs past the framing. This is the bottom of the panel.**

The 4ft Panels (**No. 4a & 4c**) should have two braces per panel and the 2ft Panels (**No. 5**) should have one brace per panel, as shown.

Secure the Braces (**No. 33**) in place by screwing through the outside of the panel framing into the brace behind using 1x40mm screw per end, as shown.

32x40mm Screws



IMPORTANT: Pre-drill before fixing screws.

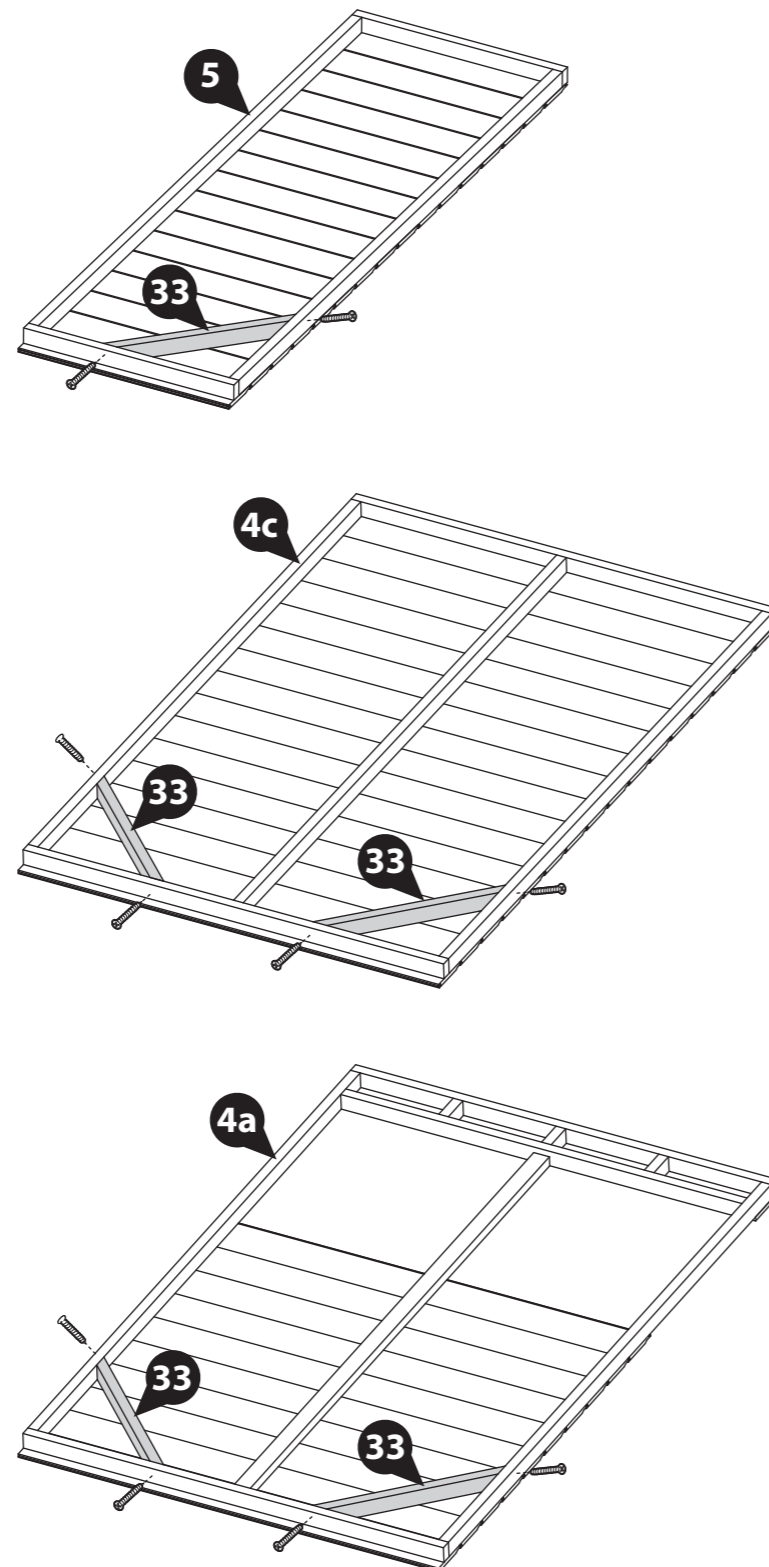

Step 1

- Parts needed - No. 3 QTY 1**
No. 4b QTY 1
No. 25 QTY 3

Place the 4ft Door Panel (**No. 4b**) face up onto a flat and level base.

Place the Door (**No. 3**) within the 4ft Door Panel (**No. 4b**), ensuring there is equal spacing on each side.

Locate the T Hinges (**No. 25**) onto the Door and Door Panel, ensuring the hinge lines up with the framing on the inside of the Door.

Secure in place using 7x30mm screws per hinge, ensuring that the screws go through the cladding and into the framing behind.

****PLEASE NOTE**** Before fitting the hinges, ensure the Door is in the correct position depending on which side you want the Door to open. See the illustrations below which show the Doors internal framing.

21x30mm Screws

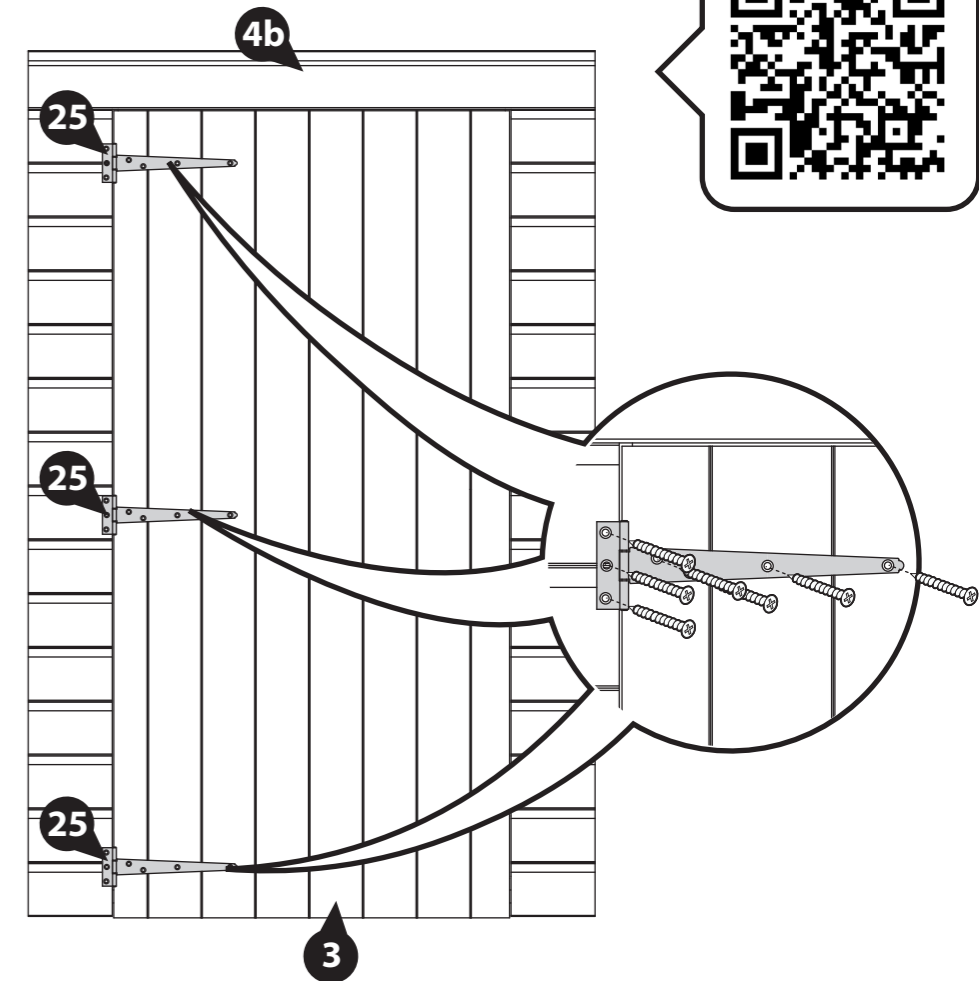

Opens from the Left

Opens from the Right

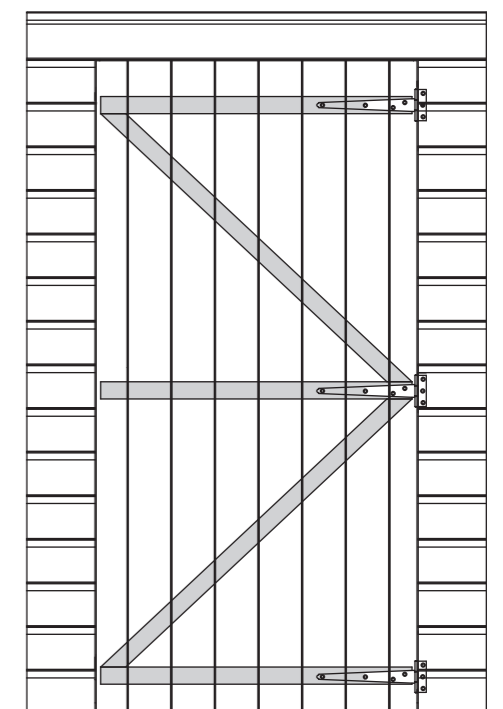
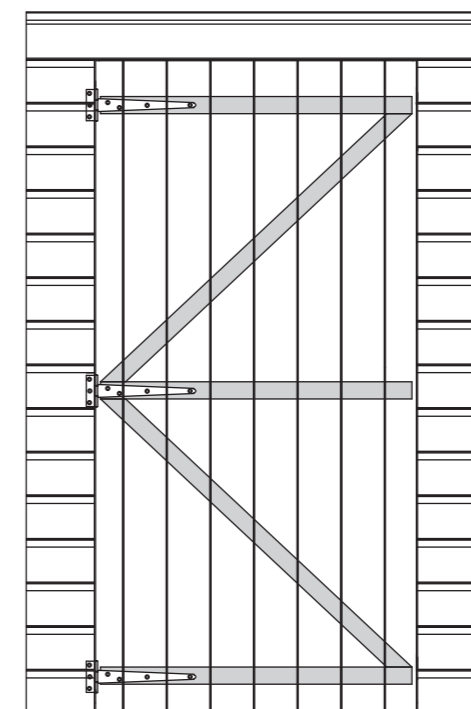

Step 2

Parts needed - No. 3 QTY 1
No. 32 QTY 2

Please note: Your Handle can be positioned horizontally or vertically. Please decide which works best before fitting your door blocks. Follow the relevant step below depending on your choice.

Position one Door Block (No. 32) horizontally underneath the central piece of framing on the Door (No. 3), ensuring the ends and sides are flush.

Ensuring to support the Block, secure in place using 2x30mm screws, screwing through the outside of the Door cladding into the block behind.

Horizontal handle:

Locate the second Door Block (No. 32) on the top of the central piece of framing, on the opposite side to the already fitted block. Ensuring the ends and sides are flush, secure in place using 2x30mm screws, screwing through the outside of the Door cladding into the block behind.

Vertical handle:

Locate the second Door Block (No. 32) vertically on the top of the central piece of framing, on the opposite side to the already fitted block. Ensuring the ends and sides are flush, secure in place using 2x30mm screws, screwing through the outside of the Door cladding into the block behind.

4x30mm Screws

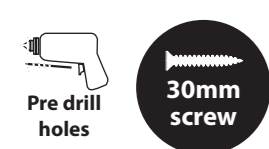

IMPORTANT: Pre-drill before fixing screws.

Horizontal Handle:

Opens from the Left

Opens from the Right

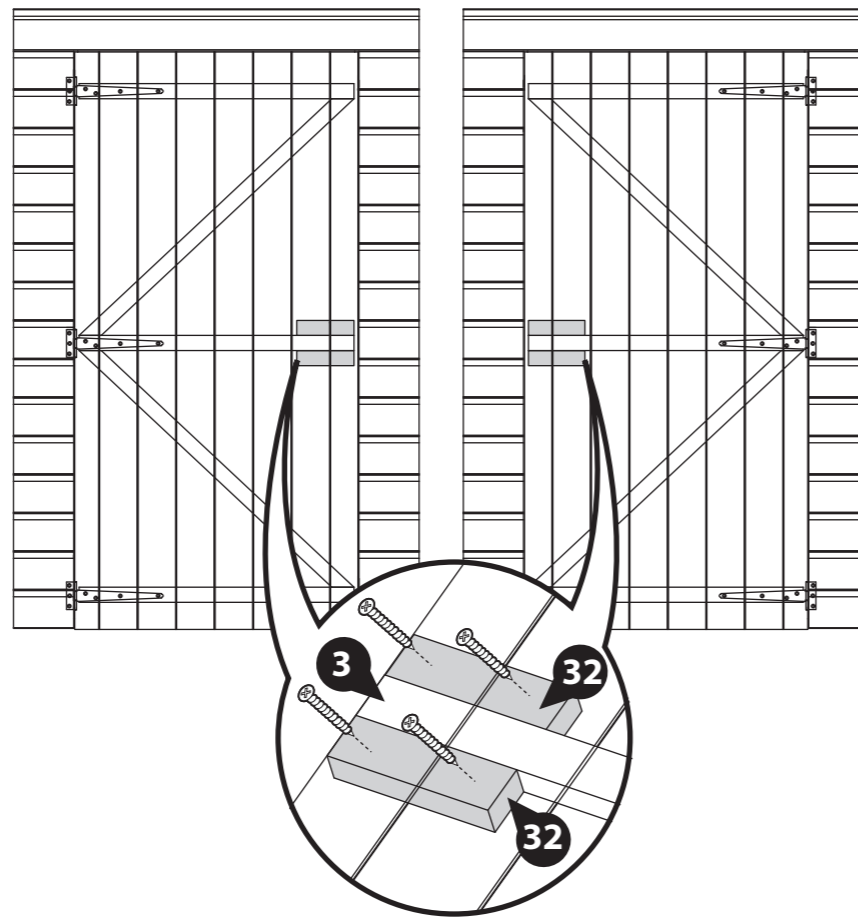

Vertical Handle:

Opens from the Left

Opens from the Right

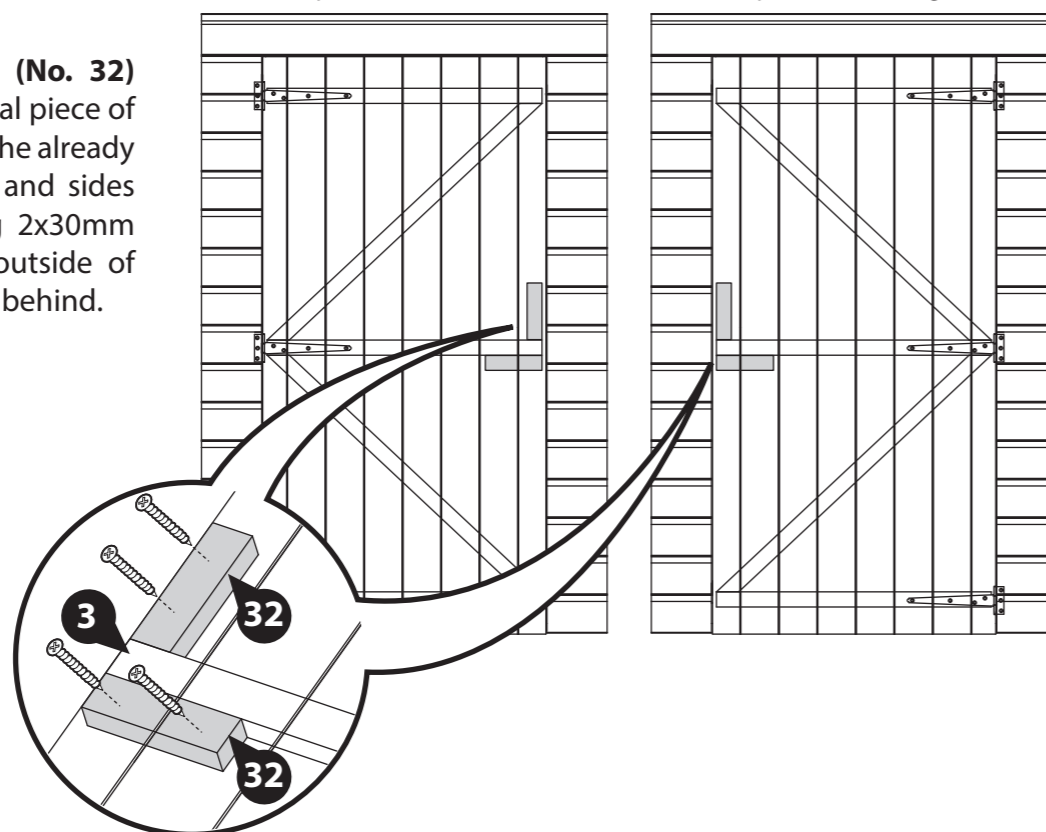

Step 3

Parts needed - No. 28 QTY 1

Locate the Pad Bolt (No. 28) onto the Door (No. 3) ensuring to line it up with the bottom internal door block, and the retainer to the 4ft Door Panel (No. 4b).

Fix in place using 10x30mm screws. Ensure to screw through the cladding into the framing block behind.

10x30mm Screws

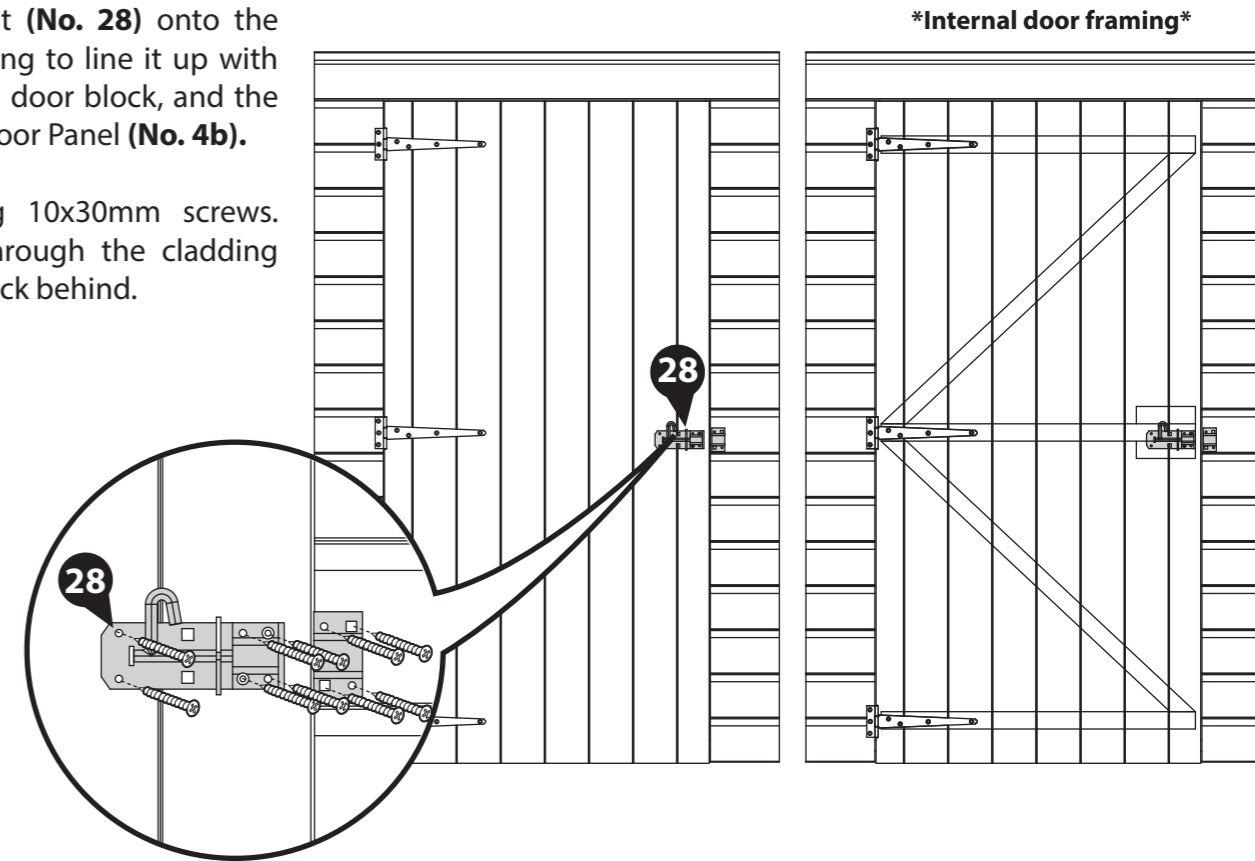

Step 4

Parts needed - No. 27 QTY 2

Position a Turn Button (No. 27) to the top and bottom of the 4ft Door Panel (No. 4b) and fix in place using 1x30mm screw per Turn Button.

Ensure the Turn Buttons rotate to sit across the Door and the Door Panel, as these will help to hold the Door shut.

These Turn Buttons help to keep your doors straight during high and low levels of moisture content in the air.

2x30mm Screws



IMPORTANT: Pre-drill before fixing screws.

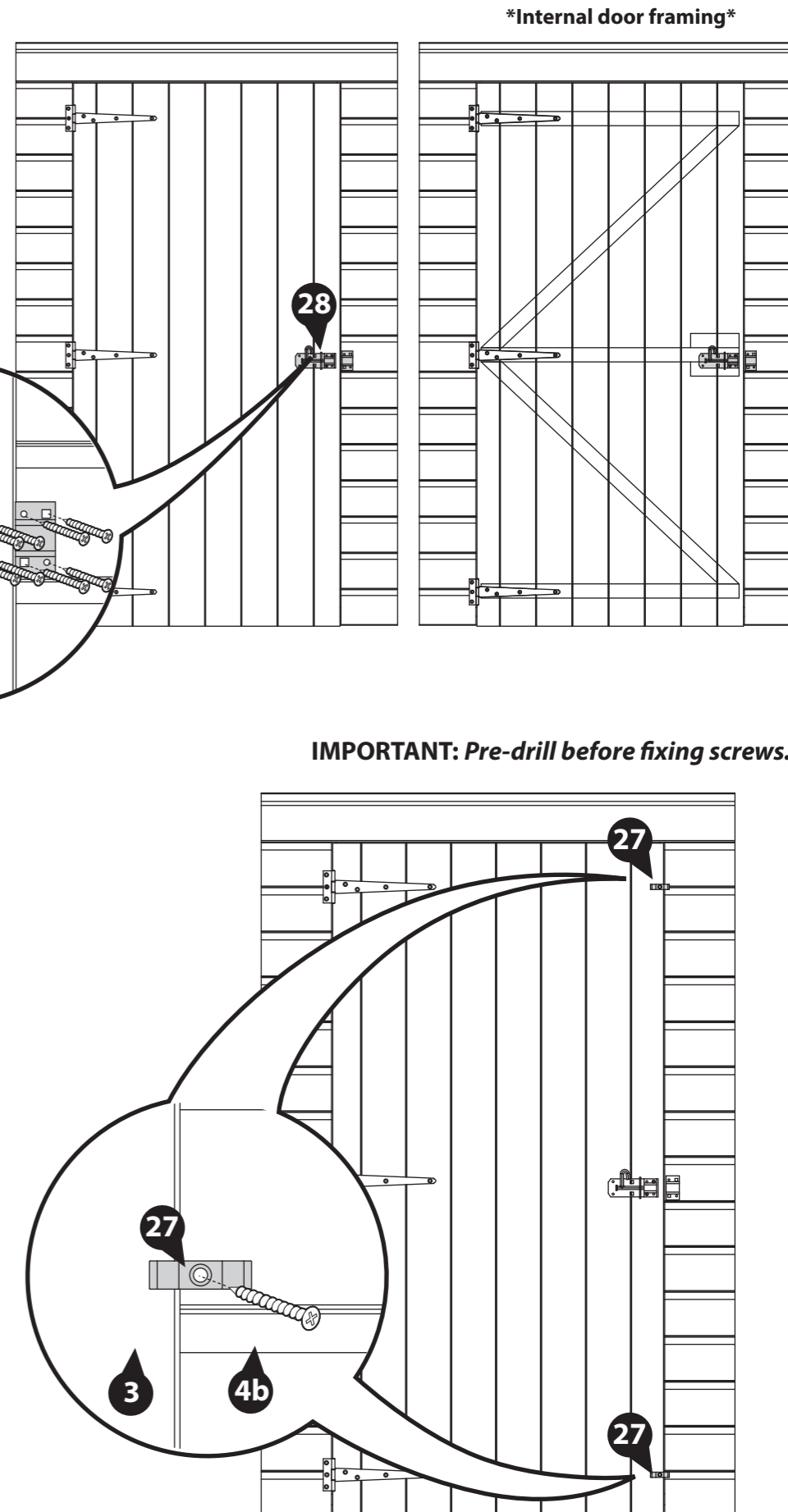

Step 5

Parts needed - No. 29 QTY 1

IMPORTANT: Pre-drill before fixing screws.

Please note: Your Handle can be positioned horizontally or vertically. Please decide which works best before fitting.

Locate the Handle (No. 29) onto the Door (No. 3) so it sits just above the previously fitted Pad Bolt, ensuring to line it up with the internal door blocks.

Secure in place using 4x30mm screws. Ensure to screw through the handle and cladding into the framing block behind.

4x30mm Screws



Pre drill holes
30mm screw

Horizontal Handle:

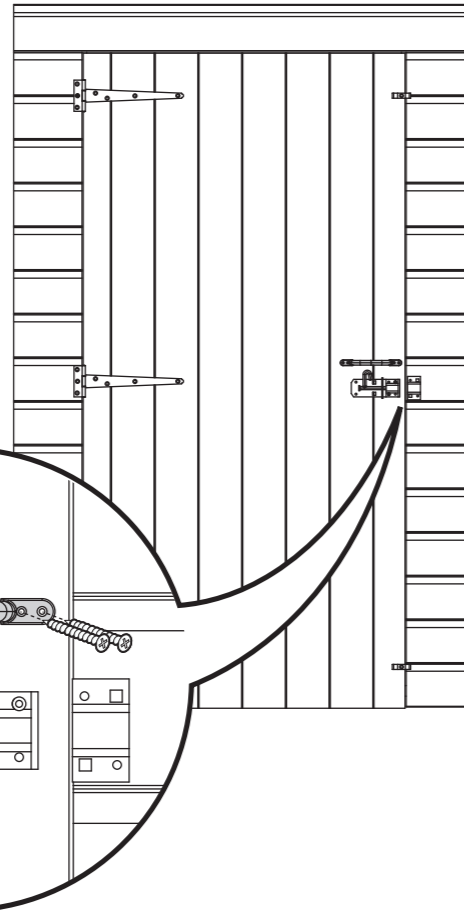

Internal door framing

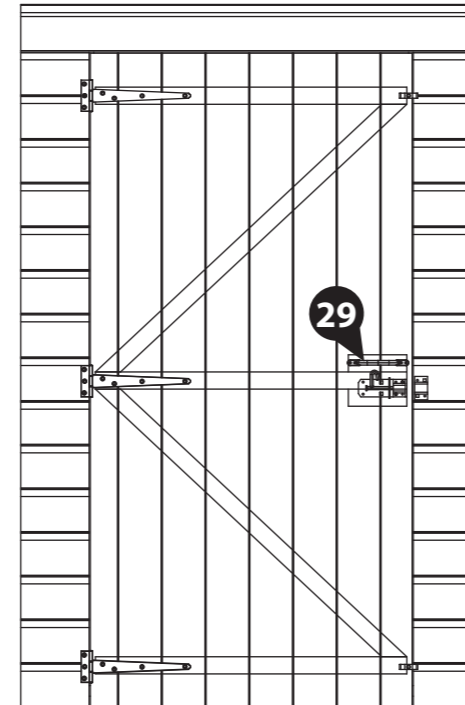

Vertical Handle:

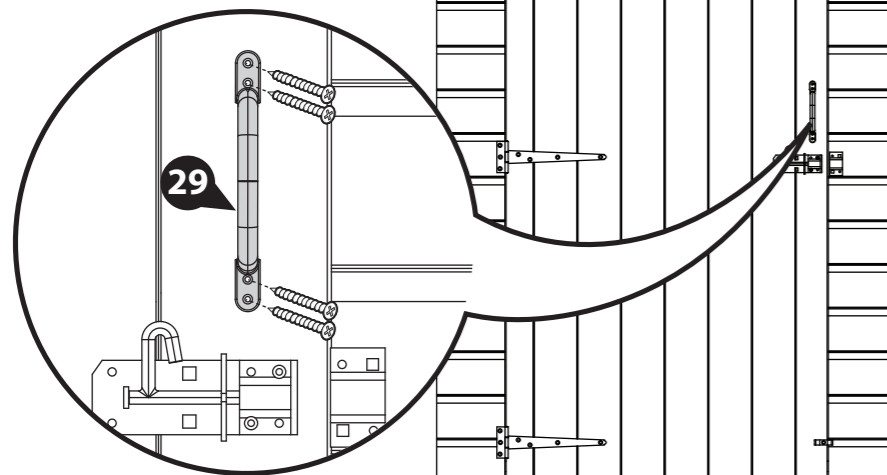

Internal door framing

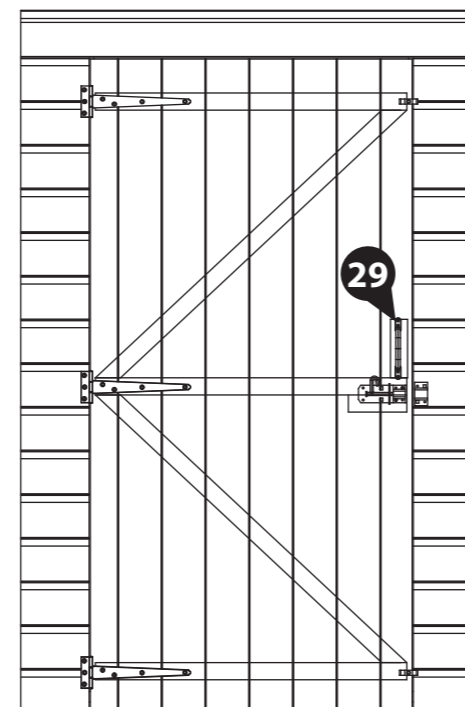

Step 6

Parts needed - No. 1 QTY 4
No. 2 QTY 2

IMPORTANT: Pre-drill before fixing screws.

Place two Floor Panels (No. 1) and one Floor Panel (No. 2) face down onto a firm and level base.

Push the Floor panels together so the bearers are flush and level, as shown.

Secure the Floors together using 6x50mm screws, screwing through the bearers in an alternating pattern.

Repeat this method to secure the remaining Floor Panels (No. 1 & 2) together.

24x50mm Screws



Pre drill holes

50mm screw

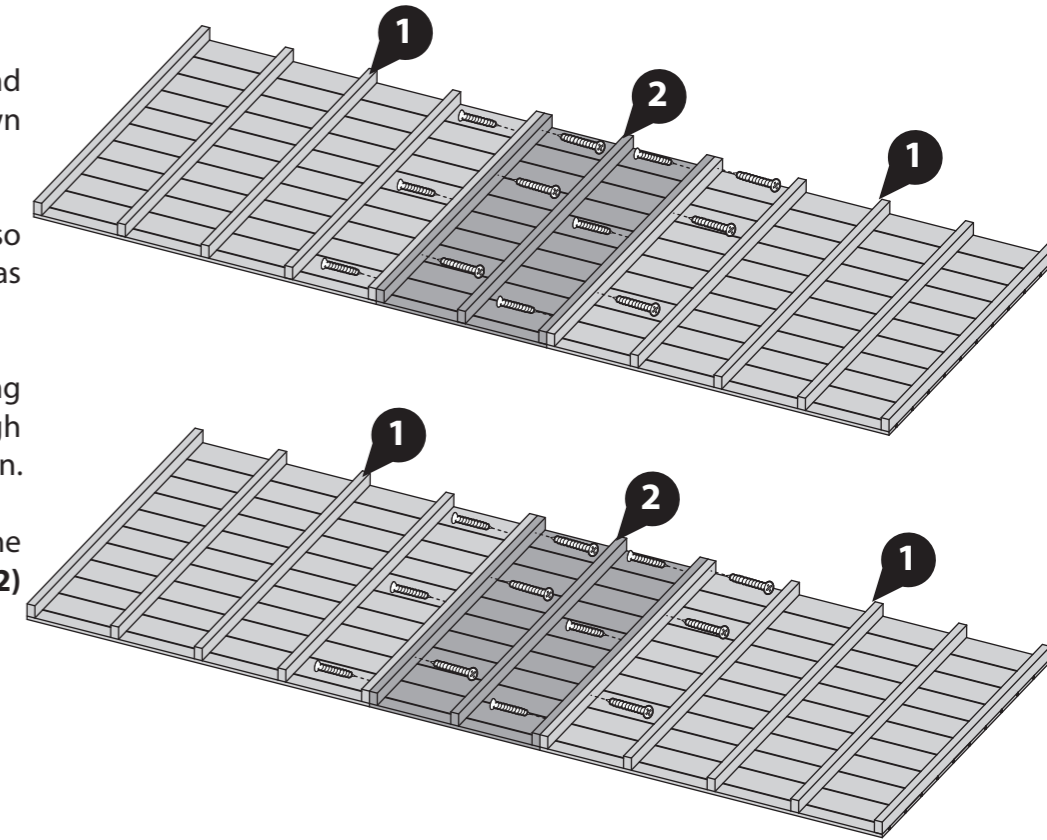

Step 7

Parts needed - No. 1 QTY 4
No. 2 QTY 2
No. 12 QTY 4

Locate one Floor Extension Joist (**No. 12**) onto either end of the assembled Floor Panels. Ensure the joists are flush to Floor Panel framing, as shown.

Secure the joists to the Floor Panels using 5x60mm screws per joist, screwing through the joist into the bearers behind.

20x60mm Screws

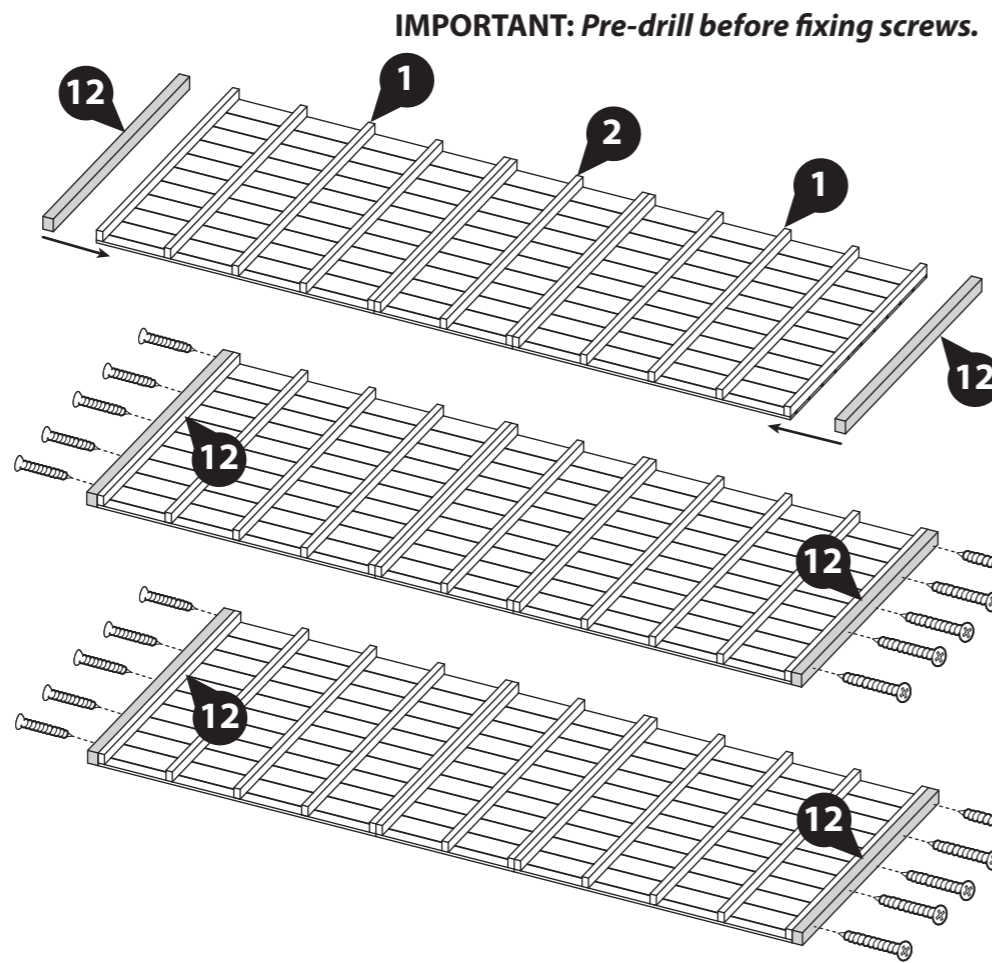
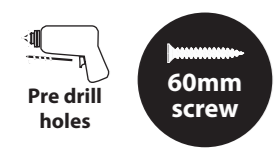

Step 9

Position the two assembled Floors together so the framing ends are flush together, and so the Floor Blocks (**No. 11**) sit under both Floors, as shown.

Secure the Floor to the Floor Blocks using 2x40mm screws per block, screwing through the cladding into the block below.

20x40mm Screws.

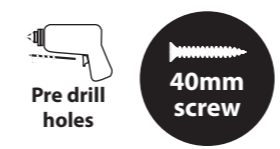

IMPORTANT: Pre-drill before fixing screws.

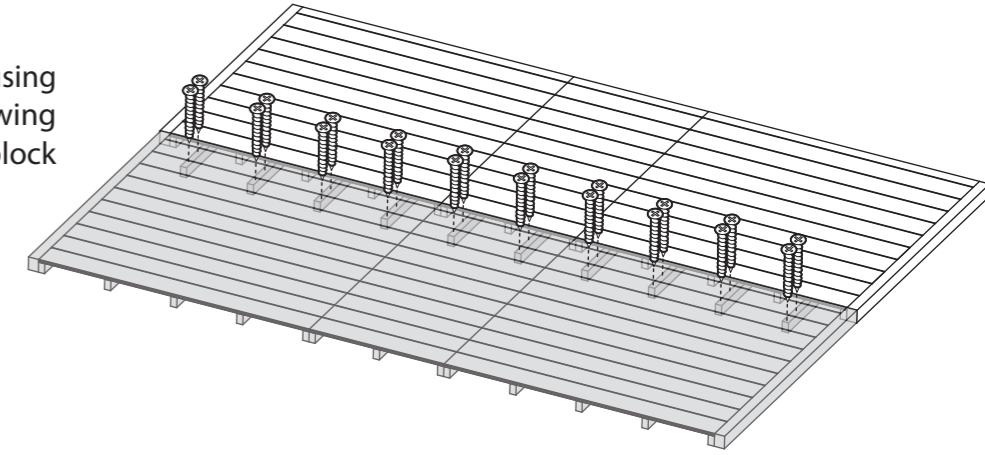

Step 8

Parts needed - No. 11 QTY 10

Once assembled, flip the assembled Floor Panels (**No. 1 & 2**) over so the bearers are flat on your firm and level base. Ensure the base has suitable drainage, free from areas where standing water can collect.

On one set of assembled Floors, position a Floor Block (**No. 11**) centrally between each bearer, ensuring the block sits half under the cladding and half sticking out, as shown.

Fix in place using 2x40mm screws per block, screwing through the cladding into the block below.

20x40mm Screws.

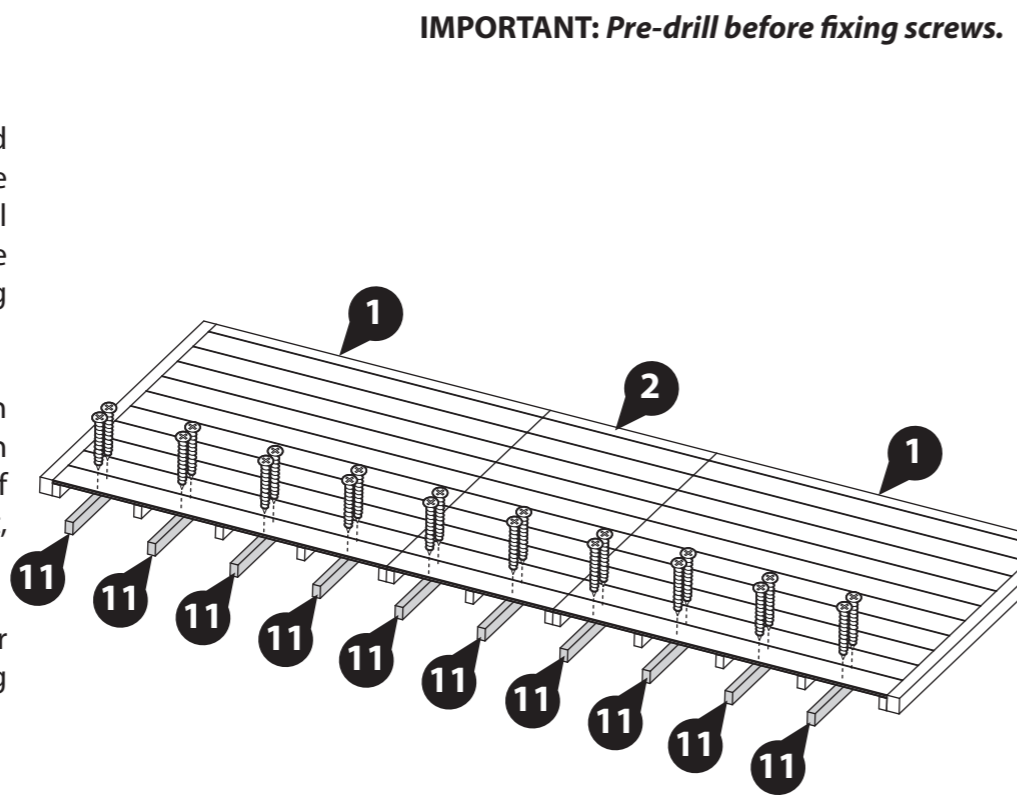
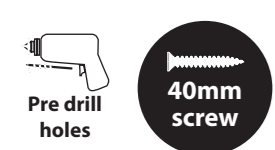

Step 10

Before assembling the shed walls, decide how you want your interchangeable Panels to sit. See Page 4 for some ideas.

It is advised to lay your Panels around the shed Floor in the desired positions, an example is shown below.

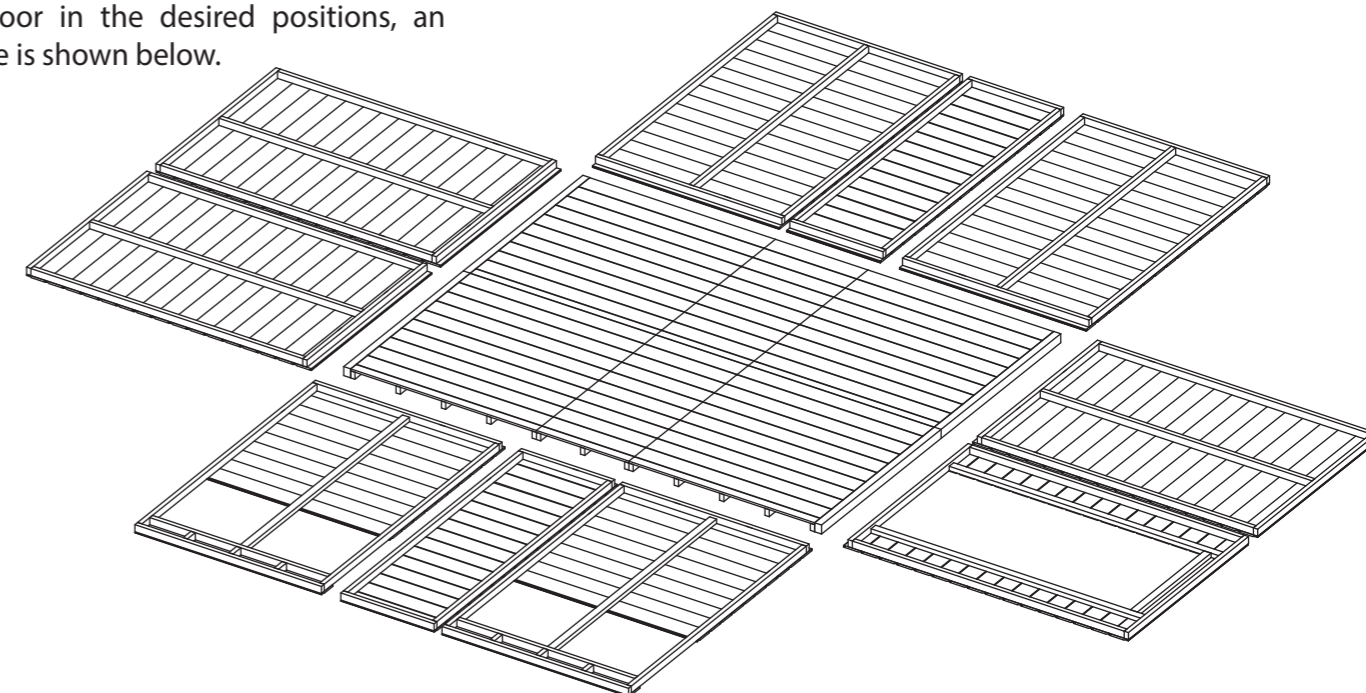

Step 11

Parts needed - No. 4 QTY 2 (4a, 4b OR 4c)

****Please note: The 4ft Panels (No. 4a, 4b and 4c) are all interchangeable and can be positioned in a variety of different configurations. Decide which works best before assembly. See Page 4 for some suggested options.****

Locate a 4ft Panel (No. 4a, 4b, 4c) on top of the Floor panel at one end.

Position another 4ft Panel (No. 4a, 4b, 4c) next to the 4ft Panel on the corner, ensuring the 4ft side Panel sits on the inside of the 4ft end Panel, as shown.

Externally, the Panel's framing should sit flush and the cladding should sit proud, as shown in the diagram.

Secure the Panels together at the corner using 3x50mm screws, screwing through the 4ft side Panel framing into the 4ft end Panel framing behind.

Ensure to position the Panels so there is a small gap between the edge of the Floor and the Panel cladding on all sides.

****Please note: if you have purchased a Panel Brace add-on kit, then you may need to secure the panels together higher up to avoid colliding with the brace and screws.**

****Do not secure the building to the Floor until the Roof has been fitted.**

3x50mm Screws



IMPORTANT: Pre-drill before fixing screws.

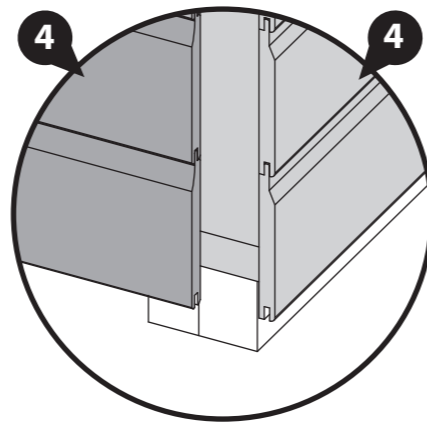
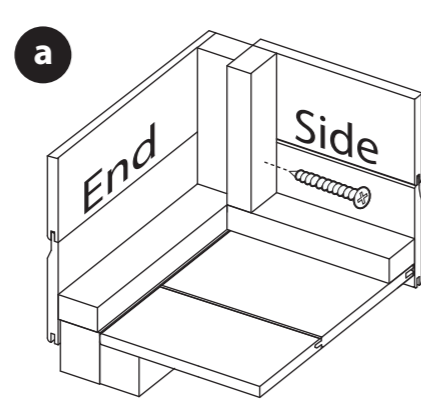
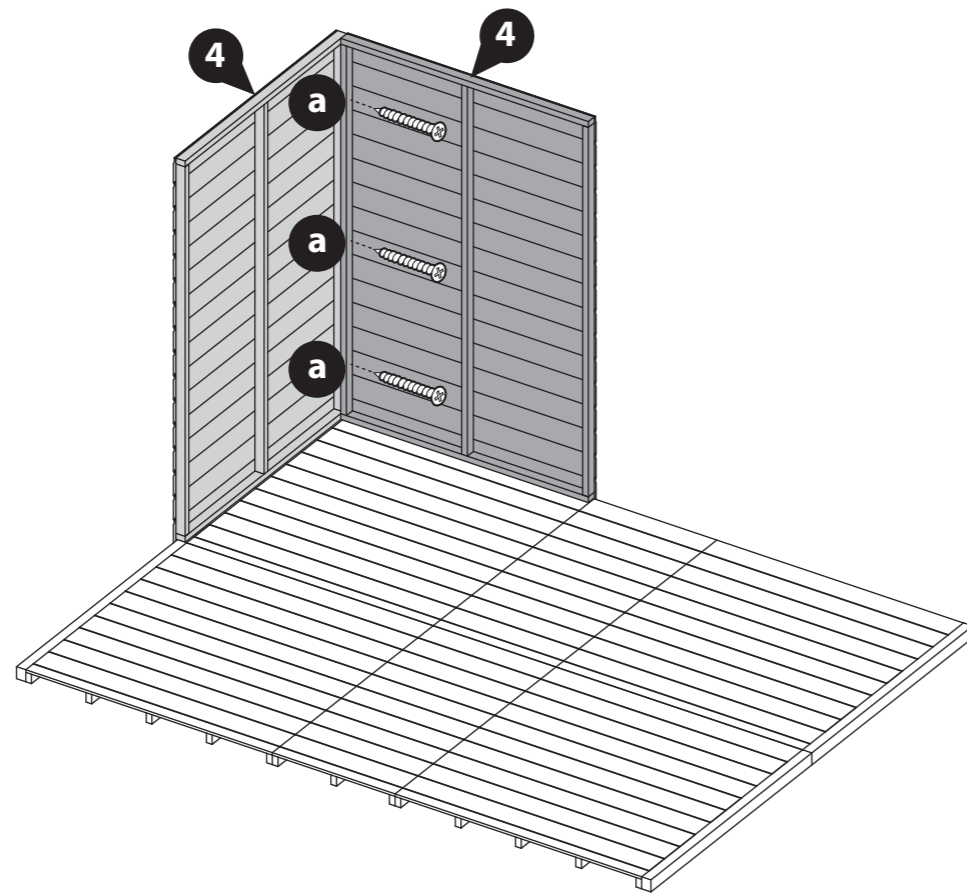

External Corners

Step 12

Parts needed - No. 4 QTY 1 (4a, 4b OR 4c)
No. 5 QTY 1

Locate a 4ft Panel (No. 4a, 4b, 4c) next to the previously placed 4ft Panel (No. 4a, 4b, 4c) on the end. Secure the Panels together using 3x50mm screws, screwing through the Panel framing.

Locate a 2ft Panel (No. 5) next to the previously placed 4ft Panel (No. 4a, 4b, 4c) on the side. Secure the Panels together using 3x50mm screws, screwing through the Panel framing.

Ensure to position the Panels so there is a small gap between the edge of the floor and the Panel cladding on all sides.

****Please note: if you have purchased a Panel Brace add-on kit, then you may need to secure the panels together higher up to avoid colliding with the brace and screws.**

****Do not secure the building to the Floor until the Roof has been fitted.**

6x50mm Screws



IMPORTANT: Pre-drill before fixing screws.

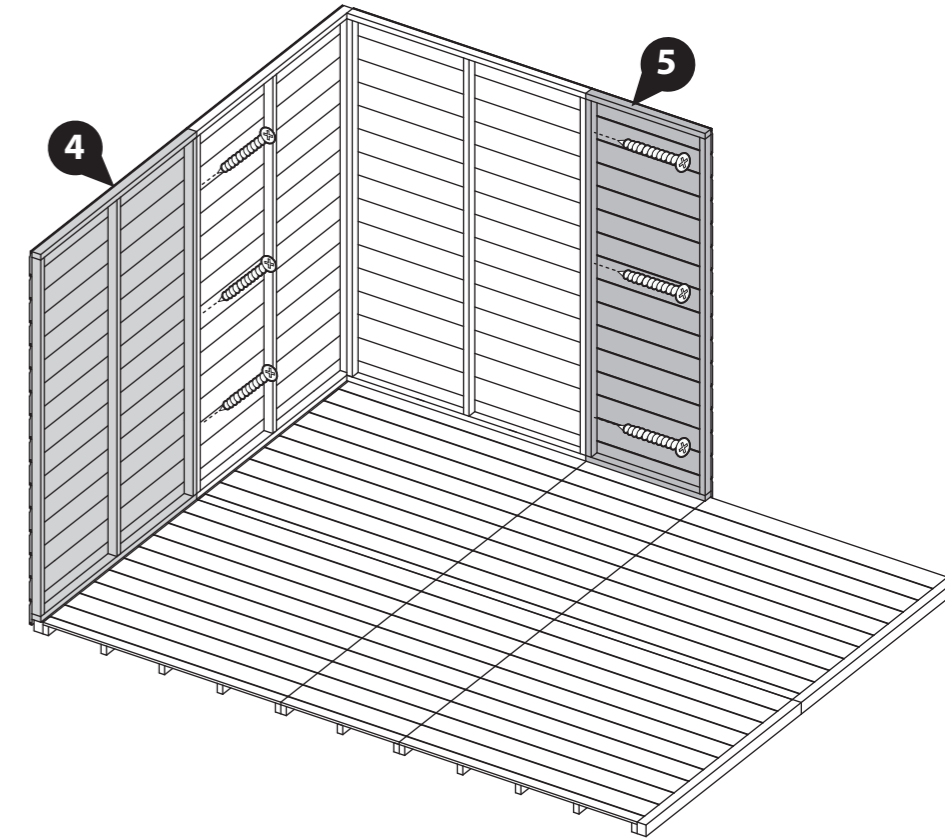

Step 13

Parts needed - No. 4 QTY 1 (4a, 4b OR 4c)

Locate a 4ft Panel (**No. 4a, 4b, 4c**) on the inside of the previously fitted Panel to create the corner, as shown. Externally, the Panel's framing should sit flush and the cladding should sit proud, as shown in the diagram.

Secure the Panels together at the corner using 3x50mm screws, screwing through the 4ft side Panel framing into the 4ft end Panel framing behind.

Ensure to position the Panels so there is a small gap between the edge of the Floor and the Panel cladding on all sides.

****Please note: if you have purchased a Panel Brace add-on kit, then you may need to secure the panels together higher up to avoid colliding with the brace and screws.**

****Do not secure the building to the Floor until the Roof has been fitted.**

3x50mm Screws

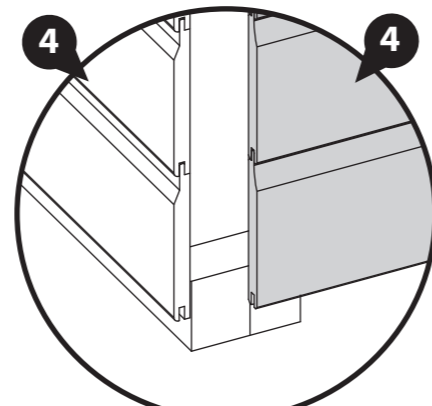
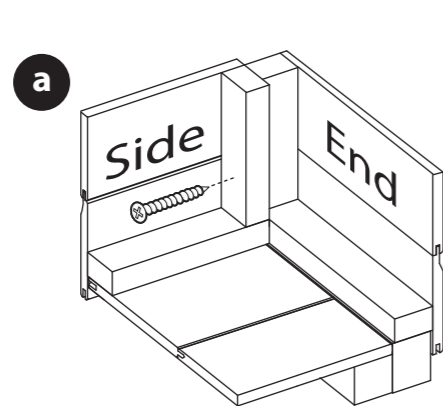

External Corners

IMPORTANT: Pre-drill before fixing screws.

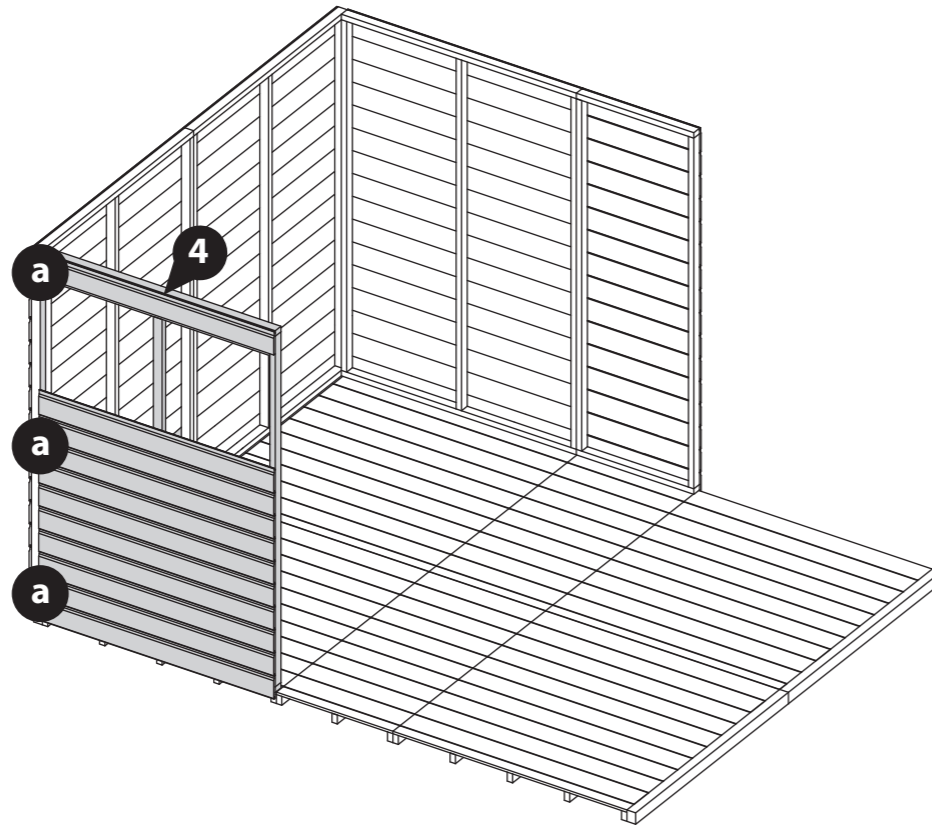

Step 14

**Parts needed - No. 4 QTY 1 (4a, 4b OR 4c)
No. 5 QTY 1**

Locate a 4ft Panel (**No. 4a, 4b, 4c**) next to the 2ft Panel (**No. 5**) along the back, as shown.

Position a 2ft Panel (**No. 5**) next to the 4ft Panel (**No. 4a, 4b, 4c**) placed in the previous step, as shown.

Secure the Panels together using 3x50mm screws, screwing through the Panel framing.

Ensure to position the Panels so there is a small gap between the edge of the Floor and the Panel cladding on all sides.

****Please note: if you have purchased a Panel Brace add-on kit, then you may need to secure the panels together higher up to avoid colliding with the brace and screws.**

****Do not secure the building to the Floor until the Roof has been fitted.**

6x50mm Screws

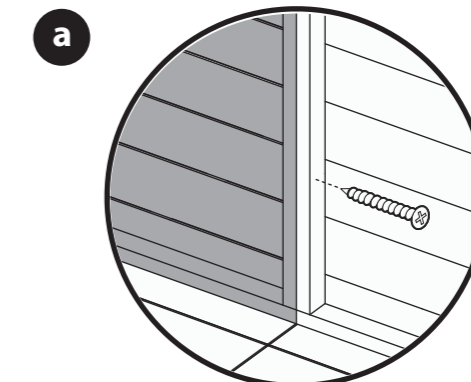

Standard Panels

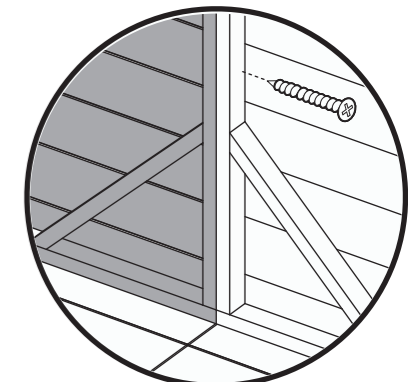

Panel brace kit ONLY

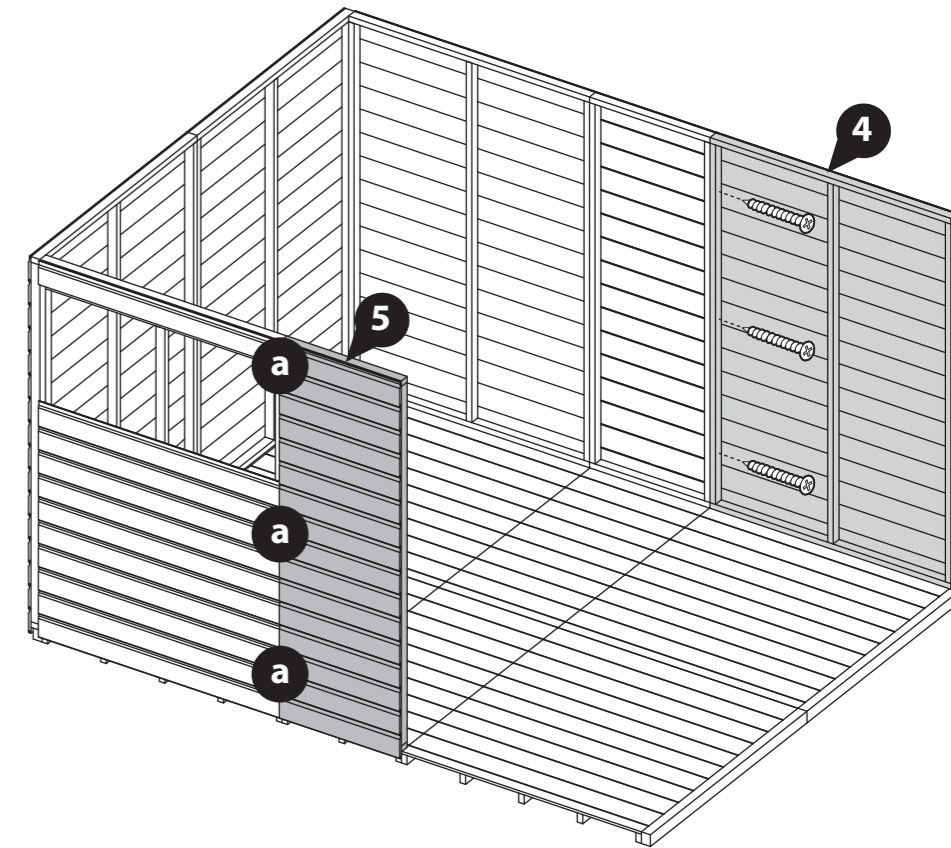

IMPORTANT: Pre-drill before fixing screws.

Step 15
Parts needed - No. 4 QTY 1 (4a, 4b OR 4c)

Locate a 4ft Panel (No. 4a, 4b, 4c) next to the 2ft Panel (No. 5) along the front as shown.

Fix the Panels together using 3x50mm screws, screwing through the Panel framing.

Ensure to position the Panels so there is a small gap between the edge of the Floor and the Panel cladding on all sides.

****Please note: if you have purchased a Panel Brace add-on kit, then you may need to secure the panels together higher up to avoid colliding with the brace and screws.**

****Do not secure the building to the Floor until the Roof has been fitted.**

3x50mm Screws

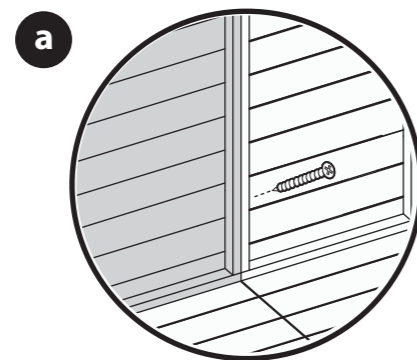
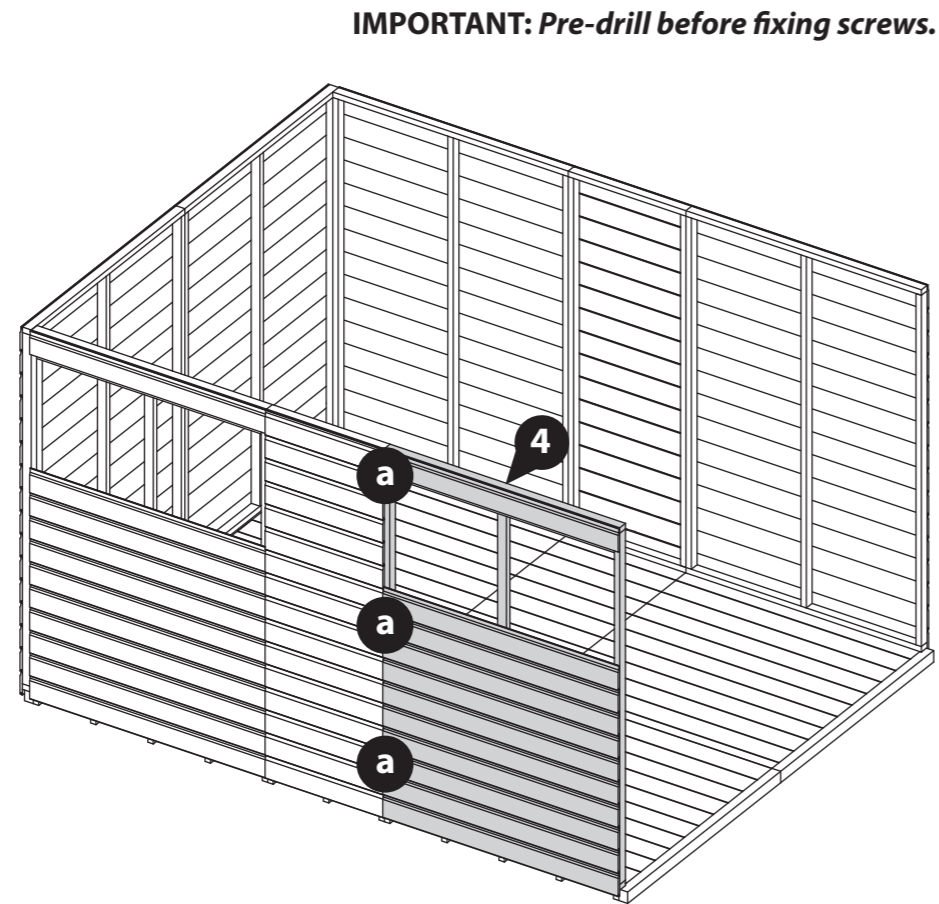

Standard Panels



Panel brace kit ONLY

Step 16
Parts needed - No. 4 QTY 2 (4a, 4b OR 4c)

Locate the remaining 4ft Panels (No. 4a, 4b, 4c) on top of the Floor at the end, ensuring they sit on the outside of the previously placed Panels, as shown.

Externally, the Panels framing should sit flush and the cladding should sit proud, as shown in the diagram.

Fix the Panels together using 3x50mm screws, screwing through the Panel framing.

Secure the Panels to the previously placed Panels using 3x50mm screws per corner, screwing through the adjacent Panel framing into the Panel framing behind.

Position the Panels so there is a small gap of equal distance between the edge of the Floor and the Panel cladding on all sides. This allows for the buildings natural movement over time.

****Please note: if you have purchased a Panel Brace add-on kit, then you may need to secure the panels together higher up to avoid colliding with the brace and screws.**

****Do not secure the building to the Floor until the Roof has been fitted.**

9x50mm Screws

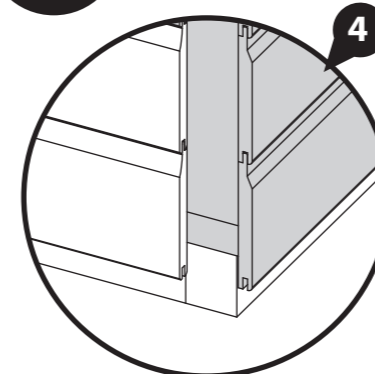
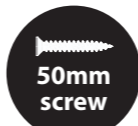

External Corners

IMPORTANT: Pre-drill before fixing screws.

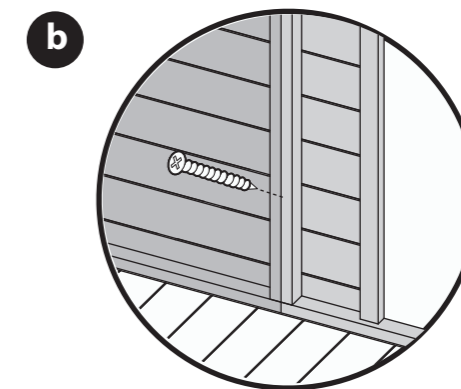
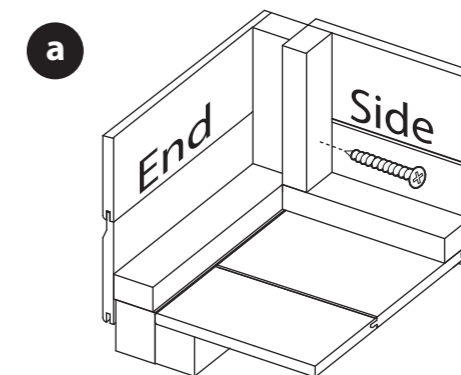
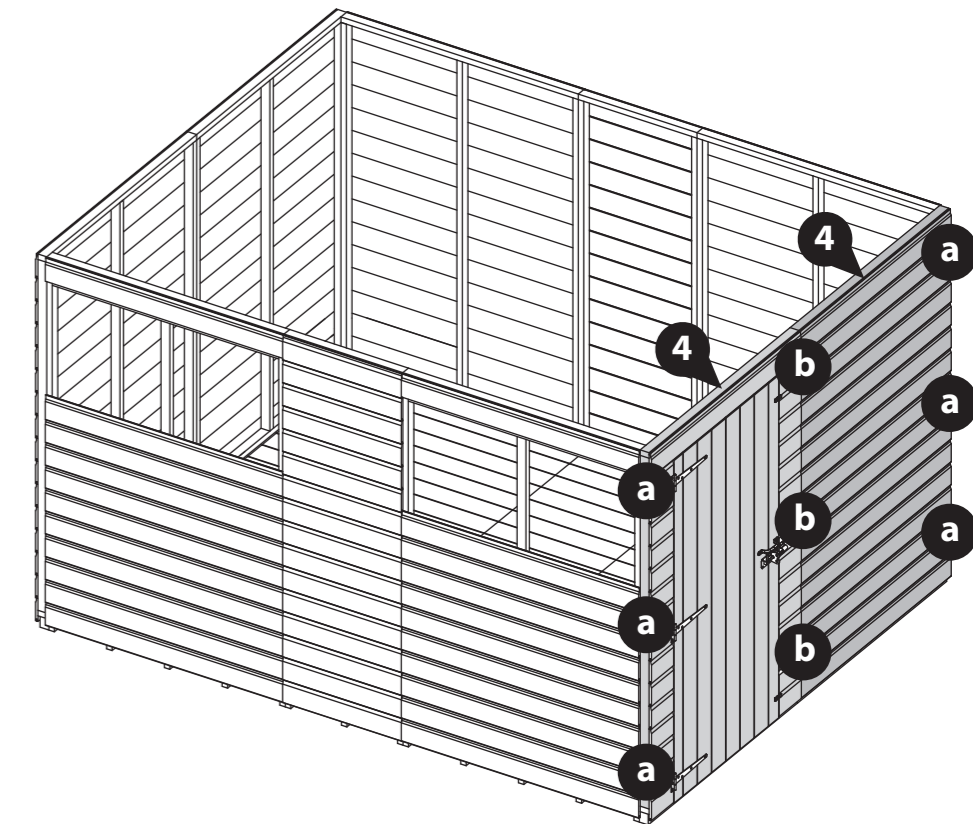

Standard Panels



Panel brace kit ONLY

Step 17

**Parts needed - No. 6 QTY 2
No. 7 QTY 2**

a Locate one Left Gable Top (**No. 7**) on top of a Panel at one end. Ensure that the Gable cladding slots into the top cladding on the Panel below and that it aligns with the central join of the Panels, as shown.

Secure in place using 4x50mm, screwing up through the Panel framing into the Gable.

b Locate one Right Gable Top (**No. 6**) next to the previously positioned Left Gable Top (**No. 7**). Ensure the Right Gable is flush to the Left Gable and aligned to the Panel below.

Secure in place using 4x50mm screws, screwing up through the Panel framing into the gable.

Fix the two Gable Tops together using 3x50mm screws, screwing through the central framing in an alternating pattern.

c Repeat the above method (A-B) to locate and secure the remaining two Gable Tops (**No. 6 & 7**) onto the opposite end.

22x50mm Screws



Pre drill holes
50mm screw

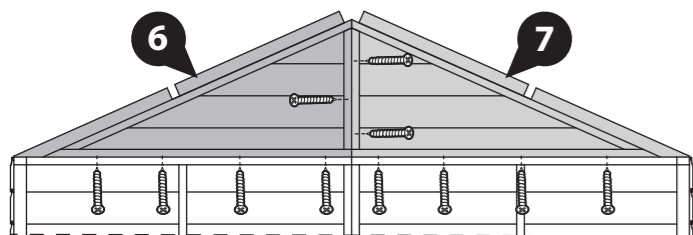

IMPORTANT: Pre-drill before fixing screws.

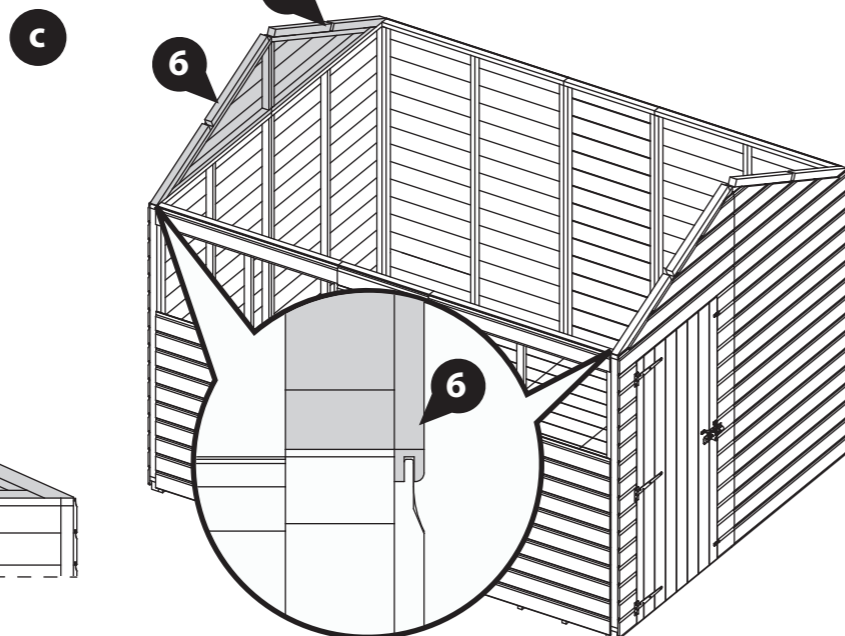
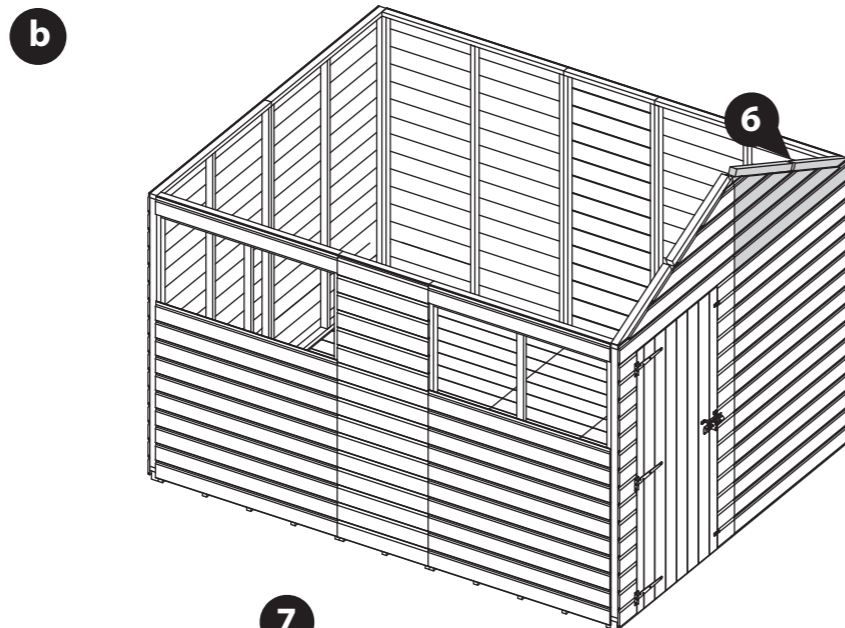
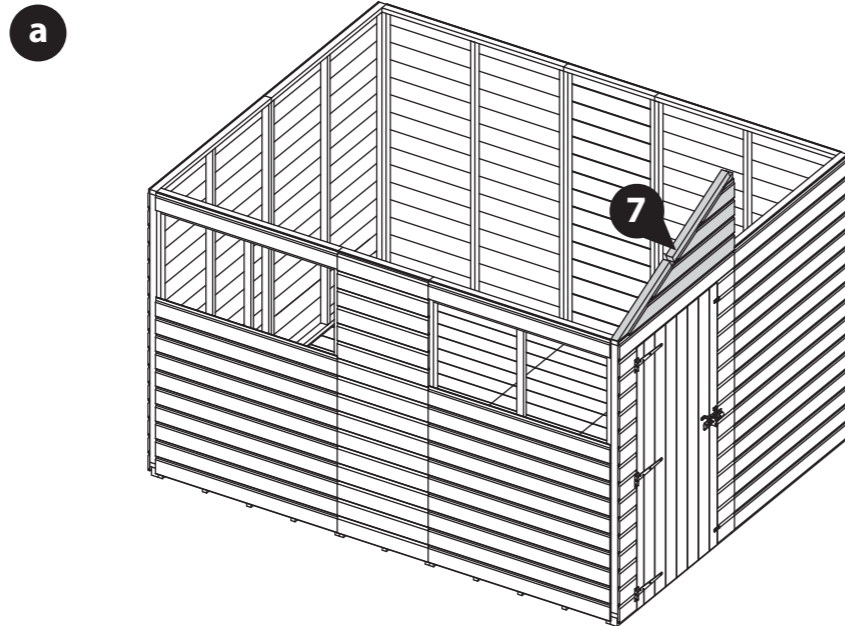

Step 18

**Parts needed - No. 13 QTY 2
No. 26 QTY 1
No. 30 QTY 2**

Position the two Ridge Bars (**No. 13**) so the ends are flush together and locate the U-channel (**No. 26**) centrally across the join, as shown.

Secure the U-channel in place using 10x30mm screws.

Locate one Corner Brace (**No. 30**) to either end of the assembled Ridge bar, ensuring they are flush with the ends of the ridge bar, as shown.

Secure in place using 2x30mm screws per brace.

14x30mm Screws



Pre drill holes
30mm screw

Step 19

Align the assembled Ridge Bar (**No. 13**) with the central framing on the Gables, ensuring the top and sides are flush.

(If you have not yet assembled your Ridge Bar, please refer to Step 18).

Secure the Corner Braces (**No. 30**) to the central uprights using 2x30mm screws per brace.

4x30mm Screws



Pre drill holes
30mm screw

IMPORTANT: Pre-drill before fixing screws.

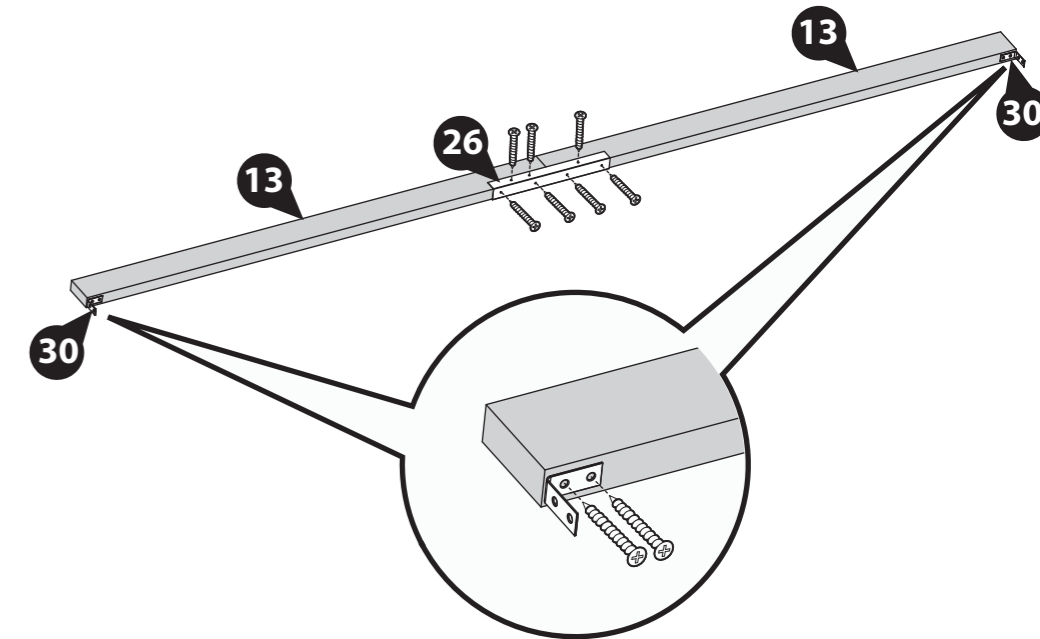

IMPORTANT: Pre-drill before fixing screws.

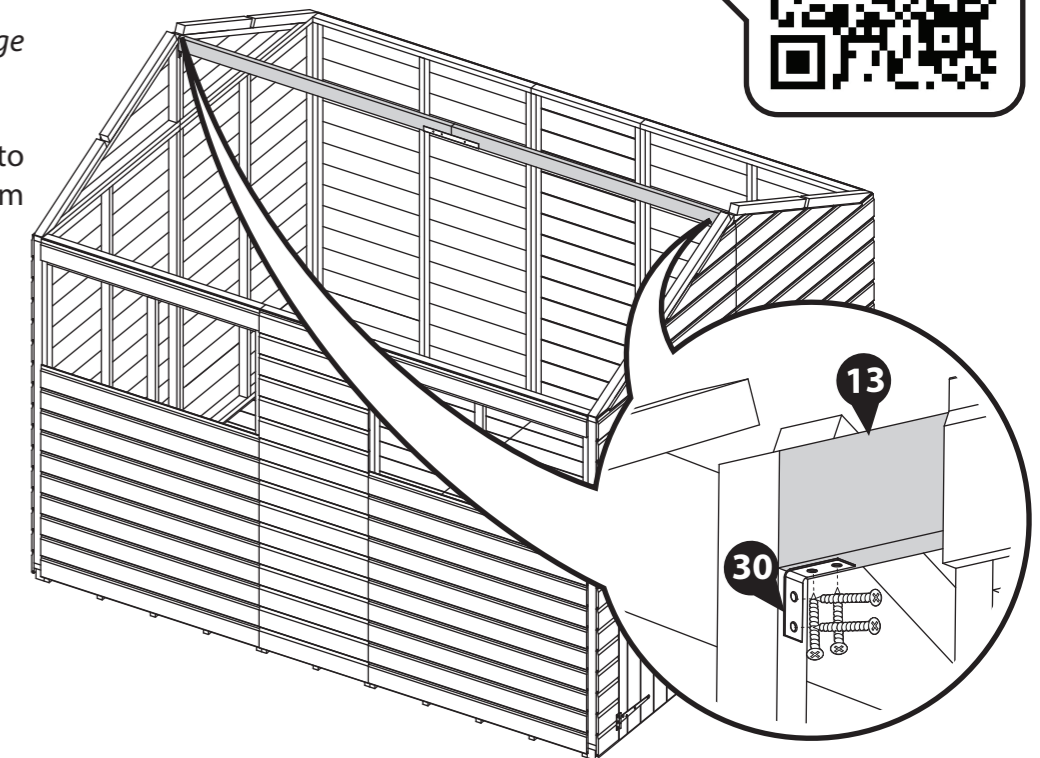

IMPORTANT: Pre-drill before fixing screws.

Step 20

Parts needed - No. 8 QTY 2

No. 9 QTY 4

No. 10 QTY 2

No. 26 QTY 6

a At one end of the building, position a Large 2ft Roof Panel (**No. 9**) onto the Gable Tops, ensuring the roof panel framing sits firmly within the notches on the Gable Top and on top of the Ridge Bar (**No. 13**).

****Make sure that you have the Roof Panels the correct way round with the recess at the top of the apex, as shown in the diagram.****

b Place one 4ft Roof Panel (**No. 8**) next to the Large 2ft Roof Panel (**No. 9**), ensuring the framing is flush, level and that the Panels sit firmly on the Ridge Bar.

Secure the Panels together by screwing through the top framing at an angle using 1x50mm screw.

Position a U-Channel (**No. 26**) centrally across the middle framing of the Panels, where the two join, as shown. Secure in place using 10x30mm screws.

c Position a Small 2ft Roof Panel (**No. 10**) next to the 4ft Roof Panel (**No. 8**), ensuring the framing is flush, level and that the Panels sit firmly on the Ridge Bar.

Secure the Panels together by screwing through the top framing at an angle using 1x50mm screw.

Position a U-Channel (**No. 26**) centrally across the middle framing of the Panels, where the two join, as shown. Secure in place using 10x30mm screws.

d Position another Large 2ft Roof Panel (**No. 9**) next to the Small 2ft Roof Panel (**No. 10**), ensuring the Roof Panel framing sits firmly within the notches on the Gable Top and on top of the Ridge Bar.

Secure the Panels together by screwing through the top framing at an angle using 1x50mm screw.

Position a U-Channel (**No. 26**) centrally across the middle framing of the Panels, where the two join, as shown. Secure in place using 10x30mm screws.

Once four Roof Panels are in place on one side, ensure they are positioned centrally to the building. The Roofs should slightly overhang the Gables at either end of the building.

e Repeat the above steps (A-D) to locate the remaining Roof Panels onto the other side of the building, ensuring they align with the previously fitted Panels. Secure the Panels together by screwing through the underside of the framing into the adjacent Panel.

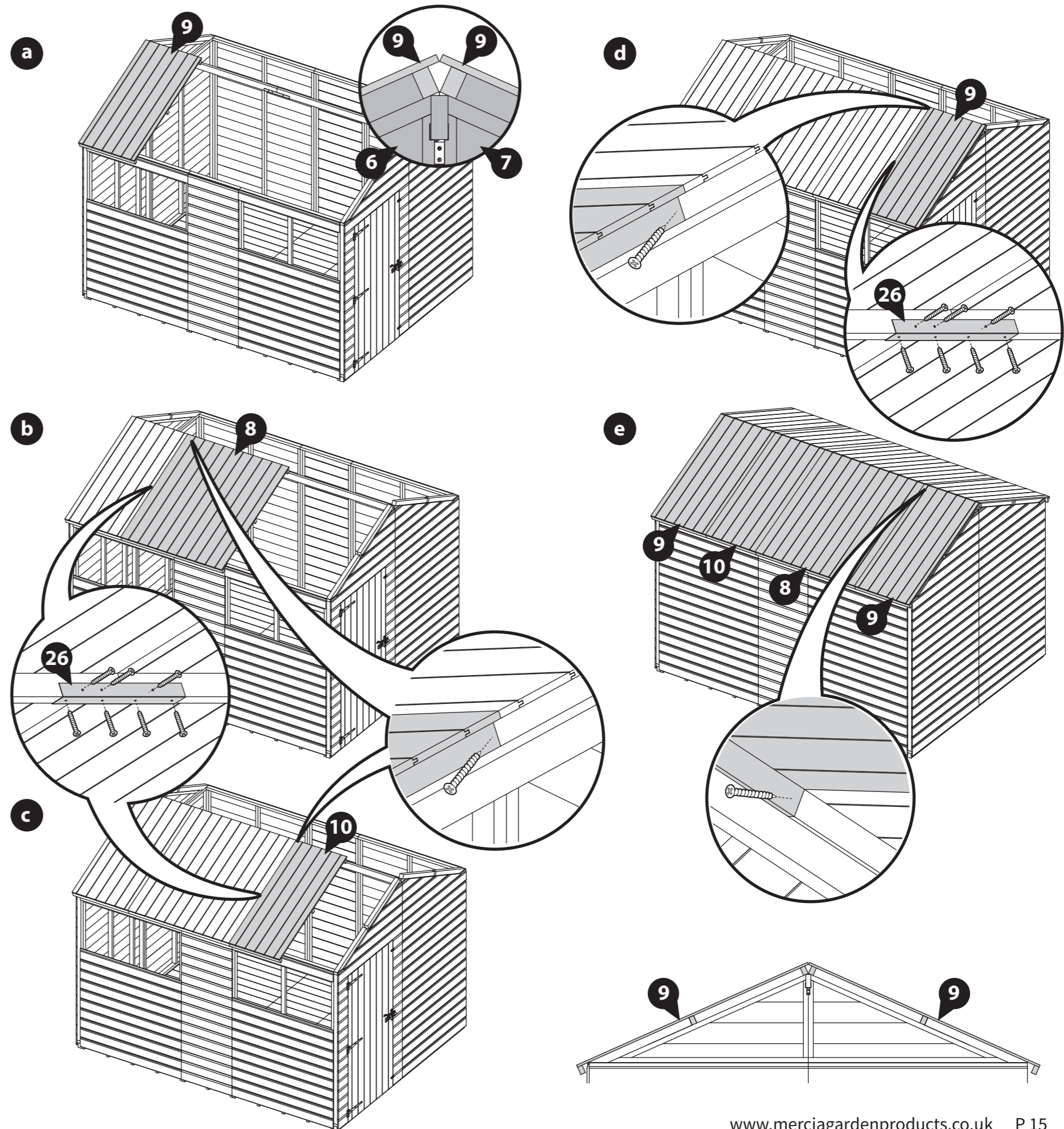

6x50mm Screws
60x30mm Screws



Step 21

Once the Roof Panels are in place and positioned centrally to the building, they can be fixed in place.

Ensure to check that your Roof Panels are aligned. The framing should be sat in the Gable Tops, align with the opposite Roof and be flush at the ends.

Internally, screw up at an angle through the Ridge Bar (No. 13) into the roof panels (No. 8, 9 & 10) framing above using 1x70mm screws per 2ft Roof Panel and 2x70mm screws per 4ft Roof Panel.

Ensure to stagger the screws to avoid collision.

It is essential that the Ridge Bar (No. 13) and Roof Panels (No. 8, 9 & 10) framing pull together when secured. You may require another person pushing the Ridge Bar (No. 13) up from below to achieve this.

10x70mm Screws

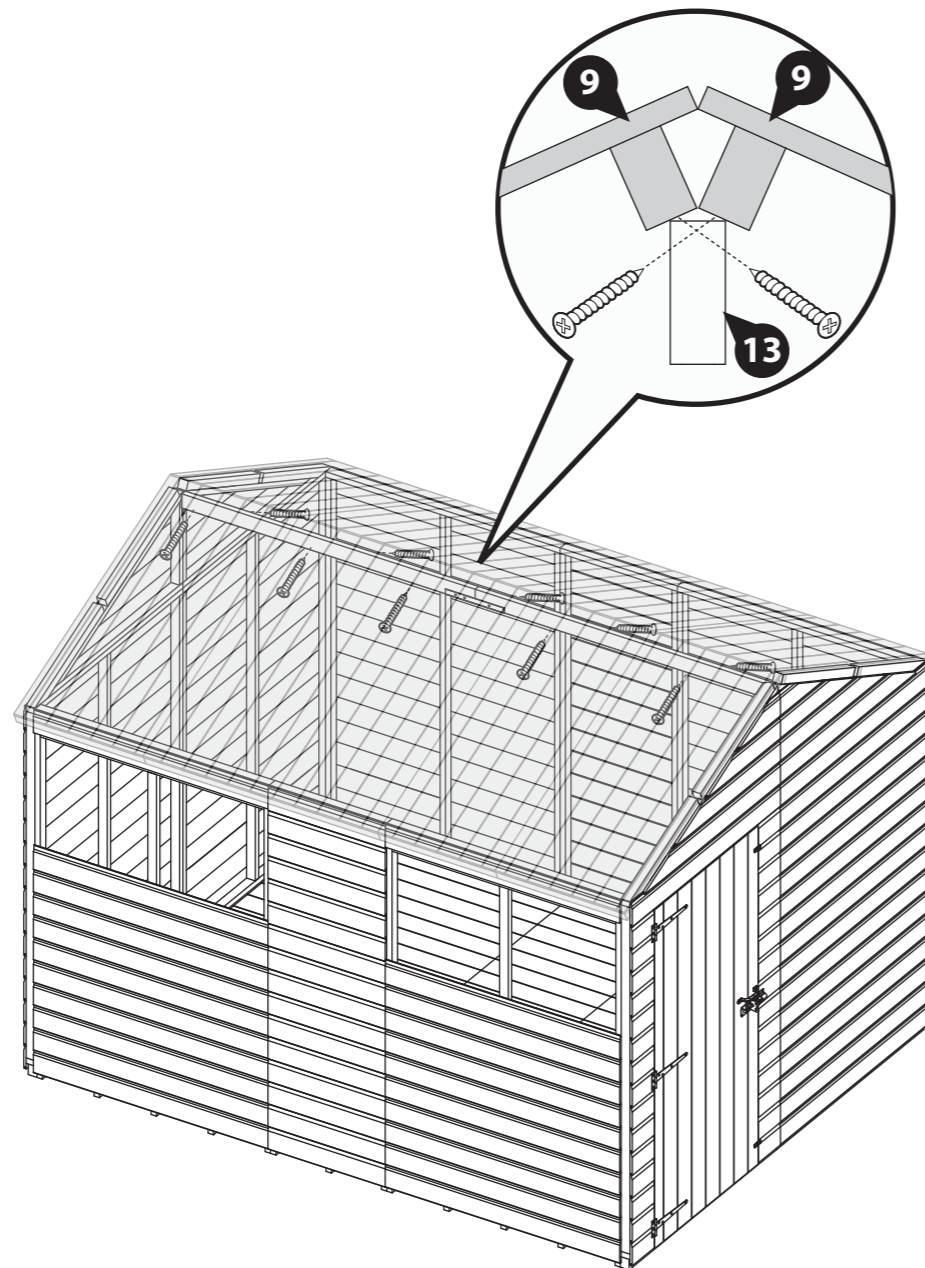

IMPORTANT: Pre-drill before fixing screws.

Step 22

Parts needed - No. 15 QTY 2

On either side of the Ridge bar, position a Truss Frame (No. 15), underneath the Roof Panels (No. 8) central to the building.

Tip: To get the Truss central, use a tape measure to find the middle of the walls, mark with a pencil or tape and align the truss to the mark.

Ensure the block on top of the Truss Frame (No. 15) sits flush to the underside of the roof panel cladding, flush to the top framing and slot between the Roof Panel framing, as shown.

Fix the Truss Frame (No. 15) in place using 5x30mm screws per frame, screwing down through the Roof Panels (No. 8) into the Truss Frame (No. 15) from the outside of the building.

It is essential that the Truss Frame (No. 15) and Roof Panels (No. 8) pull together when secured. You may require another person pushing the Truss Frame (No. 15) up from below to achieve this.

10x30mm Screws



IMPORTANT: Pre-drill before fixing screws.

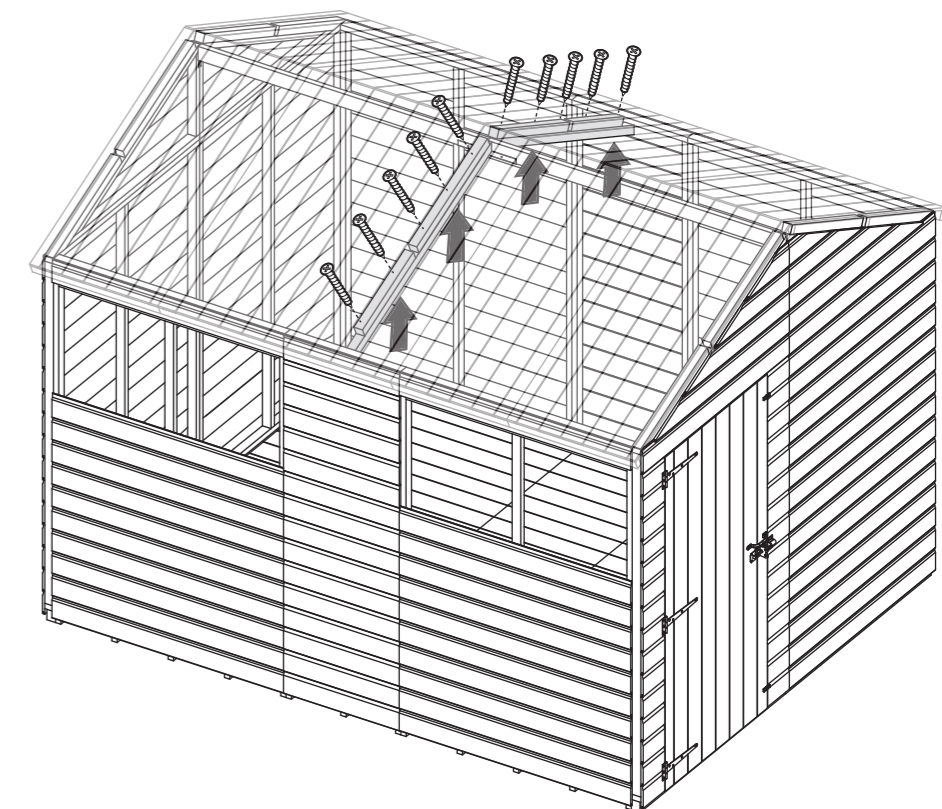
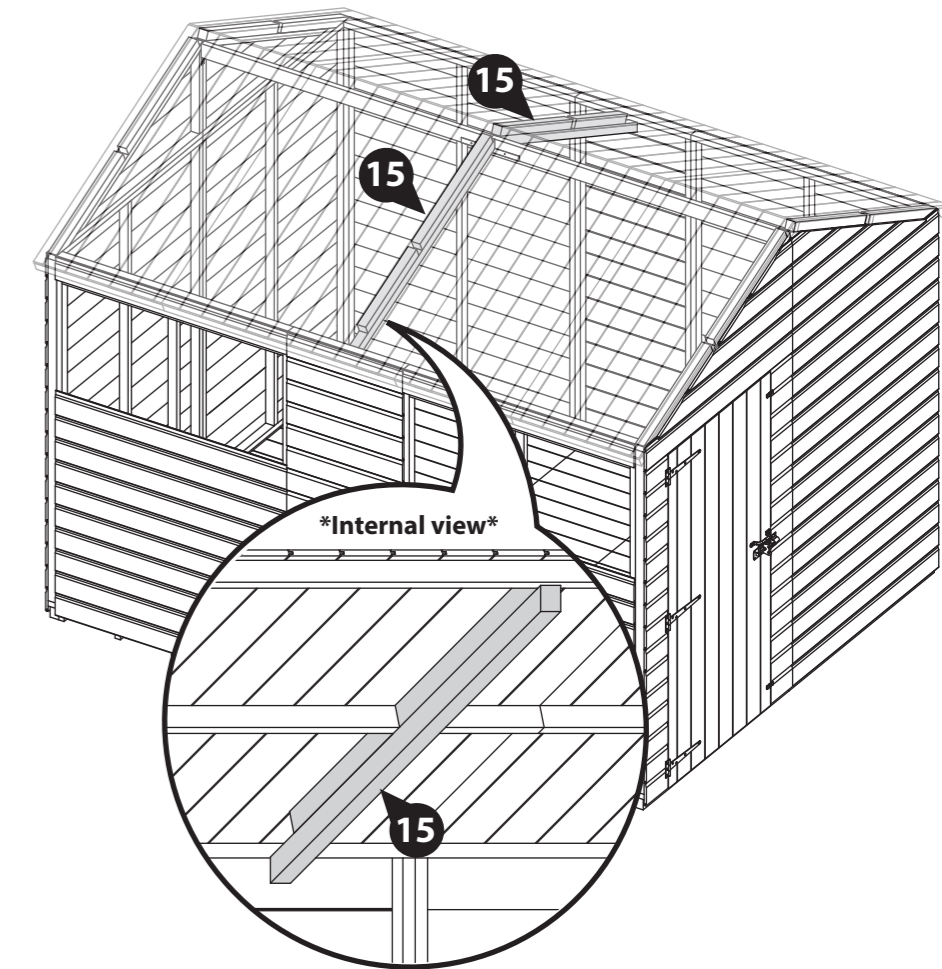

Step 23
Parts needed - No. 17 QTY 2

Please note: You have been supplied with two Truss Support Blocks (No. 17) however you may only need to use one.

Depending on how you have arranged your 4ft Panels, you may need to use the Truss Support Blocks (No. 17) to help secure your truss.

Check if there is a piece of upright framing below the previously positioned Truss Frame (No. 15). If not, then you will need to use the Truss Support Blocks (No. 17).

To locate a Truss Support Block (No. 17), position the block flush to the internal Panel cladding and the underside of the top framing. Ensure it is in line with the Truss Frame (No. 15), as shown.

Secure the block in place using 2x40mm screws, screwing through the outside cladding into the block inside.

Repeat on the opposite side of the building if necessary.

4x40mm Screws

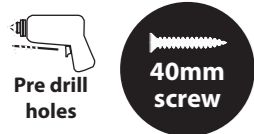

IMPORTANT: Pre-drill before fixing screws.

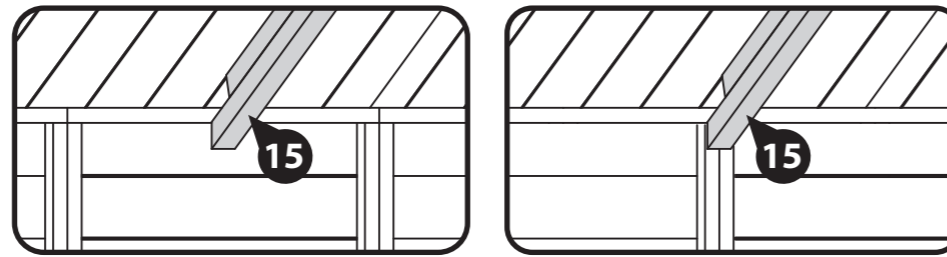

Truss Support Block is required.

Truss Support Block is NOT required.

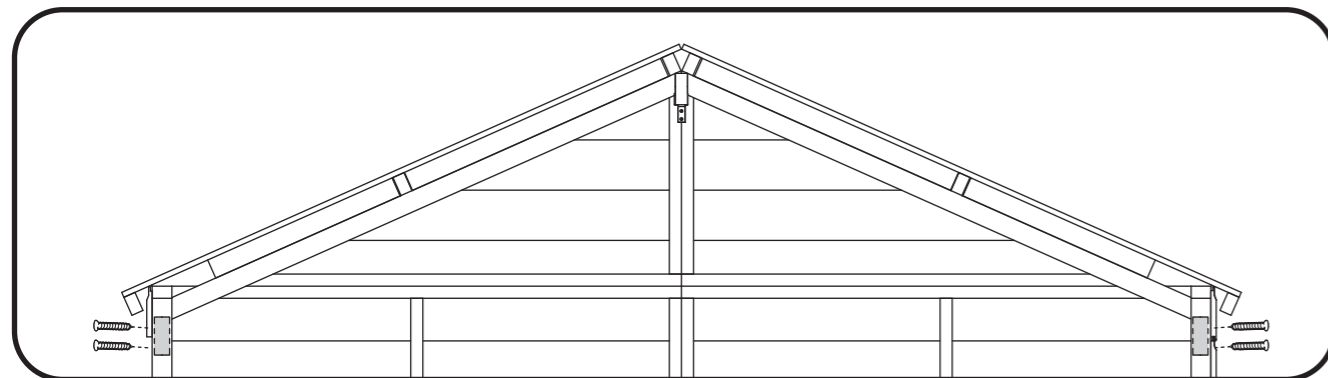
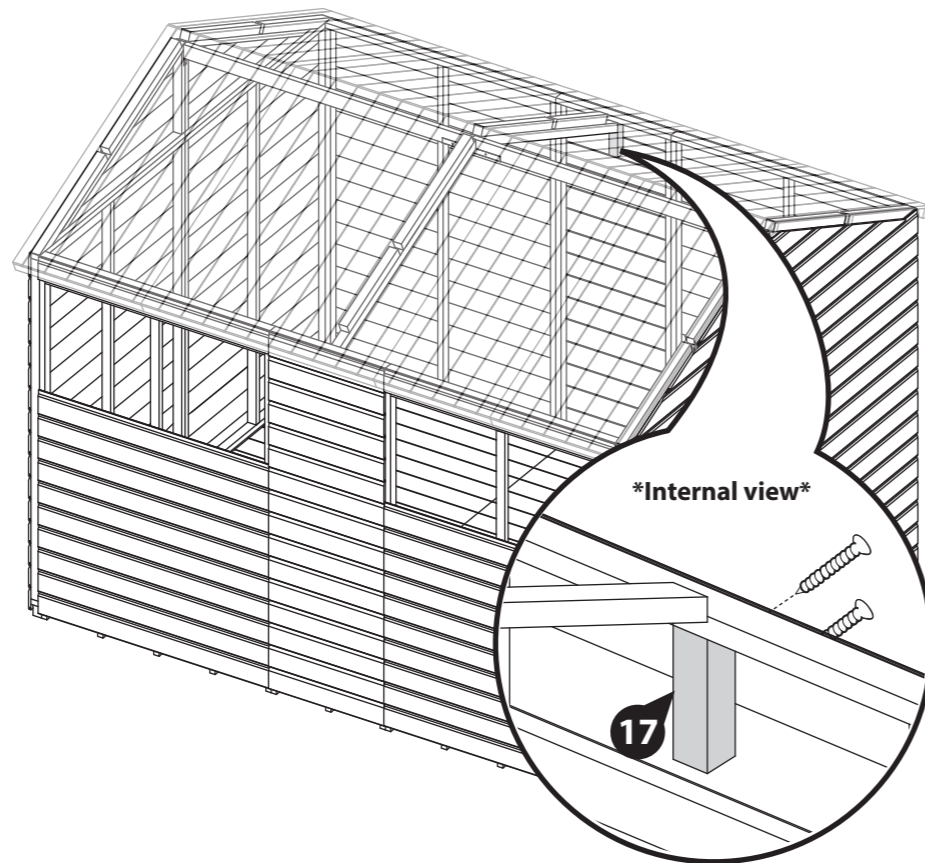

Step 24
Parts needed - No. 14 QTY 2

Place the Truss Block (No. 14) up to the Truss Frame (No. 15) so the angled cut edge is facing upwards, flush to the Truss Frame (No. 15).

Ensure the block is also flush to the framing (Support Block or Panel upright) behind.

Fix in place using 2x50mm screws through the block into the framing behind. Ensure to stagger screws to avoid collision.

Repeat on the opposite side of the building.

4x50mm Screws



IMPORTANT: Pre-drill before fixing screws.

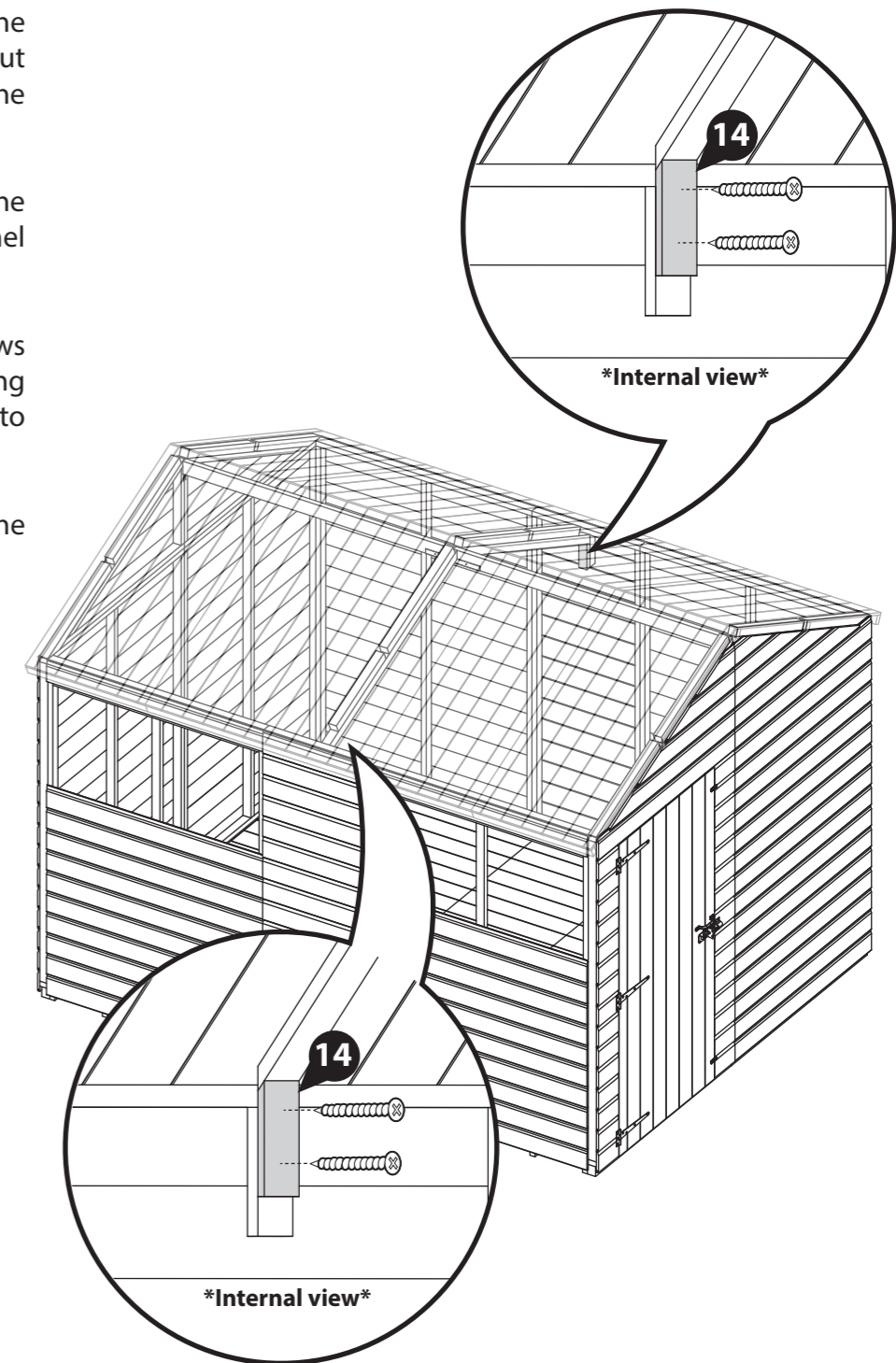

Step 25
Parts needed - No. 16 QTY 2

Position one Truss Support (No. 16) onto either side of the Truss Frames (No. 15) ensuring the angled ends of the Truss Support are flush with the Truss Frame framing, as shown.

Make sure that the Truss Support is positioned under where the Roof Panel framing sits in the Truss frame, as shown.

Once in position fix the Truss Supports (No. 16) in place using 4x40mm screws per support, ensuring to stagger screws to avoid collision.

8x40mm Screws

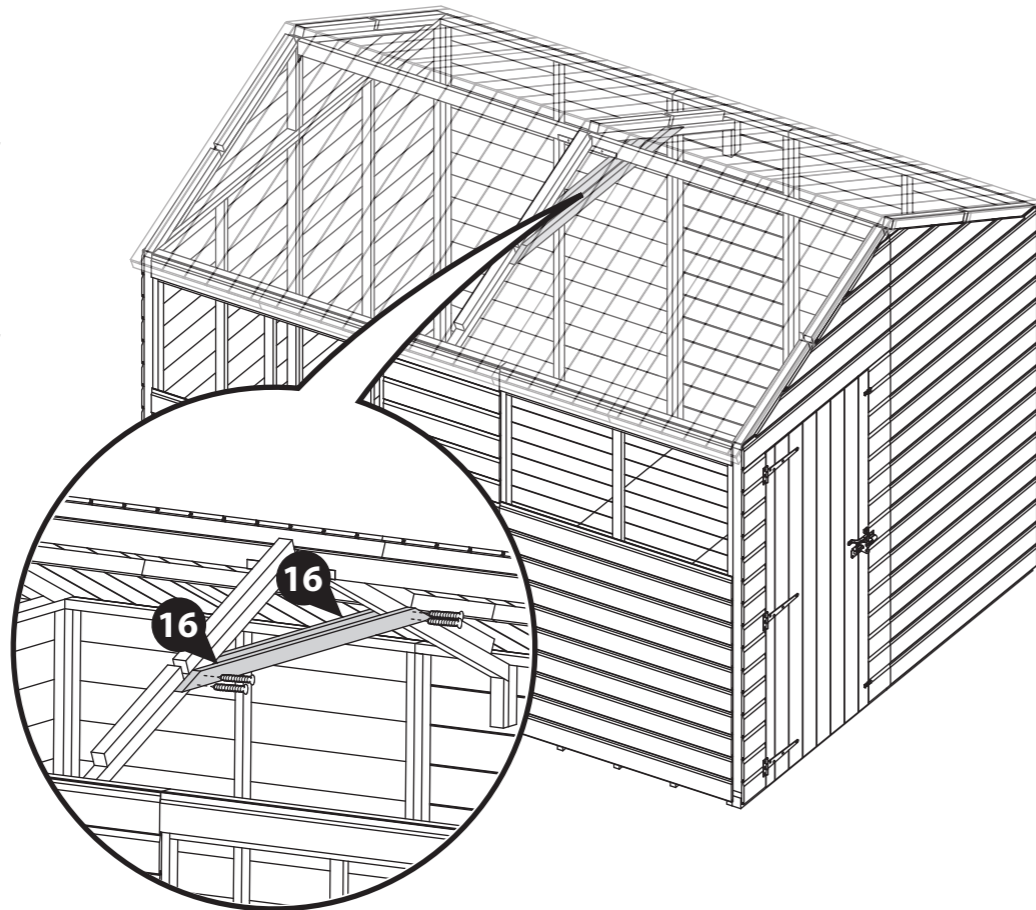

IMPORTANT: Pre-drill before fixing screws.

Step 27

Once the roof is fixed, secure the panels to the Floor using 50mm screws, screwing down through the Panel framing into the Floor bearers below.

****Please note: If you have purchased a panel brace kit, when fixing near an angled brace, you may need to screw through the Panel framing at an angle to ensure they are in line with the Floor bearers.**

26x50mm Screws

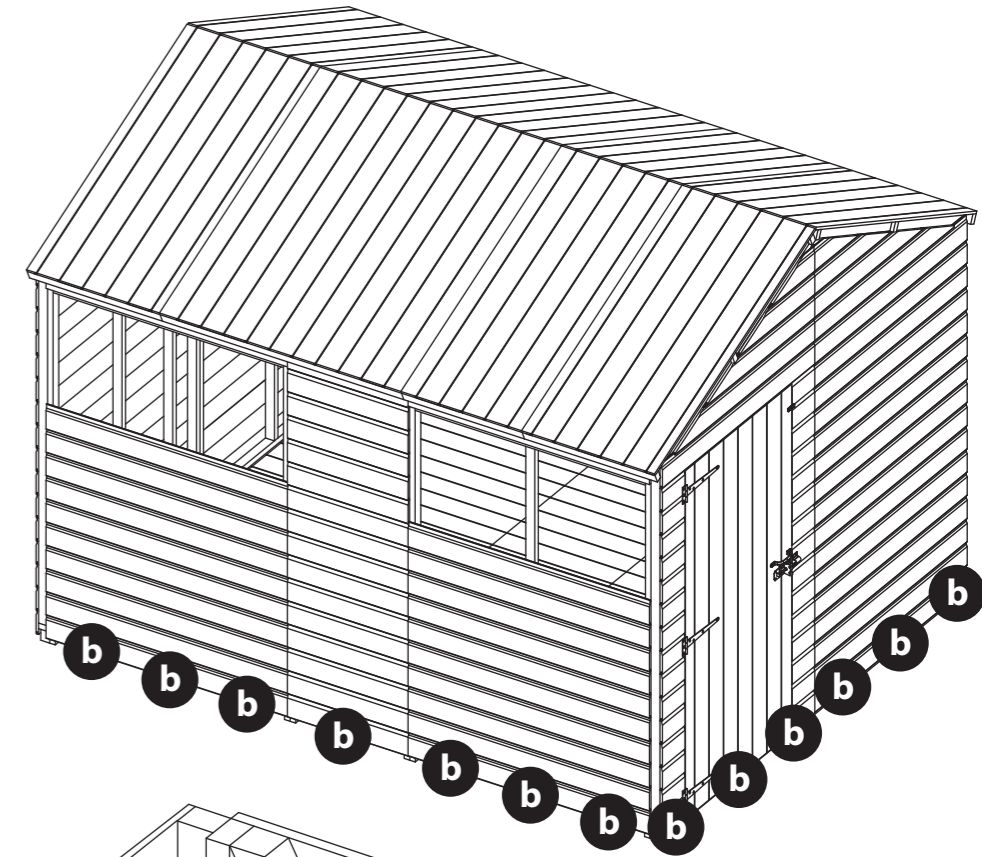

IMPORTANT: Pre-drill before fixing screws.

Step 26

Make sure the building is square by measuring from corner to corner and comparing the measurements. If the measurements are equal, the building is square, if not, adjustments may be required.

Once square, secure the Roofs (No. 8, 9 & 10) in place using 40mm screws by screwing down through the cladding into the Panel framing below.

Ensure there is no more than 300mm between each screw and that each screw is countersunk to avoid interference when felting.

28x40mm Screws

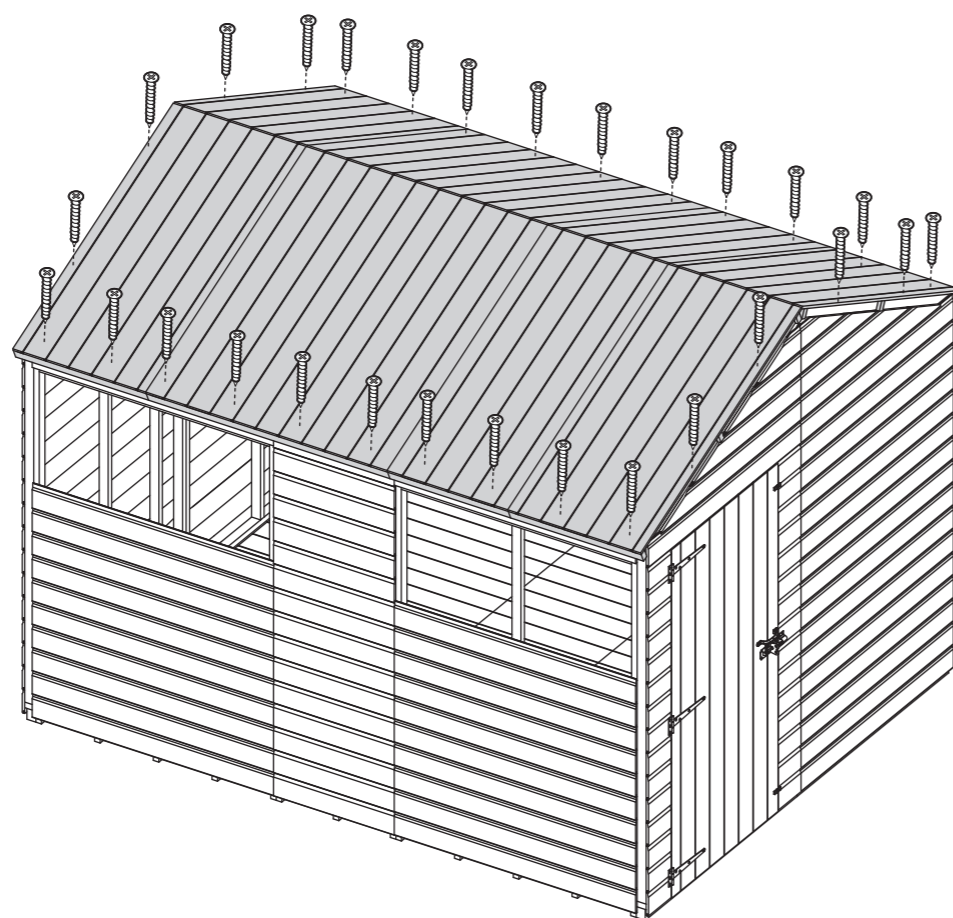

IMPORTANT: Pre-drill before fixing screws.

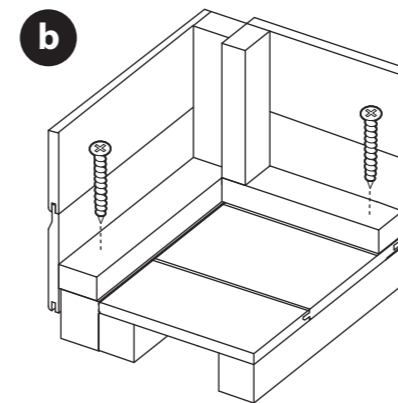

Standard Panels

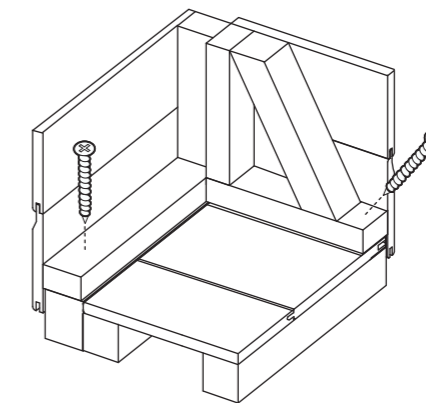

Panel brace kit ONLY

Step 28

- Parts needed - No. 18 QTY 2
- No. 19 QTY 10
- No. 20 QTY 2
- No. 21 QTY 4

- a** Inside the 4ft Window Panel (No. 4a) opening, locate one Window Strip (No. 19) to either side of the outer window framing exposed in the window gap, as shown. Secure in place using 3x30mm screws per Strip.
 - b** Place the Plastic Window Cill (No. 20) onto the 4ft Window Panel (No. 4a) opening. Ensure the cill sits on top of the cladding and flush to the central upright. Secure in place using 3x30mm screws, screwing through the cill into the framing behind.
 - c** Position the Styrene sheets (No. 21) on top of the Plastic Window Cill (No. 20), ensuring they are equally spaced in the window openings.
- For added weather protection, use a sealant application gun to apply a neat line of Clear Silicone round the outside edges of the Styrene.
 **Silicone sealant not provided.
- d** Position the remaining three Window Strips (No. 19) on top of the cill on either side of the Styrene and the centre. Place the Top Window Strip (No. 18) above the previously placed strips, along the top of the window opening.

Secure in place using 3x30mm screws per strip. Ensure to screw through the strips into the framing behind, not the Styrene.

Repeat this process (A-D) to fix the strips, cill, styrene sheets and sealant into both Window Panels.

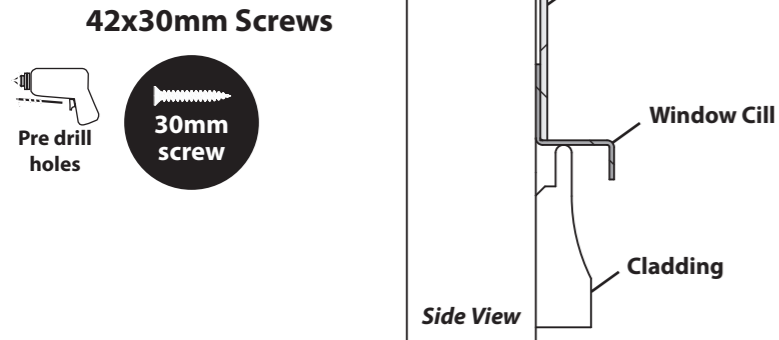

IMPORTANT: Pre-drill before fixing screws.

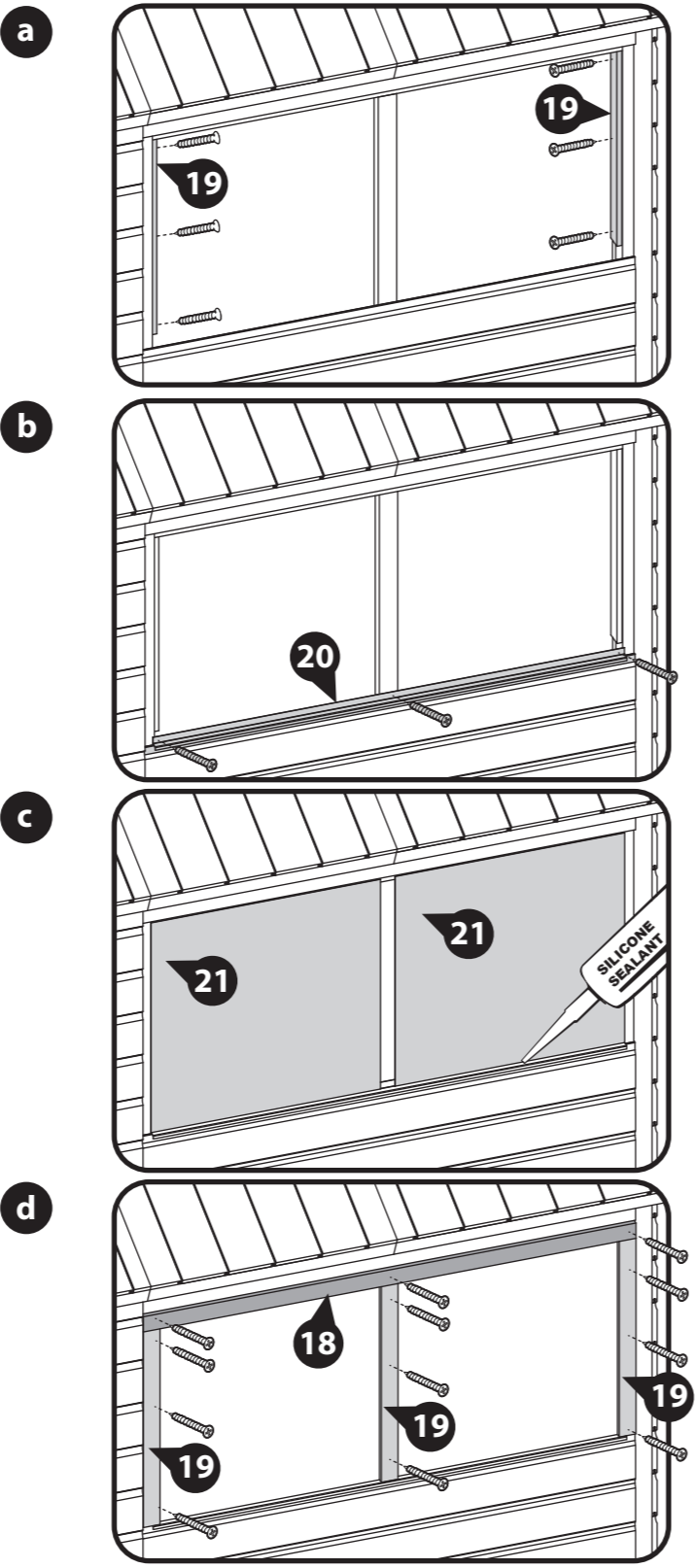

Step 29

- Parts needed - No. 31 QTY 1

- a** Cut the Felt (No. 31) into three sheets measuring: 3200mm (L) x 1000mm (W).
- Lay the sheets onto the roof in the order shown in the diagram, ensuring there is a 50mm overhang around the sides and that each sheet overlaps by 100mm.
- b** Secure the felt in place by hammering felt tacks into the overlapping layers, the front, back and sides of the building at 100mm intervals, as shown.

Ensure to fold the corners of the Felt over each other to create a neat finish, as shown.

150 x Felt Tacks

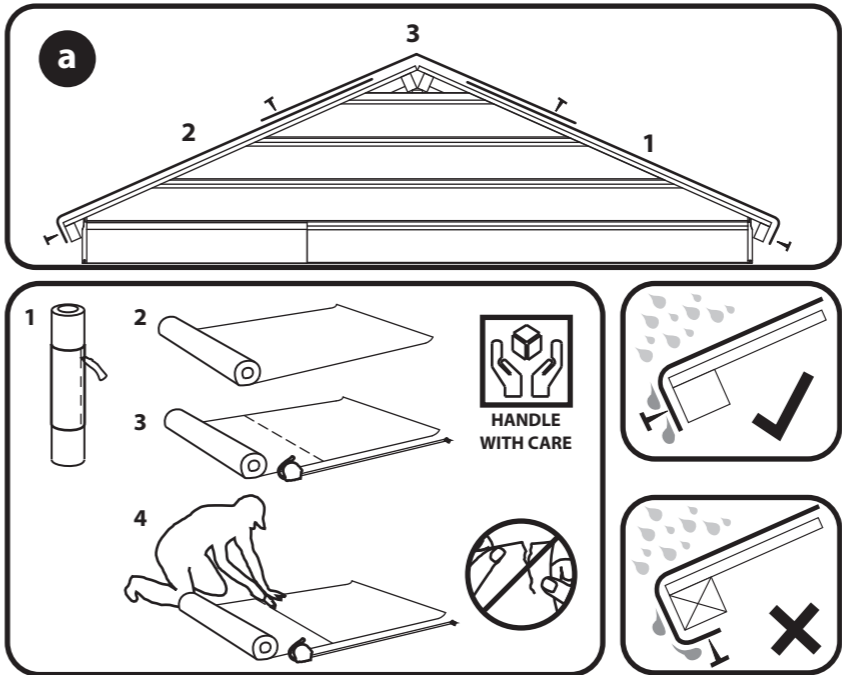
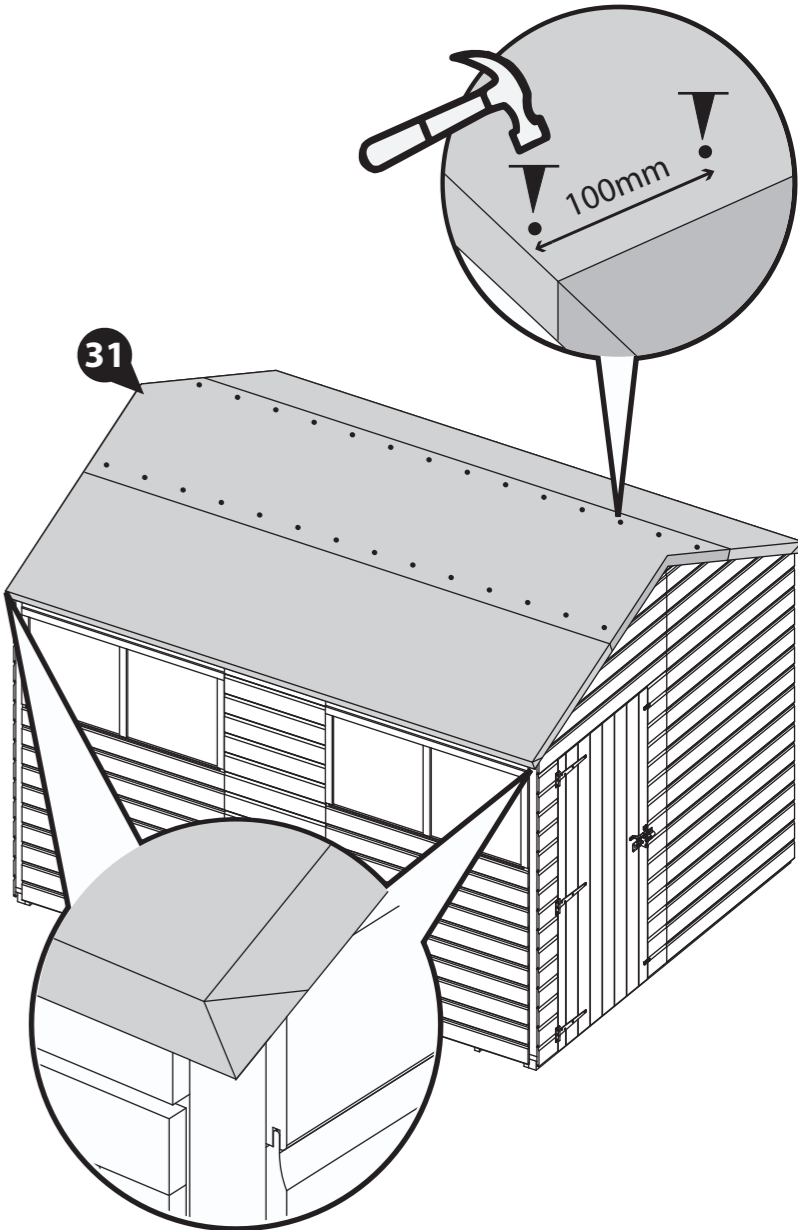

Step 30
Parts needed - No. 22 QTY 12

Please note: You have been supplied with 12 Cover Trims (No. 22) however you may not need to use them all.

- a** At each corner and Panel join, use a tape measure to measure the distance from the bottom of the Panel to the underside of the Roof framing, as shown.

Mark the measurements onto the cover trims and cut to size if required.

- b** Locate the cut down Cover Trims (No. 22), over each Panel join and corner, ensuring they sit centrally over the joins and flush to the Panel cladding at the corners.

Secure the strips in place using 3x30mm screws per strip, alternating fixing into each Panel when over a join.

34x30mm Screws

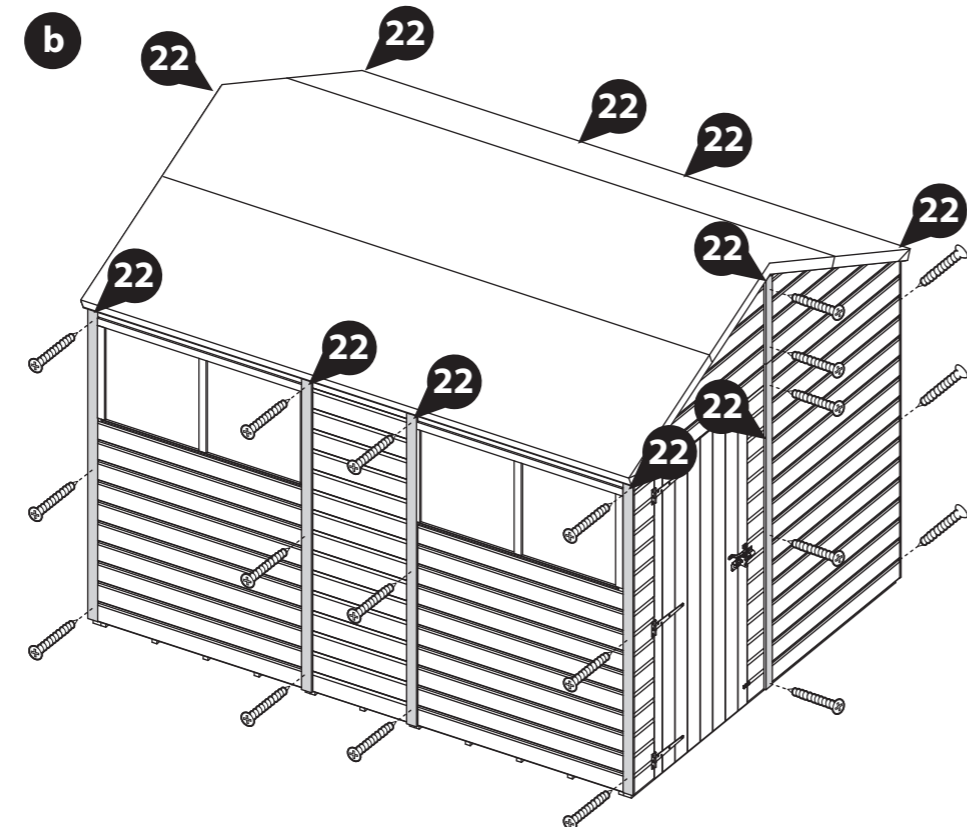
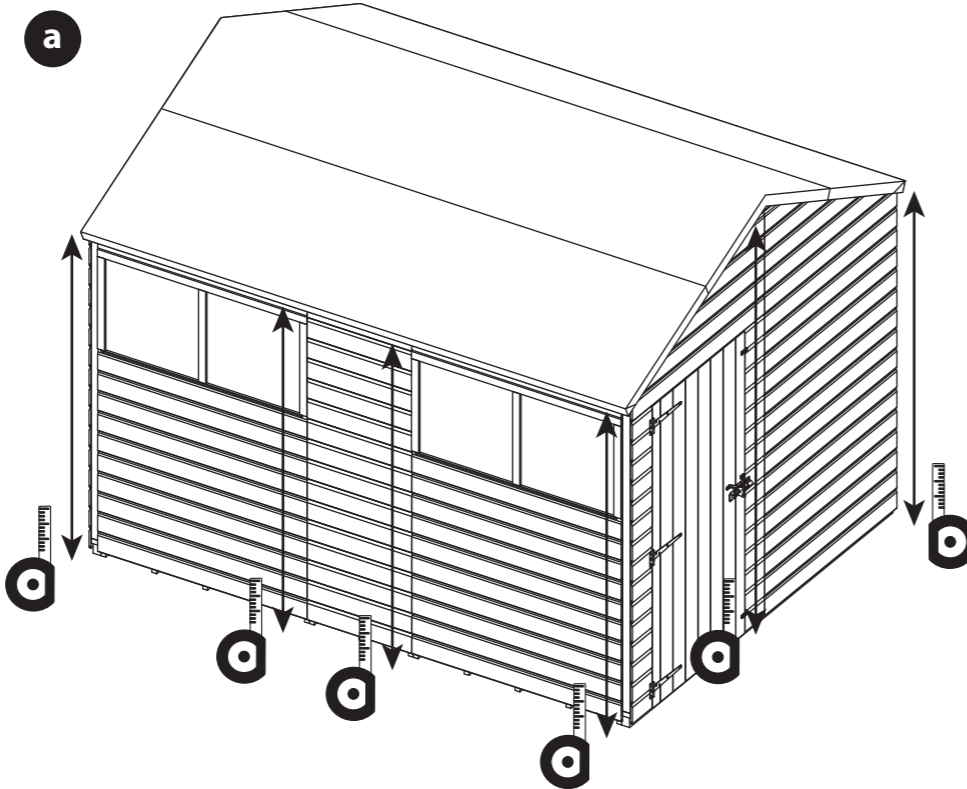
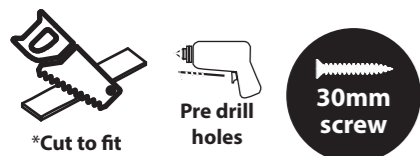

IMPORTANT: Pre-drill before fixing screws.

Step 31
Parts needed - No. 23 QTY 4
No. 24 QTY 2

- a** Locate two Fascias (No. 23), to each end of the building, making sure the angled ends meet at the top of the apex.

- b** The Fascias (No. 23) will overhang past the end of the roofs - mark the overhang onto the Fascias using a pencil or tape.

To get a neat cut, align the pre-cut angled end of one the Fascias with the mark and draw a line. Using a saw, remove the excess material.

- c** Re-position the Fascias, ensuring to trap the Felt between the Roof and Fascia.

Secure the Fascias in place using 3x40mm screws.

Position the Finials (No. 24) on top of the Fascias at either end of the building and secure in place using 2x40mm screws per Finial.

16x40mm Screws



IMPORTANT: Pre-drill before fixing screws.

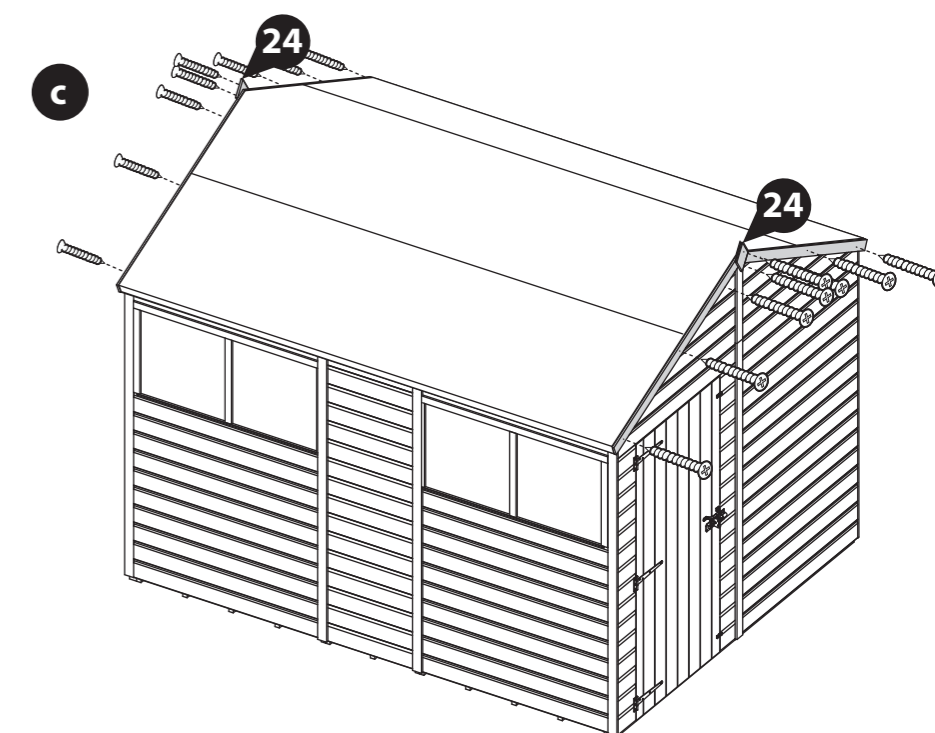
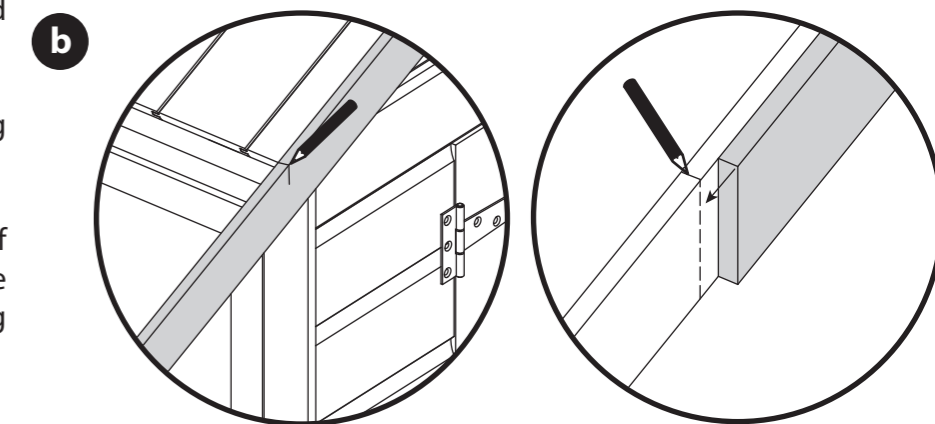
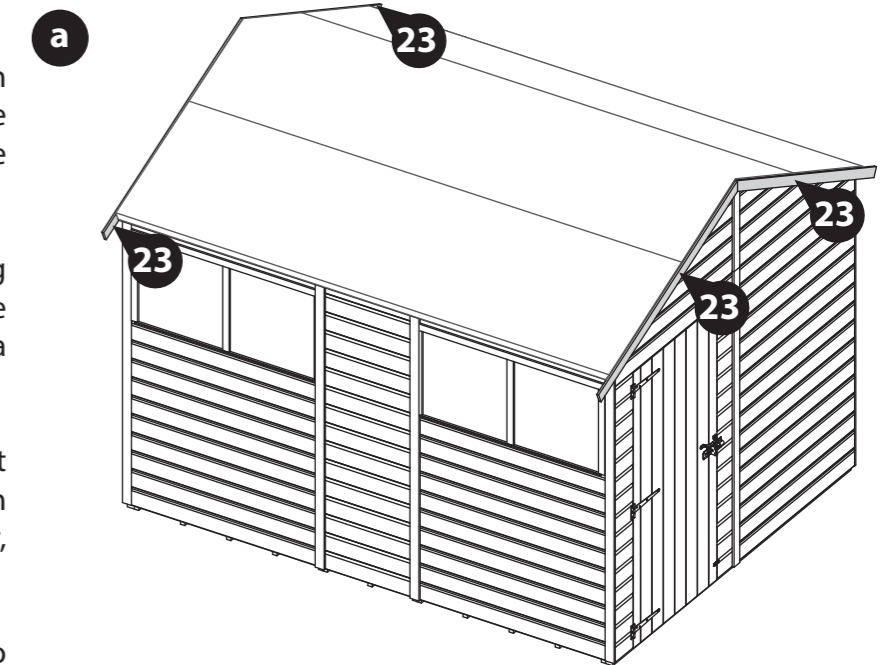

Step 32

Once constructed, apply a preserving treatment and a waterproofing treatment to your garden building as soon as possible. This will help to protect your building and prevent decay.

See page 22 for a full guide and instructions.

Once fully treated, score around the protective covers on the glazing and carefully peel the coverings back.

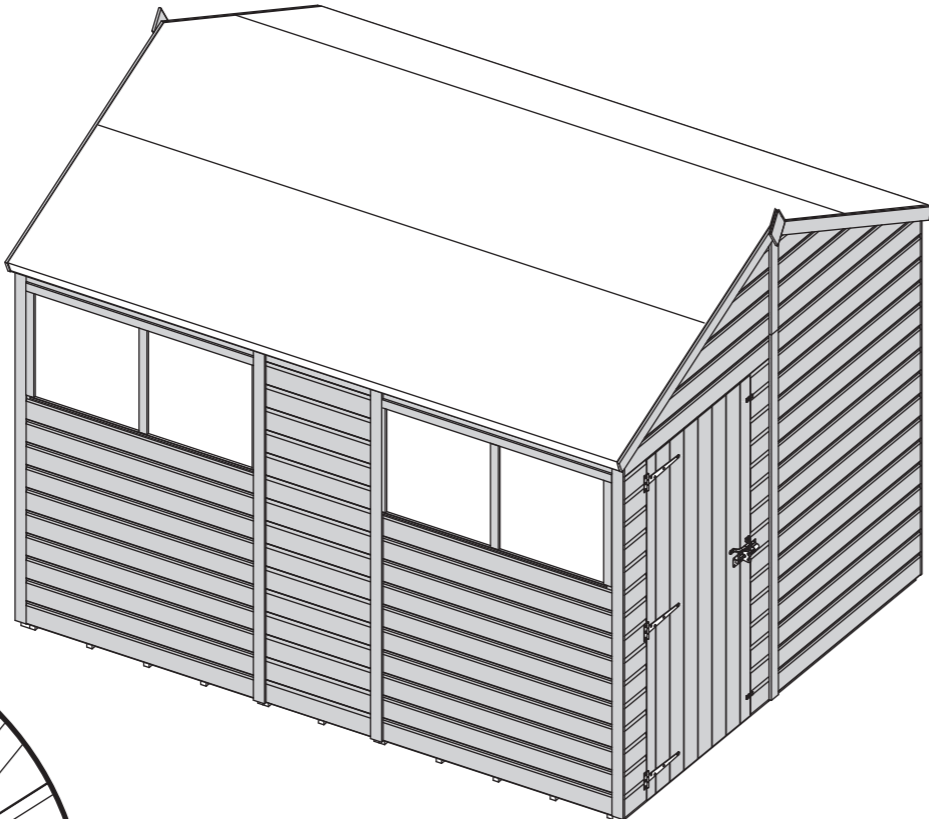

Apply treatment.



Score and peel.

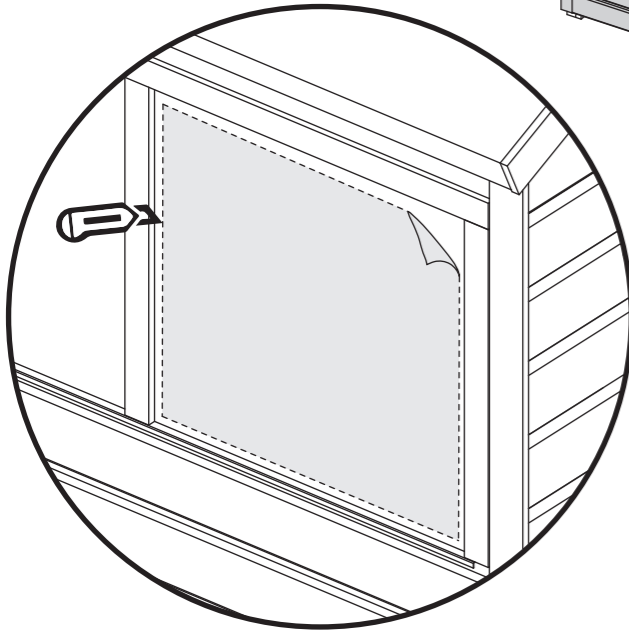

LEAVE US A REVIEW...



Want to share your experience with us?
Leave us a review on Feefo, TrustPilot or Google.

Your reviews help other people find and trust our business, as well as helping to play an important role in our growth and improvement!

TREATING YOUR GARDEN BUILDING

Preservation of wood that's outdoors is vital. A little early care will help protect your garden building, improve its appearance and ensure maximum longevity. Insects, moisture, salt, and changing weather can have dramatic effects on the stability and appearance of your garden building. Once your building is installed, you've checked it over and you're happy with it, you can take a few basic precautions to prepare it for the elements. Treating your garden building helps prevent decay and, by repelling water, discourages the growth of moulds and fungi that could jeopardise the structural integrity of the wood.

Dip Treated buildings - Require a preservative treatment to protect against rot and decay and a waterproof treatment to prevent water ingress

Pressure Treated buildings - Require a waterproof treatment to prevent water ingress

Log Cabins/Insulated Garden Rooms - Are supplied untreated and require a preservative and waterproofing treatment.



ANY QUESTIONS?

Scan the QR code to contact us via our customer portal.

To apply a preservative and water proofing treatment (pressure treated products do not require a preserver), follow the manufacturer's instructions but in principle, stick to the following steps:

- ✓ Weather permitting, ensure to treat your garden building within 14 days of installation.
- ✓ Wear latex or rubber gloves, eye protection and (if spraying) a mask.
- ✓ Prepare the wood, by sanding down any ridges or inconsistencies in the wood, smoothing out knots and end-cuts.
- ✓ Choose a dry day to treat your garden building. If you're spraying rather than brushing paint on, avoid a windy day.
- ✓ Be sure you can safely reach all the sections you need to paint - and if you need a ladder, make sure it's safely positioned before climbing. Lay dust sheets around to avoid paint splatters on your base or surrounding plants.

- ✓ Tape around windowpanes to avoid smears when you're painting the frames.
- ✓ Keep pets and small children out of the way. The last thing you want is to have fur on your garden building paint, or little painted footprints all over your garden and home.
- ✓ Fill any gaps in the building's body with caulk or wood filler to prevent water and draughts getting in. Silicone based caulk is flexible and will move with the timber when temperature and humidity change. Allow to dry completely before treating. A handy tip for finding gaps is to go into your garden building and look for light leaking through joins and frames. If light gets in, then so will water.
- ✓ Liberally apply at least two coats of the treatment products with a brush or spray, taking care to allow the first coat to completely dry before applying the second.
- ✓ Make sure the solution permeates the whole of the surface area, especially around natural cracks, end cuts and nail/screw holes.



APPLY WOOD TREATMENT
IMMEDIATELY
AFTER ASSEMBLY



1 Perimeter

Check around the perimeter of your product to ensure there are not trees or plants that are in contact with or overhanging the building. This can affect airflow and overhanging trees, or branches can damage the roof, it is advised to keep plants at a distance.

2 Repair

Inspect the interior and exterior of the product to look for splits, cracks, and holes. Although this is a natural occurrence it can be prevented. A wood filler can be used to close the splits, cracks, and holes.

3 Roof

Check your roof regularly for tears, splits, damaged wood and fallen debris. If you notice any of this immediate repair is critical.

4 Doors & Windows

Expansion and contraction can cause doors and windows to stick or become difficult to open. Small adjustments to the hinge position can be made to the doors and windows to allow free movement.

5 Oil

Hinges can seize up over time, apply lubricant to the hinges and locks annually.

6 Screws & Bolts

It is advised to check all screws and bolts and tighten any loose you might find. For log cabins specifically the storm braces will require loosening. During humidity and temperature changes (seasons) to allow expansion and contraction to prevent gaping, twisting, popping, and warping.

7 Wash

At least once a year, give the outside of you building a good wash, to remove cobwebs, leaves, or any other dirt that may accumulate on the exterior.

8 Airing

Airing your product regularly prevents the build up of condensation which can cause the timber to warp, bow, boards to pop, distortion, rot and mould. Condensation can build up over time or daily, it is caused by a rise and fall in temperature.

Excessive moisture levels within your building can cause water to collect on the roofs, walls and floors internally. Leaving doors and windows open regularly can help combat the natural moisture build up.

9 Clean & Tidy

It is good practice to clean the inside and outside of your product regularly. Clear out the contents, sweep the floor, remove dirt and cobwebs. Check for areas of damp and investigate the cause to remove and prevent future occurrences. Check the ground around your product for build up of debris such as leaves, remove and ensure there is clear ventilation underneath the floor.

Additional Playhouse Maintenance:

It is recommended that the following checks and maintenance are carried out at the beginning of each season as well as at regular intervals during the usage season.

- Check all nuts /bolts/ screws for tightness and tighten when required.
- Check for movement / opening of wood giving rise to protrusion of nail heads and tips.
- Check hinges.
- Replace defective parts in accordance with the manufacturers instructions.
- Check any crossbeams, suspensions and anchors.
- If a swing is included; check the swing seat, chains and ropes.

IF THESE CHECKS ARE NOT CARRIED OUT THE ACTIVITY TOY COULD BECOME A HAZARD

All our garden buildings have been designed and manufactured with care and attention to be the perfect addition to your outdoor space. To ensure you do get the best out of your new garden building and to increase the longevity we advise that you follow the product instructions and our manufacturer's recommendations as detailed below. Thank you for choosing a Mercia Garden product!

1 Choosing the most suitable location for your garden building...

A minimum of 60cm should be left around the perimeter of your garden building to allow access for maintenance, annual treatment and to allow air flow around the building.

Where possible you should avoid placing your garden building underneath large trees to prevent the tree causing damage to the building.

2 Preparing the base for your garden building...

All our buildings must be built on a firm, level base to ensure the longevity of the building and prevent the wood from distorting. We recommend either concrete, concrete slabs or a wooden base, such as our 'Portabase'.

The base should be slightly smaller than the external measurement of the building, i.e. the cladding should overlap the base, creating a run off for water and preventing water from pooling underneath the building.

We also recommend that the floor of the garden building is a minimum of 25mm above the surrounding ground level to avoid flooding.

3 After installation...

Once your garden building has been installed, it will need to be treated within 14 days (weather permitting) and annually to prevent the timber from deteriorating and to waterproof it. This is required to maintain the anti-rot guarantee.

Dip Treated buildings - Require a preservative treatment to protect against rot and decay

and a waterproof treatment to prevent water ingress.

Pressure Treated buildings - Require a waterproof treatment to prevent water ingress.

Log Cabins/Insulated Garden Rooms - Are supplied untreated and require a preservative and waterproofing treatment.

We also recommend using a silicon sealant on the inside and outside of the windows as soon as possible after assembly and treatment to fully seal the windows.

Roofing felt/covering should be checked annually and replaced or fixed accordingly.

4 General maintenance and wood characteristics

As wood is a natural material it may be affected by the following:

Shrinkage and warping - The timber used in the construction of your garden building will have retained some of its natural moisture content. The moisture content of the timber will vary, depending upon prevailing environmental conditions, which will result in the components either naturally expanding or contracting. As the components dry out, shrinkage may occur. A good waterproofing treatment from the start is the best protection to minimise the effect of moisture loss/intake.

In extended periods of very warm weather getting some moisture to the building will help the overall balance. You can do this by spraying it down lightly with a garden hose. In contrast, after snow fall try to remove the snow as best as possible from the roof to prevent moisture intake and to remove the extra weight.

Top tip - using a garden brush will help you to reach the highest part of the building to remove snow and any debris left from bad weather.

Damp and mould - During the winter months, cold and damp conditions can result in an increased amount of moisture within your garden building, especially when used infrequently. Condensation can form on the timber and other items stored within your garden building. If left this moisture is likely to cause mould and mildew.

To prevent the build-up of moisture, we recommend leaving the door or windows of your building open from time to time, to allow the fresh air to circulate. We also advise against storing wet or damp items in your garden building as this will also increase the level of moisture in the building. If mould or mildew does start to form within your building we recommend using an anti-mould cleaner to remove it and to prevent it spreading, which if left untreated could permanently damage your garden building.

Splits, cracks and knots - You may notice small splits and cracks in some components or holes may appear where knots shrink and fall out. This will not affect the structure of your Garden building however, if you wish to fill them this can be easily done using any good quality wood filler.

Sap - is naturally occurring in wood and may appear in some boards of your garden building. If you wish to remove the sap, we advise waiting until it is dry and then using a sharp knife to carefully remove it. If the removal of the sap causes a hole in the timber, we recommend using a good quality wood filler to fill it.

For more handy hints and tips on how to care and maintain your garden building please refer to the MGP Customer Portal at www.mgplogistics.co.uk



Any further questions?

Contact our Customer Service Team via the MGP Customer Portal at: www.mgplogistics.co.uk

1

Manufacturer's Warranty

All Mercia Garden Products are supplied with a 1 year warranty on all parts against manufacturing defects.

This warranty does not cover movement, warping or splitting of timber products over time.

This warranty will be voided if any of the following occur:

1. The building has been customised or modified/adapted in any way.
2. The person claiming is not the original purchaser of the building.
3. Any damage has been caused by or as a result of misuse.
4. The building has not been maintained and cared for in accordance to our advisories and manufacturer's recommendations.
5. The building has not been treated annually or as per the manufacturer's recommendations, please ensure receipts are kept to validate this claim.
6. The building has not been erected, fitted or installed as per the supplier instructions.
7. The building has not been erected on a suitable sized firm flat, solid level concrete/slab base or placed on pressure treated bearers.
8. The building is or has been placed with 2 feet (600mm) of any obstructions (walls, trees, plants, fences etc.) which can allow moisture to penetrate the timber.
9. The roofing felt has been incorrectly fitted or damaged, allowing water ingress, or has not been properly maintained.
10. Any windows and joints have not been sealed, inside and out, with silicone or other watertight sealant.
11. Any timber has been cut, pierced or drilled without subsequent application of approved cut-end treatment.

REGISTER FOR YOUR
10 YEAR
ANTI-ROT
GUARANTEE TODAY



www.mgplogistics.co.uk

2

Anti-rot Guarantee

Mercia Garden Products offer a 10 year anti-rot guarantee on all dip treated (a preparatory treatment) and 15 years on all pressure treated products. This guarantee covers solid timber against rot, decay, blue stain and insect attacks.

To validate the guarantee, the building must be treated (as detailed within manufacturer's recommendations) within 14 days (weather permitting) of assembly and annually thereafter.

This guarantee does not cover movement, warping or splitting of timber products over time.

This guarantee will be voided if any of the following occur:

1. The building has been customised or modified/adapted in any way.
2. The person claiming is not the original purchaser of the building.
3. Any damage is caused by or as a result of misuse.
4. The building has not been maintained and cared for in accordance to our advisories and manufacturer's recommendations.
5. The building has not been treated annually or as per the manufacturer's recommendations, please ensure receipts are kept to validate this claim.
6. The building has not been erected, fitted or installed as per the supplier instructions.
7. The building has not been erected on a suitable sized firm flat, solid level concrete/slab base or placed on pressure treated bearers.
8. The building is or has been placed with 600mm of any obstructions (walls, trees, plants, fences etc.) which can allow moisture to penetrate the timber.
9. The roofing felt has been incorrectly fitted or damaged allowing water ingress, or has not been properly maintained.
10. Any windows and joints have not been sealed, inside and out, with silicone or other watertight sealant.
11. Any timber has been cut, pierced or drilled without subsequent application of approved cut-end treatment.